

# REDMOND

## Smart Control Center SkyCenter RSC-12S-A User Manual

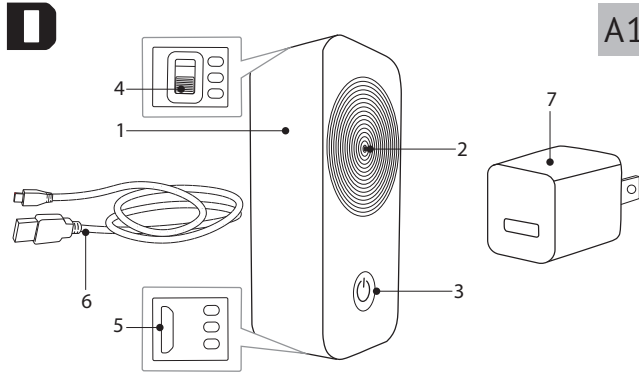

⚠ Carefully read all instructions before operating the appliance and save them for future reference. By carefully following these instructions you can considerably prolong the service life of your appliance.

The safety measures and instructions contained in this manual do not cover all possible situations that may arise during the operation of the appliance. When operating the device the user should be guided by common sense, be cautious and attentive.

## IMPORTANT SAFEGUARDS

- The manufacturer is not responsible for injuries caused by failure to comply with the safety requirements and operation rules of the appliance.
- This appliance is intended to be used for nonindustrial use in household and similar spheres of application: staff kitchen areas in shops, offices and other working environments, farm houses, by clients in hotels, motels and other residential environments. Industrial application or any other misuse will be regarded as violation of proper service conditions. Should this happen, manufacturer is not responsible for possible consequences.
- Before plugging in the appliance ensure that the circuit voltage matches operating voltage of the appliance (see technical specifications or manufacturer's plate on the appliance).
- This equipment should be installed and operated with a minimum distance of 20 centimeters between the radiator and your body.
- Unplug the device during a thunderstorm, if it's not used for a long time or when cleaned.
- Due to the fact the product produces some slight heat during the operation, it isn't allowable to put it onto some furniture or radiators, and to be covered by any blind, table cloth or any other objects.
- Do not use the appliance outdoors as ingress of moisture or foreign objects inside the housing can result in damage.
- Before cleaning the appliance ensure that it is unplugged. Clean the body with a soft cloth.

**STOP** DO NOT immerse the housing in water!

- This equipment has been tested and found to comply with the limits for a Class B digital device, pursuant to part 15 of the FCC Rules. These limits are designed to provide reasonable protection against harmful interference in a residential installation. This equipment generates, uses, and can radiate radio frequency energy and, if not installed and used in accordance with the instructions, may cause harmful interference to radio communications. However, there is no guarantee that interference will not occur in a particular installation. If this equipment does cause harmful interference to radio or television reception, which can be determined by turning the

equipment off and on, the user is encouraged to try to correct the interference by one or more of the following measures:

- Reorient or relocate the receiving antenna.
- Increase the separation between the equipment and receiver.
- Connect the equipment into an outlet on a circuit different from that to which the receiver is connected.
- Consult the dealer or an experienced radio/TV technician for help.
- This appliance can be used by children aged from 8 years and above and persons with reduced physical, sensory or mental capabilities or lack of experience and knowledge if they have been given supervision or instruction concerning use of the appliance in a safe way and understand the hazards involved. Children shall not play with the appliance. Keep the appliance out of reach of children aged less than 8 years. Cleaning and user maintenance shall not be made by children without supervision.
- Keep the packaging (film, foam plastic and other) out of reach of children as they may choke on them.
- Shielded cables must be used with this unit to ensure compliance with the Class B FCC limits.
- No modifications or adjustments to the product are allowed. All service and repair works should be carried out by an authorized service centre. Failure to do so may result in device and property damage or injury.

**STOP** Changes or modifications not expressly approved by the party responsible for compliance could void the user's authority to operate the equipment.

**CAUTION!** Do not use the appliance in case of any malfunctions.

### Technical Specifications

Model.....	SkyCenter RSC-12S-A
Voltage.....	5 V
Power.....	1.6 W
Interface.....	USB
Body material.....	heat-resistant plastic
Indication.....	LED
Type of control.....	electronic, remote (Ready for Sky)
Data transmission standard.....	Bluetooth v4.0, Wi-Fi
Supported operating systems.....	iOS, Android
Overall dimensions.....	90 × 40 × 30 mm
Net weight.....	55 g ± 3%
USB cable length.....	1 m

### Package Includes

Smart control center.....	1 pc.
USB cable.....	1 pc.
AC adapter.....	1 pc.
User manual.....	1 pc.

The manufacturer reserves the right to make any modifications to design, packaging, or technical specifications of the product without prior notice.

### Parts of the appliance A1

- |                   |                        |
|-------------------|------------------------|
| 1. Housing        | 5. Micro USB connector |
| 2. Indicator      | 6. USB cable           |
| 3. Control button | 7. AC adapter          |
| 4. Switch         |                        |



## I. PRIOR TO FIRST USE

Carefully remove the appliance from the packaging. Dispose of all packaging materials.

-  Keep all warning labels, including the serial number identification label located on the housing. After transportation or storage at low temperatures allow the appliance to stay at room temperature for at least 2 hours before using. Before operating, make sure that the device has no dents, cracks or any other visible damages.

## II. OPERATION

The smart control center allows you to control household appliances from around the world via the Internet: it will become a bridge between Ready for Sky devices at home and your mobile device.

- Download the software from the App Store or Google Play (depending on your operating system) onto your smartphone or tablet.
-  For the minimum supported OS version, see the company's official website [www.redmond.company](http://www.redmond.company) or the application description at the App Store and Google Play.
- Start the Ready for Sky app, create an account, and follow the prompts appearing on the screen.
- Connect the device to the power network using the USB cable.
- Set the switch to the "I" position: the indicator on the device will blink.
- Select the connected device from the list of available appliances in the application.
- Press and hold down the control button on the device (for about 5 seconds): the indicator will start flashing.
- Release the button: the synchronization will start, the indicator will start flashing. At the end of synchronization the indicator will stop flashing and the device will switch to the standby mode.
-  If the connection isn't made within 60 seconds, the appliance will switch to the standby mode. After successful connection is made, follow the prompts on the application screen to complete the setup. To remotely control your devices on the base of the Ready for Sky technology connect them to the smart control centre according to their user manuals.
-  In order to maintain a stable connection the smart control center remote controller must be placed no more than 15 meters away from the appliances connected to it. You can connect several mobile devices to the smart control centre, that means several users can control one and the same device. In this case the device will perform the last received command.
- To turn the device off, set the switch to the "0" position, unplug the device.
- To disable the remote control feature and delete data on previously connected devices in the standby mode press and hold down the control button for about 10 seconds till the indicator on the device will blink. Release the button, the device will switch to the standby mode.

## III. CLEANING AND MAINTENANCE

Before you start cleaning the appliance, make sure that it is unplugged. Use soft damp cloth or sponge to clean the housing.

-  **DO NOT immerse the housing in water or wash it under running water! Prevent moisture from getting on contact pins or inside the housing. DO NOT use a sponge or tissue with hard or abrasive surface or abrasive pastes. DO NOT use any chemically aggressive substances.**

### Storage and transportation

Store the assembled appliance in a dry, ventilated place away from heating appliances and direct sunlight.

During transportation and storage, do not expose the device to mechanical stress, that may lead to damage of the device and/or violation of the package integrity.

Keep the device package away from water and other liquids.

## IV. BEFORE CONTACTING SERVICE CENTER

-  In case you didn't manage to eliminate the defects, please, refer to the authorized service center.

Problem	Possible cause	Solution
Appliance does not switch on	Voltage supply failure	Check the voltage supply
	The switch is in the "0" position	Set the switch on the housing to the "I" position
Synchronization attempt failed	Bluetooth function on the mobile device is disabled	Enable Bluetooth function on the mobile device
	Ready for Sky app on the mobile device is deactivated	Run the Ready for Sky app on the mobile device
	Sync devices are too far	Ensure devices are located within 15 metres from each other

-  **NOTE!** In case any failure occur in the operation of the Ready for Sky app, it is not obligatory to apply to the service centre. Apply to redmond

technical support service and obtain the consultation of our specialists on error elimination and/or failure in Ready for Sky operation. Your comments and suggestions concerning application operation will be taken into account upon successive update. Contact data of user support service of redmond appliances can be found in your country on the website [www.redmond.company](http://www.redmond.company). You may also obtain the help, filling the contact form provided on the website.

## V. PRODUCT WARRANTY

We warrant this product to be free from defects for a period of 12 months from the date of purchase. If the appliance fails to operate properly within the warranty period and is found to be defective in material or workmanship, we will repair or replace it free of charge. This warranty comes into force only in case an original warranty service coupon with a serial article number and an accurate impress of the company of the seller proves the purchase date. This limited warranty does not cover damage caused by the failure to use this product for its normal purpose or in accordance with the instructions on the proper use and maintenance of the product, or any kind of repair works. Do not try to disassemble the appliance and keep all package contents. This warranty does not cover normal wear of the appliance and its parts (filters, bulbs, non-stick coating, gaskets, etc.).

The service life and the applicable product warranty period start on the date of purchase or the date of manufacture (if the purchase date cannot be established).

You can determine the manufacture date by the serial number, located on the identification label on the housing of the appliance. The serial number consists of 13 digits. 6th and 7th digits of the serial number identify the month, 8th digit the year of manufacture.

The service life of the product, established by the manufacturer is 3 years from the date of purchase, provided that the unit is used and maintained in accordance with the user manual and applicable technical standards.

### Environmentally friendly disposal (WEEE)



The packaging, user manual and the device itself shall be taken to the applicable collection point for the recycling of electrical and electronic equipment. Do not throw away the electronic waste to help protect the environment.

Old appliances must not be disposed with other household waste but must be collected separately. Municipal disposal of recyclable wastes is free of charge. The owners of old appliances are required to bring it to a waste facility centre. With this little extra effort, you can help to ensure that valuable raw materials are recycled and pollutants are treated as appropriate.

This appliance is labelled in accordance with European Directive 2012/19/EU – concerning used electrical and electronic appliances (waste electrical and electronic equipment WEEE).

The guideline determines the framework for the return and recycling of used appliances as applicable throughout the EU.

## VI. PRODUCT WARRANTY

We warrant this product to be free from defects for a period of 12 months.

If the product fails to operate properly within the warranty period and is found to be defective in material or workmanship, we shall either repair or exchange individual parts or the entire product.

During the sale make sure that the seller properly filled the warranty card, indicated the device's serial number, date of sale, applied the stamp, as well as put his signature.

Check the device for completeness, technical condition, review the terms of warranty and put your signature.

It is not allowed to alter, erase or copy the data indicated in the warranty card.

### The warranty will be only VALID if:

- Consumer submits proof of purchase in the form of user manual, service booklet (or any other documents that may prove the purchase, according to local law), and serial number identification label on the product.
- Service booklet is provided with corresponding model number and serial number of the product, date of purchase, seller's stamp and signature.
- Product was used in accordance with the user manual and applicable technical standards.
- Product was not disassembled, modified, or repaired in any way by any persons, unauthorized to do so by REDMOND; product was not damaged due to improper operation or maintenance.

### This warranty is void if the warranty service coupon has been altered, or defaced in any way.

### The present warranty is NOT ENFORCEABLE if:

- The product was used other than as intended and described in the product instruction manual.
- Damages or defects to the product were caused by improper use, such as:
  - improper installation or connection (including connection to a power source with voltage supply different from the one specified in the user manual and rating plate on the product, or a power source that does not comply with your country's electrical safety standards);
  - mechanical or thermal damages caused by misuse (including negligence, improper storage, or transportation) or any accident or injury caused by failure to comply with safety standards;
  - damages or modifications to power cord;
  - exposure of product parts which are not heat-proof to excessive heat or cold;

- damages caused by foreign liquids or bodies, such as insects, rodents, etc.;
  - untimely replacement or maintenance of any of the consumable parts and accessories, requiring periodical cleaning/replacement;
  - any repairs, modifications, or opening of the product carried out by unauthorised personnel, resulting in construction, functional, or software change;
  - the product was repaired with unauthorised spare parts, connected to, or used with an accessory of improper quality, non-standard characteristics, or not intended for use with the product;
  - all other defects arising from failure to follow instructions relating to the product's use.
3. Damages caused by careless or deliberate actions taken by third party.
  4. Damages caused by disasters such as fire, flood, lightning, etc.
  5. Product's serial number has been removed, erased, defaced, altered, or made illegible in any way.

This warranty does not cover normal wear and tear of components, mechanisms, and accessories (eg. metal multicooker bowls, non-stick coated bread pans, juicer foam separators, blades, vacuum brushes, gaskets, LED bulbs), consumable parts (dust collectors, removable cartridges and filters, shampoos, and other liquids), replaceable batteries, and accumulators.

The warranty pledge does not apply to periodic maintenance and servicing, if such is required by the user manual. **If you require warranty service, please contact the Help Desk or nearest authorised service centre (refer to the user manual for the list of authorised service centres available).**

The list of the authorised service centres in your area can also be obtained at [www.redmond.company/services](http://www.redmond.company/services).

**FCC ID Label:**

**FCC ID: 2AMGX-RSC12SA**

**This device complies with Part 15 of the FCC Rules. Operation is subject to the following two conditions: (1) this device may not cause harmful interference, and (2) this device must accept any interference received, including interference that may cause undesired operation.**