

REVISION HISTORY			
REV	DESCRIPTION	DATE	APPROVED
A	INITIAL RELEASE		

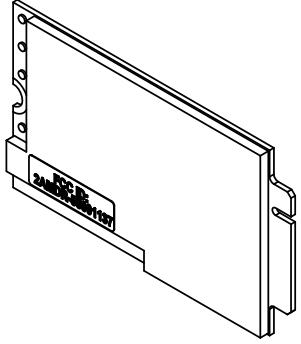

ITEM NO.	QTY.	PART NUMBER	DESCRIPTION	VENDOR PART NUMBER	VENDOR
2	1	950-00278	LABEL, FCC MODEM		
1	1	550-01137	5G MODULE, RM500Q-GL	RM502QAEAP-M20-SGASA	QUECTEL

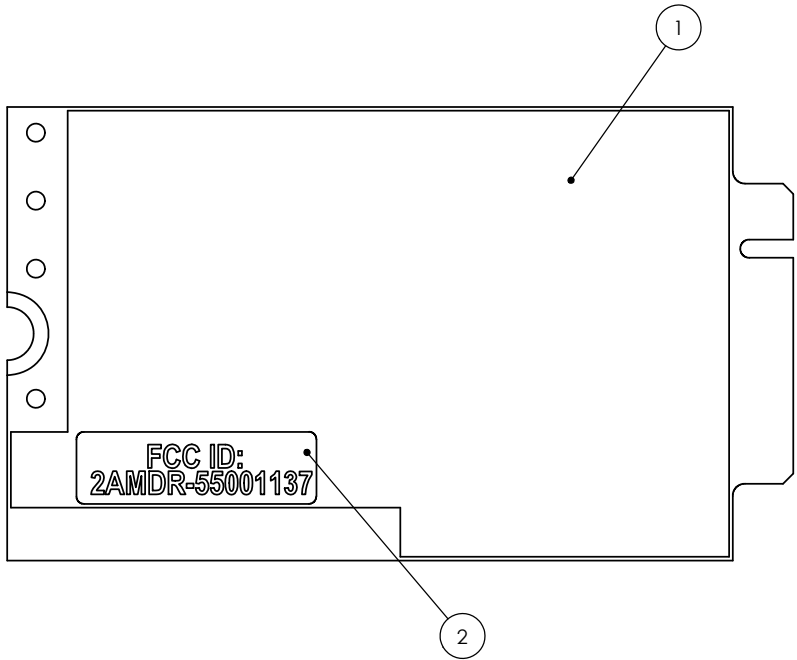

4501 HATFIELD STREET
PITTSBURGH, PA 15201

CARNEGIEROBOTICS.COM
CAGE CODE: 4QND3

THE INFORMATION CONTAINED IN THIS DRAWING IS THE SOLE PROPERTY OF CARNEGIE ROBOTICS LLC. ANY REPRODUCTION IN PART OR AS A WHOLE WITHOUT THE WRITTEN PERMISSION OF CARNEGIE ROBOTICS LLC IS PROHIBITED.

	ENGR	DATE
DRAWN	AJG	2024-01-18
CHECKED		
ENGR	AJG	2024-01-18
APPROVED		

UNLESS OTHERWISE SPECIFIED DIMENSIONS ARE IN MILLIMETERS
 TOLERANCES: ANGULAR ± 0.5° SURFACE FINISH: 1.6/√R
 X ± 1.3
 X.X ± 0.5
 X.XX ± 0.13

ASSEMBLY, MODEM FCC LABEL

SIZE A	PART NUMBER 830-01711	REV A
MATERIAL N/A	FINISH SEE NOTE	DO NOT SCALE SHEET 1 OF 1

NOTE(S):

1. REFERENCE WORK INSTRUCTIONS FOR ASSEMBLY PROCEDURE.