

RC-300-PTE-16-105112-4-A

**E.M.C Test Report**

**According to the standard:**  
FCC 47 CFR PART 15 : 2015 (§15.247)

**Equipment under test:**  
NEPTULINK  
PAR0017FR  
FCC ID: 2AMCC1202191

**Company:**  
MVG INDUSTRIES

FCC accredited: FR0004

DISTRIBUTION: Mr. CARRO

(Company: MVG Industries)

Number of pages: 53 with 4 annexes

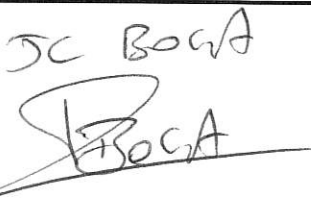
Ed.	Date	Modified page(s)	Written by		Technical Verification and Quality Approval	
			Name	Visa	Name	Visa
0	19/12/17	Creation	B. PELLERIN		SC BOGA	
						

*Duplication of this report is only permitted for an integral photographic facsimile. It includes the number of pages referenced above. This document is the result of testing a specimen or a sample of the product submitted. It does not imply an assessment of the conformity of the whole production of the item tested.*



**TEST CERTIFICATION FOR:** FCC Certification

**NAME OF THE EQUIPMENT UNDER TEST:** NEPTULINK – PAR0017FR

**Serial number:** NK2E-001-1217

**Reference / model (P/N):** -

**Software version:** V 2.1.0

**NAME OF THE MANUFACTURER:** MVG INDUSTRIES

**ADDRESS OF THE APPLICANT:**

**Company:** MVG INDUSTRIES

**Address:** 225 Rue Pierre Rivoalon  
29200 BREST  
FRANCE

**Responsible:** Mr. CARRO

**Person present during the tests:** -

**DATES OF TESTS:** 30 and 31/08/2017  
24 and 27/11/2017

**TESTS LOCATION:** EMITECH laboratory in Montigny Le Bretonneux (78)  
FRANCE.

**TESTS OPERATOR:** A. BERNARD

**TESTS TUTOR:** B. PELLERIN

## TABLE OF CONTENTS

1. INTRODUCTION	4
2. REFERENCE DOCUMENTS	4
3. PRODUCT DESCRIPTION	5
4. TESTS AND CONCLUSION	7
5. DIGITAL MODULATION SYSTEMS	9
6. TRANSMITTER OUTPUT POWER	11
7. PEAK POWER SPECTRAL DENSITY	13
8. ADDITIONAL PROVISIONS TO THE GENERAL RADIATED EMISSIONS LIMITATION	21
9. UNINTENTIONAL RADIATED EMISSIONS AND TRANSMITTER UNWANTED EMISSION IN THE BAND 9 kHz – 25 GHz	23

ANNEX 1: EXTERNAL PHOTOGRAPHIES

ANNEX 2: TEST SETUP PHOTOGRAPHIES

ANNEX 3: 6 dB BANDWIDTH, 20 dB BANDWIDTH

ANNEX 4: BAND EDGE

**1. INTRODUCTION**

This document presents the results of Electromagnetic Compatibility tests performed on the equipment « NEPTULINK – PAR0017FR » according to reference documents listed below.

**2. REFERENCE DOCUMENTS*****FCC 47 CFR Part 15: 2015***

Code of Federal Regulations. Title 47- Telecommunication  
Chapter 1- Federal Communication Commission  
Part 15- Radio frequency devices

***ANSI C63.4: 2014***

Methods of Measurement of Radio-Noise Emissions from Low Voltage Electrical and Electronics Equipment in the range of 9 kHz to 40 GHz.

***KDB 558074 D01 DTS Meas Guidance V04***

Guidance for performing compliance measurement on Digital Transmission Systems (DTS) operating under § 15.247

***ANSI C63.10:2013***

American national Standard of Procedures for Compliance Testing of Unlicensed Wireless Devices

**3. PRODUCT DESCRIPTION**

Class:	B
Antenna type and gain:	Integral antenna: Not communicated
Operating frequency range:	from 2412 MHz to 2462 MHz
Number of channels:	11
Channel spacing:	5 MHz
Modulation:	-
Power source:	24 Vdc (battery)
Software power setting:	V 2.1.0

Modification of the equipment during the tests: YES.

12 ferrites are installed on Ethernet cable and 12 ferrites on power supply cable in accordance with the customer installation. Ferrites are not provided with equipment. See reference in user manual.

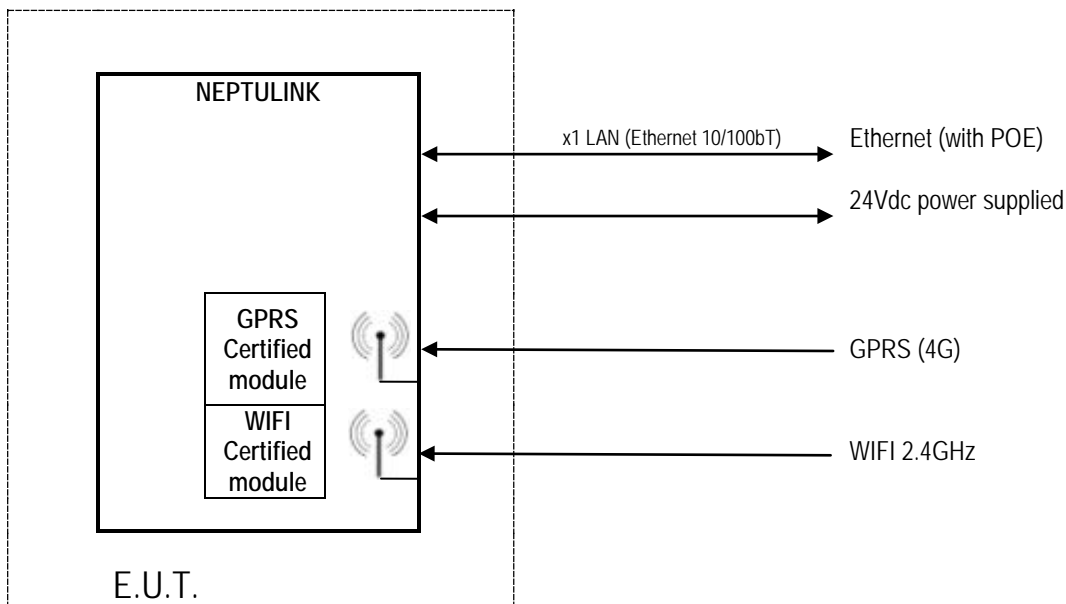

**Radio module and antenna references:**

- WIFI module : WPJ531 from COMPEX SYSTEMS
- GPRS module : Module AirPrime MC7455
- 2.4GHz antennas: Gain: 3.6dBi  
Type : Dipole – MVG INDUSTRIES BRETAGNE MANufacturer

E.U.T.



**4. TESTS AND CONCLUSION**

The following table summarizes test results of the EUT.

Subpart B of the standard FCC part 15 – Unintentional radiators

Test procedure	Designation of test	Test results				Comments
		Pass	Fail	N.A.	N.P.	
15.107	Measurement of conducted emission on AC mains ports	X				
15.109	Radiated emission limits	X				

Subpart C of the standard FCC part 15 – Intentional radiators

Test procedure	Designation of test	Test results				Comments
		Pass	Fail	N.A.	N.P.	
15.205	Restricted bands of operation	X				
15.207	Measurement of conducted emission on AC mains ports	X				
15.209	Radiated emission limits; general requirements	X				
15.215	Additional provisions to the general radiated emission limitations					
	(a) Alternative to general radiated emission limits	X				
	(b) Unwanted emissions outside of § 15.247 frequency bands	X				
	(c) 20 dB bandwidth and band-edge compliance	X				
15.247	Intentional radiated emissions					
	a) frequency hopping and digitally modulated					
	a) (1) hopping mode			X		
	a) (1) (i) frequency hopping in the band 902-928 MHz			X		
	a) (1) (ii) frequency hopping in the band 5725-5850 MHz			X		
	a) (1) (iii) frequency hopping in the band 2400-2483.5 MHz			X		
	a) (2) systems using digital modulation in the bands 902-928 MHz, 2400-2483.5 MHz, and 5725-5850 MHz (6 dB bandwidth)	X				
	b) maximum peak conducted					
	b) (1) frequency hopping in the bands 2400-2483.5 MHz or 5725-5850 MHz			X		
	b) (2) frequency hopping in the band 902-928 MHz			X		

Test procedure	Designation of test	Test results				Comments
		Pass	Fail	N.A.	N.P.	
	b) (3) systems using digital modulation in the bands 902–928 MHz, 2400–2483.5 MHz, and 5725–5850 MHz	X				
	b) (4) maximum peak conducted > 6 dBi					
	b) (4) (i) frequency hopping in the band 2400–2483.5 MHz			X		
	b) (4) (ii) frequency hopping in the band 5725–5850 MHz			X		
	b) (4) (iii) fixed, point-to-point			X		
	c) directional antenna > 6 dBi					
	c) (1) fixed, point-to-point operation			X		
	c) (1) (i) in the band 2400–2483.5 MHz			X		
	c) (1) (ii) in the band 5725–5850 MHz			X		
	c) (1) (iii) fixed, point-to-point			X		
	c) (2) multiple directional beams in the band 2400–2483.5 MHz			X		
	c) (2) (i) information			X		
	c) (2) (ii) sum of the power supplied to all antennas			X		
	c) (2) (iii) one antenna for multiple directional beams			X		
	c) (2) (iv) single directional beam			X		
	d) intentional radiator	X				
	e) peak power spectral density	X				
	f) hybrid system			X		
	g) continuous data stream during the test			X		
	h) to avoid hopping on occupied channels			X		
	i) RF exposure compliance			X		P < 500 mW

N.A.: Not Applicable

N.P.: Not Performed

### Conclusion:

The tested sample « NEPTULINK – PAR0017FR » submitted to the tests complies with the requirements of the standard:

- FCC 47 CFR PART 15 : 2015

According to the limits specified in this report.



<b>5. DIGITAL MODULATION SYSTEMS</b>
--------------------------------------

**Standard:** FCC 47 CFR PART 15 : 2015

**Section:** §15.247 a) (2)

**Test configuration:**

The system is tested in normalized test site.

The test unit is placed on a rotating table, 0.8 m from a ground plane. Zero degree azimuth corresponds to the front of the equipment under test.

The level was maximised in antenna height, azimuth and polarization. The maximum level measured on the spectrum analyser was recorded.

**Distance of antenna:** 3 meters

**Instrumentation test list:**

CATEGORY	BRAND	TYPE	N° EMITECH	Last validity date	Next validity date
Amplifier	Agilent	8449B	14487	11/05/2017	11/07/2018
Antenna	Emco	3115	0941	28/10/2015	28/12/2018
Antenna mast	Maturo	MCU	8410	---	---
Antenna mast	Maturo	AM 4.0	8411	---	---
Cable	C&C	N-10m	11136	01/04/2016	01/06/2018
Cable	C&C	N-8m	11174	18/04/2016	18/06/2018
Cable	C&C	N-2m	11178	16/04/2016	16/06/2018
Cable	C&C	N-2m	11182	20/04/2016	20/06/2018
Filter	BL Microwave	BP2442-84-7CS	5624	10/05/2017	10/07/2019
Receiver	Rohde & Schwarz	FSU8	9129	04/08/2016	04/10/2018
Shielded enclosure	SIDT	SIDT	0549	---	---

**Equipment under test operating condition:**

EUT is in continuous transmission mode.

**Measure conditions:**

Ambient temperature (°C): 21

Relative humidity (%): 39

Resolution bandwidth: 100 kHz

**Results:**

Power source: 24 Vdc

6 dB bandwidth

Mode	Frequency	Results	Comments
b	2412 MHz	8.2 MHz	See annex n°3
	2442 MHz	7.5 MHz	
	2462 MHz	8.8 MHz	
g	2412 MHz	15.1 MHz	
	2442 MHz	15.5 MHz	
	2462 MHz	15.8 MHz	
n20	2412 MHz	15.6 MHz	
	2442 MHz	15.0 MHz	
	2462 MHz	14.8 MHz	
n40	2422 MHz	36.5 MHz	
	2437 MHz	35.1 MHz	
	2452 MHz	35.5 MHz	

20 dB bandwidth

Mode	Frequency	Results	Comments
b	2412 MHz	16.9 MHz	See annex n°3
	2442 MHz	14.8 MHz	
	2462 MHz	15.3 MHz	
g	2412 MHz	16.8 MHz	
	2442 MHz	16.8 MHz	
	2462 MHz	16.9 MHz	
n20	2412 MHz	18.0 MHz	
	2442 MHz	19.8 MHz	
	2462 MHz	19.2 MHz	
n40	2422 MHz	41.6 MHz	
	2437 MHz	43.6 MHz	
	2452 MHz	38.5 MHz	

**Test conclusion:** Complies with the requirements of the standard.

## 6. TRANSMITTER OUTPUT POWER

**Standard:** FCC 47 CFR PART 15 : 2015

**Section:** §15.247 b) (3)

### Test configuration:

The system is tested in normalized test site.

The test unit is placed on a rotating table, 0.8 m from a ground plane. Zero degree azimuth corresponds to the front of the equipment under test.

The level was maximised in antenna height, azimuth and polarization. The maximum level measured on the spectrum analyser was recorded.

**Distance of antenna:** 3 meters

### Instrumentation test list:

CATEGORY	BRAND	TYPE	N° EMITECH	Last validity date	Next validity date
Amplifier	Agilent	8449B	14487	11/05/2017	11/07/2018
Antenna	Emco	3115	0941	28/10/2015	28/12/2018
Antenna mast	Maturo	MCU	8410	---	---
Antenna mast	Maturo	AM 4.0	8411	---	---
Cable	C&C	N-10m	11136	01/04/2016	01/06/2018
Cable	C&C	N-8m	11174	18/04/2016	18/06/2018
Cable	C&C	N-2m	11178	16/04/2016	16/06/2018
Cable	C&C	N-2m	11182	20/04/2016	20/06/2018
Filter	BL Microwave	BP2442-84-7CS	5624	10/05/2017	10/07/2019
Receiver	Rohde & Schwarz	FSU8	9129	04/08/2016	04/10/2018
Shielded enclosure	SIDT	SIDT	0549	---	---

### Equipment under test operating condition:

EUT is in continuous transmission mode.

### Measure conditions:

Ambient temperature (°C): 21

Relative humidity (%): 39

Resolution bandwidth: 1 MHz

**Results:**

Power source: 24 Vdc

Mode	Frequency	Electro-magnetic field (dB $\mu$ V/m)	TP* (dBm)	Limit (dBm)
b	2412 MHz	105.0	+ 7.6	+ 30
	2442 MHz	100.1	+ 2.8	
	2462 MHz	104.0	+ 6.4	
g	2412 MHz	106.3	+ 8.8	
	2442 MHz	106.9	+ 9.5	
	2462 MHz	103.8	+ 6.4	
n20	2412 MHz	106.3	+ 8.8	
	2442 MHz	102.8	+ 5.5	
	2462 MHz	105.3	+ 7.9	
n40	2422 MHz	103.5	+ 6.1	
	2437 MHz	105.6	+ 8.2	
	2452 MHz	103.5	+ 6.1	

\* TP =  $(E \times d)^2 / (30 \times 1.64)$  for d = 3 m

**Test conclusion:** Complies with the requirements of the standard.

**7. PEAK POWER SPECTRAL DENSITY**

**Standard:** FCC 47 CFR PART 15 : 2015

**Section:** §15.247 e)

**Test configuration:**

The system is tested in normalized test site.

The test unit is placed on a rotating table, 0.8 m from a ground plane. Zero degree azimuth corresponds to the front of the equipment under test.

The level was maximised in antenna height, azimuth and polarization. The maximum level measured on the spectrum analyser was recorded.

**Distance of antenna:** 3 meters

**Instrumentation test list:**

CATEGORY	BRAND	TYPE	N° EMITECH	Last validity date	Next validity date
Amplifier	Agilent	8449B	14487	11/05/2017	11/07/2018
Antenna	Emco	3115	0941	28/10/2015	28/12/2018
Antenna mast	Maturo	MCU	8410	---	---
Antenna mast	Maturo	AM 4.0	8411	---	---
Cable	C&C	N-10m	11136	01/04/2016	01/06/2018
Cable	C&C	N-8m	11174	18/04/2016	18/06/2018
Cable	C&C	N-2m	11178	16/04/2016	16/06/2018
Cable	C&C	N-2m	11182	20/04/2016	20/06/2018
Filter	BL Microwave	BP2442-84-7CS	5624	10/05/2017	10/07/2019
Receiver	Rohde & Schwarz	FSU8	9129	04/08/2016	04/10/2018
Shielded enclosure	SIDT	SIDT	0549	---	---

**Equipment under test operating condition:**

EUT is in continuous transmission mode.

**Measure conditions:**

Ambient temperature (°C): 21

Relative humidity (%): 39

Resolution bandwidth: 100 kHz

Video bandwidth: 300 kHz

**Results:**

Power source: 24 Vdc

Mode	Frequency	Electro-magnetic field (dB $\mu$ V/m)	PPSD * (dBm)	Limit (dBm)
b	2412 MHz	95.6	- 1.5	+ 8.0
	2442 MHz	96.2	- 1.8	
	2462 MHz	96.0	- 1.4	
g	2412 MHz	98.2	0.8	
	2442 MHz	94.8	- 2.5	
	2462 MHz	100.0	2.6	
n20	2412 MHz	98.6	1.2	
	2442 MHz	98.2	0.8	
	2462 MHz	97.3	0.8	
n40	2422 MHz	94.9	- 2.4	
	2437 MHz	94.5	- 2.9	
	2452 MHz	96.0	- 1.4	

 \* PPSD =  $(E \times d)^2 / (30 \times 1.64)$  for  $d = 3$  m

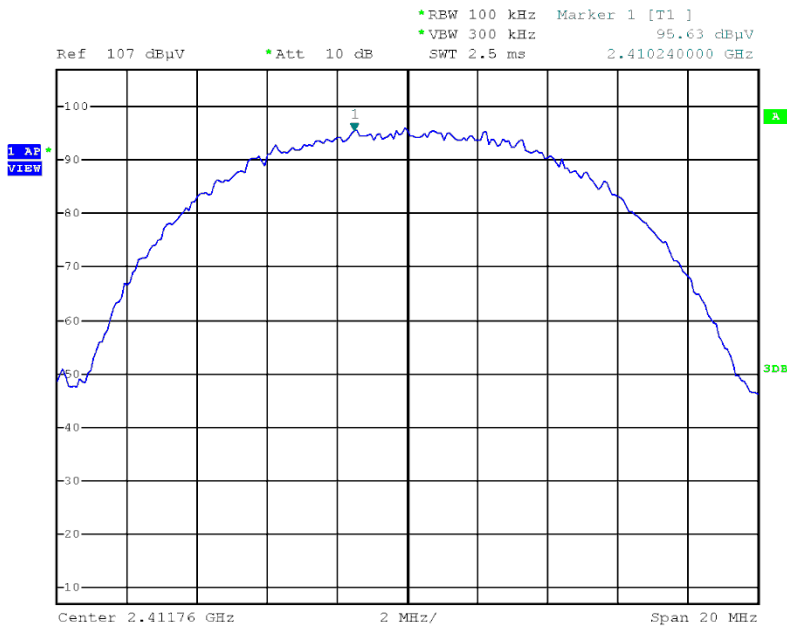
**Mode b**

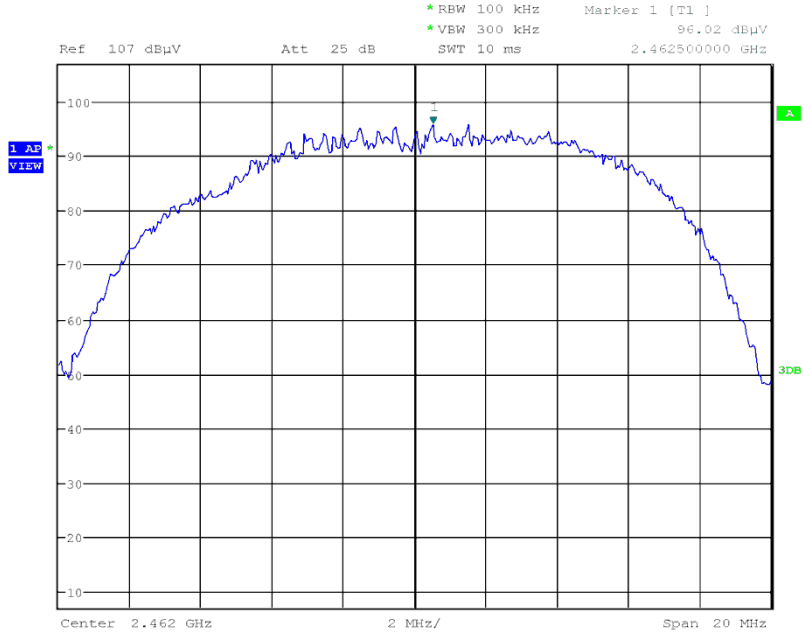
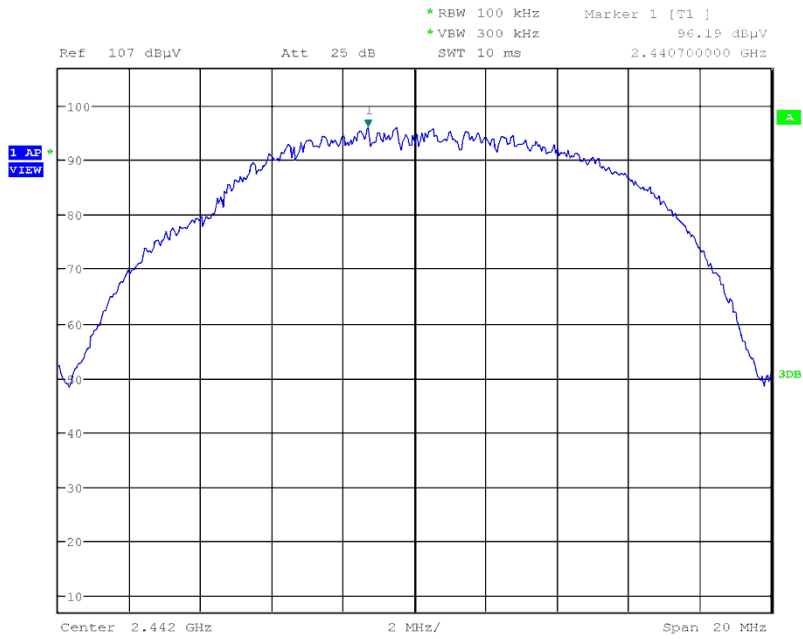

### Mode g

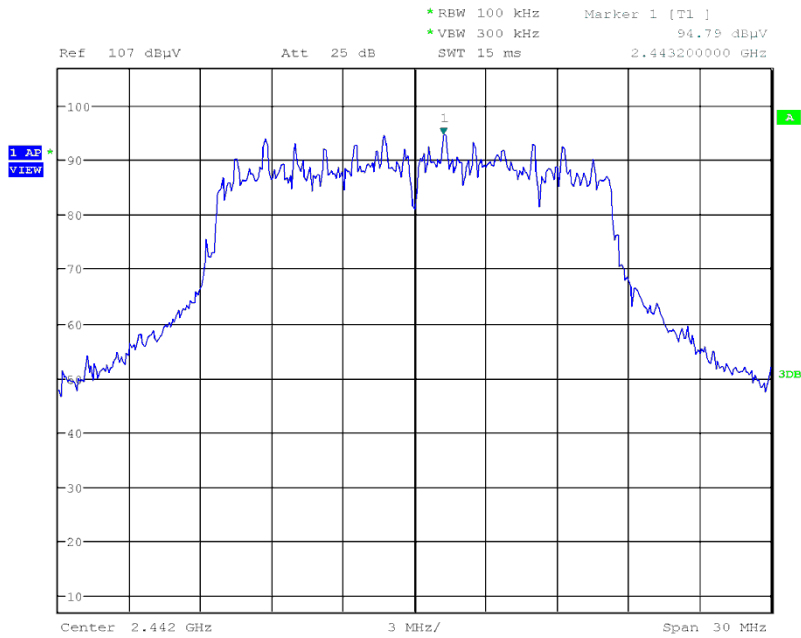
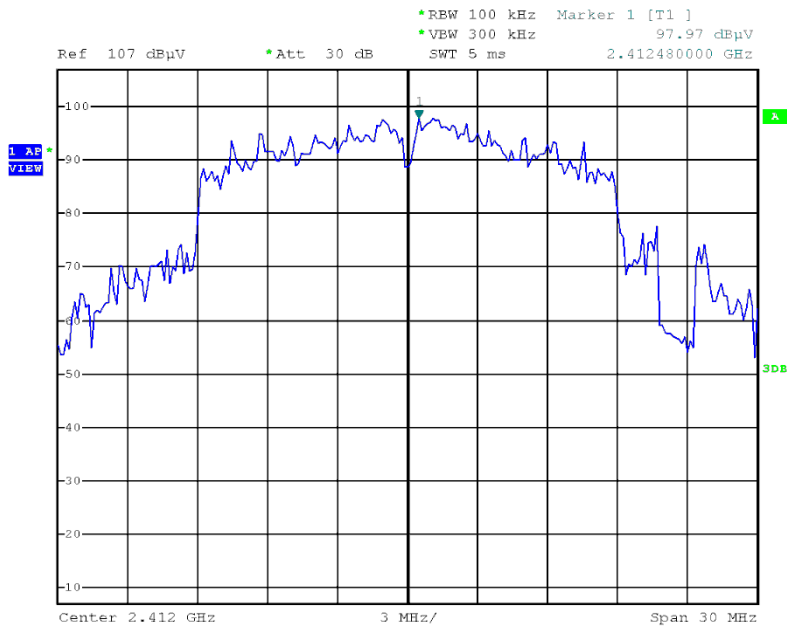



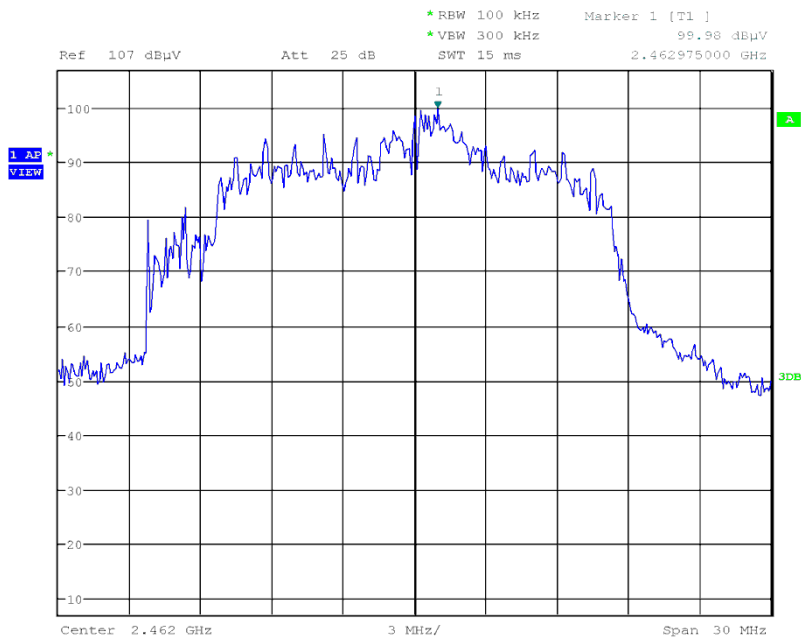

**Mode n20**

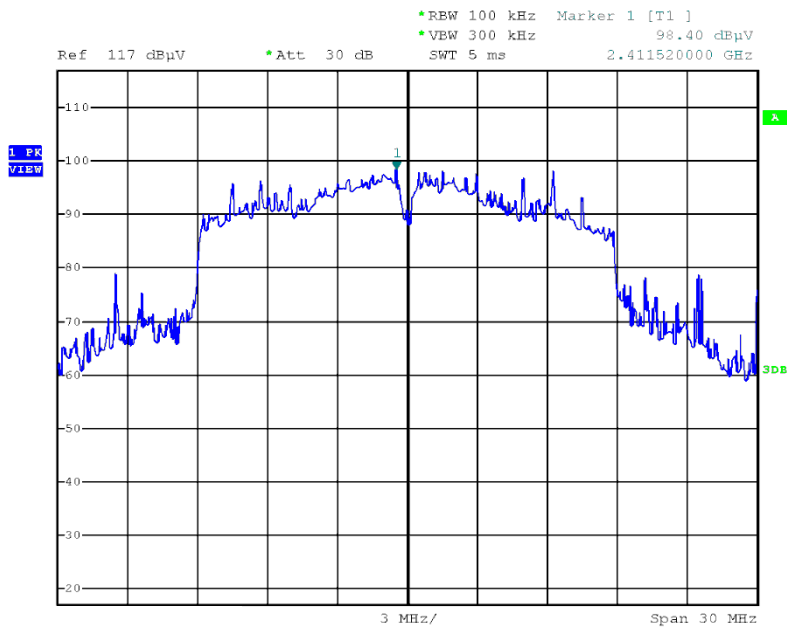

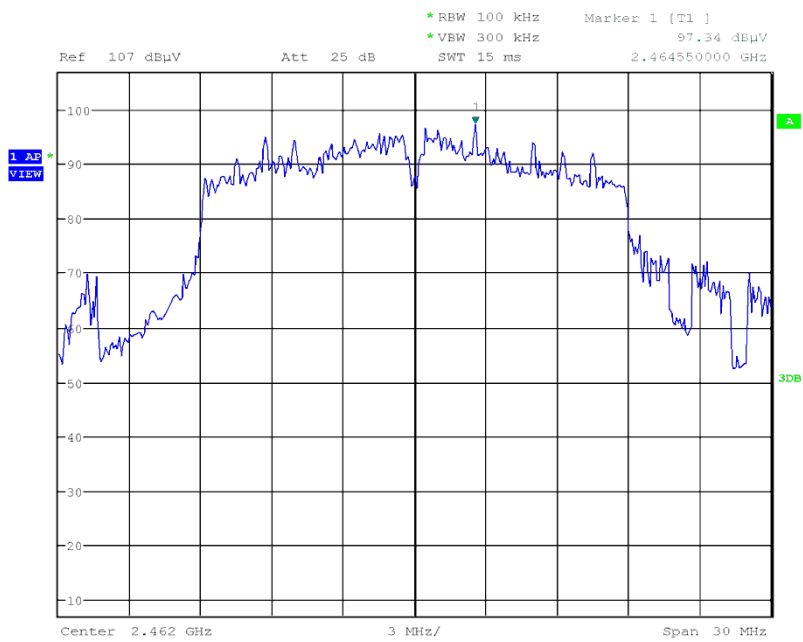
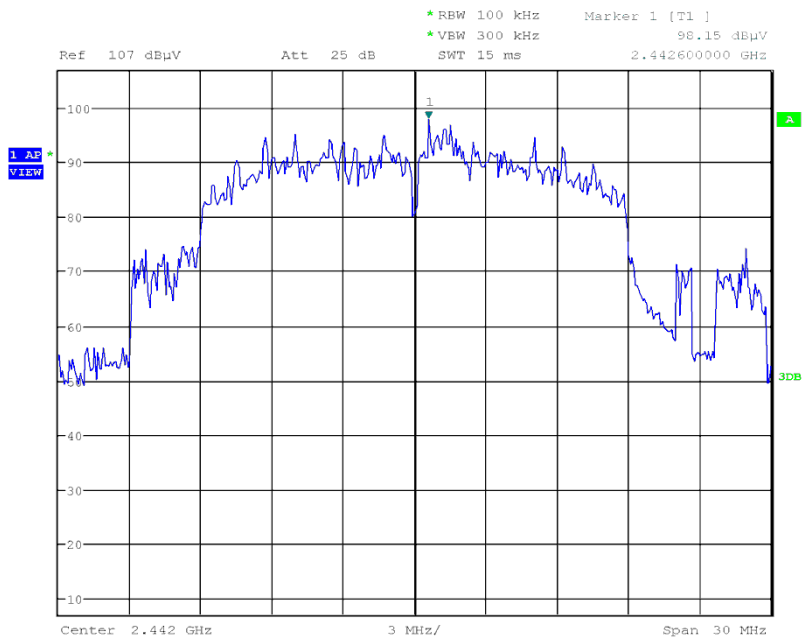

### Mode n40

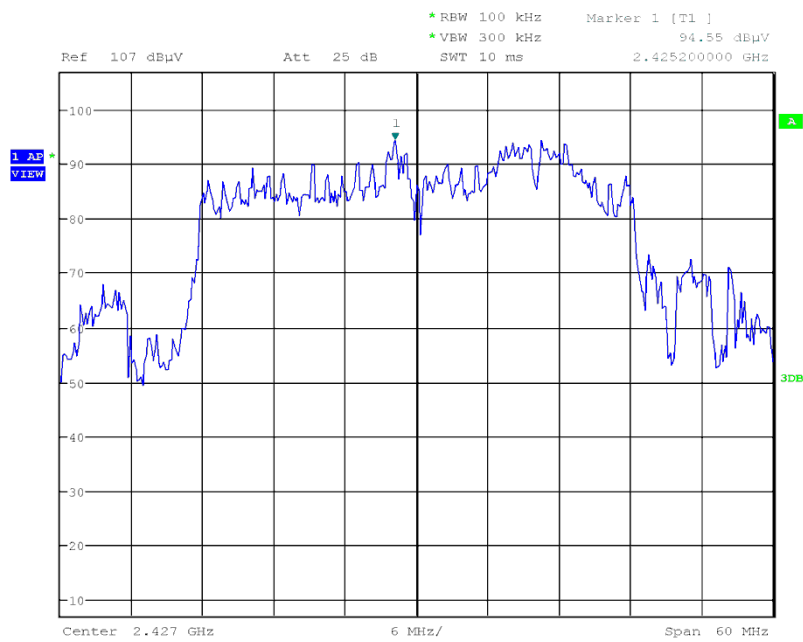
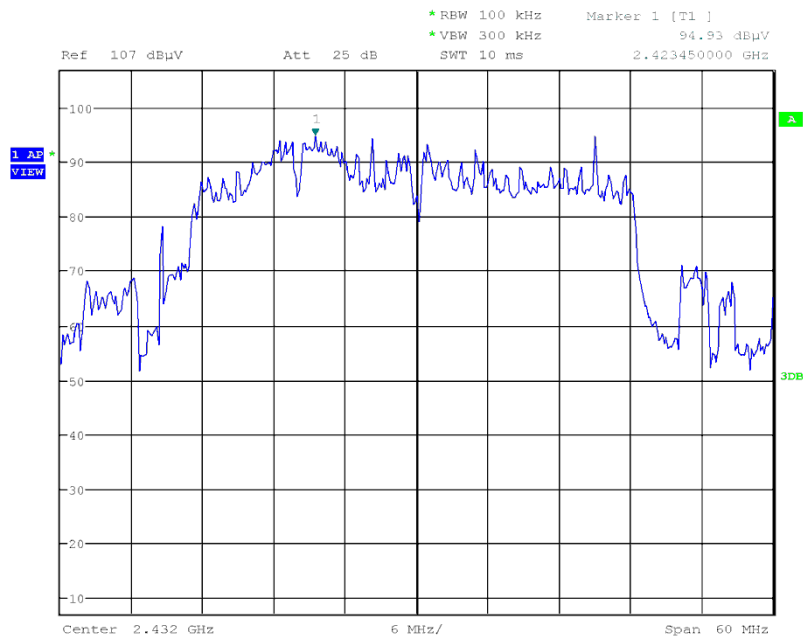

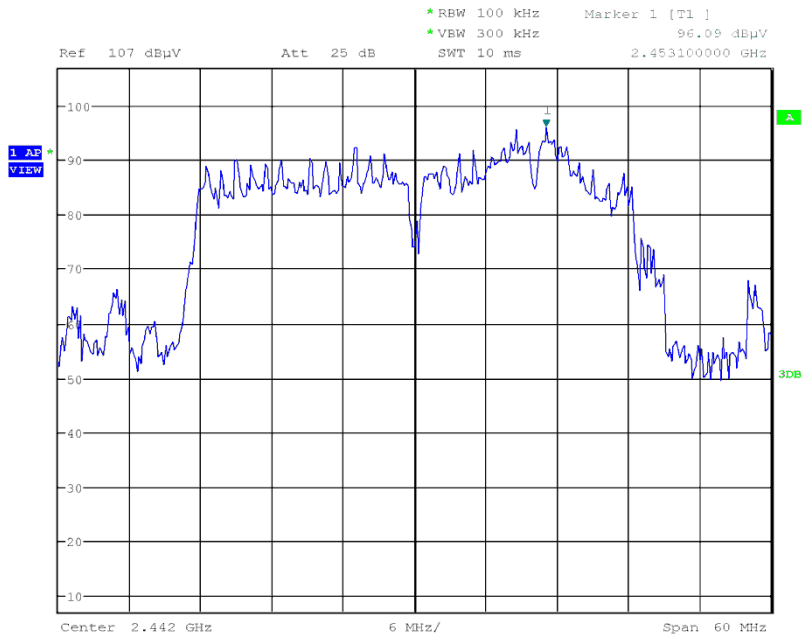

**Test conclusion:** Complies with the requirements of the standard.

<b>8. ADDITIONAL PROVISIONS TO THE GENERAL RADIATED EMISSIONS LIMITATION</b>
------------------------------------------------------------------------------

**Standard:** FCC 47 CFR PART 15 : 2015

**Sections:** §15.215 (b) and §15.247 (d)

**Instrumentation test list:**

CATEGORY	BRAND	TYPE	N° EMITECH	Last validity date	Next validity date
Amplifier	Agilent	8449B	14487	11/05/2017	11/07/2018
Antenna	Emco	3115	0941	28/10/2015	28/12/2018
Antenna mast	Maturo	MCU	8410	---	---
Antenna mast	Maturo	AM 4.0	8411	---	---
Cable	C&C	N-10m	11136	01/04/2016	01/06/2018
Cable	C&C	N-8m	11174	18/04/2016	18/06/2018
Cable	C&C	N-2m	11178	16/04/2016	16/06/2018
Cable	C&C	N-2m	11182	20/04/2016	20/06/2018
Filter	BL Microwave	BP2442-84-7CS	5624	10/05/2017	10/07/2019
Receiver	Rohde & Schwarz	FSU8	9129	04/08/2016	04/10/2018
Shielded enclosure	SIDT	SIDT	0549	---	---

**Equipment under test arrangement:**

The system is tested in normalized test site.

The test unit is placed on a rotating table, 0.8 m from a ground plane. Zero degree azimuth corresponds to the front of the equipment under test.

The level was maximised in antenna height, azimuth and polarization. The maximum level measured on the spectrum analyser was recorded.

**Results:**

Ambient temperature (°C): 21

Relative humidity (%): 39

Lower Band Edge: from 2310 MHz to 2390 MHz  
 Upper Band Edge: from 2483.5 MHz to 2500 MHz

**Mode b**

Polarization of test antenna: Vertical (height = 150 cm) } For 2412 MHz  
 Position of equipment: azimuth = 0°

Polarization of test antenna: Vertical (height = 150 cm) } For 2462 MHz  
 Position of equipment: azimuth = 140°

**Mode g**

Polarization of test antenna: Vertical (height = 142 cm) } For 2412 MHz  
 Position of equipment: azimuth = 0°

Polarization of test antenna: Vertical (height = 110 cm) } For 2462 MHz  
 Position of equipment: azimuth = 0°

**Mode n20**

Polarization of test antenna: Vertical (height = 150 cm) } For 2412 MHz  
 Position of equipment: azimuth = 0°

Polarization of test antenna: Vertical (height = 150 cm) } For 2462 MHz  
 Position of equipment: azimuth = 320°

**Mode n40**

Polarization of test antenna: Vertical (height = 150 cm) } For 2422 MHz  
 Position of equipment: azimuth = 0°

Polarization of test antenna: Vertical (height = 150 cm) } For 2422 MHz  
 Position of equipment: azimuth = 320°

Mode	Fundamental frequency (MHz)	Field Strength Level of fundamental (dB $\mu$ V/m)	Detector (Peak or Average)	Frequency of maximum Band-edges Emission (MHz)	Delta Marker (dB) *	Calculated Max Out of Band Emission Level (dB $\mu$ V/m)	Limits (dB $\mu$ V/m)	Margin (dB)
b	2411.5	90.2	Average	2316.2	50.4	39.8	54.0	14.2
	2463.9	78.8	Average	2489.02	45.4	33.4	54.0	20.6
g	2410.00	80.9	Average	2389.7	52.0	28.9	54.0	25.1
	2461.00	103..8	Average	2492.20	52.6	51.1	54.0	2.9
n20	2410.5	98.9	Average	2388.0	47.2	51.9	54.0	2.1
	2462.50	84.0	Average	2492.7	48.8	35.2	54.0	18.8
n40	2423.5	95.1	Average	2389.4	42.7	52.4	54.0	1.6
	2449.4	95.4	Average	2487.1	46.2	49.2	54.0	4.8

\* According to step 2 of Marker-Delta Method DA 00-705.

Band-edge curves are given in annex 4.

**9. UNINTENTIONAL RADIATED EMISSIONS AND TRANSMITTER UNWANTED EMISSION IN THE BAND 9 kHz – 25 GHz**

**Standard:** FCC 47 CFR PART 15 : 2015

**Section:** §15.205; 15.209 and §15.247

**Equipment under test arrangement:**

The equipment under test (EUT) is placed on a non-conductive test table at 0.8 m above the horizontal metal ground plane.

For maximum meter reading at each frequency, the antenna height is adjusted between 1 m and 4 m above the ground plane. A 360 degrees rotation of the EUT is performed in vertical and horizontal polarization. The frequency azimuth and antenna height are presented in the table on the next pages.

The E.U.T. is blocked in continuous transmission.

**Frequencies range:** 9 kHz – 30 MHz  
30 MHz - 1 GHz  
1 GHz – 25 GHz

**Detection mode:** Quasi-peak for 9 kHz – 30 MHz  
Quasi-peak for 30 MHz - 1 GHz  
Average for 1 GHz – 25 GHz

**Resolution bandwidth:** 200 Hz for 9 kHz – 150 kHz  
9 kHz for 150 kHz – 30 MHz  
120 kHz for 30 MHz - 1 GHz  
1 MHz for 1 GHz – 25 GHz

**Measurement distance:** 3 meters from 9 kHz to 30 MHz  
3 meters from 30 MHz to 25 GHz

- Limit for emission radiated outside the frequency band, except the harmonics, shall be attenuated by at least 20 dB below the level of fundamental or the general radiated emission limits.

From 9 kHz to 30 MHz

Frequencies range	Limit ( $\mu\text{V/m}$ )
9 – 490 kHz	2400/F (F in kHz) *
490 – 1705 kHz	24000/F (F in kHz) **
1.705 – 30 MHz	30 **

 \* Limits in  $\mu\text{V/m}$  can be extrapolated to 3 m using 40 dB / decade.

 \*\* Limits in  $\mu\text{V/m}$  can be extrapolated to 3 m using 20 dB / decade.

From 30 MHz to 25 GHz

Frequencies range (MHz)	Limit	
	(dB $\mu\text{V/m}$ )	( $\mu\text{V/m}$ )
30 to 88	40.0	100
88 to 216	43.5	150
216 to 960	46.0	200
Above 960	54.0	500

**Instrumentation test list:**

CATEGORY	BRAND	TYPE	N <sup>o</sup> EMITECH	Last validity date	Next validity date
Amplifier	Mini-circuit	ZFL-1000LN	6367	14/09/2016	14/11/2017
Amplifier	Agilent	8449B	14487	11/05/2017	11/07/2018
Antenna	Schwarzbeck	VHA 9103	0317	18/02/2015	18/04/2018
Antenna	Emco	3115	0941	28/10/2015	28/12/2018
Antenna	Oritel	CM 42/25	1045	21/03/2015	21/05/2018
Antenna	Schwarzbeck	UHALP 9108	3106	07/04/2017	07/06/2019
Antenna	Emco	6502	9579	10/04/2017	10/06/2019
Antenna mast	Maturo	MCU	8410	---	---
Antenna mast	Maturo	AM 4.0	8411	---	---
Cable	C&C	K-2m	11132	15/04/2016	15/06/2018
Cable	C&C	K-2m	11133	15/04/2016	15/06/2018
Cable	C&C	N-10m	11136	01/04/2016	01/06/2018
Cable	C&C	N-8m	11174	18/04/2016	18/06/2018
Cable	C&C	N-2m	11178	16/04/2016	16/06/2018
Cable	C&C	N-2m	11182	20/04/2016	20/06/2018
Cable	Sucoflex	N-2m	12936	29/04/2016	29/06/2018
Filter	Micro-Tronics	HPM 14758	4691	10/05/2017	10/07/2019
Shielded enclosure	SIDT	C.4	0549	---	---
Spectrum analyzer	Rohde & Schwarz	FSP40 (V 4.00SP1-V3.0-10-2)	5175	01/04/2016	01/06/2018
Spectrum analyzer	Rohde & Schwarz	ESR7	12811	01/08/2017	01/10/2018



### Results:

Ambient temperature (°C): 21  
 Relative humidity (%): 39  
 Power source: 24 Vdc

### Mode b

Frequency 2412 MHz

Frequency (MHz)	Polarization	Height (cm)	Azimuth (°)	Field Strength Level (dB $\mu$ V/m)	Limit (dB $\mu$ V/m)
32.00	Horizontal	400	240	37.2	40
400.00	Vertical	100	0	32.2	46
4837.88	Horizontal	150	0	29.7	54

No more significant frequency has been found other than those.

Frequency 2442 MHz

Frequency (MHz)	Polarization	Height (cm)	Azimuth (°)	Field Strength Level (dB $\mu$ V/m)	Limit (dB $\mu$ V/m)
32.00	Horizontal	400	240	37.2	40
400.00	Vertical	100	0	32.2	46
4837.88	Horizontal	150	0	29.7	54

No more significant frequency has been found other than those

Frequency 2462 MHz

Frequency (MHz)	Polarization	Height (cm)	Azimuth (°)	Field Strength Level (dB $\mu$ V/m)	Limit (dB $\mu$ V/m)
32.00	Horizontal	400	240	37.2	40
400.00	Vertical	100	0	32.2	46
4931.95	Horizontal	150	0	41.1	54

No more significant frequency has been found other than those.

### Mode g

Frequency 2412 MHz

Frequency (MHz)	Polarization	Height (cm)	Azimuth (°)	Field Strength Level (dB $\mu$ V/m)	Limit (dB $\mu$ V/m)
32.00	Horizontal	400	240	37.2	40
400.00	Vertical	100	0	32.2	46
4842.00	Horizontal	150	0	42.5	54

No more significant frequency has been found other than those.

Frequency 2442 MHz

Frequency (MHz)	Polarization	Height (cm)	Azimuth (°)	Field Strength Level (dB $\mu$ V/m)	Limit (dB $\mu$ V/m)
32.00	Horizontal	400	240	37.2	40
400.00	Vertical	100	0	32.2	46
4842.00	Horizontal	150	0	42.5	54

No more significant frequency has been found other than those.

Frequency 2462 MHz

Frequency (MHz)	Polarization	Height (cm)	Azimuth (°)	Field Strength Level (dB $\mu$ V/m)	Limit (dB $\mu$ V/m)
32.00	Horizontal	400	240	37.2	40
400.00	Vertical	100	0	32.2	46
4931.95	Horizontal	150	280	40.9	54

No more significant frequency has been found other than those.

### Mode n20

Frequency 2412 MHz

Frequency (MHz)	Polarization	Height (cm)	Azimuth (°)	Field Strength Level (dB $\mu$ V/m)	Limit (dB $\mu$ V/m)
32.00	Horizontal	400	240	37.2	40
400.00	Vertical	100	0	32.2	46
4834.01	Horizontal	150	0	33.6	54

No more significant frequency has been found other than those.

Frequency 2442 MHz

Frequency (MHz)	Polarization	Height (cm)	Azimuth (°)	Field Strength Level (dB $\mu$ V/m)	Limit (dB $\mu$ V/m)
32.00	Horizontal	400	240	37.2	40
400.00	Vertical	100	0	32.2	46
4834.01	Horizontal	150	0	33.6	54

No more significant frequency has been found other than those.

Frequency 2462 MHz

Frequency (MHz)	Polarization	Height (cm)	Azimuth (°)	Field Strength Level (dB $\mu$ V/m)	Limit (dB $\mu$ V/m)
32.00	Horizontal	400	240	37.2	40
400.00	Vertical	100	0	32.2	46
4931.90	Horizontal	150	75	38.8	54

No more significant frequency has been found other than those.

**Mode n40**

Frequency 2422 MHz

Frequency (MHz)	Polarization	Height (cm)	Azimuth (°)	Field Strength Level (dB $\mu$ V/m)	Limit (dB $\mu$ V/m)
32.00	Horizontal	400	240	37.2	40
400.00	Vertical	100	0	32.2	46
4834.01	Horizontal	150	0	33.6	54

No more significant frequency has been found other than those.

Frequency 2437 MHz

Frequency (MHz)	Polarization	Height (cm)	Azimuth (°)	Field Strength Level (dB $\mu$ V/m)	Limit (dB $\mu$ V/m)
32.00	Horizontal	400	240	37.2	40
400.00	Vertical	100	0	32.2	46
4834.01	Horizontal	150	0	33.6	54

No more significant frequency has been found other than those.

Frequency 2452 MHz

Frequency (MHz)	Polarization	Height (cm)	Azimuth (°)	Field Strength Level (dB $\mu$ V/m)	Limit (dB $\mu$ V/m)
32.00	Horizontal	400	240	37.2	40
400.00	Vertical	100	0	32.2	46
4931.90	Horizontal	150	75	38.8	54

No more significant frequency has been found other than those.

**Test conclusion:**

The equipment complies with the requirements of the standard.

« □□□ End of report, 4 annexes to be forwarded □□□ »

# ANNEX 1:

## *EXTERNAL PHOTOGRAPHS*



# ANNEX 2:

## *TEST SETUP PHOTOGRAPHS*

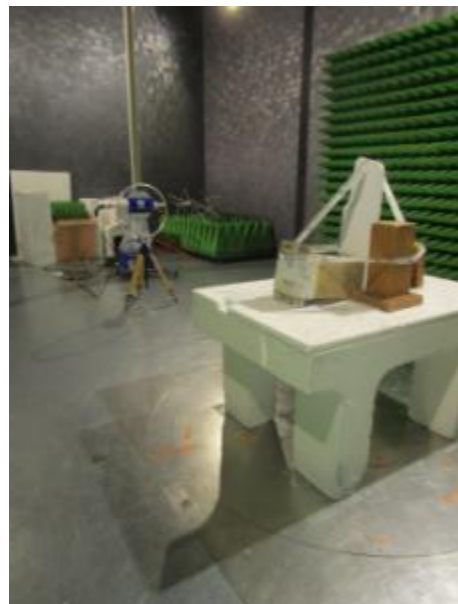
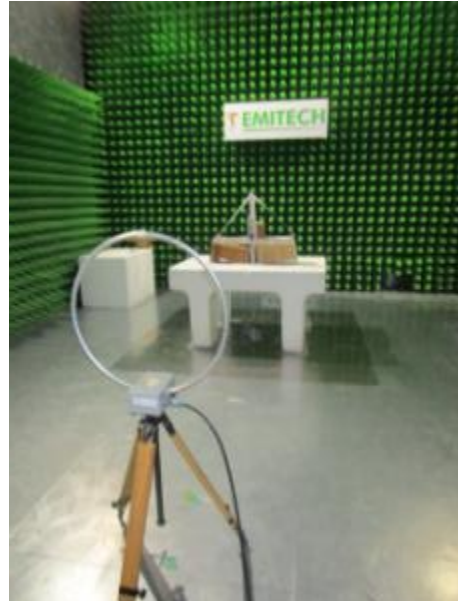
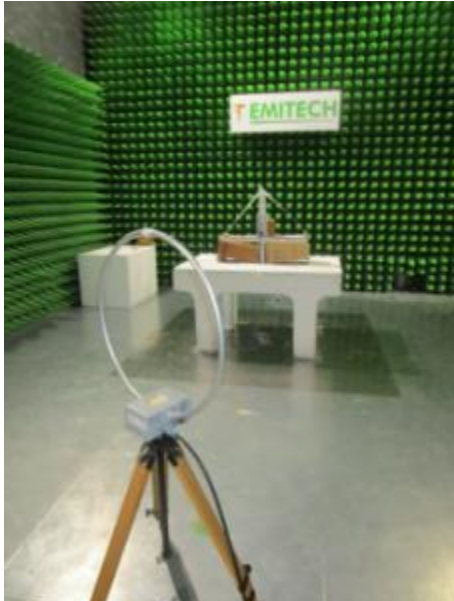







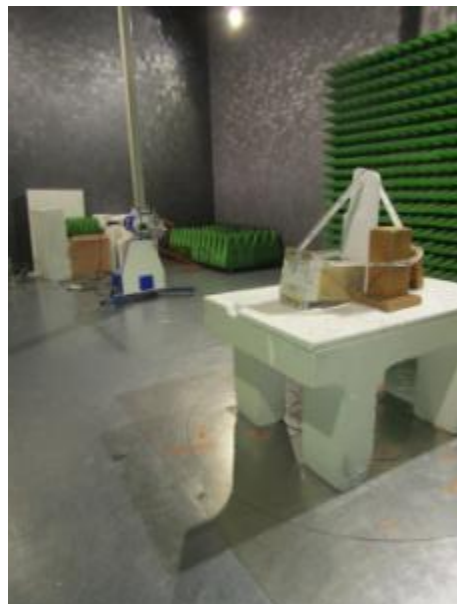
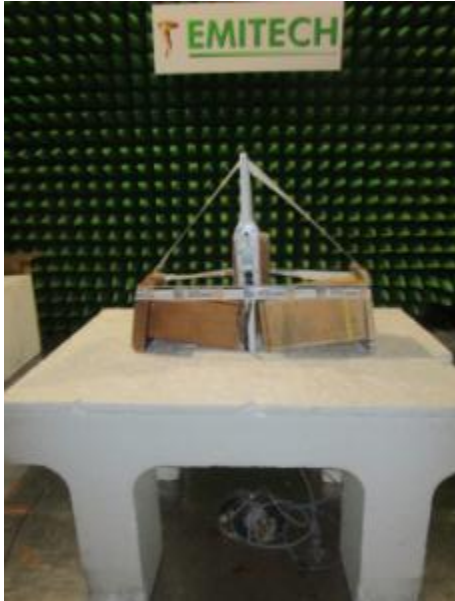

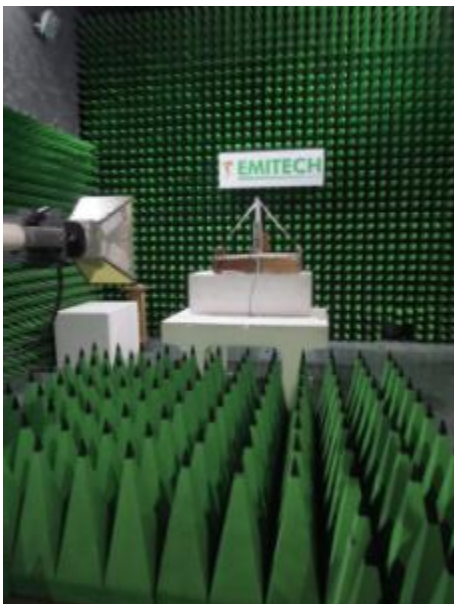
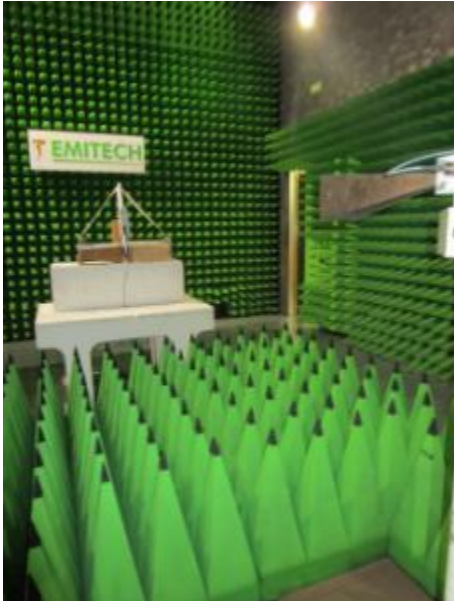



## ANNEX 3:

*6 dB BANDWIDTH*  
*20 dB BANDWIDTH*

## 6 dB BANDWIDTH

### Mode b

### Frequency 2412 MHz

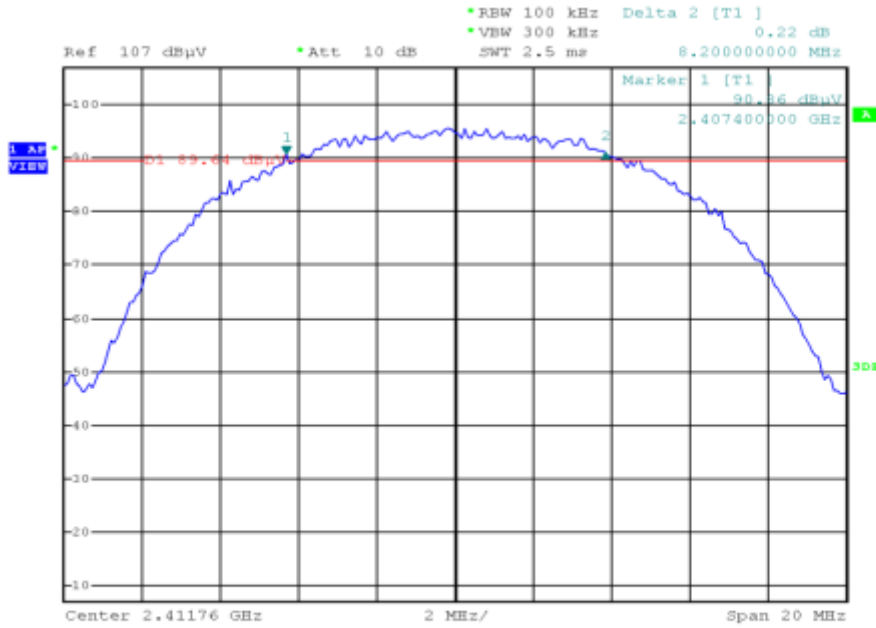

### Frequency 2442 MHz



Frequency 2462 MHz



Mode g

Frequency 2412 MHz

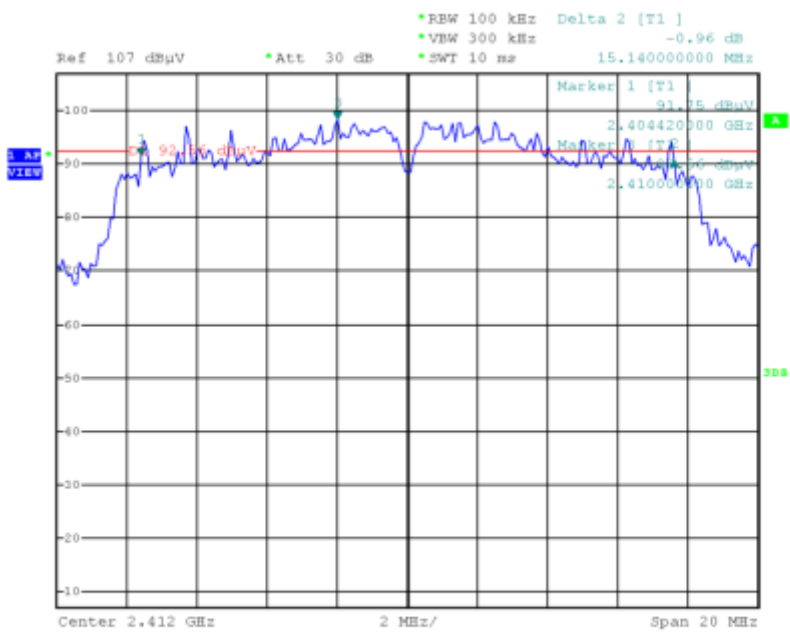



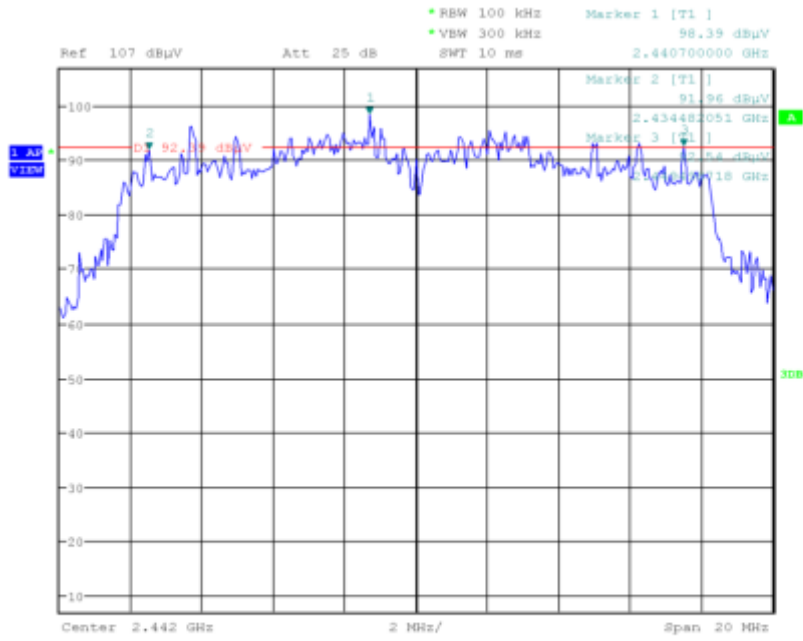

Frequency 2462 MHz



Date: 5.DEC.2017 04:46:25

Mode n20

Frequency 2412 MHz

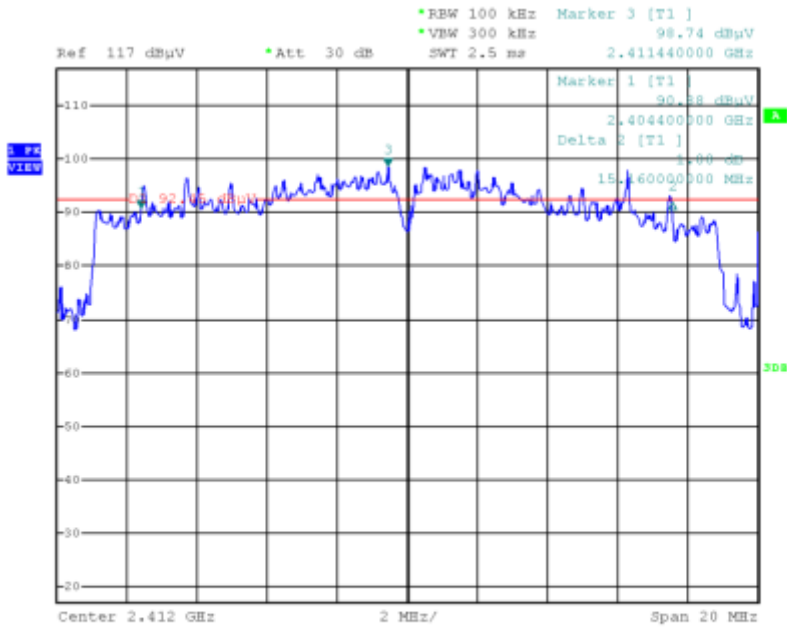

Frequency 2442 MHz

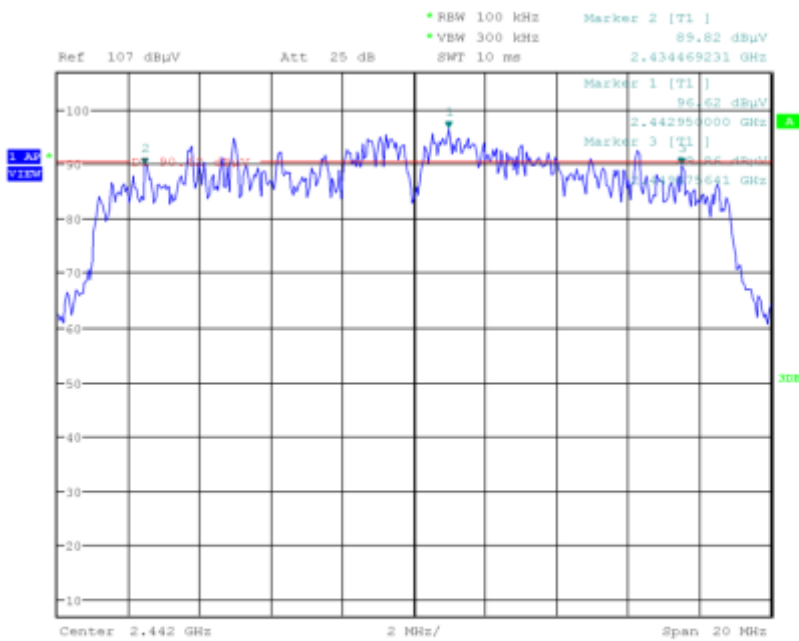



Frequency 2462 MHz

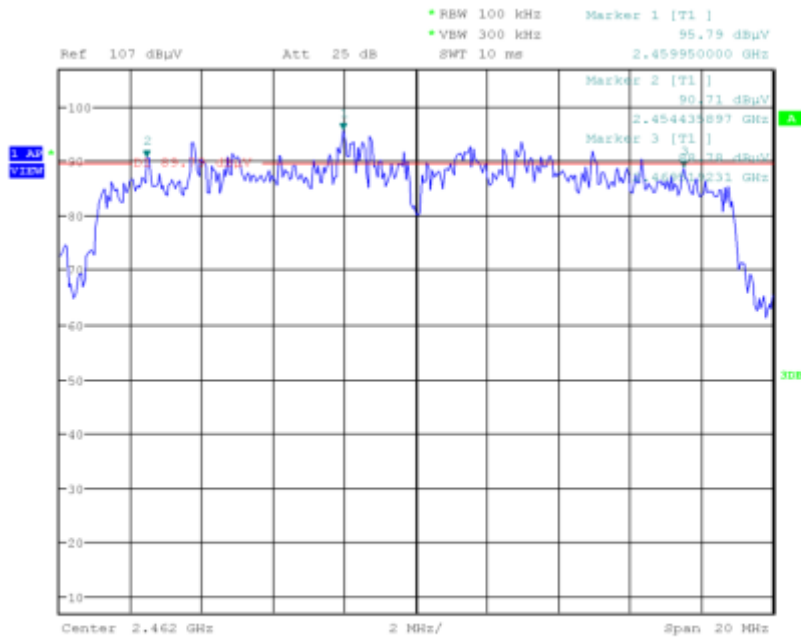

Mode n40

Frequency 2422 MHz

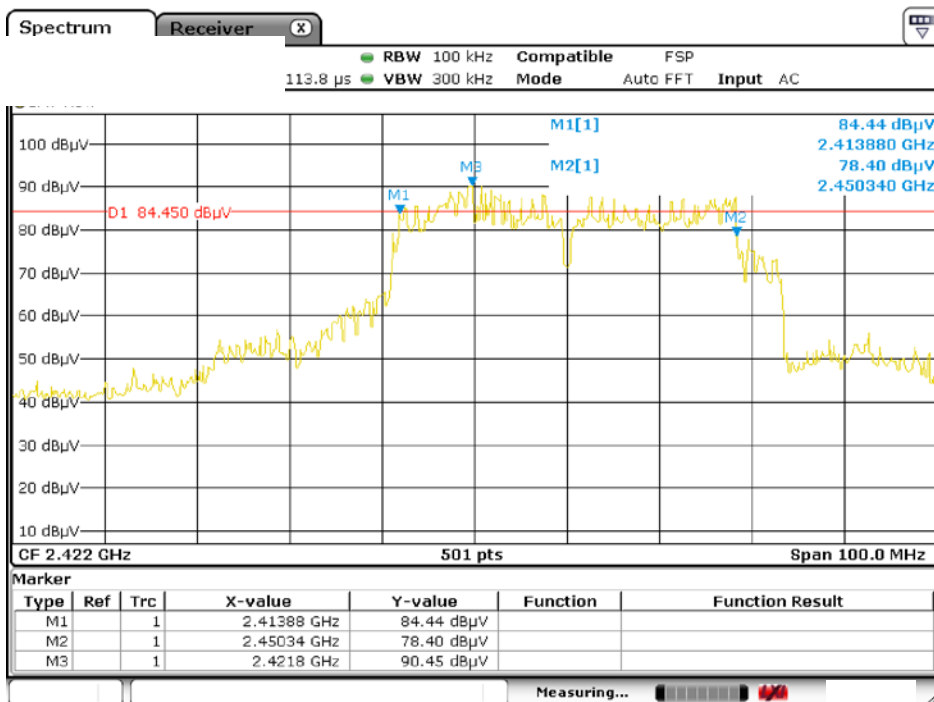

Frequency 2437 MHz

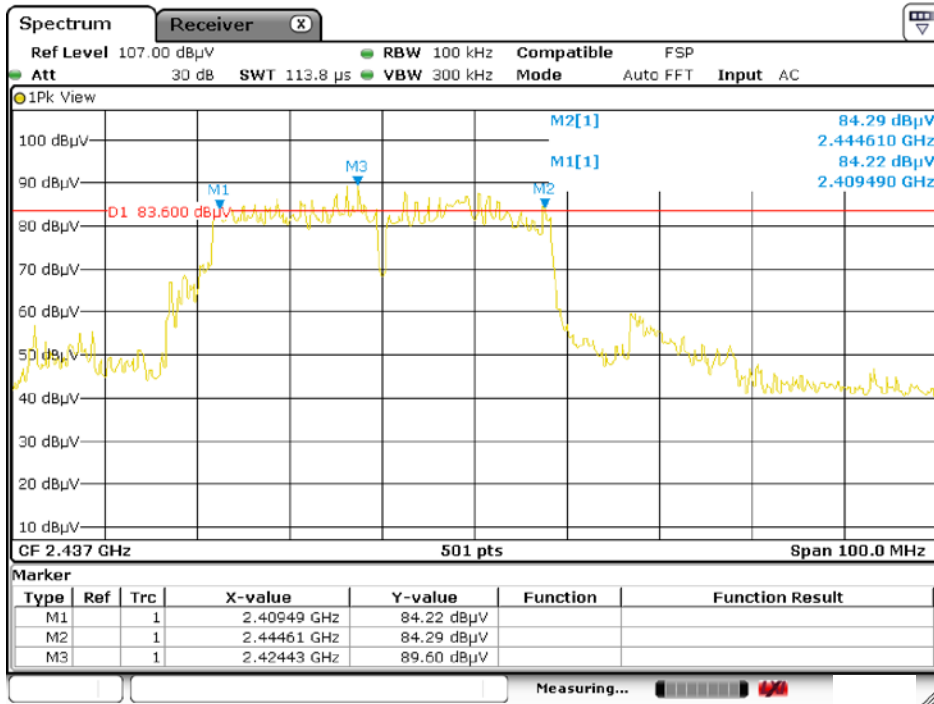

Frequency 2462 MHz

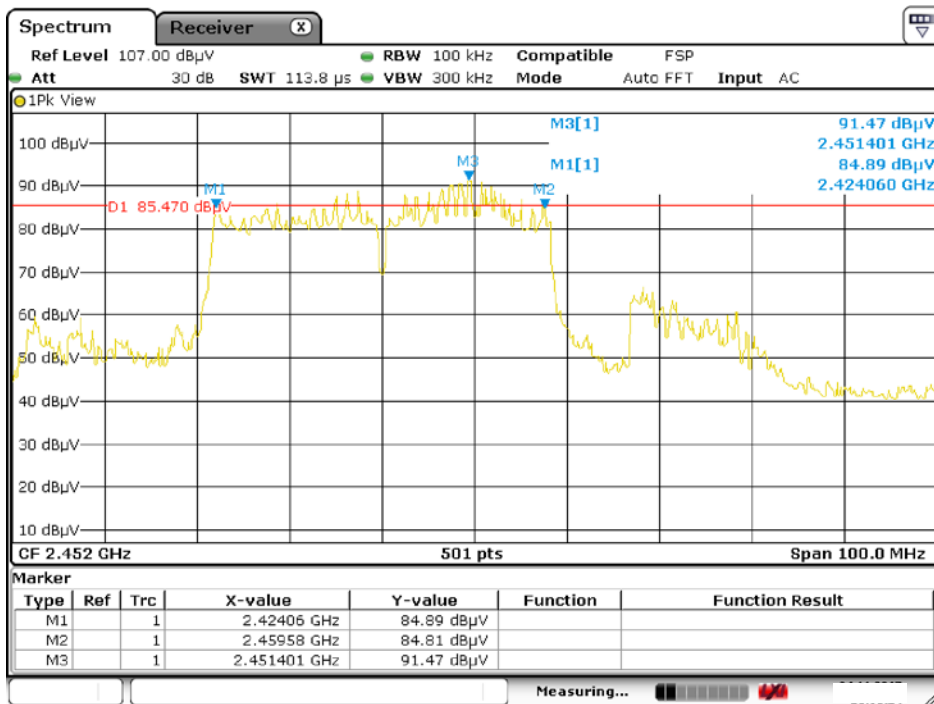

## 20 dB BANDWIDTH

### Mode b

Frequency 2412 MHz

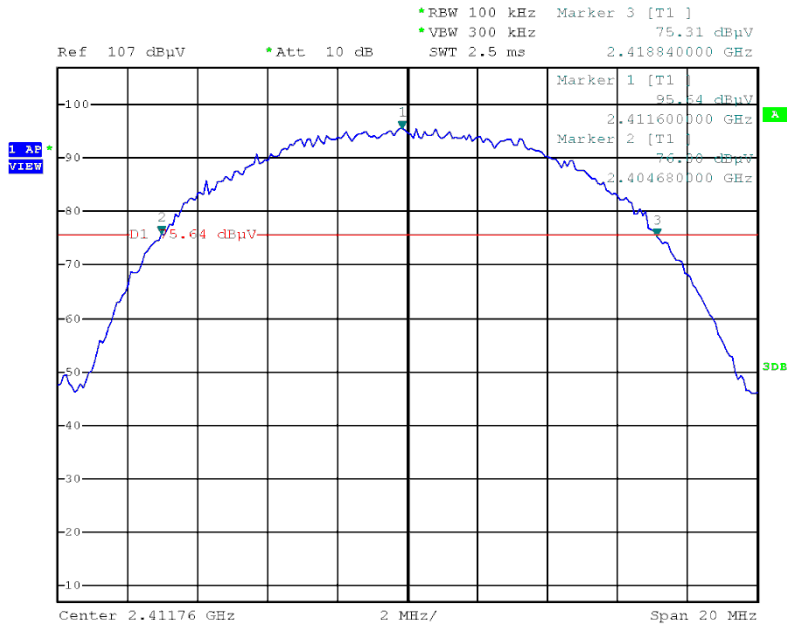

Frequency 2442 MHz

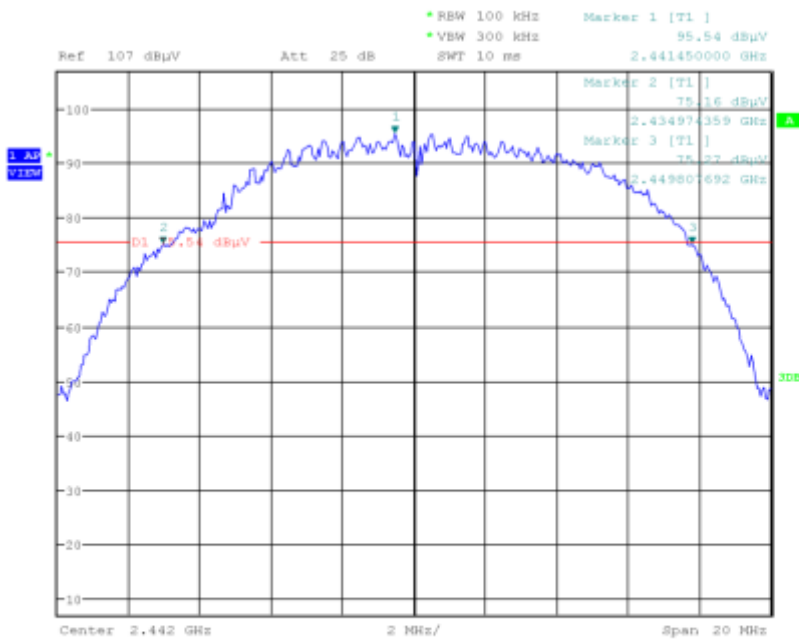

Frequency 2462 MHz

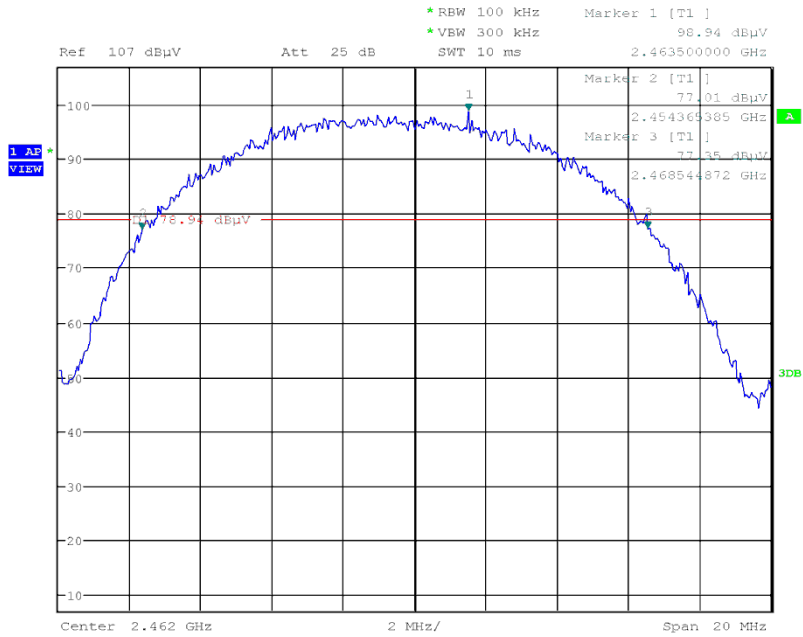

Mode g

Frequency 2412 MHz

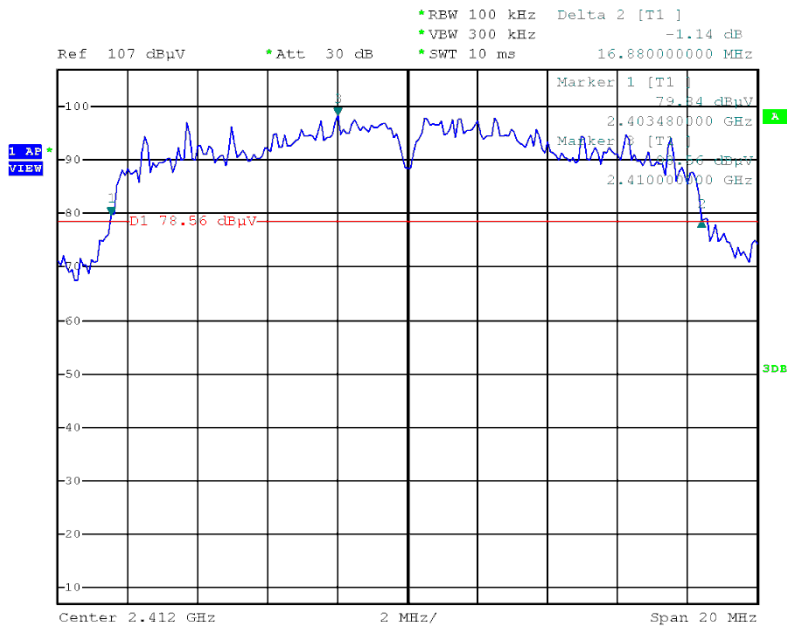

Frequency 2442 MHz

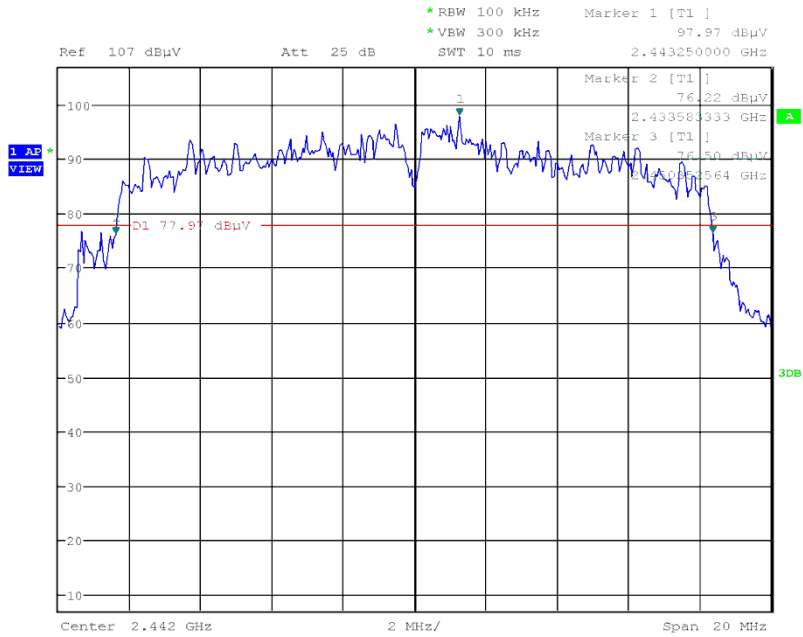

Frequency 2462 MHz

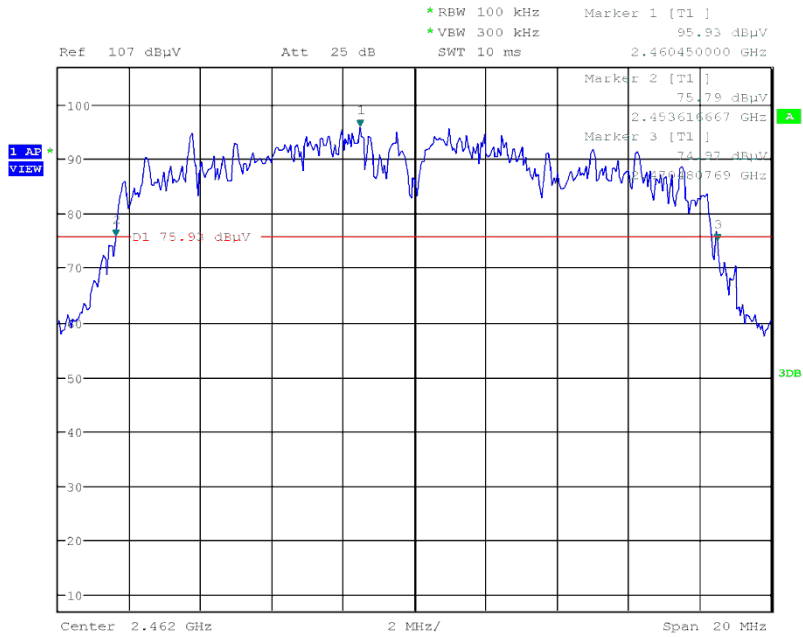

Mode n20

Frequency 2412 MHz

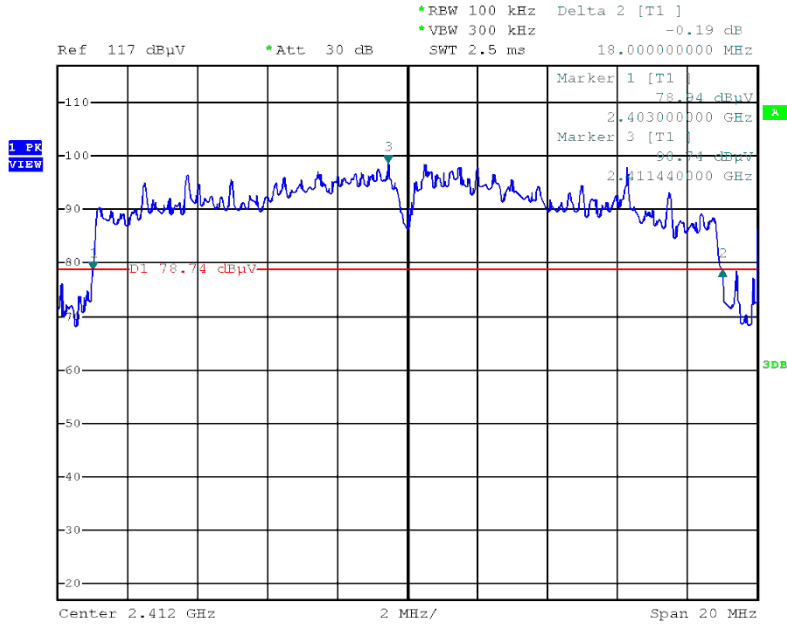

Frequency 2442 MHz



Frequency 2462 MHz

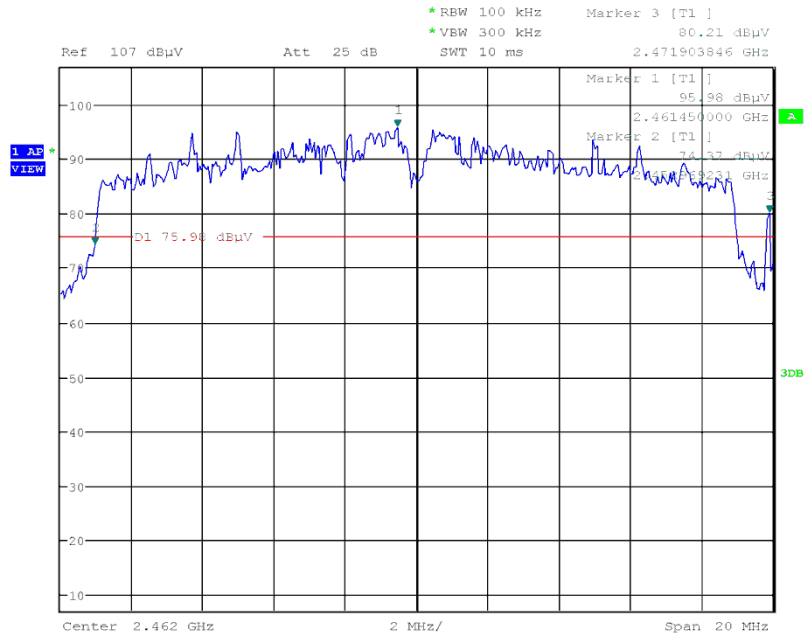

Mode n40

Frequency 2412 MHz

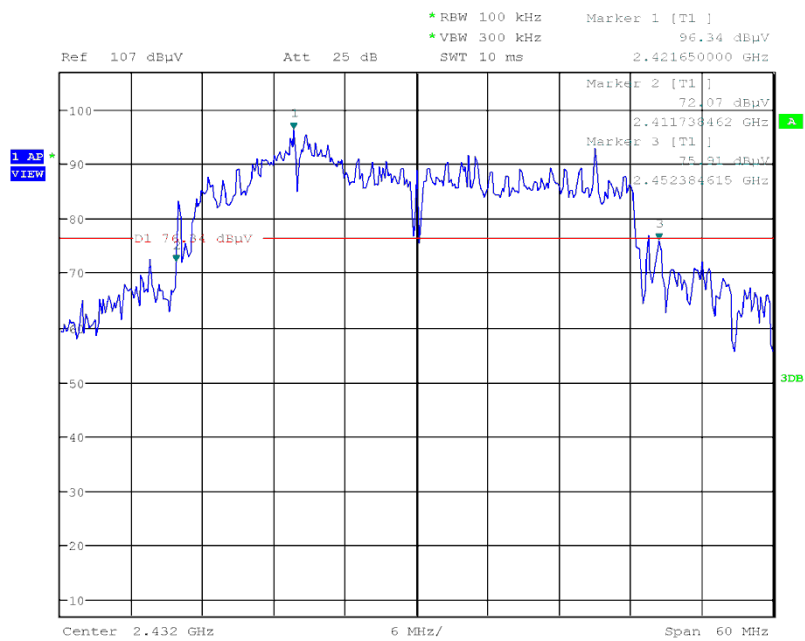

Frequency 2442 MHz

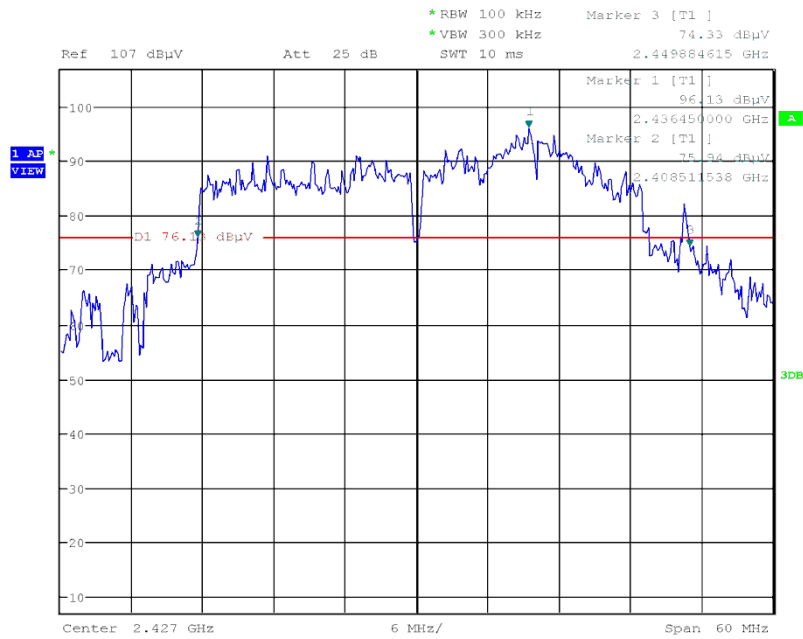

Frequency 2462 MHz

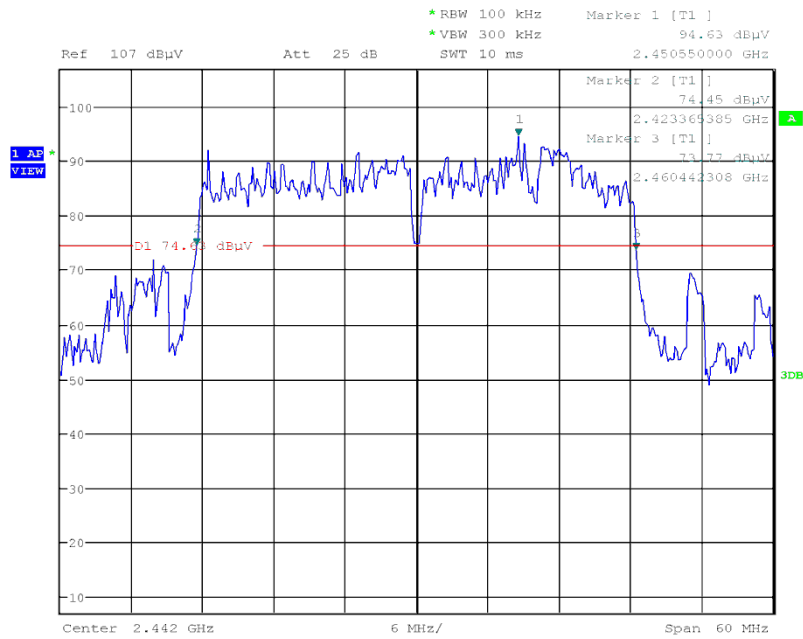



# ANNEX 4:

## *BAND EDGE*

### Mode b

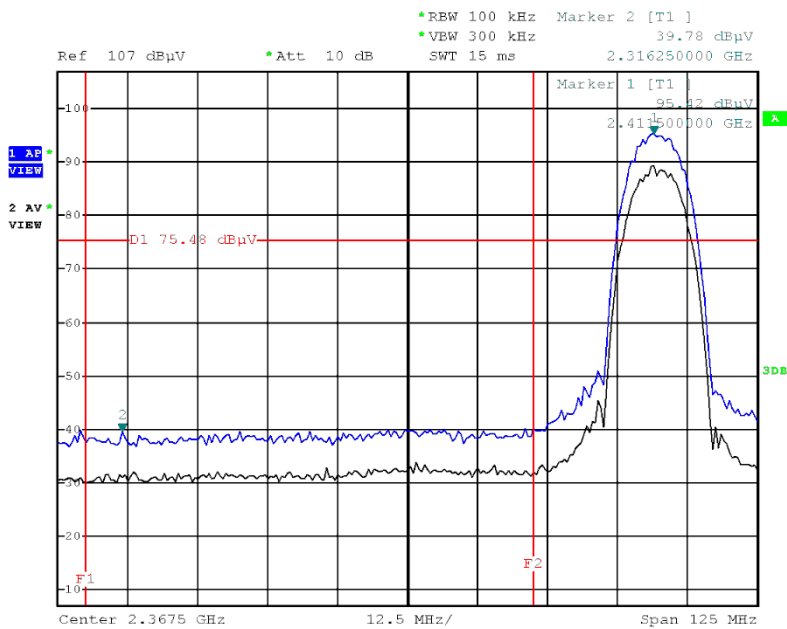
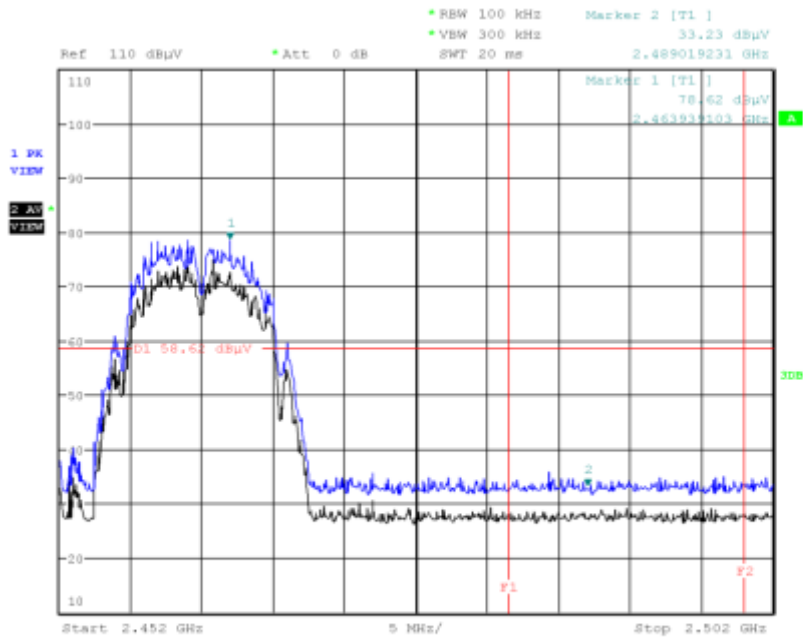

### Mode g

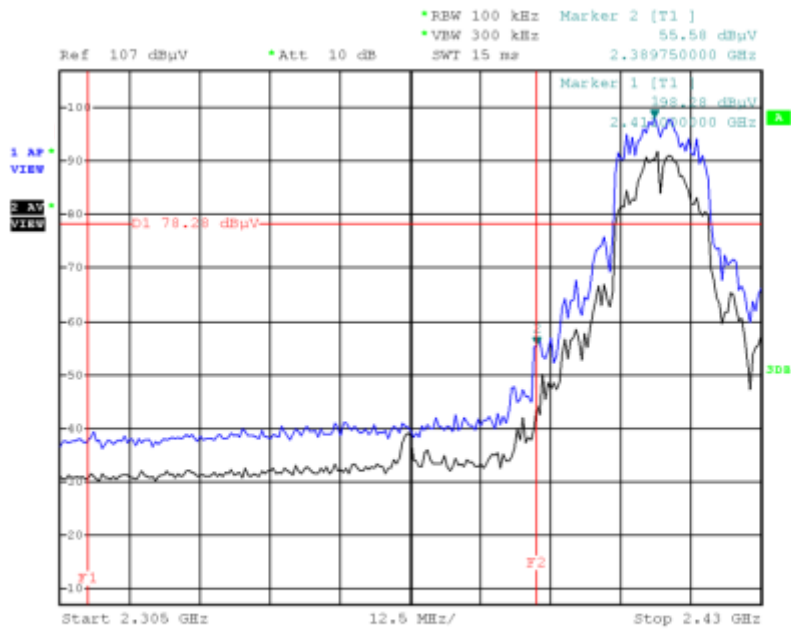
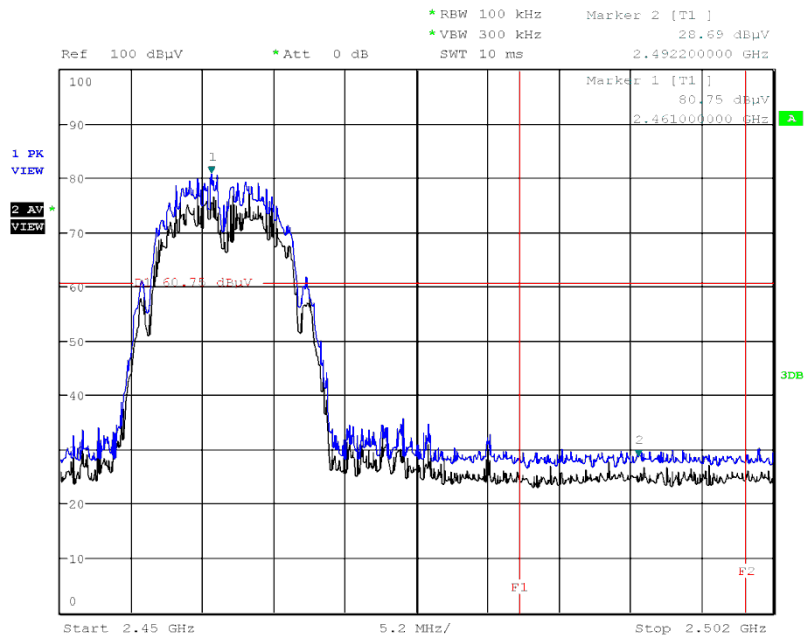

mode n20

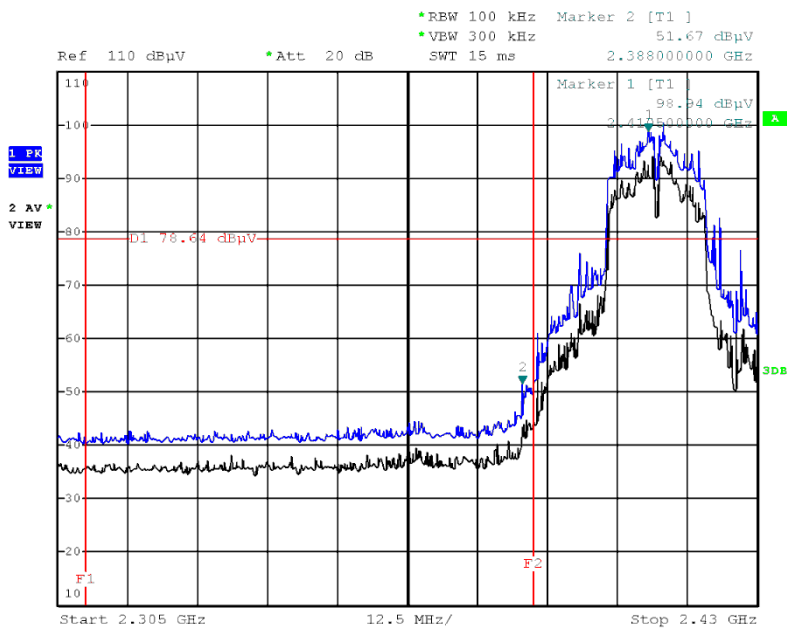
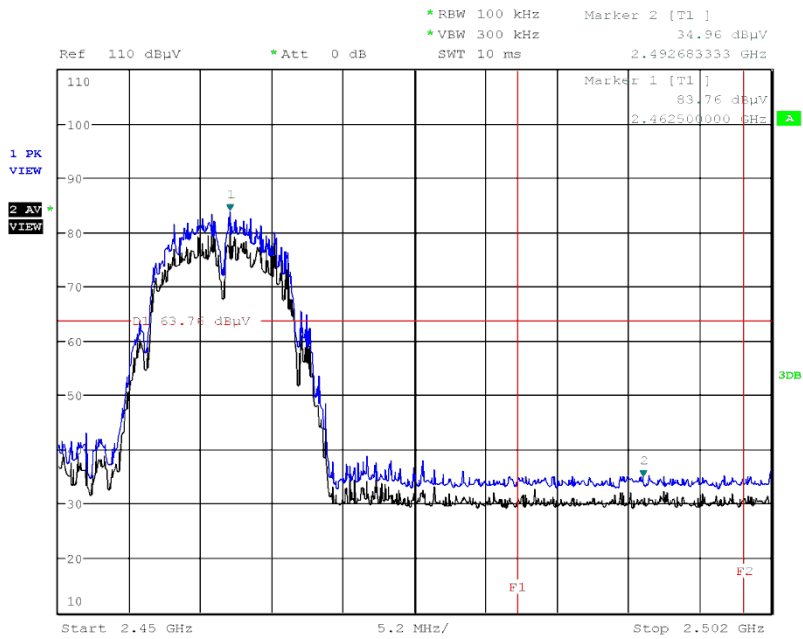

mode n40

