

APPLICATION CERTIFICATION FCC Part 15C
On Behalf of
GOOD EVER TRADING LIMITED

True Wireless BT Earbuds

Model No.: CB-TE008, 20248, TBE-8/1751, AA-TWSSE

FCC ID: 2AM7T-CBTE008

Prepared for : GOOD EVER TRADING LIMITED
Address : Rm1701, Zhuoyue Building, Fuhua Yi Rd., Futian Central Zone,
Shenzhen, P.R.China

Prepared by : Shenzhen Accurate Technology Co., Ltd.
Address : 1/F., Building A, Changyuan New Material Port, Science & Industry
Park, Nanshan District, Shenzhen, Guangdong, P.R. China

Tel: (0755) 26503290
Fax: (0755) 26503396

Report No. : ATE2020200378
Date of Test : May 6-7, 2020
Date of Report : May 8, 2020

TABLE OF CONTENTS

| Description | Page |
|---|-----------|
| Test Report Certification | |
| TABLE OF CONTENTS | 2 |
| 1. GENERAL INFORMATION | 5 |
| 1.1. Description of Device (EUT)..... | 5 |
| 1.2. Accessory and Auxiliary Equipment | 5 |
| 1.3. Description of Test Facility | 6 |
| 1.4. Measurement Uncertainty | 6 |
| 2. MEASURING DEVICE AND TEST EQUIPMENT | 7 |
| 3. OPERATION OF EUT DURING TESTING | 8 |
| 3.1. Operating Mode | 8 |
| 3.2. Configuration and peripherals | 8 |
| 4. TEST PROCEDURES AND RESULTS | 9 |
| 5. 20DB BANDWIDTH TEST | 10 |
| 5.1. Block Diagram of Test Setup..... | 10 |
| 5.2. The Requirement For Section 15.247(a)(1)..... | 10 |
| 5.3. EUT Configuration on Measurement | 10 |
| 5.4. Operating Condition of EUT | 10 |
| 5.5. Test Procedure | 10 |
| 5.6. Test Result | 11 |
| 6. CARRIER FREQUENCY SEPARATION TEST | 15 |
| 6.1. Block Diagram of Test Setup..... | 15 |
| 6.2. The Requirement For Section 15.247(a)(1)..... | 15 |
| 6.3. EUT Configuration on Measurement | 15 |
| 6.4. Operating Condition of EUT | 15 |
| 6.5. Test Procedure | 16 |
| 6.6. Test Result | 16 |
| 7. NUMBER OF HOPPING FREQUENCY TEST | 20 |
| 7.1. Block Diagram of Test Setup..... | 20 |
| 7.2. The Requirement For Section 15.247(a)(1)(iii)..... | 20 |
| 7.3. EUT Configuration on Measurement | 20 |
| 7.4. Operating Condition of EUT | 20 |
| 7.5. Test Procedure | 20 |
| 7.6. Test Result | 21 |
| 8. DWELL TIME TEST | 23 |
| 8.1. Block Diagram of Test Setup..... | 23 |
| 8.2. The Requirement For Section 15.247(a)(1)(iii)..... | 23 |
| 8.3. EUT Configuration on Measurement | 23 |
| 8.4. Operating Condition of EUT | 23 |
| 8.5. Test Procedure | 23 |
| 8.6. Test Result | 24 |
| 9. MAXIMUM PEAK OUTPUT POWER TEST | 28 |
| 9.1. Block Diagram of Test Setup..... | 28 |

- 9.2. The Requirement For Section 15.247(b)(1).....28
- 9.3. EUT Configuration on Measurement28
- 9.4. Operating Condition of EUT28
- 9.5. Test Procedure28
- 9.6. Test Result29
- 10. RADIATED EMISSION TEST 33**
- 10.1. Block Diagram of Test Setup.....33
- 10.2. The Limit For Section 15.247(d)34
- 10.3. Restricted bands of operation36
- 10.4. Configuration of EUT on Measurement36
- 10.5. Operating Condition of EUT37
- 10.6. Test Procedure37
- 10.7. Data Sample.....38
- 10.8. Test Results.....38
- 11. BAND EDGE COMPLIANCE TEST 51**
- 11.1. Block Diagram of Test Setup.....51
- 11.2. The Requirement For Section 15.247(d)51
- 11.3. EUT Configuration on Measurement51
- 11.4. Operating Condition of EUT51
- 11.5. Test Procedure52
- 11.6. Test Result52
- 12. AC POWER LINE CONDUCTED EMISSION TEST 62**
- 12.1. Block Diagram of Test Setup.....62
- 12.2. Power Line Conducted Emission Measurement Limits.....63
- 12.3. Configuration of EUT on Measurement63
- 12.4. Operating Condition of EUT63
- 12.5. Test Procedure63
- 12.6. Data Sample.....64
- 12.7. Test Results.....64
- 13. ANTENNA REQUIREMENT..... 67**
- 13.1. The Requirement67
- 13.2. Antenna Construction67

Test Report Certification

Applicant : GOOD EVER TRADING LIMITED
Manufacturer : SHENZHEN CLEVER BRIGHT IMP. & EXP. Co., LTD.
EUT : True Wireless BT Earbuds
Model No. : CB-TE008, 20248, TBE-8/1751, AA-TWSSE

Measurement Procedure Used:

**FCC Rules and Regulations Part 15 Subpart C Section 15.247
ANSI C63.10: 2013**

The device described above is tested by Shenzhen Accurate Technology Co., Ltd. to determine the maximum emission levels emanating from the device. The maximum emission levels are compared to the FCC Part 15 Subpart C Section 15.247 limits. The measurement results are contained in this test report and Shenzhen Accurate Technology Co., Ltd. is assumed full responsibility for the accuracy and completeness of these measurements. Also, this report shows that the Equipment Under Test (EUT) is to be technically compliant with the FCC requirements.

This report applies to above tested sample only. This report shall not be reproduced in part without written approval of Shenzhen Accurate Technology Co., Ltd.

Date of Test : May 6-7, 2020
Date of Report : May 8, 2020

Prepared by : _____
(Bob Wang, Engineer)

Approved & Authorized Signer : _____
(Sean Liu, Manager)

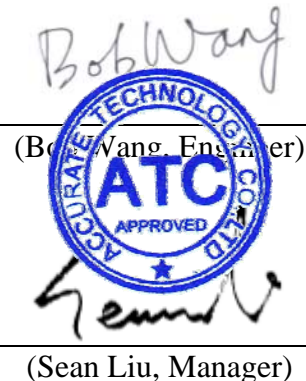

1. GENERAL INFORMATION

1.1. Description of Device (EUT)

| | | |
|--------------------|---|---|
| Model Number | : | CB-TE008, 20248, TBE-8/1751, AA-TWSSE (Note: These samples are same except their appearance is different. So we prepare CB-TE008 for test only.) |
| Bluetooth version | : | V5.0 |
| Frequency Range | : | 2402MHz-2480MHz |
| Number of Channels | : | 79 |
| Antenna Gain(Max) | : | -0.58dBi |
| Antenna type | : | PCB Antenna |
| Modulation mode | : | GFSK, $\pi/4$ DQPSK |
| Power Supply | : | DC 3.7V (Powered by Lithium battery) or DC 5.0V (Powered by USB port) |
| Applicant | : | GOOD EVER TRADING LIMITED |
| Address | : | Rm1701, Zhuoyue Building, Fuhua Yi Rd., Futian Central Zone, Shenzhen, P.R.China |
| Manufacturer | : | SHENZHEN CLEVER BRIGHT IMP. & EXP. Co., LTD. |
| Address | : | Rm1701, Zhuoyue Building, Fuhua Yi Rd., Futian Central Zone, Shenzhen, P.R.China |

1.2. Accessory and Auxiliary Equipment

| | | |
|---|---|--|
| AC/DC Power Adapter (provided by laboratory) | : | Model:BEK-QC-001 INPUT: 120V~60Hz OUTPUT:5V/1A |
|---|---|--|

1.3. Description of Test Facility

| | | |
|---------------|---|---|
| EMC Lab | : | Recognition of accreditation by Federal Communications Commission (FCC) The Designation Number is CN1189 The Registration Number is 708358 Listed by Innovation, Science and Economic Development Canada (ISED) The Registration Number is 5077A-2 Accredited by China National Accreditation Service for Conformity Assessment (CNAS) The Registration Number is CNAS L3193 Accredited by American Association for Laboratory Accreditation (A2LA) The Certificate Number is 4297.01 |
| Name of Firm | : | Shenzhen Accurate Technology Co., Ltd. |
| Site Location | : | 1/F., Building A, Changyuan New Material Port, Science & Industry Park, Nanshan District, Shenzhen, Guangdong, P.R. China |

1.4. Measurement Uncertainty

| | | |
|--|---|---------------|
| Radiated emission expanded uncertainty (9kHz-30MHz) | : | U=2.66dB, k=2 |
| Radiated emission expanded uncertainty (30MHz-1000MHz) | : | U=4.28dB, k=2 |
| Radiated emission expanded uncertainty (1G-18GHz) | : | U=4.98dB, k=2 |
| Radiated emission expanded uncertainty (18G-26.5GHz) | : | U=5.06dB, k=2 |
| Conduction Emission Expanded Uncertainty (Mains ports, 9kHz-30MHz) | : | U=2.72dB, k=2 |
| Conduction Emission Expanded Uncertainty (Telecommunication ports, 150kHz-30MHz) | : | U=2.94dB, k=2 |
| Power disturbance Expanded Uncertainty | : | U=2.92dB, k=2 |
| Harmonic current expanded uncertainty | : | U=0.512%, k=2 |

2. MEASURING DEVICE AND TEST EQUIPMENT

Table 1: List of Test and Measurement Equipment

| Kind of equipment | Manufacturer | Type | S/N | Calibrated dates | Calibrated until |
|-----------------------------|------------------------|------------------------------------|-----------|------------------|------------------|
| EMI Test Receiver | Rohde&Schwarz | ESCS30 | 100307 | Jan. 04, 2020 | 1 Year |
| EMI Test Receiver | Rohde& Schwarz | ESR | 101817 | Jan. 04, 2020 | 1 Year |
| Spectrum Analyzer | Rohde&Schwarz | FSV40 | 101495 | Jan. 04, 2020 | 1 Year |
| Pre-Amplifier | Rohde&Schwarz | CBLU1183540-01 | 3791 | Jan. 04, 2020 | 1 Year |
| Loop Antenna | Schwarzbeck | FMZB1516 | 1516131 | Jan. 04, 2020 | 1 Year |
| Bilog Antenna | Schwarzbeck | VULB9163 | 9163-323 | Jan. 04, 2020 | 1 Year |
| Horn Antenna | Schwarzbeck | BBHA9120D | 9120D-655 | Jan. 04, 2020 | 1 Year |
| Horn Antenna | Schwarzbeck | BBHA9170 | 9170-359 | Jan. 04, 2020 | 1 Year |
| LISN | Schwarzbeck | NSLK8126 | 8126431 | Jan. 04, 2020 | 1 Year |
| Highpass Filter | Wainwright Instruments | WHKX3.6/18G-10S S | N/A | Jan. 04, 2020 | 1 Year |
| Band Reject Filter | Wainwright Instruments | WRCG2400/2485-2375/2510-60/11SS | N/A | Jan. 04, 2020 | 1 Year |
| RF COAXIAL CABLE | SUHNER | N-5m(Frequency range:9KHz-26.5GHz) | NO.3 | Jan. 04, 2020 | 1 Year |
| RF COAXIAL CABLE | SUHNER | N-5m(Frequency range:9KHz-26.5GHz) | NO.4 | Jan. 04, 2020 | 1 Year |
| RF COAXIAL CABLE | SUHNER | N-1m(Frequency range:9KHz-26.5GHz) | NO.5 | Jan. 04, 2020 | 1 Year |
| RF COAXIAL CABLE | SUHNER | N-1m(Frequency range:9KHz-26.5GHz) | NO.6 | Jan. 04, 2020 | 1 Year |
| Temporary antenna connector | NTGS | 14AE | N/A | Jan. 20, 2020 | N/A |

Note: The temporary antenna connector is soldered on the PCB board in order to perform conducted tests and this temporary antenna connector is listed in the equipment list.

3. OPERATION OF EUT DURING TESTING

3.1. Operating Mode

The mode is used: Transmitting mode
Low Channel: 2402MHz
Middle Channel: 2441MHz
High Channel: 2480MHz
Hopping

3.2. Configuration and peripherals

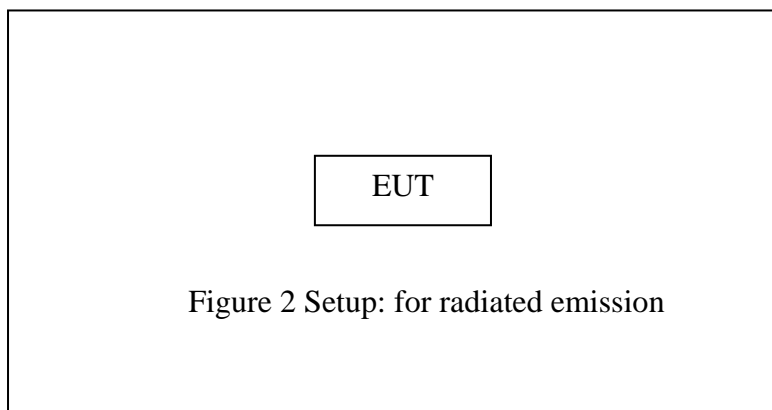
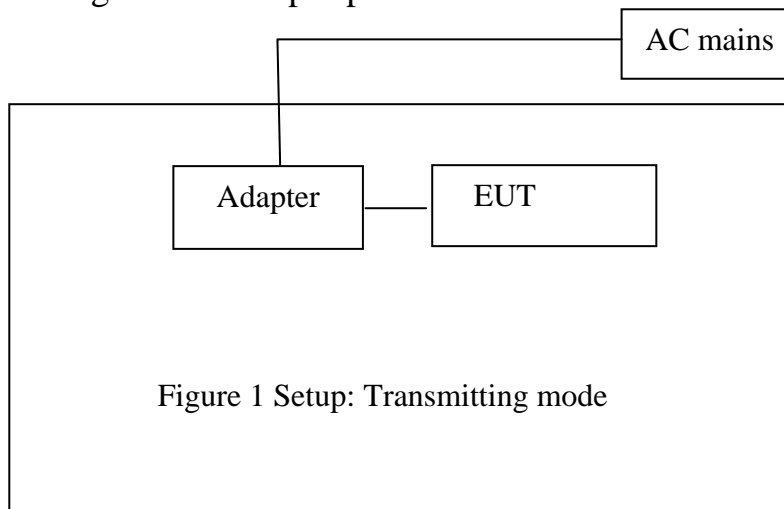

4. TEST PROCEDURES AND RESULTS

| FCC Rules | Description of Test | Result |
|-------------------------------------|--|---------------|
| Section 15.247(a)(1) | 20dB Bandwidth Test | Compliant |
| Section 15.247(a)(1) | Carrier Frequency Separation Test | Compliant |
| Section 15.247(a)(1)(iii) | Number Of Hopping Frequency Test | Compliant |
| Section 15.247(a)(1)(iii) | Dwell Time Test | Compliant |
| Section 15.247(b)(1) | Maximum Peak Output Power Test | Compliant |
| Section 15.247(d) Section 15.209 | Radiated Emission Test | Compliant |
| Section 15.247(d) | Band Edge Compliance Test | Compliant |
| Section 15.207 | AC Power Line Conducted Emissions Test | Compliant |
| Section 15.203 | Antenna Requirement | Compliant |

5. 20DB BANDWIDTH TEST

5.1. Block Diagram of Test Setup

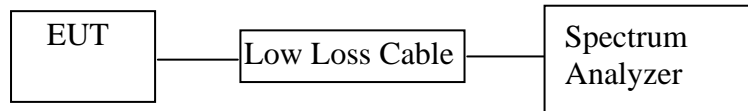

5.2. The Requirement For Section 15.247(a)(1)

Section 15.247(a)(1): Frequency hopping systems shall have hopping channel carrier frequencies separated by a minimum of 25 kHz or the 20 dB bandwidth of the hopping channel, whichever is greater.

5.3. EUT Configuration on Measurement

The equipment are installed on the emission measurement to meet the commission requirements and operating regulations in a manner which tends to maximize its emission characteristics in normal application.

5.4. Operating Condition of EUT

5.4.1. Setup the EUT and simulator as shown as Section 5.1.

5.4.2. Turn on the power of all equipment.

5.4.3. Let the EUT work in TX (Hopping off) modes measure it. The transmit frequency are 2402-2480MHz. We select 2402MHz, 2441MHz, and 2480MHz TX frequency to transmit.

5.5. Test Procedure

5.5.1. The transmitter output was connected to the spectrum analyzer through a low loss cable.

5.5.2. Set RBW of spectrum analyzer to 30 kHz and VBW to 100 kHz.

5.5.3. The 20dB bandwidth is defined as the total spectrum the power of which is higher than peak power minus 20dB.

5.6. Test Result

Test Lab: Shielding room

| Channel | Frequency (MHz) | GFSK 20dB Bandwidth (MHz) | Π/4-DQPSK 20dB Bandwidth (MHz) | Result |
|---------|-----------------|---------------------------|--------------------------------|--------|
| Low | 2402 | 0.7467 | 1.2069 | Pass |
| Middle | 2441 | 0.7467 | 1.2069 | Pass |
| High | 2480 | 0.7467 | 1.2069 | Pass |

The spectrum analyzer plots are attached as below.

GFSK Mode

Low channel

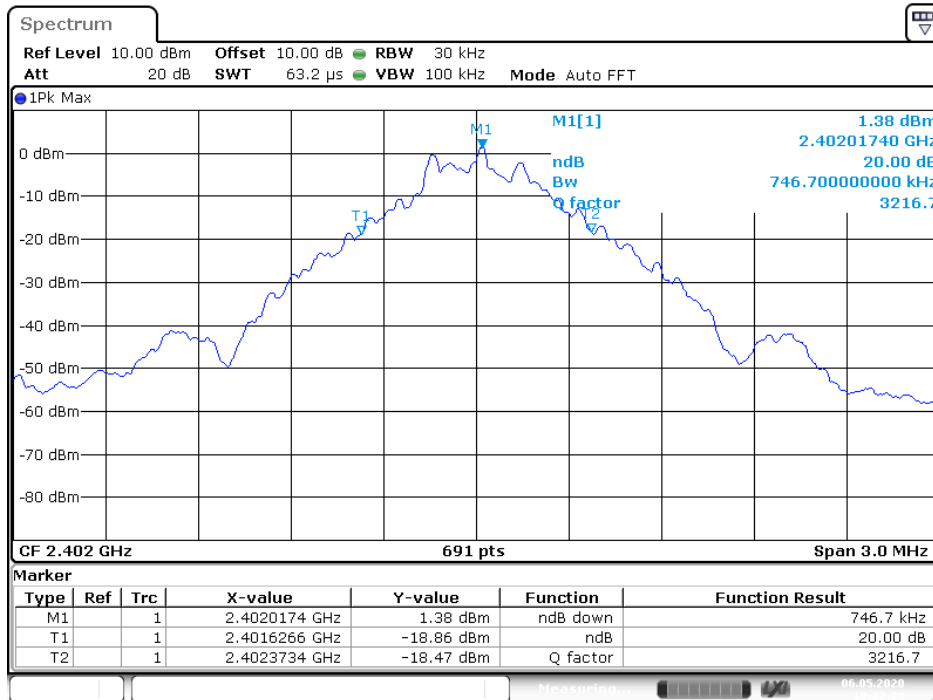

Date: 6.MAY.2020 18:22:00

Middle channel

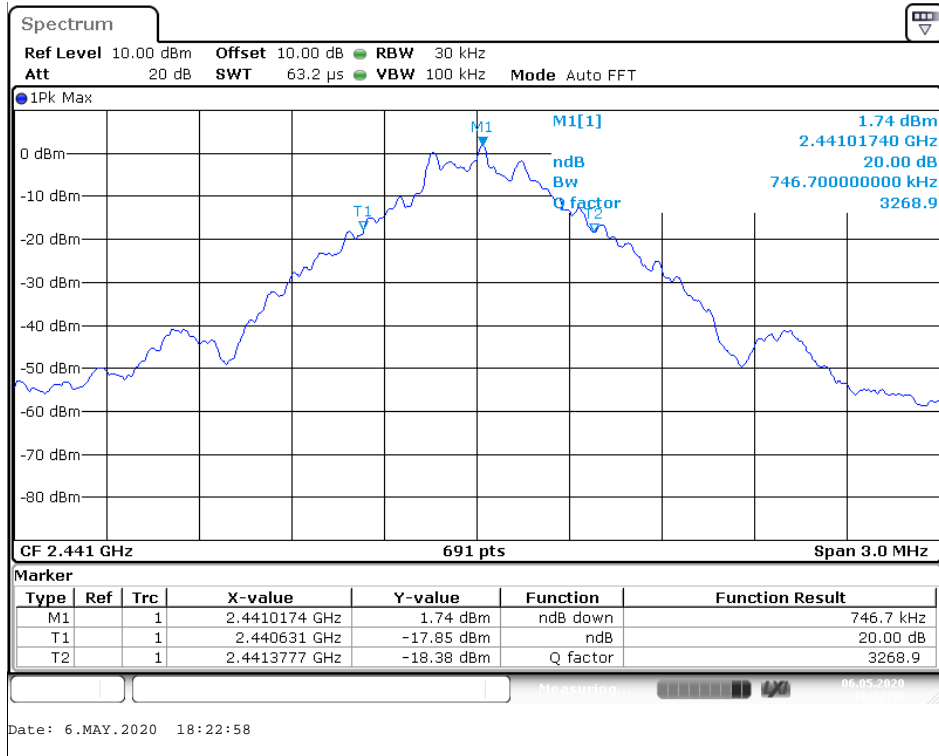

High channel

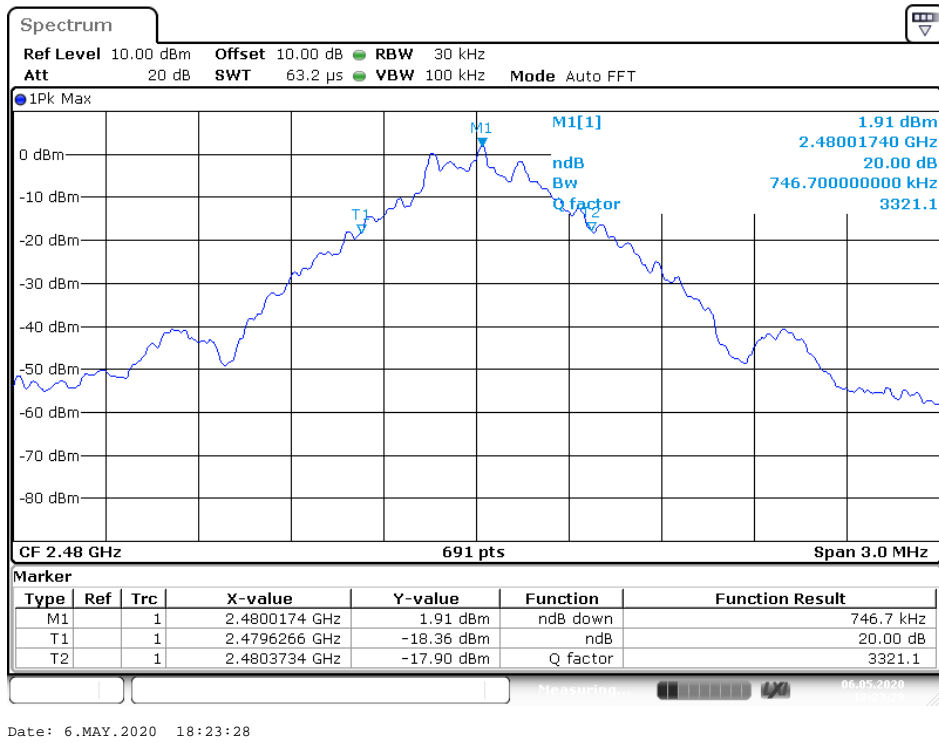

Π/4-DQPSK Mode

Low channel

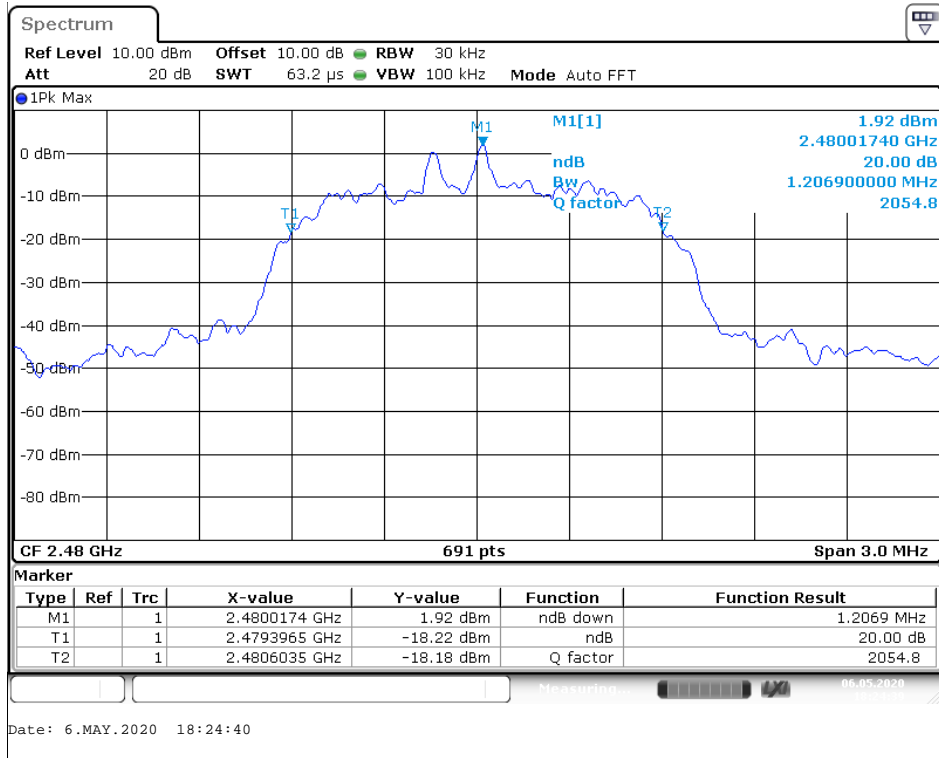

Middle channel

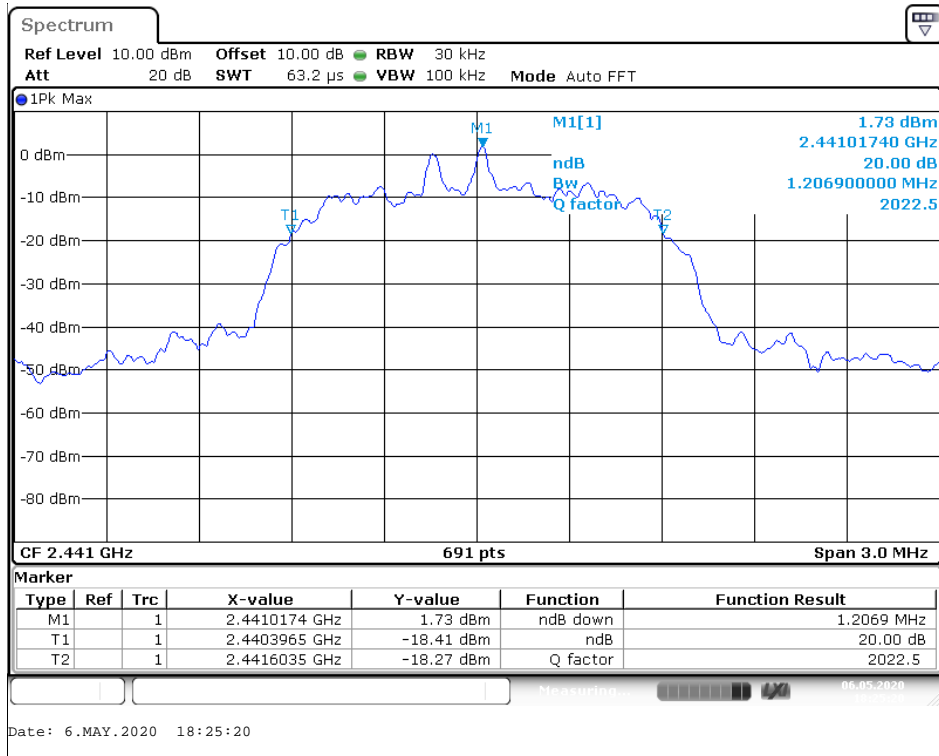

High channel

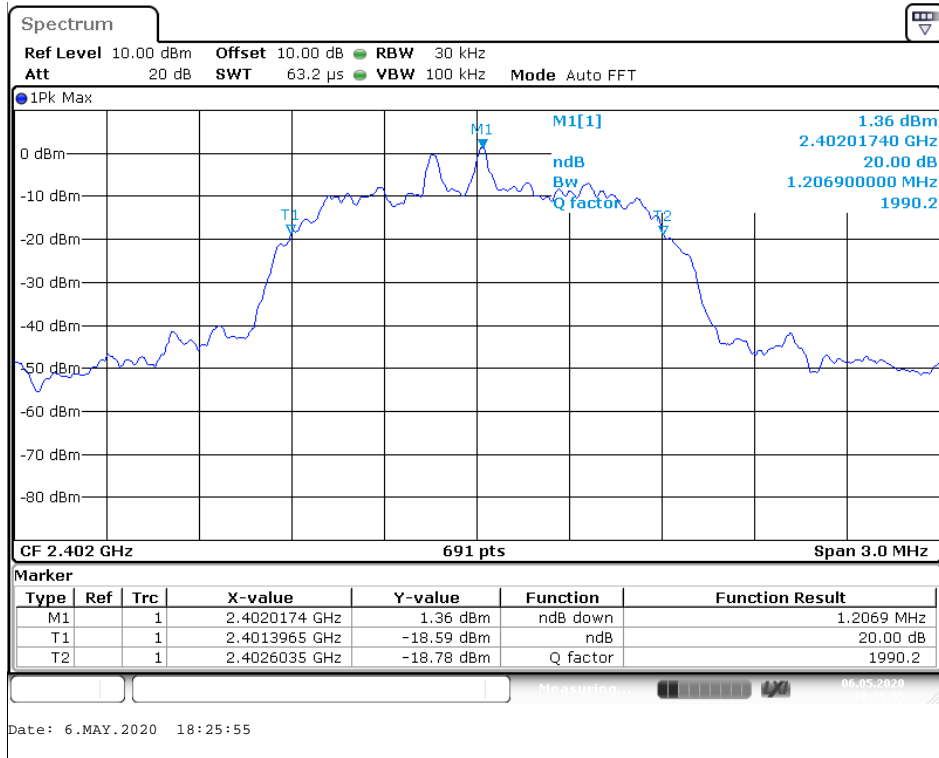

6. CARRIER FREQUENCY SEPARATION TEST

6.1. Block Diagram of Test Setup

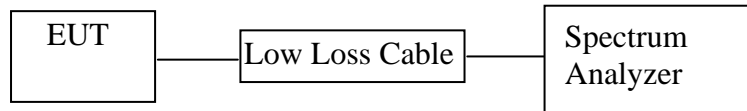

6.2. The Requirement For Section 15.247(a)(1)

Section 15.247(a)(1): Frequency hopping systems shall have hopping channel carrier frequencies separated by a minimum of 25 kHz or the 20 dB bandwidth of the hopping channel, whichever is greater. Alternatively, frequency hopping systems operating in the 2400-2483.5 MHz band may have hopping channel carrier frequencies that are separated by 25 kHz or two-thirds of the 20 dB bandwidth of the hopping channel, whichever is greater, provided the systems operate with an output power no greater than 125 mW. The system shall hop to channel frequencies that are selected at the system hopping rate from a pseudo randomly ordered list of hopping frequencies. Each frequency must be used equally on the average by each transmitter. The system receivers shall have input bandwidths that match the hopping channel bandwidths of their corresponding transmitters and shall shift frequencies in synchronization with the transmitted signals.

6.3. EUT Configuration on Measurement

The equipment are installed on the emission measurement to meet the commission requirements and operating regulations in a manner which tends to maximize its emission characteristics in normal application.

6.4. Operating Condition of EUT

6.4.1. Setup the EUT and simulator as shown as Section 6.1.

6.4.2. Turn on the power of all equipment.

6.4.3. Let the EUT work in TX (Hopping on) modes measure it. The transmit frequency are 2402-2480MHz. We select 2402MHz, 2441MHz, and 2480MHz TX frequency to transmit.

6.5. Test Procedure

6.5.1. The transmitter output was connected to the spectrum analyzer through a low loss cable.

6.5.2. Set RBW of spectrum analyzer to 30 kHz and VBW to 100 kHz. Adjust Span to 3 MHz.

6.5.3. Set the adjacent channel of the EUT Maxhold another trace.

6.5.4. Measurement the channel separation

6.6. Test Result

Test Lab: Shielding room

GFSK

| Channel | Frequency (MHz) | Channel Separation(MHz) | Limit (MHz) | Result |
|---------|-----------------|-------------------------|-----------------------------|--------|
| Low | 2402 | 1.0029 | 25KHz or 2/3*20dB bandwidth | Pass |
| | 2403 | | | |
| Middle | 2440 | 1.0029 | 25KHz or 2/3*20dB bandwidth | Pass |
| | 2441 | | | |
| High | 2479 | 1.0029 | 25KHz or 2/3*20dB bandwidth | Pass |
| | 2480 | | | |

Π/4-DQPSK

| Channel | Frequency (MHz) | Channel Separation(MHz) | Limit (MHz) | Result |
|---------|-----------------|-------------------------|-----------------------------|--------|
| Low | 2402 | 1.0029 | 25KHz or 2/3*20dB bandwidth | Pass |
| | 2403 | | | |
| Middle | 2440 | 1.0029 | 25KHz or 2/3*20dB bandwidth | Pass |
| | 2441 | | | |
| High | 2479 | 1.0029 | 25KHz or 2/3*20dB bandwidth | Pass |
| | 2480 | | | |

GFSK Mode

Low channel

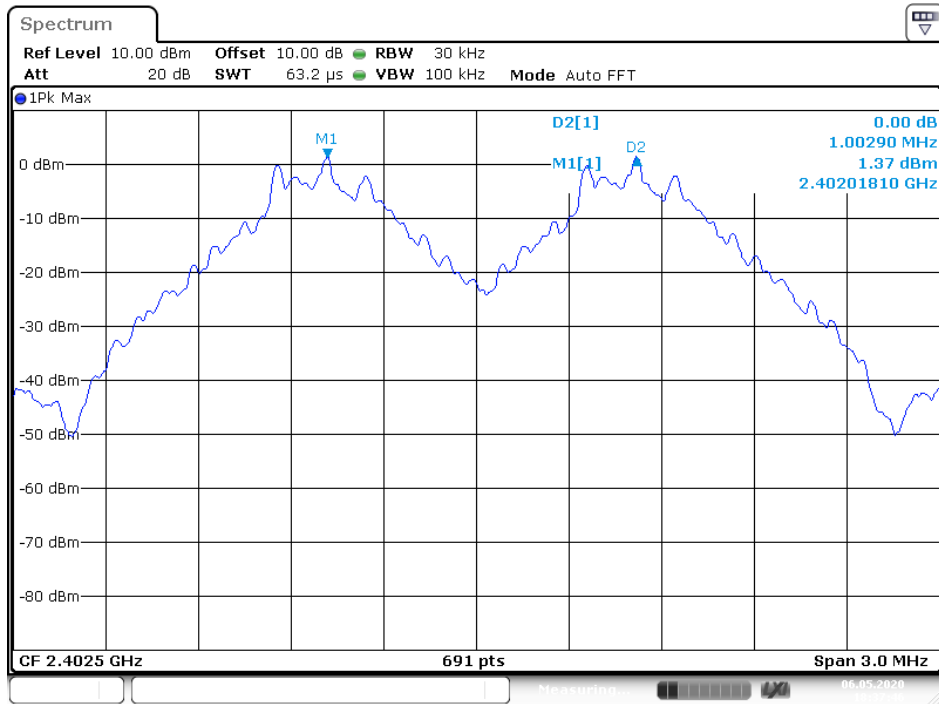

Middle channel

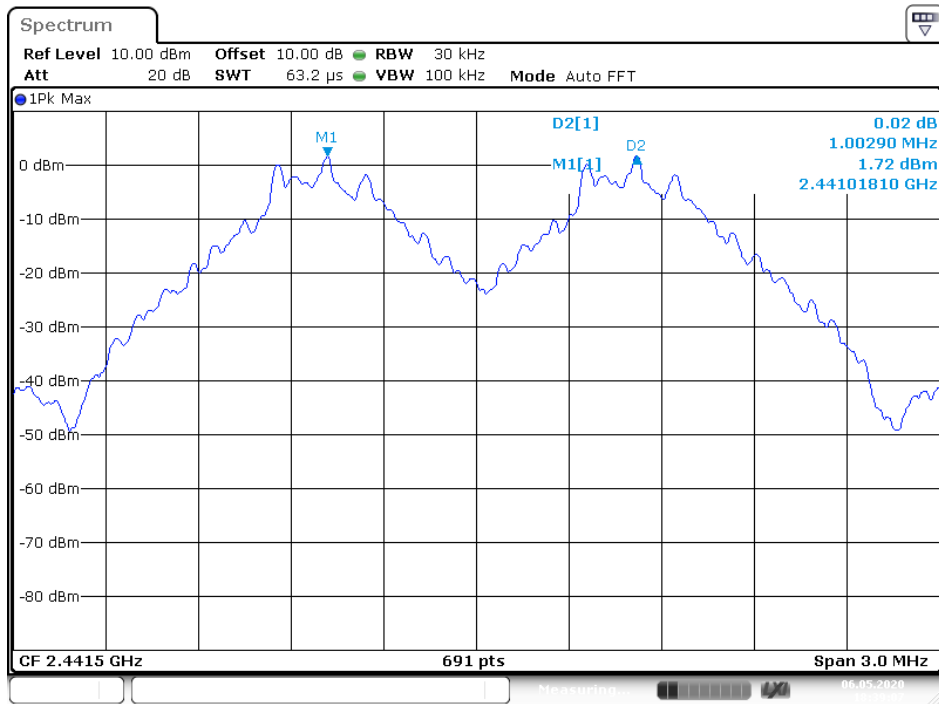

High channel

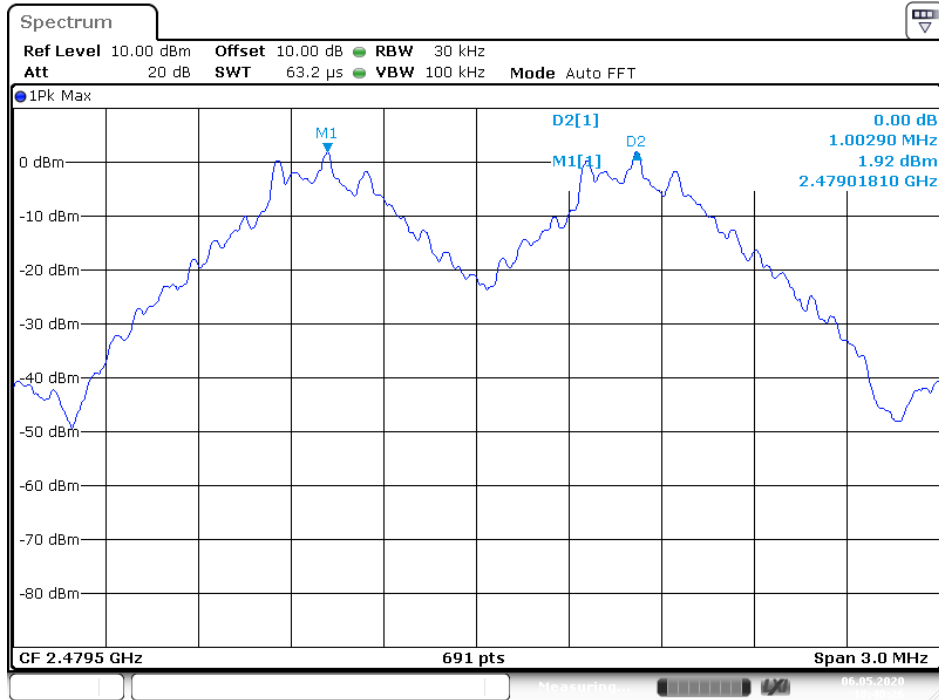

Π/4-DQPSK Mode

Low channel

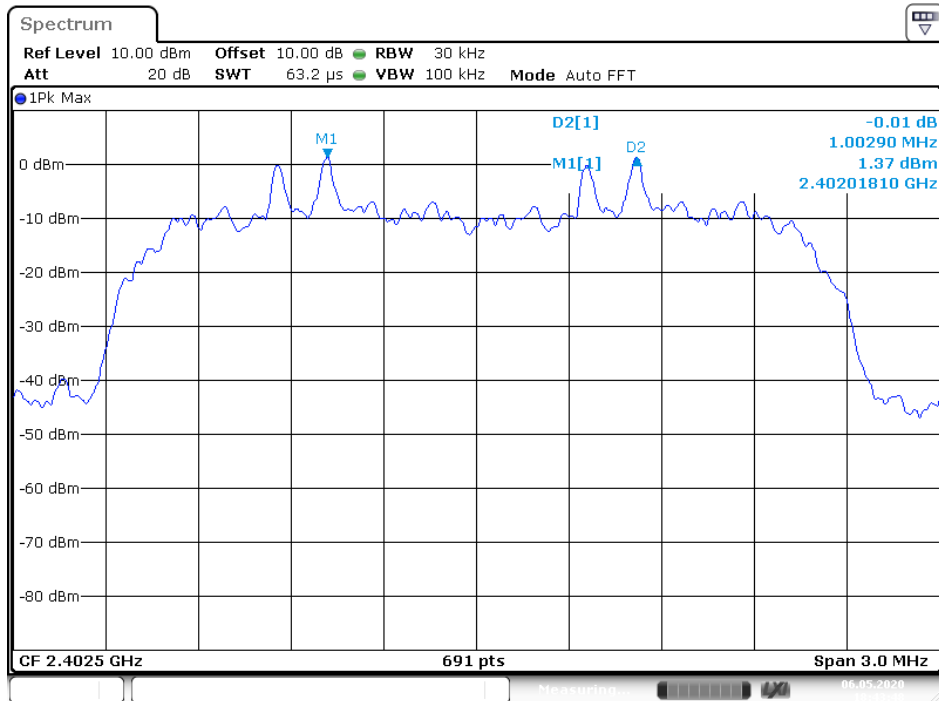

Middle channel

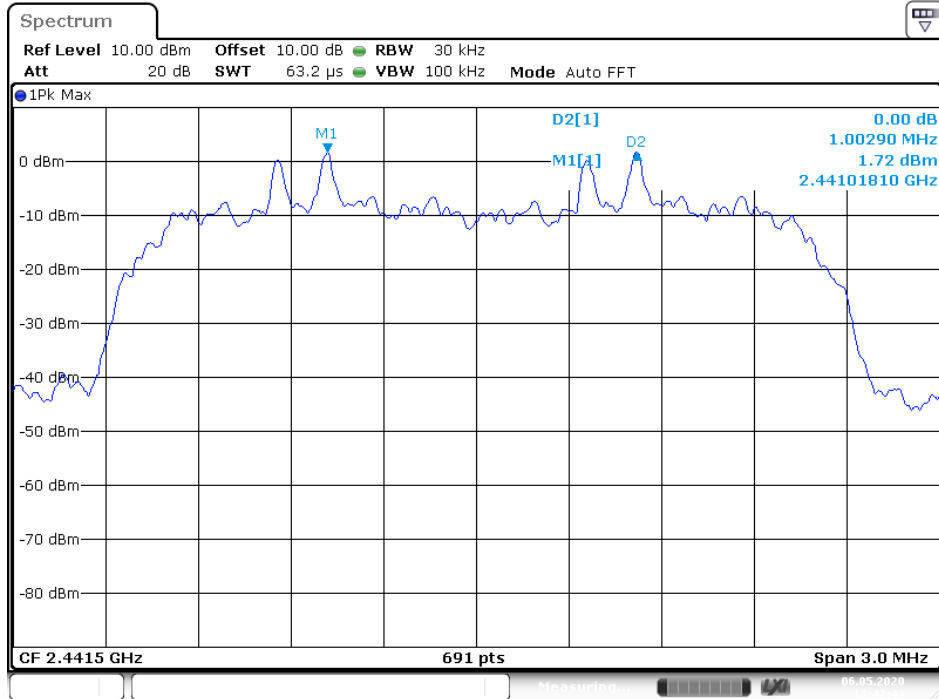

High channel

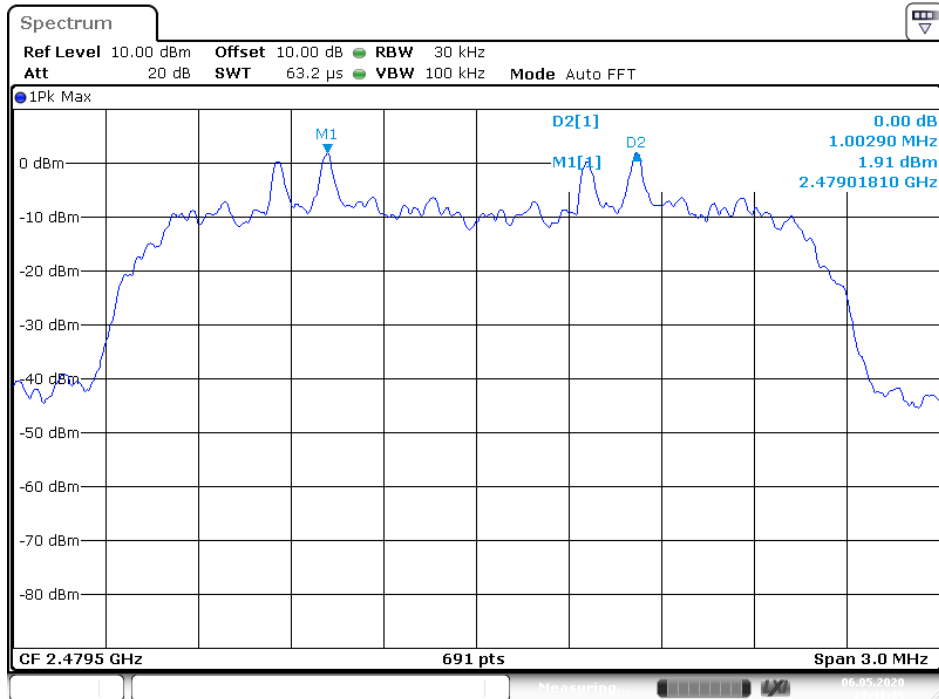

7. NUMBER OF HOPPING FREQUENCY TEST

7.1. Block Diagram of Test Setup

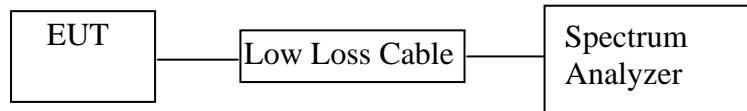

7.2. The Requirement For Section 15.247(a)(1)(iii)

Section 15.247(a)(1)(iii): Frequency hopping systems in the 2400-2483.5 MHz band shall use at least 15 channels.

7.3. EUT Configuration on Measurement

The equipment are installed on the emission measurement to meet the commission requirements and operating regulations in a manner which tends to maximize its emission characteristics in normal application.

7.4. Operating Condition of EUT

7.4.1. Setup the EUT and simulator as shown as Section 7.1.

7.4.2. Turn on the power of all equipment.

7.4.3. Let the EUT work in TX (Hopping on) modes measure it.

7.5. Test Procedure

7.5.1. The transmitter output was connected to the spectrum analyzer through a low loss cable.

7.5.2. Set the spectrum analyzer as RBW=100 kHz, VBW=300 kHz.

7.5.3. Max hold, view and count how many channel in the band.

7.6. Test Result

Test Lab: Shielding room

| Total number of hopping channel | Measurement result(CH) | Limit(CH) | Result |
|---------------------------------|------------------------|-----------|--------|
| | 79 | ≥ 15 | Pass |

The spectrum analyzer plots are attached as below.

Number of hopping channels (GFSK Mode)

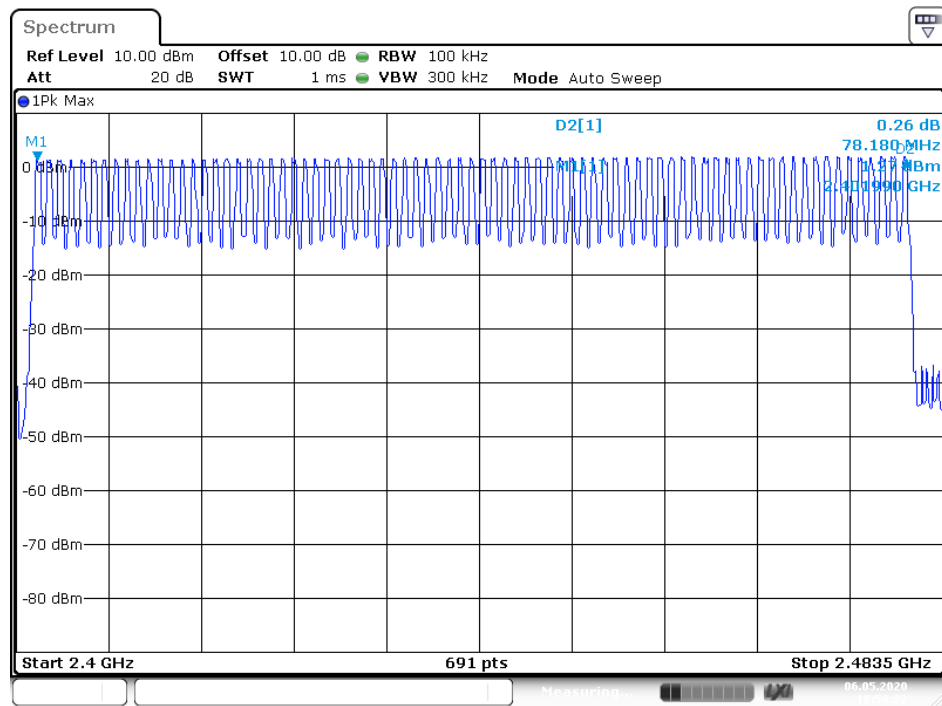

Date: 6.MAY.2020 18:50:22

Number of hopping channels ($\Pi/4$ -DQPSK Mode)

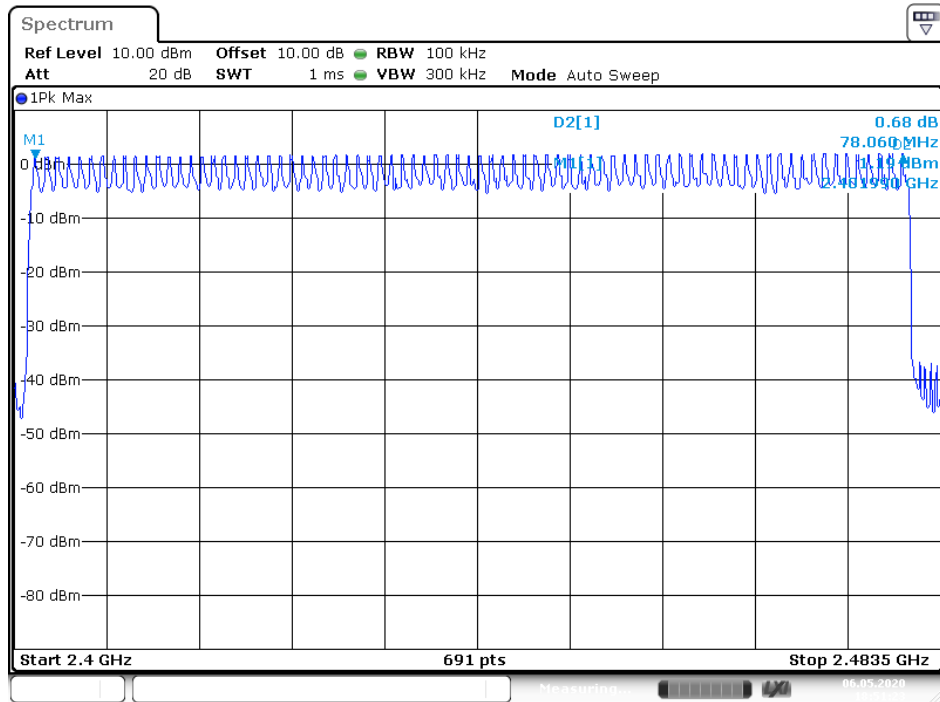

8. DWELL TIME TEST

8.1. Block Diagram of Test Setup

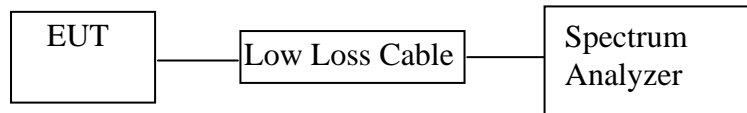

8.2. The Requirement For Section 15.247(a)(1)(iii)

Section 15.247(a)(1)(iii): Frequency hopping systems in the 2400-2483.5 MHz band shall use at least 15 channels. The average time of occupancy on any channel shall not be greater than 0.4 seconds within a period of 0.4 seconds multiplied by the number of hopping channels employed. Frequency hopping systems may avoid or suppress transmissions on a particular hopping frequency provided that a minimum of 15 channels are used.

8.3. EUT Configuration on Measurement

The equipment are installed on the emission measurement to meet the commission requirements and operating regulations in a manner which tends to maximize its emission characteristics in normal application.

8.4. Operating Condition of EUT

8.4.1. Setup the EUT and simulator as shown as Section 8.1.

8.4.2. Turn on the power of all equipment.

8.4.3. Let the EUT work in TX (Hopping on) modes measure it. The transmit frequency are 2402-2480MHz. We select 2402MHz, 2441MHz, and 2480MHz TX frequency to transmit.

8.5. Test Procedure

8.5.1. The transmitter output was connected to the spectrum analyzer through a low loss cable.

8.5.2. Set center frequency of spectrum analyzer = operating frequency.

8.5.3. Set the spectrum analyzer as RBW=1MHz, VBW=3MHz, Span=0Hz, Adjust Sweep=5ms, 10ms, 15ms. Get the pulse time.

8.5.4. Repeat above procedures until all frequency measured were complete.

8.6. Test Result

Test Lab: Shielding room

GFSK Mode (Worse case)

| Mode | Channel Frequency (MHz) | Pulse Time (ms) | Dwell Time (ms) | Limit (ms) |
|--|-------------------------|-----------------|-----------------|------------|
| DH1 | 2441 | 0.442 | 141.44 | 400 |
| A period transmit time = $0.4 \times 79 = 31.6$ Dwell time = pulse time $\times (1600/(2*79)) \times 31.6$ | | | | |
| DH3 | 2441 | 1.710 | 273.60 | 400 |
| A period transmit time = $0.4 \times 79 = 31.6$ Dwell time = pulse time $\times (1600/(4*79)) \times 31.6$ | | | | |
| DH5 | 2441 | 2.978 | 317.65 | 400 |
| A period transmit time = $0.4 \times 79 = 31.6$ Dwell time = pulse time $\times (1600/(6*79)) \times 31.6$ | | | | |

$\Pi/4$ -DQPSK (Worse case)

| Mode | Channel Frequency (MHz) | Pulse Time (ms) | Dwell Time (ms) | Limit (ms) |
|--|-------------------------|-----------------|-----------------|------------|
| DH1 | 2441 | 0.449 | 143.68 | 400 |
| A period transmit time = $0.4 \times 79 = 31.6$ Dwell time = pulse time $\times (1600/(2*79)) \times 31.6$ | | | | |
| DH3 | 2441 | 1.725 | 276.00 | 400 |
| A period transmit time = $0.4 \times 79 = 31.6$ Dwell time = pulse time $\times (1600/(4*79)) \times 31.6$ | | | | |
| DH5 | 2441 | 2.978 | 317.65 | 400 |
| A period transmit time = $0.4 \times 79 = 31.6$ Dwell time = pulse time $\times (1600/(6*79)) \times 31.6$ | | | | |

Note: We tested GFSK mode and $\Pi/4$ -DQPSK mode the low, middle and high channel and recorded the Worse case data for all test mode.

The spectrum analyzer plots are attached as below.

GFSK Mode

DH1 Middle channel

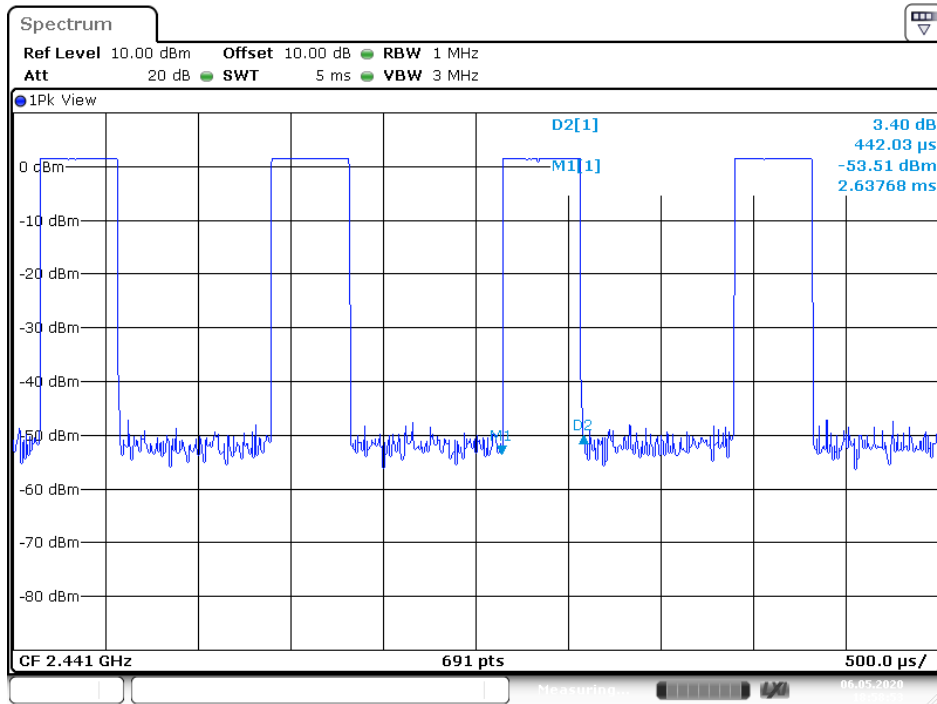

DH3 Middle channel

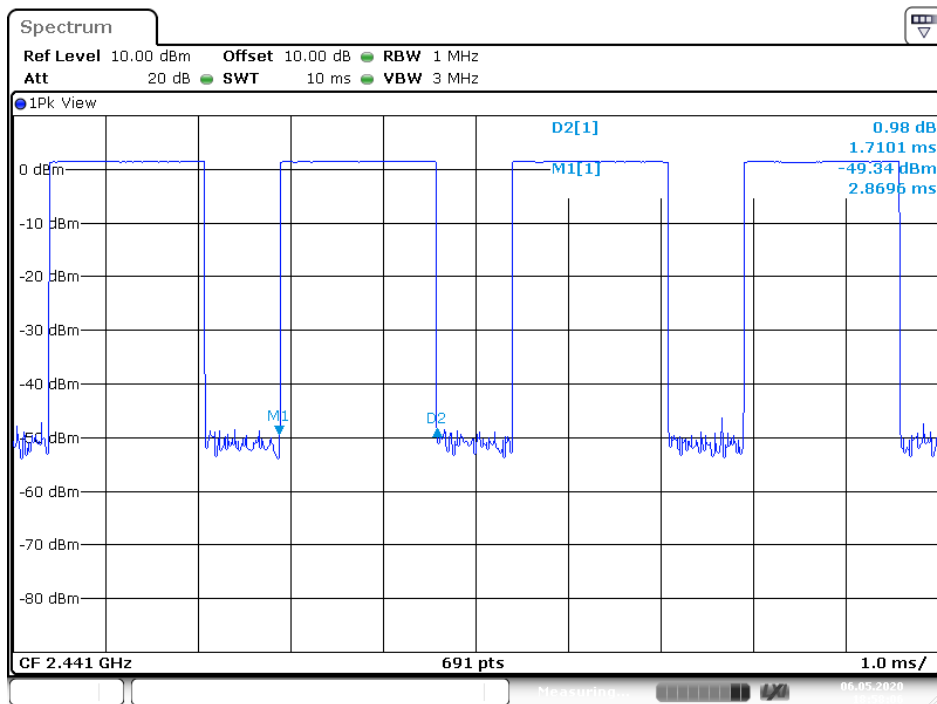

DH5 Middle channel

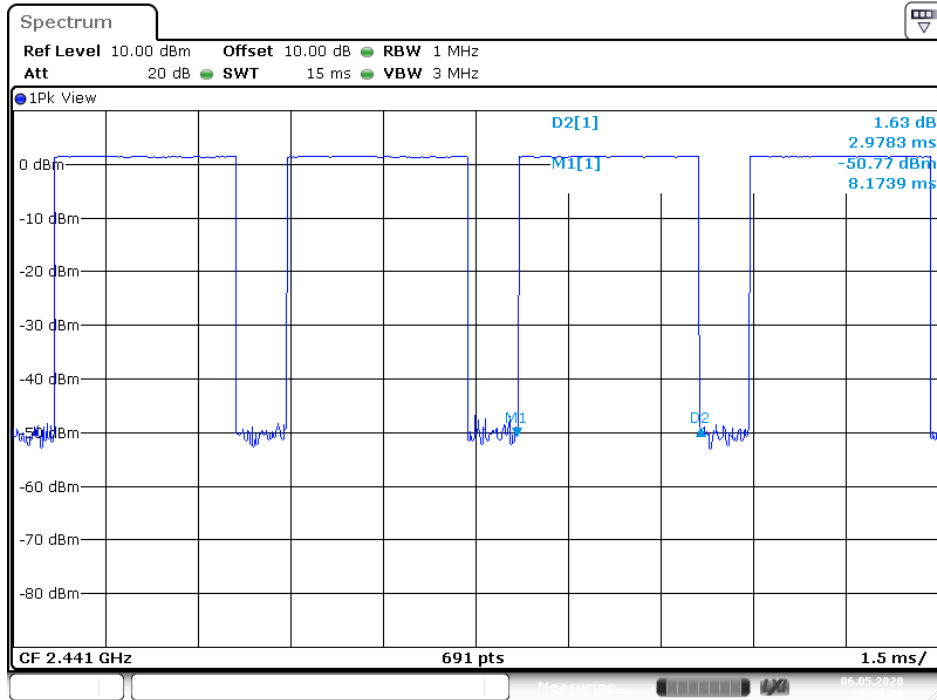

Π/4-DQPSK Mode

2DH1 Middle channel

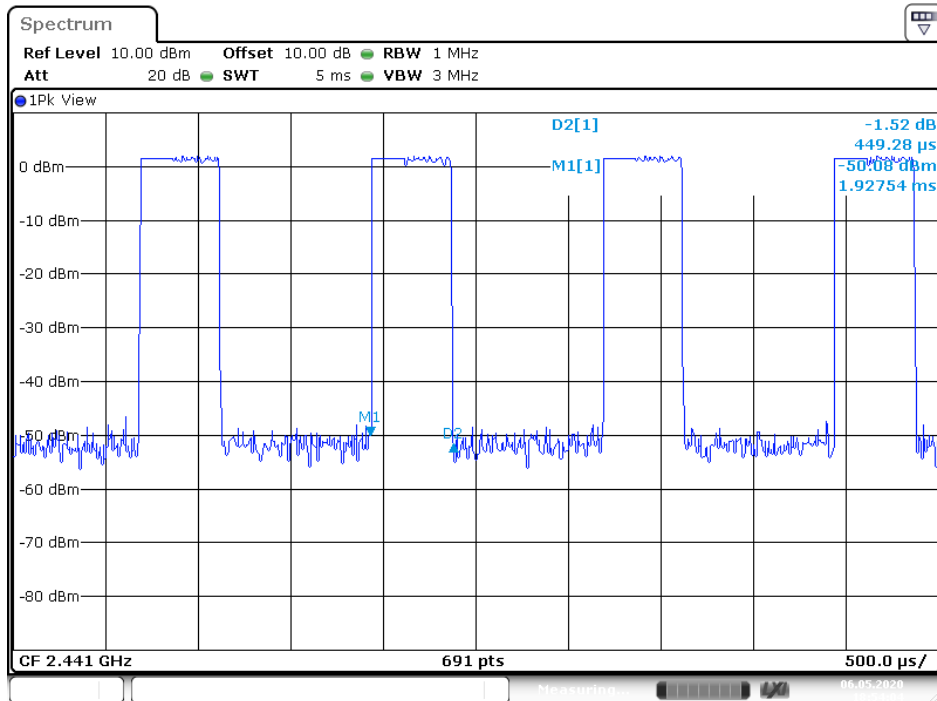

2DH3 Middle channel

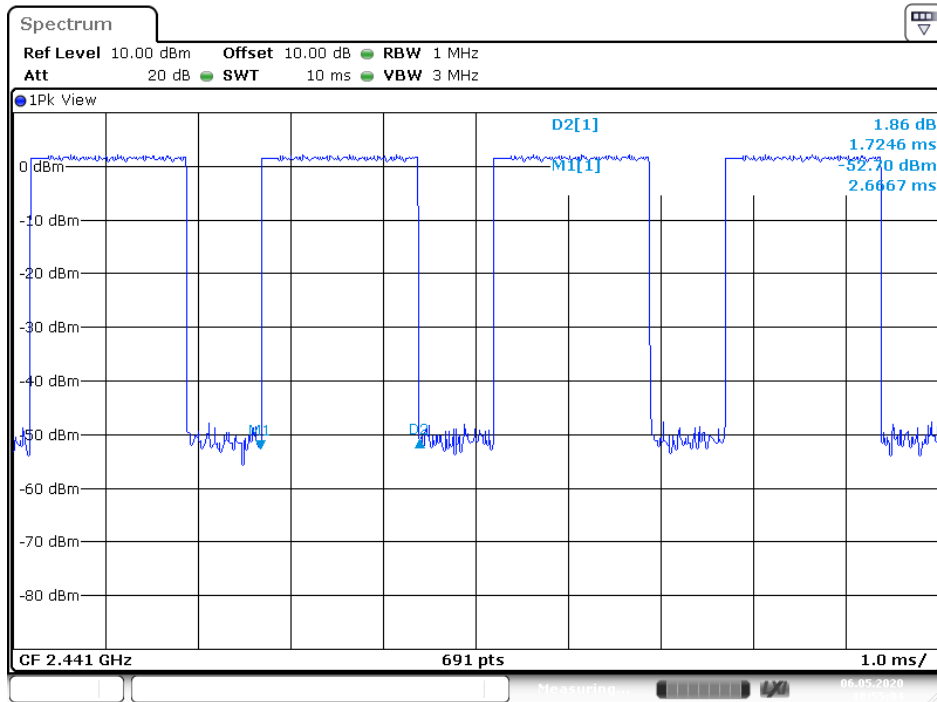

2DH5 Middle channel

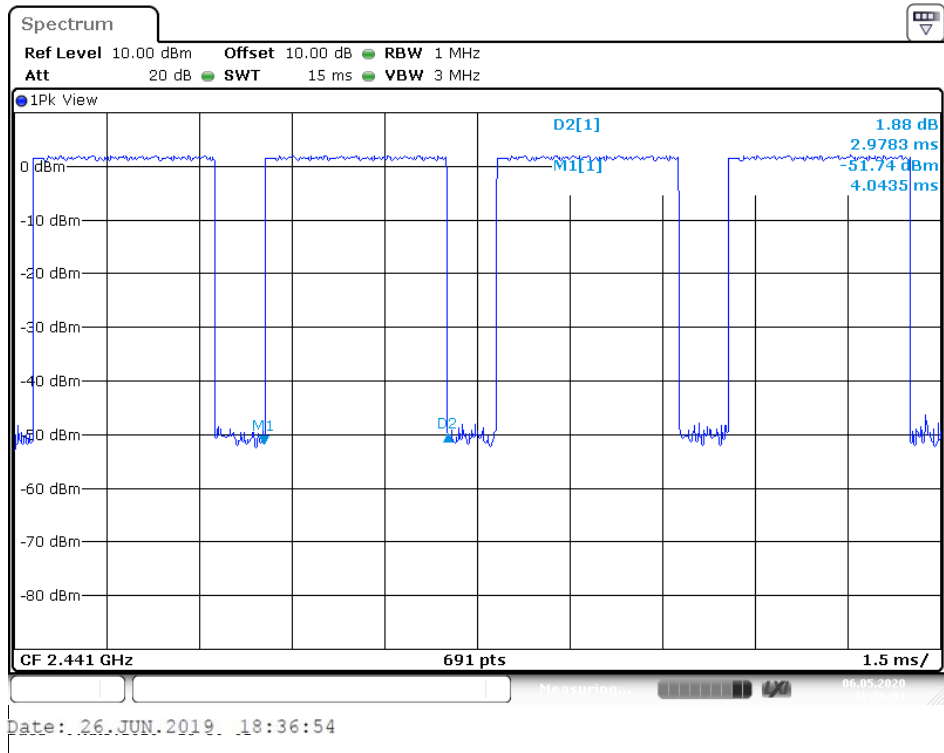

9. MAXIMUM PEAK OUTPUT POWER TEST

9.1. Block Diagram of Test Setup

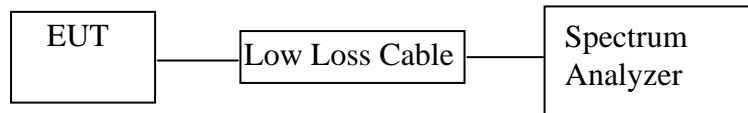

9.2. The Requirement For Section 15.247(b)(1)

Section 15.247(b)(1): For frequency hopping systems operating in the 2400-2483.5 MHz band employing at least 75 non-overlapping hopping channels, and all frequency hopping systems in the 5725-5850 MHz band: 1 watt. For all other frequency hopping systems in the 2400-2483.5 MHz band: 0.125 watts.

9.3. EUT Configuration on Measurement

The equipment are installed on the emission Measurement to meet the commission requirements and operating regulations in a manner which tends to maximize its emission characteristics in normal application.

9.4. Operating Condition of EUT

9.4.1. Setup the EUT and simulator as shown as Section 9.1.

9.4.2. Turn on the power of all equipment.

9.4.3. Let the EUT work in TX (Hopping off) modes measure it. The transmit frequency are 2402-2480MHz. We select 2402MHz, 2441MHz, and 2480MHz TX frequency to transmit.

9.5. Test Procedure

9.5.1. The transmitter output was connected to the spectrum analyzer through a low loss cable.

9.5.2. Set RBW of spectrum analyzer to 1MHz and VBW to 3MHz & 3MHz and VBW to 10MHz.

9.5.3. Measurement the maximum peak output power.

9.6. Test Result

Test Lab: Shielding room

GFSK Mode

| Channel | Frequency (MHz) | Peak Output Power (dBm/W) | Limits dBm / W |
|---------|-----------------|---------------------------|----------------|
| Low | 2402 | 1.51/0.0014 | 21 / 0.125 |
| Middle | 2441 | 1.85/0.0015 | 21 / 0.125 |
| High | 2480 | 2.08/0.0016 | 21 / 0.125 |

Π/4-DQPSK Mode

| Channel | Frequency (MHz) | Peak Output Power (dBm/W) | Limits dBm / W |
|---------|-----------------|---------------------------|----------------|
| Low | 2402 | 2.34/0.0017 | 21 / 0.125 |
| Middle | 2441 | 2.69/0.0019 | 21 / 0.125 |
| High | 2480 | 2.84/0.0019 | 21 / 0.125 |

The spectrum analyzer plots are attached as below.

GFSK Mode

Low channel

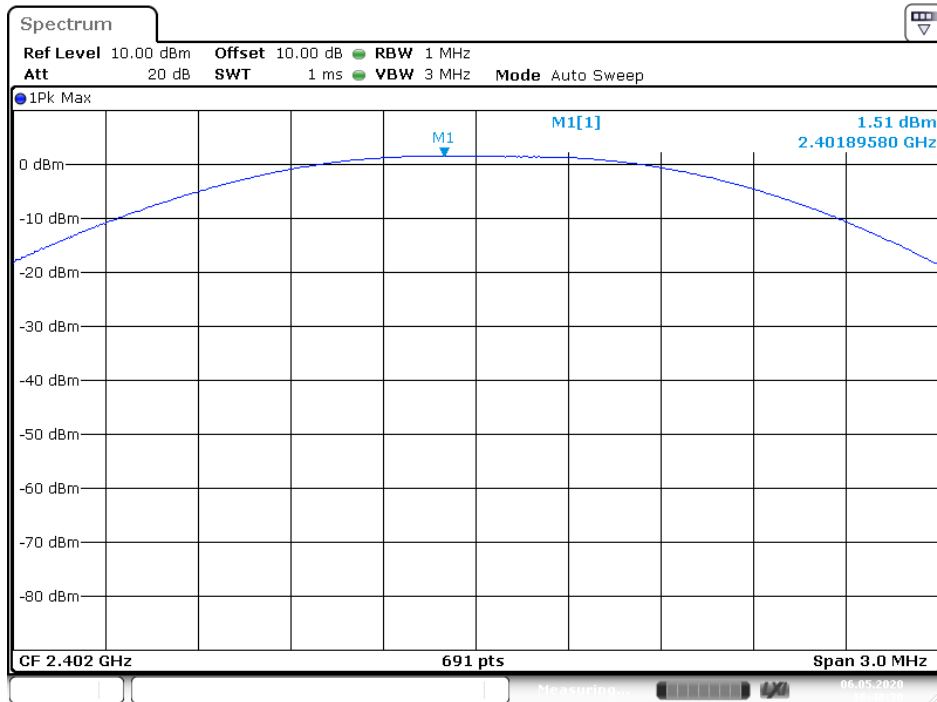

Date: 6.MAY.2020 18:48:31

Middle channel

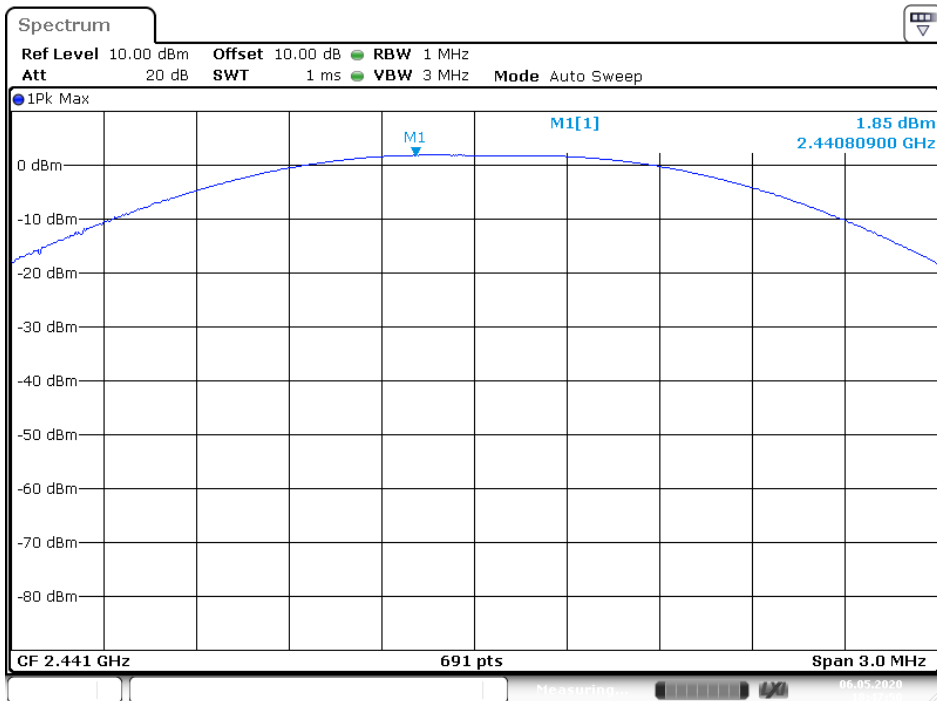

Date: 6.MAY.2020 18:47:51

High channel

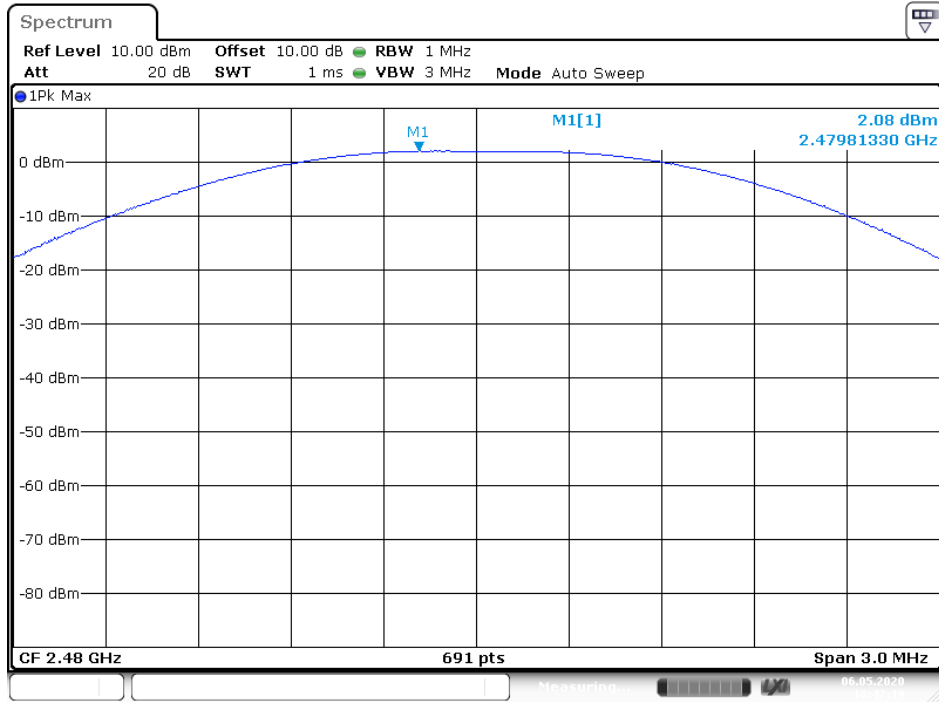

II/4-DQPSK Mode

Low channel

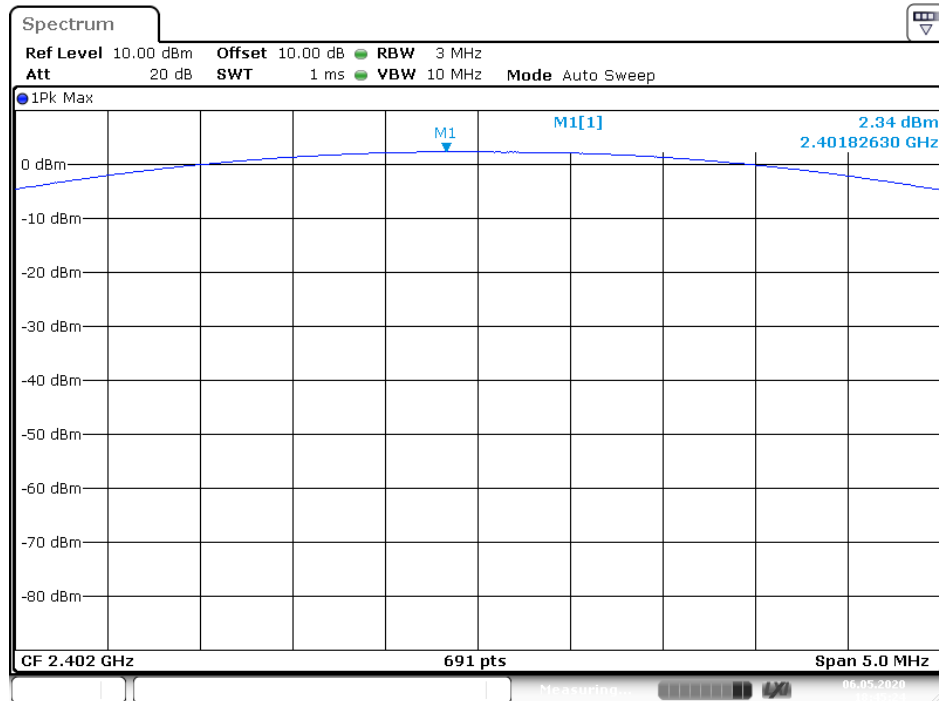

Middle channel

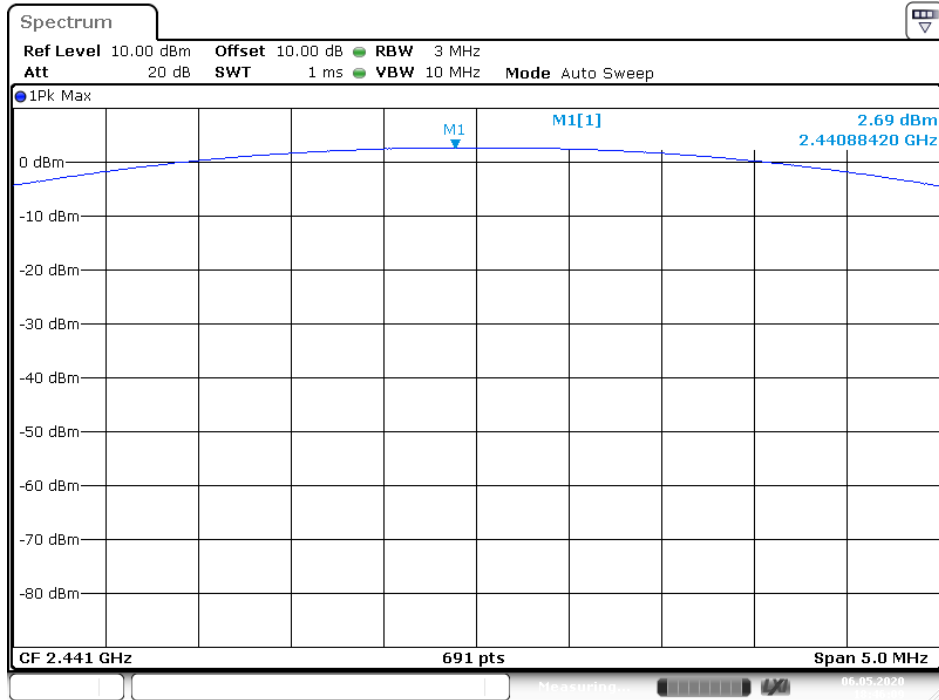

High channel

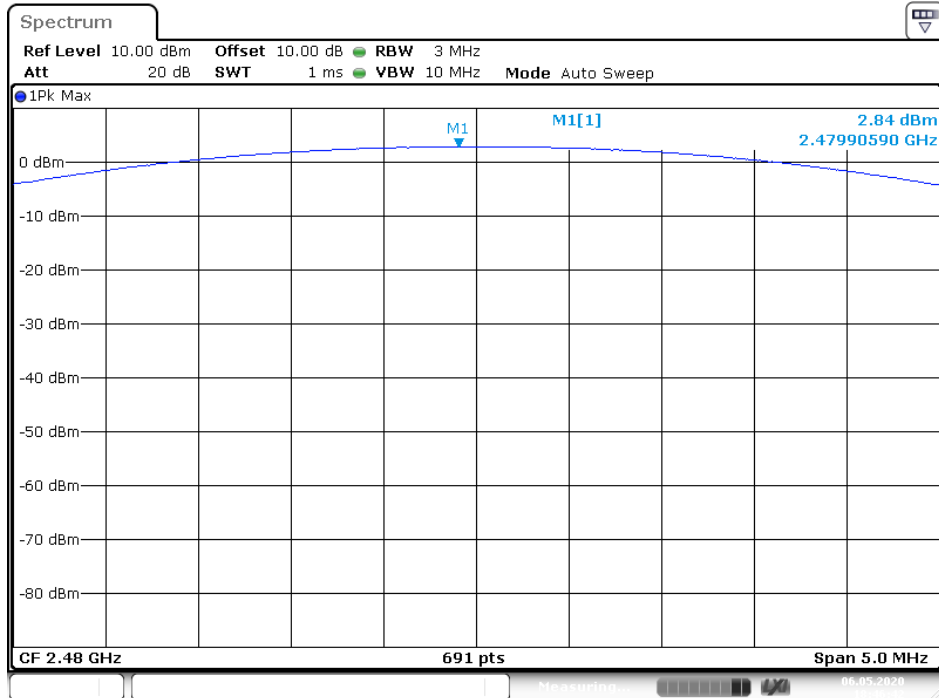

10. RADIATED EMISSION TEST

10.1. Block Diagram of Test Setup

10.1.1. Block diagram of connection between the EUT and peripherals

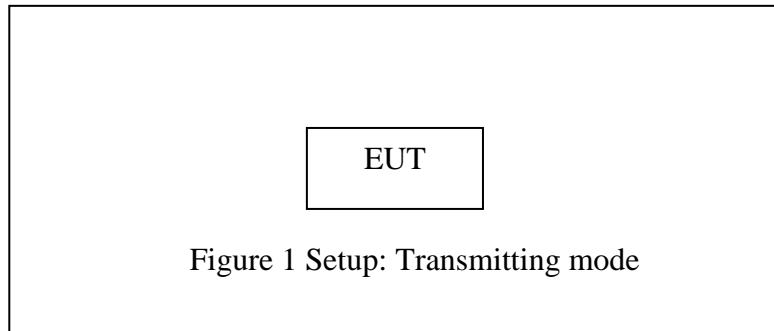

10.1.2. Semi-Anechoic Chamber Test Setup Diagram

(A) Radiated Emission Test Set-Up. Frequency below 30MHz

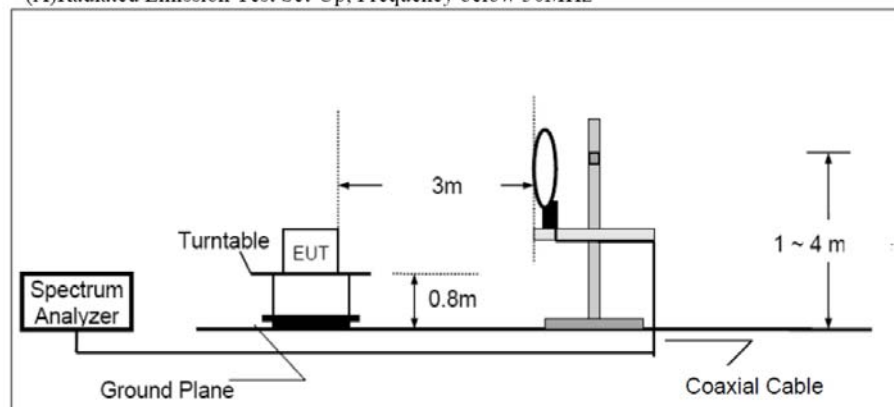

(B) Radiated Emission Test Set-Up, Frequency 30MHz-1GHz

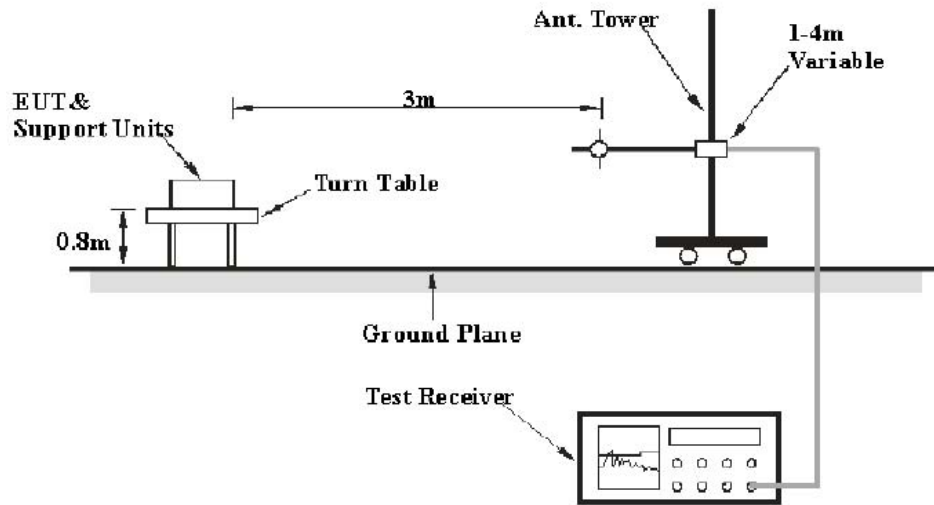

(C) Radiated Emission Test Set-Up, Frequency above 1GHz

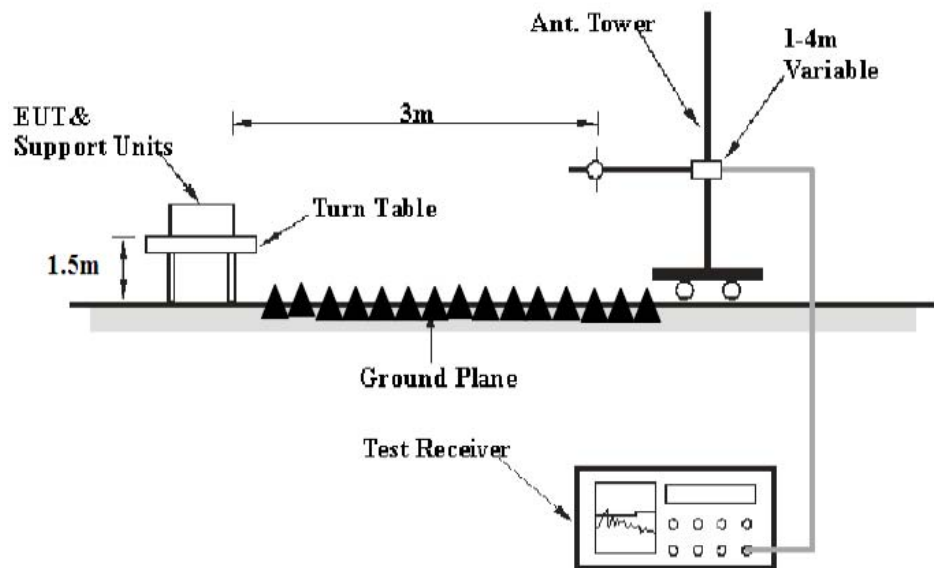

10.2. The Limit For Section 15.247(d)

Section 15.247(d): In any 100 kHz bandwidth outside the frequency band in which the spread spectrum or digitally modulated intentional radiator is operating, the radio frequency power that is produced by the intentional radiator shall be at least 20 dB below that in the 100 kHz bandwidth within the band that contains the highest level of the desired power, based on either an RF conducted or a radiated measurement, provided the transmitter demonstrates compliance with the peak conducted power limits. If the transmitter complies with the conducted power limits based on the use of RMS averaging over a time interval, as permitted under paragraph (b)(3) of this section, the attenuation required under this paragraph shall be 30 dB instead of 20 dB. Attenuation below the

general limits specified in Section 15.209(a) is not required. In addition, radiated emissions which fall in the restricted bands, as defined in Section 15.205(a), must also comply with the radiated emission limits specified in Section 15.209(a).

10.3.Restricted bands of operation

10.3.1.FCC Part 15.205 Restricted bands of operation

(a) Except as shown in paragraph (d) of this section, Only spurious emissions are permitted in any of the frequency bands listed below:

| MHz | MHz | MHz | GHz |
|--------------------------|---------------------|---------------|------------------|
| 0.090-0.110 | 16.42-16.423 | 399.9-410 | 4.5-5.15 |
| ¹ 0.495-0.505 | 16.69475-16.69525 | 608-614 | 5.35-5.46 |
| 2.1735-2.1905 | 16.80425-16.80475 | 960-1240 | 7.25-7.75 |
| 4.125-4.128 | 25.5-25.67 | 1300-1427 | 8.025-8.5 |
| 4.17725-4.17775 | 37.5-38.25 | 1435-1626.5 | 9.0-9.2 |
| 4.20725-4.20775 | 73-74.6 | 1645.5-1646.5 | 9.3-9.5 |
| 6.215-6.218 | 74.8-75.2 | 1660-1710 | 10.6-12.7 |
| 6.26775-6.26825 | 108-121.94 | 1718.8-1722.2 | 13.25-13.4 |
| 6.31175-6.31225 | 123-138 | 2200-2300 | 14.47-14.5 |
| 8.291-8.294 | 149.9-150.05 | 2310-2390 | 15.35-16.2 |
| 8.362-8.366 | 156.52475-156.52525 | 2483.5-2500 | 17.7-21.4 |
| 8.37625-8.38675 | 156.7-156.9 | 2690-2900 | 22.01-23.12 |
| 8.41425-8.41475 | 162.0125-167.17 | 3260-3267 | 23.6-24.0 |
| 12.29-12.293 | 167.72-173.2 | 3332-3339 | 31.2-31.8 |
| 12.51975-12.52025 | 240-285 | 3345.8-3358 | 36.43-36.5 |
| 12.57675-12.57725 | 322-335.4 | 3600-4400 | (²) |
| 13.36-13.41 | | | |

¹Until February 1, 1999, this restricted band shall be 0.490-0.510

²Above 38.6

(b) Except as provided in paragraphs (d) and (e), the field strength of emission appearing within these frequency bands shall not exceed the limits shown in Section 15.209. At frequencies equal to or less than 1000MHz, Compliance with the limits in Section 15.209 shall be demonstrated using measurement instrumentation employing a CISPR quasi-peak detector. Above 1000MHz, compliance with the emission limits in Section 15.209 shall be demonstrated based on the average value of the measured emissions. The provisions in Section 15.35 apply to these measurements.

10.4.Configuration of EUT on Measurement

The equipment is installed on Radiated Emission Measurement to meet the commission requirements and operating regulations in a manner which tends to maximize its emission characteristics in normal application.

10.5. Operating Condition of EUT

10.5.1. Setup the EUT and simulator as shown as Section 10.1.

10.5.2. Turn on the power of all equipment.

10.5.3. Let the EUT work in TX modes measure it. The transmit frequency are 2402-2480MHz. We select 2402MHz, 2441MHz, and 2480MHz TX frequency to transmit.

10.6. Test Procedure

The EUT and its simulators are placed on a turntable, which is 0.8 meter high above ground (Below 1GHz). The EUT and its simulators are placed on a turntable, which is 1.5 meter high above ground (Above 1GHz). The turntable can rotate 360 degrees to determine the position of the maximum emission level. EUT is set 3.0 meters away from the receiving antenna, which is mounted on an antenna tower. The antenna can be moved up and down between 1.0 meter and 4 meters to find out the maximum emission level. Broadband antenna (calibrated bi-log antenna) is used as receiving antenna. Both horizontal and vertical polarizations of the antenna are set on measurement. In order to find the maximum emission levels, all of the EUT location must be manipulated according to ANSI C63.10:2013 on radiated emission measurement. This EUT was tested in 3 orthogonal positions and the Worst case position data was reported.

During the radiated emission test, the spectrum analyzer was set with the following configurations:

1. The resolution bandwidth and video bandwidth of test receiver/spectrum analyzer is 120kHz for Quasi-peak at frequency below 1GHz.
2. The resolution bandwidth of test receiver/spectrum analyzer is 1MHz and video bandwidth is 3MHz for peak measurement with peak detector at frequency above 1GHz.
3. The resolution bandwidth of test receiver/spectrum analyzer is 1MHz and video bandwidth is 10Hz for Average measurement with peak detection at frequency above 1GHz.
4. All modes of operation were investigated and the worst-case emissions are reported.

10.7.Data Sample

| Frequency (MHz) | Reading (dB μ v) | Factor (dB/m) | Result (dB μ v/m) | Limit (dB μ v/m) | Margin (dB) | Remark |
|-----------------|----------------------|---------------|-----------------------|----------------------|-------------|--------|
| X.XX | 28.66 | -15.19 | 13.47 | 40.0 | -26.53 | QP |

Frequency(MHz) = Emission frequency in MHz

Reading(dB μ v) = Uncorrected Analyzer/Receiver reading

Factor (dB/m) = Antenna factor + Cable Loss – Amplifier gain

Result(dB μ v/m) = Reading(dB μ v) + Factor(dB/m)

Limit (dB μ v/m) = Limit stated in standard

Margin (dB) = Result(dB μ v/m) - Limit (dB μ v/m)

QP = Quasi-peak Reading

Calculation Formula:

Margin(dB) = Result (dB μ V/m)–Limit(dB μ V/m)

Result(dB μ V/m)= Reading(dB μ V)+ Factor(dB/m)

The “Margin” column of the following data tables indicates the degree of compliance with the applicable limit. For example, a margin of -7dB means the emission is 7dB below the limit.

10.8.Tetst Results

Pass.

Test Lab: 3m Anechoic chamber

Note: 1.We tested GFSK mode, $\Pi/4$ -DQPSK Mode and recorded the Worse case data (GFSK mode) for all test mode.

2. Testing is carried out with frequency rang 9kHz to the tenth harmonics, which above 3th Harmonics are attenuated more than 20dB below the permissible limits or the field strength is too small to be measured.

The measurements greater than 20dB below the limit from 9kHz to 30MHz and 18 to 26.5GHz.

The spectrum analyzer plots are attached as below.

Below 1GHz



ACCURATE TECHNOLOGY CO., LTD.

F1,Bldg,A,Changyuan New Material Port Keyuan Rd,
Science & Industry Park,Nanshan Shenzhen,P.R.China

Site: 2# Chamber

Tel:+86-0755-26503290

Fax:+86-0755-26503396

Job No.: LGW2020 #238

Standard: FCC Class B 3M Radiated

Test item: Radiation Test

Temp.(C)/Hum.(%) 23 C / 48 %

EUT: True Wireless BT Earbuds

Mode: TX 2402MHz

Model: CB-TE008

Manufacturer: CLEVER

Polarization: Vertical

Power Source: DC 3.7V

Date: 20/05/06/

Time: 9/48/42

Engineer Signature: WADE

Distance: 3m

Note: Report No.:ATE20200378

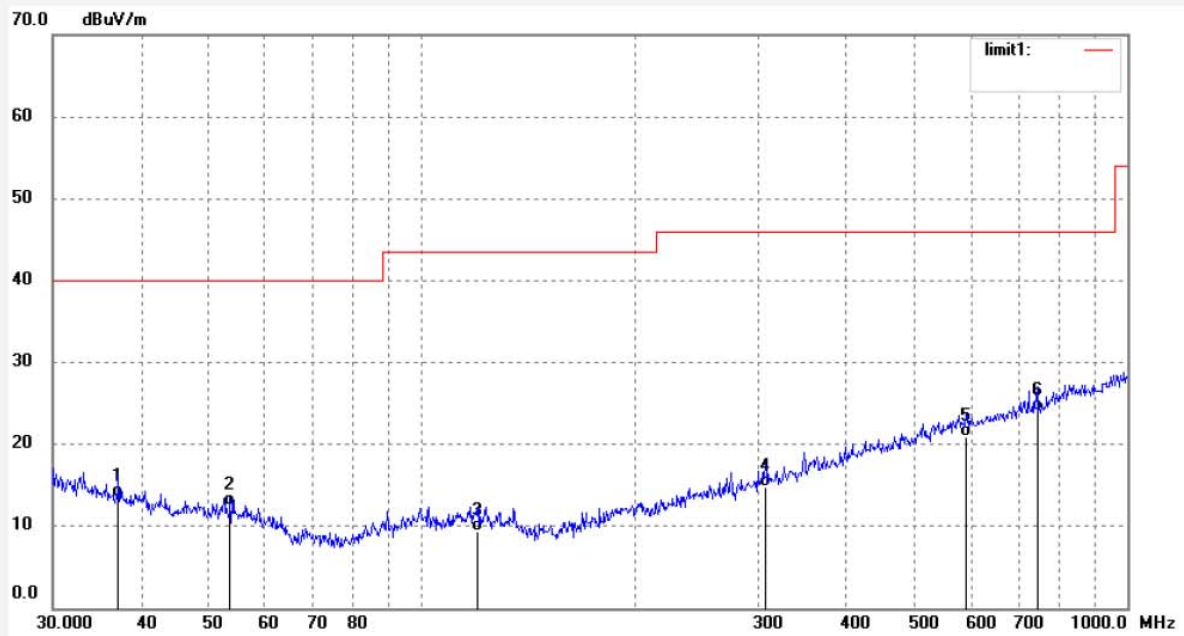

| No. | Freq. (MHz) | Reading (dBuV/m) | Factor (dB) | Result (dBuV/m) | Limit (dBuV/m) | Margin (dB) | Detector | Height (cm) | Degree (deg.) | Remark |
|-----|-------------|------------------|-------------|-----------------|----------------|-------------|----------|-------------|---------------|--------|
| 1 | 37.1550 | 25.47 | -11.90 | 13.57 | 40.00 | -26.43 | QP | 100 | 147 | |
| 2 | 53.5052 | 26.41 | -13.87 | 12.54 | 40.00 | -27.46 | QP | 100 | 258 | |
| 3 | 119.8555 | 23.55 | -14.15 | 9.40 | 43.50 | -34.10 | QP | 100 | 124 | |
| 4 | 306.7536 | 24.89 | -10.14 | 14.75 | 46.00 | -31.25 | QP | 100 | 24 | |
| 5 | 590.9737 | 25.00 | -4.05 | 20.95 | 46.00 | -25.05 | QP | 100 | 236 | |
| 6 | 744.8660 | 26.12 | -2.11 | 24.01 | 46.00 | -21.99 | QP | 100 | 64 | |



ACCURATE TECHNOLOGY CO., LTD.

F1,Bldg,A,Changyuan New Material Port Keyuan Rd,
Science & Industry Park,Nanshan Shenzhen,P.R.China

Site: 2# Chamber

Tel:+86-0755-26503290

Fax:+86-0755-26503396

| | |
|-----------------------------------|--------------------------|
| Job No.: LGW2020 #239 | Polarization: Horizontal |
| Standard: FCC Class B 3M Radiated | Power Source: DC 3.7V |
| Test item: Radiation Test | Date: 20/05/06/ |
| Temp.(C)/Hum.(%) 23 C / 48 % | Time: 9/50/04 |
| EUT: True Wireless BT Earbuds | Engineer Signature: WADE |
| Mode: TX 2402MHz | Distance: 3m |
| Model: CB-TE008 | |
| Manufacturer: CLEVER | |

Note: Report No.:ATE20200378

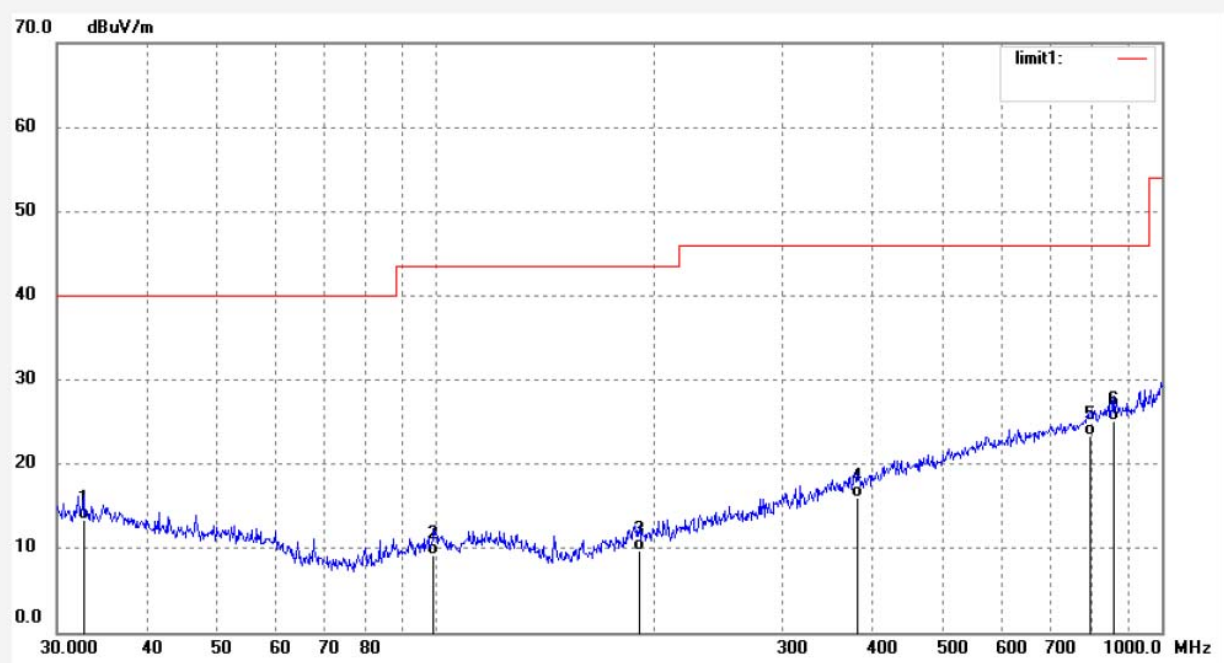

| No. | Freq. (MHz) | Reading (dBuV/m) | Factor (dB) | Result (dBuV/m) | Limit (dBuV/m) | Margin (dB) | Detector | Height (cm) | Degree (deg.) | Remark |
|-----|-------------|------------------|-------------|-----------------|----------------|-------------|----------|-------------|---------------|--------|
| 1 | 32.6340 | 24.52 | -11.19 | 13.33 | 40.00 | -26.67 | QP | 200 | 21 | |
| 2 | 99.1796 | 23.66 | -14.40 | 9.26 | 43.50 | -34.24 | QP | 200 | 23 | |
| 3 | 190.4050 | 23.32 | -13.64 | 9.68 | 43.50 | -33.82 | QP | 200 | 354 | |
| 4 | 381.2485 | 24.36 | -8.32 | 16.04 | 46.00 | -29.96 | QP | 200 | 68 | |
| 5 | 796.1829 | 24.44 | -1.06 | 23.38 | 46.00 | -22.62 | QP | 200 | 128 | |
| 6 | 857.0247 | 25.25 | -0.20 | 25.05 | 46.00 | -20.95 | QP | 200 | 139 | |



ACCURATE TECHNOLOGY CO., LTD.

F1,Bldg,A,Changyuan New Material Port Keyuan Rd,
Science & Industry Park,Nanshan Shenzhen,P.R.China

Site: 2# Chamber
Tel:+86-0755-26503290
Fax:+86-0755-26503396

Job No.: LGW2020 #240

Standard: FCC Class B 3M Radiated

Test item: Radiation Test

Temp.(C)/Hum.(%) 23 C / 48 %

EUT: True Wireless BT Earbuds

Mode: TX 2441MHz

Model: CB-TE008

Manufacturer: CLEVER

Polarization: Horizontal

Power Source: DC 3.7V

Date: 20/05/06/

Time: 9/51/13

Engineer Signature: WADE

Distance: 3m

Note: Report No.:ATE20200378

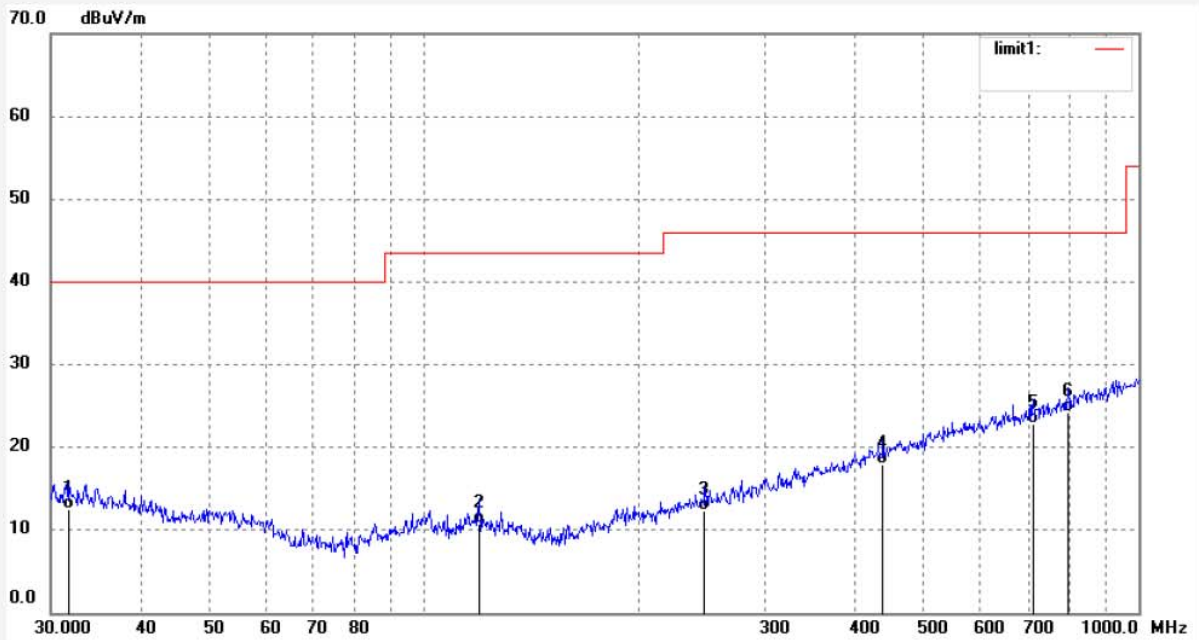

| No. | Freq. (MHz) | Reading (dBuV/m) | Factor (dB) | Result (dBuV/m) | Limit (dBuV/m) | Margin (dB) | Detector | Height (cm) | Degree (deg.) | Remark |
|-----|-------------|------------------|-------------|-----------------|----------------|-------------|----------|-------------|---------------|--------|
| 1 | 31.8427 | 23.69 | -11.10 | 12.59 | 40.00 | -27.41 | QP | 100 | 35 | |
| 2 | 119.4360 | 24.86 | -14.15 | 10.71 | 43.50 | -32.79 | QP | 100 | 235 | |
| 3 | 246.8148 | 24.08 | -11.80 | 12.28 | 46.00 | -33.72 | QP | 100 | 68 | |
| 4 | 438.6553 | 24.91 | -6.92 | 17.99 | 46.00 | -28.01 | QP | 100 | 39 | |
| 5 | 711.6734 | 25.48 | -2.59 | 22.89 | 46.00 | -23.11 | QP | 100 | 123 | |
| 6 | 796.1829 | 25.22 | -1.06 | 24.16 | 46.00 | -21.84 | QP | 100 | 56 | |



ACCURATE TECHNOLOGY CO., LTD.

F1,Bldg,A,Changyuan New Material Port Keyuan Rd,
Science & Industry Park,Nanshan Shenzhen,P.R.China

Site: 2# Chamber
Tel:+86-0755-26503290
Fax:+86-0755-26503396

Job No.: LGW2020 #241
Standard: FCC Class B 3M Radiated
Test item: Radiation Test
Temp.(C)/Hum.(%) 23 C / 48 %
EUT: True Wireless BT Earbuds
Mode: TX 2441MHz
Model: CB-TE008
Manufacturer: CLEVER

Polarization: Vertical
Power Source: DC 3.7V
Date: 20/05/06/
Time: 9/52/33
Engineer Signature: WADE
Distance: 3m

Note: Report No.:ATE20200378

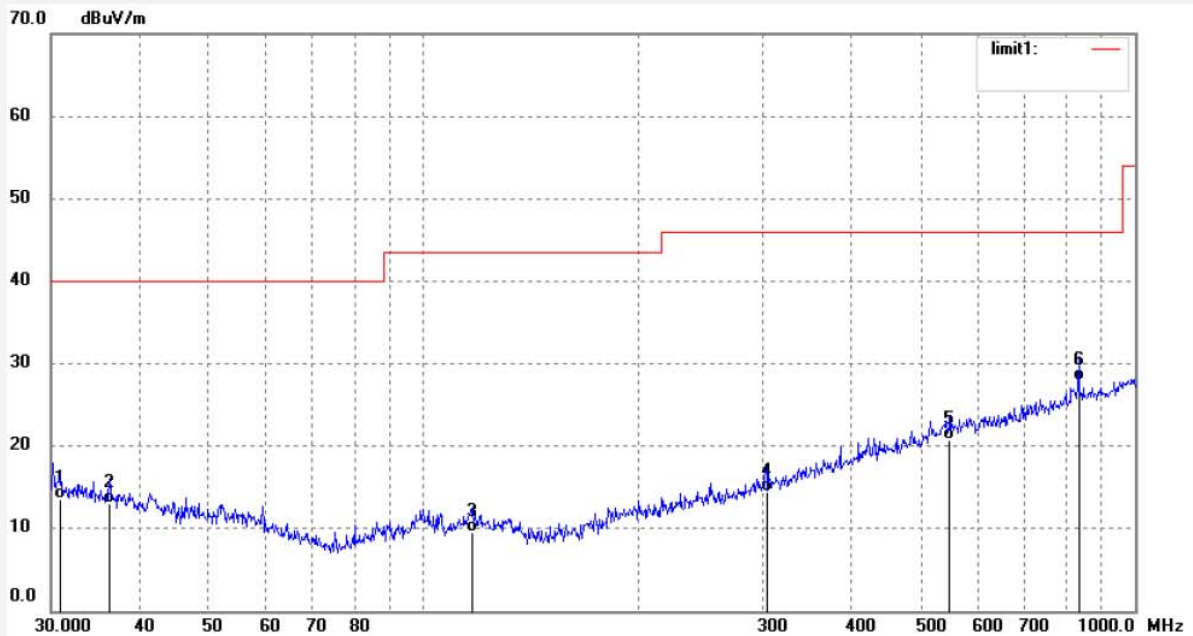

| No. | Freq. (MHz) | Reading (dBuV/m) | Factor (dB) | Result (dBuV/m) | Limit (dBuV/m) | Margin (dB) | Detector | Height (cm) | Degree (deg.) | Remark |
|-----|-------------|------------------|-------------|-----------------|----------------|-------------|----------|-------------|---------------|--------|
| 1 | 30.9618 | 23.74 | -10.21 | 13.53 | 40.00 | -26.47 | QP | 100 | 39 | |
| 2 | 36.2541 | 24.78 | -11.71 | 13.07 | 40.00 | -26.93 | QP | 100 | 24 | |
| 3 | 116.9495 | 23.66 | -14.15 | 9.51 | 43.50 | -33.99 | QP | 100 | 254 | |
| 4 | 303.5437 | 24.69 | -10.24 | 14.45 | 46.00 | -31.55 | QP | 100 | 245 | |
| 5 | 549.0193 | 25.43 | -4.65 | 20.78 | 46.00 | -25.22 | QP | 100 | 235 | |
| 6 | 833.3170 | 28.26 | -0.41 | 27.85 | 46.00 | -18.15 | QP | 100 | 354 | |



ACCURATE TECHNOLOGY CO., LTD.

F1,Bldg,A,Changyuan New Material Port Keyuan Rd,
Science & Industry Park,Nanshan Shenzhen,P.R.China

Site: 2# Chamber
Tel:+86-0755-26503290
Fax:+86-0755-26503396

Job No.: LGW2020 #242

Standard: FCC Class B 3M Radiated

Test item: Radiation Test

Temp.(C)/Hum.(%) 23 C / 48 %

EUT: True Wireless BT Earbuds

Mode: TX 2480MHz

Model: CB-TE008

Manufacturer: CLEVER

Polarization: Vertical

Power Source: DC 3.7V

Date: 20/05/06/

Time: 9/53/52

Engineer Signature: WADE

Distance: 3m

Note: Report No.:ATE20200378

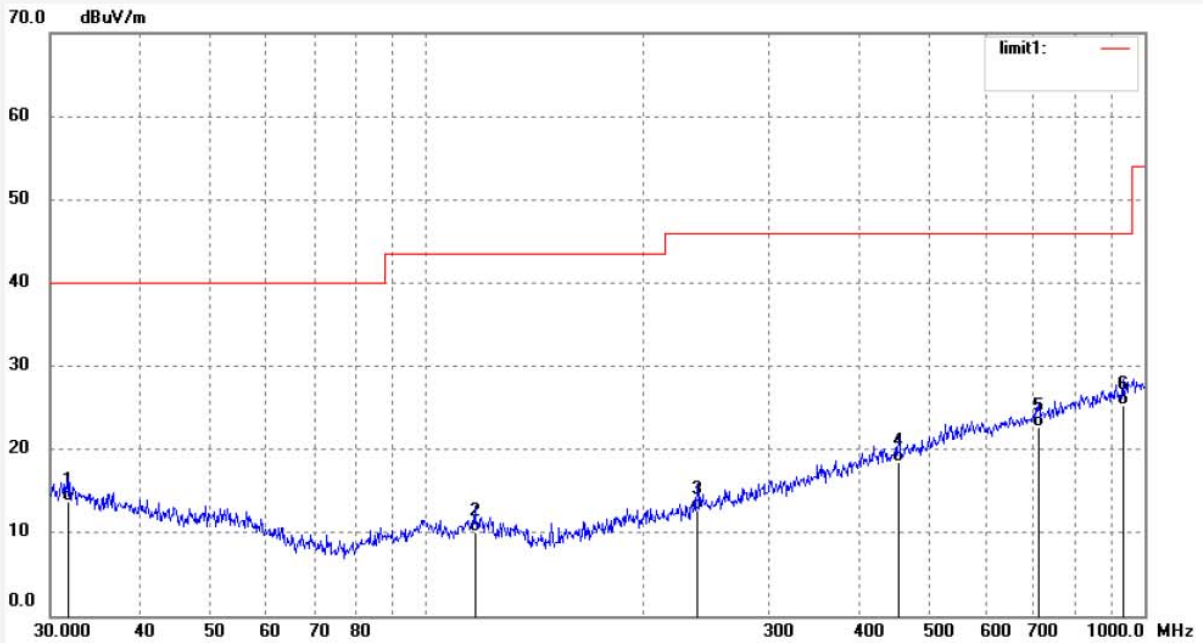

| No. | Freq. (MHz) | Reading (dBuV/m) | Factor (dB) | Result (dBuV/m) | Limit (dBuV/m) | Margin (dB) | Detector | Height (cm) | Degree (deg.) | Remark |
|-----|-------------|------------------|-------------|-----------------|----------------|-------------|----------|-------------|---------------|--------|
| 1 | 31.8427 | 24.18 | -10.47 | 13.71 | 40.00 | -26.29 | QP | 200 | 38 | |
| 2 | 116.9495 | 24.30 | -14.15 | 10.15 | 43.50 | -33.35 | QP | 200 | 234 | |
| 3 | 238.3102 | 24.68 | -11.91 | 12.77 | 46.00 | -33.23 | QP | 200 | 265 | |
| 4 | 454.3100 | 25.23 | -6.72 | 18.51 | 46.00 | -27.49 | QP | 200 | 34 | |
| 5 | 711.6734 | 25.21 | -2.59 | 22.62 | 46.00 | -23.38 | QP | 200 | 247 | |
| 6 | 932.2714 | 24.51 | 0.85 | 25.36 | 46.00 | -20.64 | QP | 200 | 79 | |



ACCURATE TECHNOLOGY CO., LTD.

F1,Bldg,A,Changyuan New Material Port Keyuan Rd,
Science & Industry Park,Nanshan Shenzhen,P.R.China

Site: 2# Chamber

Tel:+86-0755-26503290

Fax:+86-0755-26503396

Job No.: LGW2020 #243

Standard: FCC Class B 3M Radiated

Test item: Radiation Test

Temp.(C)/Hum.(%) 23 C / 48 %

EUT: True Wireless BT Earbuds

Mode: TX 2480MHz

Model: CB-TE008

Manufacturer: CLEVER

Polarization: Horizontal

Power Source: DC 3.7V

Date: 20/05/06/

Time: 9/55/00

Engineer Signature: WADE

Distance: 3m

Note: Report No.:ATE20200378

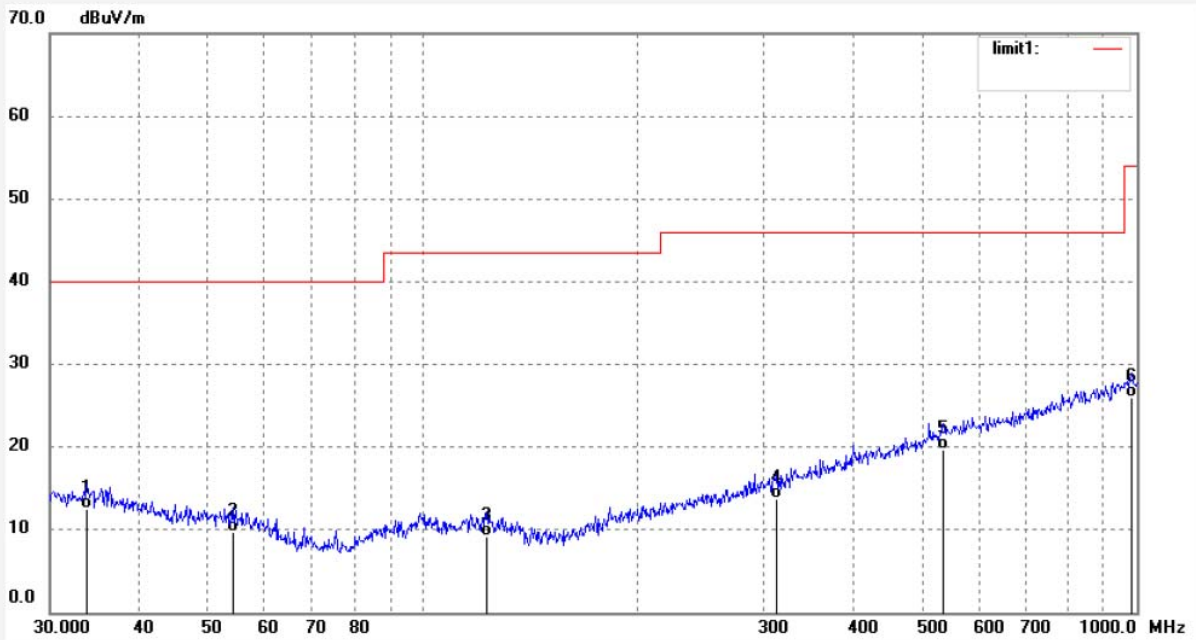

| No. | Freq. (MHz) | Reading (dBuV/m) | Factor (dB) | Result (dBuV/m) | Limit (dBuV/m) | Margin (dB) | Detector | Height (cm) | Degree (deg.) | Remark |
|-----|-------------|------------------|-------------|-----------------|----------------|-------------|----------|-------------|---------------|--------|
| 1 | 33.7986 | 23.78 | -11.30 | 12.48 | 40.00 | -27.52 | QP | 100 | 224 | |
| 2 | 54.0711 | 23.61 | -13.91 | 9.70 | 40.00 | -30.30 | QP | 100 | 242 | |
| 3 | 122.8340 | 23.67 | -14.47 | 9.20 | 43.50 | -34.30 | QP | 100 | 356 | |
| 4 | 313.2760 | 23.72 | -9.93 | 13.79 | 46.00 | -32.21 | QP | 100 | 98 | |
| 5 | 535.7073 | 24.69 | -4.92 | 19.77 | 46.00 | -26.23 | QP | 100 | 75 | |
| 6 | 982.6200 | 24.30 | 1.63 | 25.93 | 54.00 | -28.07 | QP | 100 | 52 | |

Above 1GHz



ACCURATE TECHNOLOGY CO., LTD.

F1,Bldg,A,Changyuan New Material Port Keyuan Rd,
Science & Industry Park,Nanshan Shenzhen,P.R.China

Site: 2# Chamber

Tel:+86-0755-26503290

Fax:+86-0755-26503396

Job No.: LGW2020 #220

Standard: FCC PK

Test item: Radiation Test

Temp.(C)/Hum.(%) 23 C / 48 %

EUT: True Wireless BT Earbuds

Mode: TX 2402MHz

Model: CB-TE008

Manufacturer: CLEVER

Polarization: Horizontal

Power Source: DC 3.7V

Date: 20/05/06/

Time: 9/13/11

Engineer Signature: WADE

Distance: 3m

Note: Report No.:ATE20200378

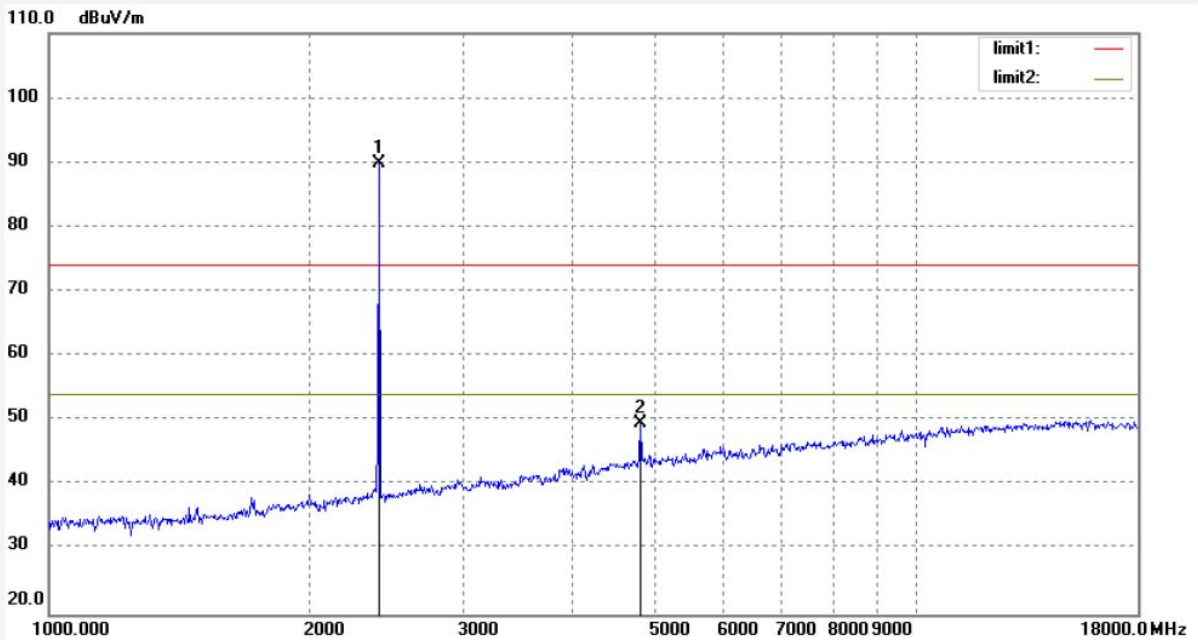

| No. | Freq. (MHz) | Reading (dBuV/m) | Factor (dB) | Result (dBuV/m) | Limit (dBuV/m) | Margin (dB) | Detector | Height (cm) | Degree (deg.) | Remark |
|-----|-------------|------------------|-------------|-----------------|----------------|-------------|----------|-------------|---------------|--------|
| 1 | 2402.000 | 88.97 | 0.89 | 89.86 | | | peak | 150 | 351 | |
| 2 | 4804.000 | 42.12 | 7.40 | 49.52 | 74.00 | -24.48 | peak | 150 | 241 | |



ACCURATE TECHNOLOGY CO., LTD.

F1,Bldg,A,Changyuan New Material Port Keyuan Rd,
Science & Industry Park,Nanshan Shenzhen,P.R.China

Site: 2# Chamber
Tel:+86-0755-26503290
Fax:+86-0755-26503396

| | |
|-------------------------------|--------------------------|
| Job No.: LGW2020 #221 | Polarization: Vertical |
| Standard: FCC PK | Power Source: DC 3.7V |
| Test item: Radiation Test | Date: 20/05/06/ |
| Temp.(C)/Hum.(%) 23 C / 48 % | Time: 9/14/23 |
| EUT: True Wireless BT Earbuds | Engineer Signature: WADE |
| Mode: TX 2402MHz | Distance: 3m |
| Model: CB-TE008 | |
| Manufacturer: CLEVER | |

Note: Report No.:ATE20200378

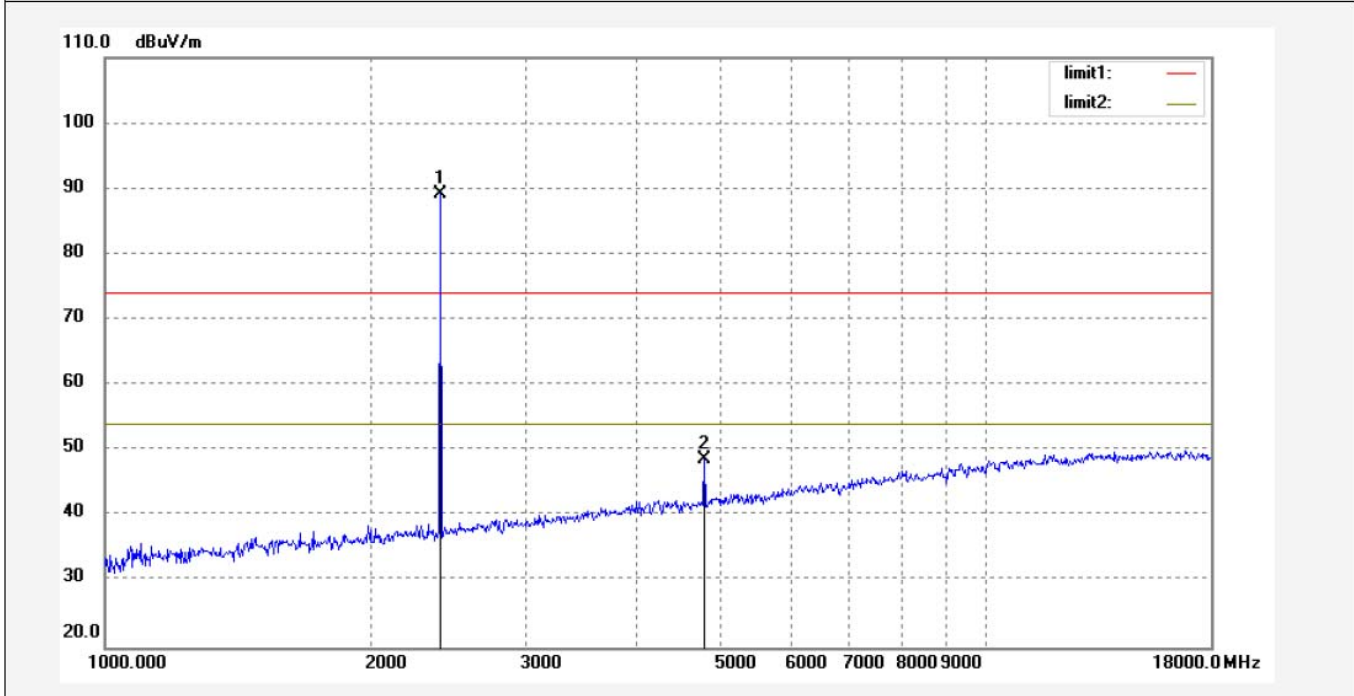

| No. | Freq. (MHz) | Reading (dBuV/m) | Factor (dB) | Result (dBuV/m) | Limit (dBuV/m) | Margin (dB) | Detector | Height (cm) | Degree (deg.) | Remark |
|-----|-------------|------------------|-------------|-----------------|----------------|-------------|----------|-------------|---------------|--------|
| 1 | 2402.000 | 88.22 | 0.89 | 89.11 | | | peak | 200 | 347 | |
| 2 | 4804.000 | 41.39 | 7.40 | 48.79 | 74.00 | -25.21 | peak | 200 | 24 | |



ACCURATE TECHNOLOGY CO., LTD.

F1,Bldg,A,Changyuan New Material Port Keyuan Rd,
Science & Industry Park,Nanshan Shenzhen,P.R.China

Site: 2# Chamber

Tel:+86-0755-26503290

Fax:+86-0755-26503396

Job No.: LGW2020 #222

Standard: FCC PK

Test item: Radiation Test

Temp.(C)/Hum.(%) 23 C / 48 %

EUT: True Wireless BT Earbuds

Mode: TX 2441MHz

Model: CB-TE008

Manufacturer: CLEVER

Polarization: Vertical

Power Source: DC 3.7V

Date: 20/05/06/

Time: 9/16/53

Engineer Signature: WADE

Distance: 3m

Note: Report No.:ATE20200378

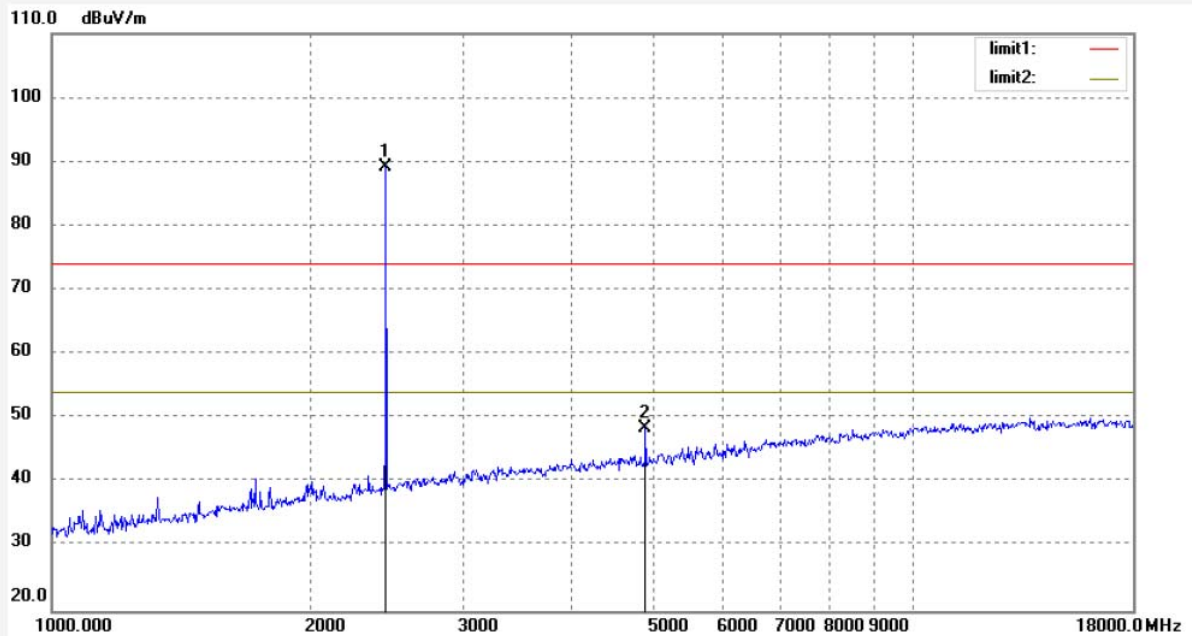

| No. | Freq. (MHz) | Reading (dBuV/m) | Factor (dB) | Result (dBuV/m) | Limit (dBuV/m) | Margin (dB) | Detector | Height (cm) | Degree (deg.) | Remark |
|-----|-------------|------------------|-------------|-----------------|----------------|-------------|----------|-------------|---------------|--------|
| 1 | 2441.000 | 88.06 | 1.06 | 89.12 | | | peak | 150 | 12 | |
| 2 | 4882.000 | 40.25 | 8.11 | 48.36 | 74.00 | -25.64 | peak | 150 | 234 | |



ACCURATE TECHNOLOGY CO., LTD.

F1,Bldg,A,Changyuan New Material Port Keyuan Rd,
Science & Industry Park,Nanshan Shenzhen,P.R.China

Site: 2# Chamber

Tel:+86-0755-26503290

Fax:+86-0755-26503396

Job No.: LGW2020 #223

Standard: FCC PK

Test item: Radiation Test

Temp.(C)/Hum.(%) 23 C / 48 %

EUT: True Wireless BT Earbuds

Mode: TX 2441MHz

Model: CB-TE008

Manufacturer: CLEVER

Polarization: Horizontal

Power Source: DC 3.7V

Date: 20/05/06/

Time: 9/18/00

Engineer Signature: WADE

Distance: 3m

Note: Report No.:ATE20200378

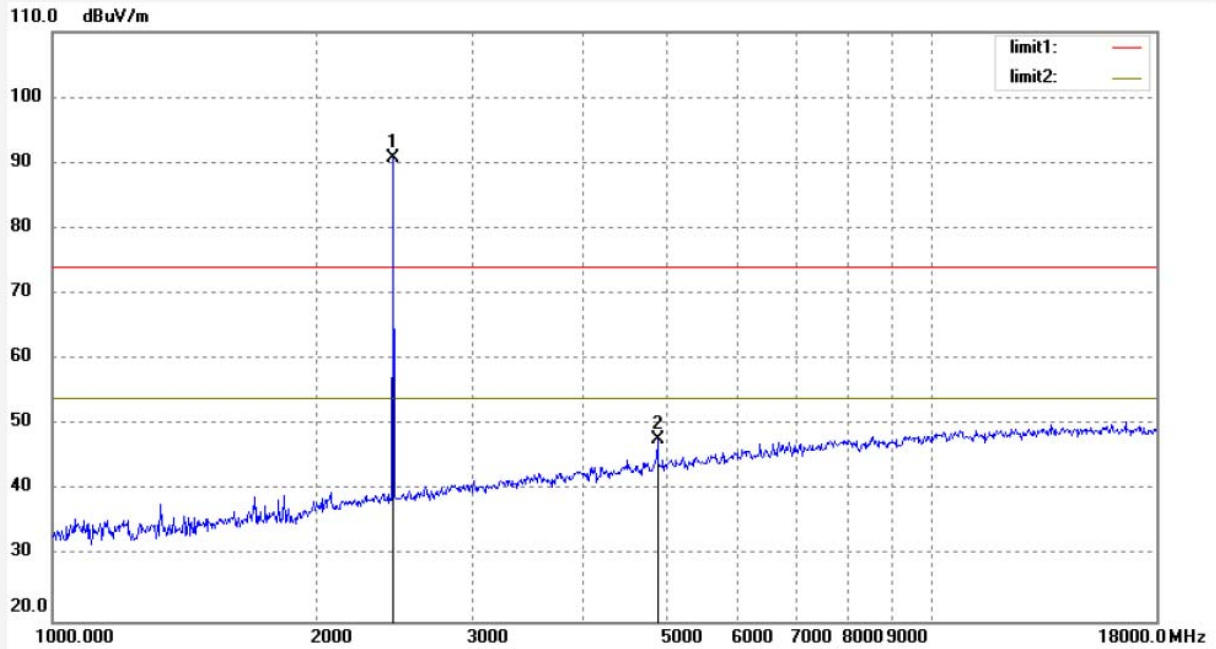

| No. | Freq. (MHz) | Reading (dBuV/m) | Factor (dB) | Result (dBuV/m) | Limit (dBuV/m) | Margin (dB) | Detector | Height (cm) | Degree (deg.) | Remark |
|-----|-------------|------------------|-------------|-----------------|----------------|-------------|----------|-------------|---------------|--------|
| 1 | 2441.000 | 89.81 | 1.06 | 90.87 | | | peak | 250 | 231 | |
| 2 | 4882.000 | 39.59 | 8.11 | 47.70 | 74.00 | -26.30 | peak | 250 | 241 | |



ACCURATE TECHNOLOGY CO., LTD.

F1,Bldg,A,Changyuan New Material Port Keyuan Rd,
Science & Industry Park,Nanshan Shenzhen,P.R.China

Site: 2# Chamber
Tel:+86-0755-26503290
Fax:+86-0755-26503396

Job No.: LGW2020 #224
Standard: FCC PK
Test item: Radiation Test
Temp.(C)/Hum.(%) 23 C / 48 %
EUT: True Wireless BT Earbuds
Mode: TX 2480MHz
Model: CB-TE008
Manufacturer: CLEVER

Polarization: Horizontal
Power Source: DC 3.7V
Date: 20/05/06/
Time: 9/19/44
Engineer Signature: WADE
Distance: 3m

Note: Report No.:ATE20200378

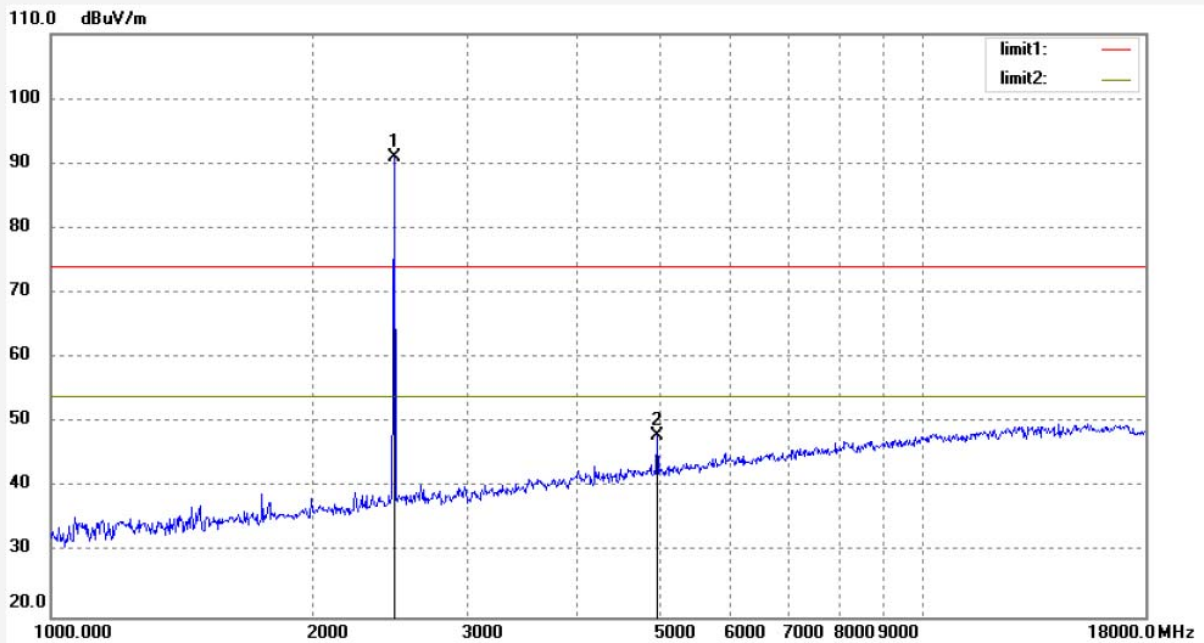

| No. | Freq. (MHz) | Reading (dBuV/m) | Factor (dB) | Result (dBuV/m) | Limit (dBuV/m) | Margin (dB) | Detector | Height (cm) | Degree (deg.) | Remark |
|-----|-------------|------------------|-------------|-----------------|----------------|-------------|----------|-------------|---------------|--------|
| 1 | 2480.000 | 89.96 | 1.10 | 91.06 | | | peak | 250 | 124 | |
| 2 | 4960.000 | 39.48 | 8.60 | 48.08 | 74.00 | -25.92 | peak | 250 | 341 | |



ACCURATE TECHNOLOGY CO., LTD.

F1,Bldg,A,Changyuan New Material Port Keyuan Rd,
Science & Industry Park,Nanshan Shenzhen,P.R.China

Site: 2# Chamber

Tel:+86-0755-26503290

Fax:+86-0755-26503396

| | |
|-------------------------------|--------------------------|
| Job No.: LGW2020 #225 | Polarization: Vertical |
| Standard: FCC PK | Power Source: DC 3.7V |
| Test item: Radiation Test | Date: 20/05/06/ |
| Temp.(C)/Hum.(%) 23 C / 48 % | Time: 9/20/55 |
| EUT: True Wireless BT Earbuds | Engineer Signature: WADE |
| Mode: TX 2480MHz | Distance: 3m |
| Model: CB-TE008 | |
| Manufacturer: CLEVER | |

Note: Report No.:ATE20200378

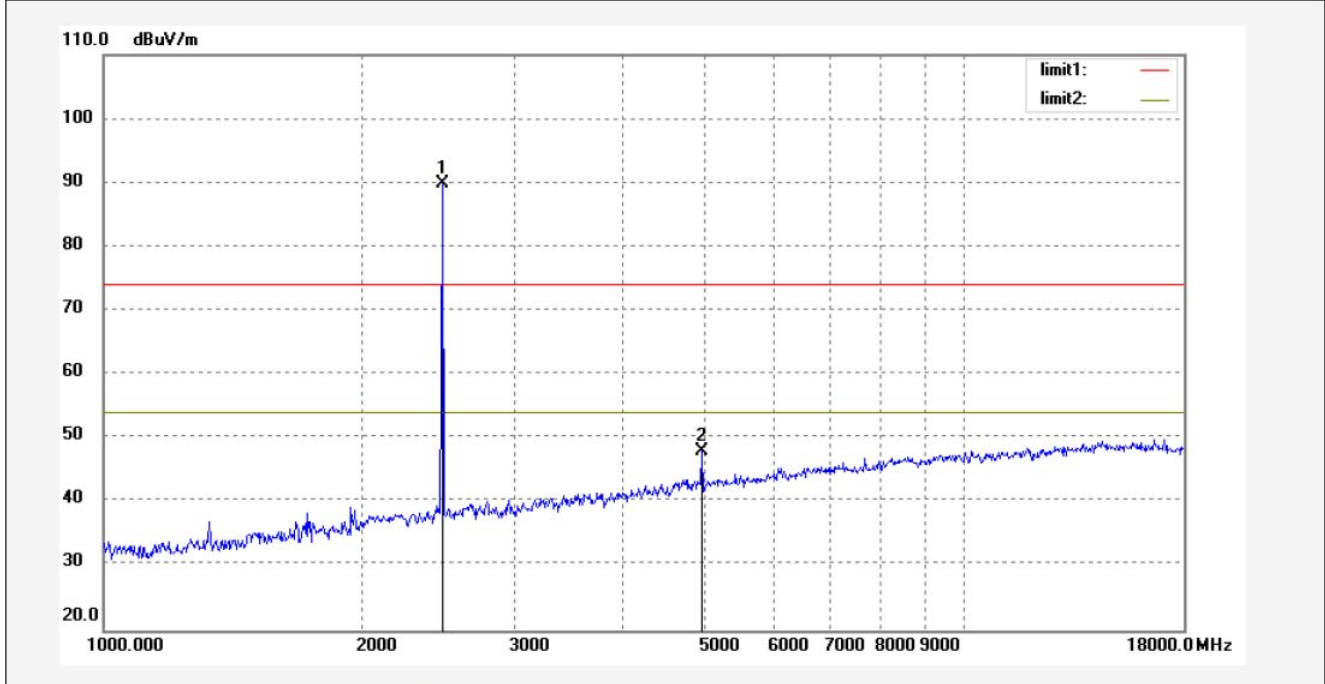

| No. | Freq. (MHz) | Reading (dBuV/m) | Factor (dB) | Result (dBuV/m) | Limit (dBuV/m) | Margin (dB) | Detector | Height (cm) | Degree (deg.) | Remark |
|-----|-------------|------------------|-------------|-----------------|----------------|-------------|----------|-------------|---------------|--------|
| 1 | 2480.000 | 88.87 | 1.10 | 89.97 | | | peak | 200 | 31 | |
| 2 | 4960.000 | 39.50 | 8.60 | 48.10 | 74.00 | -25.90 | peak | 200 | 214 | |

11.BAND EDGE COMPLIANCE TEST

11.1.Block Diagram of Test Setup

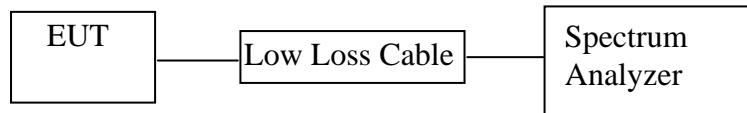

11.2.The Requirement For Section 15.247(d)

Section 15.247(d): In any 100 kHz bandwidth outside the frequency band in which the spread spectrum or digitally modulated intentional radiator is operating, the radio frequency power that is produced by the intentional radiator shall be at least 20 dB below that in the 100 kHz bandwidth within the band that contains the highest level of the desired power, based on either an RF conducted or a radiated measurement, provided the transmitter demonstrates compliance with the peak conducted power limits. If the transmitter complies with the conducted power limits based on the use of RMS averaging over a time interval, as permitted under paragraph (b)(3) of this section, the attenuation required under this paragraph shall be 30 dB instead of 20 dB. Attenuation below the general limits specified in Section 15.209(a) is not required. In addition, radiated emissions which fall in the restricted bands, as defined in Section 15.205(a), must also comply with the radiated emission limits specified in Section 15.209(a).

11.3.EUT Configuration on Measurement

The equipment are installed on the emission Measurement to meet the commission requirements and operating regulations in a manner which tends to maximize its emission characteristics in normal application.

11.4.Operating Condition of EUT

11.4.1.Setup the EUT and simulator as shown as Section 11.1.

11.4.2.Turn on the power of all equipment.

11.4.3.Let the EUT work in TX (Hopping off, Hopping on) modes measure it. The transmit frequency are 2402-2480MHz. We select 2402MHz, 2480MHz TX frequency to transmit.

11.5. Test Procedure

11.5.1. The transmitter output was connected to the spectrum analyzer via a low loss cable.

11.5.2. Set RBW of spectrum analyzer to 100 kHz and VBW to 300 kHz with convenient frequency span including 100 kHz bandwidth from band edge.

11.5.3. The band edges was measured and recorded.

11.6. Test Result

Test Lab: Shielding room

Note: Both hopping-on mode and hopping-off mode had been pre-tested, and only the Worse case was recorded in the test report.

Conducted Band Edge Result

Non-hopping mode

| Frequency (MHz) | Result of Band Edge (dBc) | Limit of Band Edge (dBc) | Result |
|-----------------|---------------------------|--------------------------|--------|
| GFSK Mode | | | |
| 2400.00 | 51.22 | > 20dBc | Pass |
| 2483.50 | 40.59 | > 20dBc | Pass |
| Π/4-DQPSK Mode | | | |
| 2400.00 | 52.46 | > 20dBc | Pass |
| 2483.50 | 43.42 | > 20dBc | Pass |

The spectrum analyzer plots are attached as below.

GFSK Mode

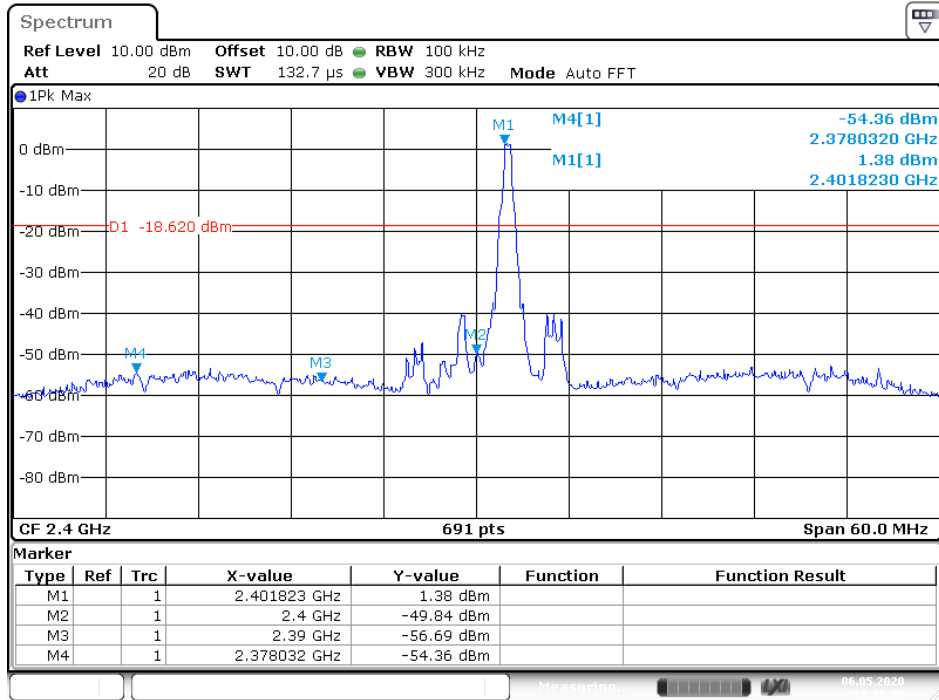

Date: 6.MAY.2020 18:35:05

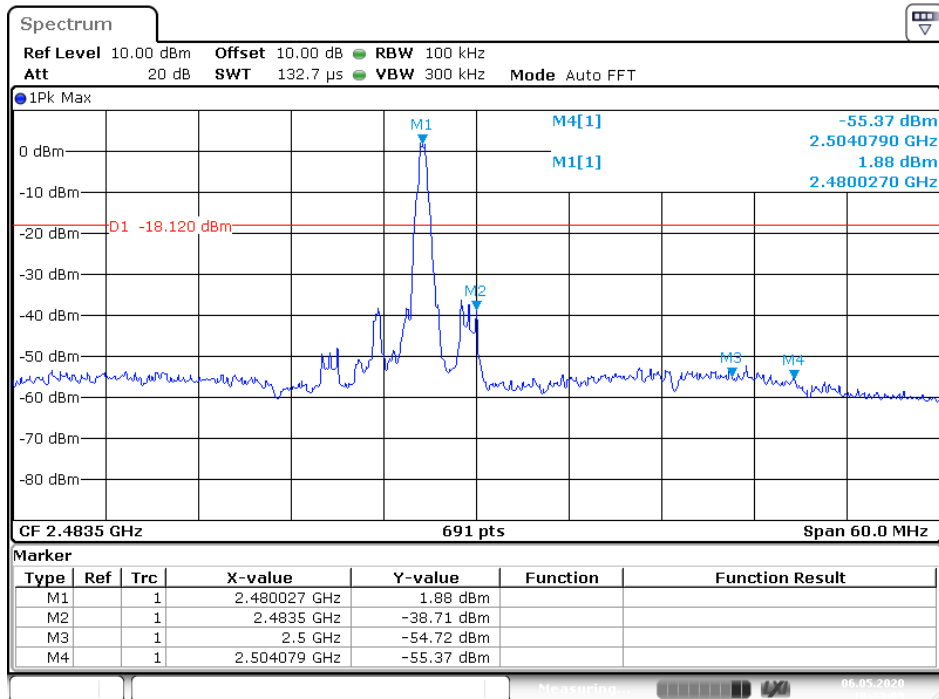

Date: 6.MAY.2020 18:33:10

Π/4-DQPSK Mode

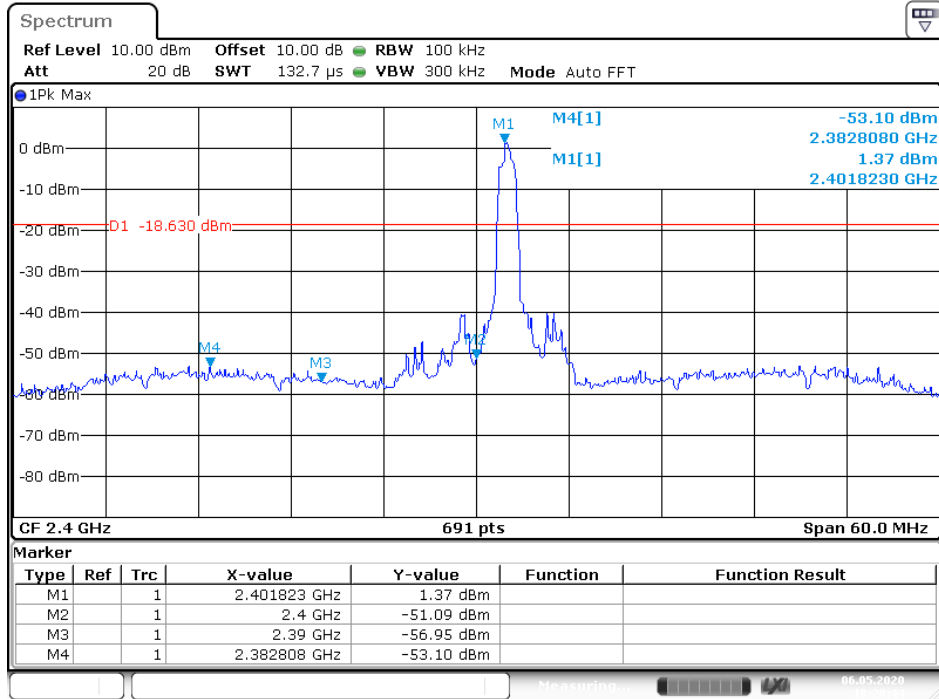

Date: 6.MAY.2020 18:28:44

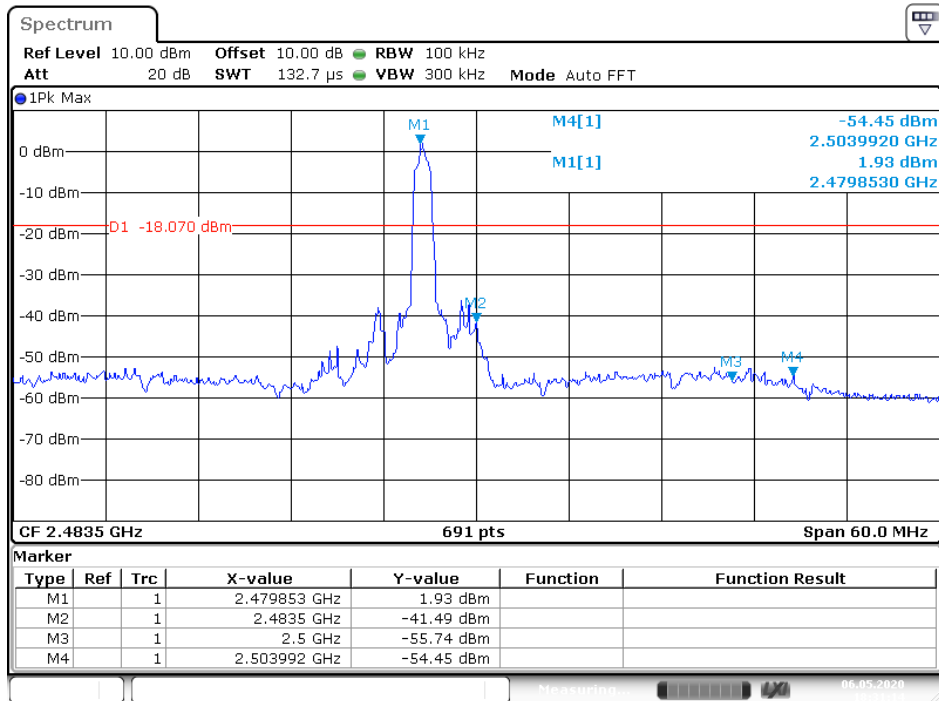

Date: 6.MAY.2020 18:31:14

Radiated Band Edge Result

Note:

1. Emissions attenuated more than 20 dB below the permissible value are not reported.
2. The field strength is calculated by adding the antenna factor, high pass filter loss(if used) and cable loss, and subtracting the amplifier gain(if any)from the measured reading. The basic equation calculation is as follows:

Result = Reading + Corrected Factor

3. Display the measurement of peak values.

Test Procedure:

The EUT and its simulators are placed on a turntable, which is 1.5 meter high above ground(Above 1GHz). The turntable can rotate 360 degrees to determine the position of the maximum emission level. EUT is set 3.0 meters away from the receiving antenna, which is mounted on an antenna tower. The antenna can be moved up and down between 1.0 meter and 4 meters to find out the maximum emission level. Broadband antenna (calibrated bi-log antenna) is used as receiving antenna. Both horizontal and vertical polarizations of the antenna are set on measurement. In order to find the maximum emission levels, all of the EUT location must be manipulated according to ANSI C63.10:2013 on radiated emission measurement. The EUT was tested in 3 orthogonal planes.

Let the EUT work in TX (Hopping off, Hopping on) modes measure it.
We select 2402MHz, 2480MHz TX frequency to transmit(Hopping off mode).
We select 2402-2480MHz TX frequency to transmit(Hopping on mode).

During the radiated emission test, the spectrum analyzer was set with the following configurations:

- 1.The resolution bandwidth of test receiver/spectrum analyzer is 1MHz and video bandwidth is 3MHz for peak measurement with peak detector at frequency above 1GHz.
- 2.The resolution bandwidth of test receiver/spectrum analyzer is 1MHz and video bandwidth is 10Hz for Average measurement with peak detection at frequency above 1GHz.
- 3.All modes of operation were investigated and the worse case (GFSK Mode) emissions are reported.

Test Lab: 3m Anechoic chamber

The spectrum analyzer plots are attached as below.

Non-hopping mode



ACCURATE TECHNOLOGY CO., LTD.

F1,Bldg,A,Changyuan New Material Port Keyuan Rd,
Science & Industry Park,Nanshan Shenzhen,P.R.China

Site: 2# Chamber

Tel:+86-0755-26503290

Fax:+86-0755-26503396

| | |
|-------------------------------|--------------------------|
| Job No.: LGW2020 #226 | Polarization: Vertical |
| Standard: FCC PK | Power Source: DC 3.7V |
| Test item: Radiation Test | Date: 20/05/06/ |
| Temp.(C)/Hum.(%) 23 C / 48 % | Time: 9/22/54 |
| EUT: True Wireless BT Earbuds | Engineer Signature: WADE |
| Mode: TX 2402MHz | Distance: 3m |
| Model: CB-TE008 | |
| Manufacturer: CLEVER | |

Note: Report No.:ATE20200378

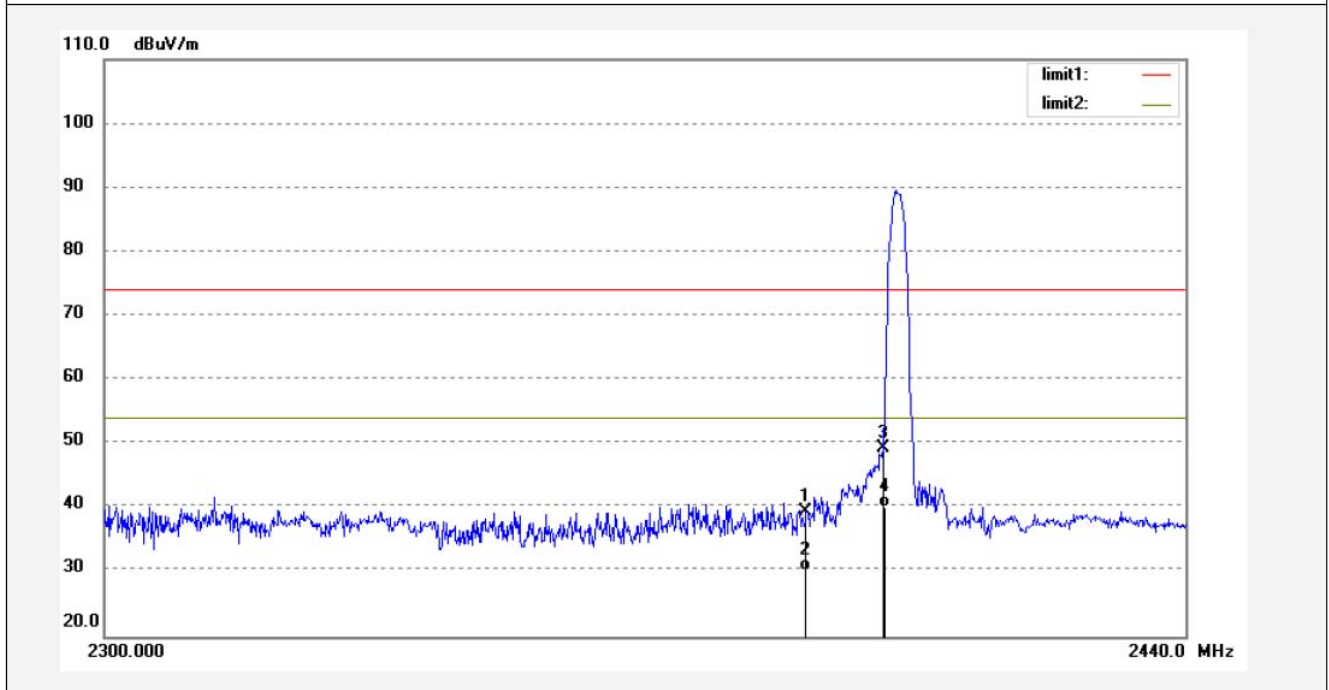

| No. | Freq. (MHz) | Reading (dBuV/m) | Factor (dB) | Result (dBuV/m) | Limit (dBuV/m) | Margin (dB) | Detector | Height (cm) | Degree (deg.) | Remark |
|-----|-------------|------------------|-------------|-----------------|----------------|-------------|----------|-------------|---------------|--------|
| 1 | 2390.000 | 38.59 | 0.79 | 39.38 | 74.00 | -34.62 | peak | 200 | 234 | |
| 2 | 2390.000 | 29.45 | 0.79 | 30.24 | 54.00 | -23.76 | AVG | 200 | 34 | |
| 3 | 2400.000 | 48.50 | 0.88 | 49.38 | 74.00 | -24.62 | peak | 200 | 254 | |
| 4 | 2400.000 | 39.36 | 0.88 | 40.24 | 54.00 | -13.76 | AVG | 200 | 124 | |

Note: Average measurement with peak detection at No.2&4



ACCURATE TECHNOLOGY CO., LTD.

F1,Bldg,A,Changyuan New Material Port Keyuan Rd,
Science & Industry Park,Nanshan Shenzhen,P.R.China

Site: 2# Chamber
Tel:+86-0755-26503290
Fax:+86-0755-26503396

| | |
|-------------------------------|--------------------------|
| Job No.: LGW2020 #227 | Polarization: Horizontal |
| Standard: FCC PK | Power Source: DC 3.7V |
| Test item: Radiation Test | Date: 20/05/06/ |
| Temp.(C)/Hum.(%) 23 C / 48 % | Time: 9/24/07 |
| EUT: True Wireless BT Earbuds | Engineer Signature: WADE |
| Mode: TX 2402MHz | Distance: 3m |
| Model: CB-TE008 | |
| Manufacturer: CLEVER | |

Note: Report No.:ATE20200378

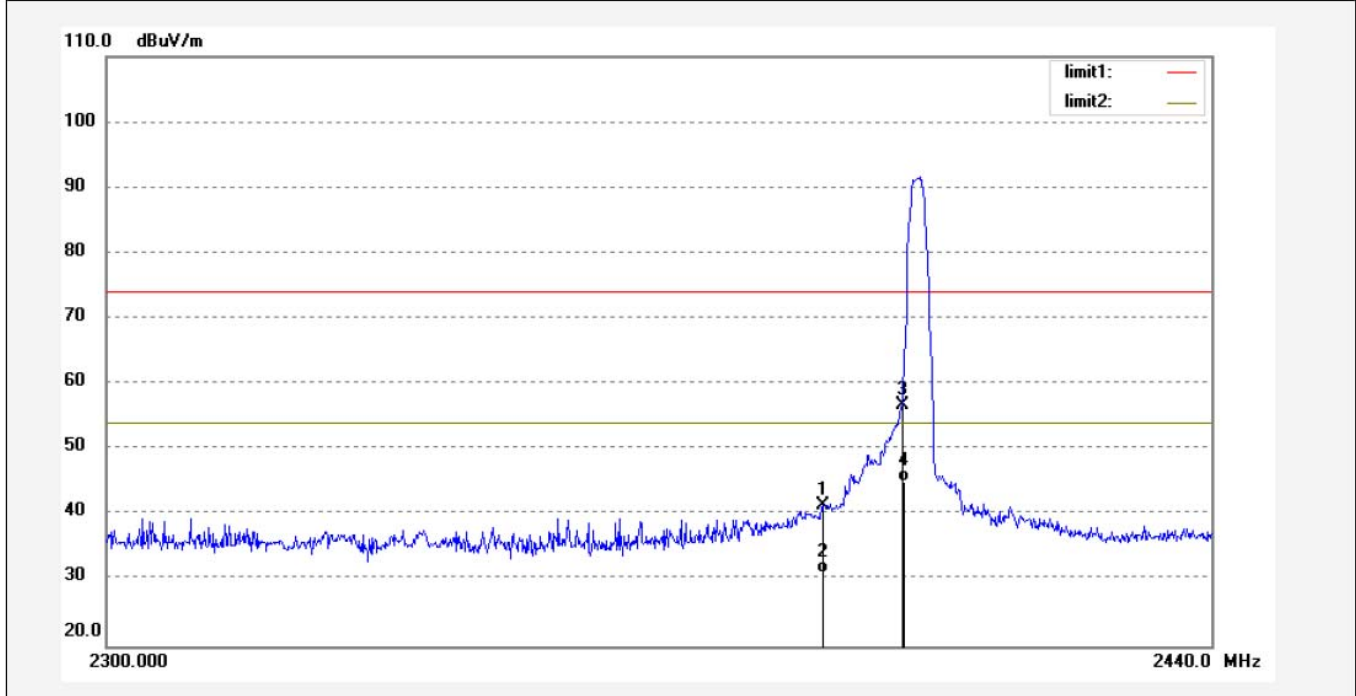

| No. | Freq. (MHz) | Reading (dBuV/m) | Factor (dB) | Result (dBuV/m) | Limit (dBuV/m) | Margin (dB) | Detector | Height (cm) | Degree (deg.) | Remark |
|-----|-------------|------------------|-------------|-----------------|----------------|-------------|----------|-------------|---------------|--------|
| 1 | 2390.000 | 40.67 | 0.79 | 41.46 | 74.00 | -32.54 | peak | 150 | 241 | |
| 2 | 2390.000 | 30.42 | 0.79 | 31.21 | 54.00 | -22.79 | AVG | 150 | 123 | |
| 3 | 2400.000 | 55.81 | 0.88 | 56.69 | 74.00 | -17.31 | peak | 150 | 147 | |
| 4 | 2400.000 | 44.13 | 0.88 | 45.01 | 54.00 | -8.99 | AVG | 150 | 258 | |

Note: Average measurement with peak detection at No.2&4



ACCURATE TECHNOLOGY CO., LTD.

F1,Bldg,A,Changyuan New Material Port Keyuan Rd,
Science & Industry Park,Nanshan Shenzhen,P.R.China

Site: 2# Chamber
Tel:+86-0755-26503290
Fax:+86-0755-26503396

| | |
|-------------------------------|--------------------------|
| Job No.: LGW2020 #234 | Polarization: Vertical |
| Standard: FCC PK | Power Source: DC 3.7V |
| Test item: Radiation Test | Date: 20/05/06/ |
| Temp.(C)/Hum.(%) 23 C / 48 % | Time: 9/35/42 |
| EUT: True Wireless BT Earbuds | Engineer Signature: WADE |
| Mode: TX 2480MHz | Distance: 3m |
| Model: CB-TE008 | |
| Manufacturer: CLEVER | |

Note: Report No.:ATE20200378

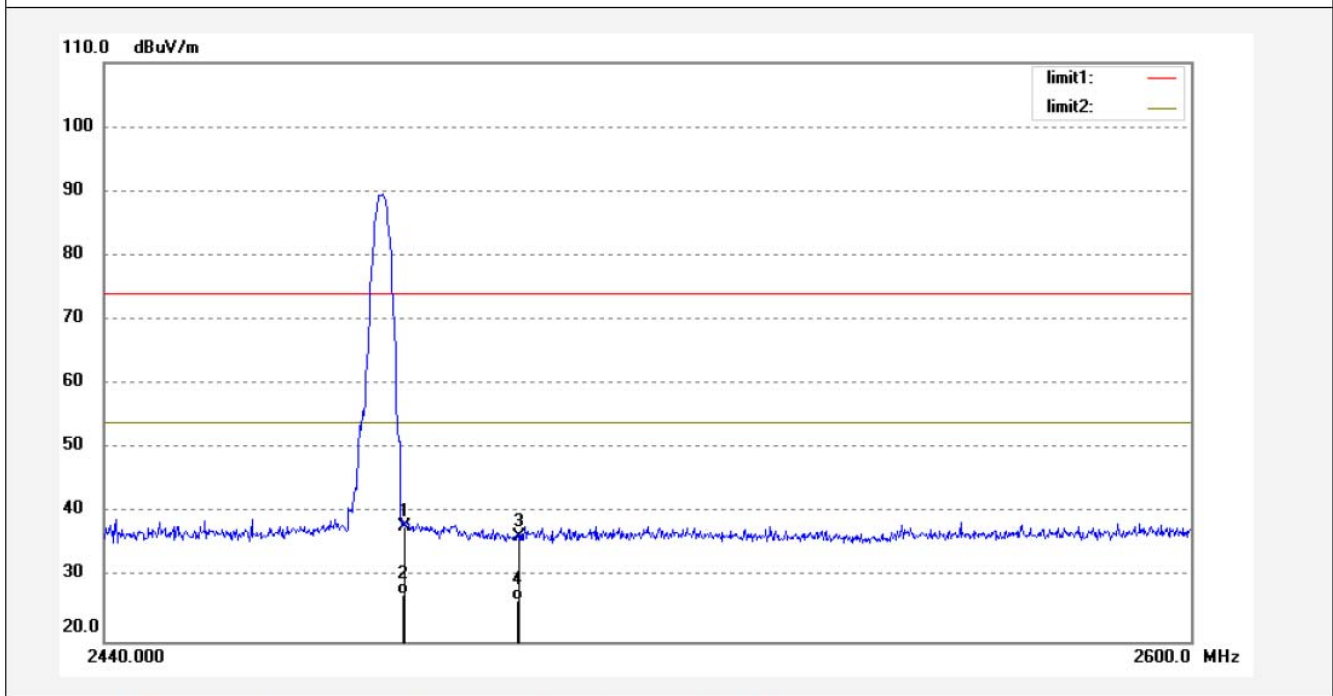

| No. | Freq. (MHz) | Reading (dBuV/m) | Factor (dB) | Result (dBuV/m) | Limit (dBuV/m) | Margin (dB) | Detector | Height (cm) | Degree (deg.) | Remark |
|-----|-------------|------------------|-------------|-----------------|----------------|-------------|----------|-------------|---------------|--------|
| 1 | 2483.500 | 36.89 | 1.10 | 37.99 | 74.00 | -36.01 | peak | 200 | 12 | |
| 2 | 2483.500 | 26.21 | 1.10 | 27.31 | 54.00 | -26.69 | AVG | 200 | 352 | |
| 3 | 2500.000 | 35.22 | 1.10 | 36.32 | 74.00 | -37.68 | peak | 200 | 241 | |
| 4 | 2500.000 | 25.24 | 1.10 | 26.34 | 54.00 | -27.66 | AVG | 200 | 123 | |

Note: Average measurement with peak detection at No.2&4



ACCURATE TECHNOLOGY CO., LTD.

F1,Bldg,A,Changyuan New Material Port Keyuan Rd,
Science & Industry Park,Nanshan Shenzhen,P.R.China

Site: 2# Chamber
Tel:+86-0755-26503290
Fax:+86-0755-26503396

Job No.: LGW2020 #235

Standard: FCC PK

Test item: Radiation Test

Temp.(C)/Hum.(%) 23 C / 48 %

EUT: True Wireless BT Earbuds

Mode: TX 2480MHz

Model: CB-TE008

Manufacturer: CLEVER

Polarization: Horizontal

Power Source: DC 3.7V

Date: 20/05/06/

Time: 9/36/28

Engineer Signature: WADE

Distance: 3m

Note: Report No.:ATE20200378

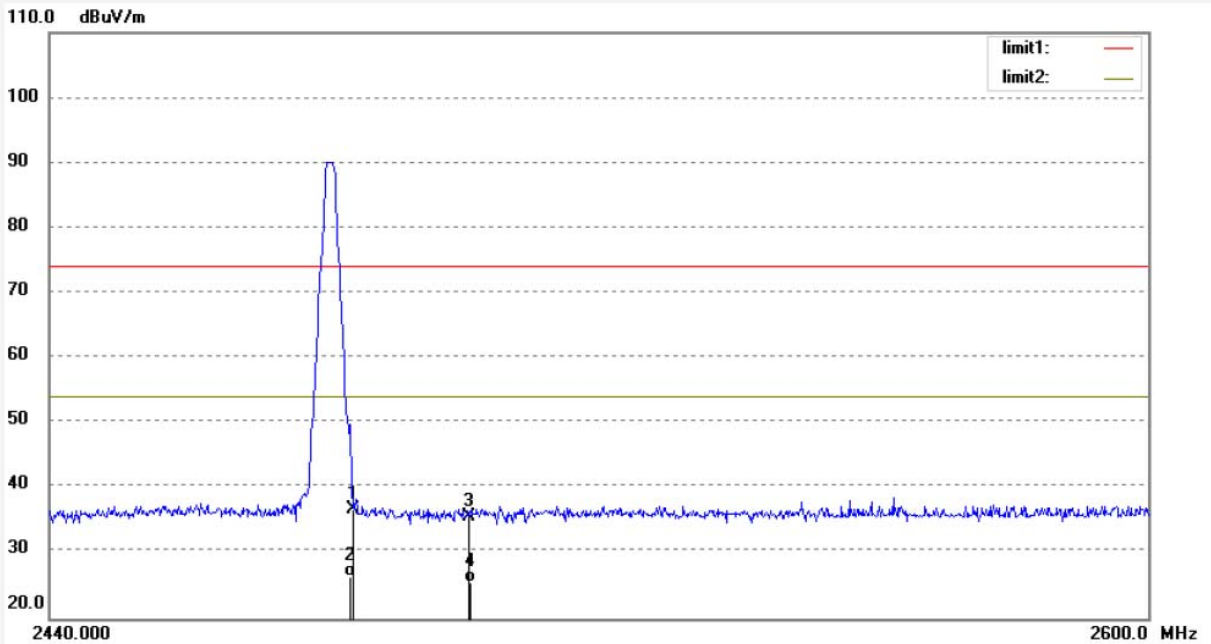

| No. | Freq. (MHz) | Reading (dBuV/m) | Factor (dB) | Result (dBuV/m) | Limit (dBuV/m) | Margin (dB) | Detector | Height (cm) | Degree (deg.) | Remark |
|-----|-------------|------------------|-------------|-----------------|----------------|-------------|----------|-------------|---------------|--------|
| 1 | 2483.500 | 35.65 | 1.10 | 36.75 | 74.00 | -37.25 | peak | 250 | 35 | |
| 2 | 2483.500 | 25.21 | 1.10 | 26.31 | 54.00 | -27.69 | AVG | 250 | 235 | |
| 3 | 2500.000 | 34.56 | 1.10 | 35.66 | 74.00 | -38.34 | peak | 250 | 125 | |
| 4 | 2500.000 | 24.31 | 1.10 | 25.41 | 54.00 | -28.59 | AVG | 250 | 123 | |

Note: Average measurement with peak detection at No.2&4

Hopping mode



ACCURATE TECHNOLOGY CO., LTD.

F1,Bldg,A,Changyuan New Material Port Keyuan Rd,
Science & Industry Park,Nanshan Shenzhen,P.R.China

Site: 2# Chamber

Tel:+86-0755-26503290

Fax:+86-0755-26503396

Job No.: LGW2020 #236

Standard: FCC PK

Test item: Radiation Test

Temp.(C)/Hum.(%) 23 C / 48 %

EUT: True Wireless BT Earbuds

Mode: Hopping

Model: CB-TE008

Manufacturer: CLEVER

Polarization: Horizontal

Power Source: DC 3.7V

Date: 20/05/06/

Time: 9/39/18

Engineer Signature: WADE

Distance: 3m

Note: Report No.:ATE20200378

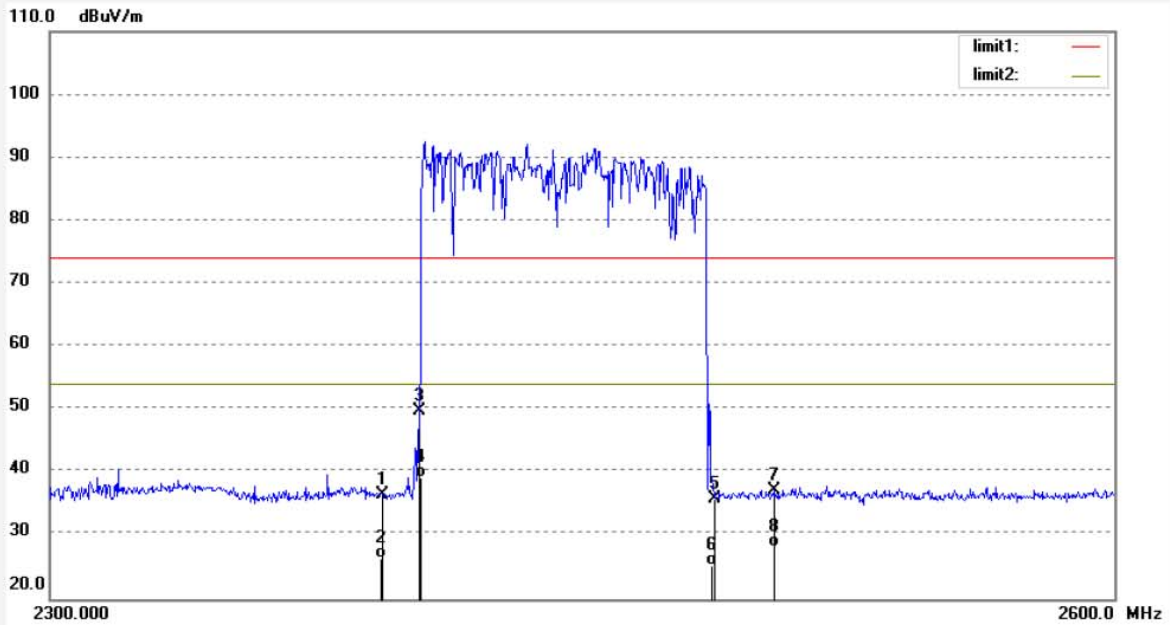

| No. | Freq. (MHz) | Reading (dBuV/m) | Factor (dB) | Result (dBuV/m) | Limit (dBuV/m) | Margin (dB) | Detector | Height (cm) | Degree (deg.) | Remark |
|-----|-------------|------------------|-------------|-----------------|----------------|-------------|----------|-------------|---------------|--------|
| 1 | 2390.000 | 35.86 | 0.79 | 36.65 | 74.00 | -37.35 | peak | 200 | 121 | |
| 2 | 2390.000 | 25.53 | 0.79 | 26.32 | 54.00 | -27.68 | AVG | 200 | 65 | |
| 3 | 2400.000 | 48.91 | 0.88 | 49.79 | 74.00 | -24.21 | peak | 200 | 248 | |
| 4 | 2400.000 | 38.36 | 0.88 | 39.24 | 54.00 | -14.76 | AVG | 200 | 233 | |
| 5 | 2483.500 | 34.77 | 1.10 | 35.87 | 74.00 | -38.13 | peak | 200 | 334 | |
| 6 | 2483.500 | 24.24 | 1.10 | 25.34 | 54.00 | -28.66 | AVG | 200 | 235 | |
| 7 | 2500.000 | 36.09 | 1.10 | 37.19 | 74.00 | -36.81 | peak | 200 | 24 | |
| 8 | 2500.000 | 27.14 | 1.10 | 28.24 | 54.00 | -25.76 | AVG | 200 | 231 | |

Note: Average measurement with peak detection at No.2&4&6&8



ACCURATE TECHNOLOGY CO., LTD.

F1,Bldg,A,Changyuan New Material Port Keyuan Rd,
Science & Industry Park,Nanshan Shenzhen,P.R.China

Site: 2# Chamber
Tel:+86-0755-26503290
Fax:+86-0755-26503396

| | |
|-------------------------------|--------------------------|
| Job No.: LGW2020 #237 | Polarization: Vertical |
| Standard: FCC PK | Power Source: DC 3.7V |
| Test item: Radiation Test | Date: 20/05/06/ |
| Temp.(C)/Hum.(%) 23 C / 48 % | Time: 9/41/25 |
| EUT: True Wireless BT Earbuds | Engineer Signature: WADE |
| Mode: Hopping | Distance: 3m |
| Model: CB-TE008 | |
| Manufacturer: CLEVER | |

Note: Report No.:ATE20200378

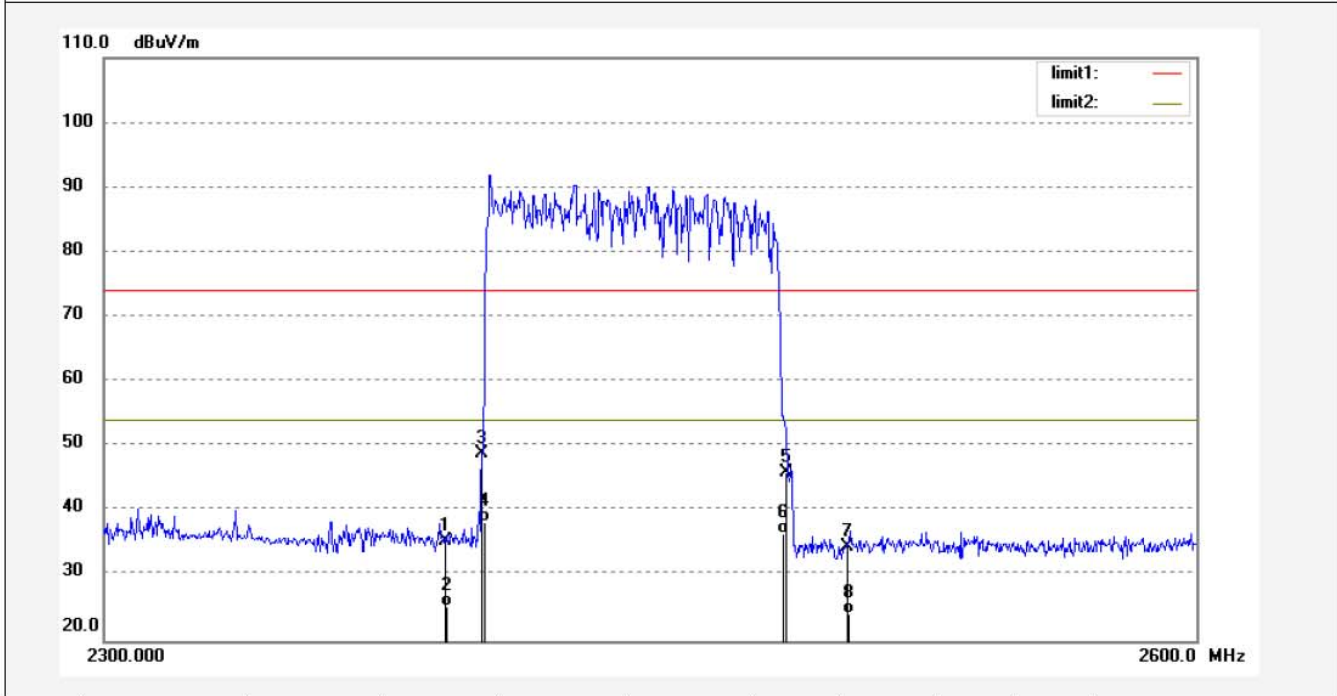

| No. | Freq. (MHz) | Reading (dBuV/m) | Factor (dB) | Result (dBuV/m) | Limit (dBuV/m) | Margin (dB) | Detector | Height (cm) | Degree (deg.) | Remark |
|-----|-------------|------------------|-------------|-----------------|----------------|-------------|----------|-------------|---------------|--------|
| 1 | 2390.000 | 34.64 | 0.79 | 35.43 | 74.00 | -38.57 | peak | 150 | 245 | |
| 2 | 2390.000 | 24.45 | 0.79 | 25.24 | 54.00 | -28.76 | AVG | 150 | 242 | |
| 3 | 2400.000 | 48.04 | 0.88 | 48.92 | 74.00 | -25.08 | peak | 150 | 25 | |
| 4 | 2400.000 | 37.53 | 0.88 | 38.41 | 54.00 | -15.59 | AVG | 150 | 35 | |
| 5 | 2483.500 | 44.93 | 1.10 | 46.03 | 74.00 | -27.97 | peak | 150 | 344 | |
| 6 | 2483.500 | 35.42 | 1.10 | 36.52 | 54.00 | -17.48 | AVG | 150 | 257 | |
| 7 | 2500.000 | 33.51 | 1.10 | 34.61 | 74.00 | -39.39 | peak | 150 | 234 | |
| 8 | 2500.000 | 23.11 | 1.10 | 24.21 | 54.00 | -29.79 | AVG | 150 | 133 | |

Note: Average measurement with peak detection at No.2&4&6&8

12.AC POWER LINE CONDUCTED EMISSION TEST

12.1.Block Diagram of Test Setup

12.1.1.Block diagram of connection between the EUT and simulators

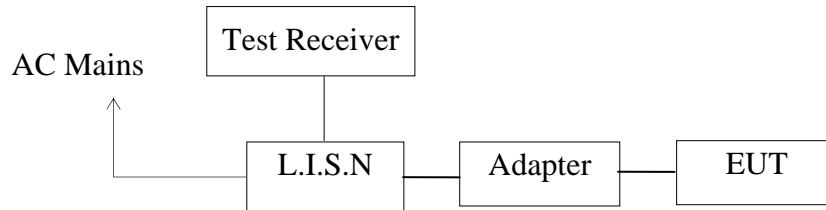

12.1.2.Test System Setup

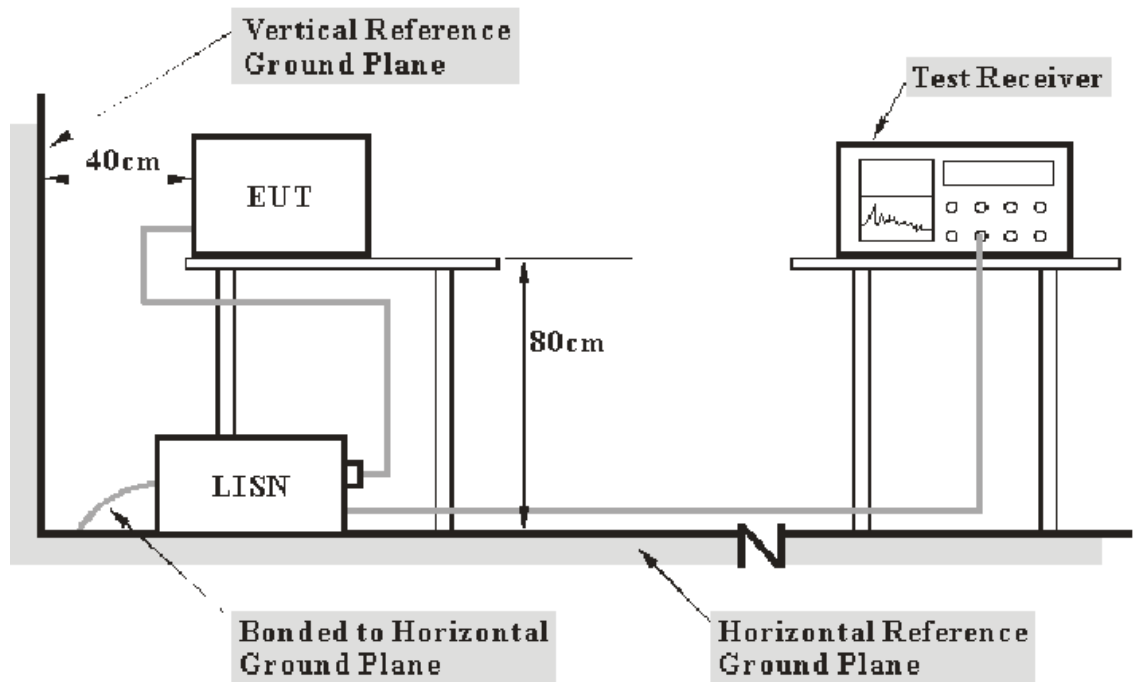

- Note: 1. Support units were connected to second LISN.
2. Both of LISNs (AMN) 80 cm from EUT and at the least 80 cm from other units and other metal planes support units.

12.2. Power Line Conducted Emission Measurement Limits

| Frequency (MHz) | Limit dB(μV) | |
|-----------------|------------------|---------------|
| | Quasi-peak Level | Average Level |
| 0.15 - 0.50 | 66.0 – 56.0 * | 56.0 – 46.0 * |
| 0.50 - 5.00 | 56.0 | 46.0 |
| 5.00 - 30.00 | 60.0 | 50.0 |

NOTE1: The lower limit shall apply at the transition frequencies.
 NOTE2: The limit decreases linearly with the logarithm of the frequency in the range 0.15MHz to 0.50MHz.

12.3. Configuration of EUT on Measurement

The equipments are installed on Power Line Conducted Emission Measurement to meet the commission requirement and operating regulations in a manner, which tends to maximize its emission characteristics in a normal application.

12.4. Operating Condition of EUT

12.4.1. Setup the EUT and simulator as shown as Section 12.1.

12.4.2. Turn on the power of all equipment.

12.4.3. Let the EUT work in test mode and measure it.

12.5. Test Procedure

The EUT is put on the plane 0.8m high above the ground by insulating support and is connected to the power mains through a line impedance stabilization network (L.I.S.N.). This provides a 50ohm coupling impedance for the EUT system. Please refer the block diagram of the test setup and photographs. Both sides of AC lines are checked to find out the maximum conducted emission. In order to find the maximum emission levels, the relative positions of equipment and all of the interface cables shall be changed according to ANSI C63.10: 2013 on Conducted Emission Measurement.

The bandwidth of test receiver is set at 9kHz.

The frequency range from 150kHz to 30MHz is checked.

12.6.Data Sample

| Frequency (MHz) | Transducer value (dB) | QuasiPeak Level (dBμV) | Average Level (dBμV) | QuasiPeak Limit (dBμV) | Average Limit (dBμV) | QuasiPeak Margin (dB) | Average Margin (dB) | Remark (Pass/Fail) |
|-----------------|-----------------------|------------------------|----------------------|------------------------|----------------------|-----------------------|---------------------|--------------------|
| X.XX | 10.6 | 25.3 | 17.0 | 59.0 | 49.0 | 33.4 | 31.7 | Pass |

Frequency(MHz) = Emission frequency in MHz

Transducer value(dB) = Insertion loss of LISN + Cable Loss

Level(dBμV) = Quasi-peak Reading/Average Reading + Transducer value

Limit (dBμV) = Limit stated in standard

Margin = Limit (dBμV) - Level (dBμV)

Calculation Formula:

Margin = Limit (dBμV) - Level (dBμV)

12.7.Test Results

Pass.

Test Lab: 3m Anechoic chamber

The frequency range from 150kHz to 30MHz is checked.

Maximizing procedure was performed on the six (6) highest emissions of the EUT. Emissions attenuated more than 20 dB below the permissible value are not reported.

All data was recorded in the Quasi-peak and average detection mode.

The spectral diagrams are attached as below.

ACCURATE TECHNOLOGY CO., LTD

CONDUCTED EMISSION STANDARD FCC PART 15B

EUT: True Wireless BT Earbuds M/N:CB-TE008
 Manufacturer: CLEVER
 Operating Condition: BT Communication
 Test Site: 1#Shielding Room
 Operator: WADE
 Test Specification: N 120V/60Hz
 Comment: Report No.:ATE20200378
 Start of Test: 5/7/2020 / 8:42:55AM

SCAN TABLE: "V 9K-30MHz fin"

| Start Frequency | Stop Frequency | Step Width | Detector | Meas. Time | IF Bandw. | Transducer |
|-----------------|----------------|------------|-----------|------------|-----------|---------------|
| 9.0 kHz | 150.0 kHz | 100.0 Hz | QuasiPeak | 1.0 s | 200 Hz | NSLK8126 2008 |
| 150.0 kHz | 30.0 MHz | 5.0 kHz | QuasiPeak | 1.0 s | 9 kHz | NSLK8126 2008 |

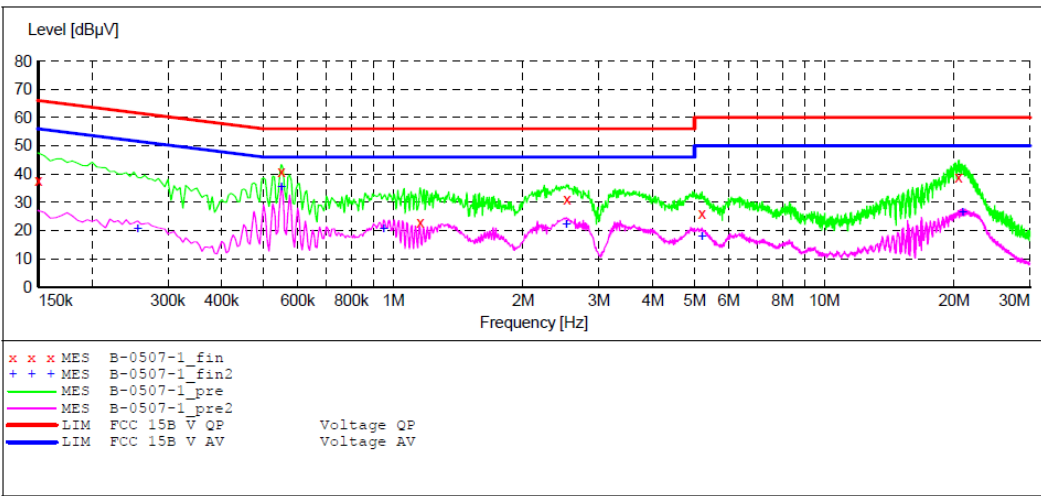

MEASUREMENT RESULT: "B-0507-1_fin"

5/7/2020 8:46AM

| Frequency MHz | Level dBµV | Transd dB | Limit dBµV | Margin dB | Detector | Line | PE |
|---------------|------------|-----------|------------|-----------|----------|------|-----|
| 0.150000 | 37.70 | 10.5 | 66 | 28.3 | QP | N | GND |
| 0.550000 | 40.60 | 10.7 | 56 | 15.4 | QP | N | GND |
| 1.155000 | 22.80 | 10.9 | 56 | 33.2 | QP | N | GND |
| 2.530000 | 31.20 | 11.0 | 56 | 24.8 | QP | N | GND |
| 5.200000 | 26.10 | 11.2 | 60 | 33.9 | QP | N | GND |
| 20.500000 | 39.00 | 11.4 | 60 | 21.0 | QP | N | GND |

MEASUREMENT RESULT: "B-0507-1_fin2"

5/7/2020 8:46AM

| Frequency MHz | Level dBµV | Transd dB | Limit dBµV | Margin dB | Detector | Line | PE |
|---------------|------------|-----------|------------|-----------|----------|------|-----|
| 0.255000 | 20.60 | 10.6 | 52 | 31.0 | AV | N | GND |
| 0.550000 | 35.40 | 10.7 | 46 | 10.6 | AV | N | GND |
| 0.950000 | 20.60 | 10.8 | 46 | 25.4 | AV | N | GND |
| 2.520000 | 22.20 | 11.0 | 46 | 23.8 | AV | N | GND |
| 5.200000 | 17.70 | 11.2 | 50 | 32.3 | AV | N | GND |
| 20.920000 | 26.50 | 11.4 | 50 | 23.5 | AV | N | GND |

ACCURATE TECHNOLOGY CO., LTD

CONDUCTED EMISSION STANDARD FCC PART 15B

EUT: True Wireless BT Earbuds M/N:CB-TE008
 Manufacturer: CLEVER
 Operating Condition: BT Communication
 Test Site: 1#Shielding Room
 Operator: WADE
 Test Specification: L 120V/60Hz
 Comment: Report No.:ATE20200378
 Start of Test: 5/7/2020 / 8:47:01AM

SCAN TABLE: "V 9K-30MHz fin"

| Start Frequency | Stop Frequency | Step Width | Detector | Meas. Time | IF Bandw. | Transducer |
|-----------------|----------------|------------|-----------|------------|-----------|---------------|
| 9.0 kHz | 150.0 kHz | 100.0 Hz | QuasiPeak | 1.0 s | 200 Hz | NSLK8126 2008 |
| 150.0 kHz | 30.0 MHz | 5.0 kHz | QuasiPeak | 1.0 s | 9 kHz | NSLK8126 2008 |

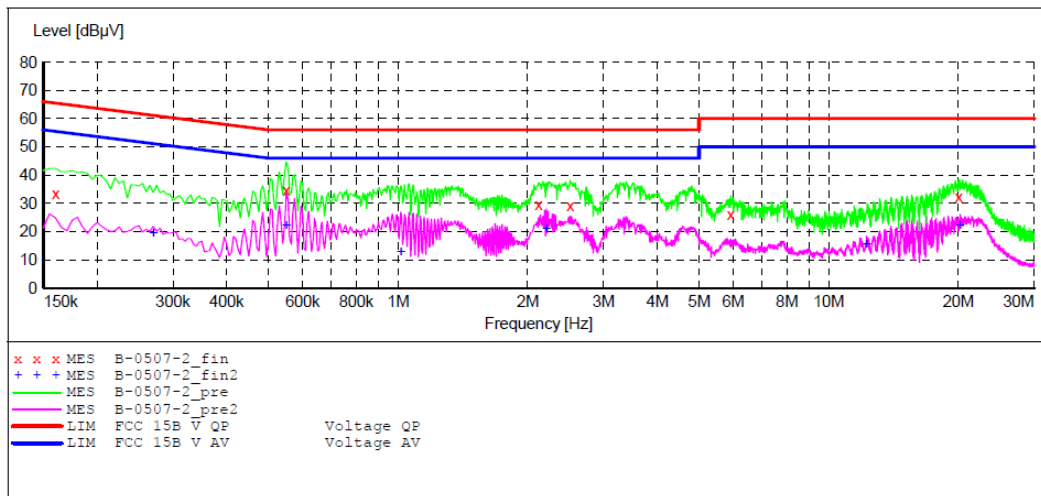

MEASUREMENT RESULT: "B-0507-2_fin"

5/7/2020 8:50AM

| Frequency MHz | Level dBµV | Transd dB | Limit dBµV | Margin dB | Detector | Line | PE |
|---------------|------------|-----------|------------|-----------|----------|------|-----|
| 0.160000 | 33.40 | 10.5 | 66 | 32.1 | QP | L1 | GND |
| 0.550000 | 34.70 | 10.7 | 56 | 21.3 | QP | L1 | GND |
| 2.120000 | 29.50 | 11.0 | 56 | 26.5 | QP | L1 | GND |
| 2.510000 | 29.00 | 11.0 | 56 | 27.0 | QP | L1 | GND |
| 5.920000 | 26.10 | 11.2 | 60 | 33.9 | QP | L1 | GND |
| 20.050000 | 32.30 | 11.4 | 60 | 27.7 | QP | L1 | GND |

MEASUREMENT RESULT: "B-0507-2_fin2"

5/7/2020 8:50AM

| Frequency MHz | Level dBµV | Transd dB | Limit dBµV | Margin dB | Detector | Line | PE |
|---------------|------------|-----------|------------|-----------|----------|------|-----|
| 0.270000 | 19.50 | 10.6 | 51 | 31.6 | AV | L1 | GND |
| 0.550000 | 22.20 | 10.7 | 46 | 23.8 | AV | L1 | GND |
| 1.015000 | 12.90 | 10.8 | 46 | 33.1 | AV | L1 | GND |
| 2.210000 | 21.00 | 11.0 | 46 | 25.0 | AV | L1 | GND |
| 12.250000 | 15.60 | 11.3 | 50 | 34.4 | AV | L1 | GND |
| 20.200000 | 22.00 | 11.4 | 50 | 28.0 | AV | L1 | GND |

13.ANTENNA REQUIREMENT

13.1.The Requirement

According to Section 15.203, an intentional radiator shall be designed to ensure that no antenna other than that furnished by the responsible party shall be used with the device.

13.2.Antenna Construction

Device is equipped with permanent attached antenna, which isn't displaced by other antenna. The Max Antenna gain of EUT is -0.58dBi. Therefore, the equipment complies with the antenna requirement of Section 15.203.

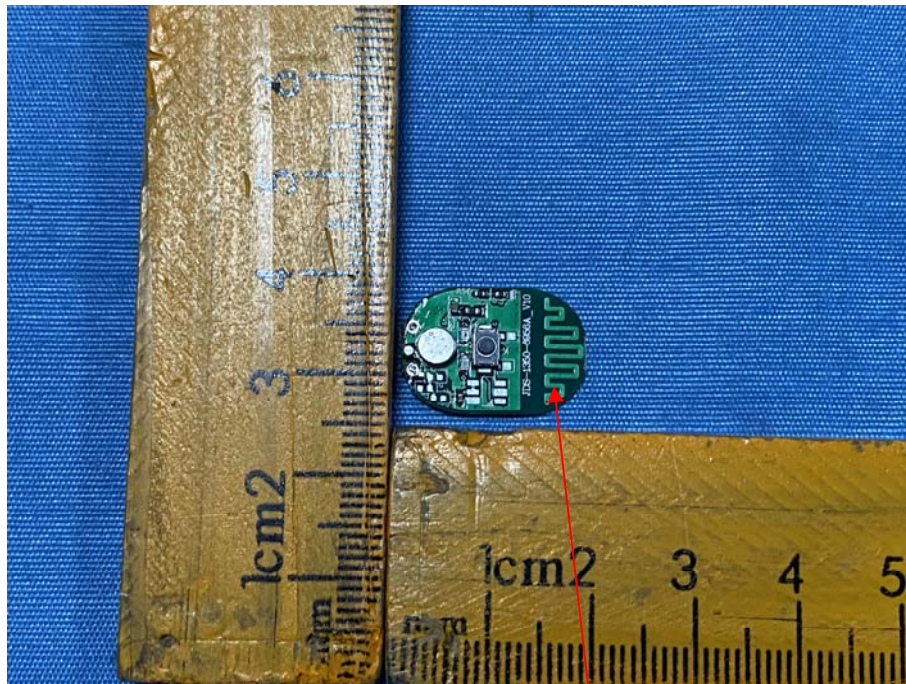

Antenna

***** End of Test Report *****