



# FCC Test Report

## FCC ID: 2AM7T-17946

**Product:** Wireless Charger with 4USB Charger Station

**Trade Name:** N/A

**Model Number:** CB-WU009

**Serial Model:** 4PQW-6/0887,17946,LNST-WC001

**Report No.:** DGE191204004F

**Prepared for**

Good Ever Trading Limited.

Rm.1701,Zhuoyue Building,Fuhua Yi Rd,Futian Central Zone,Shenzhen,P.R.China

**Prepared by**

Shenzhen NTEK Testing Technology Co., Ltd.

1/F, Building E, Fenda Science Park, Sanwei Community, Xixiang Street,  
Bao'an District, Shenzhen P.R. China

Tel.: +86-0755-61156588 Fax.: +86-0755-61156599

Website: [www.ntek.org.cn](http://www.ntek.org.cn)



### TEST RESULT CERTIFICATION

**Applicant's name**..... : Good Ever Trading Limited.  
**Address**..... : Rm.1701,Zhuoyue Building,Fuhua Yi Rd,Futian Central Zone,Shenzhen,P.R.China  
**Manufacturer's Name**..... : SHENZHEN LANNENGSHITONG ELECTRONICS CO.,LTD.  
**Address**..... : Floor 3 No.40 Xinxhe Road Shangmugu village Pinghu Neighborhood Longgang District Shenzhen, Guangdong 518116 CHINA

**Product description**

**Product name**..... : Wireless Charger with 4USB Charger station  
**Model and/or type reference** . : CB-WU009

**Standards**..... : FCC Rules and Regulations Part 15 Subpart C Section 15.207, 15.209, 15.203  
 ANSI C63.10:2013

This device described above has been tested by Shenzhen NTEK Testing Technology Co., Ltd., and the test results show that the equipment under test (EUT) is in compliance with the FCC requirements. And it is applicable only to the tested sample identified in the report.

This report shall not be reproduced except in full, without the written approval of Shenzhen NTEK Testing Technology Co., Ltd., this document may be altered or revised by Shenzhen NTEK Testing Technology Co., Ltd., personnel only, and shall be noted in the revision of the document.

The test results of this report relate only to the tested sample identified in this report.

**Date of Test**..... :  
**Date (s) of performance of tests**..... : 02 Jan.2020 ~ 08 Jan.2020  
**Date of Issue**..... : 26 Feb.2020  
**Test Result**..... : **Pass**

Testing Engineer : Eileen Liu.  
 (Eileen Liu)

Technical Manager : Jason chen  
 (Jason Chen)

Authorized Signatory : Sam. chen  
 (Sam Chen)

<b>Table of Contents</b>	<b>Page</b>
<b>1 . TEST SUMMARY</b>	<b>4</b>
1.1 FACILITIES AND ACCREDITATIONS	5
1.2 LABORATORY ACCREDITATIONS AND LISTINGS	5
1.3 MEASUREMENT UNCERTAINTY	5
<b>2 . GENERAL INFORMATION</b>	<b>7</b>
2.1 GENERAL DESCRIPTION OF EUT	7
2.2 DESCRIPTION OF TEST SETUP	9
2.3 DESCRIPTION TEST PERIPHERAL AND EUT PERIPHERAL	10
2.4 MEASUREMENT INSTRUMENTS LIST	11
<b>3 . EMC EMISSION TEST</b>	<b>12</b>
3.1 CONDUCTED EMISSION MEASUREMENT	12
3.1.1 POWER LINE CONDUCTED EMISSION	12
3.1.2 TEST PROCEDURE	13
3.1.3 TEST SETUP	13
3.1.4 EUT OPERATING CONDITIONS	13
3.1.5 TEST RESULTS	14
3.2 RADIATED EMISSION MEASUREMENT	18
3.2.1 LIMITS OF RADIATED EMISSION MEASUREMENT	18
3.2.2 TEST PROCEDURE	19
3.2.3 TEST SETUP	20
3.2.4 TEST RESULTS	21
<b>4. ANTENNA APPLICATION</b>	<b>26</b>
4.1 Antenna Requirement	26
4.2 Result	26

## . TEST SUMMARY

Test procedures according to the technical standards:

EMC Emission					
Standard	Test Item	FCC Rules	Limit	Judgment	Remark
FCC part 15C ANSI C63.10:2013	Conducted Emission	§15.207	Class B	PASS	
	Radiated Emission	§15.209	Class B	PASS	
	ANTENNA APPLICATION	§15.203	/	PASS	

**NOTE:**

- (1) 'N/A' denotes test is not applicable in this Test Report
- (2) For client's request and manual description, the test will not be executed.

## 1.1 FACILITIES AND ACCREDITATIONS

All measurement facilities used to collect the measurement data are located at 1/F, Building E, Fenda Science Park, Sanwei Community, Xixiang Street, Bao'an District, Shenzhen 518126 P.R. China.

The sites are constructed in conformance with the requirements of ANSI C63.7, ANSI C63.10 and CISPR Publication 22.

## 1.2 LABORATORY ACCREDITATIONS AND LISTINGS

### Site Description

- CNAS-Lab. : The Laboratory has been assessed and proved to be in compliance with CNAS-CL01:2006 (identical to ISO/IEC 17025:2005)  
The Certificate Registration Number is L5516.
- IC-Registration : The Certificate Registration Number is 9270A-1.
- FCC- Accredited : Test Firm Registration Number: 463705.  
Designation Number: CN1184
- A2LA-Lab. : The Certificate Registration Number is 4298.01  
This laboratory is accredited in accordance with the recognized International Standard ISO/IEC 17025:2005 General requirements for the competence of testing and calibration laboratories.  
This accreditation demonstrates technical competence for a defined scope and the operation of a laboratory quality management system (refer to joint ISO-ILAC-IAF Communiqué dated 8 January 2009).
- Name of Firm : Shenzhen NTEK Testing Technology Co., Ltd.
- Site Location : 1/F, Building E, Fenda Science Park, Sanwei Community, Xixiang Street, Bao'an District, Shenzhen 518126 P.R. China.

## 1.3 MEASUREMENT UNCERTAINTY

The reported uncertainty of measurement  $y \pm U$ , where expanded uncertainty  $U$  is based on a standard uncertainty multiplied by a coverage factor of  $k=2$ , providing a level of confidence of approximately **95 %**.

### A. Conducted Measurement :

Test Site	Method	Measurement Frequency Range	U, (dB)	NOTE
NTEKC01	ANSI	150 KHz ~ 30MHz	3.2	

### B. Radiated Measurement :

Test Site	Method	Measurement Frequency Range	U, (dB)	NOTE
NTEKA01	ANSI	30MHz ~ 1000MHz	4.7	
		1GHz ~12.4GHz	5.0	

**Revision History**

Report No.	Version	Description	Issued Date
DGE191204004F	Rev.01	Initial issue of report	08 Jan.2020
DGE191204004F	Rev.02	Second time of report	26 Feb.2020

## GENERAL INFORMATION

### GENERAL DESCRIPTION OF EUT

Product Feature and Specification	
Equipment	Wireless Charger with 4USB Charger station
Trade Name	N/A
FCC ID	2AM7T-17946
Model No.	CB-WU009
Serial Model	4PQW-6/0887,17946,LNST-WC001
Model Difference	All the model are the same circuit and RF module, except the model No. and colour.
Operating Frequency	110KHz~205KHz
Modulation Technique	Induction
Antenna Type	Induction coil
Power supply	<input type="checkbox"/> DC supply: DC 5V from Adapter
	<input checked="" type="checkbox"/> Adapter: Input: 100-240V~ 50/60Hz 0.7A
Output	4 USB Charger Output: 5VDC, 4.1A Max. (total) Wireless Charger Output: 5W Max
HW Version	N/A
SW Version	N/A

## DESCRIPTION OF TEST MODES

### EUT Configuration

The EUT configuration for testing is installed on RF field strength measurement to meet the Commissions requirement and operating in a manner which intends to maximize its emission characteristics in a continuous normal application.

### EUT Exercise

The Transmitter was operated in the normal operating mode. The TX frequency was fixed which was for the purpose of the measurements.

The following summary table is showing all test modes to demonstrate in compliance with the standard.

Test Cases	
Test Item	Data Rate/ Modulation
AC Conducted Emission	Mode 1: Max load*
Radiated Test Cases	Mode 1: Max load

(\*)EUT can only access the specified load, can not adjust the size of the load

Carrier Frequency and Channel list:

Channel	Frequency(MHz)
1	0.110
2	0.157
3	0.205

The EUT supports two voltage inputs and outputs. The EUT performs two voltage mode pretests. Only the worst case of the two voltage modes is recorded in the report.



### DESCRIPTION OF TEST SETUP

RE

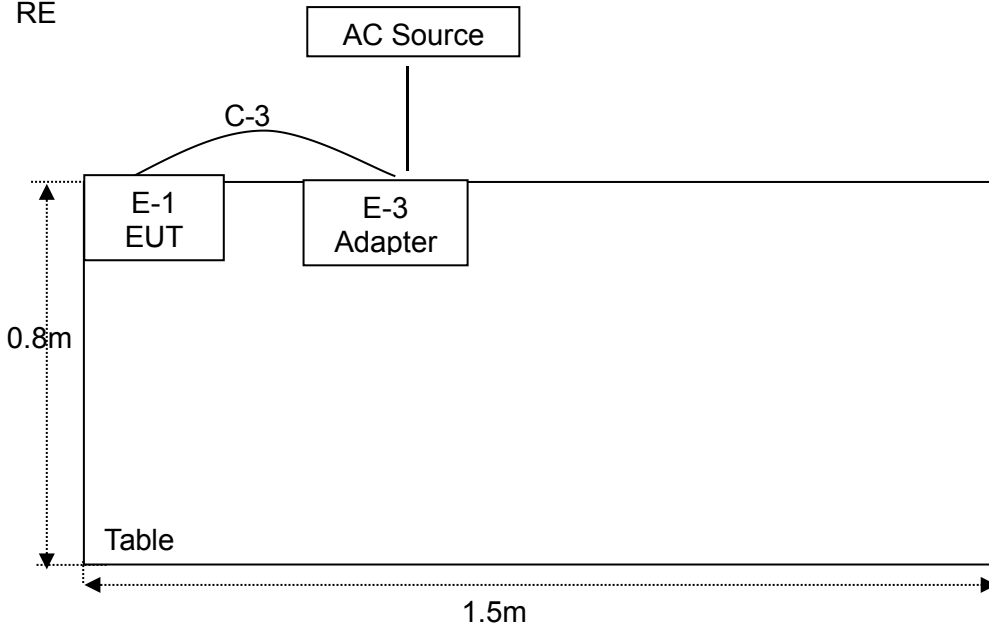

CE

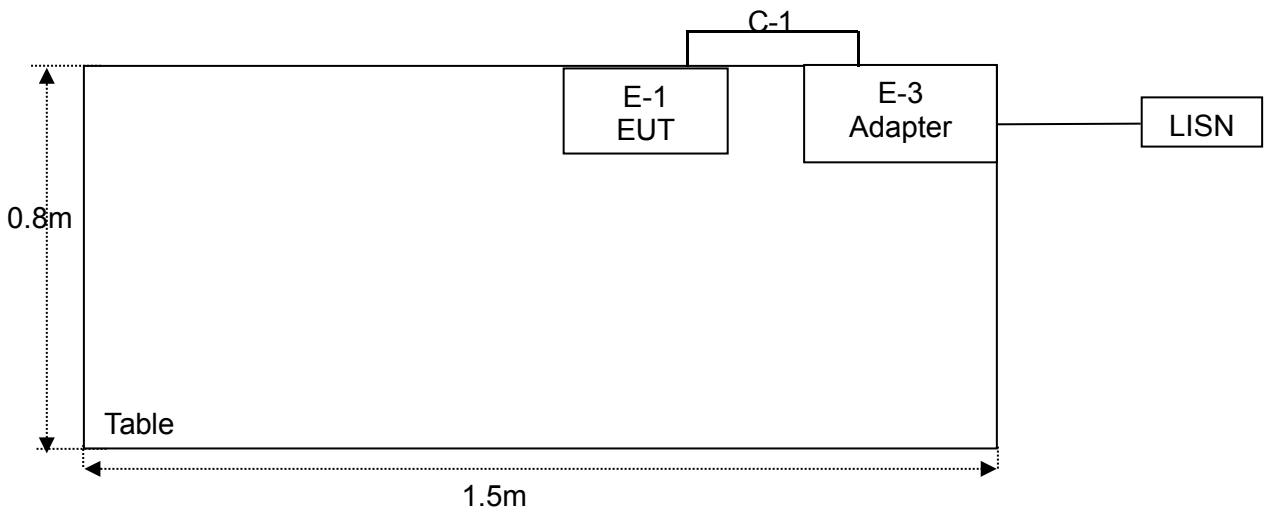

**DESCRIPTION TEST PERIPHERAL AND EUT PERIPHERAL**

The EUT has been tested as an independent unit together with other necessary accessories or support units. The following support units or accessories were used to form a representative test configuration during the tests.

Item	Equipment	Brand	Model/Type No.	Series No.	Note
E-1	Wireless Charger with 4USB Charger Station	N/A	CB-WU009	N/A	EUT
E-2	Power line	N/A	N/A	N/A	
E-3	Load	N/A	N/A	N/A	

Item	Cable Type	Shielded Type	Ferrite Core	Length	Note
C-1	USB Cable	unshielded	NO	1.2m	

**Note:**

- (1) The support equipment was authorized by Declaration of Confirmation.
- (2) For detachable type I/O cable should be specified the length in cm in 『Length』 column.
- (3) “YES” means “shielded” “with core”; “NO” means “unshielded” “without core”.

**MEASUREMENT INSTRUMENTS LIST**
**Radiation Test equipment**

	Kind of Equipment	Manufacturer	Type No.	Serial No.	Last calibration	Calibrated until	Calibration period
1	Spectrum Analyzer	Agilent	E4407B	MY45108040	2019.06.05	2020.06.04	1 year
2	Spectrum Analyzer	Agilent	N9020A	MY49100060	2019.10.26	2020.10.25	1 year
4	Test Receiver	R&S	ESPI	101318	2019.06.05	2020.06.04	1 year
5	Bilog Antenna	TESEQ	CBL6111D	31216	2019.04.08	2020.04.07	1 year
6	50Ω Coaxial Switch	Anritsu	MP59B	6200983705	2019.06.05	2020.06.04	1 year
7	Amplifier	EMC	EMC051835 SE	980246	2019.08.09	2020.08.08	1 year
8	Amplifier	MITEQ	TTA1840-35-HG	177156	2019.06.05	2020.06.04	1 year
9	Loop Antenna	ARA	PLA-1030/B	1029	2019.06.05	2020.06.04	1 year
10	Test Cable (9KHz-30MHz)	N/A	R-01	N/A	2017.04.21	2020.04.20	3 year
11	Test Cable (30MHz-1GHz)	N/A	R-02	N/A	2017.04.21	2020.04.20	3 year

**Conduction Test equipment**

Item	Kind of Equipment	Manufacturer	Type No.	Serial No.	Last calibration	Calibrated until	Calibration period
1	Test Receiver	R&S	ESCI	101160	2019.06.05	2020.06.04	1 year
2	LISN	R&S	ENV216	101313	2019.04.18	2020.04.17	1 year
3	LISN	SCHWARZBECK	NNLK 8129	8129245	2019.06.05	2020.06.04	1 year
4	50Ω Coaxial Switch	ANRITSU CORP	MP59B	6200983704	2019.06.05	2020.06.04	1 year
5	Test Cable (9KHz-30MHz)	N/A	C01	N/A	2017.04.21	2020.04.20	3 year
6	Test Cable (9KHz-30MHz)	N/A	C02	N/A	2017.04.21	2020.04.20	3 year
7	Test Cable (9KHz-30MHz)	N/A	C03	N/A	2017.04.21	2020.04.20	3 year

## EMC EMISSION TEST

### CONDUCTED EMISSION MEASUREMENT

POWER LINE CONDUCTED EMISSION (Frequency Range 150KHz-30MHz)

FREQUENCY (MHz)	limit	
	Quasi-peak	Average
0.15 -0.5	66 - 56 *	56 - 46 *
0.50 -5.0	56.00	46.00
5.0 -30.0	60.00	50.00

Note:

- (1) The tighter limit applies at the band edges.
- (2) The limit of " \* " marked band means the limitation decreases linearly with the logarithm of the frequency in the range.

The following table is the setting of the receiver

Receiver Parameters	Setting
Attenuation	10 dB
Start Frequency	0.15 MHz
Stop Frequency	30 MHz
IF Bandwidth	9 kHz

TEST PROCEDURE

- a. The EUT was placed 0.8 meters from the horizontal ground plane with EUT being connected to the power mains through a line impedance stabilization network (LISN). All other support equipments powered from additional LISN(s). The LISN provide 50 Ohm/ 50uH of coupling impedance for the measuring instrument.
- b. Interconnecting cables that hang closer than 40 cm to the ground plane shall be folded back and forth in the center forming a bundle 30 to 40 cm long.
- c. I/O cables that are not connected to a peripheral shall be bundled in the center. The end of the cable may be terminated, if required, using the correct terminating impedance. The overall length shall not exceed 1 m.
- d. LISN at least 80 cm from nearest part of EUT chassis.
- e. For the actual test configuration, please refer to the related Item –EUT Test Photos.

TEST SETUP

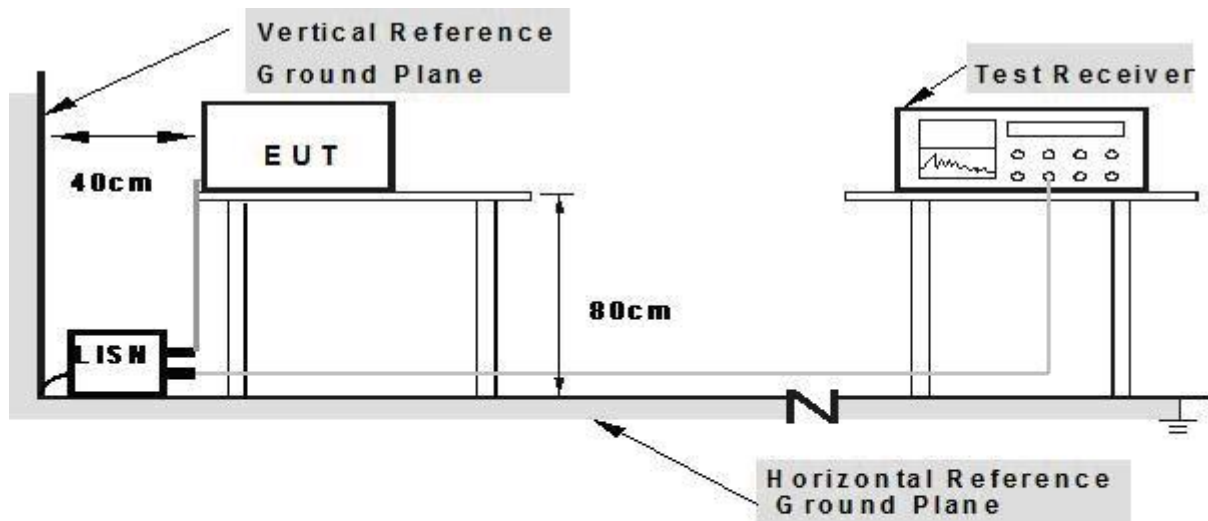

- Note: 1. Support units were connected to second LISN.**  
**2. Both of LISNs (AMN) are 80 cm from EUT and at least 80 from other units and other metal planes**

EUT OPERATING CONDITIONS

The EUT tested system was configured as the statements of 2.3 Unless otherwise a special operating condition is specified in the follows during the testing.

## TEST RESULTS

EUT:	Wireless Charger with 4USB Charger station	Model Name. :	CB-WU009
Temperature:	26 °C	Relative Humidity:	54%
Pressure:	1010hPa	Test Date:	2020-01-05
Test Mode:	Mode 1(Mid frequency)	Phase :	L
Test Voltage:	Output: DC 5V,Input: Adapter AC 120V/60Hz		

Frequency (MHz)	Reading Level (dB $\mu$ V)	Correct Factor (dB)	Measure-ment (dB $\mu$ V)	Limits (dB $\mu$ V)	Margin (dB)	Remark
0.1794	32.84	9.91	42.75	64.51	-21.76	QP
0.1794	12.25	9.91	22.16	54.51	-32.35	AVG
0.2234	29.08	9.90	38.98	62.69	-23.71	QP
0.2234	10.09	9.90	19.99	52.69	-32.70	AVG
23.3745	26.31	12.92	39.23	60.00	-20.77	QP
23.3728	7.70	12.92	20.62	50.00	-29.38	AVG

Remark:

1. All readings are Quasi-Peak and Average values.
2. Factor = Insertion Loss + Cable Loss.

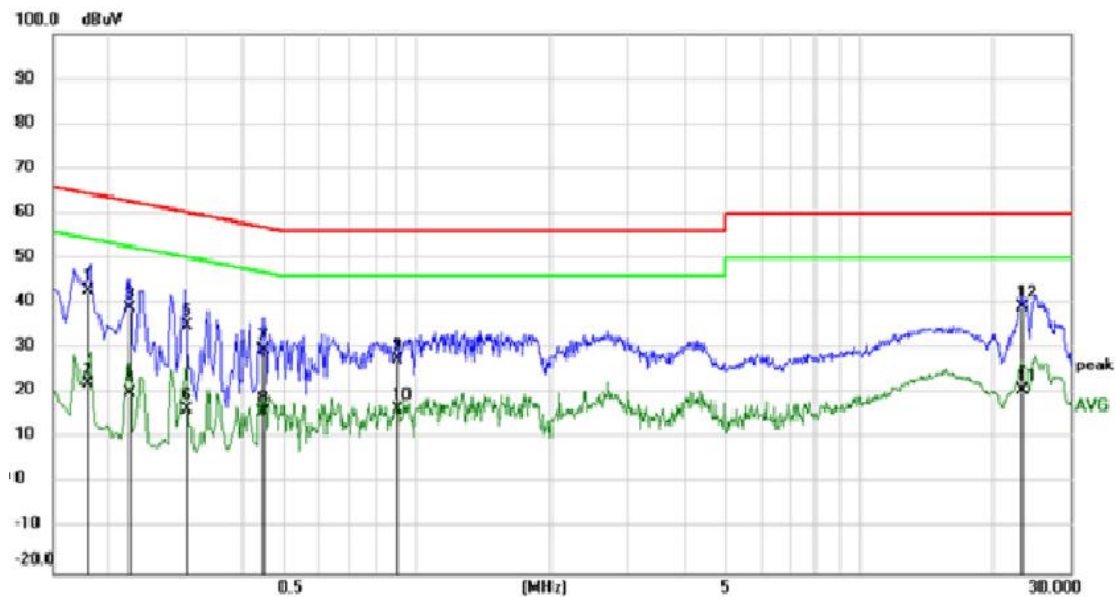

EUT:	Wireless Charger with 4USB Charger station	Model Name. :	CB-WU009
Temperature:	26 °C	Relative Humidity:	54%
Pressure:	1010hPa	Test Date:	2020-01-05
Test Mode:	Mode 1(Mid frequency)	Phase :	N
Test Voltage:	Output: DC 5V,Input: Adapter AC 120V/60Hz		

Frequency (MHz)	Reading Level (dB $\mu$ V)	Correct Factor (dB)	Measure-ment (dB $\mu$ V)	Limits (dB $\mu$ V)	Margin (dB)	Remark
0.1724	37.19	9.93	47.12	64.84	-17.72	QP
0.1724	17.59	9.93	27.52	54.84	-27.32	AVG
0.4691	20.11	9.94	30.05	56.53	-26.48	QP
0.4691	3.17	9.94	13.11	46.53	-33.42	AVG
1.7967	20.43	10.02	30.45	56.00	-25.55	QP
1.7967	8.27	10.02	18.29	46.00	-27.71	AVG

\Remark:

1. All readings are Quasi-Peak and Average values.
2. Factor = Insertion Loss + Cable Loss.

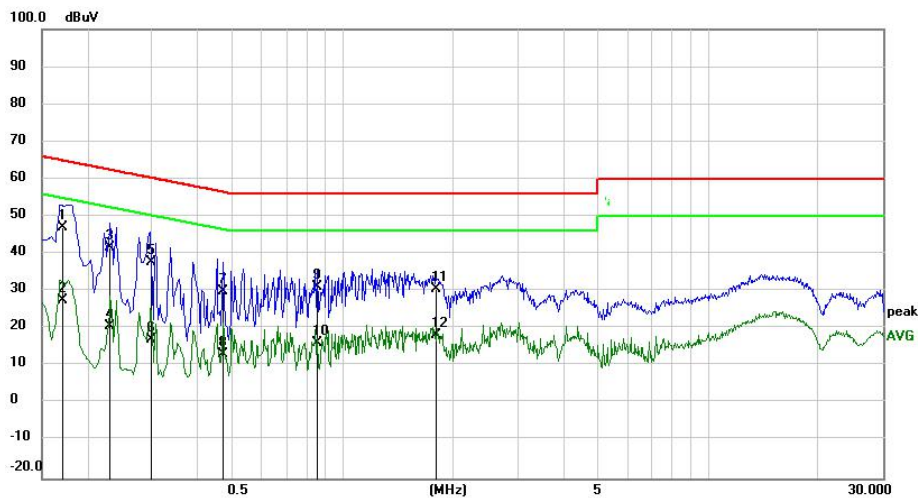

EUT:	Wireless Charger with 4USB Charger station	Model Name. :	CB-WU009
Temperature:	26 °C	Relative Humidity:	54%
Pressure:	1010hPa	Test Date:	2020-01-05
Test Mode:	Mode 1(Mid frequency)	Phase :	L
Test Voltage:	Output: DC 5V,Input: Adapter AC 240V/60Hz		

No.	Mk.	Freq. MHz	Reading Level dBuV	Correct Factor dB	Measure- ment dBuV	Limit dBuV	Over dB	Detector	Comment
1		0.1725	15.24	9.93	25.17	54.84	-29.67	AVG	
2		0.4875	10.12	9.93	20.05	46.21	-26.16	AVG	
3	*	0.4965	24.86	9.93	34.79	56.06	-21.27	peak	
4		0.8835	5.19	9.97	15.16	46.00	-30.84	AVG	
5		2.1210	19.36	10.04	29.40	56.00	-26.60	peak	
6		2.1210	13.06	10.04	23.10	46.00	-22.90	AVG	
7		4.2495	17.78	10.21	27.99	56.00	-28.01	peak	
8		4.9560	18.75	10.27	29.02	56.00	-26.98	peak	
9		19.6350	13.83	13.06	26.89	60.00	-33.11	peak	
10		19.6350	8.12	13.06	21.18	50.00	-28.82	AVG	
11		23.8785	5.73	12.89	18.62	50.00	-31.38	AVG	
12		26.8620	15.86	12.71	28.57	60.00	-31.43	peak	

## Remark:

1. All readings are Quasi-Peak and Average values.
2. Factor = Insertion Loss + Cable Loss.

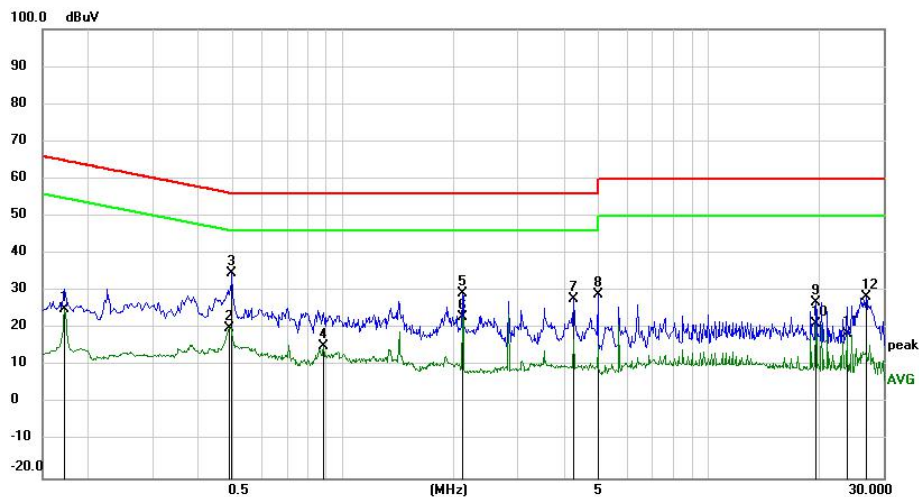



EUT:	Wireless Charger with 4USB Charger station	Model Name. :	CB-WU009
Temperature:	26 °C	Relative Humidity:	54%
Pressure:	1010hPa	Test Date:	2020-01-05
Test Mode:	Mode 1(Mid frequency)	Phase :	N
Test Voltage:	Output: DC 5V,Input: Adapter AC 240V/60Hz		

No.	Mk.	Freq. MHz	Reading Level dBuV	Correct Factor dB	Measure- ment dBuV	Limit dBuV	Over dB	Detector	Comment
1		0.1770	17.60	9.91	27.51	64.63	-37.12	QP	
2		0.1770	14.15	9.91	24.06	54.63	-30.57	AVG	
3		0.4920	14.67	9.94	24.61	56.13	-31.52	QP	
4		0.4920	4.66	9.94	14.60	46.13	-31.53	AVG	
5		1.1580	14.64	9.98	24.62	56.00	-31.38	QP	
6		3.0075	12.51	10.11	22.62	56.00	-33.38	QP	
7		3.7140	15.45	10.17	25.62	56.00	-30.38	QP	
8	*	3.7140	14.44	10.17	24.61	46.00	-21.39	AVG	
9		7.6065	15.01	10.61	25.62	60.00	-34.38	QP	
10		7.9620	15.06	10.66	25.72	50.00	-24.28	AVG	
11		11.4990	11.20	11.27	22.47	50.00	-27.53	AVG	
12		19.6395	5.44	12.75	18.19	50.00	-31.81	AVG	

Remark:

1. All readings are Quasi-Peak and Average values.
2. Factor = Insertion Loss + Cable Loss.

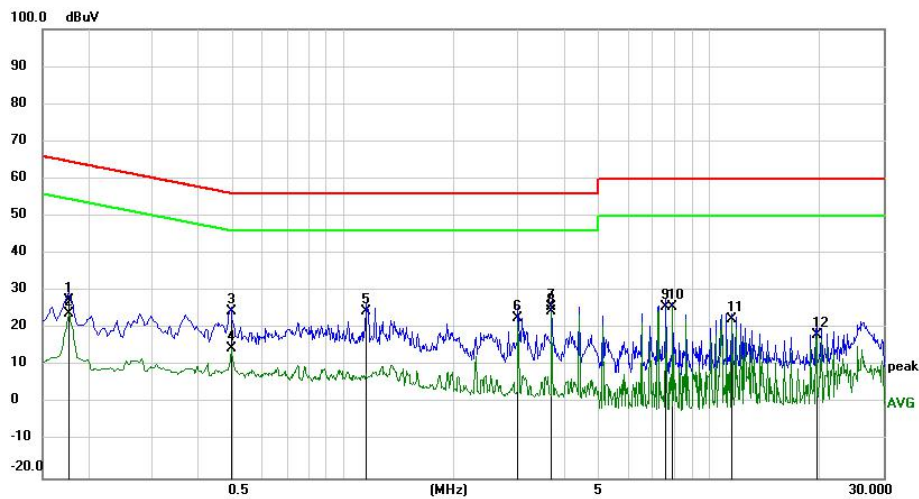

## RADIATED EMISSION MEASUREMENT

### LIMITS OF RADIATED EMISSION MEASUREMENT

The emissions from an intentional radiator shall not exceed the field strength levels specified in the following table 15.209(a):

Frequency (MHz)	Field strength (microvolts/meter)	Measurement distance (meters)
0.009-0.490	2400/F(kHz)	300
0.490-1.705	24000/F(kHz)	30
1.705-30.0	30	30
30-88	100**	3
88-216	150**	3
216-960	200**	3
Above 960	500	3

### 15.205 Restricted bands of operation

MHz	MHz	MHz	GHz
0.090-0.110	16.42-16.423	399.9-410	4.5-5.15
<sup>1</sup> 0.495-0.505	16.69475-16.69525	608-614	5.35-5.46
2.1735-2.1905	16.80425-16.80475	960-1240	7.25-7.75
4.125-4.128	25.5-25.67	1300-1427	8.025-8.5
4.17725-4.17775	37.5-38.25	1435-1626.5	9.0-9.2
4.20725-4.20775	73-74.6	1645.5-1646.5	9.3-9.5
6.215-6.218	74.8-75.2	1660-1710	10.6-12.7
6.26775-6.26825	108-121.94	1718.8-1722.2	13.25-13.4
6.31175-6.31225	123-138	2200-2300	14.47-14.5
8.291-8.294	149.9-150.05	2310-2390	15.35-16.2
8.362-8.366	156.52475-156.52525	2483.5-2500	17.7-21.4
8.37625-8.38675	156.7-156.9	2690-2900	22.01-23.12
8.41425-8.41475	162.0125-167.17	3260-3267	23.6-24.0
12.29-12.293	167.72-173.2	3332-3339	31.2-31.8
12.51975-12.52025	240-285	3345.8-3358	36.43-36.5
12.57675-12.57725	322-335.4	3600-4400	( <sup>2</sup> )
13.36-13.41			

#### Notes:

- (1) Measurement was performed at an antenna to the closed point of EUT distance of meters.
- (2) Emission level (dBuV/m)=20log Emission level (uV/m).
- (3) Only spurious frequency is permitted to locate within the Restricted Bands specified in provision of 15.205, and the emissions located in restricted bands also comply with 15.209 limit.
- (4) The emission limits shown in the above table are based on measurements employing a CISPR quasi-peak detector except for the frequency bands 9-90 kHz, 110-490 kHz and above 1000 MHz. Radiated emission limits in these three bands are based on measurements employing an average detector

## TEST PROCEDURE

### Test Arrangement for Radiated Emissions up to 1 GHz

- a. The EUT was placed on the top of a rotating table 0.8 meters above the ground at an accredited test facility. The table was rotated 360 degrees to determine the position of the highest radiation.
- b. The EUT was set 3 meters away from the interference-receiving antenna, which was mounted on the top of a variable-height antenna tower.
- c. The antenna is a broadband antenna (Blow 30M, use loop antenna), and its height is varied from one meter to four meters above the ground to determine the maximum value of the field strength. Both horizontal and vertical polarizations of the antenna are set to make the measurement.
- d. For each suspected emission, the EUT was arranged to its worst case and then the antenna was tuned to heights from 1 meter to 4 meters and the rotatable table was turned from 0 degrees to 360 degrees to find the maximum reading.

Note: The resolution bandwidth and video bandwidth of test receiver/spectrum analyzer is 120kHz for quasi-peak detection (QP) at frequency below 1GHz.

### Test Arrangement for Radiated Emissions above 1 GHz.

- a. The EUT was placed on the top of a rotating table 0.8 meters above the ground at an accredited chamber room. The table was rotated 360 degrees to determine the position of the highest radiation.
- b. The EUT was set 3 meters away from the interference-receiving antenna, which was mounted on the top of a variable-height antenna tower.
- c. The height of antenna can be varied from one meter to four meters, the height of adjustment depends on the EUT height and the antenna 3dB beamwidth both, to detect the maximum value of the field strength. Both horizontal and vertical polarizations of the antenna are set to make the measurement.
- d. For each suspected emission, the EUT was arranged to its worst case and then the antenna was tuned to heights and the rotatable table was turned from 0 degrees to 360 degrees to find the maximum reading.

During the radiated emission test, the Spectrum Analyzer was set with the following configurations:

Use the following receiver/spectrum analyzer settings:

Span = wide enough to fully capture the emission being measured

RBW=200Hz for 9KHz to 150KHz,

RBW=9kHz for 150KHz to 30MHz,

RBW=120KHz for 30MHz to 1GHz

VBW  $\geq$  3\*RBW

Sweep = auto

Detector function = QP

Trace = max hold

**TEST SETUP**

For Radiated Emission Test Set-Up, Frequency Below 30MHz

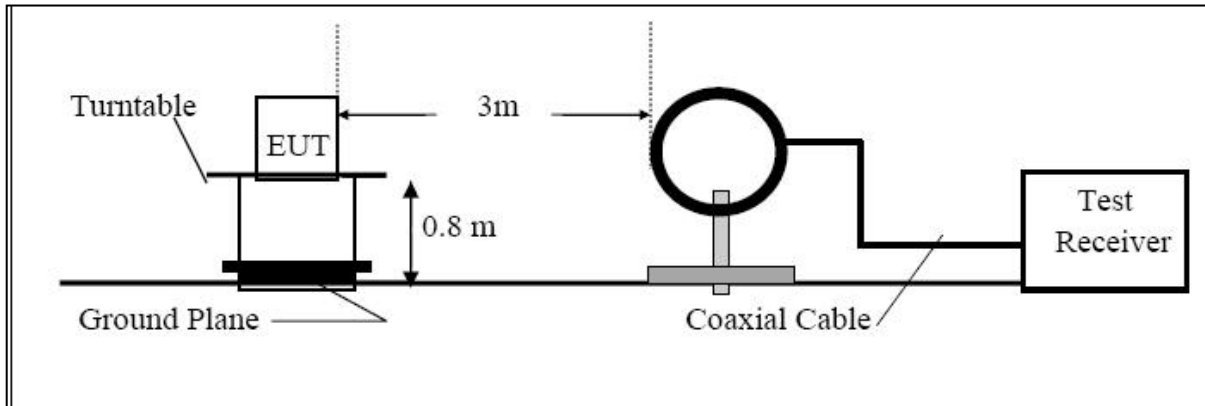

For Radiated Emission 30~1000MHz

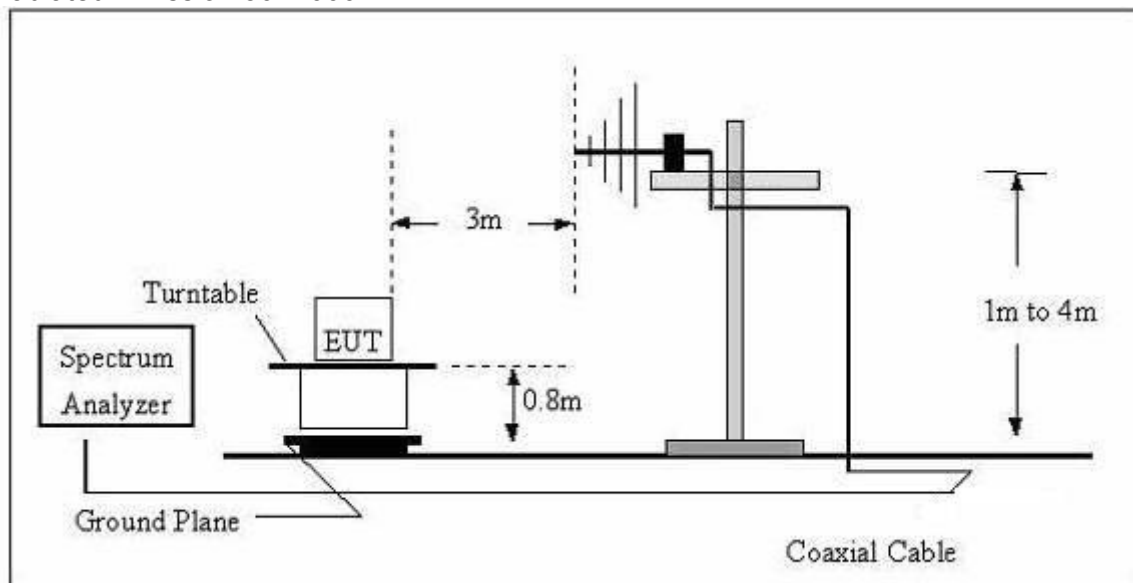

**TEST RESULTS**
**TEST RESULTS (9KHz~30MHz)**

EUT:	Wireless Charger with 4USB Charger station	Model Name. :	CB-WU009
Temperature:	24 °C	Relative Humidity:	54%
Pressure:	1010 hPa	Test Date :	2020-01-05
Test Mode :	Low frequency/Max Load	Polarization :	X
Test Power :	Output: DC 5V,Input: Adapter AC 120V/60Hz		

Frequency (MHz)	Ant.Pol.	Emission Level (dBuV/m)	Limits (dBuV/m)	Margin (dB)	Remark
0.040	X	45.97	115.541	-69.57	Avg
0.110	X	62.38	106.776	-44.40	Avg(fundamental frequency)
0.797	X	46.370	69.575	-23.21	QP
3.402	X	41.275	56.969	-15.69	QP
7.271	X	43.014	69.542	-26.53	QP
20.593	X	36.870	69.542	-32.67	QP

**Note:**

Below 30MHz, Pre-test the X, Y, Z axis to find X axis is worst case, so only record X axis test data.

X: Field strength which this device generates since the position of the charging coil and loop antenna differ by 0 degrees.

Y: Field strength which this device generates since the position of the charging coil and loop antenna differ by 90 degrees.

Z: Field strength which this device generates since the position of the charging coil and loop antenna differ by 180 degrees.

EUT:	Wireless Charger with 4USB Charger station	Model Name. :	CB-WU009
Temperature:	24 °C	Relative Humidity:	54%
Pressure:	1010 hPa	Test Date :	2020-01-05
Test Mode :	Mid frequency/Max Load	Polarization :	X
Test Power :	Output: DC 5V,Input: Adapter AC 120V/60Hz		

Frequency (MHz)	Ant.Pol.	Emission Level (dBuV/m)	Limits (dBuV/m)	Margin (dB)	Remark
0.043	X	41.51	114.9349	-73.42	Avg
0.157	X	77.02	103.6862	-26.67	Avg(fundamental frequency)
0.679	X	38.490	70.967	-32.48	QP
1.228	X	33.592	65.820	-32.23	QP
5.283	X	32.891	69.542	-36.65	QP
9.270	X	44.235	69.542	-25.31	QP

Note:

Below 30MHz, Pre-test the X, Y, Z axis to find X axis is worst case, so only record X axis test data.

X: Field strength which this device generates since the position of the charging coil and loop antenna differ by 0 degrees.

Y: Field strength which this device generates since the position of the charging coil and loop antenna differ by 90 degrees.

Z: Field strength which this device generates since the position of the charging coil and loop antenna differ by 180 degrees.

EUT:	Wireless Charger with 4USB Charger station	Model Name. :	CB-WU009
Temperature:	24 °C	Relative Humidity:	54%
Pressure:	1010 hPa	Test Date :	2020-01-05
Test Mode :	High frequency/Max Load	Polarization :	X
Test Power :	Output: DC 5V,Input: Adapter AC 120V/60Hz		

Frequency y (MHz)	Ant.Pol.	Emission Level (dBuV/m)	Limits (dBuV/m)	Margin (dB)	Remark
0.050	X	43.022	113.6248	-70.60	Avg
0.205	X	79.65	101.3691	-21.72	Avg(fundamental frequency)
0.500	X	43.322	73.625	-30.30	QP
2.319	X	35.983	60.298	-24.32	QP
6.227	X	35.270	69.542	-34.27	QP
10.291	X	32.761	69.542	-36.78	QP

Note:

Below 30MHz, Pre-test the X, Y, Z axis to find X axis is worst case, so only record X axis test data.

X: Field strength which this device generates since the position of the charging coil and loop antenna differ by 0 degrees.

Y: Field strength which this device generates since the position of the charging coil and loop antenna differ by 90 degrees.

Z: Field strength which this device generates since the position of the charging coil and loop antenna differ by 180 degrees.



**TEST RESULTS (30MHz ~1000MHz)**

EUT:	Wireless Charger with 4USB Charger station	Model Name. :	CB-WU009
Temperature:	24 °C	Relative Humidity:	54%
Pressure:	1010 hPa	Test Date :	2020-01-05
Test Mode :	High frequency/Max Load	Polarization :	Horizontal
Test Power :	Output: DC 5V,Input: Adapter AC 120V/60Hz		

No.	Mk.	Freq. MHz	Reading Level dBuV	Correct Factor dB	Measure- ment dBuV/m	Limit dB/m	Over dB	Detector	Antenna Height cm	Table Degree degree	Comment
1		31.0706	46.03	-20.43	25.60	40.00	-14.40	QP			
2	*	35.8746	50.22	-23.47	26.75	40.00	-13.25	QP			
3		111.3468	50.37	-25.31	25.06	43.50	-18.44	QP			
4		210.7860	48.89	-26.40	22.49	43.50	-21.01	QP			
5		252.0627	55.11	-24.96	30.15	46.00	-15.85	QP			
6		327.8873	49.48	-23.01	26.47	46.00	-19.53	QP			

Remark:

Factor = Antenna Factor + Cable Loss - Amplifier.





EUT:	Wireless Charger with 4USB Charger station	Model Name. :	CB-WU009
Temperature:	24 °C	Relative Humidity:	54%
Pressure:	1010 hPa	Test Date :	2020-01-05
Test Mode :	High frequency/Max Load	Polarization :	Vertical
Test Power :	Output: DC 5V,Input: Adapter AC 120V/60Hz		

No. Mk.	Freq. MHz	Reading Level dBuV	Correct Factor dB	Measure- ment dBuV/m	Limit dB/m	Over dB	Detector	Antenna Height cm	Table Degree	Comment
1 *	35.3750	53.63	-23.59	30.04	40.00	-9.96	QP			
2	39.8542	53.46	-24.82	28.64	40.00	-11.36	QP			
3	45.5348	54.75	-26.82	27.93	40.00	-12.07	QP			
4	80.0806	54.56	-29.08	25.48	40.00	-14.52	QP			
5	175.6516	50.58	-26.09	24.49	43.50	-19.01	QP			
6	264.7457	51.17	-24.25	26.92	46.00	-19.08	QP			

Remark:

Factor = Antenna Factor + Cable Loss - Amplifier.

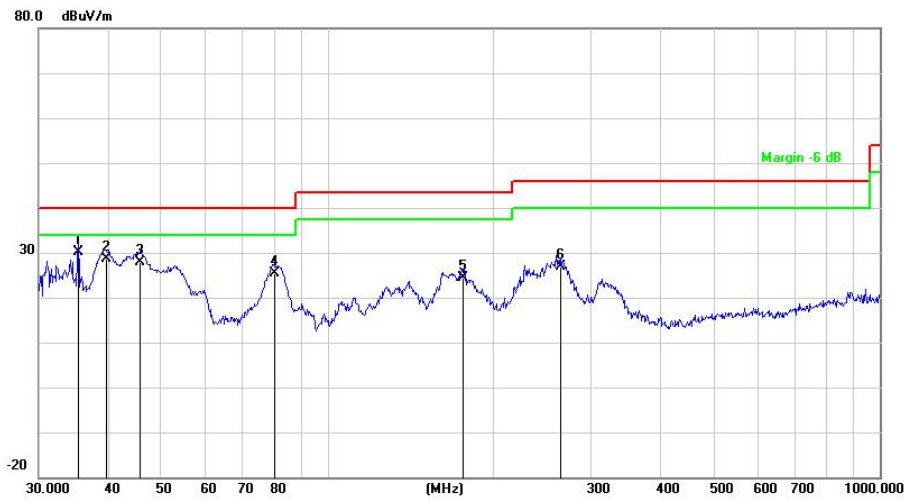

#### **4. ANTENNA APPLICATION**

##### **4.1 Antenna Requirement**

15.203 requirement: For intentional device, according to 15.203: an intentional radiator shall be designed to ensure that no antenna other than that furnished by the responsible party shall be used with the device.

##### **4.2 Result**

The EUT antenna is permanent attached antenna. It comply with the standard requirement.

END REPORT