



UL LLC
12 Laboratory Dr.
Research Triangle Park, NC 27709
(919) 549-1400

Report Number: R11694639-E7
Order Number: 11694639
Date: 2018-06-04
Model: M2001
FCC ID: 2AM5NM2000
IC ID: 23045-M2000

Electromagnetic Compatibility Certification Report

For

MAGIC LEAP, INC.
7500 WEST SUNRISE BOULEVARD
PLANTATION, FL 33322, USA

Copyright © 2018 UL LLC

UL LLC authorizes the above-named company to reproduce this Report provided it is reproduced in its entirety.

Report Directory

1.0	GENERAL - Product Description.....	4
1.1	Equipment Description	4
1.2	Equipment Marking Plate	4
1.3	Device Configuration During Test.....	5
1.3.1	Equipment Used During Test:	5
1.3.2	Input/Output Ports:.....	5
1.3.3	EUT Internal Operating Frequencies:	5
1.3.4	Power Interface:.....	5
1.4	Block Diagram:.....	6
1.5	EUT Configurations.....	6
1.6	EUT Operation Modes.....	6
1.7	Rationale for EUT Configuration.....	6
2.0	Summary	7
2.1	Deviations from standard test methods.....	7
2.2	Device Modifications Necessary for Compliance.....	7
2.3	Reference Standards	7
2.4	Results Summary.....	7
3.0	Calibration of Equipment Used for Measurement.....	8
4.0	EMISSIONS TEST RESULTS	8
4.1	Test Conditions and Results – MAINS TERMINAL – CONDUCTED EMISSIONS	9
4.2	Test Conditions and Results – RADIATED EMISSIONS	14
Appendix A	20
	Accreditations and Authorizations	20

Report Revision History

Revision Date	Description	Revised By
2018-06-04	Removed test setup photos and place into separate report. Revised model to M2001. Revised product type description in Section 1.3.1 Revised power supply manufacturer in Section 1.3.1	Brian T. Kiewra
2018-06-25	Added explanation of worst case orientation exploration.	Niklas Haydon

1.0 GENERAL - Product Description

1.1 Equipment Description

Magic Leap One – Control with 2.4GHz proprietary radio (BLE) and EM transmitter

1.2 Equipment Marking Plate

None

1.3 Device Configuration During Test

1.3.1 Equipment Used During Test:

Use	Product Type	Manufacturer	Model	Comments
EUT	Magic Leap One Control with 2.4G Proprietary Radio (BLE) and EM transmitter	Magic Leap	M2001	None
AE	Power Supply	Salcomp	M3001	15W
AE	Power Supply	Salcomp	M3002	45W

Note: EUT - Equipment Under Test, AE - Auxiliary/Associated Equipment, or SIM - Simulator (Not Subjected to Test)

1.3.2 Input/Output Ports:

Port #	Name	Type*	Cable Max. >3m (Y/N)	Cable Shielded (Y/N)	Comments
0	Enclosure	N/E	—	—	None
1	USB-C	I/O, DC	<3m	Y	None

Note:
 AC = AC Power Port DC = DC Power Port N/E = Non-Electrical
 I/O = Signal Input or Output Port (Not Involved in Process Control)
 TP = Telecommunication Ports

1.3.3 EUT Internal Operating Frequencies:

Frequency (MHz)	Description
2478	Highest Tx frequency

1.3.4 Power Interface:

Mode # /Rated	Voltage (V)	Current (A)	Power (W)	Frequency (DC/AC-Hz)	Phases (#)	Comments
Rated	100-240	-	-	50-60	1	None
1	120	-	-	60	1	North America

1.4 Block Diagram:

The diagram below illustrates the configuration of the equipment above.

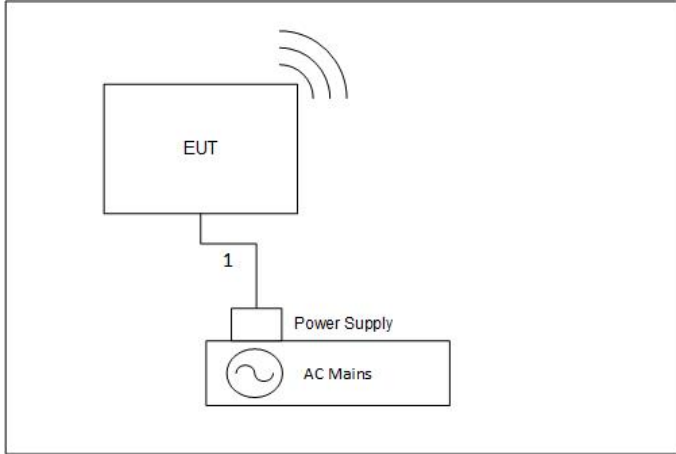

1.5 EUT Configurations

Mode #	Description
1	The EUT was configured as table top equipment.

1.6 EUT Operation Modes

Mode #	Description
1	Operating as intended.

1.7 Rational for EUT Configuration

Mode #	Description
1	The selected EUT configuration was chosen to maximize emissions

2.0 Summary

The tests listed in the Results Summary section of this report have been performed and the results recorded by UL LLC in accordance with the procedures stated in each test requirement and specification. The applicant determined the list of tests performed were applicable to the Equipment Under Test. As a result, the subject product has been verified to comply or not comply as noted in the Summary of Testing with each test specification. The test results relate only to the items tested.

2.1 Deviations from standard test methods

None

2.2 Device Modifications Necessary for Compliance

None

2.3 Reference Standards

Standard Number	Standard Name	Standard Date
47 CFR Part 15, Subpart B	Radio Frequency Devices – Unintentional Radiators	2018
ICES-003	Information Technology Equipment (ITE) — Limits and methods of measurement	2016

2.4 Results Summary

This product is considered Class B.

Requirement – Test	Result (Compliant / Non-Compliant)
Conducted Emissions - Mains	Compliant
Radiated Emissions	Compliant

Test Engineer:



Brian T. Kiewra
Project Engineer
UL – Consumer Technology Division

Reviewer:



Jeffrey Moser
Operations Leader
UL – Consumer Technology Division

Any information and documentation involving UL Mark services are provided on behalf of UL LLC (UL) or any authorized licensee of UL.

3.0 Calibration of Equipment Used for Measurement

All test equipment and test accessories are calibrated on a regular basis. The maximum time between calibrations is one year or the manufacturers' recommendation, whichever is less.

All test equipment calibrations are traceable to the National Institute of Standards and Technology (NIST); therefore, all test data recorded in this report is traceable to NIST.

4.0 EMISSIONS TEST RESULTS

The emissions tests were performed according to following regulations:

----- United States -----

Code of Federal Regulations Title 47	Part 15, Subpart B, Radio Frequency Devices
--------------------------------------	---

Unless specified otherwise in the individual Methods, the tests shall be conducted under the following ambient conditions. Confirmation of these conditions shall be verified at the time the test is conducted.

Ambient Temperature, °C	22.5 ± 2.5	Relative Humidity, %	45 ± 15	Barometric Pressure, mBar	950 ± 150
-------------------------	------------	----------------------	---------	---------------------------	-----------

Measurement Uncertainty

Test	Uncertainty
Conducted Emissions (0.150-30MHz)	+/- 2.94 dB
Radiated Emissions (30-18 GHz)	+/- 5.36 dB

Note – The above values represent worst-case for each frequency range.

Sample Calculations

Radiated Field Strength and Conducted Emissions data contained within this report is calculated on the following basis:

- Field Strength (dBuV/m) = Meter Reading (dBuV) + AF (dB/m) - Gain (dB) + Cable Loss (dB)
- Conducted Voltage (dBuV) = Meter Reading (dBuV) + Cable Loss (dB) + LISN IL (dB)
- Conducted Current (dBuA) = Meter Reading (dBuV) + Cable Loss (dB) - Transducer Factor (dBohms)

4.1 Test Conditions and Results – MAINS TERMINAL – CONDUCTED EMISSIONS

Test Description	Measurements were made on a ground plane. All power was connected to the system through Artificial Mains Network (AMN). Conducted voltage measurements on mains lines were made at the output of the AMN.	
Basic Standard	FCC Part 15, Subparts A & B in conjunction with ANSI C63.4:2014	
UL LPG	80-EM-S0026	
	Frequency range on each side of line	Measurement Point
Fully configured sample scanned over the following frequency range	150kHz to 30MHz	Mains
Limits - Class B		
Frequency (MHz)	Limit (dB μ V)	
	Quasi-Peak	Average
0.15-0.5	66 to 56	56 to 46
0.5-5	56	46
5-30	60	50

Table 1 Conducted Emissions EUT Configuration Settings

Power Interface Mode #	EUT Configurations Mode #	EUT Operation Mode #
1 (120V/60Hz)	1	1

Table 2 Conducted Emissions Test Equipment

Equipment ID	Description	Manufacturer	Model Number	Last Cal.	Next Cal.
CBL076	Coax cable, RG223, N-male to BNC-male, 20-ft.	Pasternack	PE3476-240	2017-06-12	2018-06-12
LISN003	LISN, 50-ohm/50-uH, 2-conductor, 25A	Fischer Custom Com.	FCC-LISN-50-25-2-01-550V	2017-08-22	2018-08-22
PRE0101521 (75141)	EMI Test Receiver 9kHz-7GHz	Rohde & Schwarz	ESCI 7	2017-08-23	2018-08-23
TL001	Transient Limiter, 0.009-30MHz	Com-Power	LIT-930A	2017-06-12	2018-06-12
PS214	AC Power Source	Elgar	CW2501M (s/n 1523A02396)	NA	NA
PS215	AC Power Source	Elgar	CW2501M (s/n 1523A02397)	NA	NA
SOFTEMI	EMI Software	UL	Version 9.5	NA	NA
MM0168	Multi-meter	Agilent	U1232A	2017-09-25	2018-09-30
CDECABLE001	ANSI C63.4 1m extension cable.	UL	Per Annex B of ANSI C63.4	2017-07-03	2018-07-03

Figure 1 Test Setup for Conducted Emissions

Refer to UL Report R11694639-EP7

Figure 2 Conducted Emissions Graph – 15W Line 1

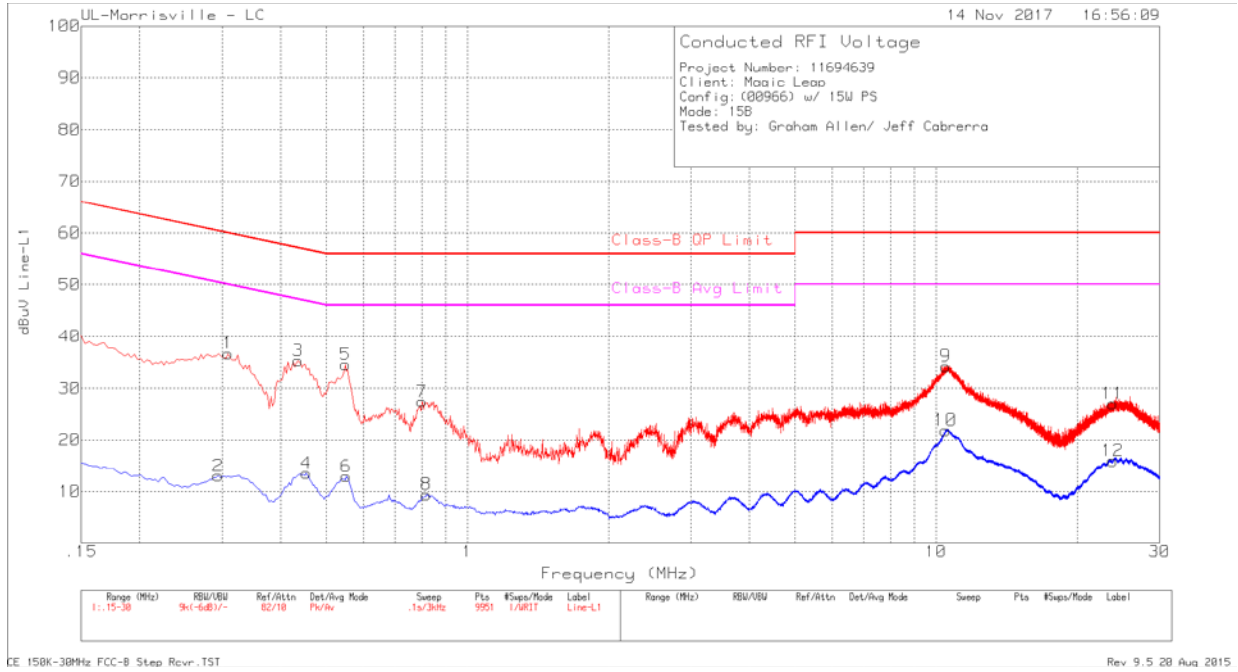

Table 3 Conducted Emissions Data Points – 15W Line 1

Range 1: Line-L1 .15 - 30MHz										
Marker	Frequency (MHz)	Meter Reading (dBuV)	Det	LISN VCF (dB)	Cbl/Limiter (dB)	Corrected Reading dBuV	Class-B QP Limit dBuV	Margin (dB)	Class-B Avg Limit dBuV	Margin (dB)
1	.309	26.71	Pk	.1	9.9	36.71	60	-23.29	-	-
2	.294	3.06	Av	.1	9.9	13.06	-	-	50.41	-37.35
3	.435	25.26	Pk	.1	9.9	35.26	57.16	-21.9	-	-
4	.453	3.62	Av	0	9.9	13.52	-	-	46.82	-33.3
5	.549	24.64	Pk	0	9.9	34.54	56	-21.46	-	-
6	.552	3	Av	0	9.9	12.9	-	-	46	-33.1
7	.801	17.56	Pk	0	9.9	27.46	56	-28.54	-	-
8	.819	-.48	Av	0	9.9	9.42	-	-	46	-36.58
9	10.503	24.03	Pk	.1	10.1	34.23	60	-25.77	-	-
10	10.476	11.62	Av	.1	10.1	21.82	-	-	50	-28.18
11	23.826	16.6	Pk	.2	10.2	27	60	-33	-	-
12	23.82	5.55	Av	.2	10.2	15.95	-	-	50	-34.05

Pk - Peak detector
 Av - Average detection

Figure 3 Conducted Emissions Graph – 15W Line 2

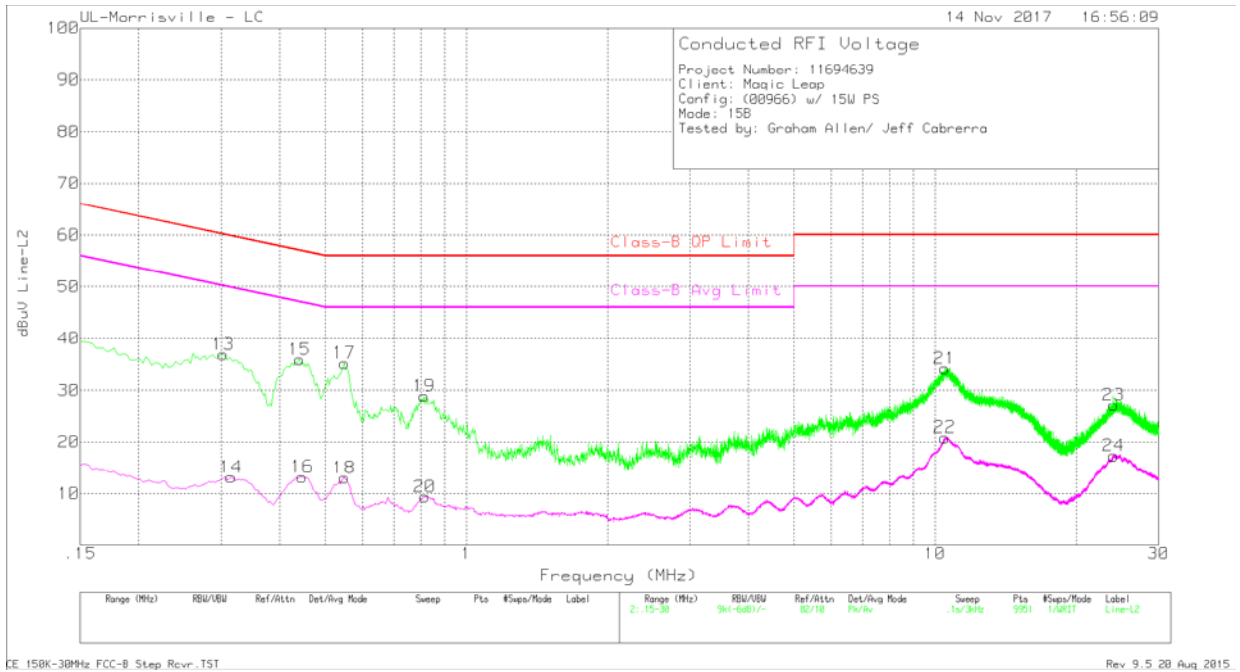

Table 4 Conducted Emissions Data Points – 15W Line 2

Range 2: Line-L2 .15 - 30MHz										
Marker	Frequency (MHz)	Meter Reading (dBuV)	Det	LISN VCF (dB)	Cbl/Limiter (dB)	Corrected Reading dBuV	Class-B QP Limit dBuV	Margin (dB)	Class-B Avg Limit dBuV	Margin (dB)
13	.303	26.9	Pk	.1	9.9	36.9	60.16	-23.26	-	-
14	.315	3.19	Av	.1	9.9	13.19	-	-	49.84	-36.65
15	.441	25.91	Pk	.1	9.9	35.91	57.04	-21.13	-	-
16	.447	3.23	Av	.1	9.9	13.23	-	-	46.93	-33.7
17	.549	25.33	Pk	0	9.9	35.23	56	-20.77	-	-
18	.549	3.16	Av	0	9.9	13.06	-	-	46	-32.94
19	.813	19.02	Pk	0	9.9	28.92	56	-27.08	-	-
20	.816	-.53	Av	0	9.9	9.37	-	-	46	-36.63
21	10.497	24.02	Pk	.1	10.1	34.22	60	-25.78	-	-
22	10.494	10.65	Av	.1	10.1	20.85	-	-	50	-29.15
23	24.051	16.73	Pk	.2	10.2	27.13	60	-32.87	-	-
24	24.039	6.91	Av	.2	10.2	17.31	-	-	50	-32.69

Pk - Peak detector
 Av - Average detection

Figure 4 Conducted Emissions Graph – 45W Line 1

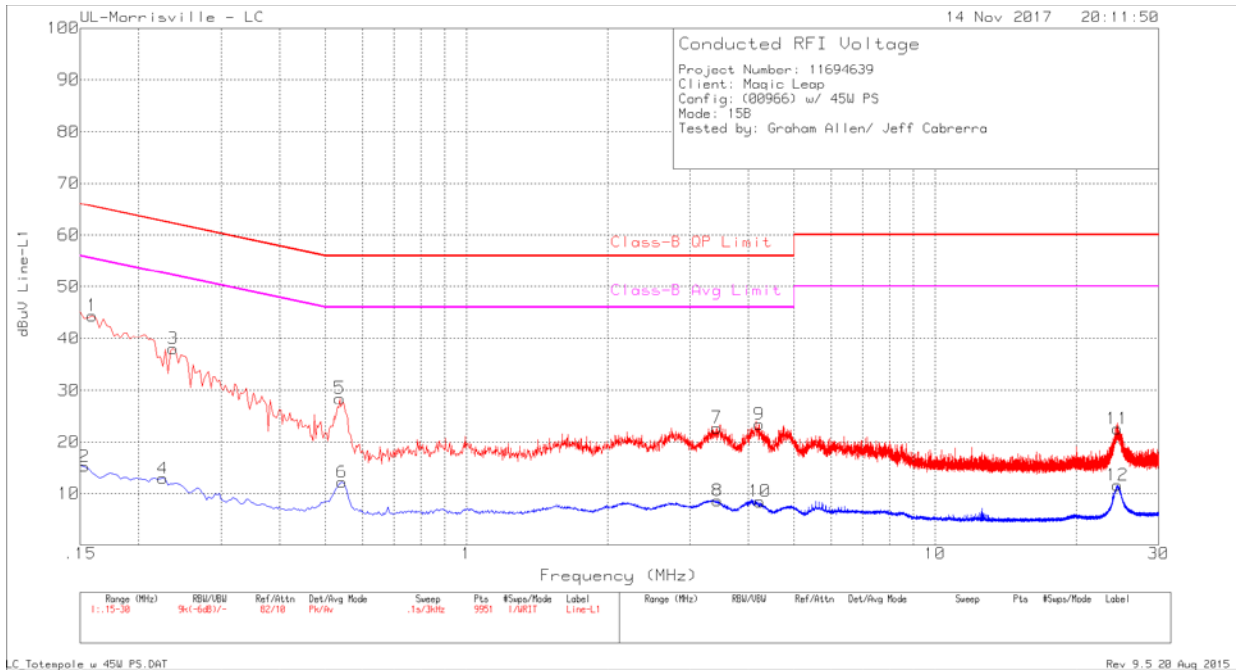

Table 5 Conducted Emissions Data Points – 45W Line 1

Range 1: Line-L1 .15 - 30MHz										
Marker	Frequency (MHz)	Meter Reading (dBuV)	Det	LISN VCF (dB)	Cbl/Limiter (dB)	Corrected Reading dBuV	Class-B QP Limit dBuV	Margin (dB)	Class-B Avg Limit dBuV	Margin (dB)
1	.159	34.23	Pk	.2	10	44.43	65.52	-21.09	-	-
2	.153	5.04	Av	.2	10	15.24	-	-	55.84	-40.6
3	.237	28.05	Pk	.1	9.9	38.05	62.2	-24.15	-	-
4	.225	2.92	Av	.1	9.9	12.92	-	-	52.63	-39.71
5	.537	18.56	Pk	0	9.9	28.46	56	-27.54	-	-
6	.543	2.27	Av	0	9.9	12.17	-	-	46	-33.83
7	3.42	12.68	Pk	0	10	22.68	56	-33.32	-	-
8	3.435	-1.38	Av	0	10	8.62	-	-	46	-37.38
9	4.221	13.36	Pk	0	10	23.36	56	-32.64	-	-
10	4.23	-1.55	Av	0	10	8.45	-	-	46	-37.55
11	24.519	12.11	Pk	.2	10.2	22.51	60	-37.49	-	-
12	24.495	1.22	Av	.2	10.2	11.62	-	-	50	-38.38

Pk - Peak detector
 Av - Average detection

Figure 5 Conducted Emissions Graph – 45W Line 2

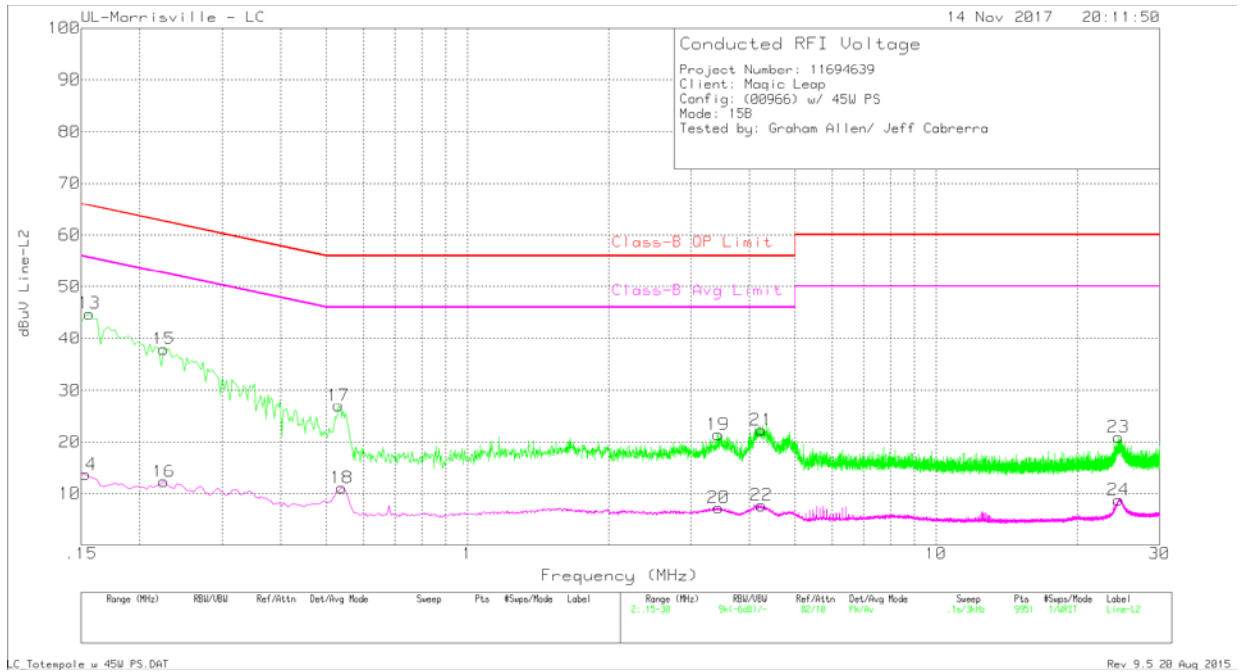

Table 6 Conducted Emissions Data Points – 45W Line 2

Range 2: Line-L2 .15 - 30MHz										
Marker	Frequency (MHz)	Meter Reading (dBuV)	Det	LISN VCF (dB)	Cbl/Limiter (dB)	Corrected Reading dBuV	Class-B QP Limit dBuV	Margin (dB)	Class-B Avg Limit dBuV	Margin (dB)
13	.156	34.62	Pk	.2	10	44.82	65.67	-20.85	-	-
14	.153	3.51	Av	.2	10	13.71	-	-	55.84	-42.13
15	.225	27.94	Pk	.1	9.9	37.94	62.63	-24.69	-	-
16	.225	2.34	Av	.1	9.9	12.34	-	-	52.63	-40.29
17	.531	17.12	Pk	0	9.9	27.02	56	-28.98	-	-
18	.54	1.19	Av	0	9.9	11.09	-	-	46	-34.91
19	3.429	11.4	Pk	0	10	21.4	56	-34.6	-	-
20	3.432	-2.72	Av	0	10	7.28	-	-	46	-38.72
21	4.236	12.25	Pk	0	10	22.25	56	-33.75	-	-
22	4.242	-2.28	Av	0	10	7.72	-	-	46	-38.28
23	24.519	10.51	Pk	.2	10.2	20.91	60	-39.09	-	-
24	24.519	-1.67	Av	.2	10.2	8.73	-	-	50	-41.27

Pk - Peak detector
 Av - Average detection

4.2 Test Conditions and Results – RADIATED EMISSIONS

Test Description	Measurements were made in a 3-meter semi-anechoic chamber that complies to CISPR 16/ANSI C63.4. Preliminary (peak) measurements were performed at an antenna to EUT separation distance of 3-meter. The EUT was rotated 360° about its azimuth with the receive antenna located at various heights in both horizontal and vertical polarities. Final measurements (quasi-peak or average as noted) were then performed by rotating the EUT 360° and adjusting the receive antenna height from 1 to 4-meters. All frequencies were investigated in both horizontal and vertical antenna polarity, where applicable.	
Basic Standard	FCC Part 15, Subparts A & B in conjunction with ANSI C63.4:2014	
UL LPG	80-EM-S0029	
	Frequency range	Measurement Point
Fully configured sample scanned over the following frequency range	30MHz – 1GHz	3 meter – Class B
	1-18 GHz	3 meter
Limits - Class B		
Frequency (MHz)	Limit (dBµV/m)	
	Quasi-Peak	Average
30-88	40	NA
88-216	43.5	NA
216-960	46	NA
960-1000	54	NA
1,000-18,000	NA	54
18,000-40,000	NA	54 ^{Note3}
Supplemental information: Note, the EUT was investigated in XYZ orientations and the Y-Axis was determined to be worst-case based on 30-1000MHz PK scan. Therefore all radiated testing done in the Y-Axis.		

Table 7 Radiated Emissions EUT Configuration Settings

Power Interface Mode #	EUT Configurations Mode #	EUT Operation Mode #
1	1	1

Table 8 Radiated Emissions Test Equipment

Equip. ID	Description	Manufacturer	Model Number	Last Cal.	Next Cal.
AT0073	Hybrid Broadband Antenna	Sunol Sciences Corp.	JB3	2017-07-18	2018-07-31
AT0072	Double-Ridged Waveguide Horn Antenna, 1 to 18 GHz	ETS Lindgren	3117	2017-04-05	2018-04-05
N-SAC02	Gain-loss string: 30-1000MHz	Various	Various	2017-06-11	2018-06-11
N-SAC03	Gain-loss string: 1-18GHz	Various	Various	2017-08-18	2018-08-18
SA0027	Spectrum Analyzer	Agilent	N9030A	2017-03-16	2018-03-16
SOFTEMI	EMI Software	UL	Version 9.5	NA	NA
s/n 161024690	Environmental Meter	Fisher Scientific	15-077-963	2016-12-21	2018-12-21

Figure 6 Test setup for Radiated Emissions

Refer to UL report R11694639-EP7.

Figure 7 Radiated Emissions Graph – 30-1000 MHz (15W Power Supply)

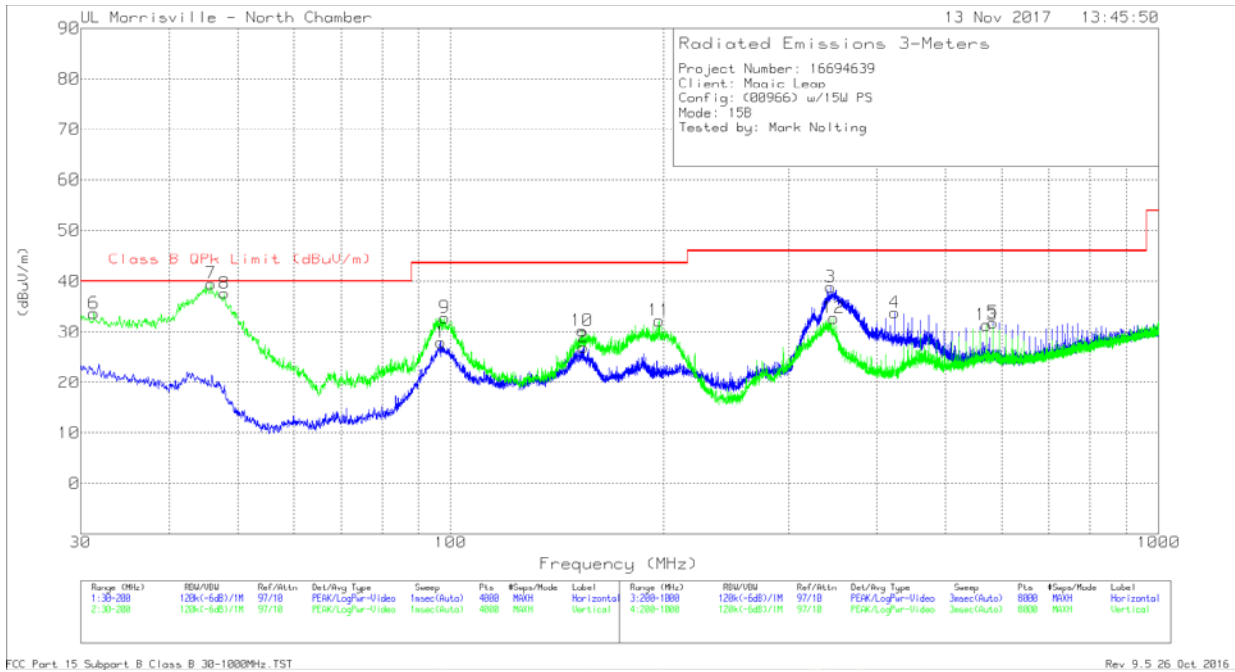

Table 9 Radiated Emissions Data Points - 30-1000 MHz (15W Power Supply)

Marker	Frequency (MHz)	Meter Reading (dBuV)	Det	AT0073 (dB/m)	Amp/Cbl (dB)	Corrected Reading (dBuV/m)	Class B QPk Limit (dBuV/m)	Margin (dB)	Azimuth (Degs)	Height (cm)	Polarity
1	96.7848	44.56	Pk	14.3	-31	27.86	43.52	-15.66	0-360	299	H
2	154.0471	39.76	Pk	17.6	-30.4	26.96	43.52	-16.56	0-360	199	H
3	344.0573	47.22	Qp	19.7	-29.2	37.72	46.02	-8.3	110	101	H
4	423.9291	40.98	Pk	21.6	-28.8	33.78	46.02	-12.24	0-360	102	H
5	583.6499	36.12	Pk	24	-28.3	31.82	46.02	-14.2	0-360	199	H
6	31.3178	39.41	Pk	25.9	-31.7	33.61	40	-6.39	0-360	101	V
7	45.8404	50.57	Qp	15.2	-31.5	34.27	40	-5.73	279	102	V
8	47.8971	49.3	Qp	14.2	-31.5	32	40	-8	287	101	V
9	98.0601	48.99	Pk	14.7	-30.9	32.79	43.52	-10.73	0-360	101	V
10	153.2819	42.97	Pk	17.7	-30.4	30.27	43.52	-13.25	0-360	101	V
11	197.0682	44.93	Pk	17.4	-30.1	32.23	43.52	-11.29	0-360	101	V
12	347.7192	42.01	Pk	19.9	-29.2	32.71	46.02	-13.31	0-360	102	V
13	571.3483	35.74	Pk	23.9	-28.3	31.34	46.02	-14.68	0-360	102	V

Pk - Peak detector

Qp - Quasi-Peak detector

Figure 8 Radiated Emissions Graph – 30-1000 MHz (45W Power Supply)

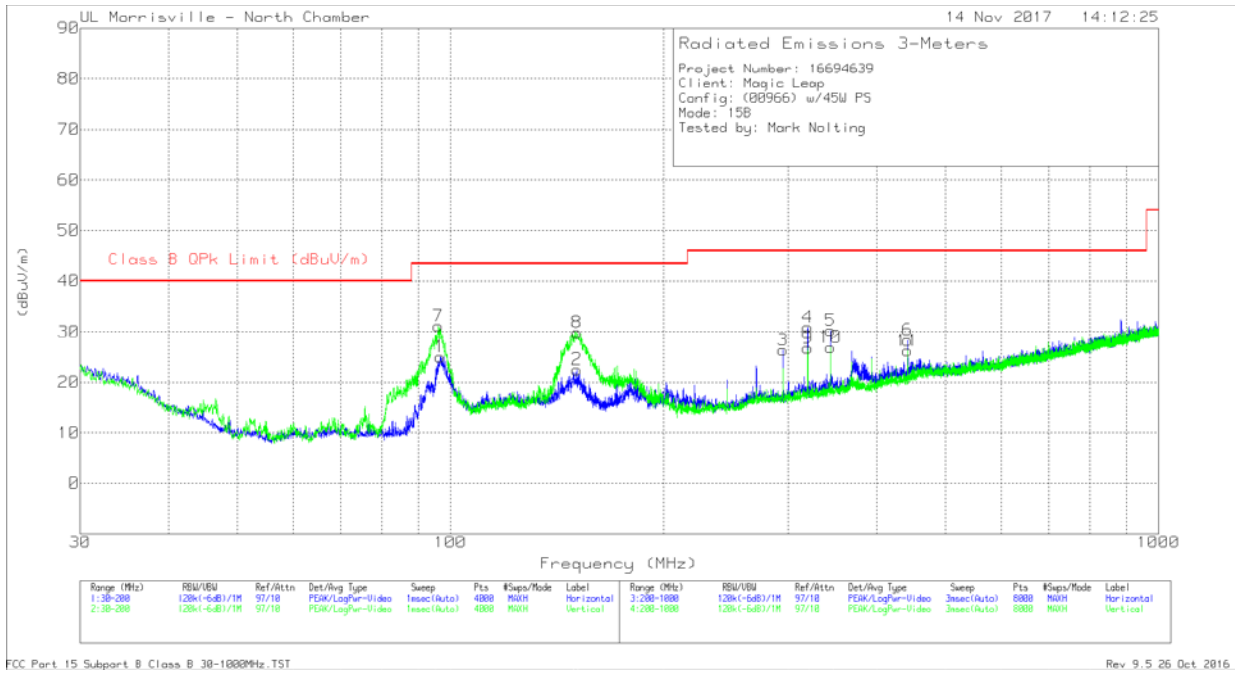

Table 10 Radiated Emissions Data Points - 30-1000 MHz (45W Power Supply)

Marker	Frequency (MHz)	Meter Reading (dBuV)	Det	AT0073 (dB/m)	Amp/Cbl (dB)	Corrected Reading (dBuV/m)	Class B QPk Limit (dBuV/m)	Margin (dB)	Azimuth (Degs)	Height (cm)	Polarity
1	96.7635	41.73	Pk	14.3	-31	25.03	43.52	-18.49	0-360	299	H
2	150.7738	35.31	Pk	17.7	-30.5	22.51	43.52	-21.01	0-360	199	H
3	294.9123	37.07	Pk	18.8	-29.5	26.37	46.02	-19.65	0-360	102	H
4	319.5155	40.77	Pk	19.5	-29.4	30.87	46.02	-15.15	0-360	102	H
5	344.0187	39.77	Pk	19.7	-29.2	30.27	46.02	-15.75	0-360	102	H
6	442.3315	35.32	Pk	21.7	-28.7	28.32	46.02	-17.7	0-360	199	H
7	96.1471	48.01	Pk	14.1	-31	31.11	43.52	-12.41	0-360	101	V
8	150.9013	42.63	Pk	17.7	-30.5	29.83	43.52	-13.69	0-360	101	V
9	319.5155	36.68	Pk	19.5	-29.4	26.78	46.02	-19.24	0-360	102	V
10	344.0187	36.42	Pk	19.7	-29.2	26.92	46.02	-19.1	0-360	102	V
11	442.3315	33.25	Pk	21.7	-28.7	26.25	46.02	-19.77	0-360	102	V

Pk - Peak detector

Figure 9 Radiated Emissions Graph – 1-13 GHz (15W Power Supply)

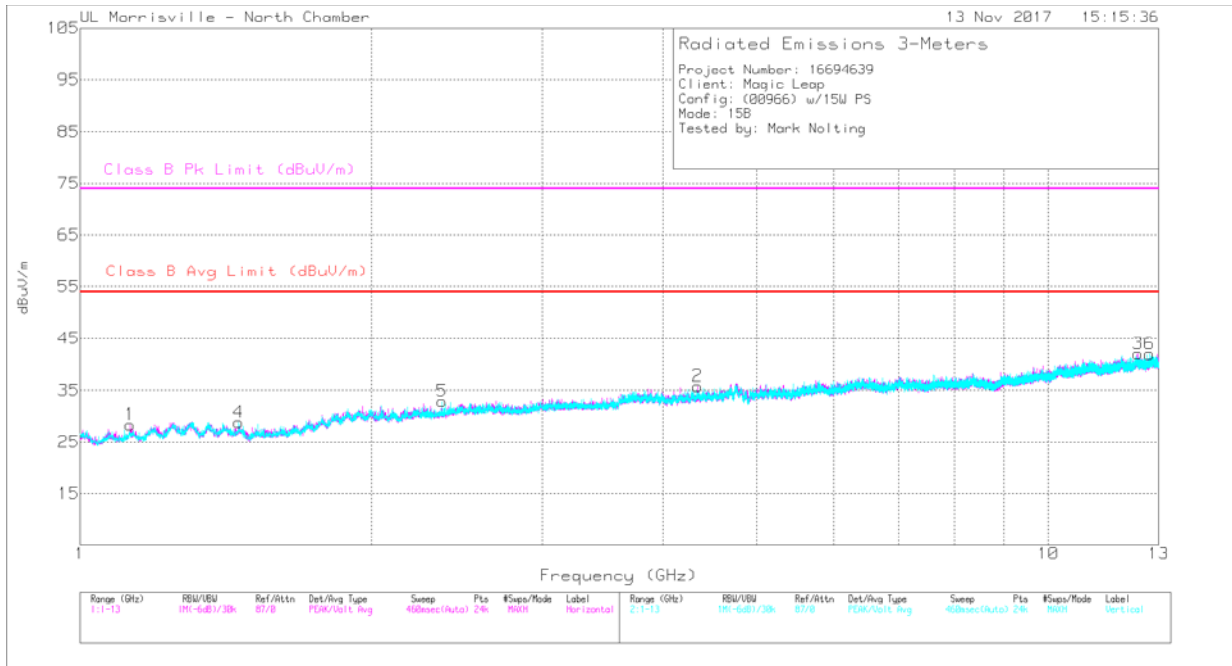

Table 11 Radiated Emissions Data Points – 1-13 GHz (15W Power Supply)

Marker	Freq. (GHz)	Meter Reading (dBuV)	Det	AT0072 AF (dB/m)	Amp/Cbl/Filtr/Pad (dB)	Corrected Reading dBuV/m	Class B Avg Limit (dBuV/m)	Margin (dB)	Class B Pk Limit (dBuV/m)	Margin (dB)	Azimuth (Degs)	Height (cm)	Polarity
1	1.127	45.03	Pk	27.7	-36.6	36.13	-	-	74	-37.87	199	234	H
	1.127	31.15	Av	27.7	-36.6	22.25	54	-31.75	-	-	199	234	H
2	4.342	40.67	Pk	33.6	-32.2	42.07	-	-	74	-31.93	4	132	H
	4.342	28.54	Av	33.6	-32.2	29.94	54	-24.06	-	-	4	132	H
3	12.378	35.52	Pk	38.9	-26.3	48.12	-	-	74	-25.88	178	170	H
	12.378	22.83	Av	38.9	-26.3	35.43	54	-18.57	-	-	178	170	H
4	1.459	42.26	Pk	28.4	-35.7	34.96	-	-	74	-39.04	30	121	V
	1.459	29.94	Av	28.4	-35.7	22.64	54	-31.36	-	-	30	121	V
5	2.365	41.14	Pk	31.7	-34	38.84	-	-	74	-35.16	51	295	V
	2.365	28.48	Av	31.7	-34	26.18	54	-27.82	-	-	51	295	V
6	12.72	36.49	Pk	39.1	-27.4	48.19	-	-	74	-25.81	322	375	V
	12.72	23.48	Av	39.1	-27.4	35.18	54	-18.82	-	-	322	375	V

Pk - Peak detector
 Av - Average detection

Figure 10 Radiated Emissions Graph – 1-13 GHz (45W Power Supply)

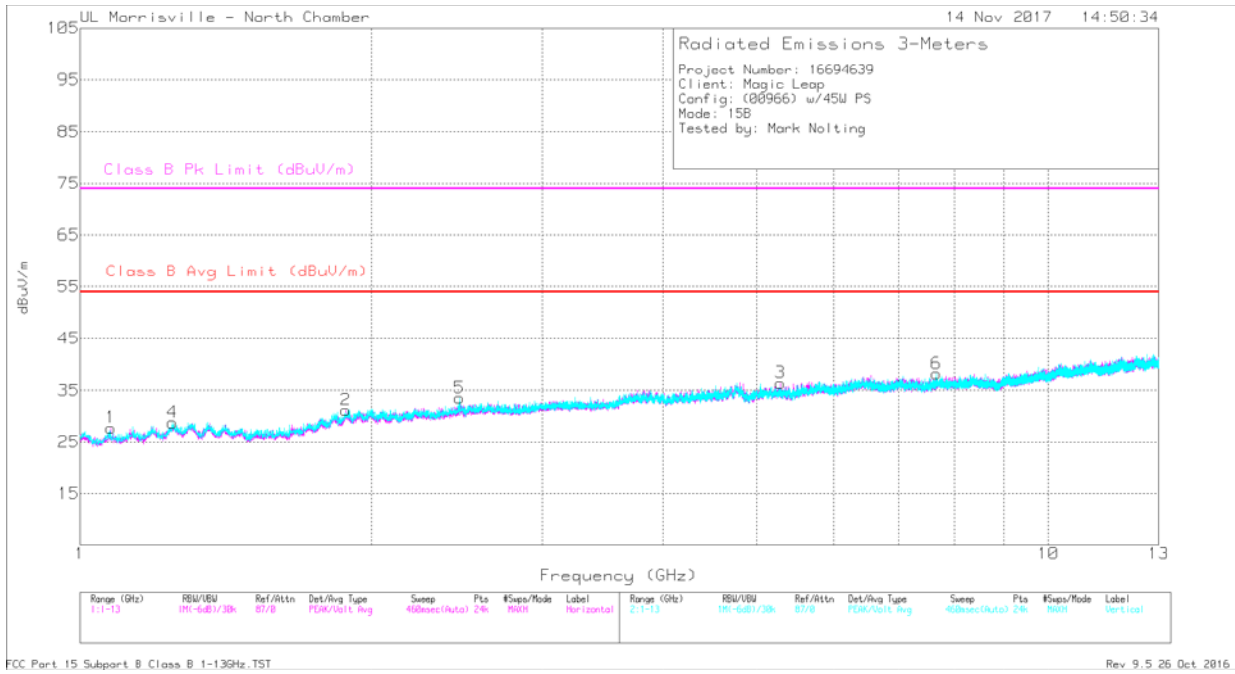

Table 12 Radiated Emissions Data Points – 1-13 GHz (45W Power Supply)

Marker	Freq. (GHz)	Meter Reading (dBuV)	Det	AT0072 AF (dB/m)	Amp/Cbl/Filtr/Pad (dB)	Corrected Reading dBuV/m	Class B Avg Limit (dBuV/m)	Margin (dB)	Class B Pk Limit (dBuV/m)	Margin (dB)	Azimuth (Degs)	Height (cm)	Polarity
1	1.076	44.08	Pk	27.2	-36.7	34.58	-	-	74	-39.42	173	297	H
	1.075	31.36	Av	27.2	-36.7	21.86	54	-32.14	-	-	173	297	H
2	1.88	43	Pk	31.2	-35	39.2	-	-	74	-34.8	126	248	H
	1.881	29.89	Av	31.2	-35	26.09	54	-27.91	-	-	126	248	H
3	5.285	40.39	Pk	34.4	-31.8	42.99	-	-	74	-31.01	178	103	H
	5.285	27.42	Av	34.4	-31.8	30.02	54	-23.98	-	-	178	103	H
4	1.246	42.7	Pk	28.9	-36.2	35.4	-	-	74	-38.6	8	180	V
	1.246	30.16	Av	28.9	-36.2	22.86	54	-31.14	-	-	8	180	V
5	2.463	41.53	Pk	32.3	-34	39.83	-	-	74	-34.17	234	246	V
	2.464	30.4	Av	32.3	-34	28.7	54	-25.3	-	-	234	246	V
6	7.661	37.87	Pk	35.7	-29.1	44.47	-	-	74	-29.53	356	136	V
	7.661	25.07	Av	35.7	-29.1	31.67	54	-22.33	-	-	356	136	V

Pk - Peak detector
 Av - Average detection

Appendix A

Accreditations and Authorizations



NVLAP Lab code: 200246-0

NVLAP: The National Institute of Standards and Technology (NIST) administers the National Voluntary Laboratory Accreditation Program (NVLAP). NVLAP is comprised of laboratory accreditation programs (LAPs) which are established on the basis of requests and demonstrated need. Each LAP includes specific calibration and/or test standards and related methods and protocols assembled to satisfy the unique needs for accreditation in a field of testing or calibration. NVLAP accredits public and private laboratories based on evaluation of their technical qualifications and competence to carry out specific calibrations or tests. Accreditation criteria are established in accordance with the U.S. Code of Federal Regulations (CFR, Title 15, Part 285), NVLAP Procedures and General Requirements, and encompass the requirements of ISO/IEC 17025. For a full scope listing see <http://www.nist.gov/nvlap/>



FCC: Details of the measurement facilities used for these tests have been filed with the Federal Communications Commission's Laboratory in Columbia, Maryland (Ref. No. 91039).



Industry Canada Industrie Canada

Industry of Canada: Accredited by Industry Canada for performance of radiated measurements. Our test site complies with RSP-100, Issue 7, Section 3.3. File #: IC 2180C



VCCI: Accepted as an Associate Member to the VCCI. The measurement facilities detailed in this test report have been registered in accordance with Regulations for Voluntary Control Measures, Article 8. Registration Nos.:

- Test Station 5 (Location A): G-246
- All Other Test Stations: A-0046



ICASA: ICASA (Independent Communications Authority of South Africa) has appointed UL as a Designated Test Laboratory to test Telecommunications equipment for type approval in compliance with CISPR 22 to assist in fulfilling its mandate under section 54(1) of the Telecommunications Act, 1996 (Act 103 of 1996).



NIST/CAB: Validated by the European Commission as a U.S. Conformity Assessment Body (CAB) of the U.S.-EU Mutual Recognition Agreement (MRA) for the Electromagnetic Compatibility - Council Directive 2004/108/EC, Annex III. Also validated for the Telecommunication Equipment-Council Directive 99/5/EC, Annex III and IV, Identification Number: 0983.

NIST/CAB: Provisioned to act as a U.S. Conformity Assessment Body (CAB) under Appendix B, Phase I Procedures, of the Asia Pacific Economic Cooperation (APEC) MRA between the American Institute in Taiwan (AIT) and the United States. Our laboratory is considered qualified to test equipment subject to the applicable EMC regulations of the Chinese Taipei Bureau of Standards, Metrology and Inspection (BSMI) which require testing to CNS 13438 (CISPR 22).

NIST/CAB: Recognized by the Infocomm Development Authority of Singapore (IDA) under the Asia Pacific Economic Cooperation Mutual Recognition Agreement (APEC MRA). Our laboratory is provisionally designated to act as a Conformity Assessment Body (CAB) under Appendix B, Phase I Procedures, of the APEC MRA. Our scope of designation includes IDA TS EMC (CISPR 22).