



FCC/IC RADIO TEST REPORT

Applicant : AQUAMUTANT TECHNOLOGY CO., LTD.
Address : 11F.-1, NO.65, SONGDE RD., XINYI DIST., TAIPEI CITY
: 110, TAIWAN
Equipment : WiFi IEEE802.11 b/g/n module
Model No. : AQM100-WM
Trade Name : **AquaMutant**
FCC ID : 2AM3NAQM100WM01
IC : 23049-AQM100WM

I HEREBY CERTIFY THAT :

The sample was received on May 17, 2017 and the testing was carried out on Jul. 27, 2017 at CerpPASS Technology Corp. The test result refers exclusively to the test presented test model / sample. Without written approval of CerpPASS Technology Corp., the test report shall not be reproduced except in full.

Approved by:

Mark Liao

Assistant Manager

Laboratory Accreditation:

- CerpPASS Technology Corporation Test Laboratory
- | | |
|----------------------|-------------|
| TAF LAB Code: | 1439 |
|----------------------|-------------|
- CerpPASS Technology(SuZhou) Co., Ltd.
- | | |
|------------------------|-----------------|
| NVLAP LAB Code: | 200814-0 |
| CNAS LAB Code: | L5515 |



CONTENTS

1. Summary of Test Procedure and Test Results	5
1.1 Applicable Standards.....	5
2. Test Configuration of Equipment under Test	6
2.1 Feature of Equipment under Test.....	6
2.2 Carrier Frequency of Channels.....	6
2.3 Test Mode and Test Software.....	6
2.4 Description of Test System.....	7
2.5 General Information of Test.....	8
2.6 Measurement Uncertainty.....	8
2.7 Duty cycle.....	9
3. Test Equipment and Ancillaries Used for Tests	10
4. Antenna Requirements	11
4.1 Standard Applicable.....	11
4.2 Antenna Construction and Directional Gain.....	11
5. Test of AC Power Line Conducted Emission	12
5.1 Test Limit.....	12
5.2 Test Procedures.....	12
5.3 Typical Test Setup.....	12
5.4 Test Result and Data.....	13
6. Test of Spurious Emission (Radiated)	15
6.1 Test Limit.....	15
6.2 Test Procedures.....	15
6.3 Typical Test Setup.....	16
6.4 Test Result and Data (9KHz ~ 30MHz).....	17
6.5 Test Result and Data (30MHz ~ 1GHz).....	17
6.6 Test Result and Data (1GHz ~ 25GHz).....	18
6.7 Restricted Bands of Operation.....	27
6.8 Restrict Band Emission Measurement Data.....	28
7. Test of Spurious Emission (Conducted)	30
7.1 Test Limit.....	30
7.2 Test Procedure.....	30
7.3 Test Setup Layout.....	30
7.4 Test Result and Data.....	31
8. 6dB Bandwidth & 99% Bandwidth	35
8.1 Test Limit.....	35
8.2 Test Procedures.....	35
8.3 Test Setup Layout.....	35
8.4 Test Result and Data.....	36
9. Maximum Peak Output Power	42
9.1 Test Limit.....	42
9.2 Test Procedures.....	42
9.3 Test Setup Layout.....	42
9.4 Test Result and Data.....	43
10.Power Spectral Density	44



10.1 Test Limit	44
10.2 Test Procedures	44
10.3 Test Setup Layout.....	44
10.4 Test Result and Data.....	45



History of this test report

ORIGINAL

Additional attachment as following record:

Attachment No.	Issue Date	Description
DEF11704140	Jul. 28, 2017	Original



1. Summary of Test Procedure and Test Results

1.1 Applicable Standards

ANSI C63.10: 2013

KDB 558074 D01 DTS Meas Guidance v03r05

FCC Rules and Regulations Part 15 Subpart C §15.247

RSS-247 Issue 2

RSS-Gen

Performed Test Item	Normative References		Test Performed	Result
	FCC	IC		
Conducted Emission	FCC CFR Title 47 Part 15 Subpart C: 2014 Section 15.207	RSS-GEN 8.8	Yes	Pass
Radiated Emission	FCC CFR Title 47 Part 15 Subpart C: 2014 Section 15.209	RSS-GEN Section 6.4 & 6.5	Yes	Pass
RF Antenna Conducted Spurious	FCC CFR Title 47 Part 15 Subpart C: 2014 Section 15.247(d)	RSS-247 5.5	Yes	Pass
Radiated Emission Band Edge	FCC CFR Title 47 Part 15 Subpart C: 2014 15.247(d)	RSS-247 5.5	Yes	Pass
6dB Bandwidth & 99% Bandwidth	FCC CFR Title 47 Part 15 Subpart C: 2014 Section 15.247(a)(2)	RSS-247 5.2 (a)	Yes	Pass
Output Power	FCC CFR Title 47 Part 15 Subpart C: 2014 Section 15.247(b)(3)	RSS-247 5.4 (d)	Yes	Pass
Power Spectral Density	FCC CFR Title 47 Part 15 Subpart C: 2014 Section 15.247(e)	RSS-247 5.2 (b)	Yes	Pass



2. Test Configuration of Equipment under Test

2.1 Feature of Equipment under Test

Equipment	WiFi IEEE802.11 b/g/n module
Model No.	AQM100-WM
Frequency Range	802.11b/g/n(20MHz): 2412-2462MHz
Modulation Type	802.11b:DSSS(CCK,QPSK, BPSK) 802.11g/n: OFDM (BPSK / QPSK / 16QAM / 64QAM)
Data Rate	802.11b: 11Mbps(CCK) with fall back rates of 5.5/2/1Mbps 802.11g: 54Mbps with fall back rates of 48/36/24/18/12/11 /6Mbps 802.11n: up to 150Mbps
Number of Channels	IEEE 802.11b/g/n (20MHz):11
Antenna Type	PCB Antenna 2dBi

2.2 Carrier Frequency of Channels

802.11b, 802.11g, 802.11n HT 20 (2412MHz~2462MHz)

Channel	Frequency(MHz)	Channel	Frequency(MHz)
*01	2412	07	2442
02	2417	08	2447
03	2422	09	2452
04	2427	10	2457
05	2432	*11	2462
*06	2437	---	---

Note: Channels remarked * are selected to perform test.

2.3 Test Mode and Test Software

- During testing, the interface cables and equipment positions were varied according to ANSI C63.4.
- The complete test system included EUT for the RF test.
- An executive program, "**UartAssist.exe**" which transmits and receives data through Wireless.
- The EUT had been tested under operating condition
After verification, all tests were carried out with the worst case test modes as shown below except radiated spurious emission below 1GHz and power line conducted emissions below 30MHz, which worst case was in normal link mode only.
EUT staying in continuous transmitting mode was programmed.
- Test modes:
Mode 1: IEEE 802.11b
Mode 2: IEEE 802.11g
Mode 3: IEEE 802.11n 20



2.4 Description of Test System

Device	Manufacturer	Model No.	Description
USB Mouse	DELL	OXN967	R41108
Notebook	SONY	PCG-71811P	R33021

Cable:

No.	Cable	Quantity	Description
A	USB Cable	1	1.2m Shielding
B	USB Mouse Cable	1	1.8m Non Shielding

**2.5 General Information of Test**

☒	Test Site	CerpPASS Technology Corporation Test Laboratory Address: No.10, Ln. 2, Lianfu St., Luzhu Dist., Taoyuan City 33848, Taiwan (R.O.C.) Tel:+886-3-3226-888 Fax:+886-3-3226-881 Address: No.68-1, Shihbachongsi, Shihding Township, New Taipei City 223, Taiwan, R.O.C. Tel: +886-2-2663-8582
	FCC	TW1079, TW1061,390316, 228391, 641184
	IC	4934B-1, 4934E-1, 4934E-2
	VCCI	T-2205 for Telecommunication Test C-4663 for Conducted emission test R-3428, R-4218 for Radiated emission test G-812, G-813 for radiated disturbance above 1GHz
Frequency Range Investigated:		Conducted: from 150kHz to 30 MHz Radiation: from 30 MHz to 25000MHz
Test Distance:		The test distance of radiated emission from antenna to EUT is 3 M.

2.6 Measurement Uncertainty

Measurement Item	Measurement Frequency	Polarization	Uncertainty
Conducted Emission	9 kHz ~ 30 MHz	LINE/NEUTRAL	±2.71 dB
Radiated Emission	30 MHz ~ 25GHz	Vertical	±4.11 dB
		Horizontal	±4.10 dB
Occupied Bandwidth	---	---	±7500 Hz
Maximum Peak Output Power	---	---	±1.4 dB
Power Spectral Density	---	---	±2.2 dB



2.7 Duty cycle

Test Item	Duty cycle
Test Date	2017-07-22

Mode	Frequency (MHz)	Measurement (%)
802.11b	2412	88.98
802.11g	2412	57.02
802.11n(20MHz)	2412	55.93

Transmit at channel 1 by 802.11b

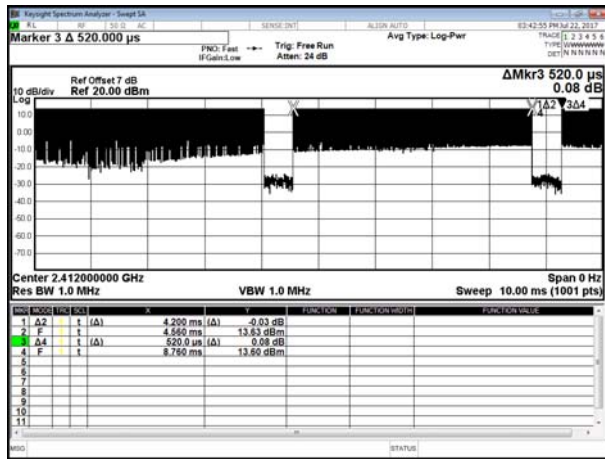

Transmit at channel 1 by 802.11g

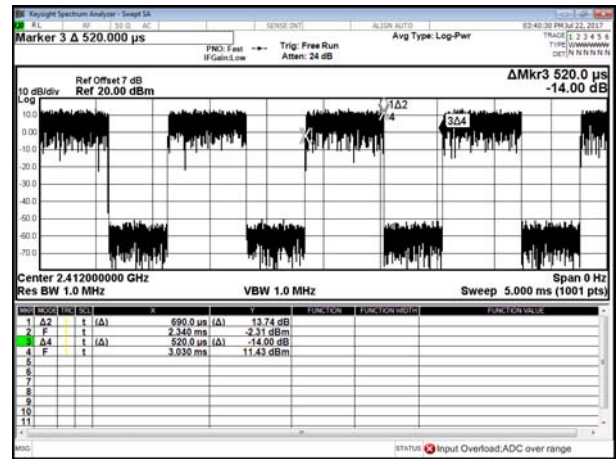

Transmit at channel 1 by 802.11n(20MHz)

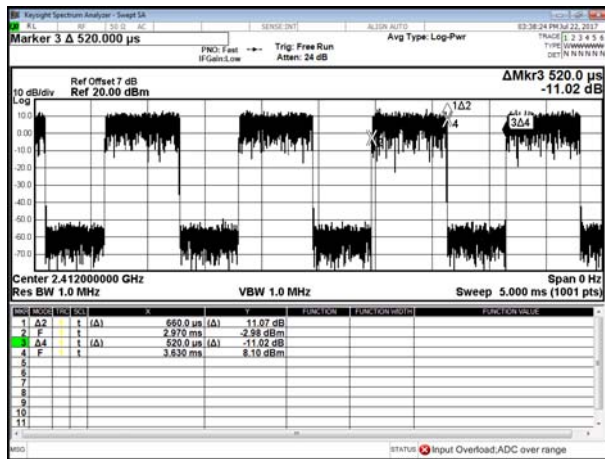



3. Test Equipment and Ancillaries Used for Tests

Instrument	Manufacturer	Model No.	Serial No.	Calibration Date	Valid Date
Test Receiver	R&S	ESCI	100564	2017.02.14	2018.02.13
LISN	SCHWARZBECK	NSLK 8127	8127748	2017.02.14	2018.02.13
LISN	SCHWARZBECK	NSLK 8127	8127749	2017.02.14	2018.02.13
Pulse Limiter with 10dB Attenuation	SCHWARZBECK	VTSD 9561-F	9561-F106	2017.02.14	2018.02.13
Temperature/Humidity Meter	mingle	ETH529	N/A	2017.02.14	2018.02.13
AMPLIFIER	HP	8447F	3113A05915	2017.02.14	2018.02.13
Loop Antenna	R&S	HFH2-Z2	100150	2016.10.24	2017.10.23
BILOG Antenna	SCHAFFNER	CBL6112D	22241	2017.02.14	2018.02.13
Horn Antenna	Sunol	DRH-118	A072913	2016.10.12	2017.10.11
Broad-Band Horn Antenna	Schwarzbeck	BBHA9170	9170-347	2017.05.26	2018.05.25
Preamplifier	COM-POWER	PA-840	711885	2017.02.14	2018.02.13
Temp&Humidity& barometer	mingle	ETH529	N/A	2017.02.14	2018.02.13
Preamplifier	Field	AFS44-00101800-25-10P-44	1579008	2016.09.30	2017.09.29
ESG VECTOR SIGNAL GENERATOR	Agilent	E4438C	MY45092582	2017.05.26	2018.05.25
MXG VECTOR SIGNAL GENERATOR	Agilent	N5182B	MY53050127	2017.05.26	2018.05.25
EXA Signal Analyzer	Agilent	N9020A	US46220290	2017.05.26	2018.05.25
Power sensor	e-channel	ERS-180T-24	TW5451026	2017.05.26	2018.05.25
Series Power Meter	ANRITSU	ML24958A	1224005	2017.02.14	2018.02.13



4. Antenna Requirements

4.1 Standard Applicable

For intentional device, according to FCC 47 CFR Section 15.203, an intentional radiator shall be designed to ensure that no antenna other than that furnished by the responsible party shall be used with the device.

And according to FCC 47 CFR Section 15.247 (b), if transmitting antennas of directional gain greater than 6dBi are used, the power shall be reduced by the amount in dB that the directional gain of the antenna exceeds 6dBi.

4.2 Antenna Construction and Directional Gain

No.	Antenna Type	Antenna Gain
1	PCB Antenna	2dBi



5. Test of AC Power Line Conducted Emission

5.1 Test Limit

Conducted Emissions were measured from 150 kHz to 30 MHz with a bandwidth of 9 KHz on the 120 VAC power and return leads of the EUT according to the methods defined in ANSI C63.10-2013. The EUT was placed on a nonmetallic stand in a shielded room 0.8 meters above the ground plane as shown in section 6.2.2. The interface cables and equipment positioning were varied within limits of reasonable applications to determine the position produced maximum conducted emissions.

Frequency (MHz)	Quasi Peak (dB μ V)	Average (dB μ V)
0.15 – 0.5	66-56*	56-46*
0.5 – 5.0	56	46
5.0 – 30.0	60	50

*Decreases with the logarithm of the frequency.

5.2 Test Procedures

The EUT was setup according to ANSI C63.10, 2013 and tested according to DTS test procedure of Oct 2014 KDB558074 for compliance to FCC 47CFR 15.247 requirements. The EUT was placed on a platform of nominal size, 1 m by 1.5 m, raised 80 cm above the conducting ground plane. The vertical conducting plane was located 40 cm to the rear of the EUT. All other surfaces of EUT were at least 80 cm from any other grounded conducting surface. The EUT and simulators are connected to the main power through a line impedance stabilization network (LISN). The LISN provides a 50 ohm /50uH coupling impedance for the measuring equipment. The peripheral devices are also connected to the main power through a LISN. (Please refer to the block diagram of the test setup and photographs) Each current-carrying conductor of the EUT power cord, except the ground (safety) conductor, was individually connected through a LISN to the input power source. The excess length of the power cord between the EUT and the LISN receptacle were folded back and forth at the center of the lead to form a bundle not exceeding 40 cm in length. Conducted emissions were investigated over the frequency range from 0.15MHz to 30MHz using a receiver bandwidth of 9kHz.

5.3 Typical Test Setup

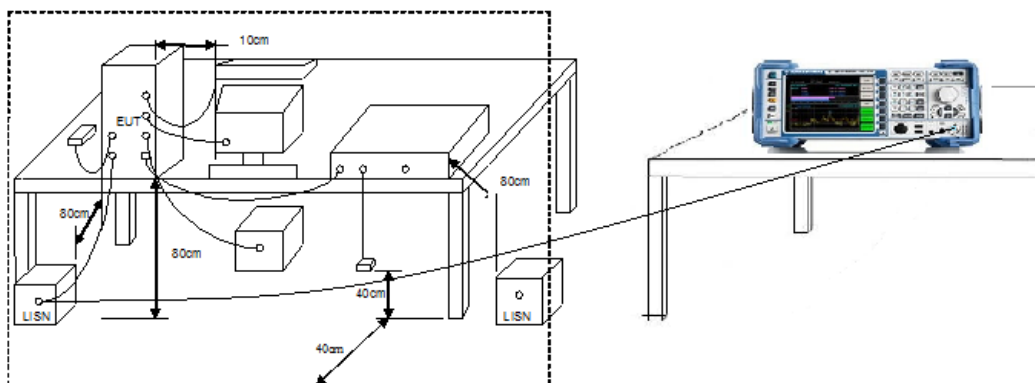



5.4 Test Result and Data

Test Mode :	Normal Link	Phase :	Line
Temperature :	20°C	Humidity:	51%
Pressur(mbar) :	1002	Date:	Jun. 03, 2017

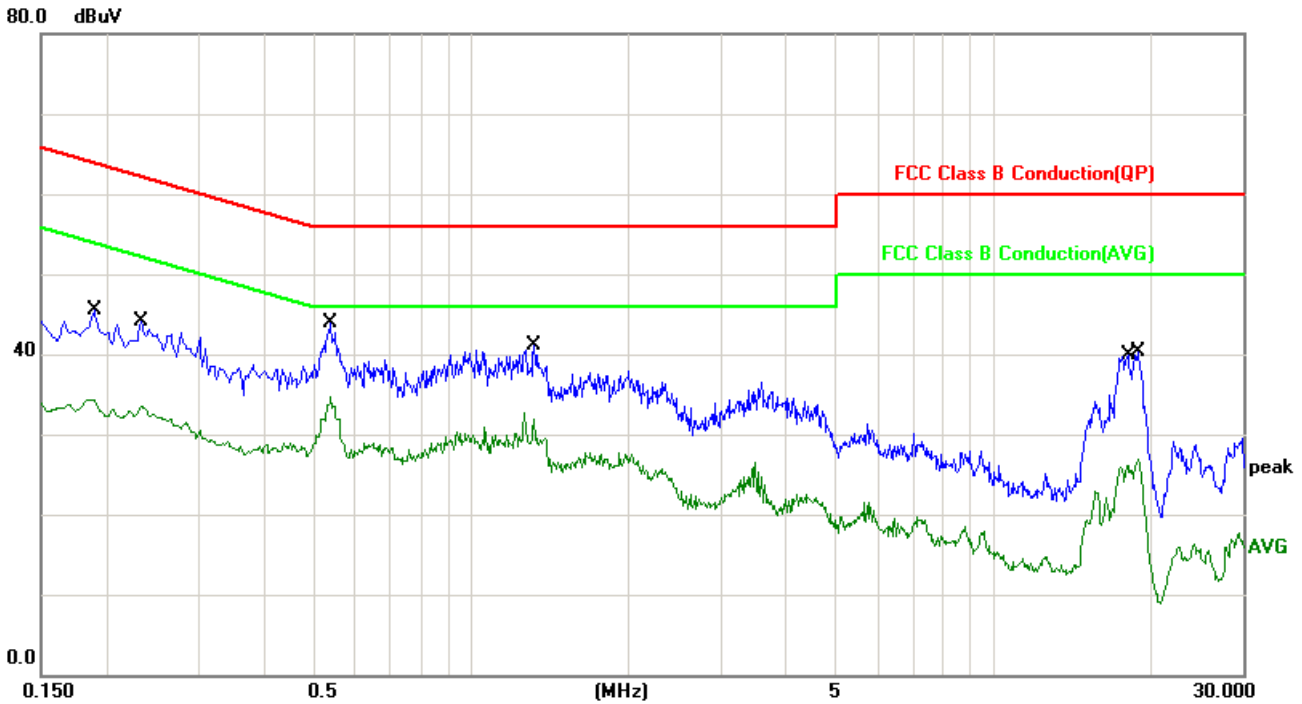

No.	Frequency (MHz)	Factor (dB)	Reading (dBuV)	Level (dBuV)	Limit (dBuV)	Margin (dB)	Detector
1	0.1900	10.06	29.68	39.74	64.03	-24.29	QP
2	0.1900	10.06	23.60	33.66	54.03	-20.37	AVG
3	0.2340	10.04	28.52	38.56	62.30	-23.74	QP
4	0.2340	10.04	22.80	32.84	52.30	-19.46	AVG
5	0.5380	9.92	29.58	39.50	56.00	-16.50	QP
6	0.5380	9.92	24.42	34.34	46.00	-11.66	AVG
7	1.3180	10.43	26.08	36.51	56.00	-19.49	QP
8	1.3180	10.43	20.64	31.07	46.00	-14.93	AVG
9	18.1140	10.48	20.76	31.24	60.00	-28.76	QP
10	18.1140	10.48	12.62	23.10	50.00	-26.90	AVG
11	18.8940	10.52	22.15	32.67	60.00	-27.33	QP
12	18.8940	10.52	14.75	25.27	50.00	-24.73	AVG

Note: Measurement Level = Reading Level + Correct Factor+ Attenuator



Test Mode :	Normal Link	Phase :	Neutral
Temperature :	20°C	Humidity :	51%
Pressur(mbar) :	1002	Date :	Jun. 03, 2017

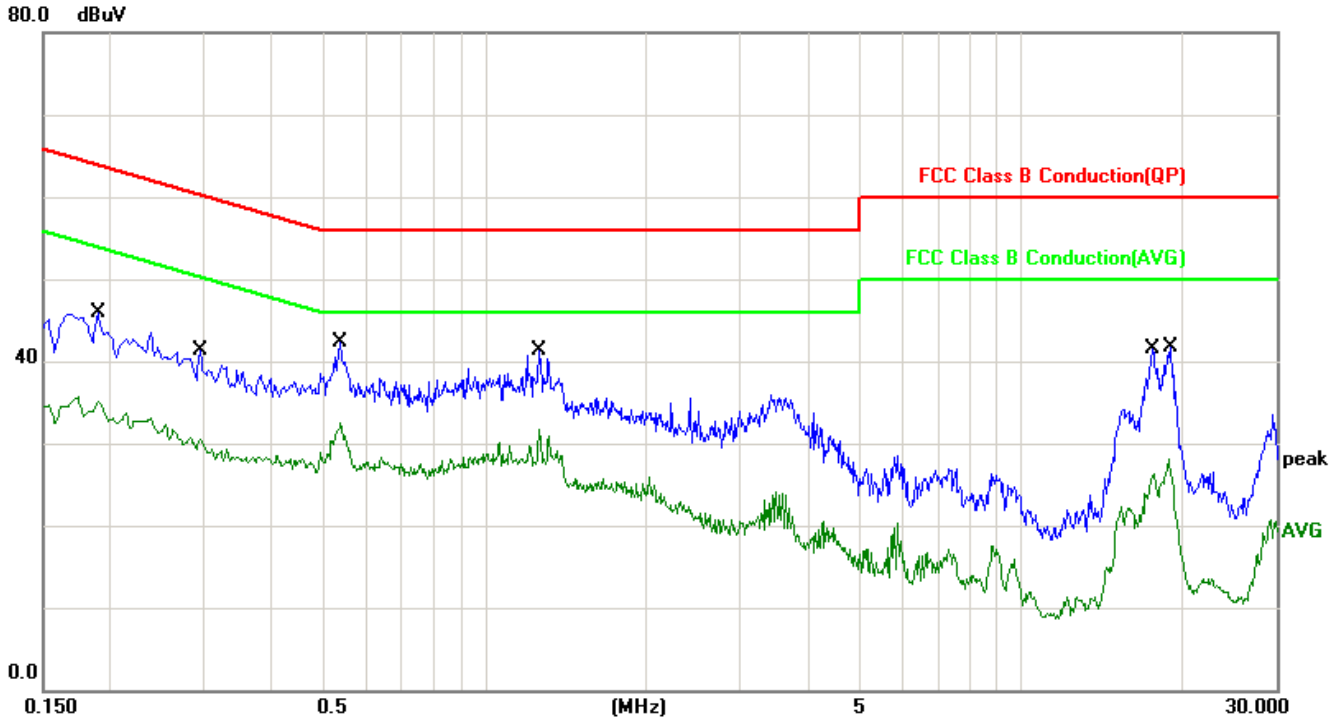

No.	Frequency (MHz)	Factor (dB)	Reading (dBuV)	Level (dBuV)	Limit (dBuV)	Margin (dB)	Detector
1	0.1900	10.06	31.78	41.84	64.03	-22.19	QP
2	0.1900	10.06	24.33	34.39	54.03	-19.64	AVG
3	0.2940	10.01	25.36	35.37	60.41	-25.04	QP
4	0.2940	10.01	19.78	29.79	50.41	-20.62	AVG
5	0.5380	9.92	27.32	37.24	56.00	-18.76	QP
6	0.5380	9.92	21.93	31.85	46.00	-14.15	AVG
7	1.2660	10.14	26.97	37.11	56.00	-18.89	QP
8	1.2660	10.14	21.58	31.72	46.00	-14.28	AVG
9	17.6180	10.46	22.83	33.29	60.00	-26.71	QP
10	17.6180	10.46	13.73	24.19	50.00	-25.81	AVG
11	19.0780	10.53	22.28	32.81	60.00	-27.19	QP
12	19.0780	10.53	14.72	25.25	50.00	-24.75	AVG

Note: Measurement Level = Reading Level + Correct Factor+ Attenuator



6. Test of Spurious Emission (Radiated)

6.1 Test Limit

FCC §15.247(d), RSS-247 5.5

In any 100kHz bandwidth outside the frequency band in which the spread spectrum or digitally modulated intentional radiator is operating, the radio frequency power that is produced by the intentional radiator shall be at least 20dB below that in the 100kHz bandwidth within the band that contains the highest level of the desired power, based on either an RF conducted or a radiated measurement. If the transmitter measurement is based on the maximum conducted output power, the attenuation required under this paragraph shall be 30dB instead of 20dB. In addition, radiated emissions which fall in section 15.205(a) the restricted bands must also comply with the radiated emission limit specified in section 15.209(a).

FREQUENCIES(MHz)	FIELD STRENGTH (microvolts/meter)	MEASUREMENT DISTANCE(meters)
0.009~0.490	2400/F(kHz)	300
0.490~1.705	24000/F(kHz)	30
1.705~30.0	30	30
30~88	100	3
88~216	150	3
216~960	200	3
Above 960	500	3

6.2 Test Procedures

- The EUT was placed on a rotatable table top 0.8 meter for frequency below 1GHz and 1.5meter for frequency above 1GHz above ground.
- The EUT was set 3 meters from the interference receiving antenna which was mounted on the top of a variable height antenna tower.
- The table was rotated 360 degrees to determine the position of the highest radiation.
- The antenna is a broadband antenna and its height is varied between one meter and four meters above ground to find the maximum value of the field strength both horizontal polarization and vertical polarization of the antenna are set to make the measurement.
- For each suspected emission the EUT was arranged to its worst case and then tune the antenna tower (from 1 M to 4 M) and turn table (from 0 degree to 360 degrees) to find the maximum reading.
- Set the test-receiver system to Peak or CISPR quasi-peak Detect Function and specified bandwidth with Maximum Hold Mode.
- If the emission level of the EUT in peak mode was 3 dB lower than the limit specified, then testing will be stopped and peak values of EUT will be reported, otherwise, the emissions which do not have 3 dB margin will be repeated one by one using the quasi-peak method and reported.
- For testing above 1GHz, the emission level of the EUT in peak mode was 20dB lower than AVG limit (that means the emission level in peak mode also complies with the limit in AVG mode), then testing will be stopped and peak values of EUT will be reported, otherwise, the emissions will be measured in AVG mode again and reported.



6.3 Typical Test Setup

Below 30MHz Test Setup

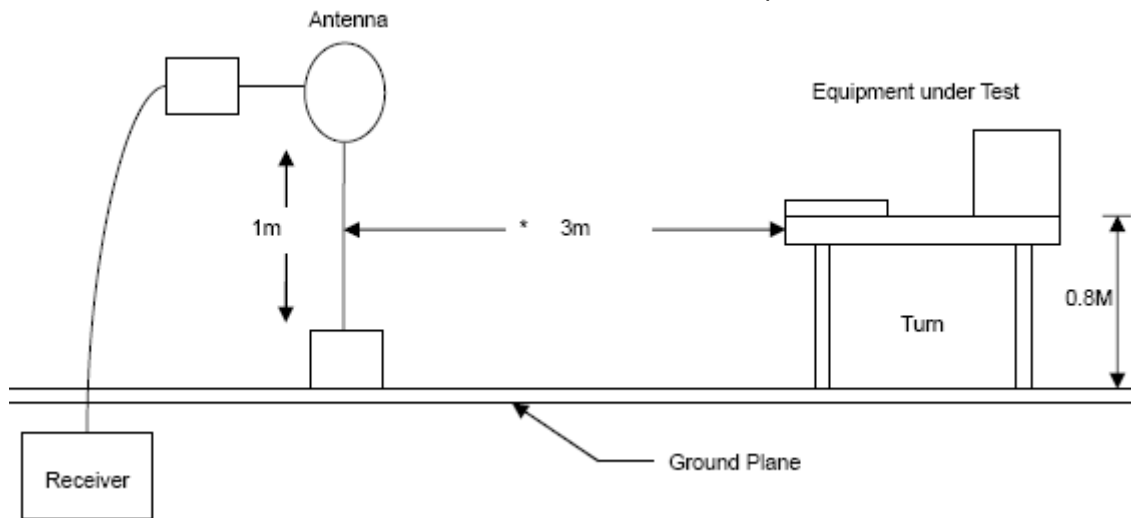

30M - 1GHz Test Setup

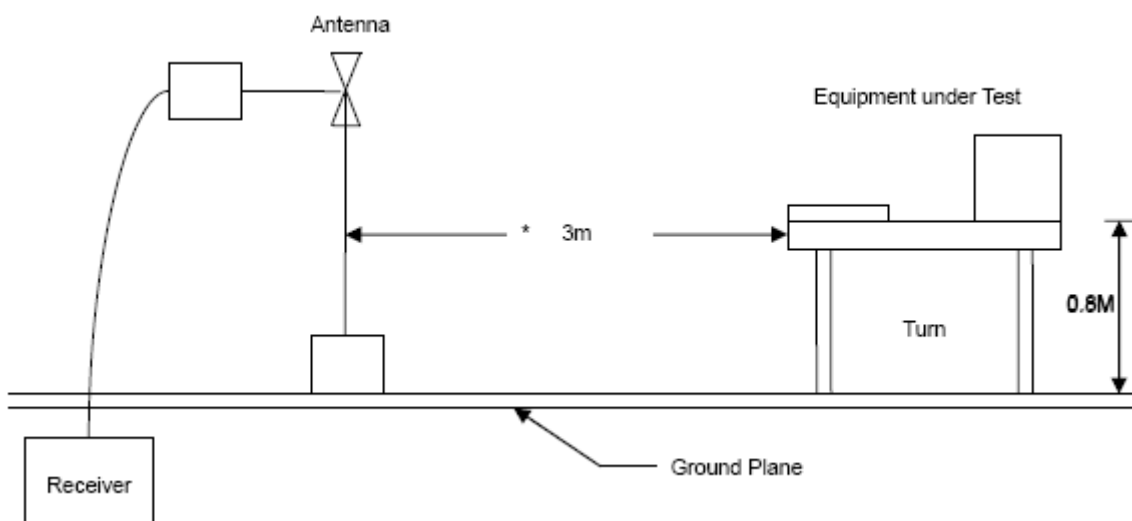

Above 1GHz Test Setup

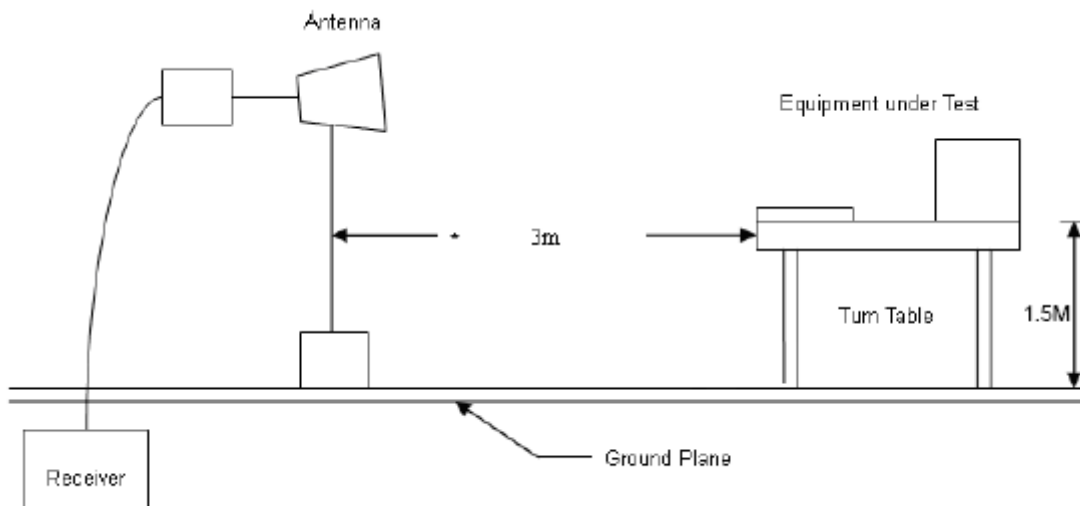

**6.4 Test Result and Data (9KHz ~ 30MHz)**

The 9kHz-30MHz spurious emission is under limit 20dB more.

6.5 Test Result and Data (30MHz ~ 1GHz)

Power	: AC 120V	Temperature	: 24 °C
Test Mode	: Normal Link	Humidity	: 54 %
Test date	: Jul. 23, 2017	Atmospheric Pressure	: 1010 hpa

Frequency (MHz)	AntPol. H/V	Correct Factor (dB)	Reading level (dBuV)	Measure Level (dBuV/m)	Limit 3m (dBuV/m)	Safe Margin (dB)	Detector mode (PK/QP)
31.9400	H	-4.16	31.96	27.80	40.00	-12.20	QP
156.1000	H	-11.77	38.35	26.58	43.50	-16.92	QP
332.6400	H	-4.13	30.98	26.85	46.00	-19.15	QP
400.5400	H	-5.13	30.55	25.42	46.00	-20.58	QP
500.4500	H	-2.20	29.95	27.75	46.00	-18.25	QP
600.3600	H	-1.05	33.13	32.08	46.00	-13.92	QP
144.4600	V	-10.87	43.67	32.80	43.50	-10.70	QP
156.1000	V	-11.77	49.22	37.45	43.50	-6.05	QP
163.8600	V	-12.30	47.35	35.05	43.50	-8.45	QP
327.7900	V	-4.66	30.64	25.98	46.00	-20.02	QP
500.4500	V	-2.20	34.16	31.96	46.00	-14.04	QP
600.3600	V	-1.05	35.60	34.55	46.00	-11.45	QP

Note: Level = Reading + Factor

Margin = Level – Limit

Factor= Antenna Factor + Cable Loss - Amplifier Factor

**6.6 Test Result and Data (1GHz ~ 25GHz)**

Power	: AC 120V	Temperature	: 24 °C
Test Mode	802.11b (2412MHz)	Humidity	: 54 %
Test date	: Jul. 23, 2017	Atmospheric Pressure	: 1010 hpa

Frequency (MHz)	AntPol. H/V	Correct Factor (dB)	Reading level (dBuV)	Measure Level (dBuV/m)	Limit 3m (dBuV/m)	Margin (dB)	Detector mode (PK/QP)
1042.500	H	-0.96	44.56	43.60	74.00	-30.40	peak
1637.500	H	5.20	35.63	40.83	74.00	-33.17	peak
3677.500	H	7.71	34.38	42.09	74.00	-31.91	peak
4825.000	H	8.27	51.27	59.54	74.00	-14.46	peak
4825.000	H	8.27	44.26	52.53	54.00	-1.47	AVG
5675.000	H	9.45	34.40	43.85	74.00	-30.15	peak
6185.000	H	10.33	35.33	45.66	74.00	-28.34	peak
2190.000	V	-3.91	43.56	39.65	74.00	-34.35	peak
3975.000	V	5.02	35.26	40.28	74.00	-33.72	peak
4400.000	V	7.15	36.26	43.41	74.00	-30.59	peak
4910.000	V	8.43	52.41	60.84	74.00	-13.16	peak
4910.000	V	8.43	43.61	52.04	54.00	-1.96	AVG
5420.000	V	8.95	34.75	43.70	74.00	-30.30	peak
6057.500	V	10.28	34.46	44.74	74.00	-29.26	peak

Note: Level = Reading + Factor

Margin = Level – Limit

Factor= Antenna Factor + Cable Loss - Amplifier Factor



Power	: AC 120V	Temperature	: 24 °C
Test Mode	: 802.11b (2437MHz)	Humidity	: 54 %
Test date	: Jul. 23, 2017	Atmospheric Pressure	: 1010 hpa

Frequency (MHz)	AntPol. H/V	Correct Factor (dB)	Reading level (dBuV)	Measure Level (dBuV/m)	Limit 3m (dBuV/m)	Margin (dB)	Detector mode (PK/QP)
2785.000	H	-0.67	44.26	43.59	74.00	-30.41	peak
3975.000	H	5.02	36.21	41.23	74.00	-32.77	peak
4400.000	H	7.15	35.72	42.87	74.00	-31.13	peak
4910.000	H	8.43	50.69	59.12	74.00	-14.88	peak
4910.000	H	8.43	43.43	51.86	54.00	-2.14	AVG
5717.500	H	9.56	34.27	43.83	74.00	-30.17	peak
6397.500	H	10.42	35.08	45.50	74.00	-28.50	peak
2742.500	V	-0.96	44.10	43.14	74.00	-30.86	peak
3465.000	V	3.22	37.02	40.24	74.00	-33.76	peak
4145.000	V	5.85	36.75	42.60	74.00	-31.40	peak
4910.000	V	8.43	50.41	58.84	74.00	-15.16	peak
4910.000	V	8.43	42.69	51.12	54.00	-2.88	AVG
6142.500	V	10.32	35.25	45.57	74.00	-28.43	peak
6737.500	V	11.23	36.10	47.33	74.00	-26.67	peak

Note: Level = Reading + Factor

Margin = Level – Limit

Factor= Antenna Factor + Cable Loss - Amplifier Factor



Power	: AC 120V	Temperature	: 24 °C
Test Mode	: 802.11b (2462MHz)	Humidity	: 54 %
Test date	: Jul. 23, 2017	Atmospheric Pressure	: 1010 hpa

Frequency (MHz)	AntPol. H/V	Correct Factor (dB)	Reading level (dBuV)	Measure Level (dBuV/m)	Limit 3m (dBuV/m)	Margin (dB)	Detector mode (PK/QP)
2870.000	H	-0.10	45.88	45.78	74.00	-28.22	peak
3720.000	H	4.15	39.19	43.34	74.00	-30.66	peak
4272.500	H	6.50	37.95	44.45	74.00	-29.55	peak
4952.500	H	8.51	48.98	57.49	74.00	-16.51	peak
4952.500	H	8.51	43.21	51.72	54.00	-2.28	AVG
5845.000	H	9.88	36.35	46.23	74.00	-27.77	peak
6355.000	H	10.40	36.44	46.84	74.00	-27.16	peak
1680.000	V	-6.57	47.64	41.07	74.00	-32.93	peak
3762.500	V	4.30	36.67	40.97	74.00	-33.03	peak
4485.000	V	7.58	36.50	44.08	74.00	-29.92	peak
4952.500	V	8.51	48.26	56.77	74.00	-17.23	peak
4952.500	V	8.51	41.83	50.34	54.00	-3.66	AVG
5505.000	V	9.03	36.87	45.90	74.00	-28.10	peak
6185.000	V	10.33	35.62	45.95	74.00	-28.05	peak

Note: Level = Reading + Factor

Margin = Level – Limit

Factor= Antenna Factor + Cable Loss - Amplifier Factor



Power	: AC 120V	Temperature	: 24 °C
Test Mode	: 802.11g (2412MHz)	Humidity	: 54 %
Test date	: Jul. 23, 2017	Atmospheric Pressure	: 1010 hpa

Frequency (MHz)	AntPol. H/V	Correct Factor (dB)	Reading level (dBuV)	Measure Level (dBuV/m)	Limit 3m (dBuV/m)	Margin (dB)	Detector mode (PK/QP)
3380.000	H	2.77	37.64	40.41	74.00	-33.59	peak
4017.500	H	5.20	35.79	40.99	74.00	-33.01	peak
4570.000	H	7.79	36.10	43.89	74.00	-30.11	peak
4825.000	H	8.27	56.35	64.62	74.00	-9.38	peak
4825.000	H	8.27	40.59	48.86	54.00	-5.14	AVG
5717.500	H	9.56	36.09	45.65	74.00	-28.35	peak
6227.500	H	10.35	35.29	45.64	74.00	-28.36	peak
2105.000	V	-4.28	44.69	40.41	74.00	-33.59	peak
3762.500	V	4.30	36.87	41.17	74.00	-32.83	peak
4187.500	V	6.07	36.56	42.63	74.00	-31.37	peak
4867.500	V	8.35	52.27	60.62	74.00	-13.38	peak
4867.500	V	8.35	38.67	47.02	54.00	-6.98	AVG
5845.000	V	9.88	34.96	44.84	74.00	-29.16	peak
6695.000	V	11.09	35.36	46.45	74.00	-27.55	peak

Note: Level = Reading + Factor
Margin = Level – Limit
Factor= Antenna Factor + Cable Loss - Amplifier Factor



Power	: AC 120V	Temperature	: 24 °C
Test Mode	: 802.11g (2437MHz)	Humidity	: 54 %
Test date	: Jul. 23, 2017	Atmospheric Pressure	: 1010 hpa

Frequency (MHz)	AntPol. H/V	Correct Factor (dB)	Reading level (dBuV)	Measure Level (dBuV/m)	Limit 3m (dBuV/m)	Margin (dB)	Detector mode (PK/QP)
3465.000	H	3.22	37.10	40.32	74.00	-33.68	peak
4272.500	H	6.50	36.64	43.14	74.00	-30.86	peak
4910.000	H	8.43	53.99	62.42	74.00	-11.58	peak
4910.000	H	8.43	39.27	47.70	54.00	-6.30	AVG
5377.500	H	8.92	35.12	44.04	74.00	-29.96	peak
5590.000	H	9.24	35.61	44.85	74.00	-29.15	peak
6312.500	H	10.38	35.55	45.93	74.00	-28.07	peak
3210.000	V	1.87	38.11	39.98	74.00	-34.02	peak
3847.500	V	4.59	36.88	41.47	74.00	-32.53	peak
4230.000	V	6.28	36.09	42.37	74.00	-31.63	peak
4910.000	V	8.43	52.73	61.16	74.00	-12.84	peak
4910.000	V	8.43	38.21	46.64	54.00	-7.36	AVG
5207.500	V	8.77	35.66	44.43	74.00	-29.57	peak
5972.500	V	10.19	35.62	45.81	74.00	-28.19	peak

Note: Level = Reading + Factor

Margin = Level – Limit

Factor= Antenna Factor + Cable Loss - Amplifier Factor



Power	: AC 120V	Temperature	: 24 °C
Test Mode	: 802.11g (2462MHz)	Humidity	: 54 %
Test date	: Jul. 23, 2017	Atmospheric Pressure	: 1010 hpa

Frequency (MHz)	AntPol. H/V	Correct Factor (dB)	Reading level (dBuV)	Measure Level (dBuV/m)	Limit 3m (dBuV/m)	Margin (dB)	Detector mode (PK/QP)
2657.500	H	-1.52	43.77	42.25	74.00	-31.75	peak
4145.000	H	5.85	36.05	41.90	74.00	-32.10	peak
4570.000	H	7.79	35.98	43.77	74.00	-30.23	peak
4952.500	H	8.51	52.85	61.36	74.00	-12.64	peak
4952.500	H	8.51	38.16	46.67	54.00	-7.33	AVG
5802.500	H	9.77	35.20	44.97	74.00	-29.03	peak
6227.500	H	10.35	35.53	45.88	74.00	-28.12	peak
3592.500	V	3.72	37.91	41.63	74.00	-32.37	peak
4187.500	V	6.07	36.60	42.67	74.00	-31.33	peak
4952.500	V	8.51	53.28	61.79	74.00	-12.21	peak
4952.500	V	8.51	38.51	47.02	54.00	-6.98	AVG
5292.500	V	8.85	34.06	42.91	74.00	-31.09	peak
5590.000	V	9.24	35.26	44.50	74.00	-29.50	peak
6355.000	V	10.40	35.58	45.98	74.00	-28.02	peak

Note: Level = Reading + Factor

Margin = Level – Limit

Factor= Antenna Factor + Cable Loss - Amplifier Factor



Power	: AC 120V	Temperature	: 24 °C
Test Mode	: 802.11n HT20 (2412MHz)	Humidity	: 54 %
Test date	: Jul. 23, 2017	Atmospheric Pressure	: 1010 hpa

Frequency (MHz)	AntPol. H/V	Correct Factor (dB)	Reading level (dBuV)	Measure Level (dBuV/m)	Limit 3m (dBuV/m)	Margin (dB)	Detector mode (PK/QP)
2700.000	H	-1.24	44.31	43.07	74.00	-30.93	peak
3507.500	H	3.43	36.86	40.29	74.00	-33.71	peak
3975.000	H	5.02	35.65	40.67	74.00	-33.33	peak
4825.000	H	8.27	54.35	62.62	74.00	-11.38	peak
4825.000	H	8.27	39.67	47.94	54.00	-6.06	AVG
5972.500	H	10.19	34.23	44.42	74.00	-29.58	peak
6482.500	H	10.45	35.36	45.81	74.00	-28.19	peak
2785.000	V	-0.67	45.27	44.60	74.00	-29.40	peak
3550.000	V	3.57	36.40	39.97	74.00	-34.03	peak
4230.000	V	6.28	35.45	41.73	74.00	-32.27	peak
4867.500	V	8.35	52.77	61.12	74.00	-12.88	peak
4867.500	V	8.35	37.95	46.30	54.00	-7.70	AVG
5462.500	V	8.99	35.35	44.34	74.00	-29.66	peak
5972.500	V	10.19	34.98	45.17	74.00	-28.83	peak

Note: Level = Reading + Factor
Margin = Level – Limit
Factor= Antenna Factor + Cable Loss - Amplifier Factor



Power	: AC 120V	Temperature	: 24 °C
Test Mode	: 802.11n HT20 (2437MHz)	Humidity	: 54 %
Test date	: Jul. 23, 2017	Atmospheric Pressure	: 1010 hpa

Frequency (MHz)	AntPol. H/V	Correct Factor (dB)	Reading level (dBuV)	Measure Level (dBuV/m)	Limit 3m (dBuV/m)	Margin (dB)	Detector mode (PK/QP)
2742.500	H	-0.96	43.69	42.73	74.00	-31.27	peak
3975.000	H	5.02	36.59	41.61	74.00	-32.39	peak
4612.500	H	7.87	34.63	42.50	74.00	-31.50	peak
4910.000	H	8.43	55.49	63.92	74.00	-10.08	peak
4910.000	H	8.43	40.06	48.49	54.00	-5.51	AVG
5845.000	H	9.88	34.60	44.48	74.00	-29.52	peak
6780.000	H	11.37	35.92	47.29	74.00	-26.71	peak
2785.000	V	-0.67	44.60	43.93	74.00	-30.07	peak
3465.000	V	3.22	36.60	39.82	74.00	-34.18	peak
4485.000	V	7.58	35.14	42.72	74.00	-31.28	peak
4910.000	V	8.43	54.73	63.16	74.00	-10.84	peak
4910.000	V	8.43	38.92	47.35	54.00	-6.65	AVG
5887.500	V	9.98	34.81	44.79	74.00	-29.21	peak
6780.000	V	11.37	36.03	47.40	74.00	-26.60	peak

Note: Level = Reading + Factor

Margin = Level – Limit

Factor= Antenna Factor + Cable Loss - Amplifier Factor



Power	: AC 120V	Temperature	: 24 °C
Test Mode	: 802.11n HT20(2462MHz)	Humidity	: 54 %
Test date	: Jul. 23, 2017	Atmospheric Pressure	: 1010 hpa

Frequency (MHz)	AntPol. H/V	Correct Factor (dB)	Reading level (dBuV)	Measure Level (dBuV/m)	Limit 3m (dBuV/m)	Margin (dB)	Detector mode (PK/QP)
2742.500	H	-0.96	43.89	42.93	74.00	-31.07	peak
3720.000	H	4.15	36.44	40.59	74.00	-33.41	peak
4570.000	H	7.79	35.98	43.77	74.00	-30.23	peak
4952.500	H	8.51	54.35	62.86	74.00	-11.14	peak
4952.500	H	8.51	39.17	47.68	54.00	-6.32	AVG
5845.000	H	9.88	34.68	44.56	74.00	-29.44	peak
6695.000	H	11.09	35.25	46.34	74.00	-27.66	peak
2700.000	V	-1.24	44.74	43.50	74.00	-30.50	peak
3507.500	V	3.43	36.01	39.44	74.00	-34.56	peak
4612.500	V	7.87	35.23	43.10	74.00	-30.90	peak
4952.500	V	8.51	52.78	61.29	74.00	-12.71	peak
4952.500	V	8.51	37.64	46.15	54.00	-7.85	AVG
6057.500	V	10.28	34.56	44.84	74.00	-29.16	peak
6652.500	V	10.95	34.20	45.15	74.00	-28.85	peak

Note: Level = Reading + Factor

Margin = Level – Limit

Factor= Antenna Factor + Cable Loss - Amplifier Factor



6.7 Restricted Bands of Operation

Only spurious emissions are permitted in any of the frequency bands listed below:

MHz	MHz	MHz	GHz
0.09000 – 0.11000	16.42000 – 16.42300	399.9 – 410.0	4.500 – 5.250
0.49500 – 0.505**	16.69475 – 16.69525	608.0 – 614.0	5.350 – 5.460
2.17350 – 2.19050	16.80425 – 16.80475	960.0 – 1240.0	7.250 – 7.750
4.12500 – 4.12800	25.50000 – 25.67000	1300.0 – 1427.0	8.025 – 8.500
4.17725 – 4.17775	37.50000 – 38.25000	1435.0 – 1626.5	9.000 – 9.200
4.20725 – 4.20775	73.00000 – 74.60000	1645.5 – 1646.5	9.300 – 9.500
6.21500 – 6.21800	74.80000 – 75.20000	1660.0 – 1710.0	10.600 – 12.700
6.26775 – 6.26825	108.00000 – 121.94000	1718.8 – 1722.2	13.250 – 13.400
6.31175 – 6.31225	123.00000 – 138.00000	2200.0 – 2300.0	14.470 – 14.500
8.29100 – 8.29400	149.90000 – 150.05000	2310.0 – 2390.0	15.350 – 16.200
8.36200 – 8.36600	156.52475 – 156.52525	2483.5 – 2500.0	17.700 – 21.400
8.37625 – 8.38675	156.70000 – 156.90000	2655.0 – 2900.0	22.010 – 23.120
8.41425 – 8.41475	162.01250 – 167.17000	3260.0 – 3267.0	23.600 – 24.000
12.29000 – 12.29300	167.72000 – 173.20000	3332.0 – 3339.0	31.200 – 31.800
12.51975 – 12.52025	240.00000 – 285.00000	3345.8 – 3358.0	36.430 – 36.500
12.57675 – 12.57725	322.00000 – 335.40000	3600.0 – 4400.0	Above 38.6
13.36000 – 13.41000			

** : Until February 1, 1999, this restricted band shall be 0.490-0.510 MHz



6.8 Restrict Band Emission Measurement Data

Test Date: Jul. 23, 2017

Temperature: 26°C

Atmospheric pressure: 1018 hPa

Humidity: 47%

Modulation Standard: 802.11b

Channel 1				Fundamental Frequency: 2412 MHz			
Frequency (MHz)	Factor (dB/m)	Reading (dBuV)	Level (dBuV/m)	Limit (dBuV/m)	Margin (dB)	Det.	Ant-Pol H/V
2387.375	-3.06	59.55	56.49	74.00	-17.51	peak	H
2387.375	-3.06	44.27	41.21	54.00	-12.79	AVG	H
2390.000	-3.05	56.49	53.44	74.00	-20.56	peak	H
2390.000	-3.05	41.61	38.56	54.00	-15.44	AVG	H
2387.375	-3.06	56.28	53.22	74.00	-20.78	peak	V
2387.375	-3.06	41.67	38.61	54.00	-15.39	AVG	V
2390.000	-3.05	52.08	49.03	74.00	-24.97	peak	V
2390.000	-3.05	35.63	32.58	54.00	-21.42	AVG	V
Channel 11				Fundamental Frequency: 2462 MHz			
2483.500	-2.65	49.06	46.41	74.00	-27.59	peak	H
2483.500	-2.65	34.27	31.62	54.00	-22.38	AVG	H
2483.500	-2.65	47.04	44.39	74.00	-29.61	peak	V
2483.500	-2.65	32.61	29.96	54.00	-24.04	AVG	V

Modulation Standard: 802.11g

Channel 1				Fundamental Frequency: 2412 MHz			
Frequency (MHz)	Factor (dB/m)	Reading (dBuV)	Level (dBuV/m)	Limit (dBuV/m)	Margin (dB)	Det.	Ant-Pol H/V
2390.000	-3.05	68.70	65.65	74.00	-8.35	peak	H
2390.000	-3.05	49.67	46.62	54.00	-7.38	AVG	H
2390.000	-3.05	60.12	57.07	74.00	-16.93	peak	V
2390.000	-3.05	42.67	39.62	54.00	-14.38	AVG	V
Channel 11				Fundamental Frequency: 2462 MHz			
2483.500	-2.65	71.03	68.38	74.00	-5.62	peak	H
2483.500	-2.65	53.21	50.56	54.00	-3.44	AVG	H
2483.500	-2.65	59.30	56.65	74.00	-17.35	peak	V
2483.500	-2.65	42.62	39.97	54.00	-14.03	AVG	V



Modulation Standard: 802.11n HT20

Channel 1				Fundamental Frequency: 2412 MHz			
Frequency (MHz)	Factor (dB/m)	Reading (dBuV)	Level (dBuV/m)	Limit (dBuV/m)	Margin (dB)	Det.	Ant-Pol H/V
2390.000	-3.05	75.16	72.11	74.00	-1.89	peak	H
2390.000	-3.05	55.01	51.96	54.00	-2.04	AVG	H
2390.000	-3.05	65.24	62.19	74.00	-11.81	peak	V
2390.000	-3.05	48.67	45.62	54.00	-8.38	AVG	V
Channel 11				Fundamental Frequency: 2462 MHz			
2483.500	-2.65	74.87	72.22	74.00	-1.78	peak	H
2483.500	-2.65	54.29	51.64	54.00	-2.36	AVG	H
2483.500	-2.65	63.30	60.65	74.00	-13.35	peak	V
2483.500	-2.65	45.98	43.33	54.00	-10.67	AVG	V

Notes:

1. Result = Meter Reading + Factor
2. Factor = Antenna Factor + Cable Loss – Amplifier
3. The resolution bandwidth of test receiver/spectrum analyzer is 1MHz and video bandwidth is 3 MHz (detector peak mode) for Peak detection at frequency above 1GHz.
4. The resolution bandwidth of test receiver/spectrum analyzer is 1MHz and video bandwidth is 3 MHz (detector sample mode) for Average detection at frequency above 1GHz.



7. Test of Spurious Emission (Conducted)

7.1 Test Limit

Below 30dB of the highest emission level of operating band (In 100 kHz Resolution Bandwidth)

7.2 Test Procedure

KDB 558074 D01v03r02 - Section 11.2 & Section 11.3

1. Reference level measurement

- (a) Set instrument center frequency to DTS channel center frequency
- (b) Set the span to ≥ 1.5 times the DTS bandwidth
- (c) Set the RBW = 100 kHz
- (d) Set the VBW $\geq 3 \times$ RBW
- (e) Detector = peak
- (f) Sweep time = auto couple
- (g) Trace mode = max hold
- (h) Allow trace to fully stabilize

2. Emission level measurement

- (a) Set the center frequency and span to encompass frequency range to be measured
- (b) RBW = 100kHz
- (c) VBW = 300kHz
- (d) Detector = Peak
- (e) Trace mode = max hold
- (f) Sweep time = auto couple
- (g) The trace was allowed to stabilize

7.3 Test Setup Layout

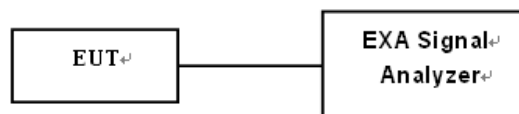



7.4 Test Result and Data

Test Date: Jul. 22, 2017

Temperature: 24°C

Atmospheric pressure: 1014 hPa

Humidity: 47%

Modulation Standard	Frequency (MHz)	Test Result
802.11b	2412	Pass
	2437	Pass
	2462	Pass
802.11g	2412	Pass
	2437	Pass
	2462	Pass
802.11n HT20	2412	Pass
	2437	Pass
	2462	Pass
802.11n HT40	2422	Pass
	2437	Pass
	2452	Pass

Note: Test plots refer to the following pages.



Modulation Type: 802.11b
CH01

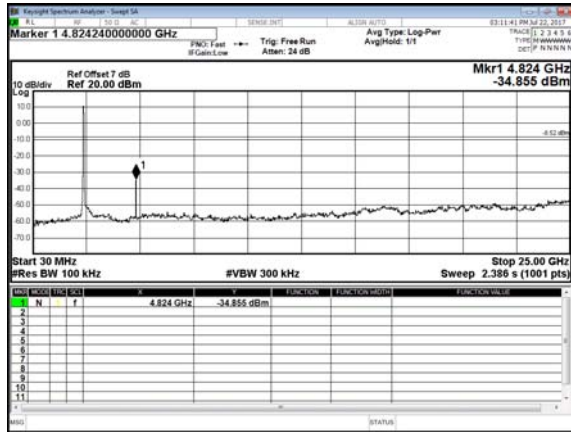
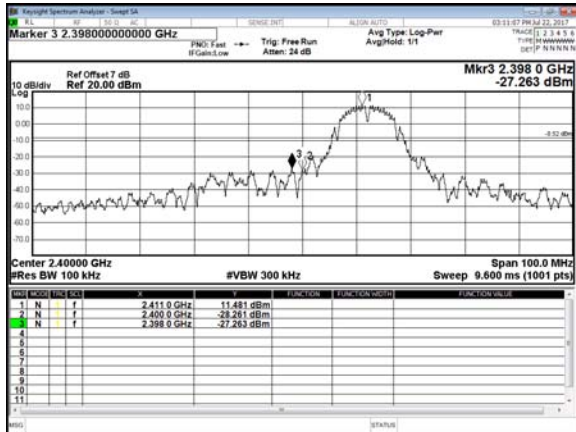

CH06

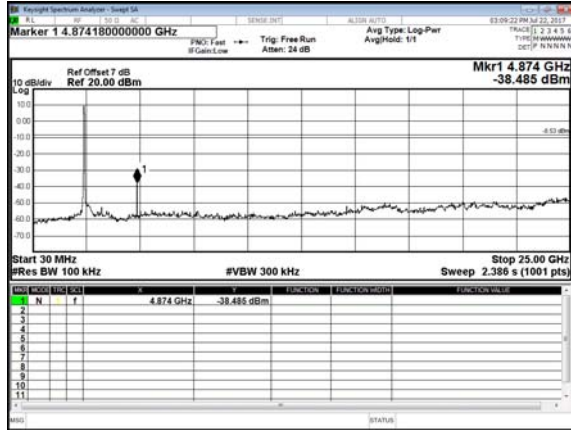
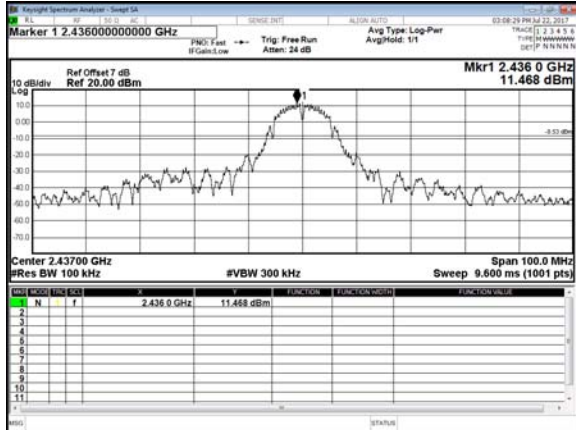

CH11

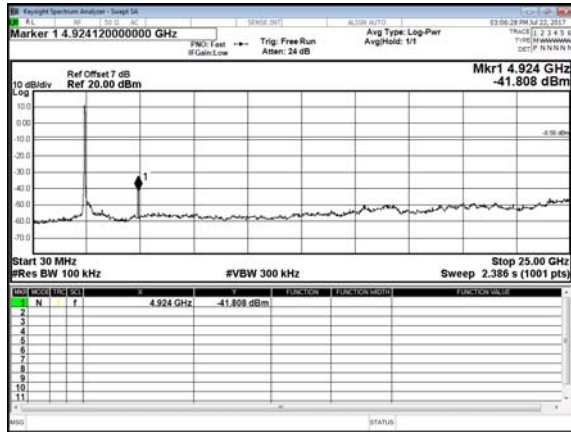
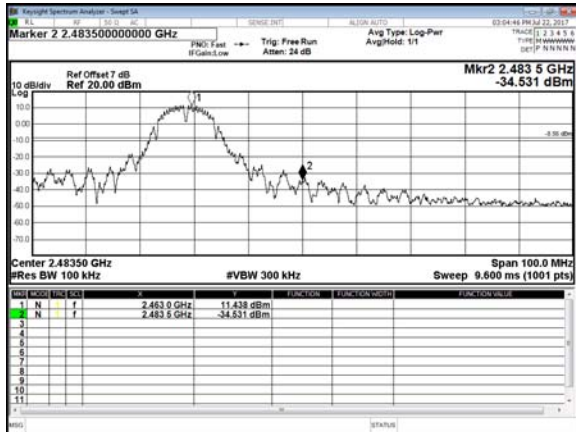



Modulation Type: 802.11g
CH01

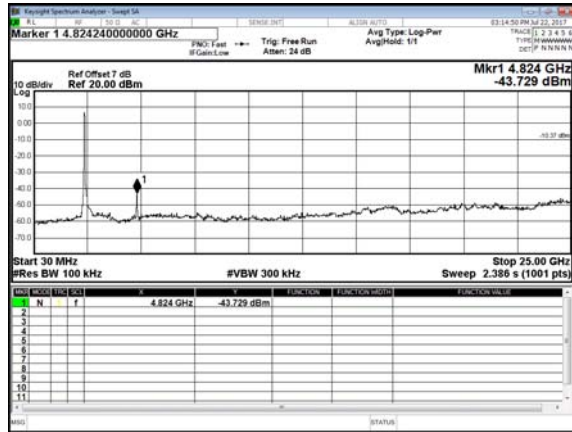
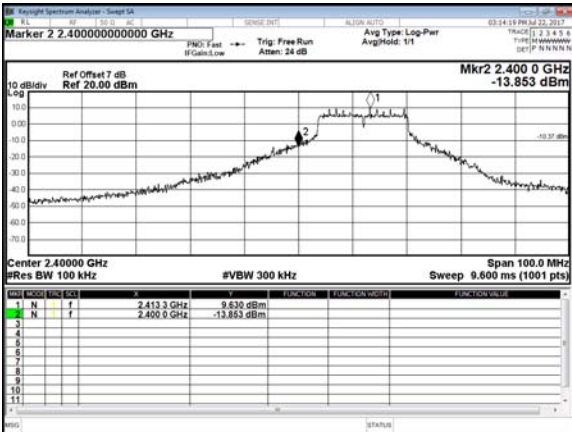

CH06

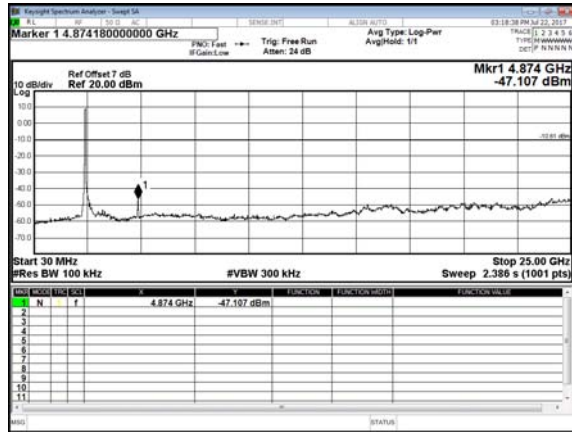
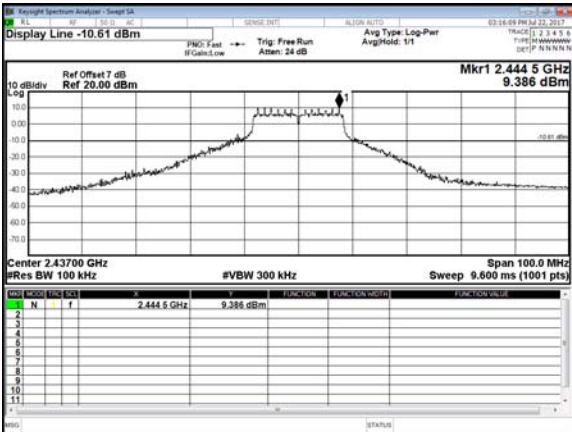

CH11

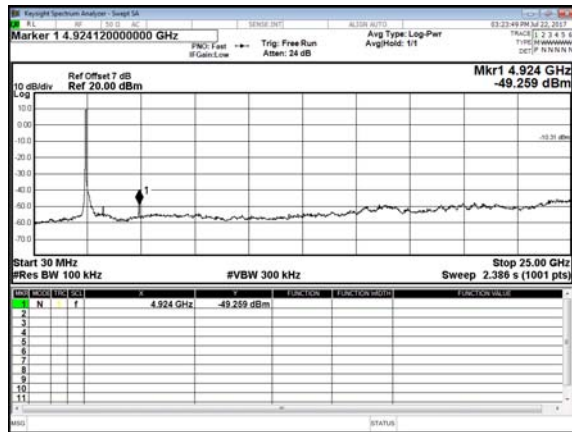
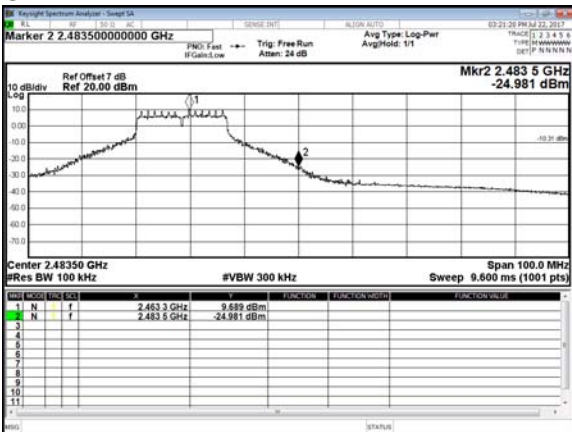



Modulation Type: 802.11n HT20
CH01

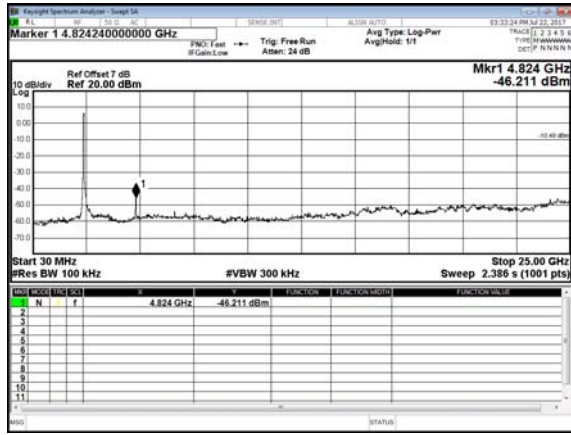
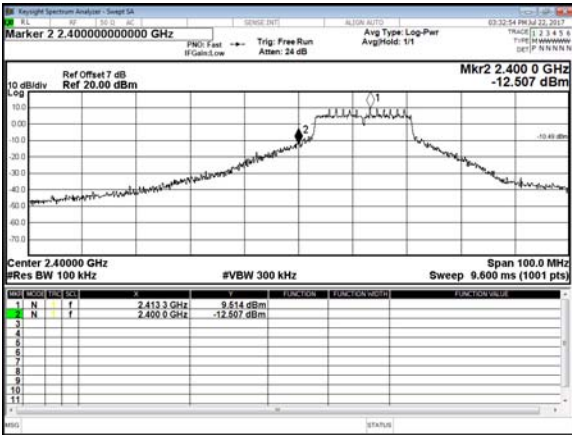

CH06

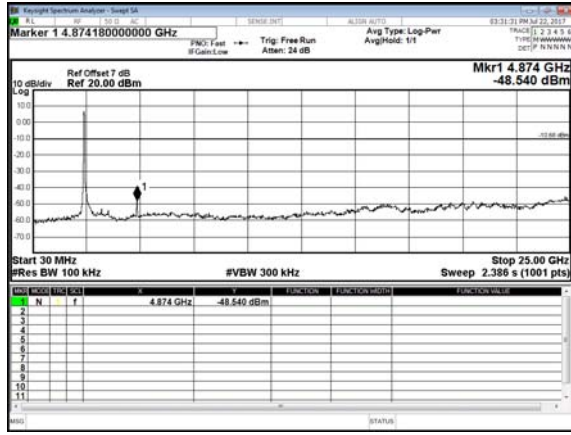
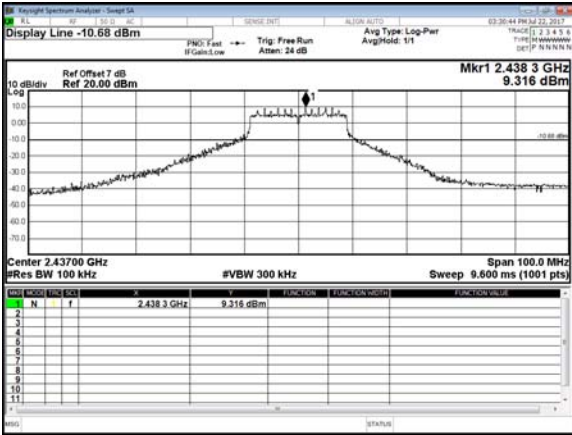

CH11

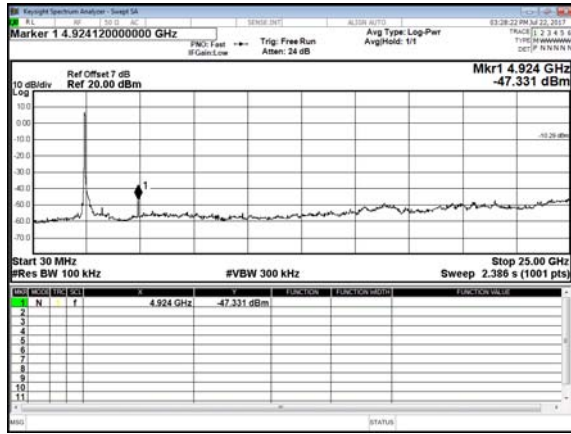
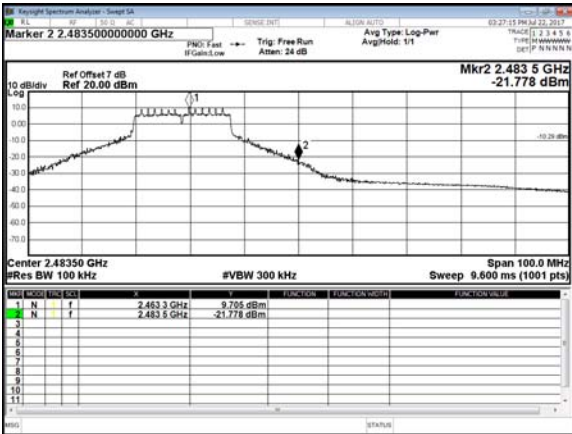



8. 6dB Bandwidth & 99% Bandwidth

8.1 Test Limit

According to §15.247(a)(2), Systems using digital modulation techniques may operate in the 902 - 928 MHz, 2400 - 2483.5 MHz, and 5725 - 5850 MHz bands. The minimum 6 dB bandwidth shall be at least 500kHz.

According to RSS-247 RSS-247 5.2 (a)

(1) The minimum 6 dB bandwidth shall be 500 kHz.

8.2 Test Procedures

- a. The transmitter output was connected to the spectrum analyzer.
- b. Set RBW of spectrum analyzer to 100KHz and $VBW \geq 3x RBW$.
- c. The 6 dB bandwidth is defined as the total spectrum the power of which is higher than peak power minus 6 dB.
- d. The 6dB Bandwidth was measured and recorded.

8.3 Test Setup Layout





8.4 Test Result and Data

Test Mode	Transmit by 802.11b
Test Date	2017-07-22

Channel No.	Frequency (MHz)	6dB Bandwidth (MHz)	99% Bandwidth (MHz)	Result
01	2412	8.148	11.67	Pass
06	2437	8.152	11.88	Pass
11	2462	8.595	11.27	Pass

6dB Bandwidth

Channel 01 (2412MHz)

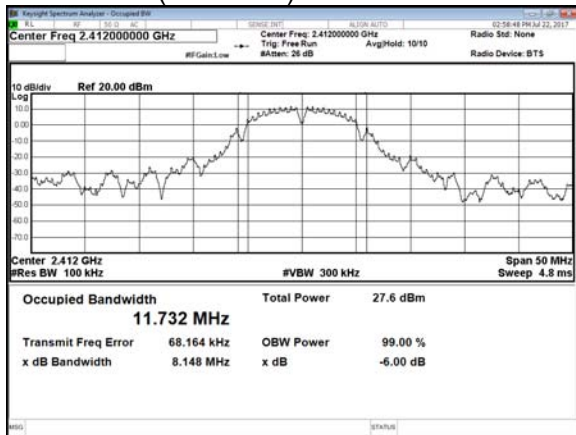

Channel 06 (2437MHz)

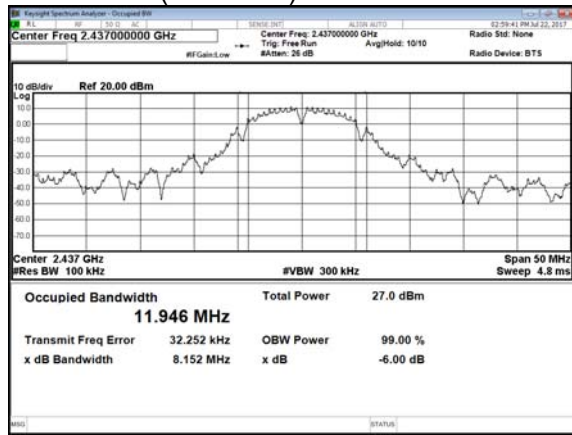

Channel 11 (2462MHz)

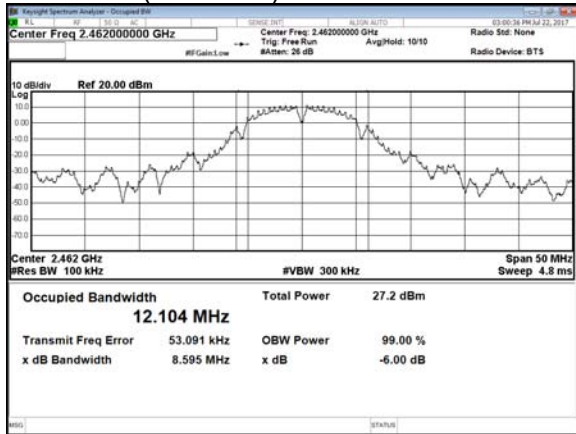



99% Bandwidth

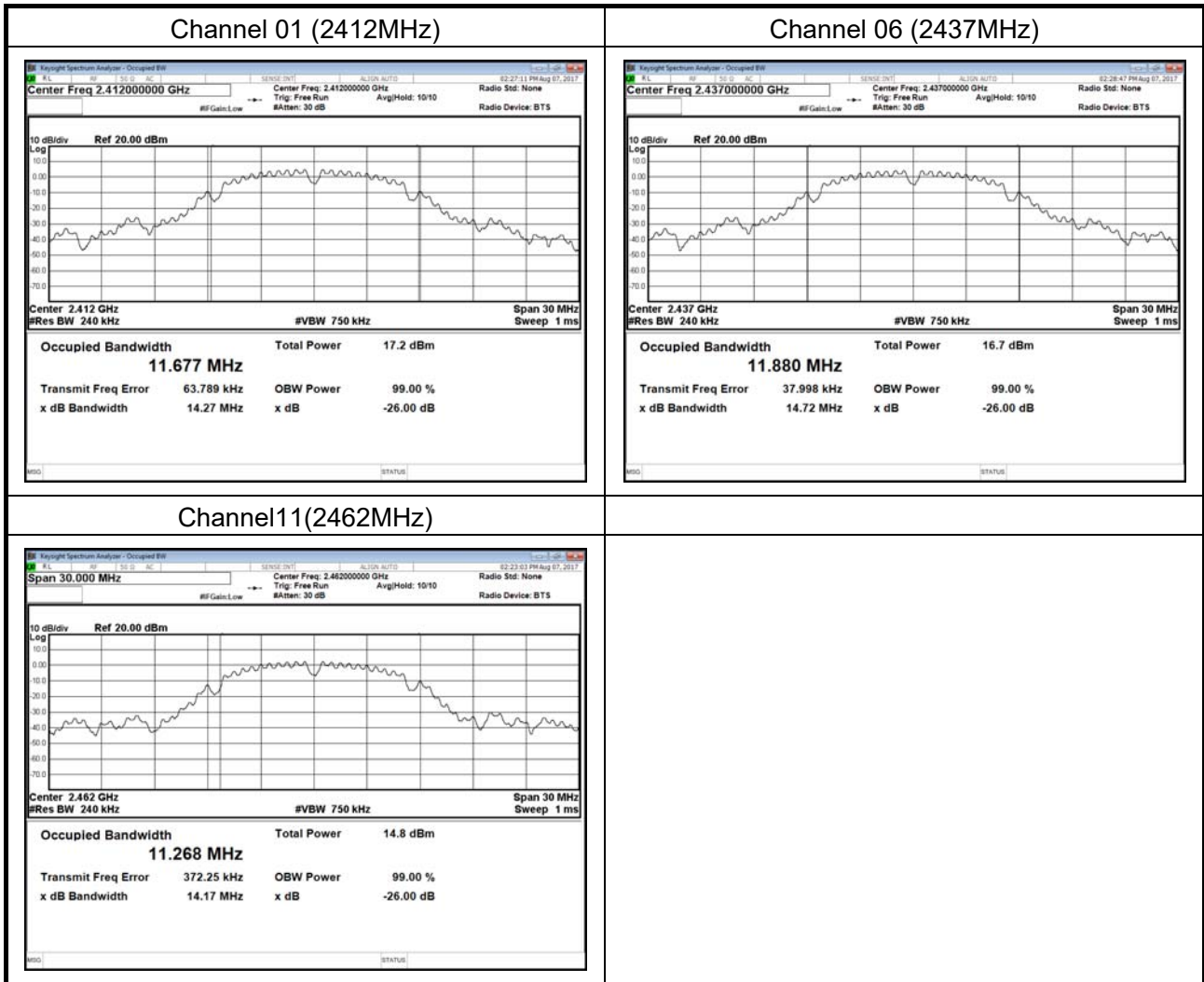



Test Mode	Transmit by 802.11g
Test Date	2017-07-22

Channel No.	Frequency (MHz)	6dB Bandwidth (MHz)	99% Bandwidth (MHz)	Result
01	2412	16.390	20.35	Pass
06	2437	16.390	21.11	Pass
11	2462	16.400	20.10	Pass

6dB Bandwidth

Channel 01 (2412MHz)

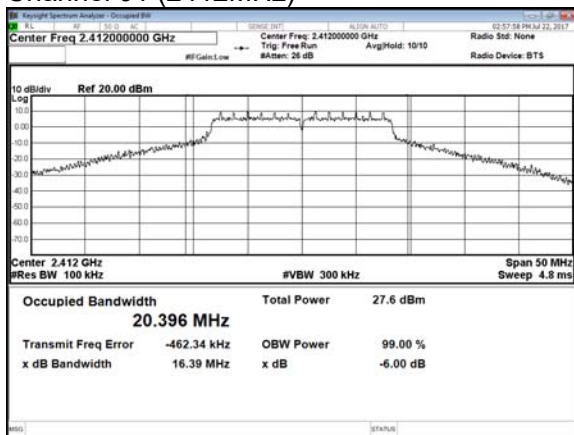

Channel 06 (2437MHz)

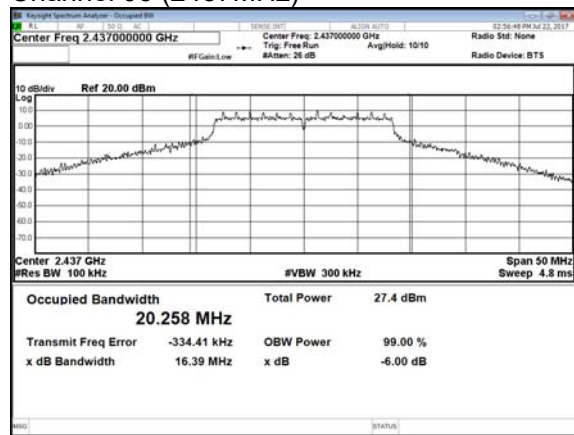

Channel 11 (2462MHz)

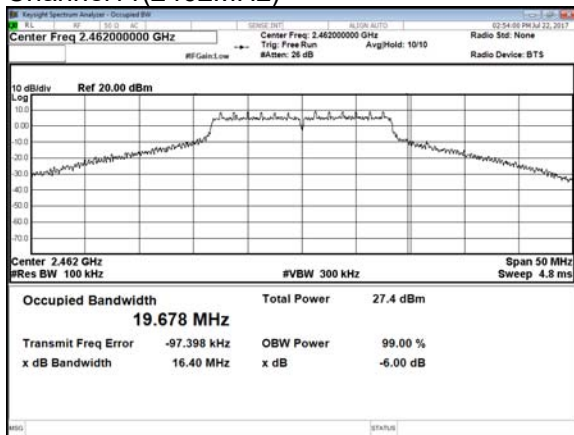



99% Bandwidth

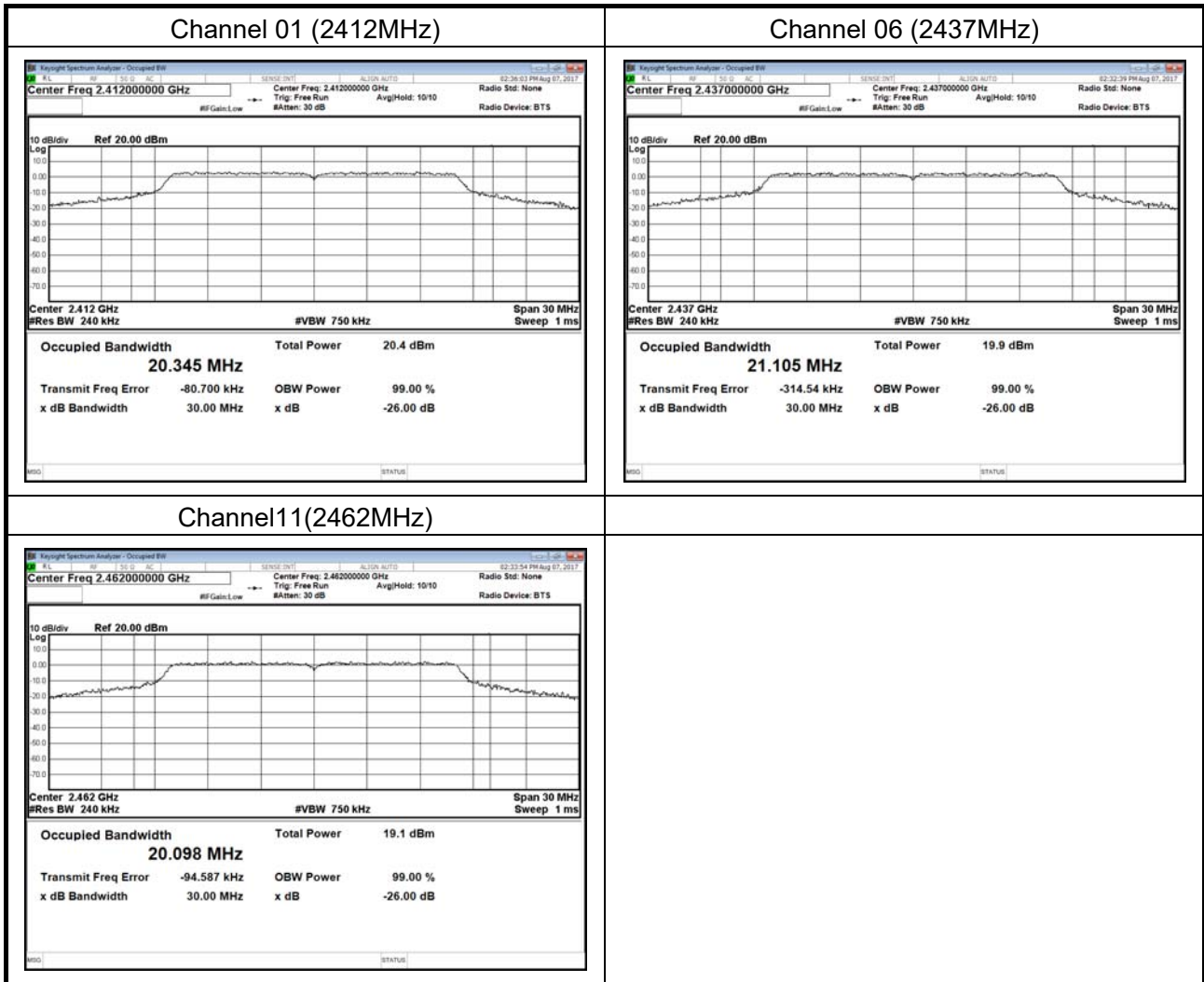



Test Mode	Transmit by 802.11n (20MHz)
Test Date	2017-07-22

Channel No.	Frequency (MHz)	6dB Bandwidth (MHz)	99% Bandwidth (MHz)	Result
01	2412	17.650	20.59	Pass
06	2437	17.660	21.13	Pass
11	2462	17.620	21.16	Pass

6dB Bandwidth

Channel 01 (2412MHz)

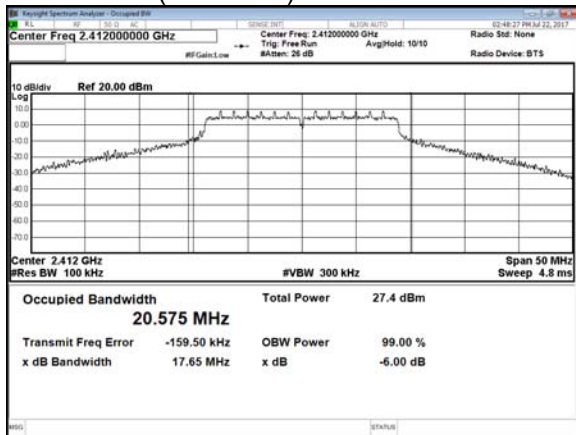

Channel 06 (2437MHz)

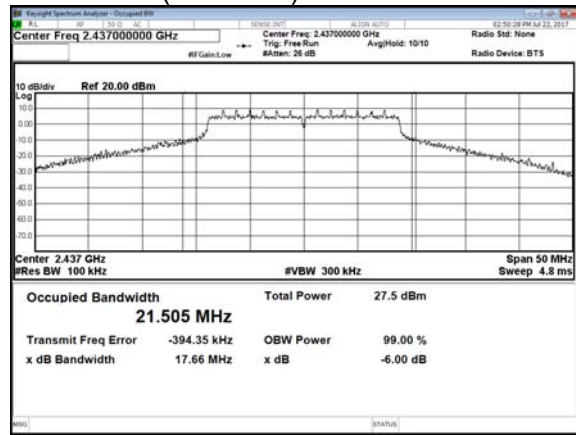

Channel11(2462MHz)

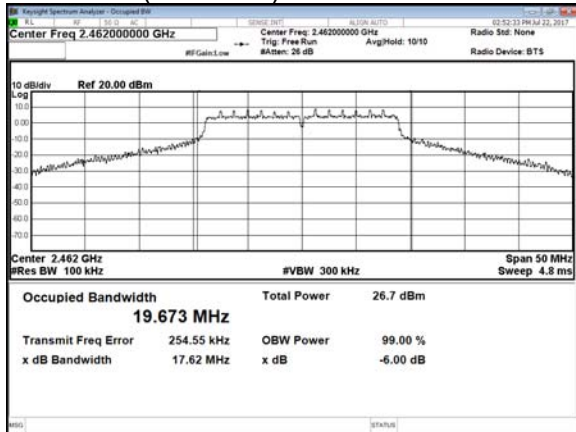



99% Bandwidth

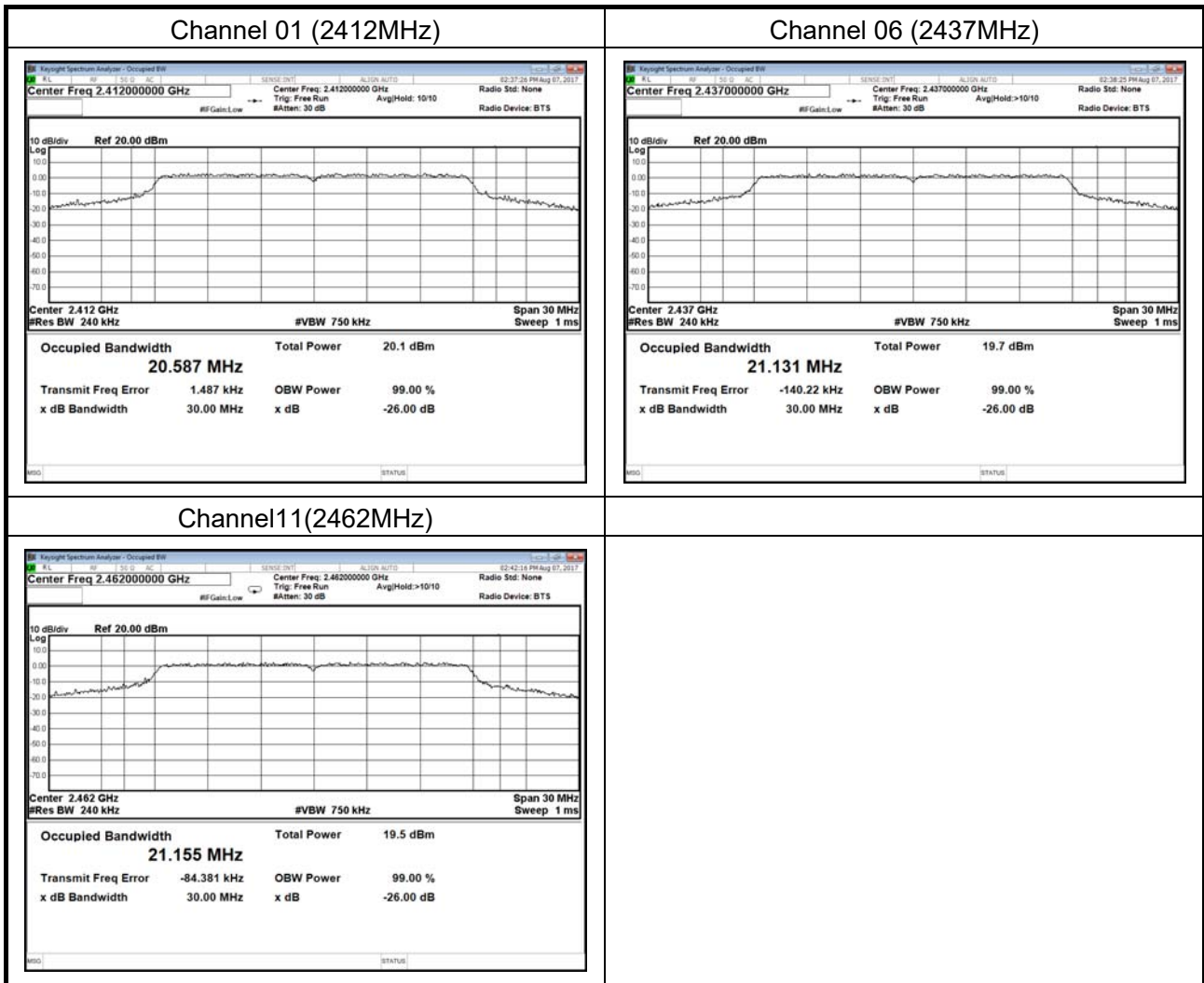



9. Maximum Peak Output Power

9.1 Test Limit

The Maximum Peak Output Power Measurement is 30dBm.

9.2 Test Procedures

Test procedure refers to KDB558074 D01v03r05, section 9.1.2 PKPM1 Peak power meter method.

The antenna port (RF output) of the EUT was connected to the input (RF input) of a power meter. Power was read directly from the meter and cable loss connection was added to the reading to obtain power at the EUT antenna terminal. The EUT Output Power was set to maximum to produce the worse case test result.

9.3 Test Setup Layout

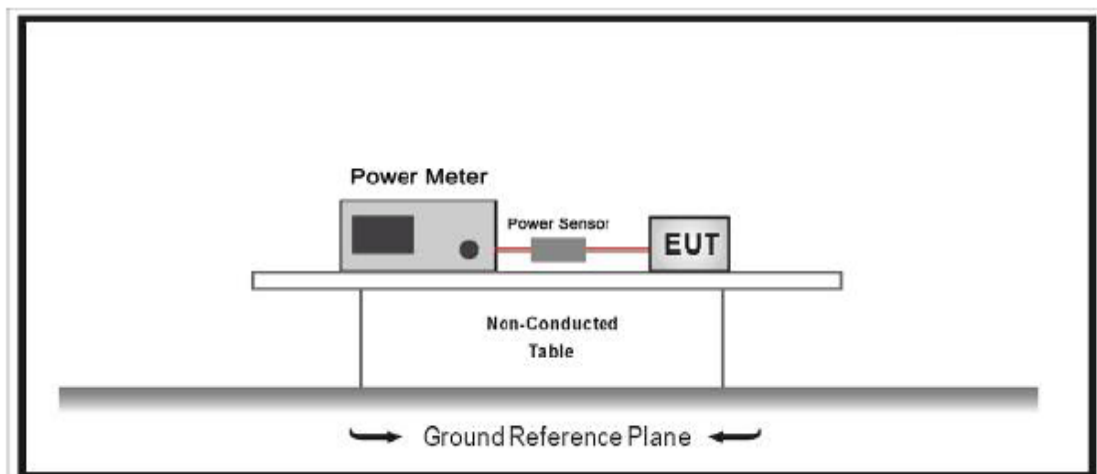



9.4 Test Result and Data

Test Date: Jul. 23, 2017

Temperature: 24°C

Atmospheric pressure: 1016 hPa

Humidity: 46%

Modulation Type	Channel	Frequency (MHz)	Peak Power Output (dBm)	Peak Power Output (mW)
IEEE 802.11b	01	2412	22.55	179.887
	06	2437	21.40	138.038
	11	2462	21.08	128.233
IEEE 802.11g	01	2412	28.26	669.885
	06	2437	27.54	567.545
	11	2462	27.08	510.505
IEEE 802.11n HT20	01	2412	27.90	616.595
	06	2437	28.00	630.957
	11	2462	27.24	529.663



10. Power Spectral Density

10.1 Test Limit

The Maximum of Power Spectral Density Measurement is 8dBm.

10.2 Test Procedures

Test procedure refers to section 10.3 Method AVGPSD-1.

- a) Set instrument center frequency to DTS channel center frequency.
- b) Set span to at least 1.5 times the OBW.
- c) Set RBW to: $3 \text{ kHz} \leq \text{RBW} \leq 100 \text{ kHz}$.
- d) Set VBW $\geq 3 \times \text{RBW}$.
- e) Detector = power averaging (RMS) or sample detector (when RMS not available).
- f) Ensure that the number of measurement points in the sweep $\geq 2 \times \text{span}/\text{RBW}$.
- g) Sweep time = auto couple.
- h) Employ trace averaging (RMS) mode over a minimum of 100 traces.
- j) If measured value exceeds limit, reduce RBW (no less than 3 kHz) and repeat (note that this may require zooming in on the emission of interest and reducing the span in order to meet the minimum measurement point requirement as the RBW is reduced).

10.3 Test Setup Layout

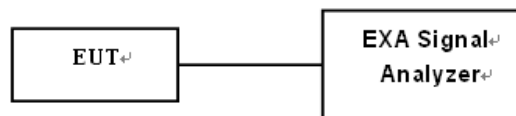



10.4 Test Result and Data

Test Date: Jul. 22, 2017

Temperature: 24°C

Atmospheric pressure: 1014 hPa

Humidity: 47%

Modulation Type	Frequency (MHz)	Power Spectral Density (dBm)
IEEE 802.11b	2412	-3.859
	2437	-2.839
	2462	-1.371
IEEE 802.11g	2412	-5.971
	2437	-5.920
	2462	-6.762
IEEE 802.11n HT20	2412	-6.276
	2437	-5.534
	2462	-5.493



Modulation Standard: 802.11b
Channel: 01

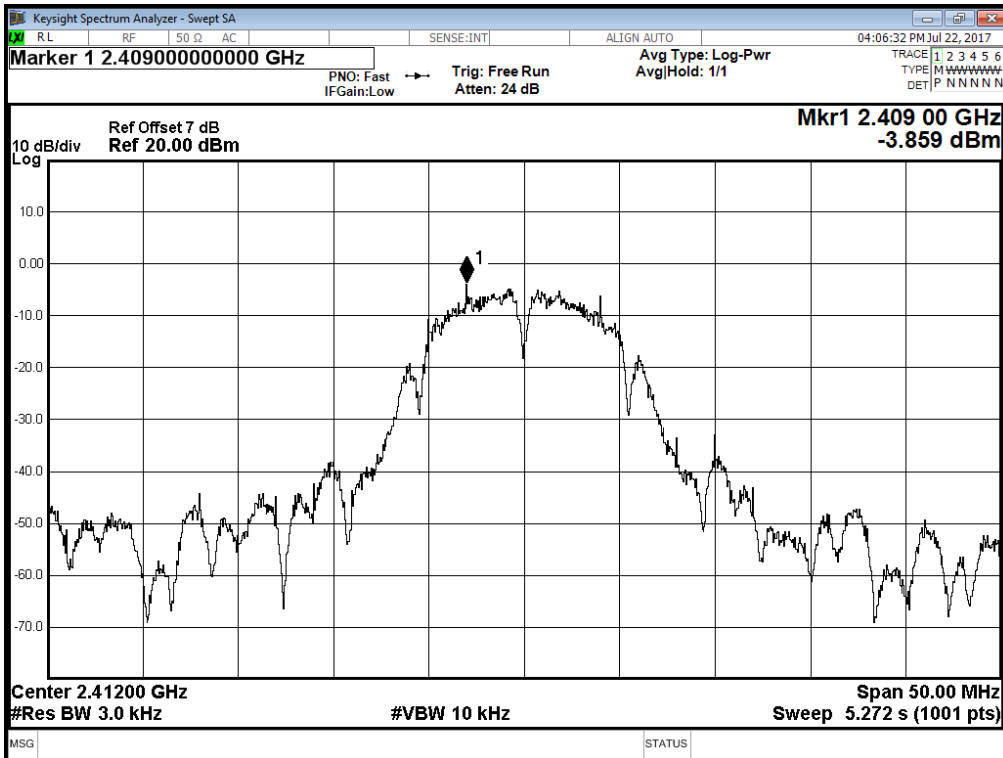

Modulation Standard: 802.11b
Channel: 06

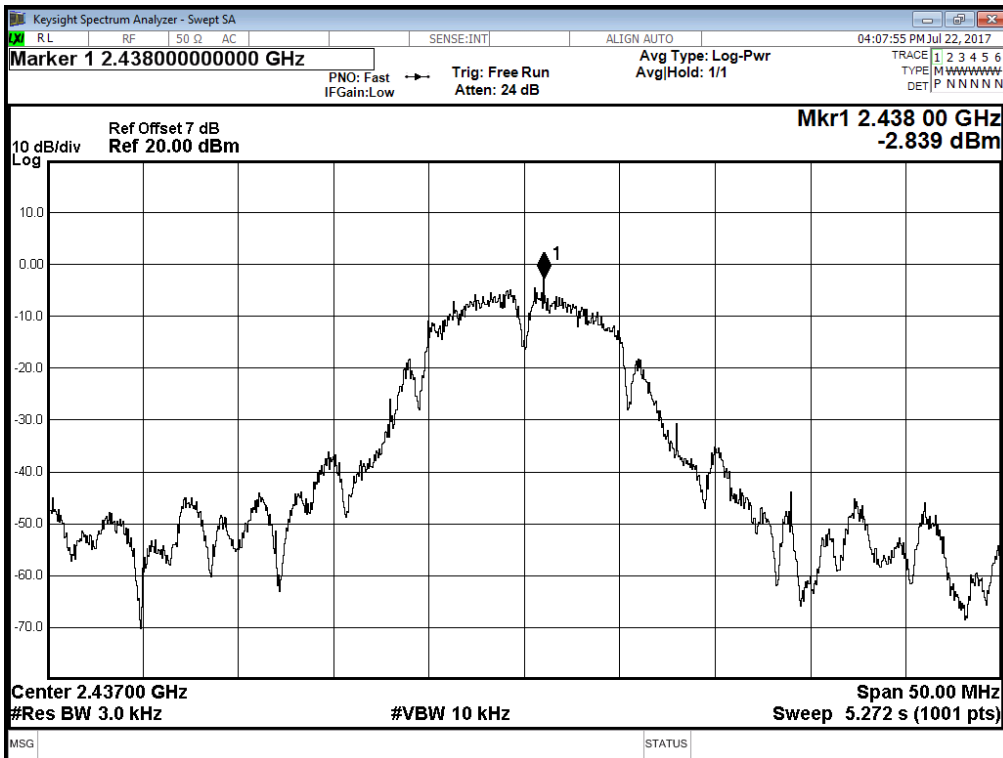



Modulation Standard: 802.11b
Channel: 11

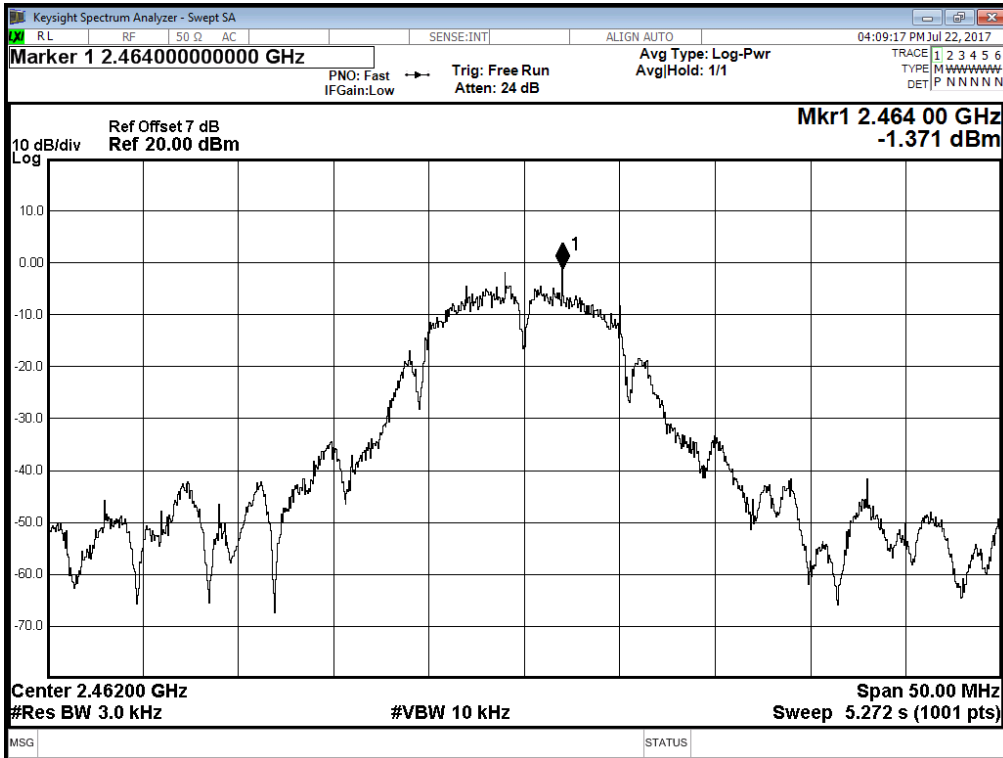

Modulation Standard: 802.11g
Channel: 01

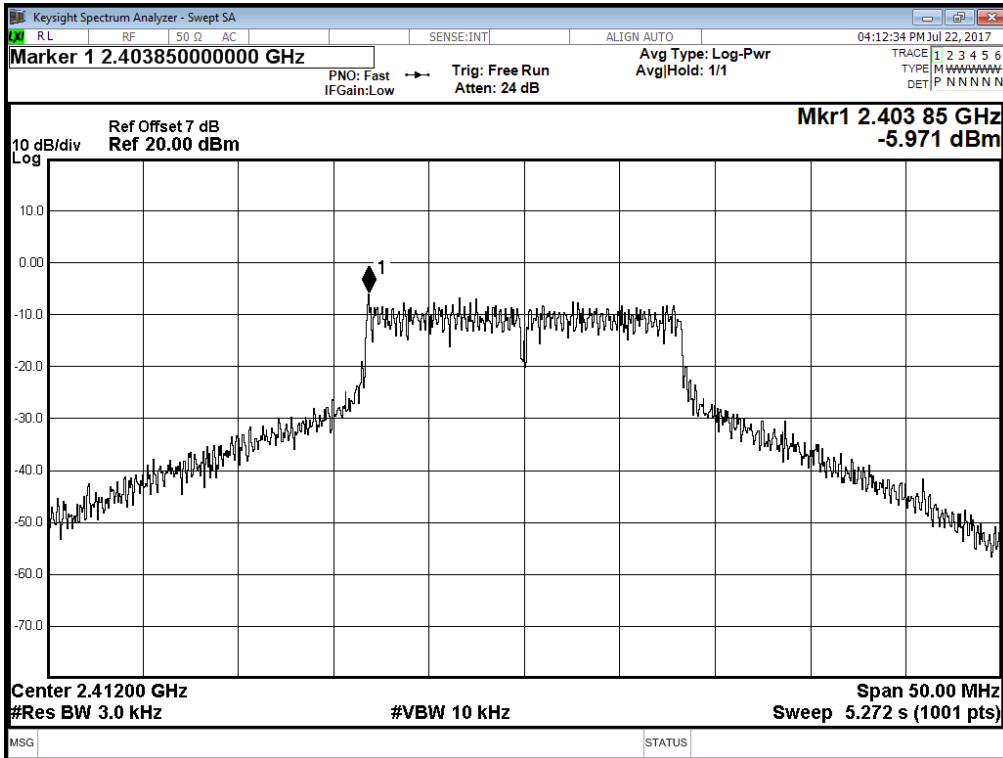



Modulation Standard: 802.11g
Channel: 06

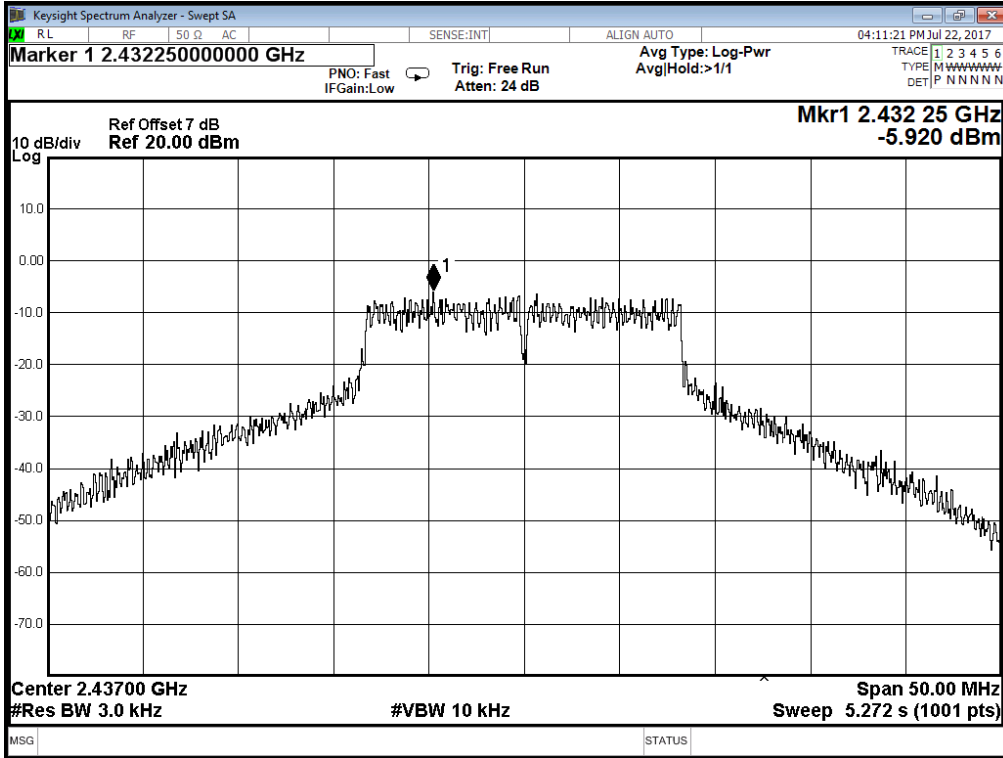

Modulation Standard: 802.11g
Channel: 11

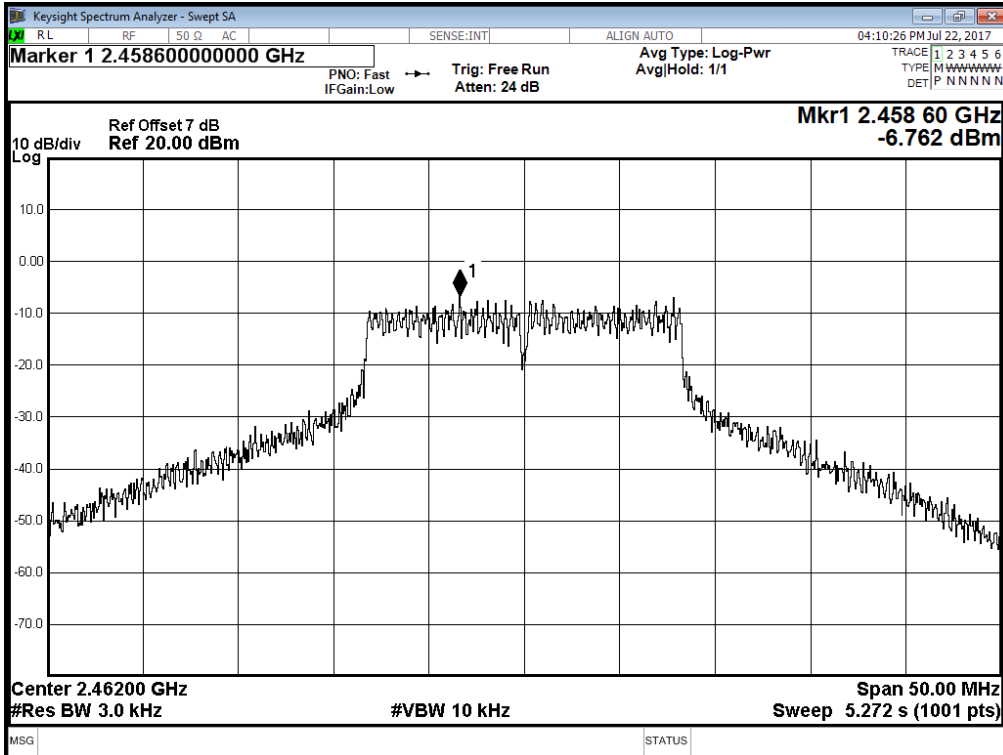



Modulation Standard: 802.11n HT20
Channel: 01

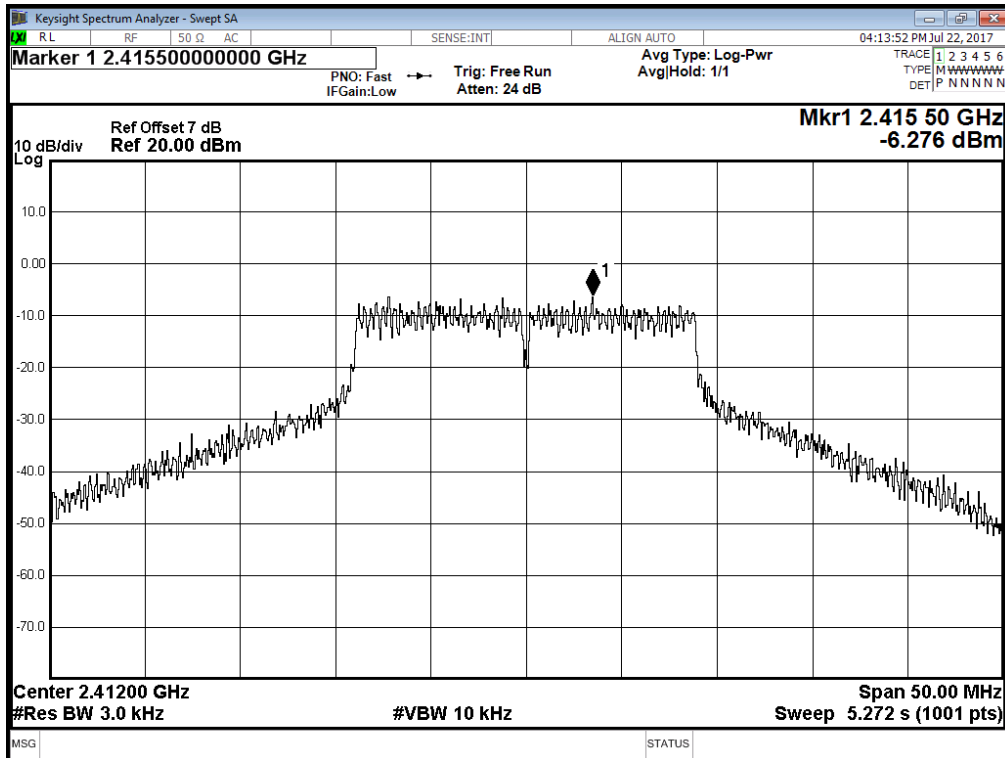

Modulation Standard: 802.11n HT20
Channel: 06

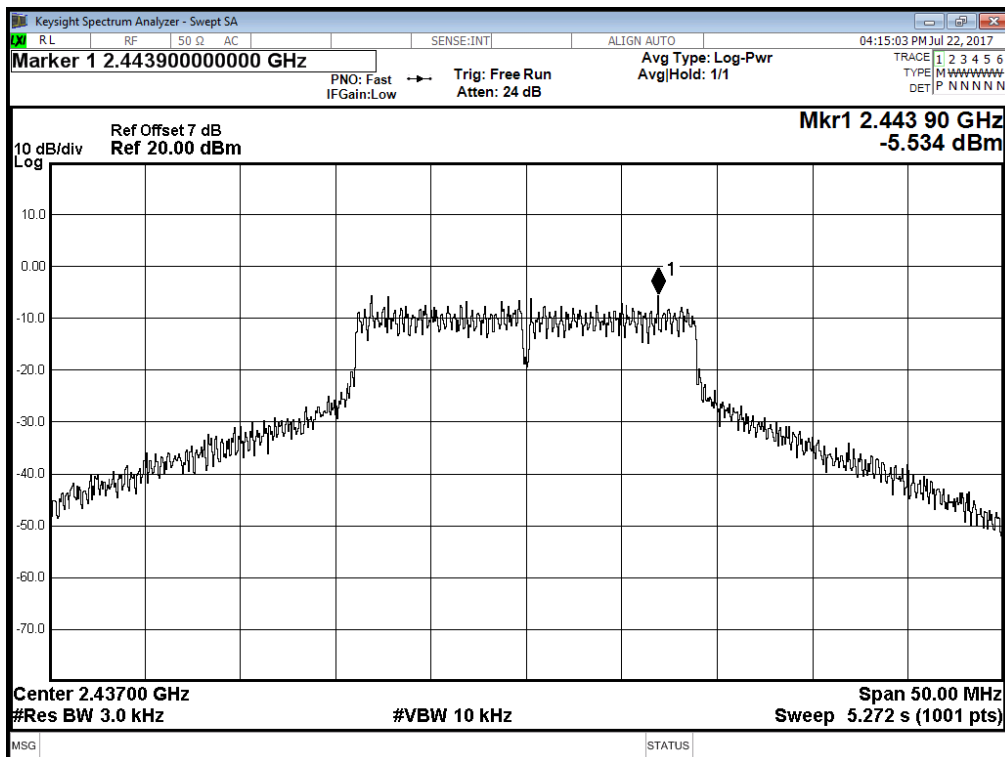



Modulation Standard: 802.11n HT20
Channel: 11

