



AquaMutant

WiFi IEEE802.11 b/g/n module
無線網路模組

AQM100-WM

User Manual & 使用手冊

Federal Communication Commission Interference Statement

This equipment has been tested and found to comply with the limits for a Class B digital device, pursuant to Part 15 of the FCC Rules. These limits are designed to provide reasonable protection against harmful interference in a residential installation. This equipment generates, uses, and can radiate radio frequency energy and, if not installed and used in accordance with the instructions, may cause harmful interference to radio communications. However, there is no guarantee that interference will not occur in a particular installation. If this equipment does cause harmful interference to radio or television reception, which can be determined by turning the equipment off and on, the user is encouraged to try to correct the interference by one or more of the following measures:

- Reorient or relocate the receiving antenna.
- Increase the separation between the equipment and receiver.
- Connect the equipment into an outlet on a circuit different from that to which the receiver is connected.
- Consult the dealer or an experienced radio/TV technician for help.

FCC Caution:

This device complies with Part 15 of the FCC Rules. Operation is subject to the following two conditions: (1) This device may not cause harmful interference, and (2) this device must accept any interference received, including interference that may cause undesired operation.

FCC Radiation Exposure Statement:

This equipment complies with FCC radiation exposure limits set forth for an uncontrolled environment. This equipment should be installed and operated with minimum distance 20cm between the radiator & your body.

End product labeling:

This transmitter module is authorized only for use in device where the antenna may be installed such that 20 cm may be maintained between the antenna and users. The final end product must be labeled in a visible area with the following: "Contains FCC ID: 2AM3NAQM100PS4RT001".

Validity of using the module certification:

In the event that these conditions cannot be met (for example certain laptop configurations or co-location with another transmitter), then the FCC authorization for this module in combination with the host equipment is no longer considered valid and the FCC ID of the module cannot be used on the final product. In these circumstances, the OEM integrator will be responsible for re-evaluating the end product (including the transmitter) and obtaining a separate FCC authorization.

Custom design antennas may be used, however the OEM installer must following the FCC 15.21 requirements and verify if new FCC approval will be necessary.

Information that must be placed in the end user manual:

The OEM integrator has to be aware not to provide information to the end user regarding how to install or remove this RF module in the user's manual of the end product which integrates this module. The end user manual shall include all required regulatory information/warning as show in this manual.

Co-location warning:

This transmitter must not be co-located or operating in conjunction with any other antenna or transmitter.

OEM integration instructions:

This device is intended only for OEM integrators under the following conditions:

The antenna must be installed such that 20 cm is maintained between the antenna and users, and the transmitter module may not be co-located with any other transmitter or antenna. The module shall be only used with the external antenna(s) that has been originally tested and certified with this module.

For all products market in US, OEM has to limit the operation channels in Channel 1 to Channel 11 or 3-9 as specified above by the supplied firmware programming tool. OEM shall not supply any tool or info to the end-user regarding to Regulatory Domain change.

As long as 3 conditions above are met, further transmitter test will not be required. However, the OEM integrator is still responsible for testing their end-product for any additional compliance requirements required with this module installed (for example, digital device emissions, PC peripheral requirements, etc.).

Important Notes:

The OEM integrator has to be aware not to provide information to the end user regarding how to install or remove this RF module in the user's manual of the end product which integrates this module. The end user manual shall include all required regulatory information/warning as show in this manual.

This device complies with Industry Canada licence-exempt RSS standard(s).

Operation is subject to the following two conditions:

- (1) This device may not cause interference, and
- (2) This device must accept any interference, including interference that may cause undesired operation of the device.

Le présent appareil est conforme aux CNR d'Industrie Canada applicables aux appareils radio exempts de licence.

L'exploitation est autorisée aux deux conditions suivantes:

- (1) l'appareil ne doit pas produire de brouillage, et
- (2) l'utilisateur de l'appareil doit accepter tout brouillage radioélectrique subi, même si le brouillage est susceptible d'en compromettre le fonctionnement.

IC Radiation Exposure Statement

This equipment complies with IC RSS-102 radiation exposure limit set forth for an uncontrolled environment. This equipment should be installed and operated with minimum distance 20cm between the radiator and your body.

Déclaration d'exposition à la radiation : Cet équipement respecte les limites d'exposition aux rayonnements IC définies pour un environnement non contrôlé. Cet équipement doit être installé et mis en marche à une distance minimale de 20 cm qui sépare l'élément rayonnant de votre corps. L'émetteur ne doit ni être utilisé avec une autre antenne ou un autre émetteur ni se trouver à leur proximité.

The final end product must be labeled in a visible area with the following: Contains IC: 23049-AQM100WM

Plaque signalétique du produit final

Le produit final doit être étiqueté dans un endroit visible avec l'inscription suivante: Contient des IC: 23049-AQM100WM.

一般設備(低功率電波輻射性電機管理辦法第 12、14 條)

--- 經型式認證合格之低功率射頻電機，非經許可，公司、商號或使用者均不得擅自變更頻率，加大功率或變更原設計之特性及功能。

--- 低功率射頻電機之使用不得影響飛航安全及干擾合法通信：經發現有干擾現象時，應立即停用，並改善至無干擾時方得繼續使用。

前項合法通信，指依電信法規定作業之無線電通信低功率射頻電機需忍受合法通信或工業、科學及醫療用電波輻射性電機設備之干擾。

本模組於取得認證後將依規定於模組本體標示審驗合格標籤，並要求最終產品平台廠商(OEM Integrator)於最終產品平台(End Product)上標示“本產品內含射頻模組，其 NCC 型式認證號碼為： CCXxxYYyyZzW”

1. 無線網路模組

WiFi IEEE802.11 b/g/n module



2. 工作原理

AQM100-WM 無線網路模組 是低功耗高性價比的嵌入式無線網路控制模塊。可滿足智能電網、樓宇自動化、安防、智能家居、遠程醫療等物聯網應用的需求。

該模塊核心處理器 ESP8266 在較小尺寸封裝中集成了業界領先的 Tensilica L106 超低功耗 32 位微型 MCU，帶有 16 位精簡模式，主頻持 80 MHz 和 160 MHz，支持 RTOS，集成 Wi-Fi MAC/ BB/RF/PA/LNA，板載天線。

該模塊支持標準的 IEEE802.11 b/g/n 協議，完整的 TCP/IP 協議棧。用戶可以使用該模塊為現有的設備添加聯網功能，也可以構建獨立的網絡控制器

主要特性

工作電壓：3.3V

工作環境溫度：-40 - 85°C

CPU Tensilica L106

- o RAM 50KB (可用)
- o Flash 16Mbit 系統
- o 802.11 b/g/n
- o 內置 Tensilica L106 超低功耗 32 位微型 MCU，帶有 16 位精簡模式，主頻支持 80 MHz 和 160 MHz，支持 RTOS
- o WIFI @2.4 GHz，支持 WPA/WPA2 安全模式
- o 超小尺寸模組 18.6mm*15.0mm
- o 內置 10 bit 高精度 ADC
- o 內置 TCP/IP 協議棧
- o 內置 TR 開關、 balun、 LNA、功率放大器和匹配網絡
- o 內置 PLL、穩壓器和電源管理組件 802.11b 模式下+ 20 dBm 的輸出功率
- o 支持天線分集
- o 深度睡眠保持電流為 20uA，關斷電流小於 5uA

- 可以兼作應用處理器 SDIO 2.0、 SPI、 UART
- STBC、 A-MPDU 、 A-MSDU 的聚合和 0.4 s 的保護間隔
- 2ms 之內喚醒、連接並傳遞數據包
- 待機狀態消耗功率小於 1.0mW (DTIM3)
- 支持 AT 遠程升級及雲端 OTA 升級
- 支持 STA/AP/STA+AP 工作模式

Operating Brief

AQM100-WM wireless network module is a low-cost, cost-effective embedded wireless network control module. Can meet the smart grid, building automation, security, smart home, telemedicine and other Internet applications needs

The core processor of the module, the ESP8266, integrates the industry-leading Tensilica L106 ultra low power 32-bit micro MCU in a smaller package with 16-bit lean mode with 80 MHz and 160 MHz, RTOS support, WiFi MAC / BB / RF / PA / LNA, onboard antenna.

The module supports the standard IEEE802.11 b / g / n protocol, the complete TCP / IP protocol stack. Users can use the module to add networking to existing devices, or to build a separate network controller

Key Features

Operating voltage: 3.3V

Operating temperature: -40 - 85 ° C

CPU Tensilica L106

0 RAM 50KB (available)

0 Flash 16Mbit System

0 802.11 b / g / n

0 Built-in Tensilica L106 ultra low power 32-bit micro MCU, with 16-bit streamlined mode, clocked at 80 MHz and 160 MHz support RTOS

0 WIFI @ 2.4 GHz, support WPA / WPA2 security mode

0 Ultra-small size module 18.6mm * 15.0mm

0 Built-in 10 bit high precision ADC

0 Built-in TCP / IP protocol stack

0 Built-in TR switch, balun, LNA, power amplifier and matching network

0 Built-in PLL, regulator and power management components in 802.11b mode + 20 dBm output power

0 Supports antenna diversity

0 The deep sleep hold current is 20uA and the shutdown current is less than 5uA

0 can be doubled as application processor SDIO 2.0, SPI, UART

0 STBC, A-MPDU, A-MSDU aggregation and 0.4 s protection interval
Within 2ms wake up, connect and pass the packet

- 0 standby power consumption less than 1.0mW (DTIM3)
- 0 support AT remote upgrade and cloud OTA upgrade
- 0 Supports STA / AP / STA + AP operation mode

4. 線路圖 schematic

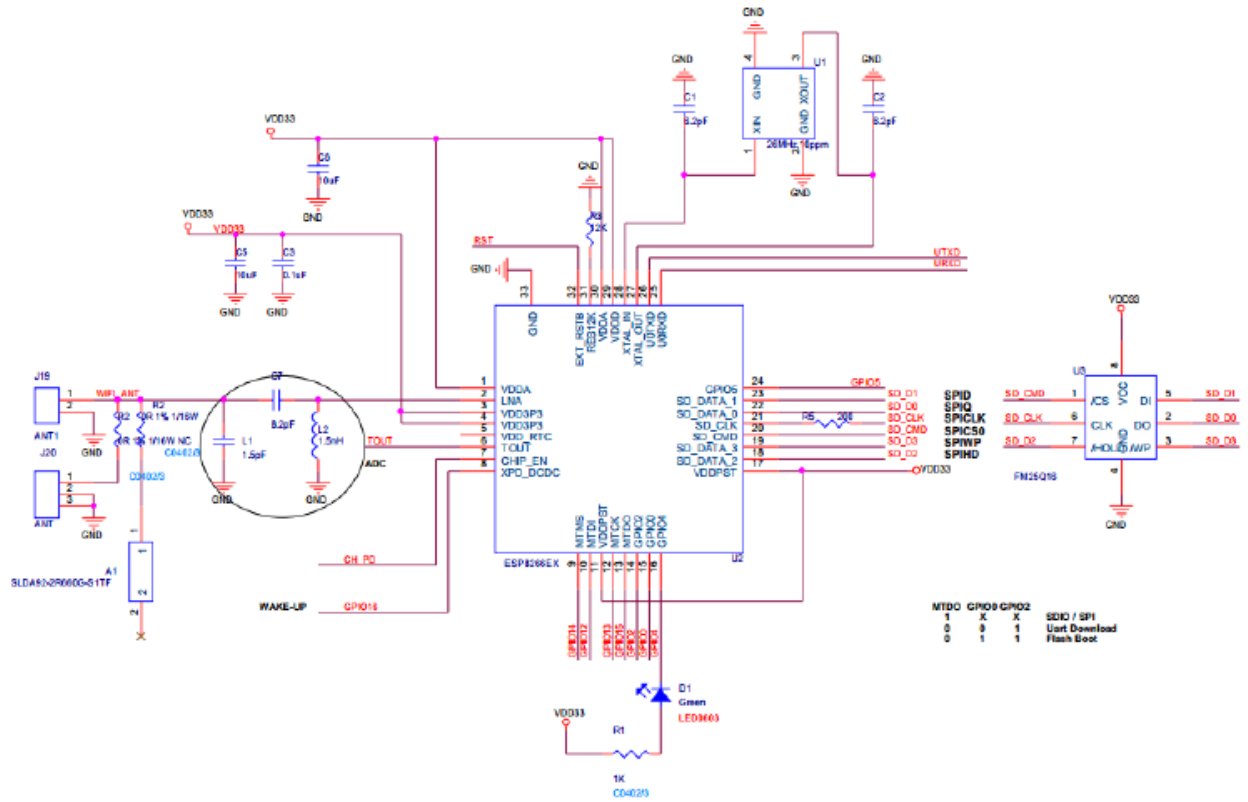

5. 安裝機構尺寸 setup mechanical dimension

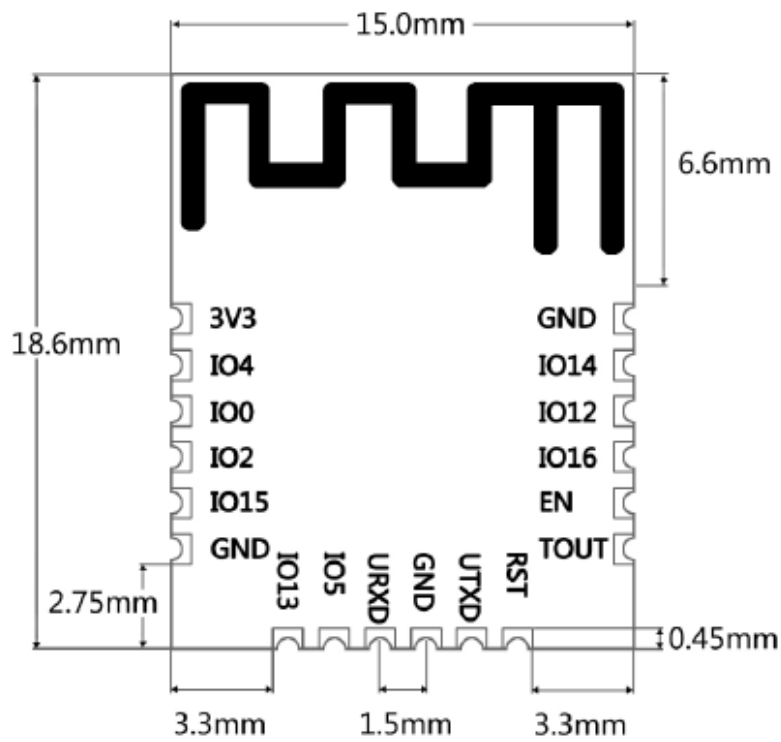

图-5 模块尺寸 (侧视图)

