

TEST REPORT

Product Name : Mifare reader w. Keypad RS485/W3
Model Number : ARD-AYBS6260,ARD-AYBS6280,ARD-AYBS6360,
ARD-AYBS6380
FCC ID : 2ALZV-AYBS6XX0

Prepared for : Bosch Security Systems BV
Address : Torenallee 49, 5617 BA Eindhoven Netherlands

Prepared by : EMTEK (SHENZHEN) CO., LTD.
Address : Building 69, Majialong Industry Zone, Nanshan District,
Shenzhen, Guangdong, China

Tel: (0755) 26954280
Fax: (0755) 26954282

Report Number : ES201019021W
Date(s) of Tests : October 19, 2020 to November 02, 2020
Date of issue : November 02, 2020

Table of Contents

| | |
|---|-----------|
| TEST REPORT | 1 |
| 1 EUT TECHNICAL DESCRIPTION | 4 |
| 2 SUMMARY OF TEST RESULT | 5 |
| 3 TEST METHODOLOGY | 6 |
| 3.1 GENERAL DESCRIPTION OF APPLIED STANDARDS..... | 6 |
| 3.2 MEASUREMENT EQUIPMENT USED..... | 6 |
| 3.3 DESCRIPTION OF TEST MODES..... | 7 |
| 4 FACILITIES AND ACCREDITATIONS | 8 |
| 4.1 FACILITIES..... | 8 |
| 4.2 LABORATORY ACCREDITATIONS AND LISTINGS..... | 8 |
| 5 TEST SYSTEM UNCERTAINTY | 9 |
| 6 SETUP OF EQUIPMENT UNDER TEST | 10 |
| 6.1 RADIO FREQUENCY TEST SETUP 1..... | 10 |
| 6.2 RADIO FREQUENCY TEST SETUP 2..... | 10 |
| 6.3 CONDUCTED EMISSION TEST SETUP..... | 11 |
| 6.4 BLOCK DIAGRAM CONFIGURATION OF TEST SYSTEM..... | 12 |
| 6.5 SUPPORT EQUIPMENT..... | 12 |
| 7 TEST REQUIREMENTS | 13 |
| 7.1 OCCUPIED BANDWIDTH..... | 13 |
| 7.2 FREQUENCY STABILITY..... | 15 |
| 7.3 RADIATED SPURIOUS EMISSION..... | 17 |
| 7.4 CONDUCTED EMISSION TEST..... | 28 |
| 8 ANTENNA APPLICATION | 29 |
| 8.1 ANTENNA REQUIREMENT..... | 29 |
| 8.2 RESULT..... | 29 |

TEST RESULT CERTIFICATION

Applicant : Bosch Security Systems BV
Address : Torenallee 49, 5617 BA Eindhoven Netherlands
Manufacturer : Bosch Security Systems BV
Address : Torenallee 49, 5617 BA Eindhoven Netherlands
EUT : Mifare reader w. Keypad RS485/W3
Model Name : ARD-AYBS6260,ARD-AYBS6280,ARD-AYBS6360,ARD-AYBS6380
Trademark : Rosslare

Measurement Procedure Used:

| APPLICABLE STANDARDS | |
|---|-------------|
| STANDARD | TEST RESULT |
| FCC 47 CFR Part 2, Subpart J FCC 47 CFR Part 15, Subpart C | PASS |

The above equipment was tested by EMTEK(SHENZHEN) CO., LTD. The test data, data evaluation, test procedures, and equipment configurations shown in this report were made in accordance with the procedures given in ANSI C63.10 (2013) and the energy emitted by the sample EUT tested as described in this report is in compliance with the requirements of FCC Rules Part 2 and Part 15.225.

The test results of this report relate only to the tested sample identified in this report.

Date of Test : October 19, 2020 to November 02, 2020

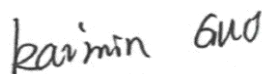
Prepared by : 
Kaimin Guo /Editor

Reviewer : 
Jessie Hu /Supervisor

Approved & Authorized Signer : 
Lisa Wang /Manager



1 EUT TECHNICAL DESCRIPTION

| Characteristics | Description |
|---------------------|---|
| Device Type: | RFID |
| Modulation: | ASK modulation |
| Channel Frequency: | 13.56MHz |
| Number of Channels: | 1 channel |
| Antenna Type : | Coil Antenna |
| Power supply: | <input checked="" type="checkbox"/> DC 12V by Battery |
| Temperature Range | -20°C ~ +50°C |

Note: for more details, please refer to the User's manual of the EUT.

2 SUMMARY OF TEST RESULT

| FCC Part Clause | Test Parameter | Verdict | Remark |
|-----------------------------|-----------------------------|---------|--------|
| 2.1049 | Occupied Bandwidth | PASS | |
| 15.225(e) | Frequency stability | PASS | |
| 15.225(d) 15.209 | Radiated Spurious Emissions | PASS | |
| 15.207 | Conducted Emission | N/A | |
| NOTE1: N/A (Not Applicable) | | | |

RELATED SUBMITTAL(S) / GRANT(S):

This submittal(s) (test report) is intended for FCC ID: 2ALZV-AYBS6XX0 filing to comply with Section 15.225 of the FCC Part 15, Subpart C Rules.



3 TEST METHODOLOGY

3.1 GENERAL DESCRIPTION OF APPLIED STANDARDS

According to its specifications, the EUT must comply with the requirements of the following standards:
 FCC 47 CFR Part 2, Subpart J
 FCC 47 CFR Part 15, Subpart C

3.2 MEASUREMENT EQUIPMENT USED

3.2.1 Conducted Emission Test Equipment

| EQUIPMENT TYPE | MFR | MODEL NUMBER | SERIAL NUMBER | LAST CAL. | Due. CAL |
|--------------------|-----------------|--------------|---------------|------------|------------|
| Test Receiver | Rohde & Schwarz | ESCS30 | 828985/018 | 05/22/2020 | 05/21/2021 |
| L.I.S.N. | Schwarzbeck | NNLK8129 | 8129203 | 05/22/2020 | 05/21/2021 |
| 50Ω Coaxial Switch | Anritsu | MP59B | M20531 | N/A | N/A |

3.2.2 Radiated Emission Test Equipment

| EQUIPMENT TYPE | MFR | MODEL NUMBER | SERIAL NUMBER | LAST CAL. | Due. CAL |
|-------------------|-----------------|--------------|---------------|------------|------------|
| EMI Test Receiver | Rohde & Schwarz | ESU | 1302.6005.26 | 05/22/2020 | 05/21/2021 |
| Pre-Amplifier | HP | 8447D | 2944A07999 | 05/22/2020 | 05/21/2021 |
| Bilog Antenna | Schwarzbeck | VULB9163 | 142 | 05/22/2020 | 05/21/2021 |
| Loop Antenna | ARA | PLA-1030/B | 1029 | 05/22/2020 | 05/21/2021 |
| Cable | Schwarzbeck | AK9513 | ACRX1 | 05/22/2020 | 05/21/2021 |
| Cable | Rosenberger | N/A | FP2RX2 | 05/22/2020 | 05/21/2021 |
| Cable | Schwarzbeck | AK9513 | CRPX1 | 05/22/2020 | 05/21/2021 |
| Cable | Schwarzbeck | AK9513 | CRRX2 | 05/22/2020 | 05/21/2021 |

3.2.3 Radio Frequency Test Equipment

| EQUIPMENT TYPE | MFR | MODEL NUMBER | SERIAL NUMBER | LAST CAL. | Due. CAL |
|-------------------|---------|--------------|---------------|------------|------------|
| Spectrum Analyzer | Agilent | E4407B | 88156318 | 05/22/2020 | 05/21/2021 |
| Signal Analyzer | Agilent | N9010A | My53470879 | 05/22/2020 | 05/21/2021 |
| Power meter | Anritsu | ML2495A | 0824006 | 05/22/2020 | 05/21/2021 |
| Power sensor | Anritsu | MA2411B | 0738172 | 05/22/2020 | 05/21/2021 |

Remark: Each piece of equipment is scheduled for calibration once a year.

3.3 DESCRIPTION OF TEST MODES

The EUT has been tested under its typical operating condition.

The EUT configuration for testing is installed on RF field strength measurement to meet the Commissions requirement and operating in a manner which intends to maximize its emission characteristics in a continuous normal application.

The Transmitter was operated in the normal operating mode. The TX frequency was fixed which was for the purpose of the measurements.

Pre-defined engineering program for regulatory testing used to control the EUT for staying in continuous transmitting mode is programmed.



4 FACILITIES AND ACCREDITATIONS

4.1 FACILITIES

All measurement facilities used to collect the measurement data are located at

Bldg 69, Majialong Industry Zone District, Nanshan District, Shenzhen, China

The sites are constructed in conformance with the requirements of ANSI C63.7, ANSI C63.10 and CISPR Publication 22.

4.2 LABORATORY ACCREDITATIONS AND LISTINGS

Site Description

EMC Lab. : AAccredited by CNAS, 2018.11.30
The certificate is valid until 2022.10.28
The Laboratory has been assessed and proved to be in compliance with CNAS-CL01 (identical to ISO/IEC 17025:2017)
The Certificate Registration Number is L2291

Designation Number: CN1204
Test Firm Registration Number: 882943
Accredited by A2LA, August 31, 2020
The Certificate Registration Number is 4321.01.

Accredited by Industry Canada, November 09, 2018
The Conformity Assessment Body Identifier is CN0008.

Name of Firm : EMTEK(SHENZHEN) CO., LTD.
Site Location : Bldg 69, Majialong Industry Zone, Nanshan District, Shenzhen, Guangdong, China

5 TEST SYSTEM UNCERTAINTY

The following measurement uncertainty levels have been estimated for tests performed on the apparatus:

| Parameter | Uncertainty |
|--------------------------|-------------------------|
| Radio Frequency | $\pm 1 \times 10^{-5}$ |
| Conducted Emissions Test | $\pm 2.0\text{dB}$ |
| Radiated Emission Test | $\pm 2.0\text{dB}$ |
| Occupied Bandwidth Test | $\pm 1.0\text{dB}$ |
| All emission, radiated | $\pm 3\text{dB}$ |
| Temperature | $\pm 0.5^\circ\text{C}$ |
| Humidity | $\pm 3\%$ |

Measurement Uncertainty for a level of Confidence of 95%



6 SETUP OF EQUIPMENT UNDER TEST

6.1 RADIO FREQUENCY TEST SETUP 1

The component's antenna ports(s) of the EUT are connected to the measurement instrument per an appropriate attenuator. The EUT is controlled by PC/software to emit the specified signals for the purpose of measurements.

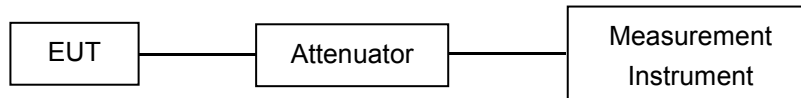

6.2 RADIO FREQUENCY TEST SETUP 2

The test site semi-anechoic chamber has met the requirement of NSA tolerance 4 dB according to the standards: ANSI C63.10. The test distance is 3m. The setup is according to the requirements in Section 13.1.4.1 of ANSI C63.10-2013 and CAN/CSA-CEI/IEC CISPR 22.

Below 30MHz:

The EUT is placed on a turntable 0.8 meters above the ground in the chamber, 3 meter away from the antenna (loop antenna). The Antenna should be positioned with its plane vertical at the specified distance from the EUT and rotated about its vertical axis for maximum response at each azimuth about the EUT. The center of the loop shall be 1 m above the ground. For certain applications, the loop antenna plane may also need to be positioned horizontally at the specified distance from the EUT.

Above 30MHz:

The EUT is placed on a turntable 0.8 meters above the ground in the chamber, 3 meter away from the antenna. The maximal emission value is acquired by adjusting the antenna height, polarisation and turntable azimuth. Normally, the height range of antenna is 1 m to 4 m, the azimuth range of turntable is 0° to 360°, and the receive antenna has two polarizations Vertical (V) and Horizontal (H).

(a) Radiated Emission Test Set-Up, Frequency Below 30MHz

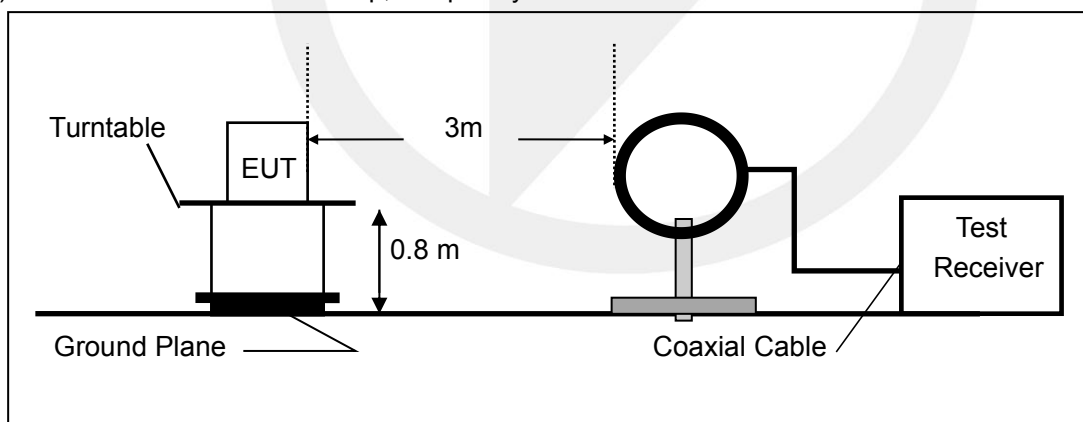

(b) Radiated Emission Test Set-Up, Frequency Below 1000MHz

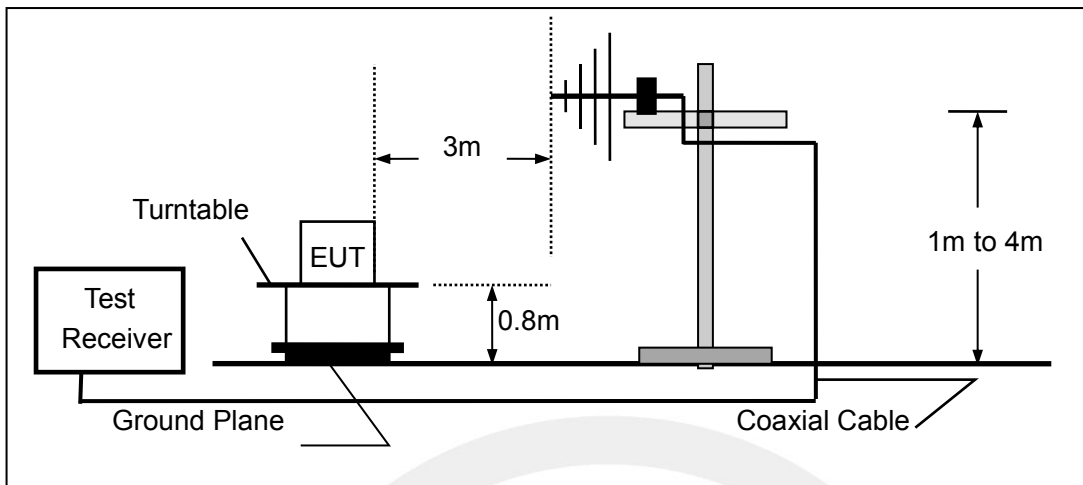

6.3 CONDUCTED EMISSION TEST SETUP

The mains cable of the EUT (maybe per AC/DC Adapter) must be connected to LISN. The LISN shall be placed 0.8 m from the boundary of EUT and bonded to a ground reference plane for LISN mounted on top of the ground reference plane. This distance is between the closest points of the LISN and the EUT. All other units of the EUT and associated equipment shall be at least 0.8m from the LISN.

Ground connections, where required for safety purposes, shall be connected to the reference ground point of the LISN and, where not otherwise provided or specified by the manufacturer, shall be of same length as the mains cable and run parallel to the mains connection at a separation distance of not more than 0.1 m.

According to the requirements in ANSI C63.10-2013 Conducted emissions from the EUT measured in the frequency range between 0.15 MHz and 30 MHz using CISPR Quasi-Peak and average detector mode.

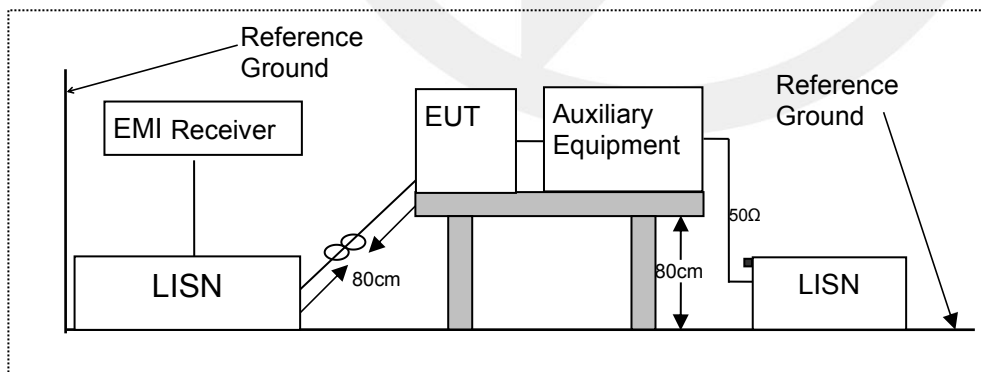

6.4 BLOCK DIAGRAM CONFIGURATION OF TEST SYSTEM

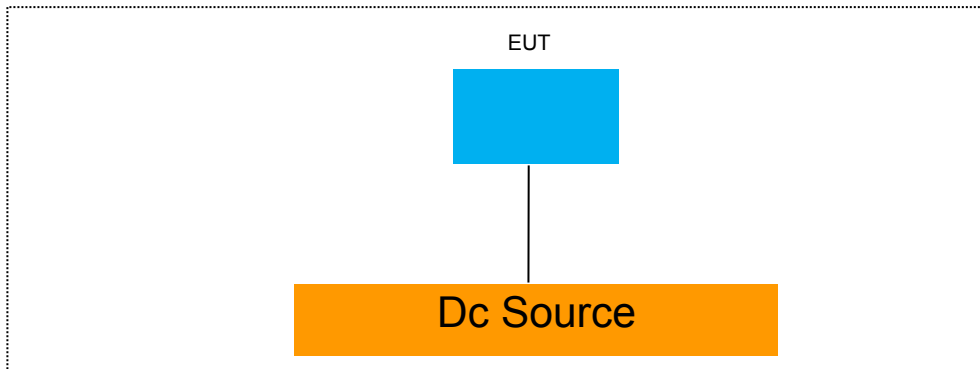

6.5 SUPPORT EQUIPMENT

| EUT Cable List and Details | | | |
|----------------------------|------------|---------------------|------------------------|
| Cable Description | Length (m) | Shielded/Unshielded | With / Without Ferrite |
| DC cable | 1.2 | Unshielded | With Ferrite |

| Auxiliary Cable List and Details | | | |
|----------------------------------|------------|---------------------|------------------------|
| Cable Description | Length (m) | Shielded/Unshielded | With / Without Ferrite |
| / | / | / | / |

| Auxiliary Equipment List and Details | | | |
|--------------------------------------|--------------|-------|---------------|
| Description | Manufacturer | Model | Serial Number |
| / | / | / | / |

Notes:

1. All the equipment/cables were placed in the worst-case configuration to maximize the emission during the test.
2. Grounding was established in accordance with the manufacturer's requirements and conditions for the intended use.
3. Unless otherwise denoted as EUT in [Remark] column, device(s) used in tested system is a support equipment

7 TEST REQUIREMENTS

7.1 OCCUPIED BANDWIDTH

7.1.1 Applicable Standard

According to FCC Part 2.1049

7.1.2 Conformance Limit

Intentional radiators operating under the alternative provisions to the general emission limits, as contained in part 15.217 through 15.257 and in subpart E of this part, must be designed to ensure that the 20 dB bandwidth of the emission, or whatever bandwidth may otherwise be specified in the specific rule section under which the equipment operates, is contained within the frequency band designated in the rule section under which the equipment is operated.

7.1.3 Test Configuration

Test according to clause 6.1 radio frequency test setup 1

7.1.4 Test Procedure

The EUT was operating in transmit mode and controlled its channel. Printed out the test result from the spectrum by hard copy function.

The RF output of EUT was connected to the spectrum analyzer by RF cable and attenuator. The path loss was compensated to the results for each measurement.

Set to the maximum power setting and enable the EUT transmit continuously

Set RBW = 1% occupied bandwidth.

Set the video bandwidth (VBW) =3 times RBW .

Set Span= approximately 2 to 3 times the occupied bandwidth

Set Detector = Peak.

Set Trace mode = max hold.

Set Sweep = auto couple.

The EUT should be transmitting at its maximum data rate. Allow the trace to stabilize. Use the marker-to-peak function to set the marker to the peak of the emission. Use the marker-delta function to measure 99% down one side of the emission. Reset the markerdelta function, and move the marker to the other side of the emission, until it is (as close as possible to) even with the reference marker level. The marker-delta reading at this point is the 99% bandwidth of the emission.

If this value varies with different modes of operation (e.g., data rate, modulation format, etc.), repeat this test for each variation.

Measure and record the results in the test report.

7.1.5 Test Results

| | | | |
|---------------|------|-------------|------|
| Temperature : | 25°C | Test Date : | |
| Humidity : | 65 % | Test By: | Andy |

| Modulation Mode | Channel Number | Channel Frequency (MHz) | 20dB Bandwidth(Hz) | 99% Bandwidth(Hz) |
|-----------------|----------------|-------------------------|--------------------|-------------------|
| ASK | 0 | 13.56 | 217 | 1100 |

20dB Bandwidth:

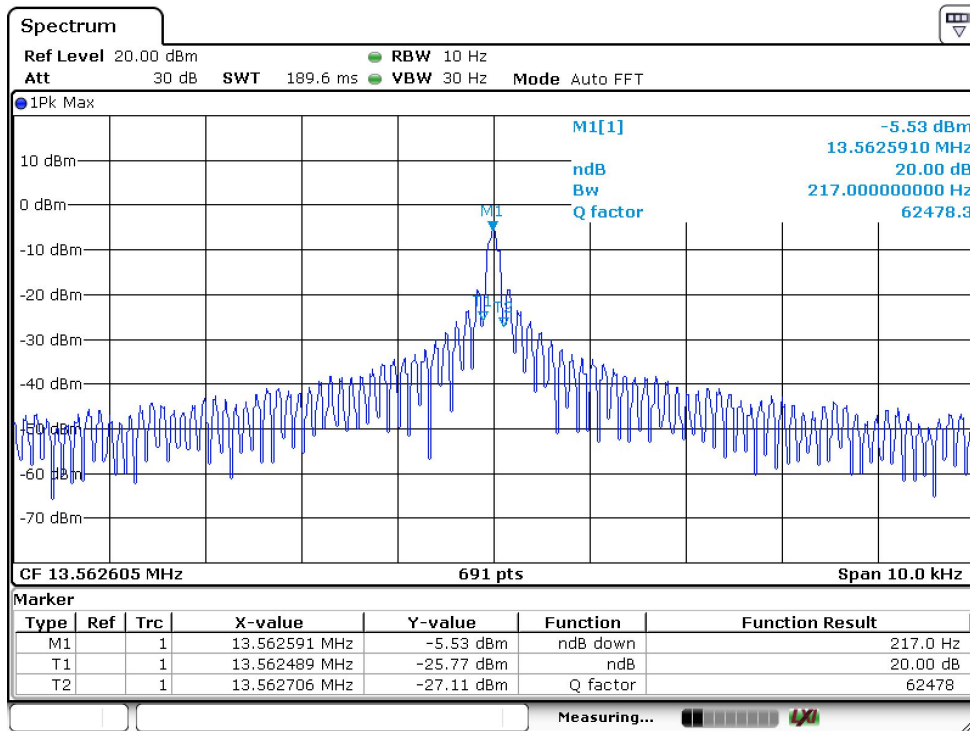

99% Bandwidth:

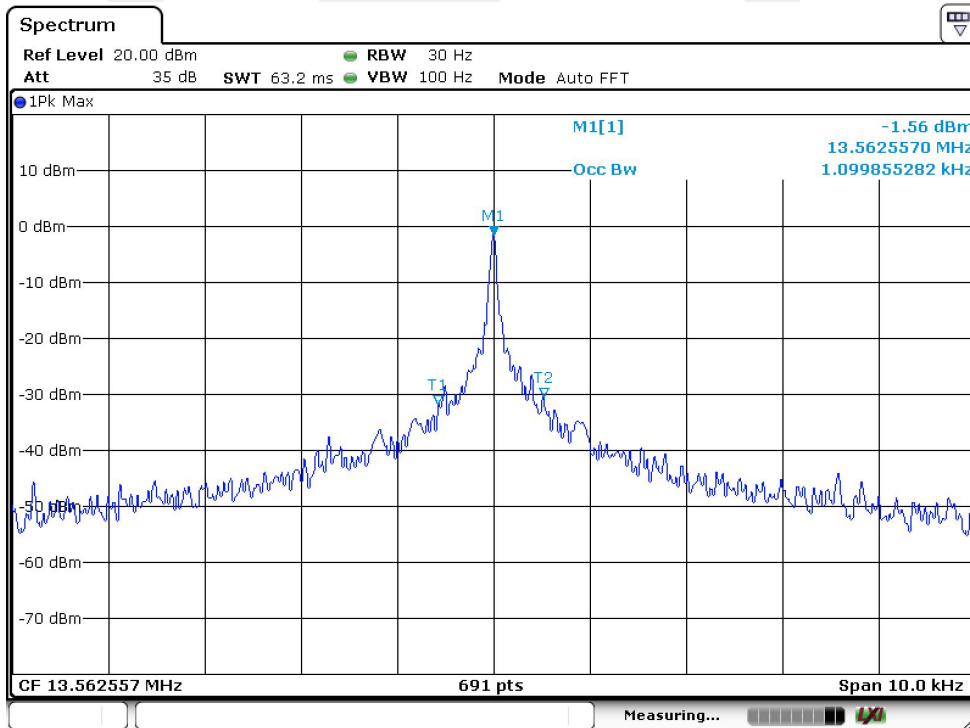

7.2 FREQUENCY STABILITY

7.2.1 Applicable Standard

According to FCC Part 2.1055

7.2.2 Conformance Limit

According to part 15.225(e), The frequency tolerance of the carrier signal shall be maintained within $\pm 0.01\%$ of the operating frequency over a temperature variation of -20 degrees to $+50$ degrees C at normal supply voltage, and for a variation in the primary supply voltage from 85% to 115% of the rated supply voltage at a temperature of 20 degrees C. For battery operated equipment, the equipment tests shall be performed using a new battery.

7.2.3 Test Configuration

Test according to clause 6.1 radio frequency test setup

7.2.4 Test Procedures

Connect the EUT to frequency analyzer via the antenna connector.

EUT was placed at temperature chamber and connected to an external power supply.

Temperature and voltage condition shall be tested to confirm frequency stability.

(a) Frequency measurements shall be made at the extremes of the specified temperature range and at intervals of not more than 10° centigrade through the range. A period of time sufficient to stabilize all of the components of the oscillator circuit at each temperature level shall be allowed prior to frequency measurement. The short-term transient effects on the frequency of the transmitter due to keying (except for broadcast transmitters) and any heating element cycling normally occurring at each ambient temperature level also shall be shown. Only the portion or portions of the transmitter containing the frequency determining and stabilizing circuitry need be subjected to the temperature variation test.

(b) The frequency stability shall be measured with variation of primary supply voltage as follows:

(1) Vary primary supply voltage from 85 to 115 percent of the nominal value for other than hand carried battery equipment.

(2) For hand carried, battery powered equipment, reduce primary supply voltage to the battery operating end point, which shall be specified by the manufacturer.

7.2.5 Test Results

| Operation Mode | Channel Number | Test Condition | | Channel Frequency (MHz) | Freq.Dev. (Hz) | Deviation (ppm) | Limit (ppm) |
|----------------|----------------|----------------|-----------|-------------------------|----------------|-----------------|-------------|
| | | Voltage (V) | Temp (°C) | | | | |
| ASK | CH0 | Vnom | -20 | 13.562557 | 2.557 | 1.885693 | 10 |
| | | | -10 | 13.562554 | 2.554 | 1.883481 | 10 |
| | | | 0 | 13.562563 | 2.563 | 1.890118 | 10 |
| | | | 10 | 13.562558 | 2.558 | 1.886431 | 10 |
| | | | 20 | 13.562552 | 2.552 | 1.882006 | 10 |
| | | | 30 | 13.562556 | 2.556 | 1.884956 | 10 |
| | | | 40 | 13.562561 | 2.557 | 1.885693 | 10 |
| | | | 50 | 13.562553 | 2.554 | 1.883481 | 10 |
| | | 85% Vnom | 20 | 13.562552 | 2.563 | 1.890118 | 10 |
| | | 115% Vnom | 20 | 13.562556 | 2.558 | 1.886431 | 10 |
| VERDICT | | | | PASS | | | |

7.3 RADIATED SPURIOUS EMISSION

7.3.1 Applicable Standard

According to FCC Part 15.225 and 15.209

7.3.2 Conformance Limit

| Field Strength of Fundamental Emissions and Spectrum Mask | | | | | |
|---|------------|--------------|--------------|--------------|-------------|
| Emissions | (uV/m)@30m | (dBuV/m)@30m | (dBuV/m)@10m | (dBuV/m)@3m | (dBuV/m)@1m |
| Fundamental | 15848 | 84.0 | 103.1 | 124.0 | 143.1 |
| Quasi peak measurement of the fundamental. | | | | | |

| Spectrum Mask | | | | | |
|-------------------------|------------|--------------|--------------|-------------|-------------|
| Freq. of Emission (MHz) | (uV/m)@30m | (dBuV/m)@30m | (dBuV/m)@10m | (dBuV/m)@3m | (dBuV/m)@1m |
| 1.705~13.110 | 30 | 29.5 | 48.6 | 69.5 | 88.6 |
| 13.110~13.410 | 106 | 40.5 | 59.6 | 80.5 | 99.6 |
| 13.410~13.553 | 334 | 50.5 | 69.6 | 90.5 | 109.6 |
| 13.553~13.567 | 15848 | 84.0 | 103.1 | 124.0 | 143.1 |
| 13.567~13.710 | 334 | 50.5 | 69.6 | 90.5 | 109.6 |
| 13.710~14.010 | 106 | 40.5 | 59.6 | 80.5 | 99.6 |
| 14.010~30.000 | 30 | 29.5 | 48.6 | 69.5 | 88.6 |

According to FCC Part 15.205, Restricted bands

| MHz | MHz | MHz | GHz |
|-------------------|---------------------|---------------|-------------|
| 0.090-0.110 | 16.42-16.423 | 399.9-410 | 4.5-5.15 |
| 10.495-0.505 | 16.69475-16.69525 | 608-614 | 5.35-5.46 |
| 2.1735-2.1905 | 16.80425-16.80475 | 960-1240 | 7.25-7.75 |
| 4.125-4.128 | 25.5-25.67 | 1300-1427 | 8.025-8.5 |
| 4.17725-4.17775 | 37.5-38.25 | 1435-1626.5 | 9.0-9.2 |
| 4.20725-4.20775 | 73-74.6 | 1645.5-1646.5 | 9.3-9.5 |
| 6.215-6.218 | 74.8-75.2 | 1660-1710 | 10.6-12.7 |
| 6.26775-6.26825 | 123-138 | 2200-2300 | 14.47-14.5 |
| 8.291-8.294 | 149.9-150.05 | 2310-2390 | 15.35-16.2 |
| 8.362-8.366 | 156.52475-156.52525 | 2483.5-2500 | 17.7-21.4 |
| 8.37625-8.38675 | 156.7-156.9 | 2690-2900 | 22.01-23.12 |
| 8.41425-8.41475 | 162.0125-167.17 | 3260-3267 | 23.6-24.0 |
| 12.29-12.293 | 167.72-173.2 | 3332-3339 | 31.2-31.8 |
| 12.51975-12.52025 | 240-285 | 3345.8-3358 | 36.43-36.5 |
| 12.57675-12.57725 | 322-335.4 | 3600-4400 | (2) |
| 13.36-13.41 | | | |

According to FCC Part15.205, the level of any transmitter spurious emission in Restricted bands shall not exceed the level of the emission specified in the following table

| Restricted Frequency(MHz) | Field Strength ($\mu\text{V}/\text{m}$) | Field Strength ($\text{dB}\mu\text{V}/\text{m}$) | Measurement Distance |
|---------------------------|---|--|----------------------|
| 0.009-0.490 | 2400/F(KHz) | 48.5 - 13.8 | 300 |
| 0.490-1.705 | 24000/F(KHz) | 33.8 - 23.0 | 30 |
| 1.705-30 | 30 | 29.5 | 30 |
| 30-88 | 100 | 40.0 | 3 |
| 88-216 | 150 | 43.5 | 3 |
| 216-960 | 200 | 46.0 | 3 |
| Above 960 | 500 | 54.0 | 3 |



7.3.3 Test Configuration

Test according to clause 6.2 radio frequency test setup 2

7.3.4 Test Procedure

This test is required for any spurious emission that falls in a Restricted Band, as defined in Section 15.205. It must be performed with the highest gain of each type of antenna proposed for use with the EUT. Use the following spectrum analyzer settings:

The EUT was placed on a turn table which is 0.8m above ground plane.

Maximum procedure was performed on the highest emissions to ensure EUT compliance.

Span = wide enough to fully capture the emission being measured

RBW = 100 kHz for $f < 1$ GHz(30MHz to 1GHz), 200Hz for $f < 150$ KHz(9KHz to 150KHz), 9KHz for $f < 30$ MHz(150KHz to 30KHz)

VBW \geq RBW

Sweep = auto

Detector function = peak

Trace = max hold

Follow the guidelines in ANSI C63.10-2013 with respect to maximizing the emission by rotating the EUT, measuring the emission while the EUT is situated in three orthogonal planes (if appropriate), adjusting the measurement antenna height and polarization, etc. A pre-amp and a high pass filter are required for this test, in order to provide the measuring system with sufficient sensitivity. Allow the trace to stabilize. The peak reading of the emission, after being corrected by the antenna factor, cable loss, pre-amp gain, etc., is the peak field strength, which must comply with the limit specified in Section 15.35(b). Submit this data.

Now set the VBW to 10 Hz, while maintaining all of the other instrument settings. This peak level, once corrected, must comply with the limit specified in Section 15.209. If the dwell time per channel of the hopping signal is less than 100 ms, then the reading obtained with the 10 Hz VBW may be further adjusted by a “duty cycle correction factor”, derived from $20\log(\text{dwell time}/100 \text{ ms})$, in an effort to demonstrate compliance with the 15.209 limit. Submit this data.

Repeat above procedures until all frequency measured was complete.

7.3.5 Test Results

■ Field Strength of Fundamental Emissions and Spectrum Mask

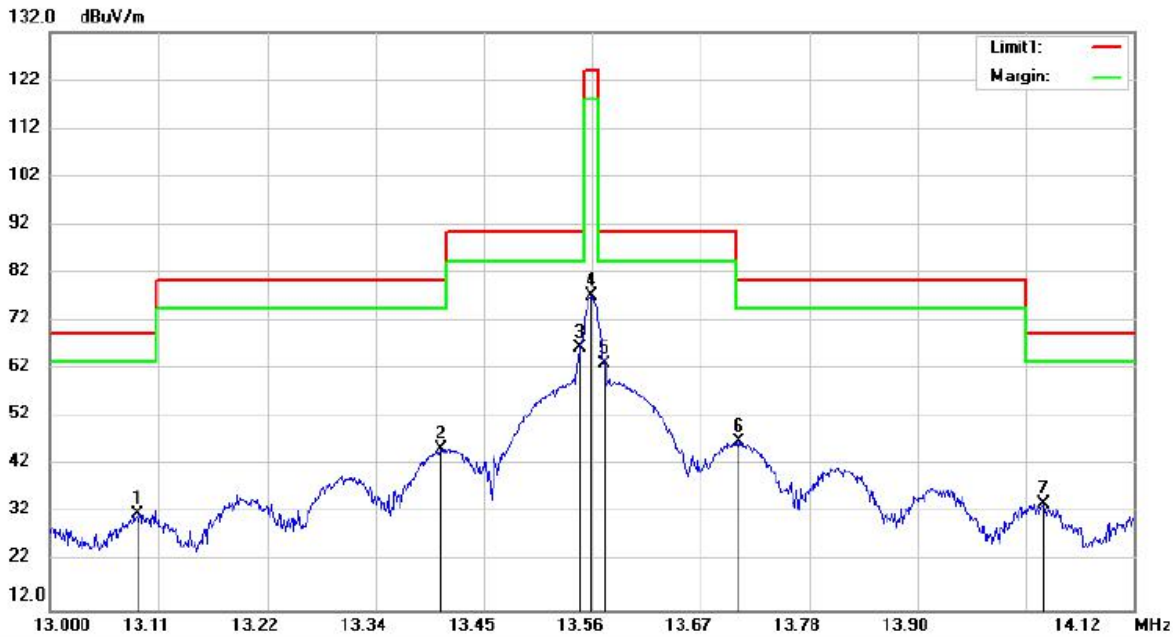

Site 3m Chamber #1 Polarization: X Temperature: 27 C
 Limit: (RE)FCC PART 15.225(Mask) Power: AC 120V/60Hz Humidity: 43 %
 Mode: TX
 Note:

| No. | Mk. | Freq. | Reading Level | Correct Factor | Measurement | Limit | Over | Antenna Height | Table Degree | |
|-----|-----|---------|---------------|----------------|-------------|--------|--------|----------------|--------------|---------|
| | | MHz | dBuV | dB | dBuV/m | dBuV/m | dB | cm | degree | Comment |
| 1 | | 13.0914 | 42.07 | -10.06 | 32.01 | 69.50 | -37.49 | peak | | |
| 2 | | 13.4040 | 55.51 | -10.10 | 45.41 | 80.50 | -35.09 | peak | | |
| 3 | * | 13.5485 | 76.67 | -10.12 | 66.55 | 90.50 | -23.95 | peak | | |
| 4 | | 13.5597 | 87.35 | -10.12 | 77.23 | 124.00 | -46.77 | peak | | |
| 5 | | 13.5730 | 73.14 | -10.12 | 63.02 | 90.50 | -27.48 | peak | | |
| 6 | | 13.7122 | 57.12 | -10.14 | 46.98 | 80.50 | -33.52 | peak | | |
| 7 | | 14.0262 | 44.25 | -10.16 | 34.09 | 69.50 | -35.41 | peak | | |

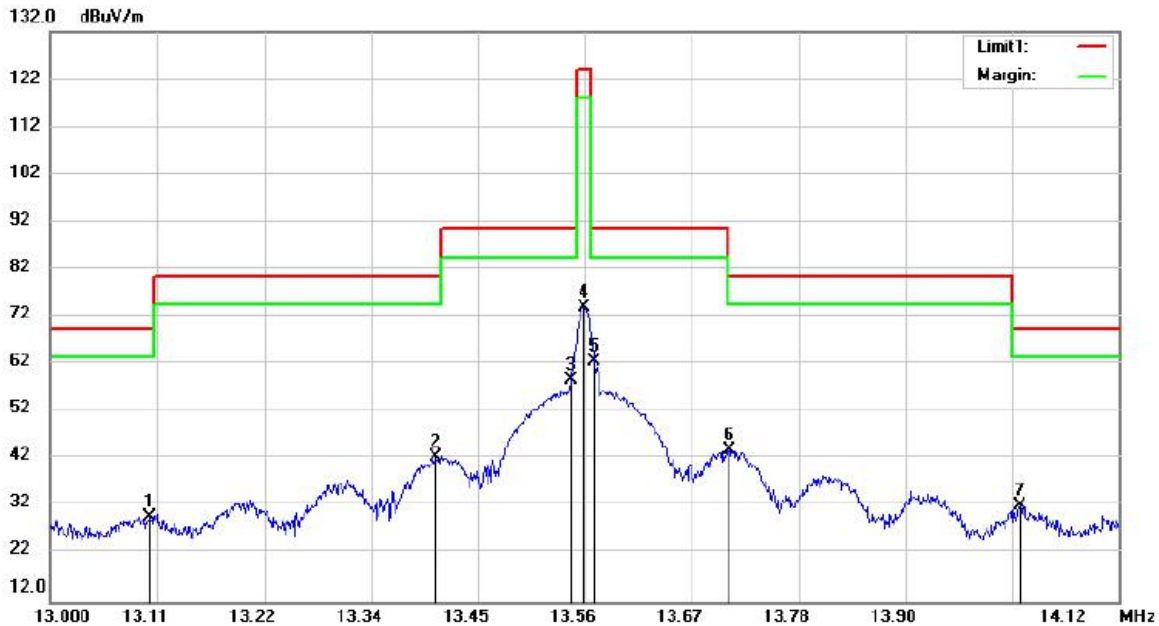

Site: 3m Chamber #1

Polarization: **Y**

Temperature: 27 C

Limit: (RE)FCC PART 15.225(Mask)

Power: AC 120V/60Hz

Humidity: 43 %

Mode: TX

Note:

| No. | Mk. | Freq. MHz | Reading Level dBuV | Correct Factor dB | Measure- ment dBuV/m | Limit dBuV/m | Over dB | Detector | Antenna Height cm | Table Degree | Comment |
|-----|-----|--------------|--------------------------|-------------------------|----------------------------|-----------------|------------|----------|-------------------------|-----------------|---------|
| 1 | | 13.1032 | 39.96 | -10.06 | 29.90 | 69.50 | -39.60 | peak | | | |
| 2 | | 13.4053 | 52.42 | -10.10 | 42.32 | 80.50 | -38.18 | peak | | | |
| 3 | | 13.5464 | 68.88 | -10.12 | 58.76 | 90.50 | -31.74 | peak | | | |
| 4 | | 13.5596 | 84.18 | -10.12 | 74.06 | 124.00 | -49.94 | peak | | | |
| 5 | * | 13.5704 | 72.68 | -10.12 | 62.56 | 90.50 | -27.94 | peak | | | |
| 6 | | 13.7115 | 53.99 | -10.14 | 43.85 | 80.50 | -36.65 | peak | | | |
| 7 | | 14.0168 | 42.26 | -10.16 | 32.10 | 69.50 | -37.40 | peak | | | |

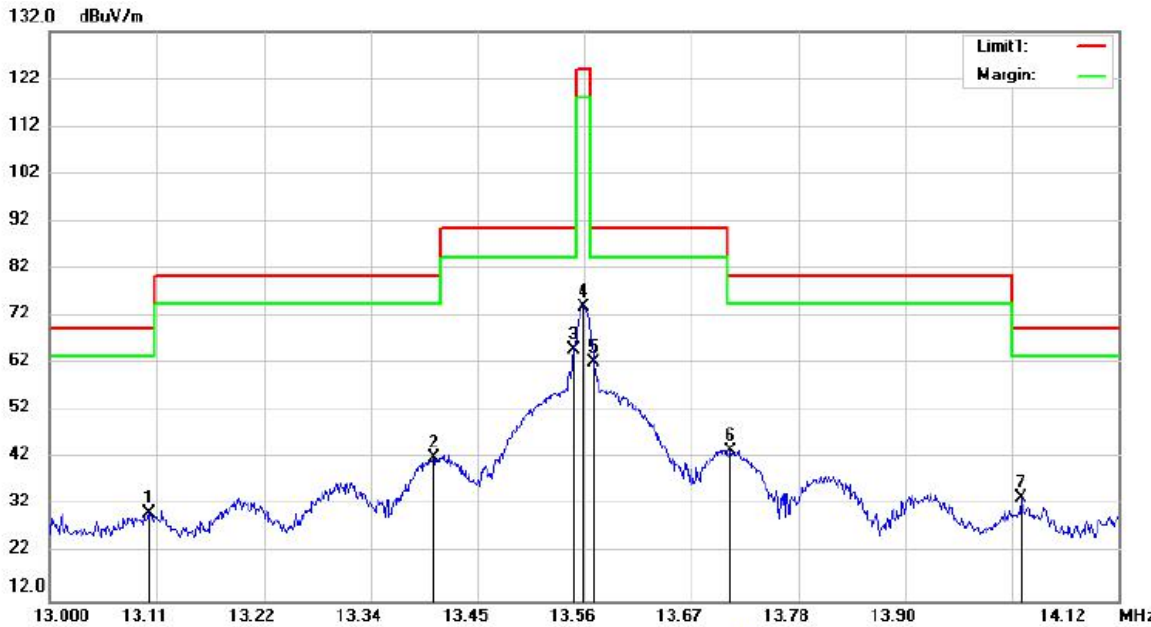

Site: 3m Chamber #1 Polarization: **Z** Temperature: 27 C
 Limit: (RE)FCC PART 15.225(Mask) Power: AC 120V/60Hz Humidity: 43 %
 Mode: TX
 Note:

| No. | Mk. | Freq. MHz | Reading Level dBuV | Correct Factor dB | Measure- ment dBuV/m | Limit dBuV/m | Over dB | Detector | Antenna Height cm | Table Degree | Comment |
|-----|-----|--------------|--------------------------|-------------------------|----------------------------|-----------------|------------|----------|-------------------------|-----------------|---------|
| 1 | | 13.1036 | 40.47 | -10.06 | 30.41 | 69.50 | -39.09 | peak | | | |
| 2 | | 13.4022 | 52.22 | -10.10 | 42.12 | 80.50 | -38.38 | peak | | | |
| 3 | * | 13.5496 | 74.93 | -10.12 | 64.81 | 90.50 | -25.69 | peak | | | |
| 4 | | 13.5597 | 84.18 | -10.12 | 74.06 | 124.00 | -49.94 | peak | | | |
| 5 | | 13.5701 | 72.25 | -10.12 | 62.13 | 90.50 | -28.37 | peak | | | |
| 6 | | 13.7140 | 53.82 | -10.14 | 43.68 | 80.50 | -36.82 | peak | | | |
| 7 | | 14.0178 | 43.81 | -10.16 | 33.65 | 69.50 | -35.85 | peak | | | |

■ Spurious Emission below 150kHz (9KHz to 150kHz)

| | | | |
|--------------|---------|------------|----|
| Temperature: | 24℃ | Test Date: | |
| Humidity: | 53 % | Test By: | KK |
| Test mode: | TX Mode | | |

| Freq. (MHz) | Ant.Pol. H/V | Emission Level(dBuV/m) | | Limit 3m(dBuV/m) | | Over(dB) | |
|----------------|-----------------|---------------------------|----|------------------|----|----------|----|
| | | PK | AV | PK | AV | PK | AV |
| -- | -- | -- | -- | -- | -- | -- | -- |

Note: the amplitude of spurious emission that is attenuated by more than 20dB below the permissible limit has no need to be reported.

Distance extrapolation factor = $40 \log(\text{Specific distance} / \text{test distance})$ (dB);

Limit line = Specific limits(dBuV) + distance extrapolation factor



■ Spurious Emission below 30MHz (150KHz to 30MHz)
 All mode have been tested, and the worst result was report as below:

| Freq. (MHz) | Ant.Pol. H/V | Emission Level (dBuV/m) | Limit 3m (dBuV/m) | Over (dB) | Note |
|-------------|--------------|-------------------------|-------------------|-----------|------|
| 3.25 | V | 31.26 | 69.54 | -38.28 | QP |
| 10.34 | V | 32.56 | 69.54 | -36.98 | QP |
| 15.18 | V | 33.67 | 69.54 | -35.87 | QP |
| 16.69 | V | 34.15 | 69.54 | -35.39 | QP |
| 21.35 | V | 36.29 | 69.54 | -33.25 | QP |
| 24.32 | V | 37.48 | 69.54 | -32.06 | QP |
| | | | | | |
| 3.15 | H | 31.25 | 69.54 | -38.29 | QP |
| 8.67 | H | 32.64 | 69.54 | -36.9 | QP |
| 11.16 | H | 35.68 | 69.54 | -33.86 | QP |
| 16.68 | H | 36.61 | 69.54 | -32.93 | QP |
| 21.34 | H | 32.28 | 69.54 | -37.26 | QP |
| 26.57 | H | 45.16 | 69.54 | -24.38 | QP |

■ Spurious Emission Above 30MHz (30MHz to 1GHz)

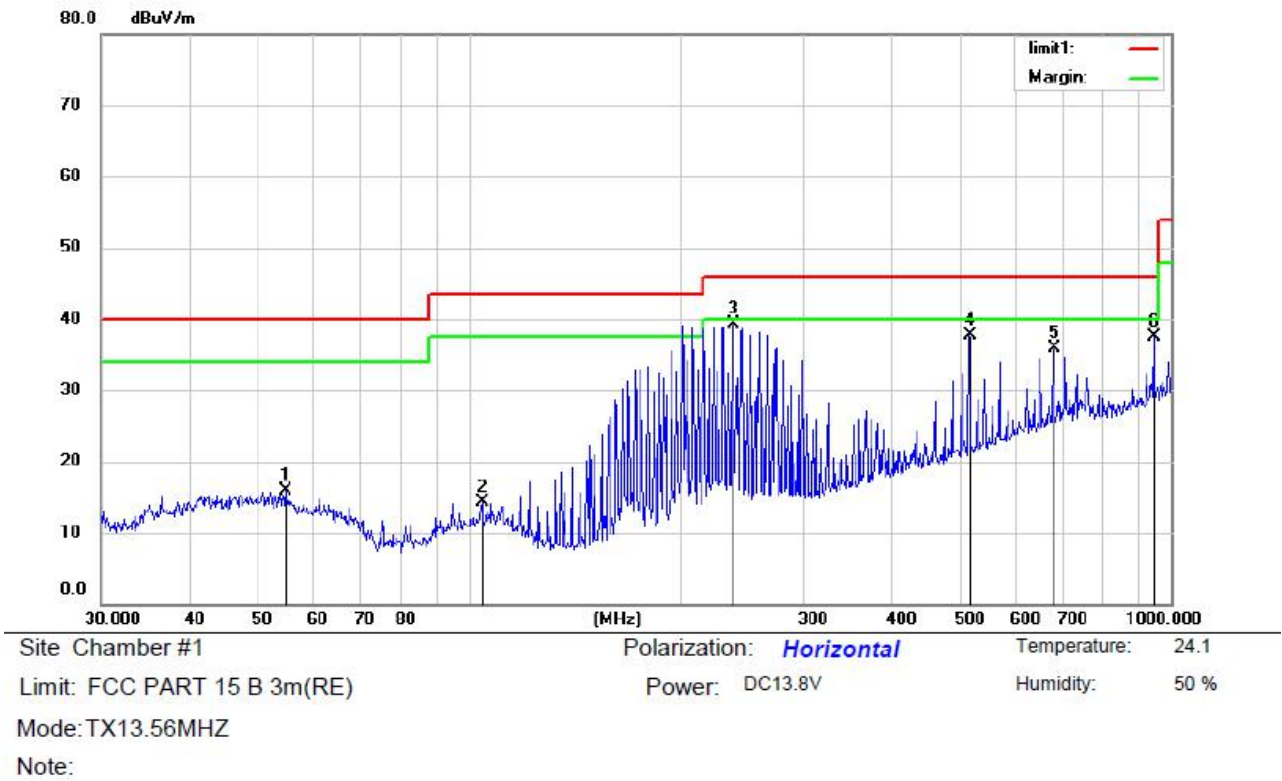

| No. | Mk. | Freq. MHz | Reading Level dBuV | Correct Factor dB | Measure- ment dBuV/m | Limit dBuV/m | Over dB | Detector | Antenna Height cm | Table Degree | Comment |
|-----|-----|--------------|--------------------------|-------------------------|----------------------------|-----------------|------------|----------|-------------------------|-----------------|---------|
| 1 | | 54.8348 | 31.85 | -15.93 | 15.92 | 40.00 | -24.08 | QP | | | |
| 2 | | 104.5361 | 32.47 | -18.22 | 14.25 | 43.50 | -29.25 | QP | | | |
| 3 | * | 237.4760 | 55.25 | -15.92 | 39.33 | 46.00 | -6.67 | QP | | | |
| 4 | | 515.4374 | 46.30 | -8.61 | 37.69 | 46.00 | -8.31 | QP | | | |
| 5 | | 679.9600 | 40.52 | -4.69 | 35.83 | 46.00 | -10.17 | QP | | | |
| 6 | | 945.4400 | 38.12 | -0.62 | 37.50 | 46.00 | -8.50 | QP | | | |

*:Maximum data x:Over limit !:over margin

Operator: Tom

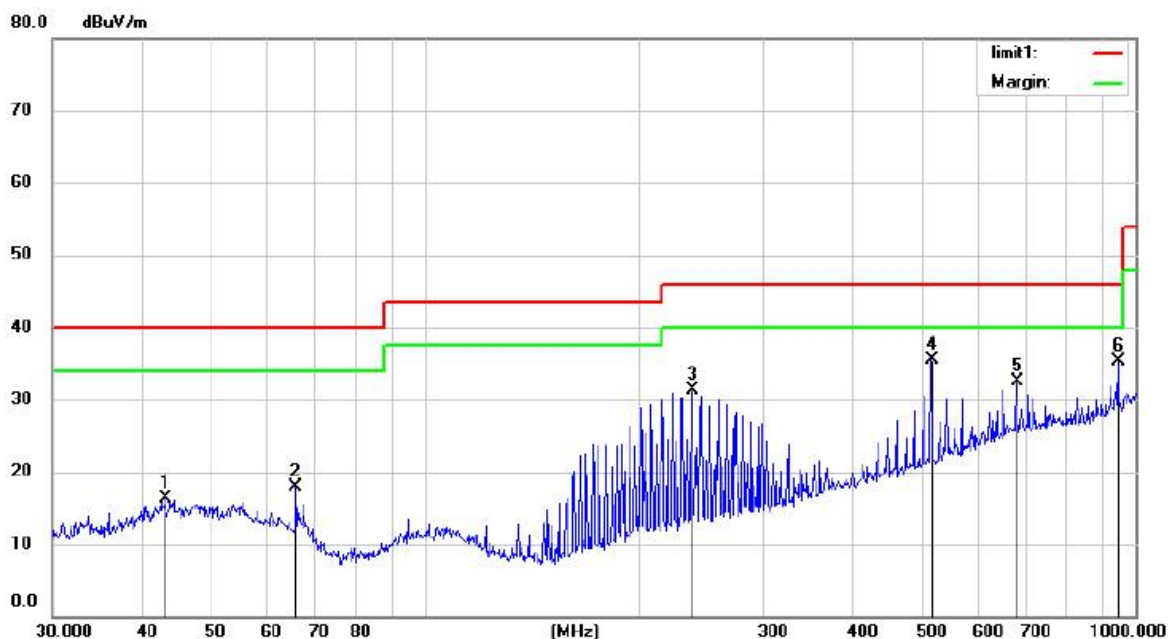

Site Chamber #1

 Polarization: *Vertical*

Temperature: 24.1

Limit: FCC PART 15 B 3m(RE)

Power: DC13.8V

Humidity: 50 %

Mode: TX13.56MHZ

Note:

| No. | Mk. | Freq. MHz | Reading Level dBuV | Correct Factor dB | Measure- ment dBuV/m | Limit dBuV/m | Over dB | Antenna Height cm | Table Degree | Detector | Comment |
|-----|-----|--------------|--------------------------|-------------------------|----------------------------|-----------------|------------|-------------------------|-----------------|----------|---------|
| 1 | | 43.2017 | 32.27 | -16.05 | 16.22 | 40.00 | -23.78 | | | QP | |
| 2 | | 66.0342 | 36.07 | -18.14 | 17.93 | 40.00 | -22.07 | | | QP | |
| 3 | | 237.4760 | 47.25 | -15.92 | 31.33 | 46.00 | -14.67 | | | QP | |
| 4 | * | 515.4374 | 44.15 | -8.61 | 35.54 | 46.00 | -10.46 | | | QP | |
| 5 | | 679.9600 | 37.20 | -4.69 | 32.51 | 46.00 | -13.49 | | | QP | |
| 6 | | 945.4400 | 35.91 | -0.62 | 35.29 | 46.00 | -10.71 | | | QP | |

*:Maximum data x:Over limit !:over margin

Operator: Tom

■ Radiated Measurement Photos:

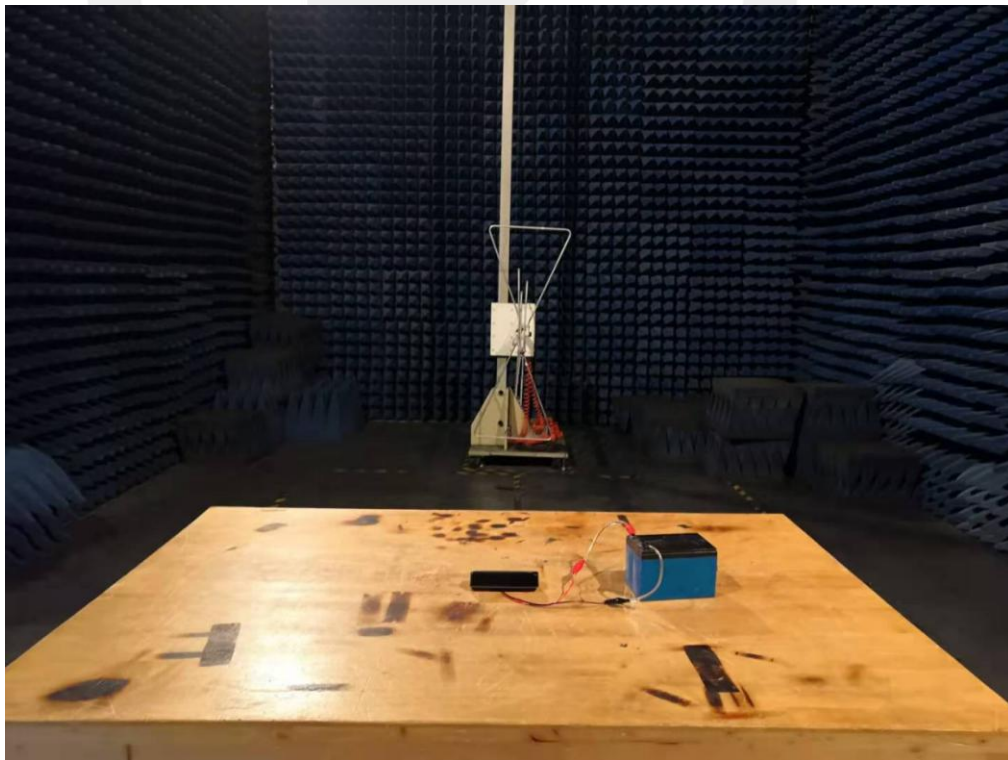
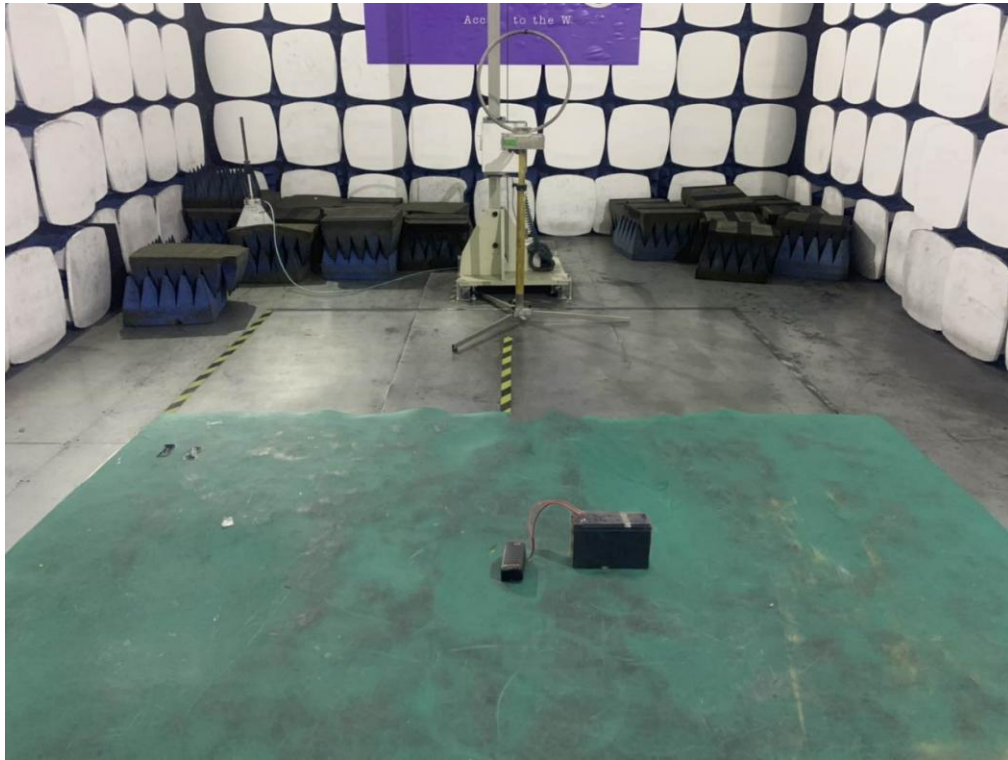

7.4 CONDUCTED EMISSION TEST

7.4.1 Applicable Standard

According to FCC Part 15.207(a)

7.4.2 Conformance Limit

| Conducted Emission Limit | | |
|--------------------------|------------|---------|
| Frequency(MHz) | Quasi-peak | Average |
| 0.15-0.5 | 66-56 | 56-46 |
| 0.5-5.0 | 56 | 46 |
| 5.0-30.0 | 60 | 50 |

Note: 1. The lower limit shall apply at the transition frequencies
 2. The limit decreases in line with the logarithm of the frequency in the range of 0.15 to 0.50MHz.

7.4.3 Test Configuration

Test according to clause 7.3 conducted emission test setup

7.4.4 Test Procedure

The EUT was placed on a table which is 0.8m above ground plane.
 Maximum procedure was performed on the highest emissions to ensure EUT compliance.
 Repeat above procedures until all frequency measured were complete.

7.4.5 Test Results

N/A

Note: The product is DC powered.

8 ANTENNA APPLICATION

8.1 ANTENNA REQUIREMENT

| Standard | Requirement |
|---------------------|--|
| FCC CRF Part 15.203 | An intentional radiator shall be designed to ensure that no antenna other than that furnished by the responsible party shall be used with the device. The use of a permanently attached antenna or of an antenna that uses a unique coupling to the intentional radiator shall be considered sufficient to comply with the provisions of this section. The manufacturer may design the unit so that a broken antenna can be replaced by the user, but the use of a standard antenna jack or electrical connector is prohibited. This requirement does not apply to carrier current devices or to devices operated under the provisions of §15.211, §15.213, §15.217, §15.219, or §15.221. Further, this requirement does not apply to intentional radiators that must be professionally installed, such as perimeter protection systems and some field disturbance sensors, or to other intentional radiators which, in accordance with §15.31(d), must be measured at the installation site. However, the installer shall be responsible for ensuring that the proper antenna is employed so that the limits in this part are not exceeded. |

For intentional device, according to FCC 47 CFR Section 15.203, an intentional radiator shall be designed to ensure that no antenna other than that furnished by the responsible party shall be used with the device. if transmitting antennas of directional gain greater than 6dBi are used, the power shall be reduced by the amount in dB that the directional gain of the antenna exceeds 6dBi.

8.2 RESULT

The EUT'S antenna is coil antenna, The antenna's gain is 0dBi and meets the requirement. and the antenna can't be replaced by the user, which in accordance to section 15.203.



APPENDIX I (Photos of EUT)







