

Qingdao Magene Intelligence Technology Co., Ltd.

User Manual



eBike TFT Display DY30

Model: P0203320

1. Product Introduction

- Category: eBike TFT Display
- Model: P0203320
- Appearance:



- Specification:

Rated Voltage (DCV)	36V/48V
Working Temp(°C)	-20~50
Storage Temp(°C)	-25~55
Waterproof Level	IPX7
Display Type	TFT
Resolution Ratio	240*320
Assist Level (Riding Mode)	4 Assist Level (Riding Mode), including AUTO mode
Walk Assistance	Available
Light On/Off Function	Available
Button/Function Tone	Available
Light Sensor	Available
Electronic Shifting Interaction	Available
Radar Interaction	Available
Landscape Screen / Vertical Screen	Available
APP	Available
Communication	CAN、BLE
Upgrading	OTA
Display content	Assist Level, Time, Error Code, Light Icon, BLE Icon, Battery Capacity, Riding Mode, Speed, Rider/Motor Power Ratio, Shifting Gear, Range, Trip, Riding Time, Avg Speed, Max Speed, Calory, Evg Power, Energy Consumption, Screen Brightness, Battery Discharge Method

2. Dimension

● Display

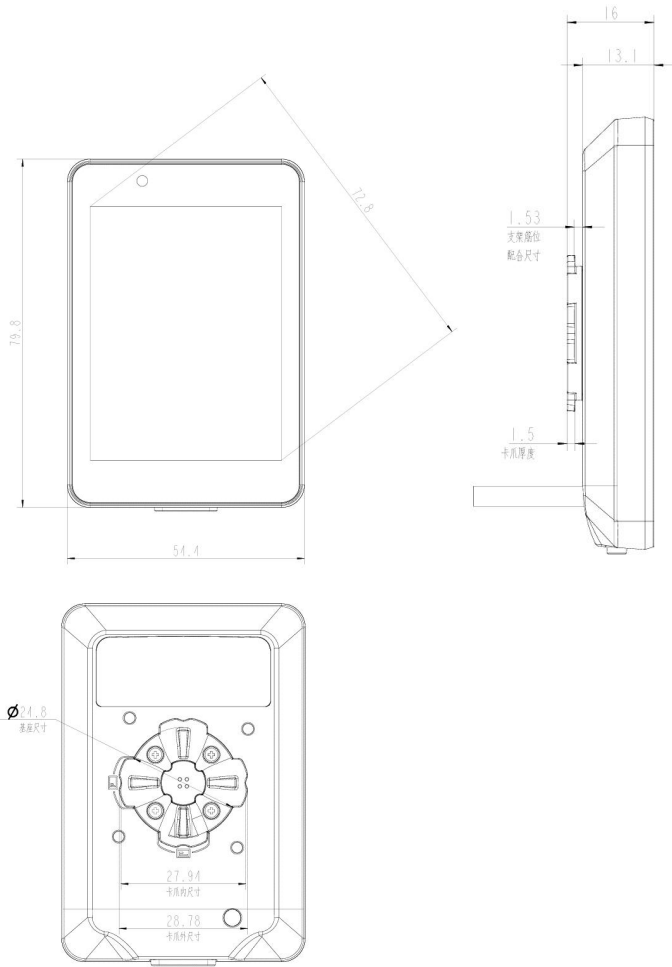

Display Size 79.8*54.4*16mm

● Display Support

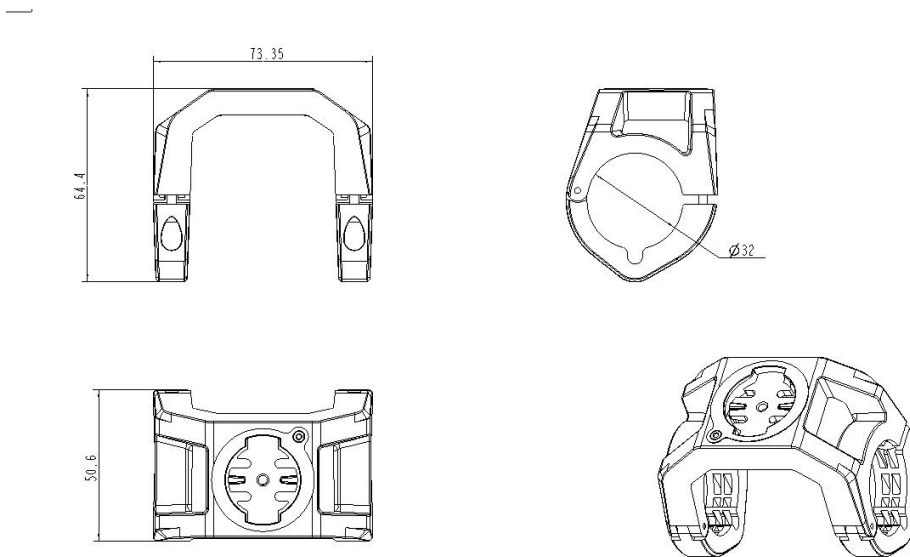

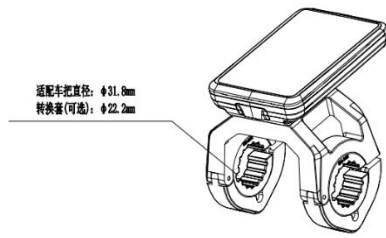

Display support Size: 73.35*50.6*64.4mm, adapted handlebar diameter: 31.8mm (22.2mm is also available with rubber cover)

● Pin Connection Definition

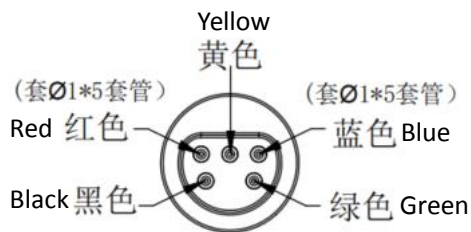

Category	No.	Color	Definition
Pin Connection	1	Red	Battery
	2	Black	GND
	3	Yellow	CANL
	4	Green	CANH
	5	Blue	IO/Lock Line

3. Display Introduction



① Status

Including: Assist Level, Time, Error Icon, Light Icon, BLE Icon, Battery

- Assist Level (Riding Mode): AUTO, ECO, TOUR, TURBO total 4 normal assist level (Riding mode), another 1 level stands for walk assistance function
- Time: It shows current time

- Error Icon: It shows current error
- Light Icon: The icon appears and disappears along with light/Backlight on/off operation
- BLE Icon: It always appears on the screen when display is power on, it means BLE is on working
- Battery Capacity: It shows the percentage of battery
- ② Home Page: Riding mode, Speed, Rider/Motor Power Ratio, Shifting Gear, Range, Trip
 - Riding Mode: AUTO, ECO, TOUR, TURBO 4 modes, 1 mode stands for walking assistance
 - Speed: Current Speed, It switches along with riding data switching operation, SPEED is default data showing on the display when the display is power on
 - Rider/Motor Power Ratio: Power ratio between rider and motor
 - Shifting Gear: It shows current shifting gear
 - Range: It shows the distance cyclist can still ride
 - Trip: Trip distance, the trip distance starts when the display is power on and ends when the display is power off

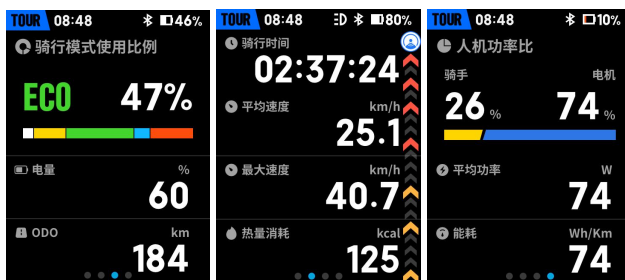

- ③ Data Page: Riding Time, Avg Speed, Max Speed, calory, Rider Motor Power Ratio, Avg Power, Power Consumption
 - Riding Time: The trip time starts when the display is power on and ends when the display is power off
 - Avg Speed: Average Speed in one trip
 - Max Speed: Max Speed in one trip
 - Calory: Calory consumption in one trip
 - Rider Motor Power Ratio: Power ratio between rider and motor in one trip
 - Avg Power: Average power in one trip
 - Power Consumption: Average power consumption in one trip

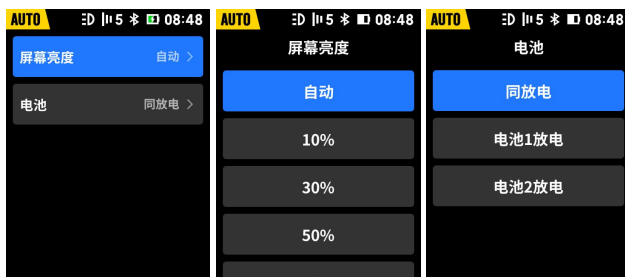

- ④ Setting Page: Screen Brightness, Battery Discharge Method
 - Screen Brightness: It can select manually / automatically to switch screen brightness, as well as the percentage of screen brightness under manual switching
 - Battery Discharge Method: It can select two batteries discharge together / Battery 1 Discharge / Battery 2 Discharge

4. Controlling Button Introduction



Including: 3 Buttons, “+”, “-”, “M/⌄”

Operation: One button short pressing, one button long pressing, combination buttons long pressing



Including: 1 button, “⌄”

Operation: One button short pressing, one button long pressing, one button double-click

5. Function Introduction

1) Display DY30 working with single display DY12



① Power On/Off

Power On: Long pressing DY30 “” 2s or DY12 “M/” 2s when the display is power off

Power Off: Long pressing DY30 “” 2s or DY12 “M/” 2s when the display is power on

② Riding Modes Switching Operation

When there is electronic shifting module: Short pressing DY12 “M/” to loop switch riding mode

When there isn't electronic shifting module: Short pressing DY12 “+/-” to switch riding mode

Riding Mode	DY12 LED Color / DY30 Mode Color	Remark
OFF	White/White	No Assist
AUTO	Yellow/Yellow	Auto Assist
ECO	Green/Green	Lowest Assist Mode
TOUR	Blue/Blue	Mid Assist Mode
TURBO	Red/Red	Highest Assist Mode
WALK	None/Purple	Walk Assist

③ Data Page Switching

Short pressing DY30 “” to loop switch riding data



② Light On/Off Operation

Long pressing DY12 “+” 2s to power on light, long pressing DY12 “+” 2s again to power off light





⑤ Walk Assistance Operation

Pressing DY12 “-” 2s and hold it to start walk assistance mode, then release “-” to stop walk assistance mode

⑥ Shifting Gear Switching

When there is electronic shifting module: Short pressing DY12 “+/-” to switch shifting gear, short pressing “+” to switch to small freewheel; Short pressing “-” to switch to big freewheel

⑦ Function Of Setting Page

Double clicking DY30 “”, it entries setting page, including screen brightness setting, battery discharge method, short pressing DY12 “-” to loop switch from up and down, short pressing DY12 “+” to entry subpage, short pressing DY12 “M/” / DY30 “” to return previous page, pressing DY12 “M/” / DY30 “” to exit setting page

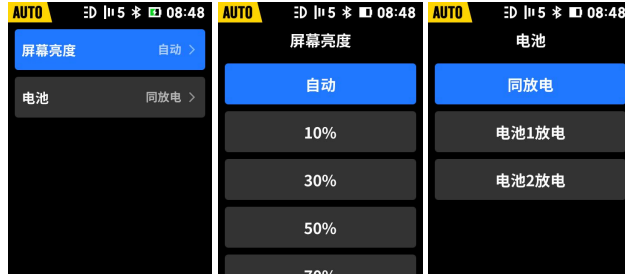

6.Error Code Definition

When there is fault in eBike system, 4 LED of DY12 power on and flash

Error Code	Fault	Solution
102	Under Voltage	Checking the battery and charge it
103	Phase current over current	If this fault always appear, just check eBike controller or motor, it may be broken
105	Lack phase of motor	① Checking the cable and connector between eBike controller and motor, the cable maybe broken or connector become less crowded eBike motor or controller is broken, it needs change eBike motor or controller
106	Short circuit of motor	① Checking the cable and connector between eBike controller and motor, the cable maybe broken or connector become less crowded eBike motor or controller is broken, it needs change eBike motor or controller
107	Lock rotor of motor	Over load or exceeding the uphill ability when the cyclist riding, it can recover when removing load or riding within the requirements of uphill ability
108	Hall anomaly	① Checking the cable and connector between eBike controller and motor, the cable maybe broken or connector become less crowded, Hall sensor is broken, it needs change motor
109	Controller over heat	Over load or exceeding the uphill ability when the cyclist riding, it can recover when removing load or riding within the requirements of uphill ability
110	Throttle anomaly	① Checking the cable and connector between eBike controller and throttle, the cable maybe broken or connector become less crowded, Throttle is broken, it needs change throttle

111	Communication fault (Digit torque sensor)	① Checking the cable and connector between eBike controller and torque sensor, the cable maybe broken or connector become less crowded eBike controller or torque sensor is broken, it needs change eBike controller or torque sensor
115	Temp sensor fault of controller	Sensor is broken, it needs change controller
001	Communication fault (Display)	① Checking the cable and connector between eBike controller and display, the cable maybe broken or connector become less crowded eBike controller or display is broken, it needs change eBike controller or display
002	Storage fault (Display)	Display is broken, it needs change display

7. Mounting Instruction

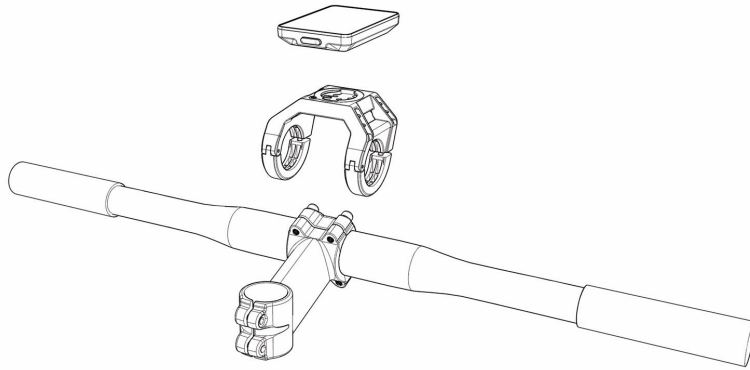

- ① Firm display support on the handle bar, tightening the screws

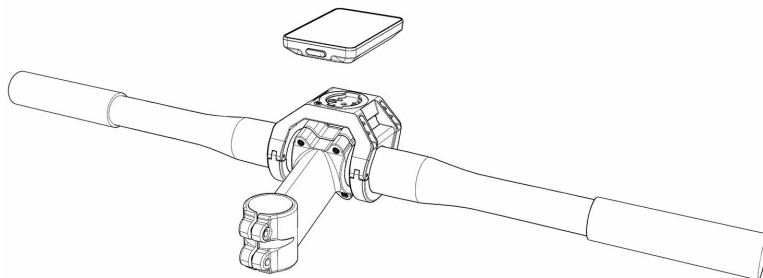
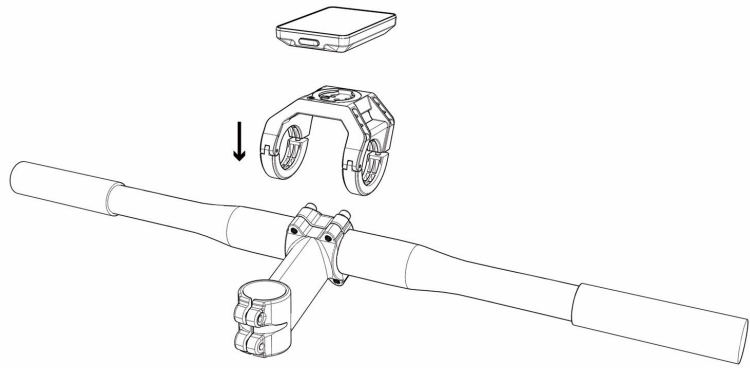

- ② Rotating the display on the support and finish mounting

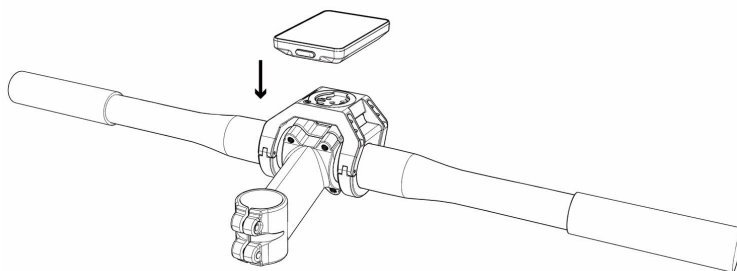

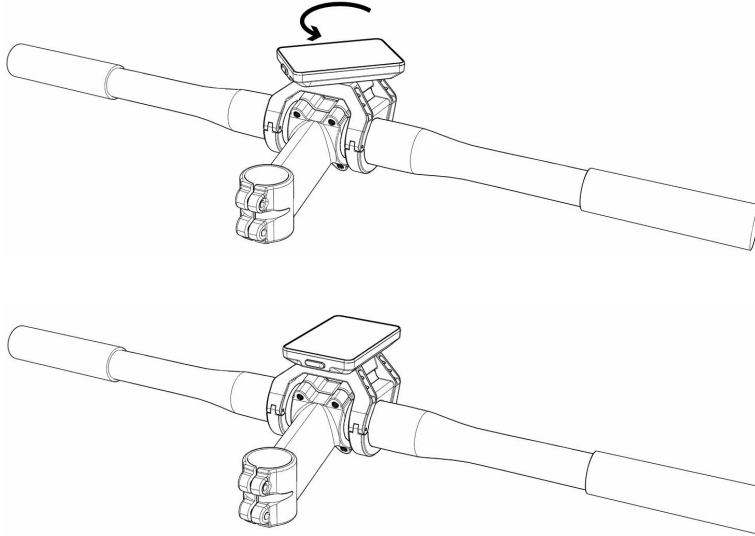

- ③ Display DY30 can be switched to landscape screen , unscrewing 4 screws on the buckle of back of display and rotating the buckle 90 ° , then tightening the screws , rotating the display on the support and finish display screen switching (Note: Landscape setting should be done on the APP)

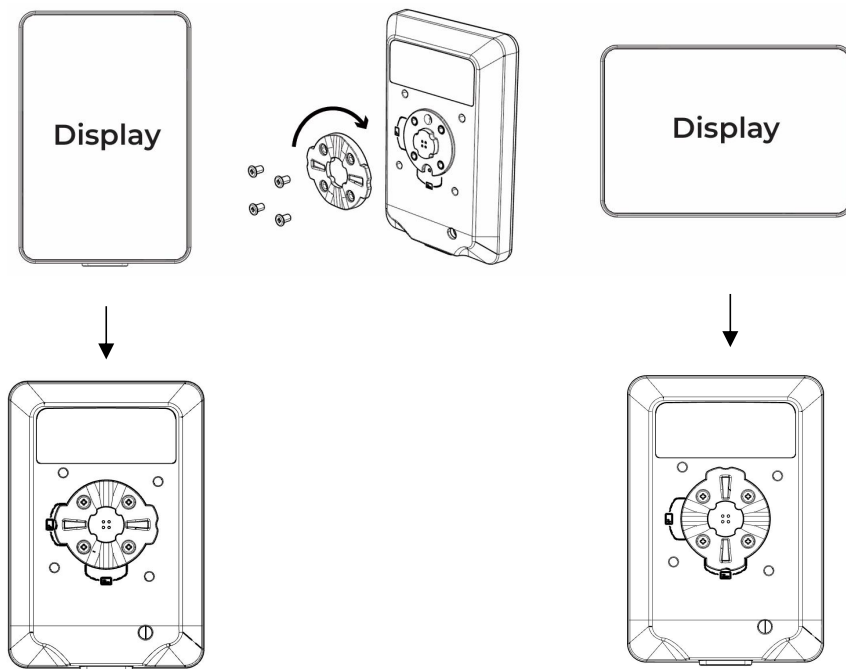

8、FCC Statements

■ FCC Statements

This device complies with part 15 of the FCC rules. Operation is subject to the following two conditions:

- (1) this device may not cause harmful interference, and
- (2) this device must accept any interference received, including interference that may cause undesired operation.

NOTE: The manufacturer is not responsible for any radio or TV interference caused by unauthorized modifications or changes to this equipment. Such modifications or changes could void the user's authority to operate the equipment.

NOTE: This equipment has been tested and found to comply with the limits for a Class B digital device, pursuant to part 15 of the FCC Rules. These limits are designed to provide reasonable protection against harmful interference in a residential installation. This equipment generates uses and can radiate radio frequency energy and, if not installed and used in accordance with the instructions, may cause harmful interference to radio communications. However, there is no guarantee that interference will not occur in a particular installation. If this equipment does cause harmful interference to radio or television reception, which can be determined by turning the equipment off and on, the user is encouraged to try to correct the interference by one or more of the following measures:

- Reorient or relocate the receiving antenna.
- Increase the separation between the equipment and receiver.
- Connect the equipment into an outlet on a circuit different from that to which the receiver is connected.
- Consult the dealer or an experienced radio/TV technician for help.

RF Warning:

The device has been evaluated to meet general RF exposure requirement, The device can be used in portable exposure condition without restriction. Federal Communication Commission (FCC) Radiation Exposure Statement Power is so low that no RF exposure calculation is needed.