

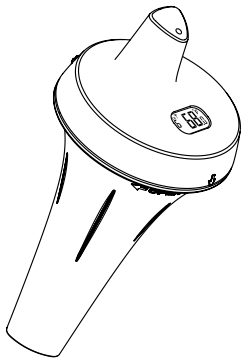

CCL ELECTRONICS LTD

LONG RANGE WIRELESS FLOATING POOL & SPA SENSOR Model: C3107B User Manual



Thank you for selecting this delicate pool & SPA sensor. Utmost care has gone into the design and manufacture of the sensor. Please read the instructions carefully according to the version you purchased and keep the manual well for future reference.

OVERVIEW

WIRELESS THERMO POOL SENSOR

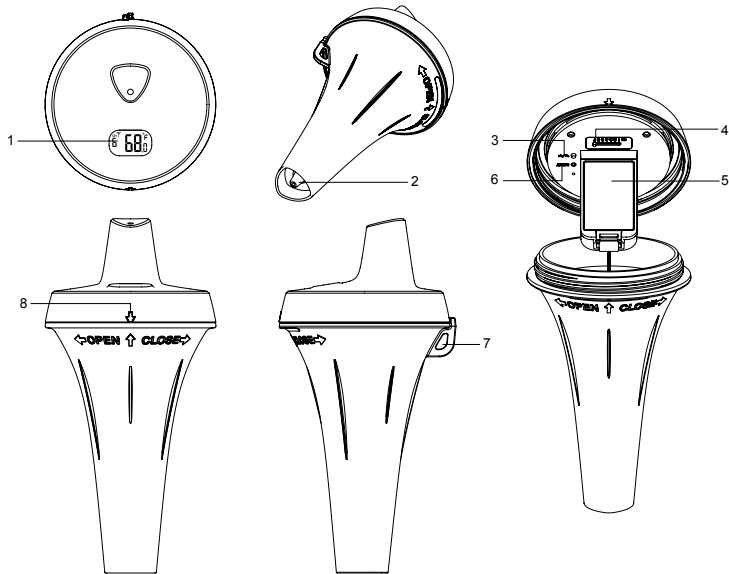

1. LCD display
2. Thermo sensor
3. [°C / °F] key
4. [CHANNEL] slide switch
5. Battery compartment
 - Accommodates 2 x AA size batteries.
6. [RESET] key
7. Wire hole
8. Top case lock indicator

GETTING STARTED

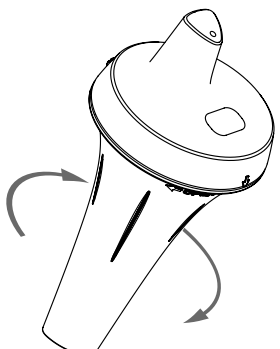
<ol style="list-style-type: none"> 1. Turn the bottom case anti-clockwise to open. 	
---	---

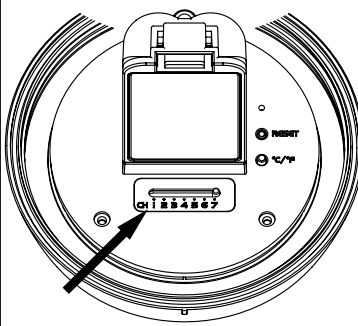
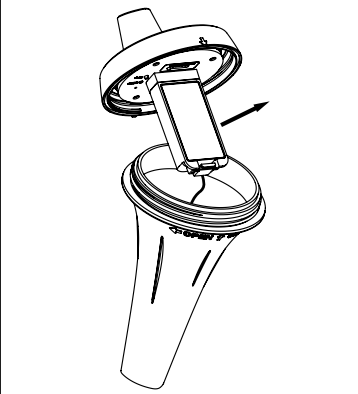
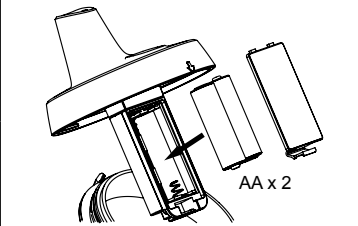
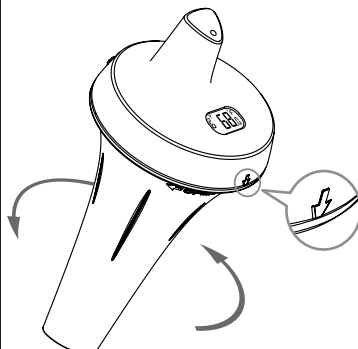
<ol style="list-style-type: none"> 2. Select the sensor channel. 	
<ol style="list-style-type: none"> 3. Remove the battery door. 	
<ol style="list-style-type: none"> 4. Insert 2 x AA size batteries into the battery compartment. Make sure you insert them the right way according to the polarity information marked on the battery compartment. 	
<ol style="list-style-type: none"> 5. Close the battery door. 	
<ol style="list-style-type: none"> 6. Twist the bottom case clockwise and make sure the top and button lock indicator align to complete the setup. 	

NOTE:
 Ensure the water tight O-ring is properly aligned in place to ensure water resistant.

- Do not twist the sensor cable and keep it straight.
- Once the channel is assigned to a Wireless thermo sensor, you can only change it by removing the batteries or resetting the unit.
- After replacing the batteries of the wireless thermo sensor or the unit fails to receive wireless sensor signal of a specified channel, press [SENSOR] key on the console unit to manually receive the sensor signal again.

LCD DISPLAY ON THE SENSOR

Once the sensor power up, you can find the following information that show on the sensor's LCD display.

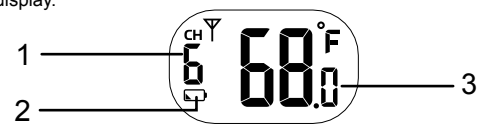





1. Current channel of the sensor (e.g. switch to channel "6")
2. Low battery indicator
3. Current Temperature reading

WIRELESS SENSOR SIGNAL RECEIVING (DISPLAY CONSOLE)

This pool sensor can support different 7CH console, user can base on the following step to setup the display console.

1. In normal mode, press the console [SENSOR] key once to start receiving the sensor signal of current on displaying channel. The signal icon will flash.
 For example, when CH 6 is displayed, pressing [SENSOR] key will start receive for CH 6 only.
2. The signal icon will flash until the reception succeeded. If no signal is received within 5 minutes the icon will disappear.

The icon blinks once every time when incoming wireless sensor signal is received (every 60s)	 OUT
Fair wireless sensor signal	 OUT
Weak wireless sensor signal	 OUT
Bad / no wireless sensor signal	 OUT

- If the signal for **Ch 1~7** has discontinued and does not recover within 15 minutes, the temperature and humidity will display "Er" for the corresponding channel.
- If the signal does not recover within 48 hours, the "Er" display will become permanent. You need to replace the batteries of the "Er" channel's sensors and then press [**SENSOR**] key to pair up with the sensors per each "Er" channel again.

NOTE:

The operation or signal icons of different display consoles may be different, please refer to the user manual of your display console for more detail.

SENSOR PLACEMENT

Place the sensor in the pool within 30 meters (100 feet) of the display console and avoid side wall of the pool block the sensor signal.

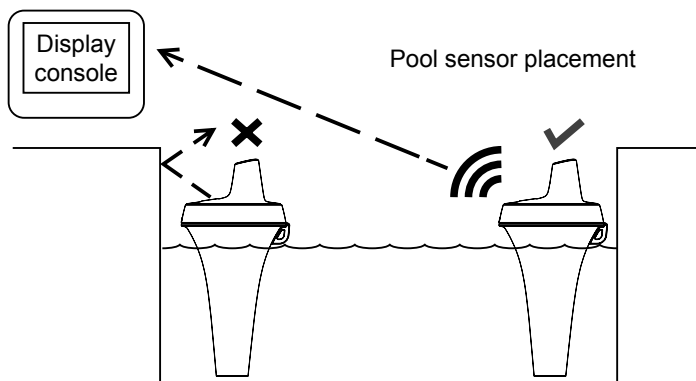

LOW BATTERY ICON

If the sensor is low in battery, the low battery icon "  " will display on the LCD of the sensor and display console.

NOTE:

On the display console, the low battery icon will only appear when the corresponding channel is displaying.

PRECAUTIONS WHEN OPENING AND CLOSING THE SENSOR CASING

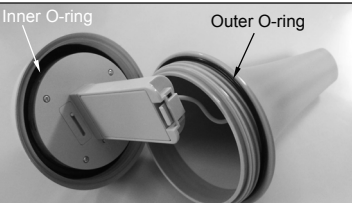
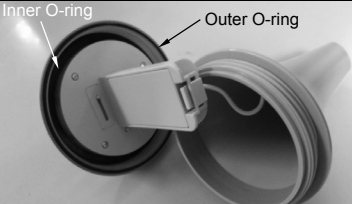
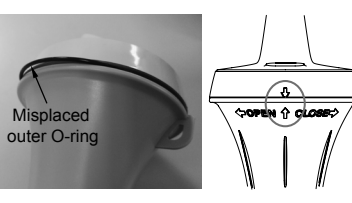
	<p>1. Opening the casing:</p> <ul style="list-style-type: none"> - Unscrew the bottom casing carefully in direction indicated - There are 2 o-rings , one inner and one outer in blue color between the 2 casings - The outer O-ring may drop down and rest on the bottom casing.
	<p>2. Before closing the casing:</p> <ul style="list-style-type: none"> - Ensure the unit is wiped dry completely or leave to dry to avoid trapping any moisture inside - Carefully place both O-rings back into their respective grooves, and apply water-tightness jell/grease if necessary
	<p>3. Closing the casing:</p> <ul style="list-style-type: none"> - Ensure the outer O-ring is not misplaced (as shown) when closing the casing - Close the casing tightly such that the 2 vertical arrows aligned vertically and pointing to each other (circled in gray) - Water droplets may condense on the LCD if moisture is trapped inside the unit. Just leave the unit open and let the droplet evaporate naturally before closing the casings

IMPORTANT NOTE

- Read and keep these instructions.
- Do not subject the unit to excessive force, shock, dust, temperature or humidity.
- Do not cover the ventilation holes with any items such as newspapers, curtains etc.
- Do not clean the unit with abrasive or corrosive materials.
- Do not tamper with the unit's internal components. This invalidates the warranty.
- Only use fresh batteries. Do not mix new and old batteries.
- Do not dispose old batteries as unsorted municipal waste. Collection of such waste separately for special treatment is necessary.
- Attention! Please dispose of used unit or batteries in an ecologically safe manner.
- Technical specifications and user manual contents for this product are subject to change without notice.



SPECIFICATIONS

Dimensions (W x H x D)	100 x 207.5 x 100 mm
Main power	2 x AA size 1.5V batteries (Alkaline battery recommended)
Operating temperature range	-5°C ~ 60°C (-23°F ~ 140°F) do not recommend under freeze condition
RF frequency	915 MHz for US
RF Transmission interval	60 seconds
RF transmission range	Up to 30 m (100 feet) line of sight

This device complies with Part 15 of the FCC Rules. Operation is subject to the following two conditions: (1) this device may not cause harmful interference, and (2) this device must accept any interference received, including interference that may cause undesired operation.

Warning: Changes or modifications to this unit not expressly approved by the party responsible for compliance could void the user's authority to operate the equipment.

NOTE: This equipment has been tested and found to comply with the limits for a Class B digital device, pursuant to Part 15 of the FCC Rules. These limits are designed to provide reasonable protection against harmful interference in a residential installation. This equipment generates, uses and can radiate radio frequency energy and, if not installed and used in accordance with the instructions, may cause harmful interference to radio communications.

However, there is no guarantee that interference will not occur in a particular installation. If this equipment does cause harmful interference to radio or television reception, which can be determined by turning the equipment off and on, the user is encouraged to try to correct the interference by one or more of the following measures:

- Reorient or relocate the receiving antenna.
- Increase the separation between the equipment and receiver.
- Connect the equipment into an outlet on a circuit different from that to which the receiver is connected.
- Consult the dealer or an experienced radio/TV technician for help.