

GC9838-LR - INTELLIGENT HYBRID PLC-RF DIN RAIL MODEM



Overview

Power-line communications (PLC) and low-cost Radio Frequency (RF) networking can suffer from high noise and attenuation due to environmental factors which often cause communication links between two nodes to vary significantly in quality. A communication link which may be optimal on certain medium and channel at a given time may become sub-optimal as time passes resulting in breakdown of the network. In certain cases, communication can be totally disrupted due to interferences or breakdown in the medium. For example, in the case of PLC, a transformer or a physical discontinuity in the power line would impede communications while metallic and concrete objects to the extent of weather (humidity, rain, lightning etc.) can block or affect the quality of wireless communication.

The gridComm GC9838-LR is a next generation hybrid DIN Rail Power Line Communication - Radio Frequency modem providing complete hardware and software networking solution. It automatically configures the PLC and RF real-time and self-adapts to the varying conditions in the communication links with the most optimal data routing paths, resulting in extremely reliable and robust communications in a Low-Voltage power network. This new generation GC9838-LR DIN Rail hybrid PLC-RF modem utilizes the industry-leading gridComm GC2200 Integrated circuit, an OFDMA (Orthogonal Frequency Division Multiple Access) Power Line Communication Transceiver

and a built-in sub-GHz wireless module to allow adaptive networking over different media. The wireless connectivity can be available in LoRa for tree-structure network or gridComm proprietary VE mesh-structure network.

Benefits

By taking advantage of its inherent 18 independent PLC channels and the additional 19th RF channel, the GC9838-LR is able to communicate over PLC and RF concurrently via gridComm GCNet network. This brings upon the benefits of operating in a single unified communication network using common communication protocol, command sets and ID addressing scheme. This not only enables the GC9838 to serve as an automatic bridge or range extender but, at the same time, also allows it to connect with discrete PLC or RF devices which can be extremely useful in IoT sensor applications.

The 18 PLC channels are capable of operating with up to 54 carrier frequencies over a wide frequency range from 5KHz to 500KHz on the power lines whilst the 19th RF channel operates on industrial-strength ISM frequency bands. The new GC9838-LR is capable of communicating via low voltage power network of up to 2 Km in range in either PLC or RF modes. The GC9838-LR is ideal for applications such as Industrial Automation, Automatic Meter Reader (AMR), M2M and other applications that require extremely reliable and robust communication links.

The GC9838-LR is also equipped with a set of Digital Input and Dry Contact Relay controlling up to 2KW AC power output. By making use of gridComm [GCNet Network Management Command APIs](#) or [gridComm PLCM Utility tool](#)¹, the user can attach a sensor tied to the Digital Input for trigger-based event scenarios. Likewise, the user can also perform remote On/Off switching for a motor or any electrical device.

Note 1: For availability of the Digital Input and Dry Contact Relay GCNet APIs and PLCM Utility tool, please contact gridComm.

Auto Network Applications

The GC9838-LR is optimized for network topologies such as star or tree configurations (PLC/wireless modes). With gridComm VE wireless module, the RF link layer can be implemented in a "Tree and Mesh" network structure.

Figure 1 shows a simple hybrid PLC-RF network system connected with five modems installed in a "Star" configuration. Figure 2 shows a hybrid "Tree" network with PLC and wireless nodes. Figure 3 shows a hybrid PLC and wireless nodes in "Tree and Mesh" network.

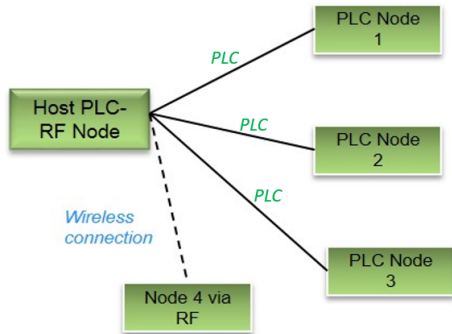

Figure 1 - "Star"-Shaped Network

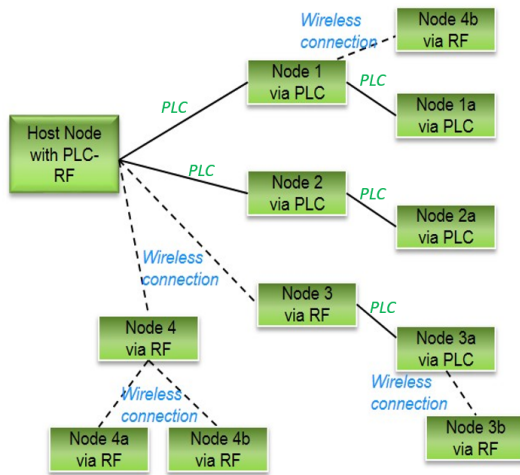

Figure 2 - "Tree" Structure

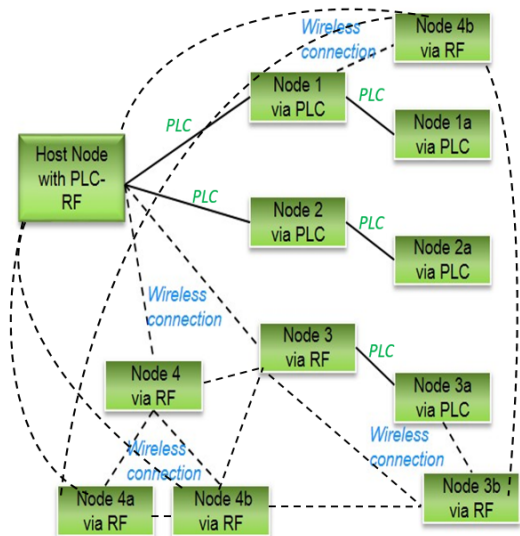

Figure 3 - "Tree & Mesh" Structure

Features and Specifications

- Connects directly to Low-Voltage AC power line
- Input power supply: Options for 90VAC~ 277VAC, 50/60 Hz, 100mA
- Operating Temperature -40°C to +85°C
- Standards: CE , FCC
 - ✓ EMC: test as per EN 50065-1, EN 55022, EN 55024, EN 61000-3-2, EN 61000-3-3, EN 61000-6-2 & EN 61000-6-4 FCC Part 15B
 - ✓ Safety: EN 60950
 - ✓ Euro RoHS
 - ✓ IP 40
- Size in mm: 71 L x 54.5 W x 75 H, Weight: 350 g
- Flame Retardant ABS casing with DIN Rail mounting
- Supports RS485 via transparent protocol
- 32-bit addressing scheme
- Four operation modes: Point-to-Point, Simple Broadcast, Auto-Routing, and Broadcast-Routing
- One master node supports up to 240 slave nodes in Auto-Routing and Broadcast-Routing modes
- Support user packet size of up to maximum of 512 bytes
- Distance: Up to 2km- actual distance depends on environments
- Interface:
 - PWM outputs- 150ps
 - Dry Contact Relay control for up to 2KW AC power output
 - RS485, no external interface converter needed
- Preset Serial COM Port settings: 115200 Baud rate, No Parity Bit, 8 Data Bit and 1 Stop Bit
- **OFDMA Power Line Communications:**
 - ✓ 18 independent channels operating with up to 54 out of 100 pre-installed carrier frequencies between 5 kHz to 500 kHz. 3QPSK, 3BPSK, or 1BPSK modulation schemes with up to 18 levels of redundancy
 - ✓ Maximum raw data rates at Phy level between 1.22 Kbps to 7.32 Kbps depending modulation scheme
 - ✓ Scan Frequency tool to scan for best 18 carrier frequencies based on RSSI and Received Success Rate for up to 8 nodes
 - ✓ Noise Indicator tool to detect noise level for selected frequency channels
 - ✓ Debug tool to test success rate of communication links
 - ✓ Options for operation on CENELEC A, CENELEC B, CENELEC C, CENELEC D, FCC or ARIB bands.
 - ✓ Rx Sensitivity: -75 dBm
- **LoRa Radio Frequency:**
 - ✓ LoRa™ Modem



- ✓ 168 dB maximum link budget
- ✓ +18 dBm - 60 mW constant RF output vs. V supply
- ✓ +14 dBm high efficiency PA
- ✓ Data rate up to 2.4 kbps
- ✓ High sensitivity: down to -148 dBm
- ✓ Bullet-proof front end: IIP3 = -12.5 dBm
- ✓ Excellent blocking immunity
- ✓ Low RX current of 10.3 mA, 200 nA register retention
- ✓ Fully integrated synthesizer with a resolution of 61 Hz
- ✓ FSK, GFSK, MSK, GMSK, LoRa™ and OOK modulation
- ✓ Operating communication frequency- Sub 1GHz
- ✓ Built-in bit synchronizer for clock recovery
- ✓ Preamble detection
- ✓ 127 dB Dynamic Range RSSI
- ✓ Automatic RF Sense and CAD with ultra-fast AFC.
- ✓ Packet engine up to 256 bytes with CRC.

Contact Information

For more information regarding the GC9838 DIN Rail hybrid PLC-RF modem including pricing and ordering, please contact: gridComm Pte Ltd

sales@gridCommplc.com

www.gridComm-plc.com

Warning: Changes or modifications to this unit not expressly approved by the party responsible for compliance could void the user's authority to operate the equipment.

***This device complies with Part 15 of the FCC Rules. Operation is subject to the following two conditions:
(1) this device may not cause harmful interference and
(2) this device must accept any interference received including interference that may cause undesired operation.***

Dimensions of Hybrid PLC-RF DIN RAIL Modem

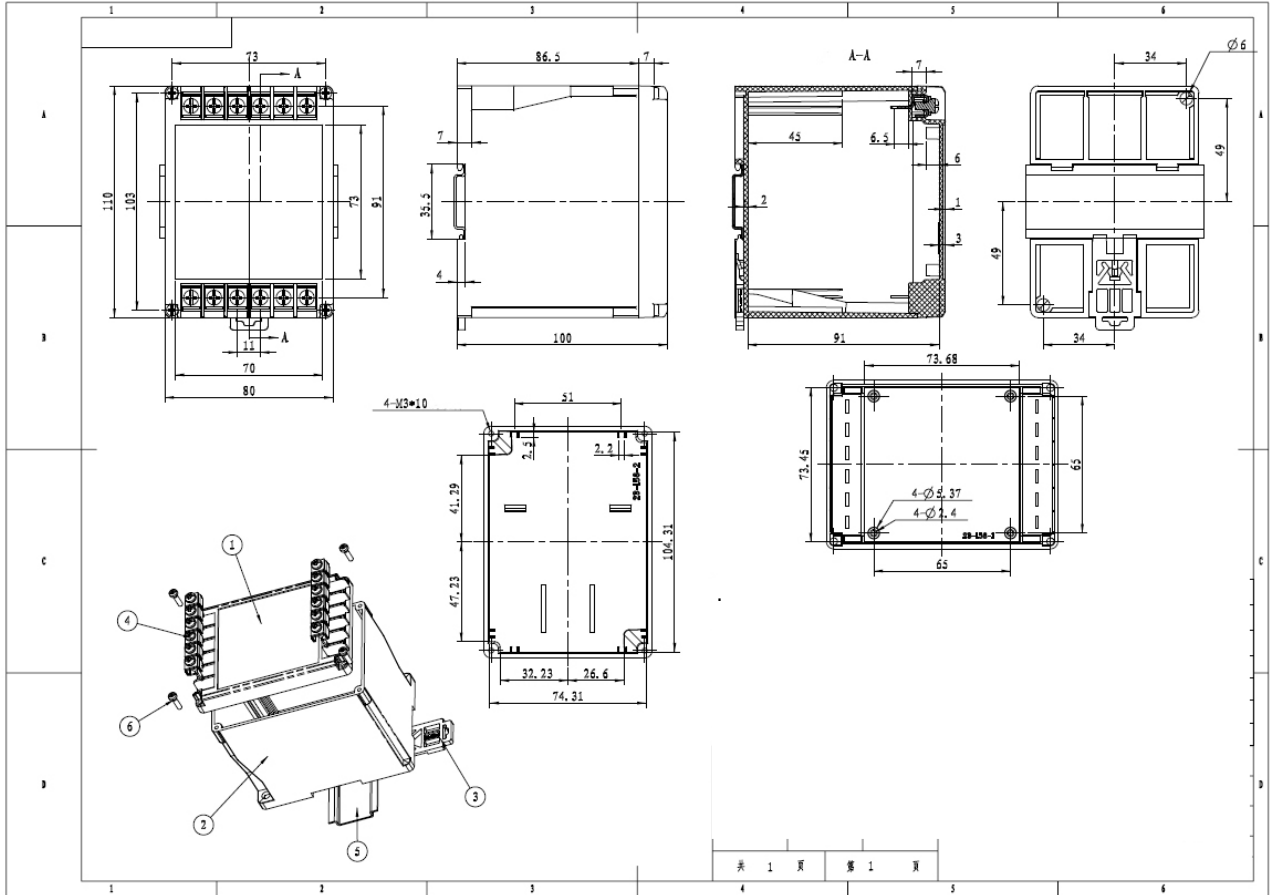

FCC Warning

This device complies with Part 15 of the FCC Rules. Operation is subject to the following two conditions

- (1) this device may not cause harmful interference, and
- (2) this device must accept any interference received, including interference that may cause undesired operation. Changes or modifications not expressly approved by the party responsible for compliance could void the user's authority to operate the equipment.

Note 1: This equipment has been tested and found to comply with the limits for a Class B digital device, pursuant to part 15 of the FCC Rules. These limits are designed to provide reasonable protection against harmful interference in a residential installation. This equipment generates, uses and can radiate radio frequency energy and, if not installed and used in accordance with the instructions, may cause harmful interference to radio communications. However, there is no guarantee that interference will not occur in a particular installation. If this equipment does cause harmful interference to radio or television reception, which can be determined by turning the equipment off and on, the user is encouraged to try to correct the interference by one or more of the following measures:

- Reorient or relocate the receiving antenna.
- Increase the separation between the equipment and receiver.
- Connect the equipment into an outlet on a circuit different from that to which the receiver is connected.
- Consult the dealer or an experienced radio/TV technician for help.

Note 2: 1.Changes or modifications to this unit not expressly approved by the party responsible for compliance could void the user's authority to operate the equipment.

2. The minimum separation generally be used is at least 20 cm.