



FCC Part 15C Test Report

FCC ID: 2ALW2-SKY

Product Name:	1080P Full-HD Digital Video Transmission System
Trademark:	N/A
Model Name :	DVL1-SKY
Prepared For :	WUXI R2TECK TECHNOLOGY CO., LTD
Address :	Room307, Building C, Ceti, Wuxi software park, 111 Linhu avenue, new district, Wuxi city, China
Prepared By :	Shenzhen BCTC Technology Co., Ltd.
Address :	No.101,Yousong Road,Longhua New District, Shenzhen,China
Test Date:	Apr. 21- Apr. 29, 2017
Date of Report :	Apr. 29, 2017
Report No.:	BCTC-FY170301496E



TABLE OF CONTENTS

	Page
Test Report Declaration	
1. TEST SUMMARY	5
2. GENERAL PRODUCT INFORMATION	6
2.1. Product Function	6
2.2. Description of Device (EUT).....	6
2.3. Test Supporting System	7
2.4. Independent Operation Modes.....	7
2.5. Test Sites	8
2.6. List of Test and Measurement Instruments	9
3. TEST SET-UP AND OPERATION MODES	10
3.1. Principle of Configuration Selection	10
3.2. Block Diagram of Test Set-up.....	10
3.3. Auxiliary Equipment.....	11
3.4. Countermeasures to Achieve EMC Compliance	11
4. EMISSION TEST RESULTS	12
4.1. Conducted Emission Measurement.....	12
4.2. Radiated Emission Measurement.....	16
5. BAND EDGE COMPLIANCE TEST	25
5.1. Limits	25
5.2. TEST PROCEDURE	25
5.3. Test Data	25
6. 26DB AND 99% BANDWIDTH TEST	28
6.1. Measurement Procedure.....	28
7. OUTPUT POWER TEST	31
7.1. Limits	31
7.2. Test setup	31
7.3. Test result	32
8. PEAK POWER SPECTRAL DENSITY TEST	33
8.1. Limits	33
8.2. Test setup	33
8.3. Test data.....	34
9. DUTY CYCLE TEST SIGNAL	36
10. FREQUENCY STABILITY	38
10.1. Limits	38
10.2. Test Procedures.....	38
10.3. Test Setup Layout.....	38
10.4. EUT Operation during Test.....	38
10.5. Test Results.....	39
11. TRANSMISSION IN THE ABSENCE OF DATA	41
11.1. Limits	41
11.2. Test result	41
12. ANTENNA REQUIREMENT	42
12.1. STANDARD REQUIREMENT	42
12.2. EUT ANTENNA.....	42



13.	PHOTOGRAPHS OF TEST SET-UP	43
14.	PHOTOGRAPHS OF THE EUT	45



1.TEST SUMMARY

Test Items	Test Requirement	Result
Conducted Emissions	RSS-GEN 15.207	PASS
Radiated Emissions	RSS-GEN 15.407(b), 15.209	PASS
26dB bandwidth and 99%dB Bandwidth	RSS-247 15.403(i) 15.407(e)	PASS
Power density	RSS-247 15.407 (a)	PASS
Maximum Peak Output Power	RSS-247 15.407 (a)	PASS
Emissions from out of band	RSS-247 15.407 (b)	PASS
Transmission in case of Absence of Information	RSS-247 15.407(c)	PASS
Frequency Stability	RSS-247 15.407(g)	PASS
Antenna Requirement	15.203	PASS

Note: N/A means not applicable.



2.GENERAL PRODUCT INFORMATION

2.1. Product Function

Refer to Technical Construction Form and User Manual.

2.2. Description of Device (EUT)

Product Name:	1080P Full-HD Digital Video Transmission System
Model No.:	DVL1-SKY
Trade Name:	N/A
Operation Frequency:	5200MHz
Channel numbers:	1Channel
Modulation technology:	DSSS
Antenna Type:	Permanent Connection External antenna*2
Antenna gain:	3.0dBi
Power supply:	DC 12V



Channel List			
Channel	Frequency (MHz)	Channel	Frequency (MHz)
1	5200	/	/

Ant.	Brand	Model Name	Antenna Type	Connector	Gain (dBi)	NOTE
1	N/A	N/A	Permanent Connection External antenna	N/A	3.0	
2	N/A	N/A	Permanent Connection External antenna	N/A	3.0	

Note1: Directional Gain=3.0dBi+10log(2)=6.01dBi

Note2: The EUT is support MIMO mode.

2.3. Test Supporting System

None.

2.4. Independent Operation Modes

The basic operation modes are:

These is Digital Transmission system and have modulation DQPSK. According exploratory test, EUT will have maximum output power in those data rate (6Mbps,), so those data rate were used for all test. The equipment enables high-speed access without wires to network assets.

Frequency
5200MHz



2.5. Test Sites

2.5.1. Test Facilities

Lab Qualifications : FCC Registration No.:187086
IC Registered No.:12655A



2.6. List of Test and Measurement Instruments

Radiation Test equipment

Item	Equipment	Manufacturer	Type No.	Serial No.	Last calibration	Calibrated until
1	Spectrum Analyzer (9kHz-26.5GHz)	Agilent	E4407B	MY45108040	2016.08.27	2017.08.26
2	Test Receiver (9kHz-7GHz)	R&S	ESPI	101318	2016.08.27	2017.08.26
3	Bilog Antenna (30MHz-1GHz)	R&S	VULB 9168	VULB91 68-438	2016.08.27	2017.08.26
4	Horn Antenna (1GHz-18GHz)	SCHWARZBECK	BBHA9120D	1201	2016.09.03	2017.09.03
5	Horn Antenna (14GHz-40GHz)	SCHWARZBECK	BBHA 9170	9170-181	2016.09.03	2017.09.03
6	Amplifier (9KHz-6GHz)	SCHWARZBECK	BBV9744	9744-0037	2016.08.27	2017.08.26
7	Amplifier (1GHz-18GHz)	SCHWARZBECK	BBV9718	9718-309	2016.08.27	2017.08.26
8	Amplifier (18GHz-40GHz)	SCHWARZBECK	BBV 9721	9721-205	2016.08.27	2017.08.26
9	Loop Antenna (9KHz-30MHz)	SCHWARZBECK	FMZB1519B	00014	2016.09.03	2017.09.03
10	RF cables1 (9kHz-1GHz)	R&S	R203	R20X	2016.08.27	2017.08.26
11	RF cables2 (1GHz-40GHz)	R&S	R204	R21X	2016.08.27	2017.08.26
12	Antenna connector	Florida RF Labs	N/A	RF 01#	2016.08.27	2017.08.26
13	Power Metter	ANRITSU	ML2487A	6K00001568	2016.08.27	2017.08.26
14	Power Sensor (AV)	ANRITSU	ML2491A	030989	2016.08.27	2017.08.26
15	Signal Analyzer 9kHz-26.5GHz	Agilent	N9010A	MY48030494	2016.08.27	2017.08.26
16	Test Receiver 20kHz-40GHz	R&S	ESU 40	100376	2016.08.27	2017.08.26
17	D.C. Power Supply	LongWei	PS-305D	010964729	2016.08.27	2017.08.26

Conduction Test equipment

Item	Equipment	Manufacturer	Type No.	Serial No.	Last calibration	Calibrated until
1	Test Receiver	R&S	ESCI	1166.5950K03-1011 65-ha	2016.08.27	2017.08.26
2	LISN	SCHWARZBECK	NSLK8127	8127739	2016.08.27	2017.08.26
3	LISN	R&S	NSLK8126	8126487	2016.08.27	2017.08.26
4	RF cables	R&S	R204	R20X	2016.08.27	2017.08.26
5	Attenuator	R&S	ESH3-Z2	143206	2016.08.27	2017.08.26

3. TEST SET-UP AND OPERATION MODES

3.1. Principle of Configuration Selection

Emission: The equipment under test (EUT) was configured to measure its highest possible radiation level. The test modes were adapted accordingly in reference to the Operating Instructions.

3.2. Block Diagram of Test Set-up

Radiated Spurious Emission Test

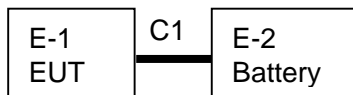

Conducted Emission Test

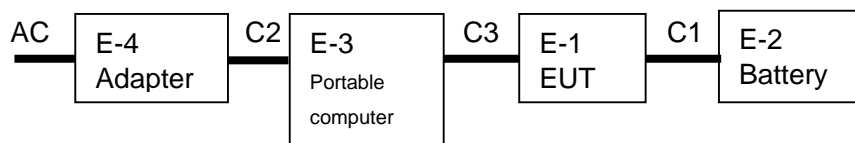

(EUT: 1080P Full-HD Digital Video Transmission System)



3.3. Auxiliary Equipment

Item	Equipment	Mfr/Brand	Model/Type No.	Series No.	Note
E-1	1080P Full-HD Digital Video Transmission System	N/A	Insight rx	N/A	EUT
E-2	Battery	CONSENT	GS12V7AH	N/A	Peripheral
E-3	Portable computer	N/A	X550C	N/A	Peripheral
E-4	Adapter	N/A	AD887520	N/A	Peripheral

Item	Shielded Type	Ferrite Core	Length	Note
C1	No	No	0.5m	DC cable unshielded
C2	No	No	1.5m	DC cable unshielded
C3	No	No	0.8m	HDMI cable shielded

3.4. Countermeasures to Achieve EMC Compliance

None.



4. EMISSION TEST RESULTS

4.1. Conducted Emission Measurement

POWER LINE CONDUCTED EMISSION Limits (Frequency Range 150KHz-30MHz)

FREQUENCY (MHz)	Limit (dBuV)		Standard
	Quasi -peak	Average	
0.15 -0.5	66 - 56 *	56 - 46 *	FCC
0.50 -5.0	56.00	46.00	FCC
5.0 -30.0	60.00	50.00	FCC

Note:

- (1) The tighter limit applies at the band edges.
- (2) The limit of " * " marked band means the limitation decreases linearly with the logarithm of the frequency in the range.

The following table is the setting of the receiver

Receiver Parameters	Setting
Attenuation	10 dB
Start Frequency	0.15 MHz
Stop Frequency	30 MHz
IF Bandwidth	9 kHz

4.1.1. TEST PROCEDURE

- a. The EUT was placed 0.8 meters from the horizontal ground plane with EUT being connected to the power mains through a line impedance stabilization network (LISN). All other support equipments powered from additional LISN(s). The LISN provide 50 Ohm/ 50uH of coupling impedance for the measuring instrument.
- b. Interconnecting cables that hang closer than 40 cm to the ground plane shall be folded back and forth in the center forming a bundle 30 to 40 cm long.
- c. I/O cables that are not connected to a peripheral shall be bundled in the center. The end of the cable may be terminated, if required, using the correct terminating impedance. The overall length shall not exceed 1 m.
- d. LISN at least 80 cm from nearest part of EUT chassis.
- e. For the actual test configuration, please refer to the related Item –EUT Test Photos.

4.1.2. DEVIATION FROM TEST STANDARD

No deviation

4.1.3. TEST SETUP

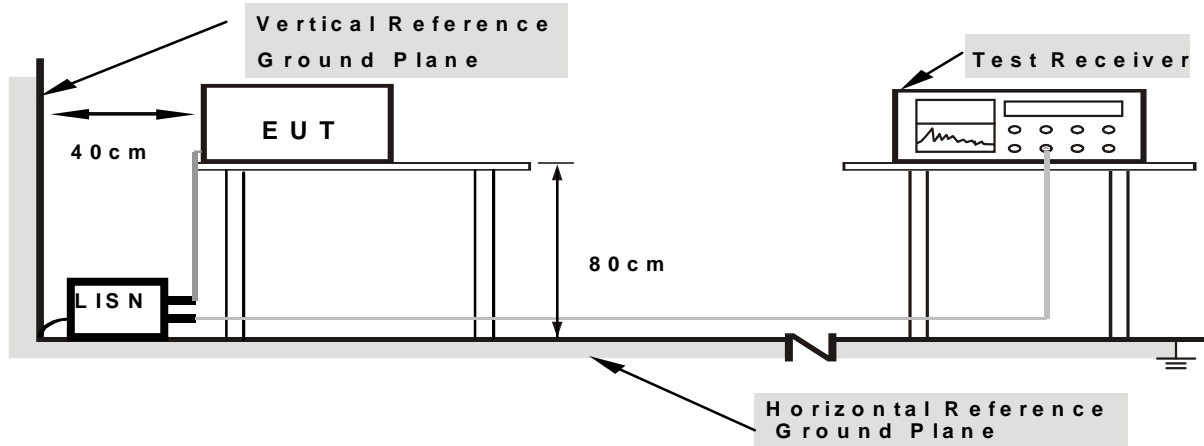

- Note: 1.Support units were connected to second LISN .
2.Both of LISNs (AMN) are 80 cm from EUT and at least 80 cm from other units and other metal planes

4.1.4. EUT OPERATING CONDITIONS

The EUT was configured for testing in a typical fashion (as a customer would normally use it). The EUT has been programmed to continuously transmit during test. This operating condition was tested and used to collect the included data.

We pretest all adapter's emission, only the adapter 1's data was worst and the data was recording in the report.

The data only show the worst mode.

If peak level comply with Quasi-Peak limit, then the Quasi-Peak level is deemed to comply with Quasi-Peak limit.

We pretest AC 120V and AC 240V, the worst voltage was AC 120V and the data recording in the report

4.1.5. TEST RESULTS



Temperature:	25 °C	Relative Humidity:	54%
Pressure:	1010hPa	Phase :	L
Test Voltage :	AC 120V/60Hz	Test Mode:	Link

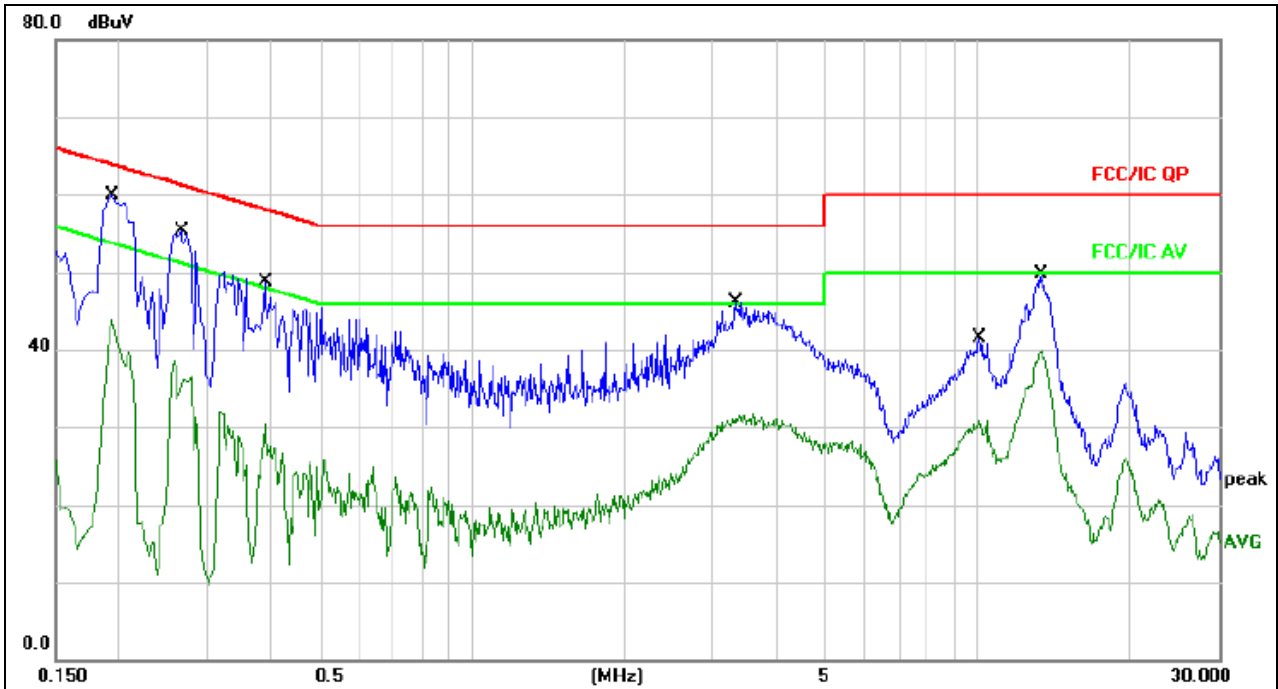

Remark:

1. All readings are Quasi-Peak and Average values.
2. Factor = Insertion Loss + Cable Loss.

No.	Mk.	Freq. MHz	Reading Level dBuV	Correct Factor dB	Measure- ment dBuV	Limit dBuV	Over dB	Detector	Comment
1	*	0.1940	50.29	9.65	59.94	63.86	-3.92	QP	
2		0.1940	34.26	9.65	43.91	53.86	-9.95	AVG	
3		0.2660	45.57	9.66	55.23	61.24	-6.01	QP	
4		0.2660	28.87	9.66	38.53	51.24	-12.71	AVG	
5		0.3899	39.04	9.67	48.71	58.06	-9.35	QP	
6		0.3899	20.76	9.67	30.43	48.06	-17.63	AVG	
7		3.3220	36.40	9.72	46.12	56.00	-9.88	QP	
8		3.3220	21.85	9.72	31.57	46.00	-14.43	AVG	
9		10.1100	31.59	9.83	41.42	60.00	-18.58	QP	
10		10.1100	21.10	9.83	30.93	50.00	-19.07	AVG	
11		13.3900	39.83	9.84	49.67	60.00	-10.33	QP	
12		13.3900	29.96	9.84	39.80	50.00	-10.20	AVG	



Temperature:	25 °C	Relative Humidity:	54%
Pressure:	1010hPa	Phase :	N
Test Voltage :	AC 120V/60Hz	Test Mode:	Link

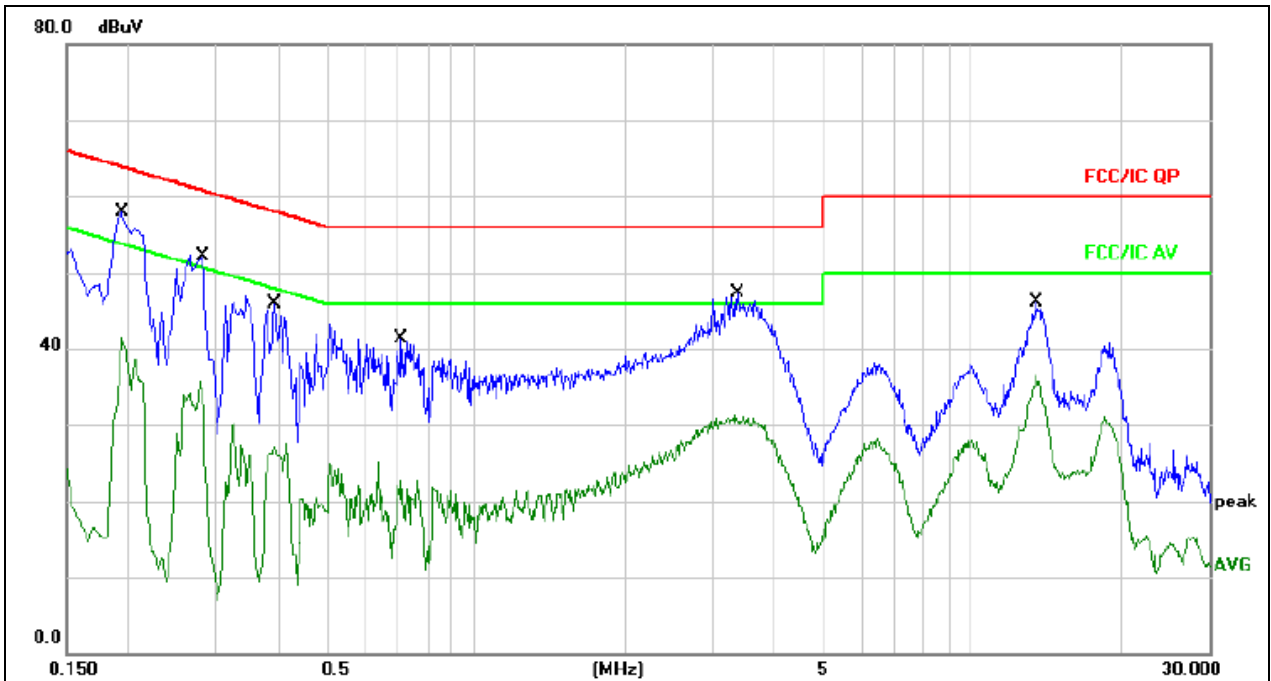

Remark:

1. All readings are Quasi-Peak and Average values.
2. Factor = Insertion Loss + Cable Loss.

No.	Mk.	Freq. MHz	Reading Level dBuV	Correct Factor dB	Measure- ment dBuV	Limit dBuV	Over dB	Detector	Comment
1	*	0.1940	48.20	9.65	57.85	63.86	-6.01	QP	
2		0.1940	31.82	9.65	41.47	53.86	-12.39	AVG	
3		0.2819	42.42	9.66	52.08	60.76	-8.68	QP	
4		0.2819	25.96	9.66	35.62	50.76	-15.14	AVG	
5		0.3940	36.32	9.67	45.99	57.98	-11.99	QP	
6		0.3940	17.76	9.67	27.43	47.98	-20.55	AVG	
7		0.7100	31.72	9.68	41.40	56.00	-14.60	QP	
8		0.7100	13.06	9.68	22.74	46.00	-23.26	AVG	
9		3.3740	37.51	9.72	47.23	56.00	-8.77	QP	
10		3.3740	21.52	9.72	31.24	46.00	-14.76	AVG	
11		13.5060	36.33	9.84	46.17	60.00	-13.83	QP	
12		13.5060	26.57	9.84	36.41	50.00	-13.59	AVG	



4.2. Radiated Emission Measurement

4.2.1. Radiated Emission Limits (Frequency Range 9kHz-1000MHz)

20dBc in any 100 kHz bandwidth outside the operating frequency band. In case the emission fall within the restricted band specified on 15.205(a), then the 15.209(a) limit in the table below has to be followed.

Frequencies (MHz)	Field Strength (micorvolts/meter)	Measurement Distance (meters)
0.009~0.490	2400/F(KHz)	300
0.490~1.705	24000/F(KHz)	30
1.705~30.0	30	30
30~88	100	3
88~216	150	3
216~960	200	3
Above 960	500	3

LIMITS OF RADIATED EMISSION MEASUREMENT (Above 1000MHz)

FREQUENCY (MHz)	Limit (dBuV/m) (at 3M)	
	PEAK	AVERAGE
Above 1000	74	54

Notes:

- (1) The limit for radiated test was performed according to FCC PART 15C.
- (2) The tighter limit applies at the band edges.
- (3) Emission level (dBuV/m)=20log Emission level (uV/m).

FREQUENCY RANGE OF RADIATED MEASUREMENT (For unintentional radiators)

Highest frequency generated or Upper frequency of measurement used in the device or on which the device operates or tunes (MHz)	Range (MHz)
Below 1.705	30
1.705 – 108	1000
108 – 500	2000
500 – 1000	5000
Above 1000	5th harmonic of the highest frequency or 40 GHz, whichever is lower



Spectrum Parameter	Setting
Attenuation	Auto
Start Frequency	1000 MHz
Stop Frequency	10th carrier harmonic
RB / VB (emission in restricted band)	1 MHz / 1 MHz for Peak, 1 MHz / 10Hz for Average

Receiver Parameter	Setting
Attenuation	Auto
Start ~ Stop Frequency	9kHz~150kHz / RB 200Hz for QP
Start ~ Stop Frequency	150kHz~30MHz / RB 9kHz for QP
Start ~ Stop Frequency	30MHz~1000MHz / RB 120kHz for QP

4.2.2. TEST PROCEDURE

- The EUT was placed on the top of a rotating table 0.8 meters above the ground at a 3 meter semi-anechoic chamber. The table was rotated 360 degrees to determine the position of the highest radiation.
- The EUT was set 3 meters away from the interference-receiving antenna, which was mounted on the top of a variable-height antenna tower.
- The antenna height is varied from one meter to four meters above the ground to determine the maximum value of the field strength. Both horizontal and vertical polarizations of the antenna are set to make the measurement.
- For each suspected emission, the EUT was arranged to its worst case and then the antenna was tuned to heights from 1 meter to 4 meters (for the test frequency of below 30MHz, the antenna was tuned to heights 1 meter) and the rotatable table was turned from 0 degrees to 360 degrees to find the maximum reading.
- The test-receiver system was set to Peak Detect Function and Specified Bandwidth with Maximum Hold Mode.
- If the emission level of the EUT in peak mode was 10dB lower than the limit specified, then testing could be stopped and the peak values of the EUT would be reported. Otherwise the emissions that did not have 10dB margin would be re-tested one by one using peak, quasi-peak or average method as specified and then reported in a data sheet.

Above 1GHz test procedure as below:

- Different between above is the test site, change from Semi- Anechoic Chamber to fully Anechoic Chamber and change form table 0.8 meter to 1.5 meter.
- Test the EUT in the lowest channel ,the middle channel ,the Highest channel

Note:

Both horizontal and vertical antenna polarities were tested and performed pretest to three orthogonal axis. The worst case emissions were reported

4.2.3. DEVIATION FROM TEST STANDARD

No deviation

4.2.4. TEST SETUP

(A) Radiated Emission Test-Up Frequency Below 30MHz

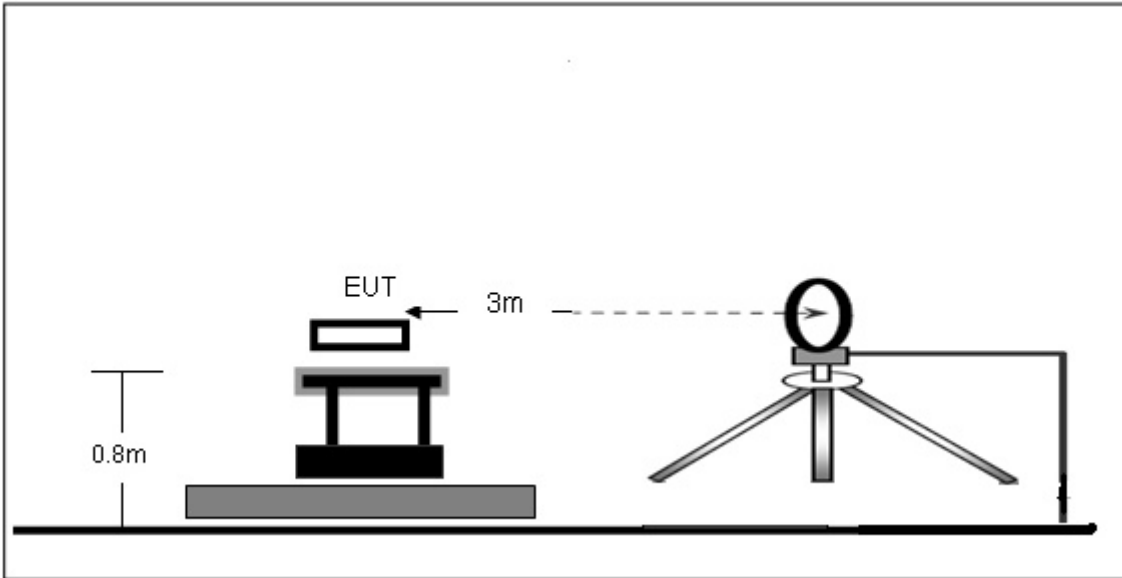

(B) Radiated Emission Test-Up Frequency 30MHz~1GHz

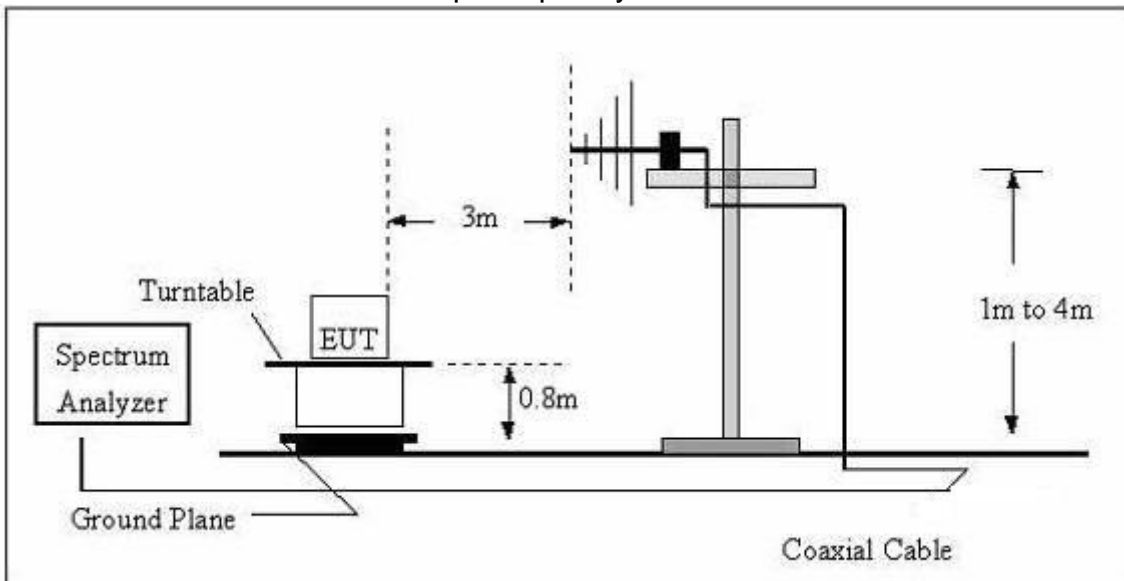

(C) Radiated Emission Test-Up Frequency Above 1GHz

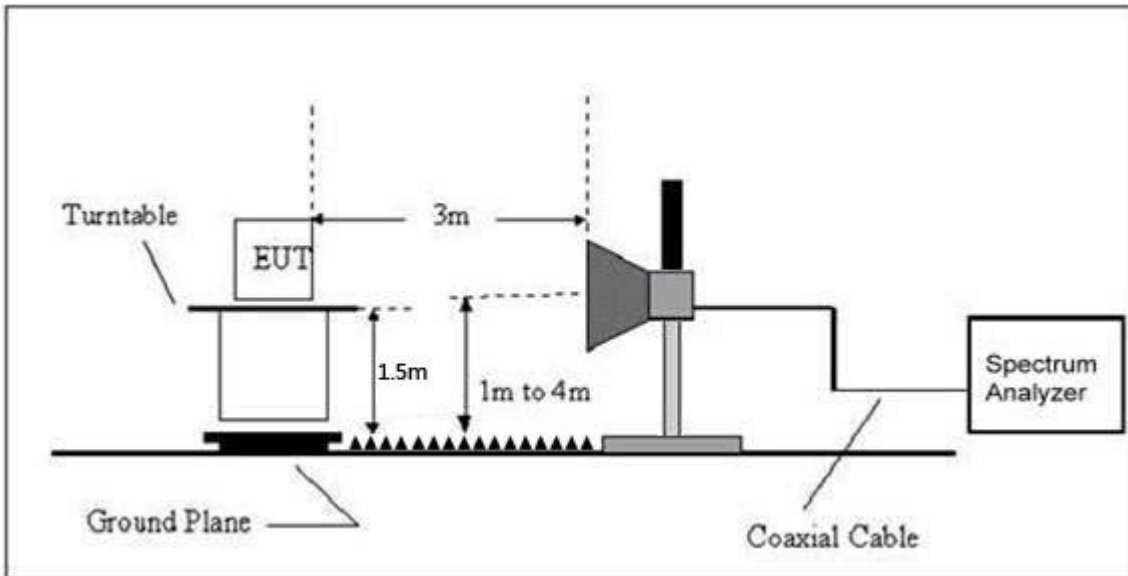

4.2.5. EUT OPERATING CONDITIONS

The EUT tested system was configured as the statements of 2.4 Unless otherwise a special operating condition is specified in the follows during the testing.

We pretest all adapter's emission, only the adapter 1's data was worst and the data was recording in the report.

The data only show the worst mode.



Radiated Spurious Emission (Below 30MHz)

EUT :	1080P Full-HD Digital Video Transmission System	Model Name :	Insight rx
Temperature :	20 °C	Relative Humidity :	48%
Pressure :	1010 hPa	Polarization :	---
Test Voltage :	DC 12V		
Test Mode :	TX		

Freq. (MHz)	Reading (dBuV/m)	Limit (dBuV/m)	Margin (dB)	State P/F
--	--	--	--	PASS
--	--	--	--	PASS

Note:

The amplitude of spurious emissions which are attenuated by more than 20dB below the permissible value has no need to be reported.

Distance extrapolation factor = $40 \log (\text{specific distance}/\text{test distance})$ (dB);

Limit line = specific limits(dBuv) + distance extrapolation factor.



Radiated Spurious Emission (Between 30MHz – 1GHz)

Temperature :	26 °C	Relative Humidity :	54%
Pressure :	1010 hPa	Polarization :	Horizontal
Test Voltage :	DC 12V		
Test Mode : (Worst)	Link Mode		

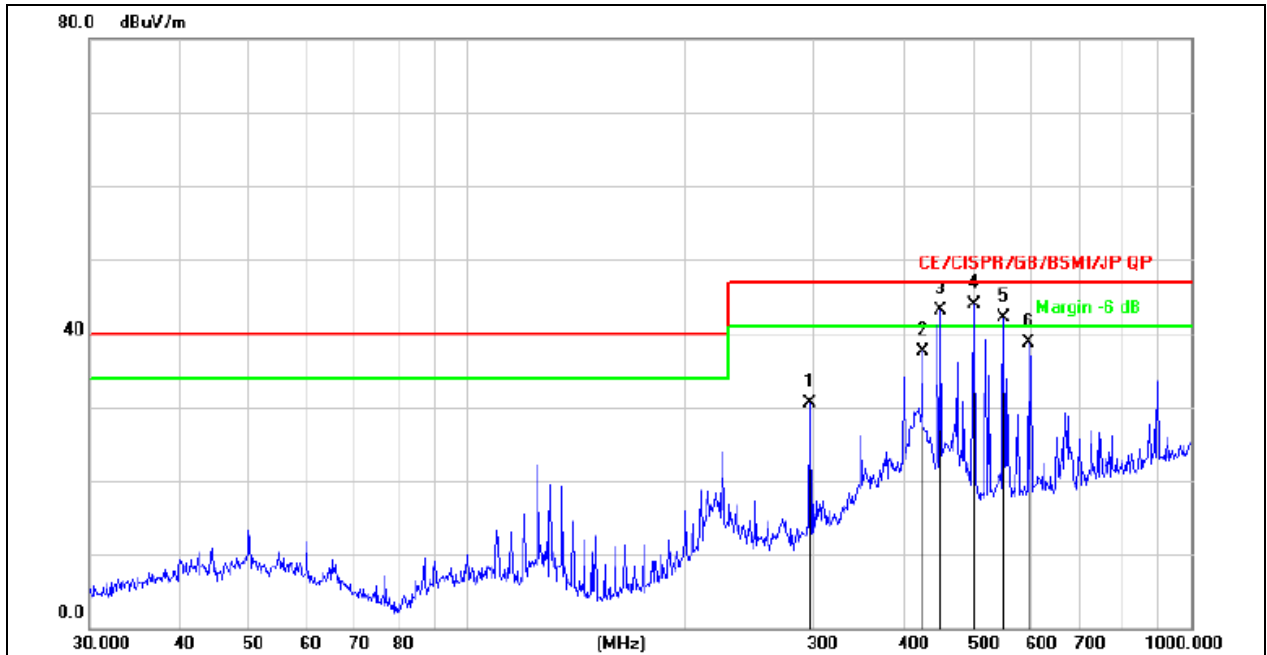

Remark:
Factor = Antenna Factor + Cable Loss – Pre-amplifier.

No.	Mk.	Freq. MHz	Reading Level dBuV	Correct Factor dB	Measure- ment dBuV/m	Limit dB/m	Over dB	Detector
1		297.2241	42.70	-12.16	30.54	47.00	-16.46	QP
2		425.0280	46.30	-8.74	37.56	47.00	-9.44	QP
3	!	451.1349	51.48	-8.42	43.06	47.00	-3.94	QP
4	*	501.1789	51.06	-7.16	43.90	47.00	-3.10	QP
5	!	550.9479	48.12	-6.06	42.06	47.00	-4.94	QP
6		595.1327	43.36	-4.65	38.71	47.00	-8.29	QP



Temperature :	26 °C	Relative Humidity :	54%
Pressure :	1010 hPa	Polarization :	Vertical
Test Voltage :	DC 12V		
Test Mode : (Worst)	Link Mode		

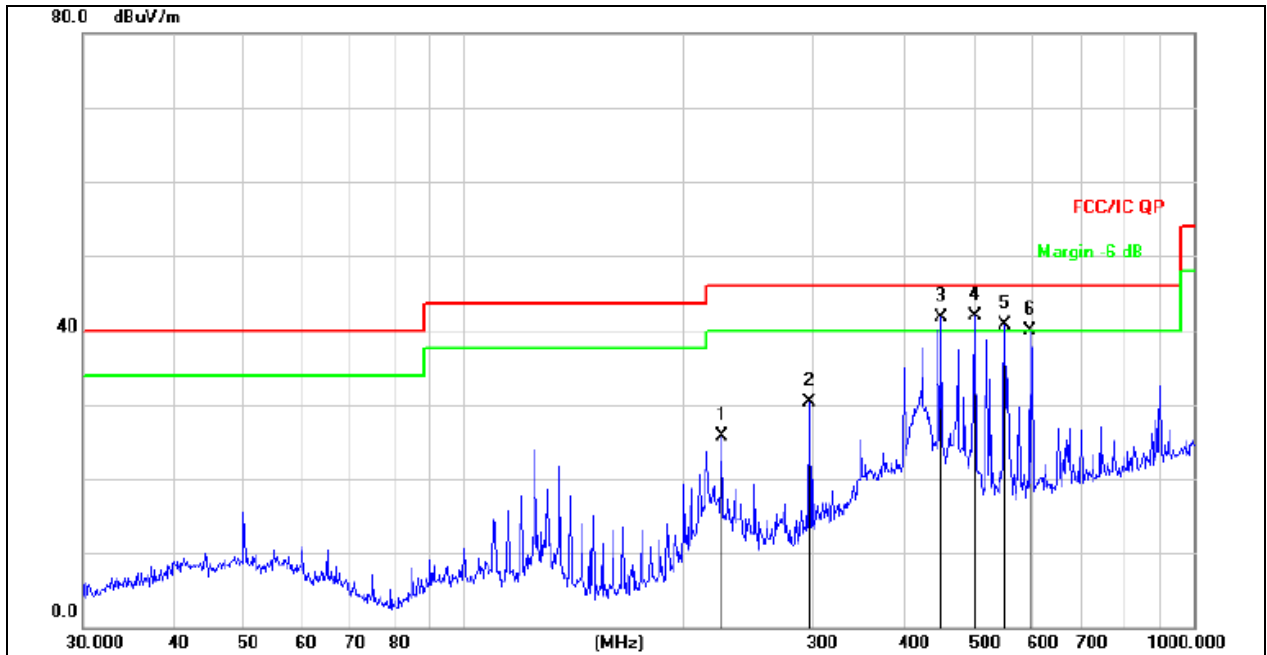

Remark:
Factor = Antenna Factor + Cable Loss – Pre-amplifier.

No.	Mk.	Freq. MHz	Reading Level dBuV	Correct Factor dB	Measure- ment dBuV/m	Limit dB/m	Over dB	Detector
1		225.3079	40.61	-14.93	25.68	46.00	-20.32	QP
2		297.2241	42.39	-12.16	30.23	46.00	-15.77	QP
3	!	451.1349	50.11	-8.42	41.69	46.00	-4.31	QP
4	*	501.1789	49.14	-7.16	41.98	46.00	-4.02	QP
5	!	550.9479	46.78	-6.06	40.72	46.00	-5.28	QP
6		595.1327	44.54	-4.65	39.89	46.00	-6.11	QP



Radiated Spurious Emission (Above 1GHz)

	Freq.	Receiver Reading	Detector	Polar	Pre-amplifier	Cable Loss	Antenna Factor	Emission Level	Limit	Result
	(MHz)	(dBμV)	(PK/QP/Ave)	(H/V)	(dB)	(dB)	(dB)	(dBμV/m)	(dBμV/m)	
5200MHz	10400.00	55.98	PK	H	36.38	10.20	27.10	56.9	74.00	Pass
	10400.00	46.47	PK	H	36.38	10.20	27.10	47.39	54.00	Pass
	15600.00	55.75	PK	H	36.45	10.55	27.50	57.35	74.00	Pass
	15600.00	44.86	PK	H	36.45	10.55	27.50	46.46	54.00	Pass
	10400.00	56.57	PK	V	36.68	10.20	27.10	57.19	74.00	Pass
	10400.00	45.79	PK	V	36.68	10.20	27.10	46.41	54.00	Pass
	15600.00	56.23	PK	V	36.50	10.55	27.50	57.78	74.00	Pass
	15600.00	45.97	PK	V	36.50	10.55	27.50	47.52	54.00	Pass

Remark:

Emission Level = Receiver Reading + Antenna Factor + Cable Loss – Pre-amplifier.

Margin = Emission Level - Limit

Other harmonics emissions are lower than 20dB below the allowable limit.

18G~40GHz

	Freq.	Receiver Reading	Detector	Polar	Pre-amplifier	Cable Loss	Antenna Factor	Emission Level	Limit	Result
	(MHz)	(dBμV)	(PK/QP/Ave)	(H/V)	(dB)	(dB)	(dB)	(dBμV/m)	(dBμV/m)	
5200MHz	20800.00	44.56	PK	H	37.15	10.55	28.12	46.08	74.00	Pass
	26000.00	43.56	PK	H	37.15	10.82	28.42	45.65	74.00	Pass
	31200.00	42.62	PK	H	37.68	11.18	28.78	44.90	74.00	Pass
	20800.00	42.76	PK	V	37.15	10.55	28.12	44.28	74.00	Pass
	26000.00	43.24	PK	V	37.15	10.82	28.42	45.33	74.00	Pass
	31200.00	43.62	PK	V	37.68	11.18	28.78	45.90	74.00	Pass

Remark:

Emission Level = Receiver Reading + Antenna Factor + Cable Loss – Pre-amplifier.

Margin = Emission Level - Limit

Other harmonics emissions are lower than 20dB below the allowable limit.

If the PK measured levels comply with average limit, then the average level were deemed to comply with average limit.



5200MHz Horizontal

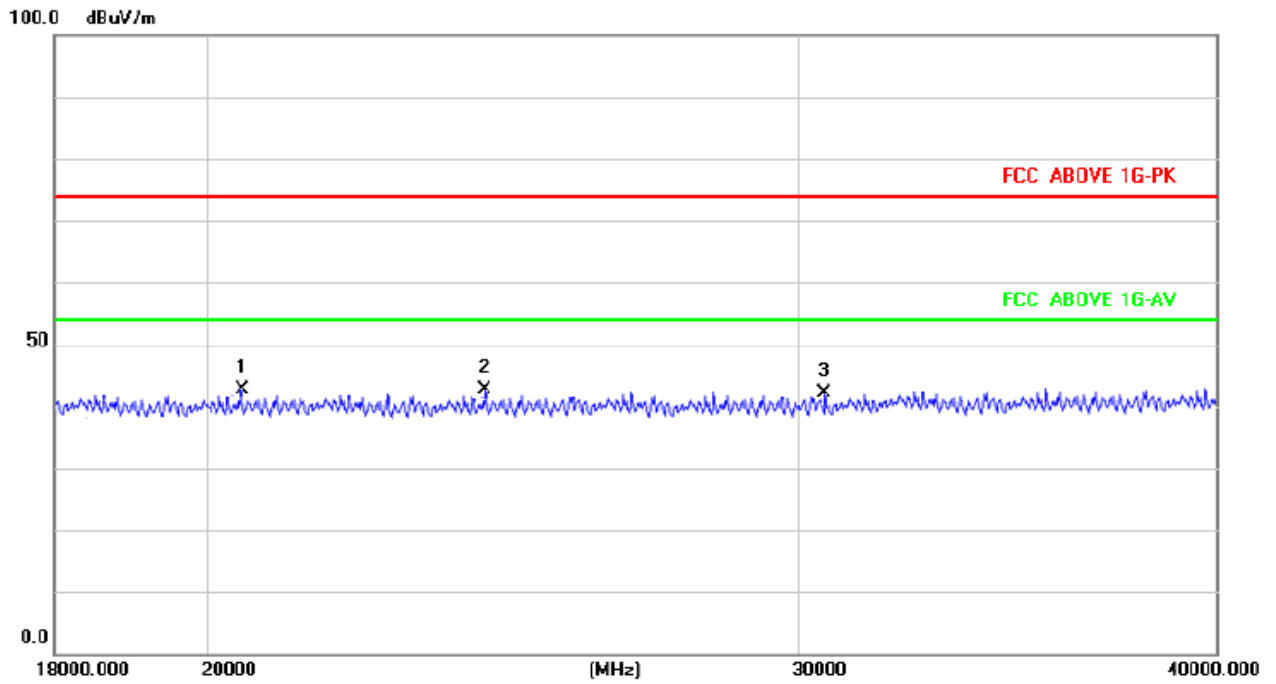

5200MHz Vertical

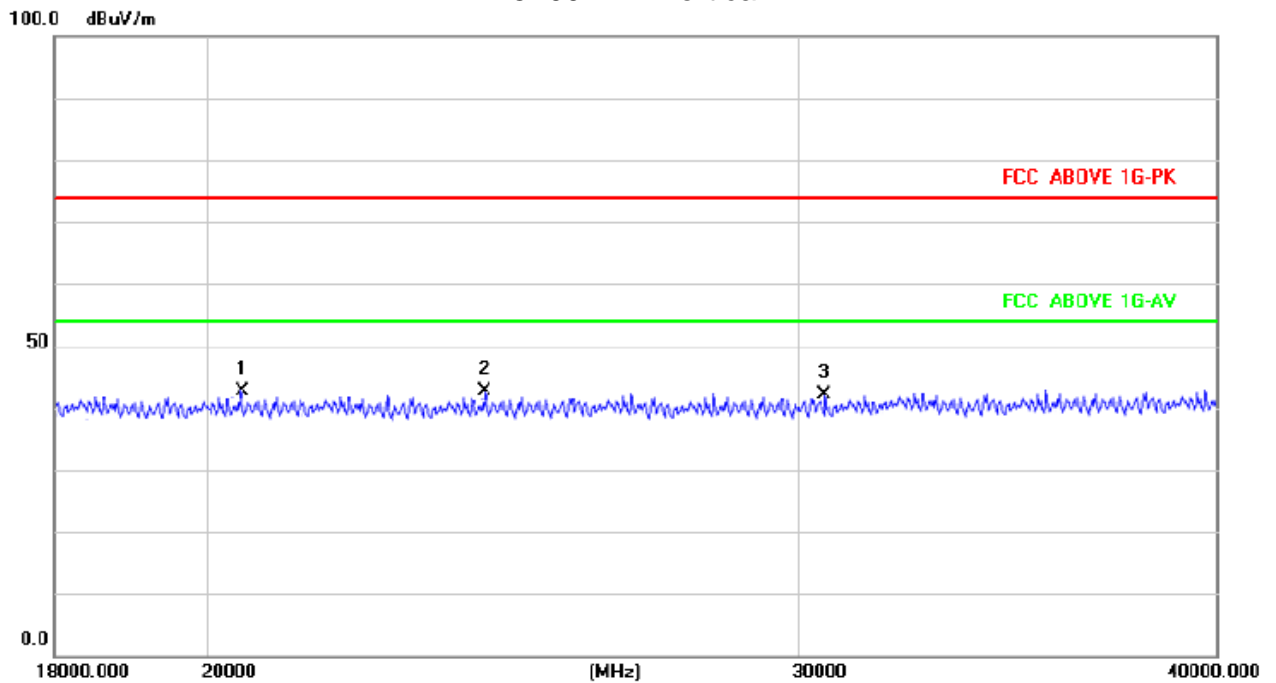



5. BAND EDGE COMPLIANCE TEST

5.1. Limits

(1) For transmitters operating in the 5.15-5.25 GHz band: All emissions outside of the 5.15-5.35 GHz band shall not exceed an e.i.r.p. of -27 dBm/MHz.

(4) For transmitters operating in the 5.725-5.85 GHz band: All emissions shall be limited to a level of -27 dBm/MHz at 75 MHz or more above or below the band edge increasing linearly to 10 dBm/MHz at 25 MHz above or below the band edge, and from 25 MHz above or below the band edge increasing linearly to a level of 15.6 dBm/MHz at 5 MHz above or below the band edge, and from 5 MHz above or below the band edge increasing linearly to a level of 27 dBm/MHz at the band edge.

5.2. TEST PROCEDURE

1. Check the calibration of the measuring instrument using either an internal calibrator or a known signal from an external generator.
2. Position the EUT without connection to measurement instrument. Turn on the EUT and connect its antenna terminal to measurement instrument via a low loss cable. Then set it to any one measured frequency within its operating range, and make sure the instrument is operated in its linear range.
3. Set RBW of spectrum analyzer to 1 MHz with a convenient frequency span.
4. Measure the highest amplitude appearing on spectral display and set it as a reference level. Plot the graph with marking the highest point and edge frequency.
5. Repeat above procedures until all measured frequencies were complete.

5.3. Test Data

Please see data as below:



Ant1

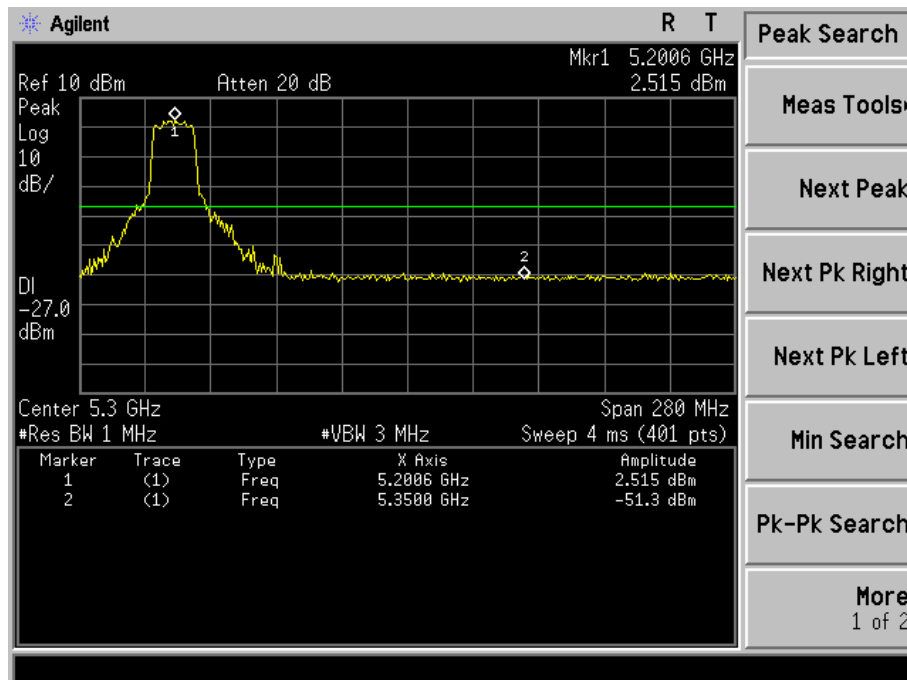
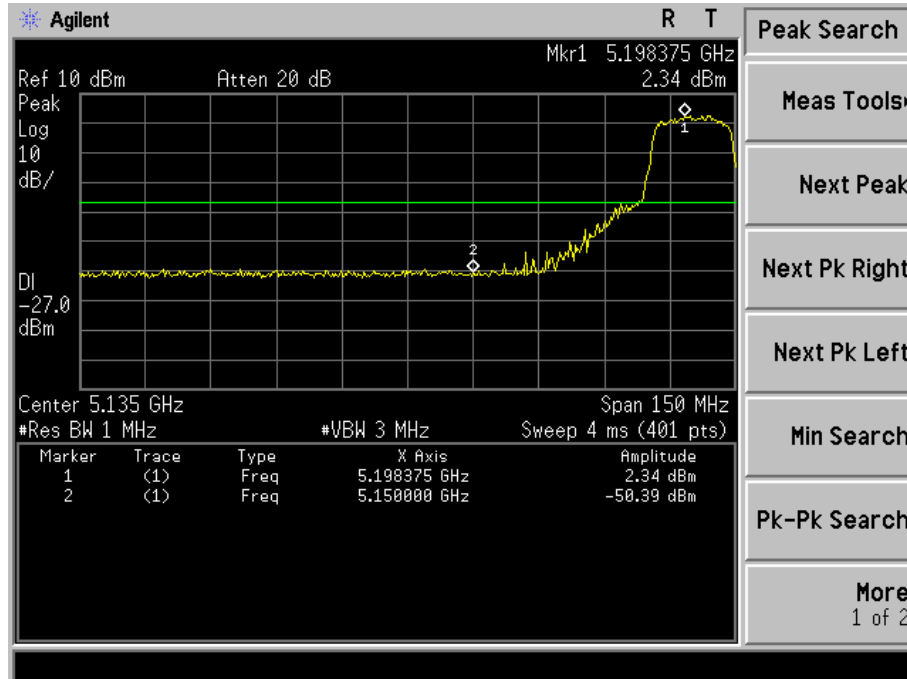



Ant2

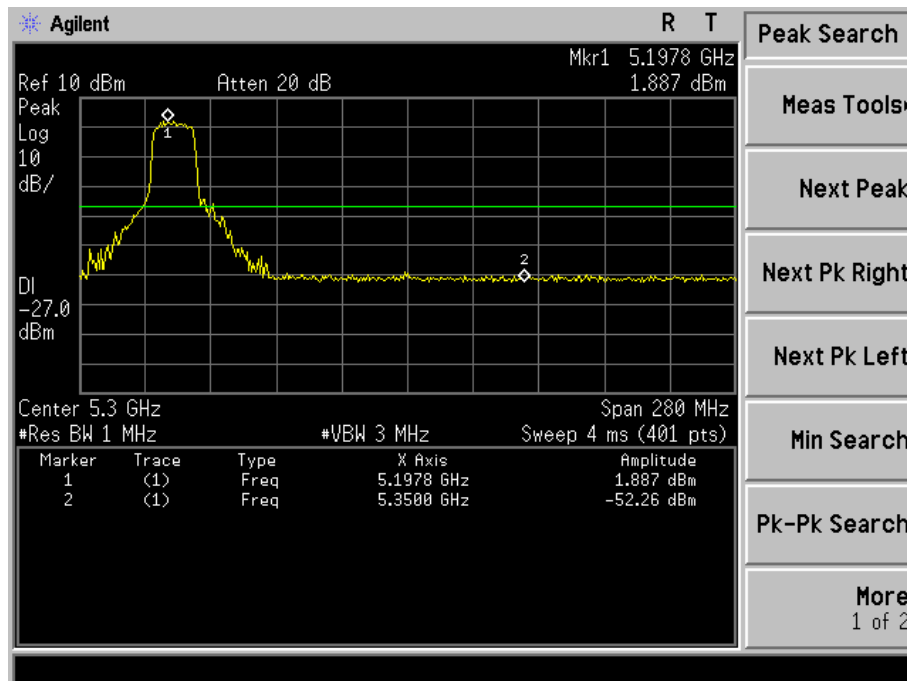
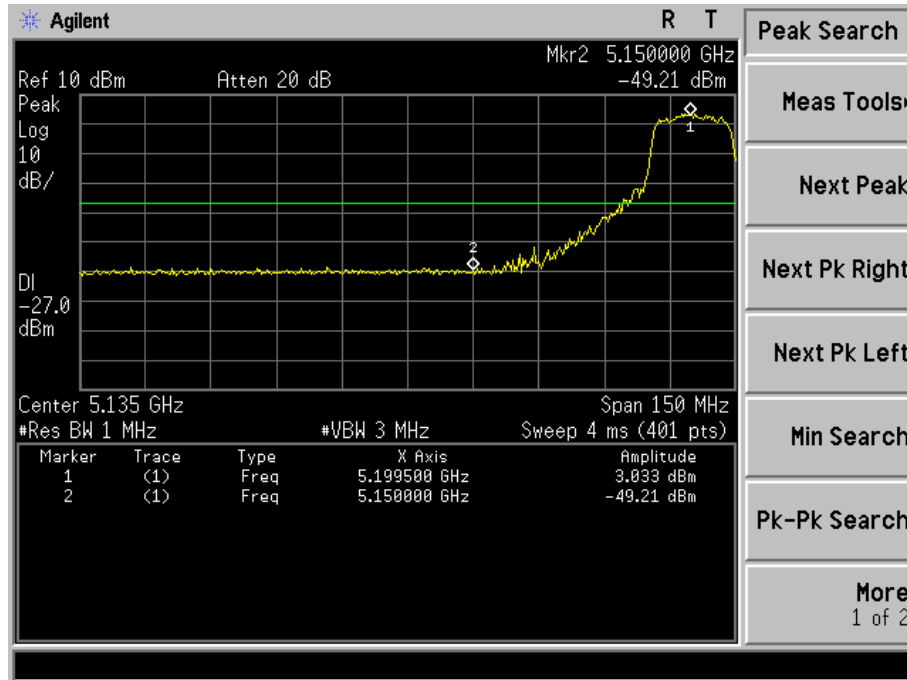



6. 26DB AND 99% BANDWIDTH TEST

6.1. Measurement Procedure

The bandwidth at 26 dB down from the highest in-band spectral density is measured with a spectrum analyzer connected to the antenna terminal while the EUT is operating at its maximum power control level, as defined in KDB 789033, at the appropriate frequencies. The spectrum analyzer's bandwidth measurement function is configured to measure the 26 dB bandwidth.

The 26 dB bandwidth is used to determine the conducted power limits.

There is no limit bandwidth for U-NII-1, U-NII-2-A and U-NII-2-C.

The minimum of 6dB Bandwidth measurement is 0.5 MHz for U-NII-3



26dB bandwidth

Frequency (MHz)	26dB Bandwidth (MHz)		99% Bandwidth (MHz)	
	Ant 1	Ant 2	Ant 1	Ant 2
5200	20.024	19.910	17.587	17.531



Ant 1

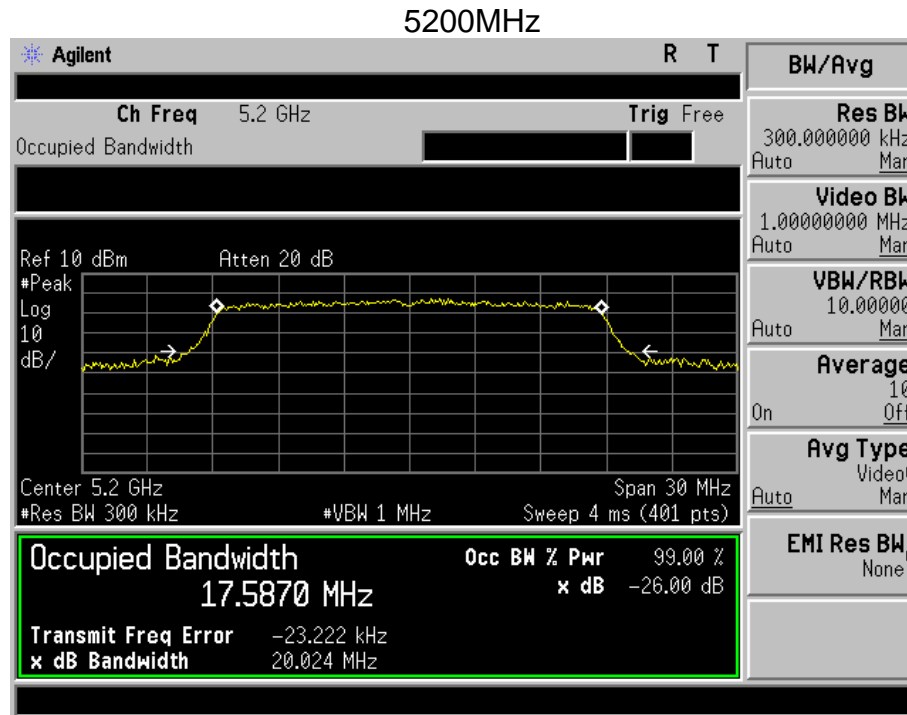

Ant 2

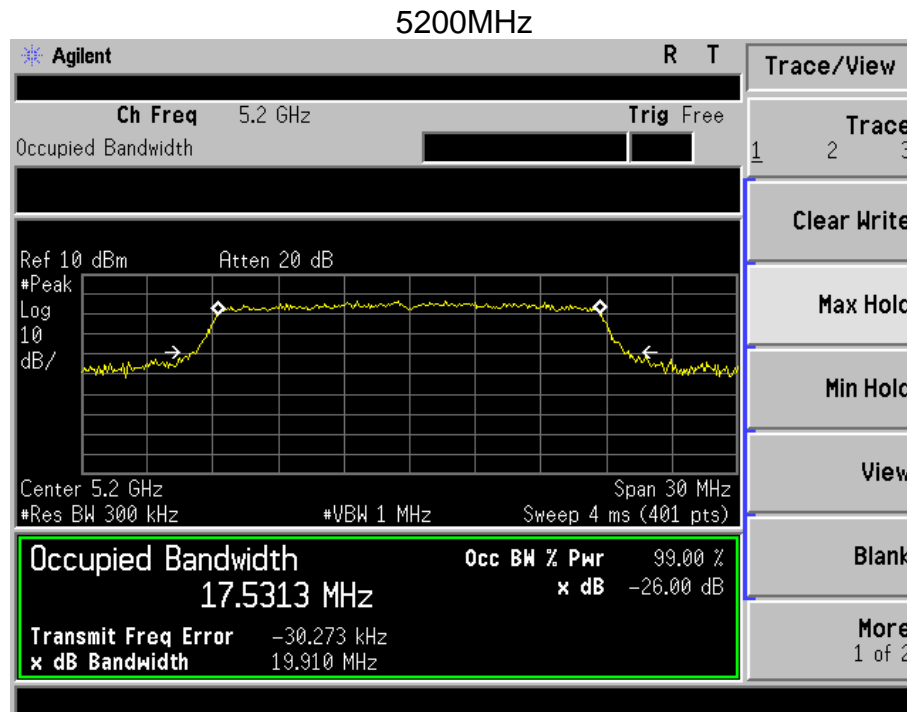



7. OUTPUT POWER TEST

7.1. Limits

For mobile and portable client devices in the 5.15-5.25 GHz band, the maximum conducted output power over the frequency band of operation shall not exceed 250 mW provided the maximum antenna gain does not exceed 6 dBi.

For the band 5.725-5.85 GHz, the maximum conducted output power over the frequency band of operation shall not exceed 1 W.

7.2. Test setup

1. The maximum average conducted output power can be measured using Method PM-G (Measurement using a gated RF average power meter):
2. Measurements may be performed using a wideband gated RF power meter provided that the gate parameters are adjusted such that the power is measured only when the EUT is transmitting at its maximum power control level. Since the measurement is made only during the ON time of the transmitter, no duty cycle correction factor is required.
 - a. The Transmitter output (antenna port) was connected to the power meter.
 - b. Turn on the EUT and power meter and then record the power value.
 - c. Repeat above procedures on all channels needed to be tested.
3. Note: the Directional Gain= $3\text{dBi}+10\log(2)=6.01\text{dBi}$, so the final limit=requirement limit-(6.01-6)



7.3. Test result

Frequency	Antenna port	Maximum Conducted Output Power(PK)	Maximum Conducted Output Power(PK)	Total Conducted Output Power(PK)	Total Conducted Output Power(PK)	LIMIT
(MHz)		(dBm)	(mW)	(mW)	(dBm)	dBm
5200	Ant.1	14.65	29.17	55.53	17.45	30
	Ant.2	14.21	26.36			



8. PEAK POWER SPECTRAL DENSITY TEST

8.1. Limits

In addition, the maximum power spectral density shall not exceed 11 dBm in any 1 megahertz band.

In addition, the maximum power spectral density shall not exceed 30 dBm in any 500 kHz band.

8.2. Test setup

1. Place the EUT on the table and set it in transmitting mode.
2. The testing follows FCC KDB 789033 D02.
3. Remove the antenna from the EUT and then connect a low loss RF cable from the antenna port to

Spectrum.

4. For U-NII1, U-NII-2A, U-NII-2C Band:

Set RBW=1MHz, VBW=3MHz, where span is enough to capture the entire bandwidth, Sweep time = Auto (601 pts), detector = sample, traces 100 sweeps of video averaging. (SA-2 with the omission of procedure x, the integration with 26dB EBW bandwidth)

For U-NII-3 Band:

Set RBW=510 kHz, VBW=3*RBW, where span is enough to capture the entire bandwidth, Sweep time = Auto (601 pts), detector = sample, traces 100 sweeps of video averaging. (SA-2 with the omission of procedure x, the integration with 26dB EBW bandwidth)

5. Use the cursor on spectrum to peak search the highest level of trace

6. Record the max. reading and add $10 \log(1/\text{duty cycle})$.

7. the Directional Gain= $3\text{dBi}+10\log(2)=6.01\text{dBi}$, so the final limit=requirement limit-(6.01-6)

we test all antennas, the antenna 1 was worst mode and the data recording in the report.



8.3. Test data

Test data as below

Frequency	Antenna port	Maximum Conducted Output Power(PK)	Duty factor	Duty factor 10 log (1MHz/RBW)	Total PPSD	LIMIT
(MHz)		(dBm)	(dB)		(dBm)	dBm
5200	Ant.1	3.153	0.0	0.0	5.87	11
	Ant.2	2.539	0.0	0.0		



Ant.1 5200MHz

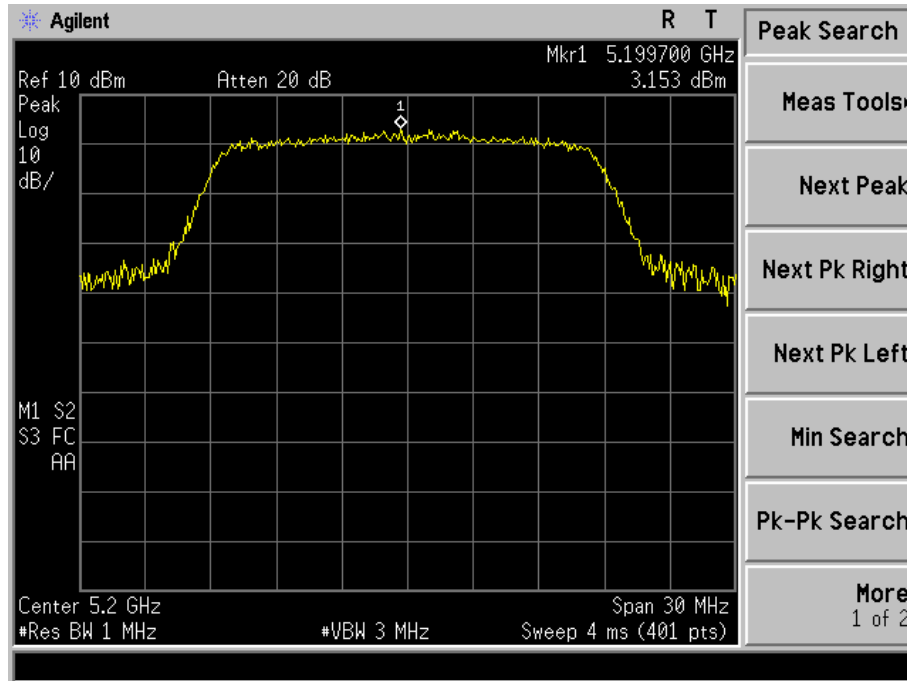

Ant.2 5200MHz

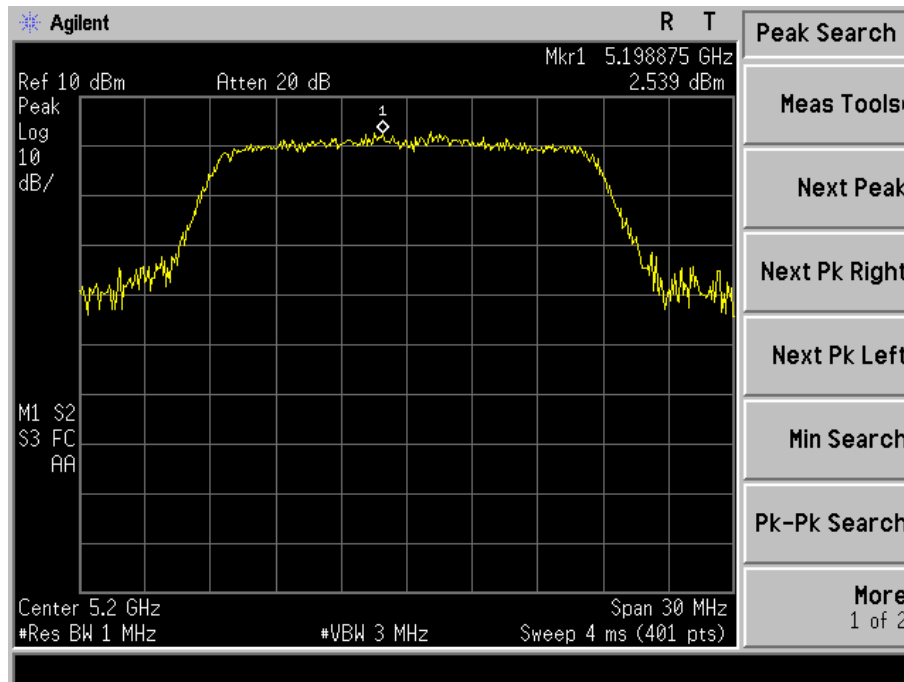



9. DUTY CYCLE TEST SIGNAL

Pre-analysis Check: While conducting average power measurement, duty cycle of each mode shall be checked to ensure its duty cycle in order to compensate for the loss due to insufficient ratio of duty cycle.

All duty cycle is pre-scanned, and result as obtained below shows only the most representative ones where duty cycle is conducted as the given transmission with given virtual operation that expresses the percentage.

Formula:

$$\text{Duty Cycle} = \text{Ton} / (\text{Ton} + \text{Toff})$$

Measurement Procedure:

1. Set span = Zero
2. RBW = 8MHz
3. VBW = 8MHz,
4. Detector = Peak

Duty Cycle:

Operation Mode	Duty Cycle	Duty Fator (dB) $10 * \log (1/ \text{Duty cycle})$
5200MHz	100%	0

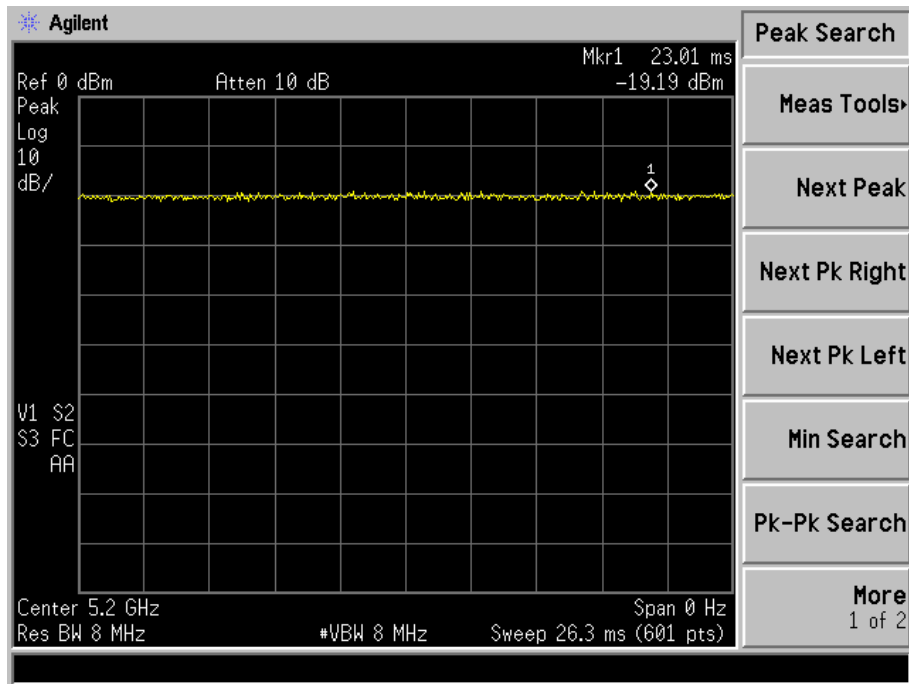

10. FREQUENCY STABILITY

10.1. Limits

Manufacturers of U-NII devices are responsible for ensuring frequency stability such that an emission is maintained within the band of operation under all conditions of normal operation as specified in the user's manual.

The transmitter center frequency tolerance shall be ± 20 ppm maximum for the 5 GHz band (IEEE802.11n specification).

10.2. Test Procedures

1. The transmitter output (antenna port) was connected to the spectrum analyzer.
2. EUT have transmitted absence of modulation signal and fixed channelize.
3. Set the spectrum analyzer span to view the entire absence of modulation emissions bandwidth.
4. Set RBW = 10 kHz, VBW = 10 kHz with peak detector and maxhold settings.
5. f_c is declaring of channel frequency. Then the frequency error formula is $(f_c - f) / f_c \times 10^6$ ppm and the limit is less than ± 20 ppm (IEEE 802.11n specification).
6. The test extreme voltage is to change the primary supply voltage from 85 to 115 percent of the nominal value
7. Extreme temperature is $-20^\circ\text{C} \sim 70^\circ\text{C}$.

10.3. Test Setup Layout

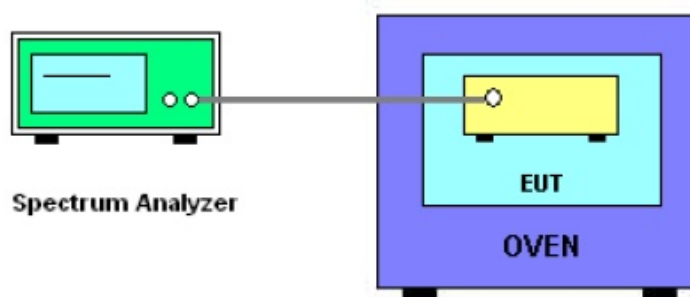

10.4. EUT Operation during Test

The EUT was programmed to be in continuously un-modulation transmitting mode.



10.5. Test Results

Temperature:	25 °C	Relative Humidity:	56%
Pressure:	1015 hPa	Test Voltage :	DC 12V
Test Mode :	Ant.1 TX		

Voltage vs. Frequency Stability

TEST CONDITIONS				Reference Frequency: 5200MHz			
				f	fc	Max. Deviation (MHz)	Max. Deviation (ppm)
T nom (°C)	20	V nom (V)	5.00	5200.02012	5200	0.02012	-3.8692
		V max (V)	5.75	5200.02124	5200	0.02124	-4.0846
		V min (V)	4.25	5200.01946	5200	0.01946	-3.7423
Limits				± 20 ppm			
Result				Complies			

Temperature vs. Frequency Stability

TEST CONDITIONS				Reference Frequency: 5200MHz			
				f	fc	Max. Deviation (MHz)	Max. Deviation (ppm)
V nom (V)	5	T (°C)	-20	5200.00868	5200	0.00868	-1.6692
		T (°C)	-10	5200.00635	5200	0.00635	-1.2212
		T (°C)	0	5200.01651	5200	0.01651	-3.1750
		T (°C)	10	5200.01245	5200	0.01245	-2.3942
		T (°C)	20	5200.02012	5200	0.02012	-3.8692
		T (°C)	30	5200.02037	5200	0.02037	-3.9173
		T (°C)	40	5200.02112	5200	0.02112	-4.0615
		T (°C)	50	5200.02475	5200	0.02475	-4.7596
		T (°C)	60	5200.02189	5200	0.02189	-4.2096
		T (°C)	70	5200.02221	5200	0.02221	-4.2712
Limits				± 20 ppm			
Result				Complies			



Temperature:	25 °C	Relative Humidity:	56%
Pressure:	1015 hPa	Test Voltage :	DC 12V
Test Mode :	Ant.2 TX		

Voltage vs. Frequency Stability

TEST CONDITIONS				Reference Frequency: 5200MHz			
				f	fc	Max. Deviation (MHz)	Max. Deviation (ppm)
T nom (°C)	20	V nom (V)	5.00	5200.01152	5200	0.01152	-2.2154
		V max (V)	5.75	5200.01145	5200	0.01145	-2.2019
		V min (V)	4.25	5200.02051	5200	0.02051	-3.9442
Limits				± 20 ppm			
Result				Complies			

Temperature vs. Frequency Stability

TEST CONDITIONS				Reference Frequency: 5200MHz			
				f	fc	Max. Deviation (MHz)	Max. Deviation (ppm)
V nom (V)	5	T (°C)	-20	5200.01216	5200	0.01216	-2.3385
		T (°C)	-10	5200.01336	5200	0.01336	-2.5692
		T (°C)	0	5200.01647	5200	0.01647	-3.1673
		T (°C)	10	5200.01213	5200	0.01213	-2.3327
		T (°C)	20	5200.01152	5200	0.01152	-2.2154
		T (°C)	30	5200.02347	5200	0.02347	-4.5135
		T (°C)	40	5200.02127	5200	0.02127	-4.0904
		T (°C)	50	5200.02453	5200	0.02453	-4.7173
		T (°C)	60	5200.02124	5200	0.02124	-4.0846
		T (°C)	70	5200.02069	5200	0.02069	-3.9788
Limits				± 20 ppm			
Result				Complies			



11. TRANSMISSION IN THE ABSENCE OF DATA

11.1. Limits

According to §15.407(c)

The device shall automatically discontinue transmission in case of either absence of information to transmit or operational failure. These provisions are not intended to preclude the transmission of control or signaling information or the use of repetitive codes used by certain digital technologies to complete frame or burst intervals. Applicants shall include in their application for equipment authorization a description of how this requirement is met.

11.2. Test result

No non-compliance noted:

Refer to the theory of operation.



12. ANTENNA REQUIREMENT

12.1. STANDARD REQUIREMENT

15.203 requirement: For intentional device, according to 15.203: an intentional radiator shall be designed to ensure that no antenna other than that furnished by the responsible party shall be used with the device.

12.2. EUT ANTENNA

The EUT antenna is Permanent Connection External antenna, It comply with the standard requirement.

13. PHOTOGRAPHS OF TEST SET-UP

Conducted Emission Photos



Radiated Emission Test

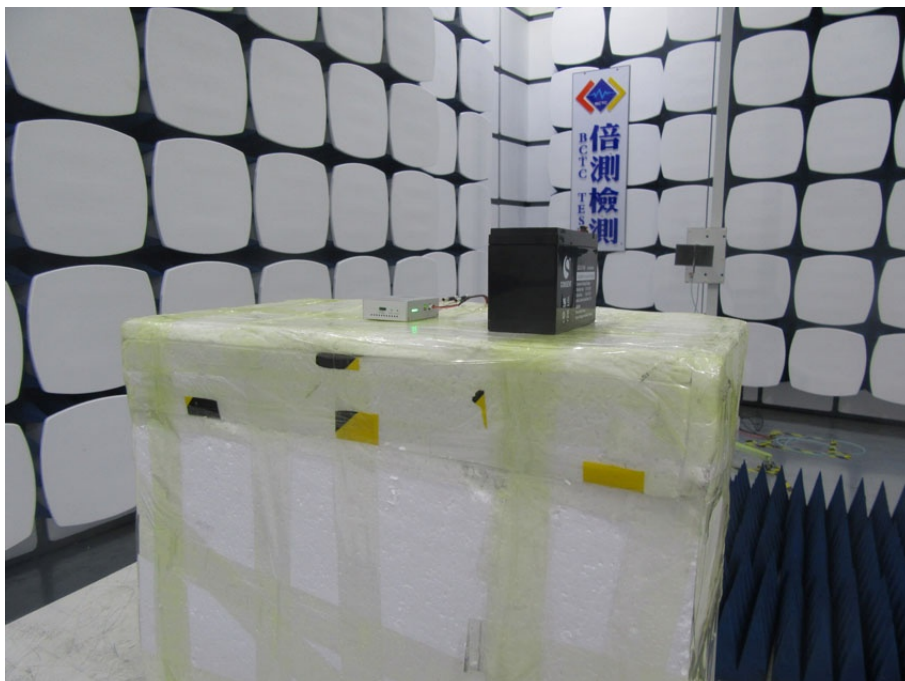
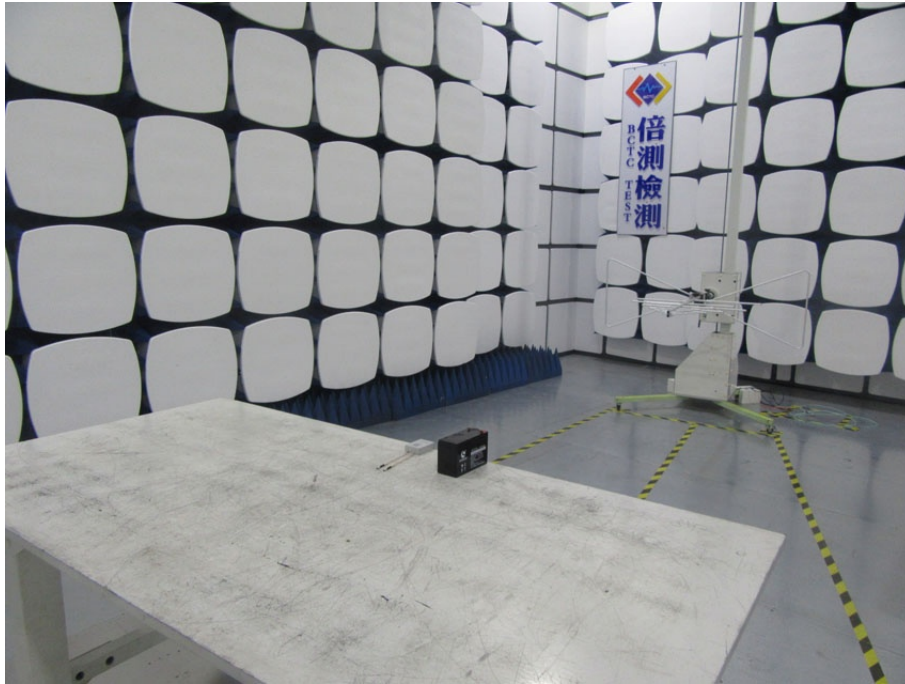

14. PHOTOGRAPHS OF THE EUT

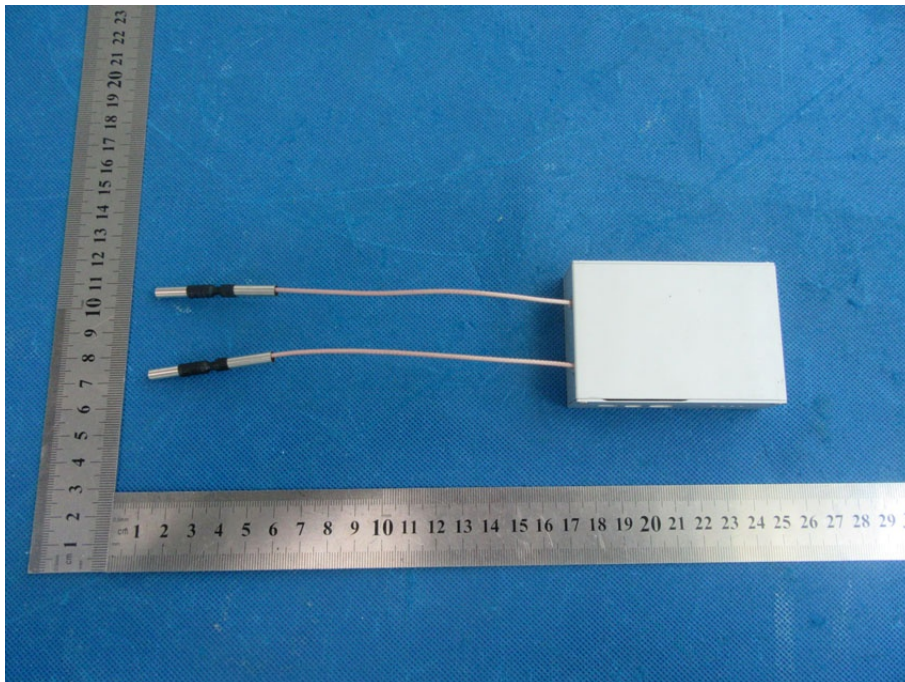
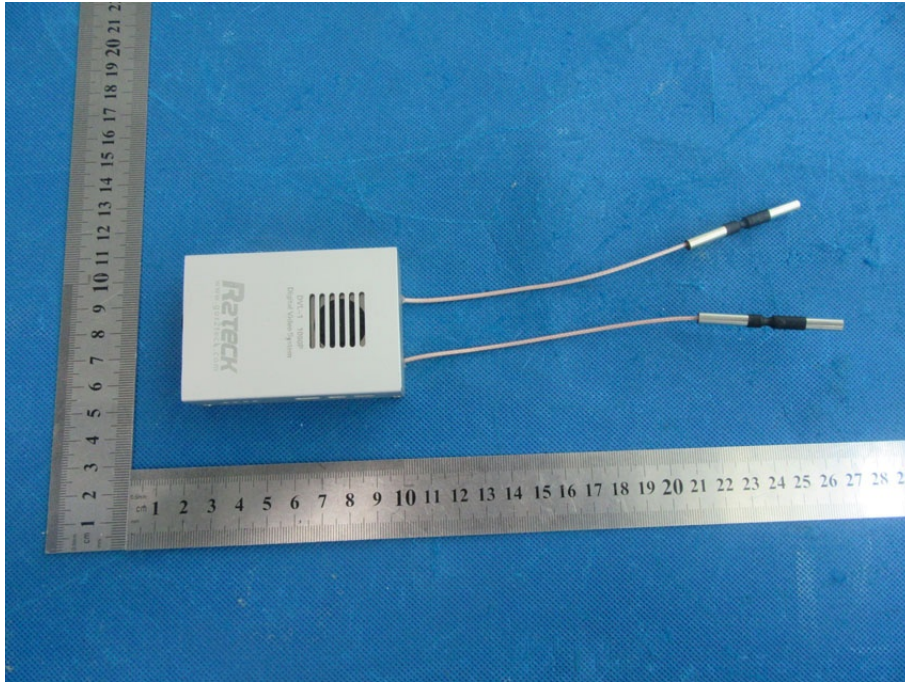

-----END-----