RSP-9003

Installation & User Guide

Revision 0.7



Encinitas Laboratories, Inc. Corporate Headquarters
2386 Faraday Avenue, Suite 140
Carlsbad, CA 92008
U.S.A.
<http://www.encinitaslabs.com>

The information contained herein is proprietary and is provided solely for the purpose of allowing customers to install and configure Encinitas Labs manufactured equipment and is not to be released, reproduced, or used for any other purpose without written permission of Encinitas Laboratories, Inc.

Information and specifications contained in this document are subject to change without prior notice and do not represent a commitment on the part of Encinitas Laboratories, Inc.

© 2014 – 2017 by Encinitas Laboratories, Inc. All rights reserved.

Revision History

Date	Revision	Description
4/20/17	0.5	Initial draft release
7/06/17	0.6	Added maximum power output and RF exposure warning verbiage
8/08/17	0.7	Added French user notices and “contains” ... module verbiage

Table of Contents

1 INTRODUCTION	7
1.1 FEDERAL COMMUNICATIONS COMMISSION (FCC) COMPLIANCE.....	8
1.2 INDUSTRY CANADA (IC) COMPLIANCE.....	9
1.3 EUROPE – EU DECLARATION OF CONFORMITY	10
1.3.1 OTHER REGULATORY REQUIREMENTS	10
2 PRODUCT DESCRIPTION.....	11
2.1 FEATURES.....	11
2.1.1 PASSIVE INFRA-RED DETECTOR	11
2.1.2 INTERNAL RFID ANTENNA.....	11
2.1.3 ACCELEROMETER/MAGNETOMETER	11
2.1.4 TEMPERATURE/HUMIDITY.....	11
2.1.5 UHF RFID READER	11
3 SYSTEM DESCRIPTION	12
4 PRODUCT SPECIFICATION (RSP-9003).....	13
5 HARDWARE DESCRIPTION	14
5.1 MOUNTING HOLES	14
5.2 MOTION SENSOR M1	14
5.3 CONNECTOR J1 (RJ-45).....	14
5.4 VISUAL INDICATOR D1 (TRI-COLOR LED)	15
5.4.1 OFF	15
5.4.2 GREEN (POWER ON).....	15
5.4.3 LIGHT BLUE.....	15
5.4.4 FLASHING WHITE	15
5.4.5 SOLID PURPLE.....	15
5.4.6 FLASHING PURPLE	15
5.4.7 SOLID YELLOW (IDLE).....	15
5.4.8 BLUE.....	15
5.4.9 FLASHING BLUE.....	15
5.4.10 FLASHING RED	15
6 SOFTWARE DESCRIPTION.....	16
6.1 OPERATING SYSTEM	16
6.2 COMMAND LINE INTERFACE.....	16
6.3 RFID GATEWAY COMMAND SET	16
6.4 REMOTE MANAGEMENT	16
7 THEORY OF OPERATION.....	16
7.1.1 RFID GATEWAY DISCOVERY	17
7.1.2 RFID BEHAVIOR CONTROL.....	18
7.1.3 MANAGING LARGE TAG POPULATIONS.....	21
7.1.3.1 Normal Scan (Dual Target).....	22



7.1.3.2 High Mobility (Dual Target)..... 23
7.1.3.3 Deep Scan (Single Target)..... 24
7.1.4 SEARCHING FOR A SINGLE TAG OR GROUP OF TAGS..... 25
7.1.4.1 Tag "Select" 26
7.1.4.2 "Post Match" Filtered Inventory..... 27

8 SYSTEM INSTALLATION..... 28

8.1 RF EXPOSURE STATEMENT..... 28
8.2 INFORMATION TO THE USER..... 28
8.3 CABLING INFRASTRUCTURE..... 29
8.3.1 CORRECT WIRING STANDARDS 29
8.3.2 PROPER CABLE TYPE 30
8.3.3 PROPER CABLE LENGTH..... 30
8.3.4 ENVIRONMENTAL CONDITIONS..... 30
8.3.5 POWER OVER ETHERNET 31
8.4 CONNECTIVITY..... 31
8.4.1 PHYSICAL..... 31
8.4.2 NETWORK DIAGRAM..... 32
8.5 MOUNTING..... 33
8.5.1 TRACK LIGHT MOUNTING BRACKET 34
8.5.2 WALL MOUNTING BRACKET..... 35

9 COMMAND LINE INTERFACE (CLI) SUPPORT..... 36

9.1 TOP LEVEL..... 37
9.2 RFID PROTOCOL COMMANDS..... 37
9.3 RFID SELECT COMMANDS..... 38
9.4 LOG COMMANDS..... 38
9.5 RFID RADIO COMMANDS..... 38
9.6 LED COMMANDS..... 39
9.7 VERSION COMMANDS..... 39
9.8 SSL COMMANDS..... 39
9.9 RSP COMMANDS..... 40
9.10 TAG COMMANDS..... 40
9.11 SYSTEM COMMANDS..... 40
9.12 RFID TEST COMMANDS..... 41
9.13 RFID PLATFORM COMMANDS..... 42
9.14 RFID QUERY COMMANDS..... 42

Table of Figures

Figure 1 Example RFID Deployment using Retail Sensor Platforms	12
Figure 2 RSP-9003.....	14
Figure 3 Gateway Discoveries.....	17
Figure 4 Normal Scan (Dual Target).....	22
Figure 5 High Mobility (Dual Target).....	23
Figure 6 Deep Scan using Filtered Inventory.....	24
Figure 7 Tag "Select".....	26
Figure 8 Configuring a Post Match Inventory.....	27
Figure 9 T-568A vs. T-568B.....	29
Figure 10 Physical In-Store Connectivity	31
Figure 11 Network Diagram and Firewall Rules	32
Figure 12 Black Track Light Mounted RSP	33
Figure 13 White Track Light Mounted RSP	33
Figure 14 Track Light Assembly	34
Figure 15 RSP Wall Mount Assembly.....	35



1 Introduction

This document is a guide for the installation, setup and use of the RSP-9003 Retail Sensor Platform (Revision 1B).

THE REMAINDER OF THIS PAGE IS INTENTIONALLY LEFT BLANK.

1.1 Federal Communications Commission (FCC) Compliance

This device, which contains FCC ID: 2ALVR-9271 and IC: 22664-9271, complies with FCC Part 15 and ISED license-exempt RSS standards. Operation is subject to the following two conditions: (1) this device may not cause interference, and (2) this device must accept any interference, including interference that may cause undesired operation of the device.

Cet appareil, qui contient ID FCC: 2ALVR-9271 et IC: 22664-9271, est conforme aux exigences FCC et ISED pour les appareils radio autorisés. L'opération est soumise aux deux conditions suivantes: (1) cet appareil ne doit pas provoquer d'interférence, et (2) cet appareil peut provoquer des interférences, y compris des interférences pouvant entraîner un fonctionnement indésirable.



Caution: Changes to this product or modifications not expressly approved by the party responsible for compliance could void your authority to operate the equipment.

Antennas used for this device must be installed to provide a separation distance of at least 30 cm from all persons, and must not be co-located or operating in conjunction with any other antenna or transmitter. Users and installers must be provided installation instructions and transmitter operating conditions for satisfying RF exposure compliance.

L'antenne (s) utilisée (s) pour cet émetteur doit être installée pour assurer une distance de séparation d'au moins 30 cm de Personnes et ne doivent pas être co-situés ou fonctionner conjointement avec une autre antenne ou émetteur. Utilisateurs et Les installateurs doivent être munis d'instructions d'installation d'antenne et de conditions d'exploitation de l'émetteur pour conformité à l'exposition RF.

1.2 Industry Canada (IC) Compliance

This device, which contains FCC ID: 2ALVR-9271 and IC: 22664-9271, complies with FCC Part 15 and ISED license-exempt RSS standards. Operation is subject to the following two conditions: (1) this device may not cause interference, and (2) this device must accept any interference, including interference that may cause undesired operation of the device.

Cet appareil, qui contient ID FCC: 2ALVR-9271 et IC: 22664-9271, est conforme aux exigences FCC et ISED pour les appareils radio autorisés. L'opération est soumise aux deux conditions suivantes: (1) cet appareil ne doit pas provoquer d'interférence, et (2) cet appareil peut provoquer des interférences, y compris des interférences pouvant entraîner un fonctionnement indésirable.



Caution: Changes to this product or modifications not expressly approved by the party responsible for compliance could void your authority to operate the equipment.

1.3 Europe – EU Declaration of Conformity

Hereby, Encinitas Laboratories, Inc. declares that the radio equipment type RSP-9003 is in compliance with...

- Radio Equipment Directive (RED) 2014/53/EU
- EU directive 2011/65/EU (RoHS II)

The full text of the EU declaration of conformity is available at the following internet address:

1.3.1 Other Regulatory Requirements

Hereby, Encinitas Laboratories, Inc. declares that the radio equipment type RSP-9003 is in compliance with...

- REACH Regulation (EC) 1907/2006
- WEEE Directive 2012/19/EU

2 Product Description

The RSP-9003 and RSP-9800 are members of the “Smart Sensor” family that is part of the Intel© Responsive Retail System (RRS). These devices have capabilities for several on-board sensors including an EPC Gen 2 UHF RFID Interrogator (reader). These sensors are designed to work stand-alone, or in a network of other “Smart Sensors” as part of an Internet-of-Things (IoT) system where computing power is pushed out to the edge devices.

2.1 Features

The RSP-9003 is designed to be ceiling or wall mounted facing into the retail space and hidden from view. The following features are unique to the RSP-9003.

2.1.1 Passive Infra-Red Detector

A passive infra-red detector is used to detect human motion.

2.1.2 Internal RFID Antenna

The RSP-9003 uses an internal 5.5 dBi Dual Linear antenna.

2.1.3 Accelerometer/Magnetometer

The common PCBA includes a 3D accelerometer/magnetometer device suitable for reading the orientation of the device as it is mounted.

2.1.4 Temperature/Humidity

The common PCBA includes a temperature and humidity device suitable for reading the environment that the PCB is exposed to.

2.1.5 UHF RFID Reader

The common PCBA includes a UHF EPC Gen 2 RFID Reader module. This module supports the core functionality of RRS (i.e. inventory management).

3 System Description

The RSP-9003 is just one component of the larger Intel® Responsive Retail Platform (RRP) shown in Figure 1 below. The system is comprised of one or more Retail Sensor Platforms, an RFID Gateway for control and orchestration and a Cloud Application Server for data storage, analytics and remote management of the entire System.

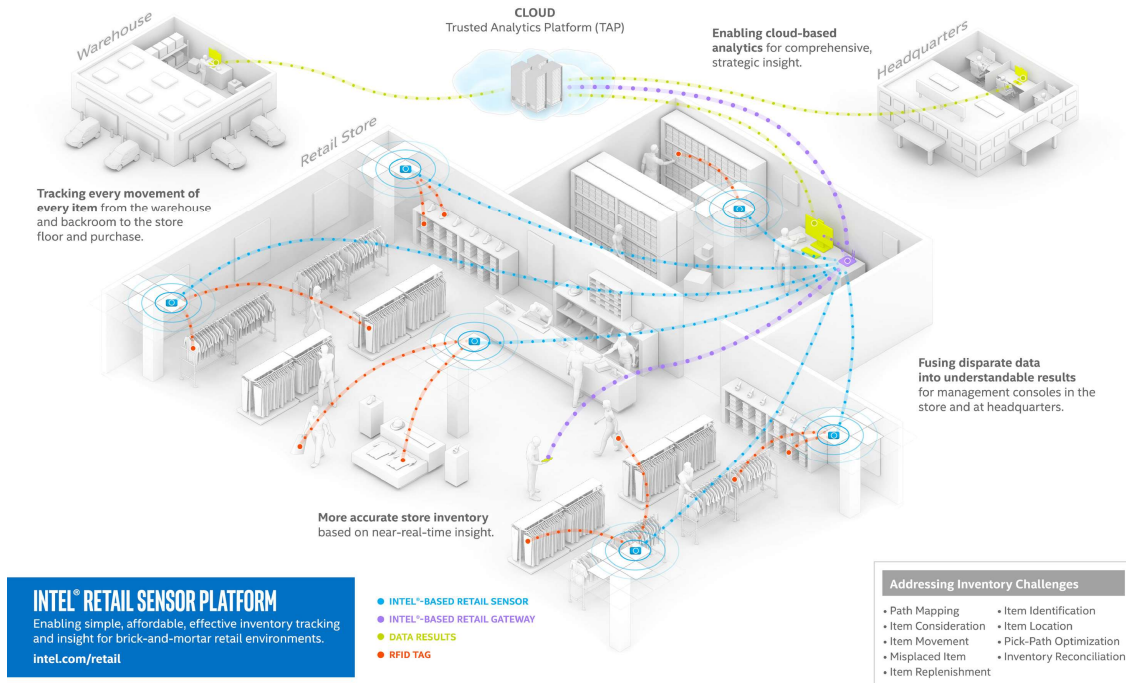

Figure 1 Example RFID Deployment using Retail Sensor Platforms

The power of the RRP is in the networked communication and coordination that exists between the RSP's themselves and between the RSP and the RFID Retail Gateway. Whether a system deployment has 5 or 500 Retail Sensor Platforms, this communication and coordination greatly simplifies initial configuration as well as the operational management.

4 Product Specification (RSP-9003)

Electrical:	
Air Interface Protocol	EPC UHF RFID Class 1 Gen 2 (ISO 18000-6C)
Operating Frequency	902-928 MHz (FCC), 865-868 MHz (ETSI)
Radiated Power	Up to 4W EIRP (2W ERP)
Antenna	Integrated Dual-Linear Polarity
Power Source	POE (802.3af, 802.3at, Cisco UPOE)
Power Consumption	13W max, 5W idle
Tag Read Range	> 15m
Tag Read Rate	> 600 tag reads / sec.
Visual Indicators	Single tri-color LED
Mechanical:	
Dimensions	9" x 9" x 2" (23 cm x 23 cm x 5 cm)
Weight	2.3 lbs. (1.0 kg)
Mounting	Vesa 75 mm pattern, M4 threads
Color	Black and White available
Environmental:	
Operating Temperature	0 to +50 degrees C
Rating	IP-50
Application Interface:	
Network Connectivity	Ethernet 10/100
IP Address Configuration	DHCP or Static
Data Protocols	JSON-RPC 2.0 over MQTT
Configuration / Management	mDNS/DNS-SD, MeshCentral
Time Synchronization	NTP
Software / Firmware Updates	Remote Push
Regulatory:	
Safety Compliance	IEC 60950-1
RF Certifications	FCC Part 15.247 C, ETSI EN 302208-1

5 Hardware Description

Figure 2 highlights the external interfaces of the RSP-9003 from Encinitas Labs.

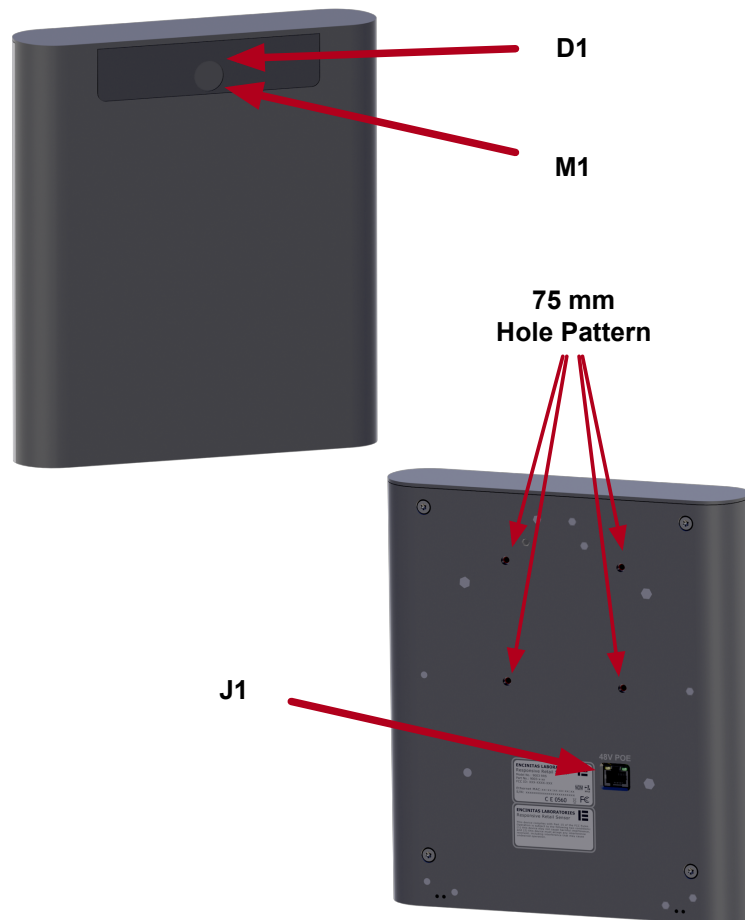

Figure 2 RSP-9003

5.1 Mounting Holes

The RSP-9003 provides a 75-mm hole pattern compatible with several types of mounting brackets. The holes are threaded to accept up to a 1 cm M4 stud.

5.2 Motion Sensor M1

The RSP-9003 uses a passive infrared sensor to detect human motion in the field of the RFID antenna.

5.3 Connector J1 (RJ-45)

The RSP-9003 is a 48V Power Over Ethernet (POE) Class 3 device as defined in IEEE 802.3af. The RSP-9003 supports 10/100 Ethernet on this same connector.

5.4 Visual Indicator D1 (Tri-Color LED)

The RSP-9003 provides a multicolored visual indicator to notify the user of the following operational states.

5.4.1 OFF

An LED state of "off" indicates the RSP-9003 has either been commanded to disable its visual indicator or is otherwise non-operational.

5.4.2 GREEN (Power On)

An LED state of "solid green" is the default to indicate power has been successfully applied to the RSP. This initial LED state should not last longer than 2 – 3 minutes. After 2 – 3 minutes, the LED color should transition to indicate successful OS boot.

5.4.3 Light BLUE

An LED state of "solid light blue" indicates the RSP-9003 has successfully booted to the Linux OS, but the RFID Applications are not yet running.

5.4.4 Flashing WHITE

An LED state of "flashing white" after boot up indicates the RSP-9003 is in the process of discovering the RFID Gateway. The state of "flashing white" can also be commanded (i.e. Beacon Mode) by the Gateway via JavaScript Object Notation (JSON) Remote Procedure Call (RPC) for visually identifying the RSP.

5.4.5 Solid PURPLE

An LED state of "solid purple" indicates the RSP-9003 is waiting to read a security provisioning tag.

5.4.6 Flashing PURPLE

After a security provisioning tag has been successfully read, the RSP-9003 LED state will be "flashing purple" for a period of 5 seconds.

5.4.7 Solid Yellow (Idle)

Following Gateway Discovery, an LED state of "solid yellow" indicates that The RSP-9003 is in the idle state and ready to accept commands.

5.4.8 BLUE

An LED state of "solid blue" indicates the RSP-9003 is currently in an Inventory Cycle (i.e. transmitting) but not receiving any tag data.

5.4.9 Flashing BLUE

An LED state of "flashing blue" indicates the RSP-9003 is currently in an Inventory Cycle (i.e. transmitting) and successfully communicating with RFID tags.

5.4.10 Flashing RED

An LED state of "flashing red" indicates the RSP-9003 has detected a failure. This will continue until the alert is acknowledged by the RFID Gateway or the CLI.

6 Software Description

6.1 Operating System

The RSP-9003 from Encinitas Labs uses the Intel® Quark™ processor running a Yocto Project Linux kernel and a Debian Linux file system.

6.2 Command Line Interface

The RSP-9003 supports a comprehensive set of command line functions that provide the user with a useful tool for testing tags and developing macro level RFID applications.

6.3 RFID Gateway Command Set

The RSP-9003 supports a JSON RPC 2.0 command set over MQTT© that allows it to be a smart slave device controlled by the RFID Gateway.

6.4 Remote Management

The RSP-9003 supports web based remote monitoring and management services via MeshCentral technology.

7 Theory of Operation

The power of RRP is in the networked communication and coordination that exists between the Sensor Platforms themselves and between the RFID Gateway. Whether a particular RFID system deployment has 5 or 500 RSP devices, this communication and coordination greatly simplifies initial configuration as well as the operational management. This section defines the set of messages used between the RFID Retail Sensor Platform and the RFID Gateway that facilitates this orchestration.

Some of these messages affect the RF power output and modulation scheme being transmitted. The Impinj R2000 RF subsystem buffers all commands received from the RFID Gateway via the Host Processor. **NOTE: Any command that attempts to set a parameter to a value that is outside its valid range or would otherwise cause the RSP-9003 to no longer be compliant with its certification will return an error code and the previous command settings will persist.**

Several Use Cases have been defined that illustrate initial discovery, configuration and tag population management. Detailed message definitions can be found in the Retail Sensor Platform API.

7.1.1 RFID Gateway Discovery

A goal of the RFID Sensor Platform is to be as much of a “zero-conf” installation as possible. Once power is applied, the RSP Sensor autonomously acquires a network address via DHCP and discover the RSP Gateway. It then synchronizes its system clock and registers with the MeshCentral Server. The RSP Sensor also supports encryption via a TLS connection to the MQTT broker. An optional “provisioning tag” containing a hash and token can be used for the RSP Sensor to authenticate the Cloud and the RSP Gateway to authenticate the sensor as it connects. **Error! Reference source not found.** illustrates the message exchange involved in this use case.

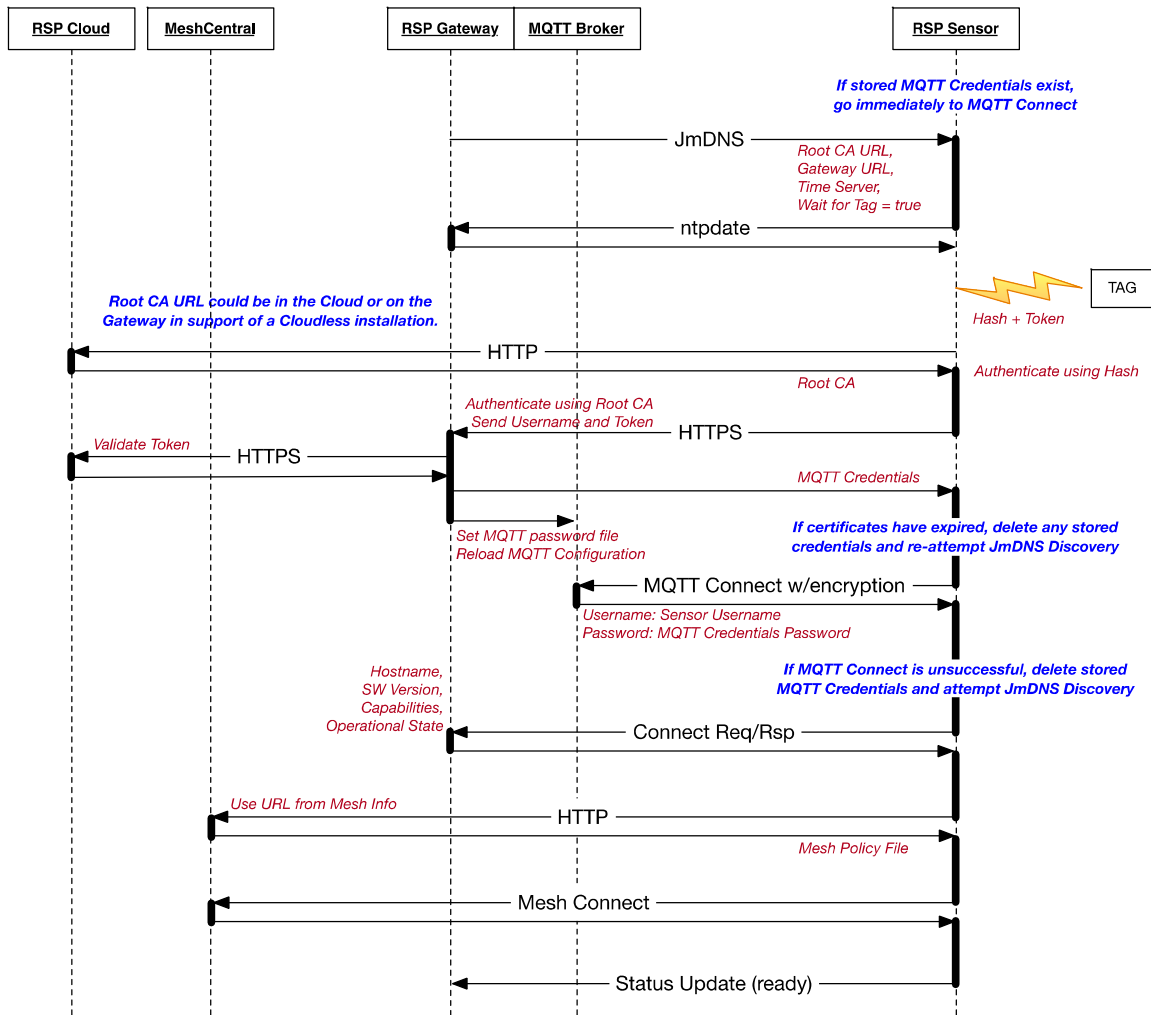

Figure 3 Gateway Discoveries

7.1.2 RFID Behavior Control

In addition to using default values, the RFID Sensor Platform supports the detailed RFID configuration via the “apply_behavior” API command. This command is shown below (see the RFID API Command Set document for a complete set of command definitions).

Table 1 Apply Behavior Parameters

Parameter	Definition
action	Specifies the action to be taken. The valid values are “START” and “STOP”.
action_time	Specifies the millisecond epoch time to apply the behavior. If zero or not included, the behavior is applied immediately.
behavior	Optional set of behavior parameters (see below).
id	The ID string assigned to this behavior
operation_mode	The embedded RFID module transmit operation mode. The valid values are "Continuous" and "NonContinuous". The default value is "NonContinuous".
link_profile	The RF Link Profile to be used for this behavior. (see Table 2 Link Profile Parameters) The valid range is 0 – 4.
power_level	The power output level in dBm to be used for this behavior. The valid range is 0 – 31.5.
dwel_time	The maximum amount of time (ms) spent on a particular virtual port before switching to the next virtual port during an inventory cycle. If this parameter is zero, the “inv_cycles” parameter may not be zero. The valid range is 0 – 65535.
inv_cycles	The maximum amount of inventory cycles to attempt on a particular virtual port before switching to the next virtual port during an inventory cycle. If this parameter is zero, the “dwel_time” parameter may not be zero. The valid range is 0 – 65535.
selected_state	Specifies the state of the “SL” flag to be used for this behavior when specifying a select protocol operation. The valid values are: “Any”, “Deasserted” and “Asserted”.
session_flag	Specifies which inventory session flag is matched against the state specified by “target_state”. (see Table 3 Session Flag Persistence Values) The valid values are “S0”, “S1”, “S2” and “S3”.
target_state	Specifies the state of the inventory session flag specified by “session_flag” that are to apply the subsequent tag protocol operation. (see Table 3 Session Flag Persistence Values) The valid values are “A” and “B”.
q_algorithm	The specific Q algorithm being configured. The valid values are “Fixed” and “Dynamic”. When using a “Fixed” algorithm, the number of time slots is 2^Q . When using a “Dynamic” algorithm, the Smart Sensor Platform’s embedded module will vary the number of slots

	dynamically based on the number of tags responding.
fixed_q_value	The fixed Q value to use (valid when q_algorithm = Fixed). The valid range of this parameter is 0 – 15.
repeat_until_no_tags	Specifies whether or not the singulation algorithm should continue until no more tags are singulated. The valid values are “true” or “false”.
start_q_value	The initial Q value to use at the beginning of an inventory round (valid when q_algorithm = Dynamic). The valid range of this parameter is 0 – 15.
min_q_value	The minimum Q value that would ever be used during an inventory round (valid when q_algorithm = Dynamic). The valid range of this parameter is 0 – 15.
max_q_value	The maximum Q value that would ever be used during an inventory round (valid when q_algorithm = Dynamic). The valid range of this parameter is 0 – 15.
threshold_multiplier	A 4X multiplier applied to the Q-adjustment threshold as part of the dynamic-Q algorithm. The valid range of this parameter is 0 – 255.
retry_count	The number of times to try another execution of the singulation algorithm before either toggling the target flag or terminating the operation. The valid range of this parameter is 0 – 255.
toggle_target_flag	Specifies whether or not to toggle the targeted flag. The valid values are “true” or “false”.
toggle_mode	When toggle_target_flag is true, this value specifies when to toggle the targeted flag. The valid values are “None”, “OnInvCycle”, “OnInvRound”, or “OnReadRate”.
perform_select	Specifies whether or not to perform a select command based on the previously configured criteria The valid values are “true” and “false”.
perform_post_match	Specifies whether or not to perform a post singulation match based on the previously configured criteria. The valid values are “true” and “false”.
filter_duplicates	Specifies whether or not the RFID Sensor Platform should filter out duplicate tag information before sending to the Gateway. The valid values are “true” or “false”.
auto_repeat	Specifies whether or not to continue performing inventory rounds until the “stop_inventory” command is received. When this value is “No”, an “inventory_complete” indication will be sent from the RFID Sensor Platform to the RSP Gateway at the end of the inventory round. The valid values are “true” and “false”.
delay_time	The amount of time (ms) that the transmitter is turned off between subsequent inventory rounds. Used when “auto_repeat” is true to control the transmit duty cycle. The valid range is 0 – 65535.

Table 2 Link Profile Parameters

Parameter / Profile Index	0	1	2	3	4
Modulation Type	DSB-ASK	PR-ASK	PR-ASK	DSB-ASK	DSB-ASK
Tari Duration (us)	25	25	25	6.25	6.25
Data 0/1 Difference	1	0.5	0.5	0.5	0.5
Pulse Width (us)	12.5	12.5	12.5	3.13	3.13
R-T Calculation (us)	75	62.5	62.5	15.63	15.63
T-R Calculation (us)	200	85.33	71.11	20	33.33
Divide Ratio	8	21.33	21.33	8	21.33
Data Encoding	FM0	Miller-4	Miller-4	FM0	FM0
Pilot Tone	1	1	1	1	1
Link Frequency (kHz)	40	250	300	400	640
Data Rate (kbps)	40	62.5	75	400	640

Table 3 Session Flag Persistence Values

Session	Tag Energized	Tag Not Energized
S0	Indefinite	None
S1	500 ms < persistence < 5 s	2 s < persistence
S2	Indefinite	2 s < persistence
S3	Indefinite	2 s < persistence

7.1.3 Managing Large Tag Populations

The RFID Gateway can segregate a large tag population into several smaller ones using the Retail Sensor Platform's "select" and "post-match" functions. Segregation allows the RSP-9003 to more accurately inventory a tag population by avoiding collisions. This same functionality can also be used to isolate a single tag that might be located in a challenging RF environment or perhaps physically oriented in a less than optimal fashion.

A challenge in managing larger tag populations is dealing with "tag collisions" during the query-response (more than one tag responding at exactly the same time). The RSP-9003 offers an adaptive algorithm (Dynamic-Q) function to mitigate tag collisions. An adaptive Q algorithm increases the reading efficiency significantly thereby reducing the time it takes to completely inventory a large tag population. The RSP-9003 allows the RFID Gateway to optimally configure the Q Algorithm based on a known tag population. Dynamic-Q is used by default, which relieves the Gateway from having to explicitly set the Q-value.

7.1.3.1 Normal Scan (Dual Target)

This Use-Case illustrates the most common situation where a number of tagged items are being continuously inventoried on an RFID-enabled “smart shelf” or perhaps an overhead Retail Sensor Platform in an RFID-enabled “smart store”. This mode will allow multiple reads per tag for a moderate update of tag status to alert the RFID system should a tagged item be moved. No tag filtering is specified. Figure 4 illustrates the message exchange involved in this use case.

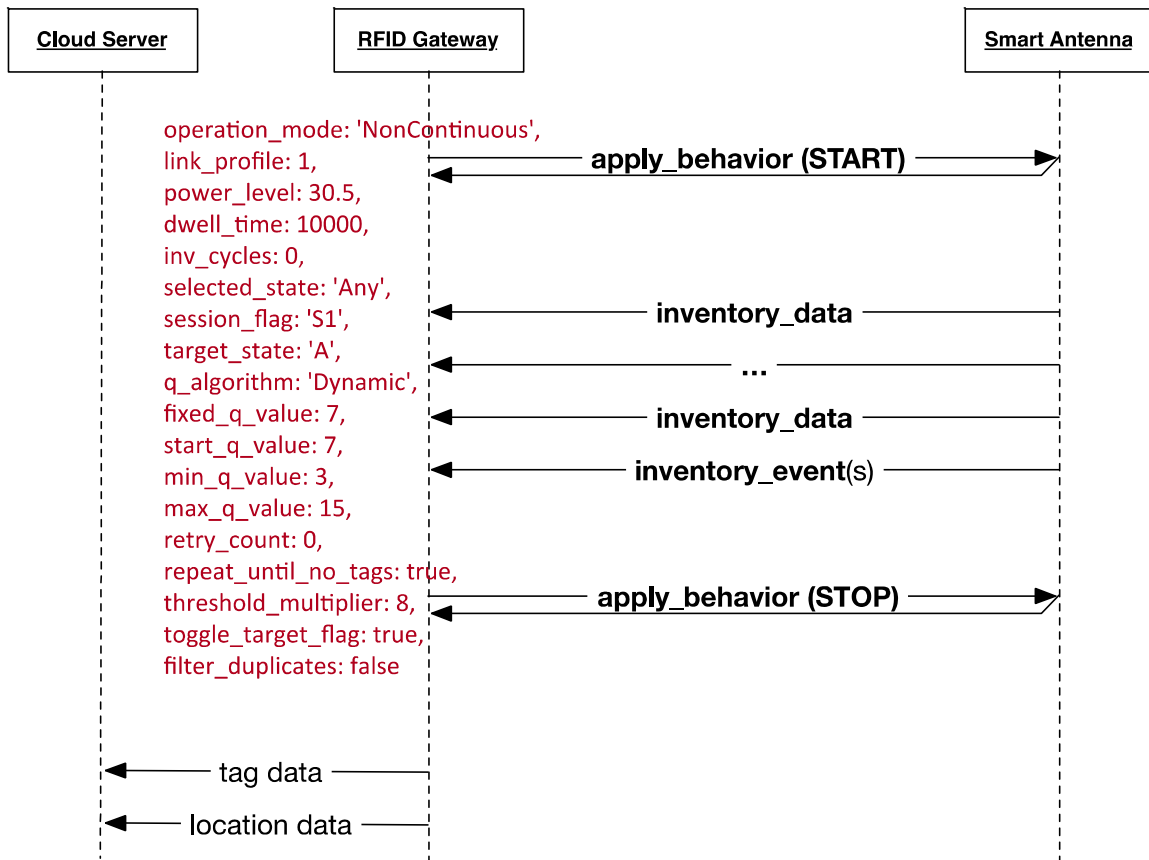

Figure 4 Normal Scan (Dual Target)

7.1.3.2 High Mobility (Dual Target)

This Use-Case addresses the situation where a number of tagged items are being continuously inventoried, and higher numbers of reads per tag are required to detect tag mobility. Figure 4 illustrates the message exchange involved in this use case.

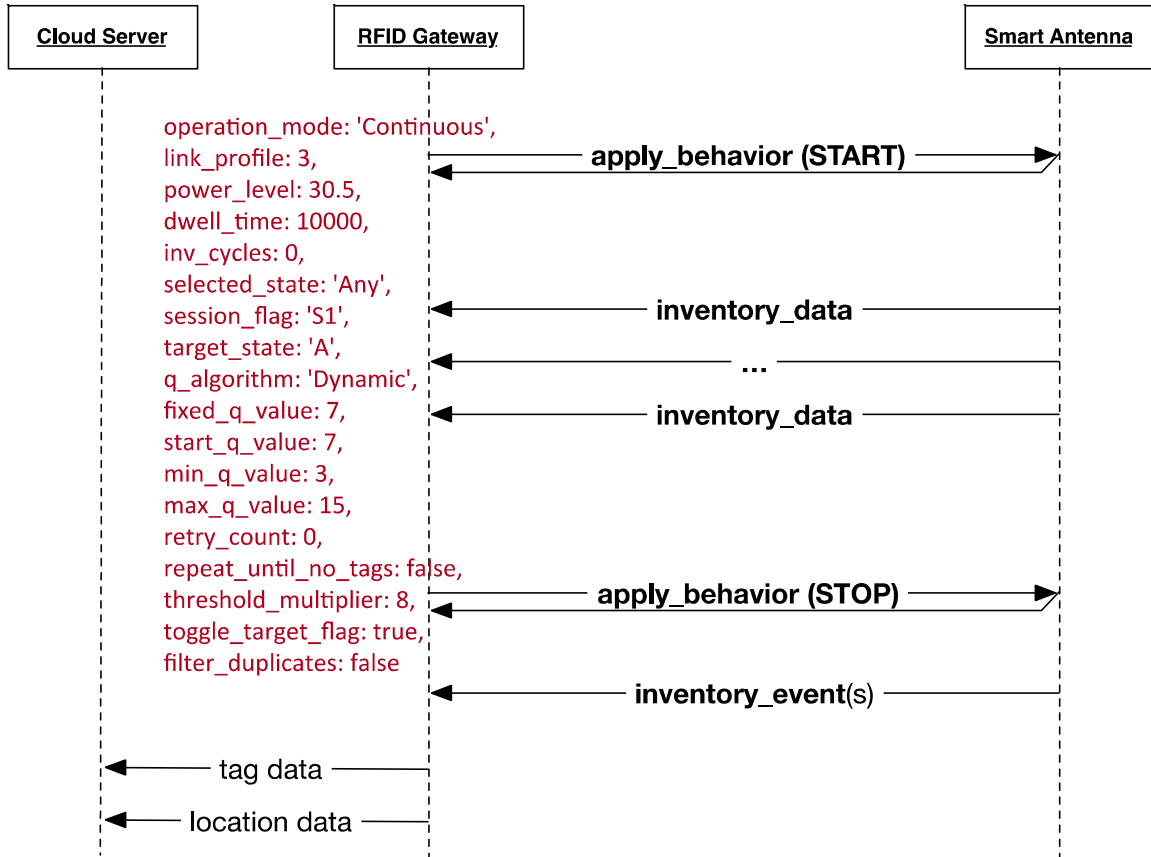

Figure 5 High Mobility (Dual Target)

7.1.3.3 Deep Scan (Single Target)

This Use-Case illustrates a thorough “Deep Scan” using the most robust RF link to insure that all tags within the coverage area are successfully read at least once. This mode also uses suppression to allow weaker tags to respond without competing with the multiple responses of other tags and is recommended only in situations where multiple reads per tag is not required. Sessions 2 and 3 are used to provide longer suppression times while scanning. Alternating between sessions 2 and 3 (and between A and B) allows for a rapid recovery when rescanning the tag population. This use-case insures that even the most distant tags with the weakest backscatter signal can be eventually read. Figure 6 illustrates the message exchange involved in this use case.

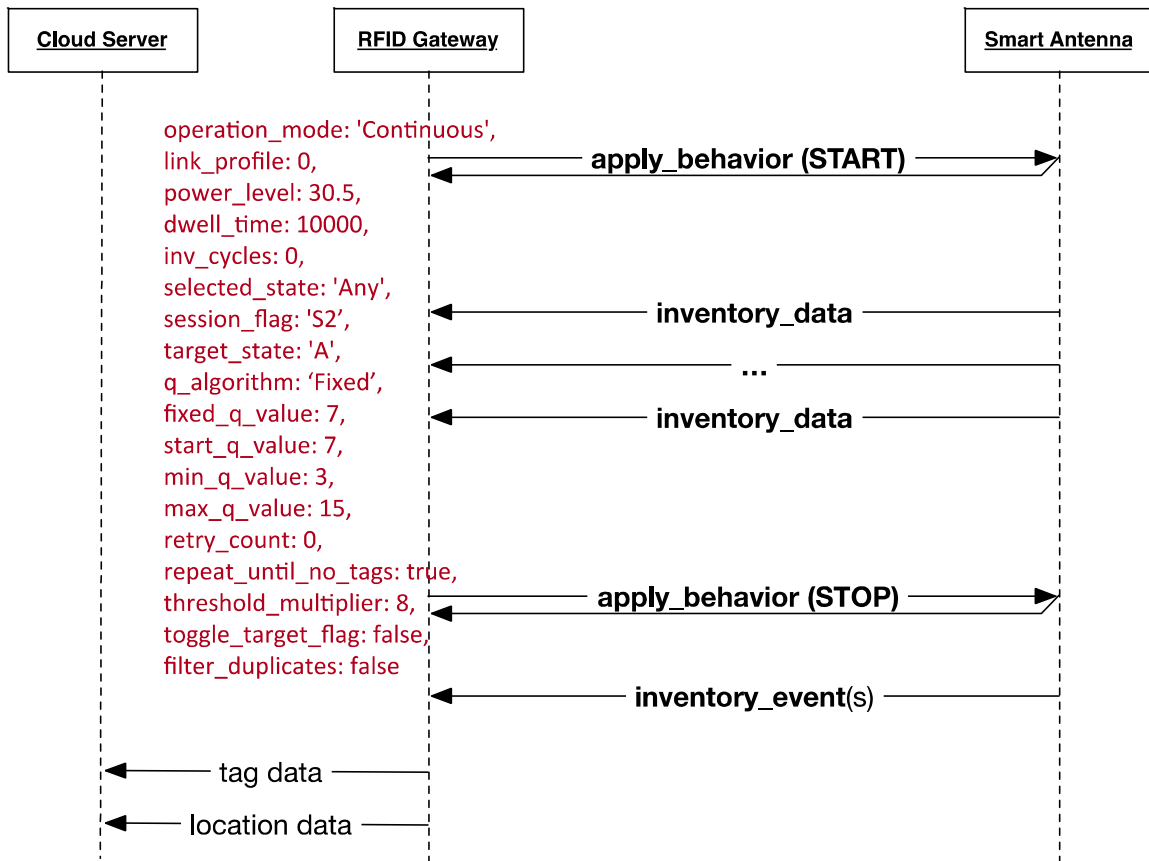

Figure 6 Deep Scan using Filtered Inventory

7.1.4 Searching for a Single Tag or Group of Tags

There are two ways to search for an individual tag or group of tags using The RSP-9003 (RSP).

The "select" function configures the RSP-9003 with set of tag filter criteria and instructs those tags that match that filter criteria to modify a certain register flag, forcing it to a known value prior to singulation. The tag protocol operation (i.e. read, write, kill) is applied only to those tags that meet the filter criteria. When tag populations are relatively large (> 1000) or when it is critical to apply a tag protocol operation to only a single tag, this method of filtering is preferred. A good example of an applied use of the "select" function would be at the point-of-sale (POS) where tags could be deactivated (killed) prior to exiting a controlled area.

The "post-match" function configures The RSP-9003 with set of tag filter criteria that is applied "post" singulation or after a particular tag protocol operation is performed. Even though the tag still has to compete in the RF environment of the singulation process, the only data sent to the RFID Gateway is from those tags that match the filter criteria defined in the "post match" function. "Post Match" filtering is a single step process, tag memory is not modified and all tags respond to the inventory request. When tag populations are relatively small (< 1000), this method of filtering on certain tags is more efficient. A good example of an applied use of the "post match" function would be when searching a larger tag population with a hand scanner for a particular tag or group of tags.

7.1.4.1 Tag "Select"

This Use-Case shows an example of the tag "select" function to search for a single tag or group of tags. Figure 7 below illustrates the message exchange involved in this use case.

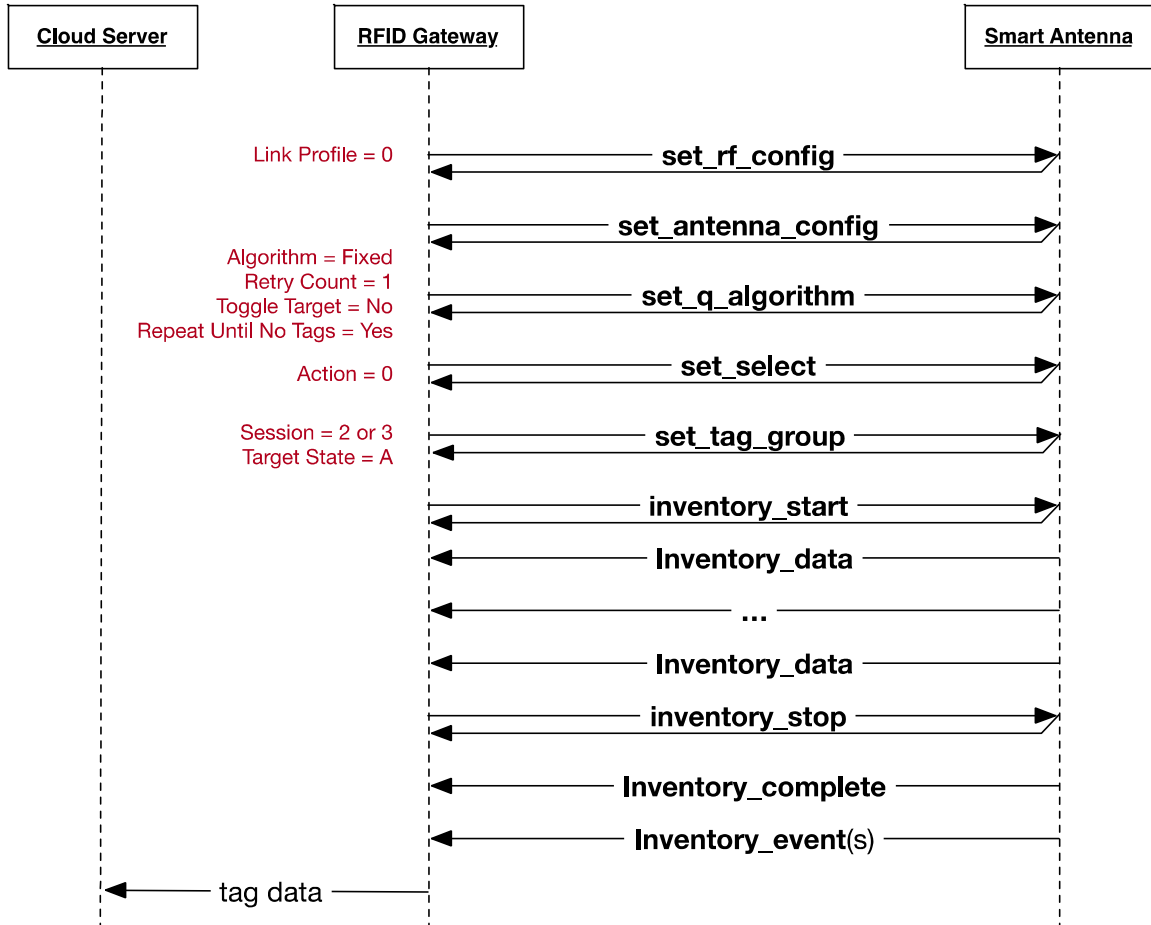

Figure 7 Tag "Select"

7.1.4.2 "Post Match" Filtered Inventory

This Use-Case shows an example of the tag "post match" function to search for a single tag or group of tags. Figure 8 illustrates the message exchange involved in this use case.

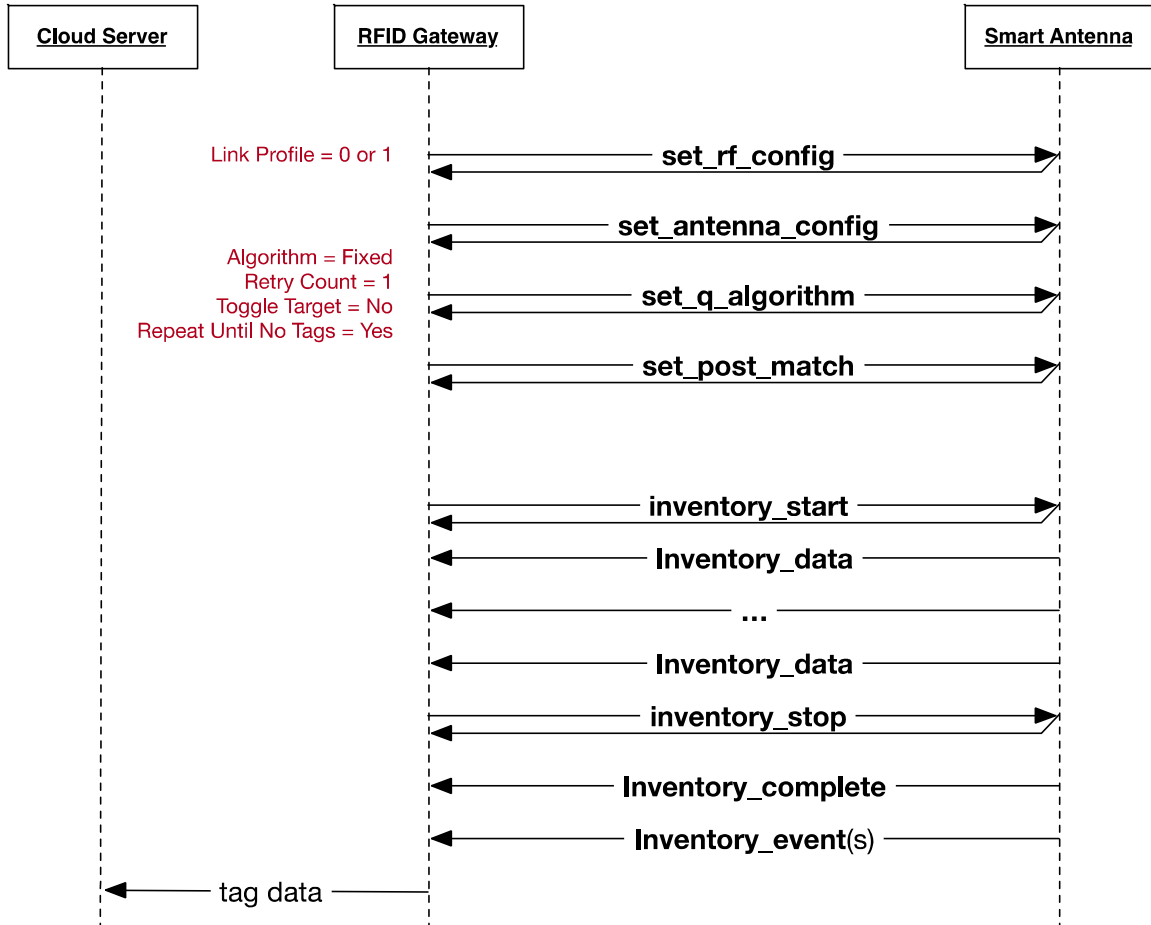

Figure 8 Configuring a Post Match Inventory

8 System Installation

8.1 RF Exposure Statement



Caution: The radiated output power of this device is below the FCC and International radio frequency exposure limits. To avoid the possibility of exceeding these exposure limits, always maintain a minimum distance of 20 cm between the antenna and the human body. Details regarding the authorized configurations can be found at <http://www.fcc.gov/oet/ea/> by entering the FCC ID from the device.



Caution: L'antenne (s) utilisée (s) pour cet émetteur doit être installée pour assurer une distance de séparation d'au moins 20 cm de Personnes et ne doivent pas être co-situés ou fonctionner conjointement avec une autre antenne ou émetteur. Utilisateurs et Les installateurs doivent être munis d'instructions d'installation d'antenne et de conditions d'exploitation de l'émetteur pour Conformité à l'exposition RF.

8.2 Information to the User



§15.105 Information to the user

Note: This equipment has been tested and found to comply with the limits for a Class B digital device, pursuant to part 15 of the FCC Rules. These limits are designed to provide reasonable protection against harmful interference in a residential installation. This equipment generates, uses and can radiate radio frequency energy and, if not installed and used in accordance with the instructions, may cause harmful interference to radio communications. However, there is no guarantee that interference will not occur in a particular installation. If this equipment does cause harmful interference to radio or television reception, which can be determined by turning the equipment off and on, the user is encouraged to try to correct the interference by one or more of the following measures:

- Reorient or relocate the receiving antenna.
- Increase the separation between the equipment and receiver.
- Connect the equipment to another POE source.
- Consult the system integrator or authorized technician for help.

This Class B digital apparatus complies with Canadian ICES-003.

Cet appareil numérique de la classe B est conforme à la norme NMB-003 du Canada.

8.3 Cabling Infrastructure

Poorly or incorrectly installed network cabling can cause numerous problems in the RSP-9003 network. However small it may appear, a problem with network cabling can have a catastrophic effect on the operation of the network. Even a small kink in a cable can cause an RSP to have intermittent connection with the RFID Gateway, and a poorly crimped connector may compromise Power over Ethernet (POE) functionality.

If there is existing cabling in an installation, it should be tested first using a Fluke Networks LSPRNTR-100 or equivalent device to insure proper RJ-45 connector pin out and Power over Ethernet (POE) capability before using with to power an RSP.

8.3.1 Correct Wiring Standards

There are two wiring standards for network cabling: T568a and T568b. **DO NOT COMBINE** T568a and T568b on the same cable!

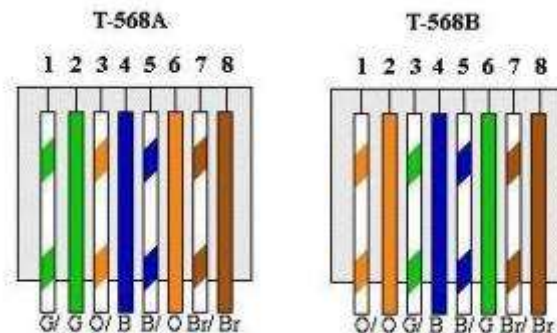

Figure 9 T-568A vs. T-568B

RJ-45 connectors are designed for either stranded or solid cable, but usually not both. Ensure use of the correct crimping tool for the specific type of connector. Ethernet cables have four pairs of color-coded twisted wires (orange, green, blue and brown). These cables are designed for high-speed data transfer with very little cross talk. It is important that no more than about 6 mm of the cable is untwisted at either end.

8.3.2 Proper Cable Type

For in-store RSP installations, it is recommended to use high-quality CAT 5e or CAT 6 cabling. Cables are categorized according to the data rates that they can transmit effectively. The specifications also describe the material, the connectors and the number of times each pair is twisted per meter. The most widely installed category is CAT 5e. Ensure that the category (CAT) of cabling used in the RFID system installation fulfills the required data rates.

- Cat 3 (no longer used) up to 16 MHz
- Cat 5e up to 100 MHz
- Cat 6 up to 250 MHz
- Cat 6A up to 500 MHz
- Cat 7 up to 600 MHz
- Cat 7A up to 1 GHz

Video and image files are generally much larger than JSON text files and need to be moved around the network as quickly as possible. In general, it is possible to use good-quality CAT 5 cabling for gigabit networks. However, it is generally recommended to use CAT 5e or CAT 6 cabling for gigabit connectivity, even if the existing network switches and routers support only 100 Mbps. This will ensure that the infrastructure in place can support gigabit data rates when an upgrade becomes necessary.

8.3.3 Proper Cable Length

Ensure that your cabling meets the requirements of your equipment. The distance between an RSP and the switch cannot be greater than 100 m. If installing sockets, remember to consider the distance between the socket and the RSP. A good rule of thumb is 90 meters for horizontal runs, and ten meters for the patch cabling. Do **NOT** run cabling next to electrical cabling due to the potential for interference.

Since network cabling typically uses solid wire, cabling should not be twisted or bent into a tight radius (not less than 4 times the diameter of the cable). Do not use metal staples to secure cable runs, nor tightly adjusted cable wraps.

Avoid a daisy chain network topology using intermediate switches or butt connectors to extend the length of an otherwise "too short" cable run. Use a single continuous cable run from the RSP to the switch.

8.3.4 Environmental Conditions

The RSP-9003 is designed to operate at 100% transmit duty-cycle in ambient temperature conditions of up to 50 C provided there is airflow across the back plate of the device. The RSP can also operate at 100% transmit duty-cycle in ambient temperature conditions of up to 35 C when mounted with the back-plate flush against a horizontal surface.

The RSP-9003 can operate at higher ambient temperature conditions by autonomously controlling the transmit duty-cycle. However, once the internal microprocessor reaches a temperature of 104 C, the RSP software will shut down to prevent damage and memory corruption.

8.3.5 Power over Ethernet

Power over Ethernet (POE) is a mechanism for supplying power to network devices over the same cabling used to carry network traffic. POE allows the RSP to receive both power and data over a single cable. This feature simplifies network installation and maintenance by using an Ethernet switch with integrated POE as a central power source for all RSPs. The challenge during installation is to calculate the total power consumption required making sure it is less than the power budget of the Ethernet switch. The Juniper EX2200-24P-4G is a recommended switch for RSP networks due to its remote manageability and sufficient 400W power budget to provide POE for an RSP on each of the 24 ports. However, any 48V POE+ switch is sufficient.

8.4 Connectivity

8.4.1 Physical

Figure 10 shows all the physical components of an in-store RFID network deployment and how they would be connected to one another.

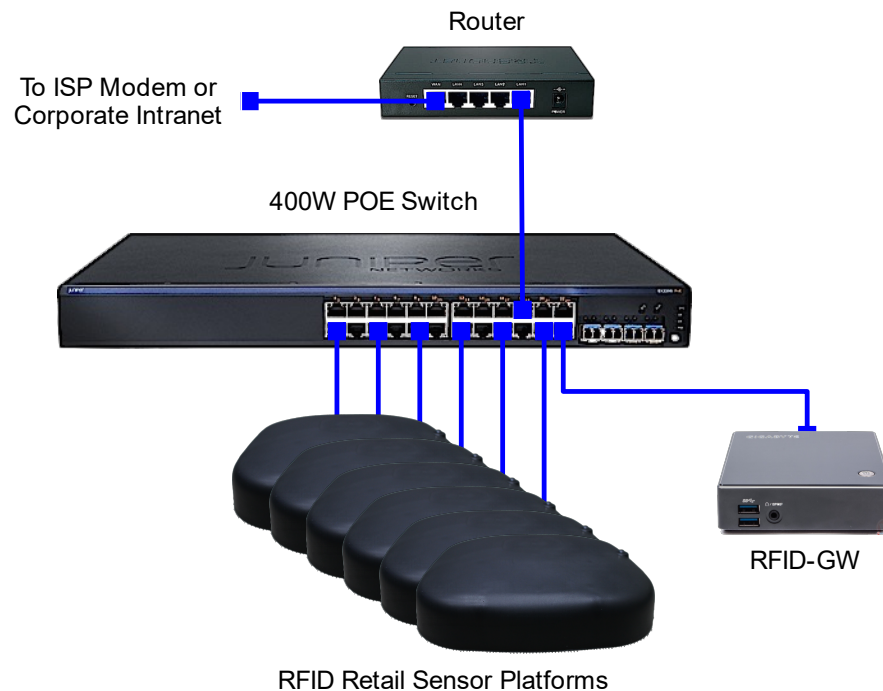

Figure 10 Physical In-Store Connectivity

8.4.2 Network Diagram

Prior to installation, make sure to notify the local corporate IT department that certain firewall rules may be necessary for proper functionality of the system. In addition to a more traditional network diagram, Figure 11 shows a list of domains, protocols and ports that the RSP requires access to for proper functionality of the system.

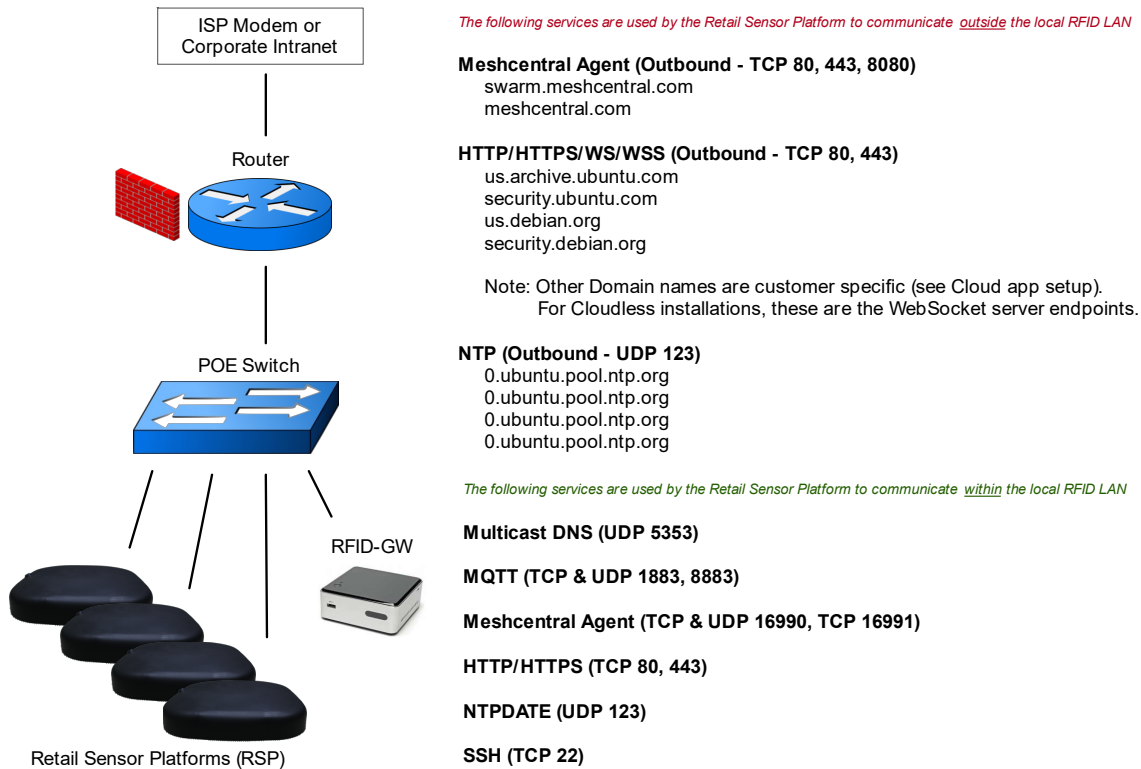

Figure 11 Network Diagram and Firewall Rules

8.5 Mounting

The typical Retail RFID installation will require the RSP sensors to be mounted from the ceiling. A common mounting technique is to utilize existing track-light rails. Figure 12 and Figure 13 show how the RSP can blend in with the actual lights mounted to the same rail.



Figure 12 Black Track Light Mounted RSP



Figure 13 White Track Light Mounted RSP

8.5.1 Track Light Mounting Bracket

Encinitas Labs provides a mounting bracket that allows the SENSOR to be mounted from a track light rail. (see Figure 14)

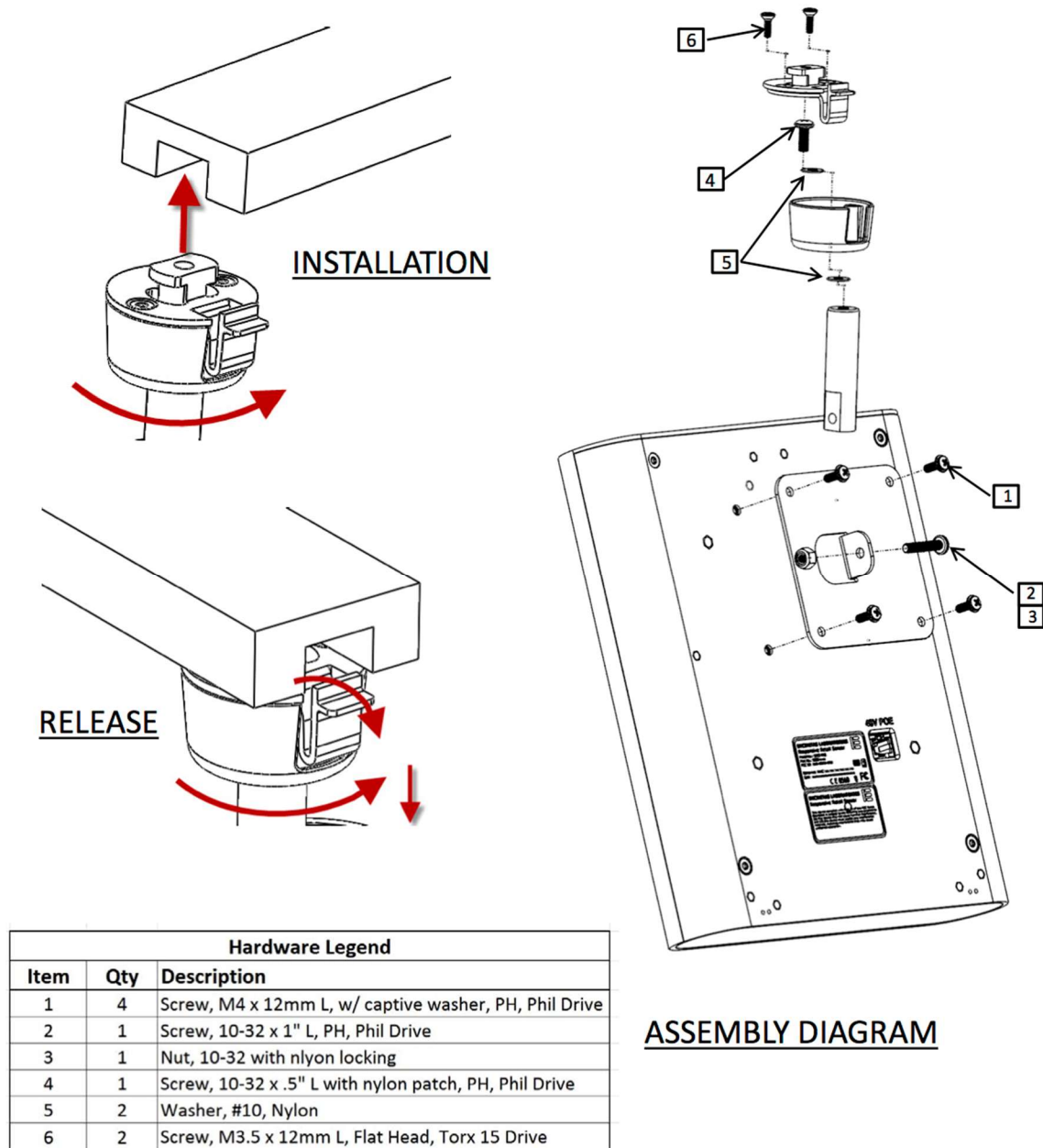
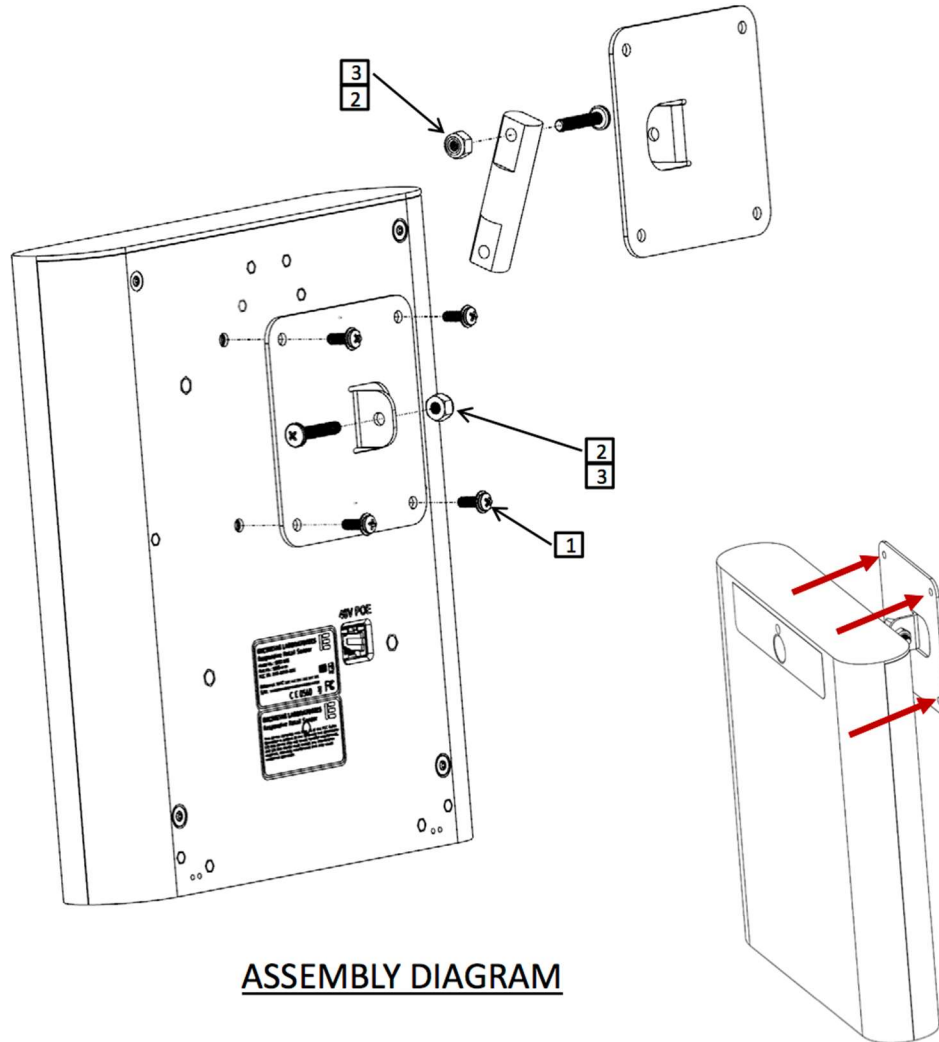

Figure 14 Track Light Assembly

8.5.2 Wall Mounting Bracket

Encinitas Labs provides a mounting bracket that allows the sensor to be mounted to a flat surface (see Figure 15).



ASSEMBLY DIAGRAM

Hardware Legend		
Item	Qty	Description
1	4	Screw, M4 x 12mm L, w/ captive washer, PH, Phil Drive
2	2	Screw, 10-32 x 1" L, PH, Phil Drive
3	2	Nut, 10-32 with nylon locking

Install onto mounting surface using Customer supplied hardware, 4x.

Figure 15 RSP Wall Mount Assembly

9 Command Line Interface (CLI) Support

The RSP-9003 and RSP-9800 are headless appliances designed to accept commands and configuration from the Gateway or Cloud Management Console application. For test and debug purposes, the base functionality for all the commands exposed in the Gateway API can be issued via a local Command Line Interface (CLI) session. Even when being controlled by the Retail Gateway, the CLI is a useful tool for debugging an monitoring key parameters during Gateway operation.

The example below shows how to log into the RFID Sensor Platform CLI using Windows PuTTY or other Unix like shell environment. The hostname of the RSP follows the format “RSP-xxxyzz” where xx:yy:zz are the last three octets of the RSP Ethernet MAC address. The **highlighted** text identifies what the user must type.

```
> ssh -p 62939 root@RSP-123456.local
> root@rsp-123456.local's password: itsallabouttheE!
root@rsp-123456:~#
root@RSP-123456:~# service rfid-rsp stop
Stopping service rfid-rsp...
root@RSP-123456:~# cd /opt/rfid-rsp/
root@RSP-123456:/opt/rfid-rsp#
root@RSP-123456:/opt/rfid-rsp# ./bin/rfid-rsp console
--
-- Retail Sensor
-- Version 1.2.3 built at 05/18/2017 16:28:56
--
-- Starting...
--

Retail Sensor Console Session

<tab> to view available commands
'clear' to clear the screen/console
'quit' to end

rfid-rsp>
```

Pressing the <tab> key at any point will present the user with the currently available commands or command options. After entering one of the choices, press the <tab> key again to see additional options or press <enter> to execute the command.

Pressing the <enter> key at any point prior to entering a complete command will provide either a general help screen or specific usage information regarding a partially entered command.

9.1 Top Level

```

rfid-rsp> <tab>
quit          rfid.protocol      rfid.select          log                rfid.radio
led           version                ssl                  rsp                tags
system        rfid.test              rfid.platform        rfid.query
  
```

9.2 RFID Protocol Commands

```

rfid-rsp> rfid.protocol <tab>
inventory     read                write                lock                kill
get           set                 cancel               pause
read.provisioning.tag  resume             write.provisioning.tag
  
```

```

rfid-rsp> rfid.protocol <enter>
-----
USAGE

> inventory
  Perform a tag inventory on all tags of interest
  rfid.protocol inventory <select> <post-match> <filter-dups> <auto-repeat> <delay_time>

> read
  Perform a tag read from the specified location on all tags of interest
  rfid.protocol read <select> <post-match> <bank> <word-offset> <word-count> <retries>

> write
  Perform a tag write to the specified location on all tags of interest
  The data must be in hexadecimal format (i.e. 0x123456789abcdef0)
  rfid.protocol write <select> <post-match> <bank> <word-offset> <word-count> <retries> <data>

> lock
  Perform a tag lock operation on all tags of interest
  rfid.protocol lock <select> <post-match> <killPerm> <AccPerm> <epcPerm> <tidPerm> <usrPerm> <retries>

> kill
  Perform a tag lock operation on all tags of interest
  rfid.protocol kill <select> <post-match> <retries> <killPass>

> get or set password
  Configure the Access or Kill Password
  rfid.protocol get password <type>
  rfid.protocol set password <type> <password>

> pause
  Temporarily pause the protocol operation in progress
  rfid.protocol pause

> resume
  Resume the protocol operation in progress
  rfid.protocol resume

> cancel
  Cancel the protocol operation in progress
  rfid.protocol cancel

> read.provisioning.tag
  Read the contents of a Provisioning Tag given the EPC
  rfid.protocol read.provisioning.tag <epc>

> write.provisioning.tag
  Write the contents of a Provisioning Tag given the EPC, Root Cert SHA256 and Token
  rfid.protocol write.provisioning.tag <epc> <sha256> <token>
  
```

9.3 RFID Select Commands

```
rfid-rsp> rfid.select <tab>
get          set

rfid-rsp> rfid.select <enter>
-----
USAGE

> get or set select.criteria
  The Tag Select Criteria Configuration
  Tag Select is a pre-singulation activity. The RSP can support up to eight
  sets of tag Select Criteria. Each set of criteria defines a bitmask to match
  against the location defined in the specified memory bank. The <action> and
  any tag protocol operation is applied to any and all tags that match the mask.
  If the mask is entered as a hexadecimal value, it must be preceded by 0x (i.e. 0xab56
  rfid.select get select.criteria <index>
  rfid.select set select.criteria <state> <bank> <session> <action> <offset> <count> <mask> <index>

> get or set post.match.criteria
  The Post Singulation Match Criteria Configuration
  This criteria defines a bitmask and location to match against the EPC memory bank.
  Any tag protocol operation is applied either Inclusively or Exclusively.
  If the mask is entered as a hexadecimal value, it must be preceded by 0x (i.e. 0xab56
  rfid.select get post.match.criteria
  rfid.select set post.match.criteria <match> <offset> <count> <mask>
```

9.4 Log Commands

```
rfid-rsp> log <tab>
show          set
rfid-rsp> log <enter>
-----
USAGE

> log show
  Shows the current log level settings for all active loggers

> log set <log id> <level>
  Sets the level of the logger associated with the log_id
```

9.5 RFID Radio Commands

```
rfid-rsp> rfid.radio <tab>
get          set

rfid-rsp> rfid.radio <enter>
-----
USAGE

> get or set freq.plan
  The Embedded RFID Module Regional Frequency Plan
  rfid.radio get freq.plan
  rfid.radio set freq.plan <FreqPlan>

> get or set operation.mode
  The Inventory Mode of operation (Continuous/NonContinuous)
  rfid.radio get operation.mode
  rfid.radio set operation.mode <OpMode>

> get or set link.profile
  The Profile that defines Modulation Type, Tari, Data Rate and Coding
  rfid.radio get link.profile
  rfid.radio set link.profile <0 - 3>

> get or set port.config
  The Virtual Port Configuration
  An Inventory Round consists of performing one or more Inventory Cycles
  on each enabled virtual antenna port. The number of Inventory Cycles executed
  can be fixed by setting <invCycles> to a non-zero value. The amount of time
  spent on each virtual port can be deterministic by setting <dwelTime> to a
  non-zero value.
  rfid.radio get port.config <index>
  rfid.radio set port.config <state> <power (dBm)> <dwelTime (ms)> <invCycles (ms)> <pPort> <index>

> set default.values
  Load the RFID default values specified in rfid.properties
  rfid.radio set default.values
```

9.6 LED Commands

```
rfid-rsp> led <tab>
set.color.mode      set.state      clear          notify

rfid-rsp> led <enter>
-----
USAGE

> led set.color.mode
  Change the color of the visual indicator
  led set.color.mode <color> <mode>
  Color: [White, Red, Green, Blue, Yellow, Magenta, Cyan, Black]
  Mode: [Off, Constant, BlinkOnce, SlowBlink, MediumBlink, FastBlink, Roll]

> led set.state
  Change the macro state of the visual indicator
  led set.state <state>
  State: [Alert, Beacon, Disabled, Normal, Test]

> led notify
  Cause the LED to display the notification for the state
  led notify <stats>
  State: [gw.discovery, provision.tag, provision.tag.complete, alert]

> led clear
  Clear the LED notification for the state
  led clear <state>
  State: [gw.discovery, provision.tag, provision.tag.complete, alert]
```

9.7 Version Commands

```
rfid-rsp> version <tab>
info

rfid-rsp> version <enter>
-----
USAGE

> version info
  Displays the software version information
```

9.8 SSL Commands

```
rfid-rsp> ssl <tab>
info      retrieve.json.cert      cert.detail      delete.cert      load.json.cert

rfid-rsp> ssl <enter>
-----
USAGE

> ssl info
  Displays summary information about certificates

> ssl cert.detail <alias>
  Displays certificate associated with the alias

> ssl load.json.cert <alias> <full path to file>
  Loads the certificate from the file
  must be in Base64 encoded one line pem format (Json Certificate API)

> ssl retrieve.json.cert <url>
  Retrieves the json certificate from the url and stores the certificate
  using the url for the alias

> ssl delete.cert <alias>
  Deletes the certificate associated with the alias
```



9.9 RSP Commands

```
rfid-rsp> rsp <tab>  
ack.alerts      enter.maintenance.mode      exit.maintenance.mode      restart      log.motion.events
```

```
rfid-rsp> rsp <enter>
```

USAGE

- > rsp ack.alerts
Displays and acknowledges current alerts
 - > rsp enter.maintenance.mode
Disconnect from the gateway to allow complete local control
 - > rsp exit.maintenance.mode
Reconnects to the gateway
 - > rsp restart
restarts the sensor platform
 - > rsp log.motion.events <true,false>
Enables or disables logging of motion events
-

9.10 Tag Commands

```
rfid-rsp> tags <tab>  
show.detail      show.summary      unload.database
```

```
rfid-rsp> tags <enter>
```

USAGE

- > show.summary
Displays a summary of the local tag database
tags show.summary
 - > show.detail
Displays tag database details
tags show.detail
 - > unload.database
Flushes the contents of the local tag database
tags unload.database
-

9.11 System Commands

```
rfid-rsp> system <tab>  
info
```

```
rfid-rsp> system <enter>
```

USAGE

- > system info
Displays processor and memory information
-

9.12 RFID Test Commands

```
rfid-rsp> rfid.test <tab>
get          set          band.scan      cw          random.data    reset.module
reset.radio
```

```
rfid-rsp> rfid.test <enter>
```

USAGE

USAGE

```
> get rf.power
  Retrieve the current Forward and Reverse Power
  rfid.test get rf.power

> get pa.temp
  Retrieve the current PA Temperature
  rfid.test get pa.temp

> get mac.error
  Retrieve the last RFID Module Error Code
  rfid.test get mac.error

> set mac.command
  Execute a specific R2000 MAC Command
  rfid.test set mac.command <command> <sub-command>

> get or set ant.sense.thresh
  The resistance, specified in ohms, above which the antenna-sense resistance
  should be considered to be an open circuit
  rfid.test get ant.sense.thresh

> get or set config
  The Test Mode Antenna Port Configuration
  rfid.test get config
  rfid.test set config <freq(kHz)> <power(dBm)> <port>

> get or set register
  Access the set of 32-bit firmware registers within the RFID Module
  rfid.test get register <type> <16-bit address>
  rfid.test set register <type> <16-bit address> <32-bit data>

> cw
  Turn on or off a CW tone on the configured test port
  rfid.test cw <boolean>

> random.data
  Turn on or off random data on the configured test port
  rfid.test random.data <boolean>

> band.scan
  Turn on or off a band scan on the configured test port (CURRENTLY NOT SUPPORTED)
  rfid.test band.scan <boolean>

> reset.radio
  Perform a reset of the embedded RFID module
  rfid.test reset.radio

> reset.module
  Perform a reset of the Smart Antenna application
  rfid.test reset.module

-----
```

9.13 RFID Platform Commands

```

rfid-rsp> rfid.platform <tab>
get          set          format.oem      load.file

rfid-rsp> rfid.platform <enter>
-----
USAGE

> get or set device.id
  The ID of the Embedded RFID Module is an integer 0 - 255
  rfid.platform get device.id
  rfid.platform set device.id <id>

> get firmware.version
  Show the current RFID Module firmware version
  rfid.platform get firmware.version

> get or set gpio.config
  The direction of the RFID Module remote GPIO
  rfid.platform get gpio.config
  rfid.platform set gpio.config <bitmask> <direction>

> get or set gpio
  The value of the RFID Module remote GPIO
  rfid.platform get gpio <bitmask>
  rfid.platform set gpio <bitmask> <value>

> get or set oem.config data
  Access the set of OEM config items within the RFID Module
  rfid.platform get oem.config <OEMCFG type>
  rfid.platform set oem.config <OEMCFG type> <32-bit value>

> format.oem data
  Format the OEM Configuration space back to default values
  rfid.platform format.oem <region> <listen-before-talk>

> load.file oem.config filename
  Access the set of OEM config items within the RFID Module
  rfid.platform load.file oem.config <full path to file>

> load.file firmware.update filename
  Update the RFID Module firmware image
  rfid.platform load.file firmware.update <test> <full path to file>

```

9.14 RFID Query Commands

```

rfid-rsp> rfid.query <tab>
get          set

rfid-rsp> rfid.query <enter>
-----
USAGE

> get or set tag.group
  The Tag Query Group Configuration
  This configuration defines which group of tags will execute a protocol operation
  by defining what state their select and session flags must be in.
  rfid.query get tag.group
  rfid.query set tag.group <SL state> <session flag> <target state>

> get or set q.algorithm
  The Q Algorithm Configuration
  This configuration defines which singulation algorithm is to be used.
  rfid.query get q.algorithm
  rfid.query set q.algorithm <algorithm>

> get or set fixed.params
  The Fixed Q Algorithm Configuration
  These parameters define the Fixed Q Algorithm behavior.
  rfid.query get fixed.params
  rfid.query set fixed.params <toggle> <repeat> <qValue> <retries>

> get or set dynamic.params
  The Dynamic Q Algorithm Configuration
  These parameters define the Dynamic Q Algorithm behavior.
  rfid.query get dynamic.params
  rfid.query set dynamic.params <toggle> <startQ> <minQ> <maxQ> <adj> <retries>

```