

标记	人数	更改内容	签字	日期

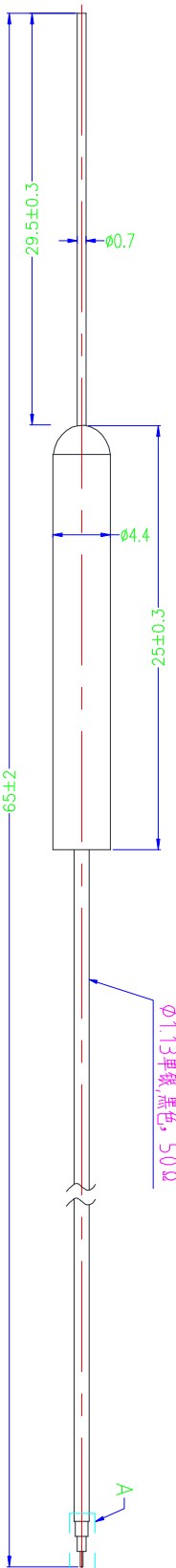

规格说明:
 1. 频率范围: 2.4GHz-2.5GHz;
 2. 功率增益: 2.0dBi.

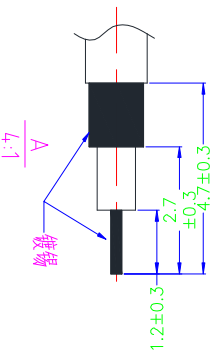

TITLE: 2.4G铜管天线		MATERIAL: ??		FINISH: 表面处理	
PART/NO.: C113H-BT44-29.5-65R		TOLERANCE ??		ANGULAR??	
UNIT IN mm		SCALE: 2.5:1		X.XX ±0.1°	
DRAWING 散		DATE 17-06-25		X.X ±0.2°	
CHECKING ??		DATE ??		SPECIFIED	
REV 01		次数			

东莞市利信威电子有限公司

Product Specification

A. Electrical Characteristics

Frequency 2400MHz ~2500MHz

VSWR <2.0

Efficiency >70%

Impedance 50 Ohm

Polarization Line

Gain 2DBi

B. Material & Mechanical Characteristics

Material of Radiator Cu

Cable Type 1.13 黑色

Connector Type : NO

Dimension

C. Environmental

Operation Temperature - 30 °C ~ + 80 °C

Storage Temperature - 30 °C ~ + 85 °C

Test Equipment & Conditions

1. Network Analyzers :

Agilent 8753D 5071B

2. Communications Test Set:

Agilent E5515C

3. 3D Chamber Test System

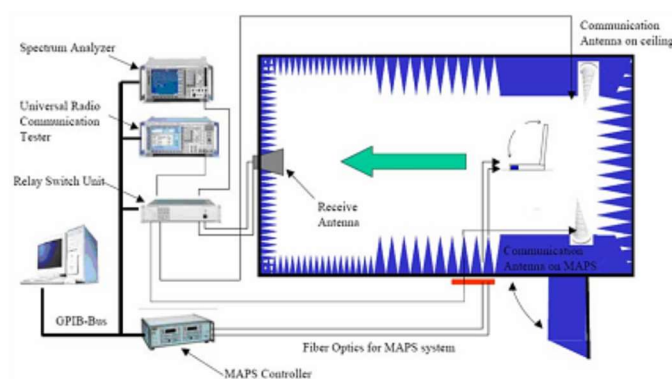

(Testing by 3D anechoic chamber)

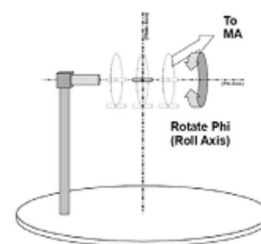

Phi axis test

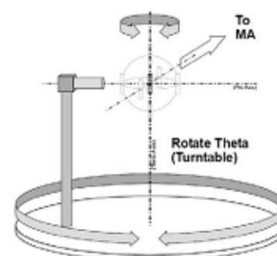

Theta axis test

Efficiency & Gain

Freq (MHz)	Effi (%)	Gain (dBi)
2400	76.45	2.32
2410	74.46	2.45
2420	74.38	2.83
2430	72.39	2.86
2440	66.29	2.43
2450	72.10	2.63
2460	71.65	2.69
2470	72.76	2.81
2480	72.42	2.60
2490	68.33	2.65
2500	67.49	2.29

S11

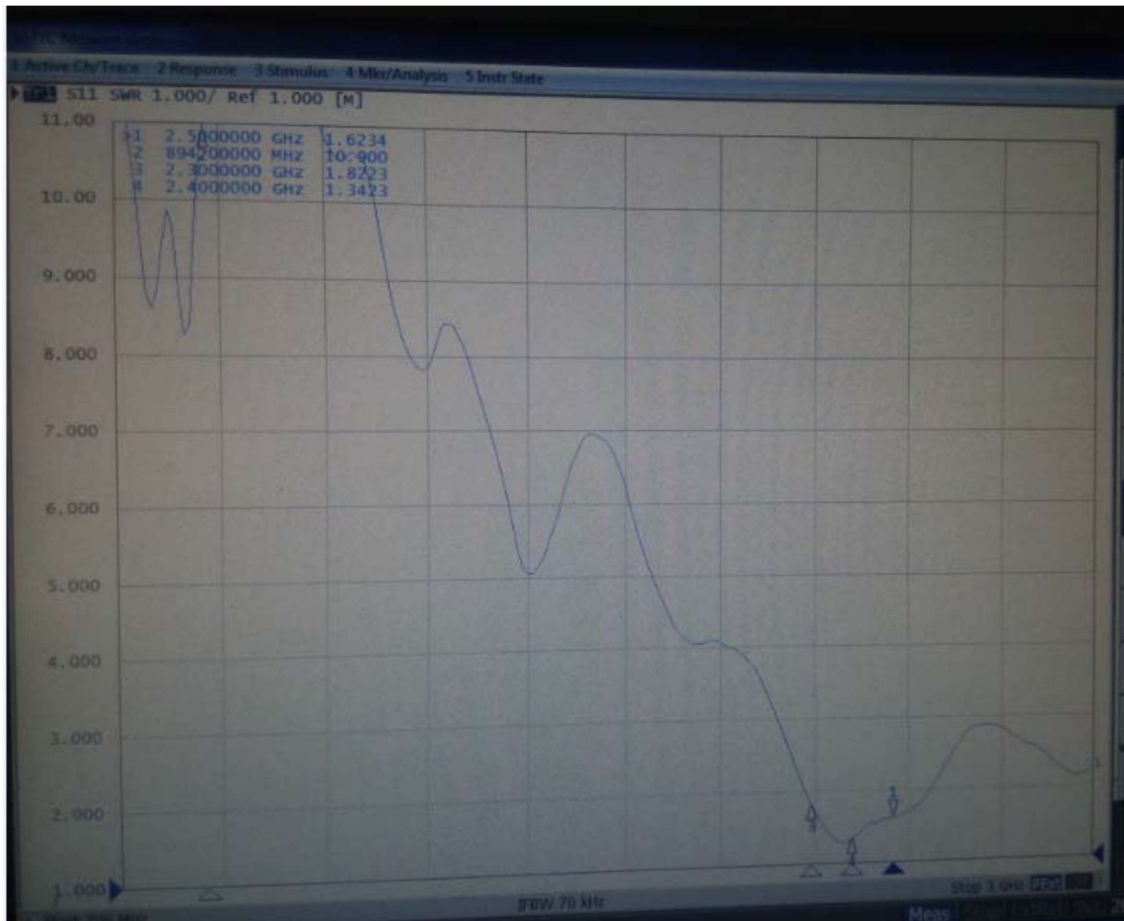

Radiation Pattern:

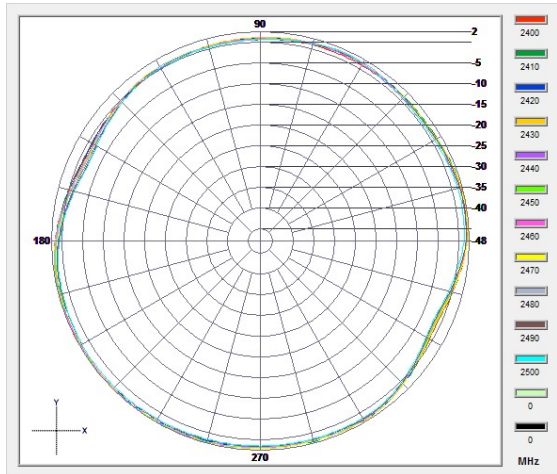

XY

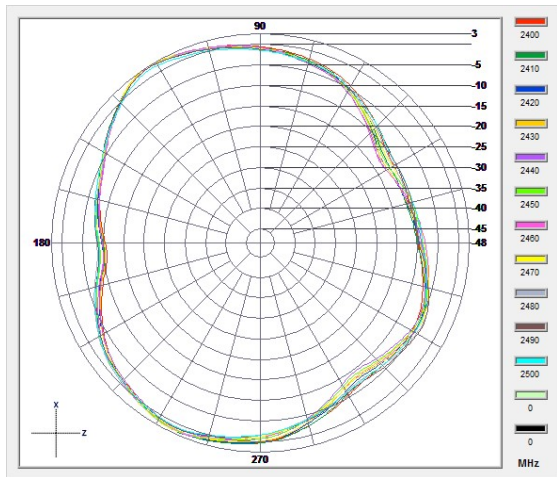

XZ

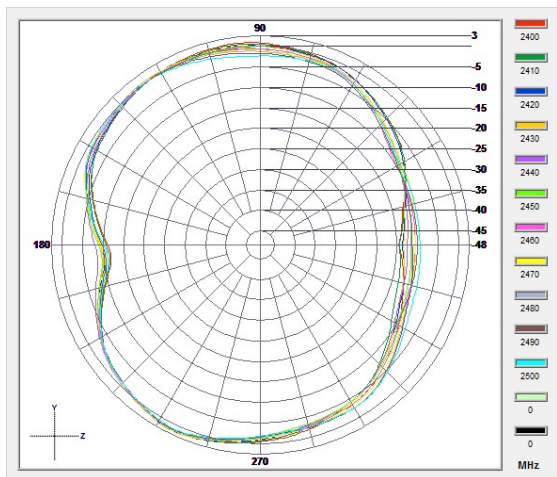

YZ

2400 2410 2420 2430 2440 2450 2460 2470 2480 2490 2500

