

FCC RADIO TEST REPORT

For

FCC ID: 2ALTXTFMTKAW01216

Report Reference No..... : 18EFAS10049 31
Date of issue..... : 2018-10-15
Testing Laboratory..... : DongGuan ShuoXin Electronic Technology Co., Ltd.
Address..... : Zone A, 1F, No. 6, XinGang Road YuanGang Street, XinAn
District, ChangAn Town, DongGuan City, GuangDong,
China
Applicant's name : TrekStor GmbH
Address..... : Berliner Ring 7, 64625 Bensheim, Germany
Manufacturer..... : Heyuan Vastking Electronic Co., Ltd.
Test specification:
Test item description..... : TrekStor SurfTab theatre K13
Trade Mark : TREKSTOR
Model/Type reference : TFMTKAW01216
Ratings..... : INPUT: 100-240V~ 50/60HZ 0.45A, OUTPUT: DC5V 3A
DC 3.8V 10000mAh Li-polymer Battery

Responsible Engineer :

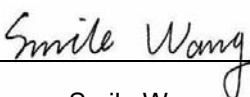
Smile Wang

Authorized Signatory:

King Wang

TABLE OF CONTENTS

1.	Summary of test results	4
2.	General test information	5
2.1.	Description of EUT	5
2.2.	Accessories of EUT	6
2.3.	Assistant equipment used for test.....	6
2.4.	Block diagram of EUT configuration for test	7
2.5.	Test environment conditions.....	7
2.6.	Test environment conditions.....	8
2.7.	Measurement uncertainty	8
3.	POWER SPECTRAL DENSITY TEST	9
3.1.	Test equipment.....	9
3.2.	Block diagram of test setup	9
3.3.	Applied procedures / limit	9
3.4.	Test Procedure	10
3.5.	Test Result	11
4.	26 dB & 99% Emission Bandwidth	21
4.1.	Test equipment.....	21
4.2.	Block diagram of test setup	21
4.3.	Applied procedures / limit	21
4.4.	Test Procedure	21
4.5.	Test Result	22
5.	MAXIMUM CONDUCTED OUTPUT POWER	39
5.1.	Test Result	40
6.	Band Edges Measurement	41
6.1.	Test Result	43
7.	RADIATED EMISSION MEASUREMENT	47
7.1.	Test equipment.....	47
7.2.	Block diagram of test setup	48
7.3.	Limit.....	50
7.4.	Test Procedure	51
7.5.	Test result(Below 30MHz)	53
8.	FREQUENCY STABILITY	59
	Power Line Conducted Emission.....	63
9.1	Test equipment.....	63
9.2	Block diagram of test setup	63
9.3	Power Line Conducted Emission Limits(Class B).....	63

9.5 Test Result	64
9. Antenna Requirements	67
9.1. Limit	67
9.2. EUT ANTENNA	67

TEST REPORT DECLARE

Applicant	:	TrekStor GmbH
Address	:	Berliner Ring 7, 64625 Bensheim, Germany
Equipment under Test	:	TrekStor SurfTab theatre K13
Model No	:	TFMTKAW01216
Trade Mark	:	TREKSTOR
Manufacturer	:	Heyuan Vastking Electronic Co., Ltd.
Address	:	No.13, Hepu Avenue, Yuancheng District, Heyuan City, Guangdong

Test Standard Used: FCC Part 15E 15.407

Test procedure used: ANSI C63.10-2013 and KDB 789033 D02 General UNII Test Procedures New Rules v02r01 .

We Declare:

The equipment described above is tested by DongGuan ShuoXin Electronic Technology Co., Ltd. and in the configuration tested the equipment complied with the standards specified above. The test results are contained in this test report and DongGuan ShuoXin Electronic Technology Co., Ltd. is assumed of full responsibility for the accuracy and completeness of these tests.

After test and evaluation, our opinion is that the equipment provided for test compliance with the requirement of the above FCC standards.

Report No:			
Date of Test:	2018-10-15	Date of Report:	2018-10-19

Note: This report applies to above tested sample only. This report shall not be reproduced in parts without written approval of DongGuan ShuoXin Electronic Technology Co., Ltd.

1. SUMMARY OF TEST RESULTS

The EUT have been tested according to the applicable standards as referenced below.		
FCC Part15 (15.407) , Subpart E		
Description of Test Item	Standard	Results
AC Power Line Conducted Emissions	FCC §15.207/ RSS-Gen	PASS
Spurious Radiated Emissions	FCC §15.209(a), 15.407(b)	PASS
26 dB and 99% Emission Bandwidth	FCC §15.407(a)	PASS
Maximum Conducted Output Power	FCC §407(a)(1)	PASS
Band Edges	FCC §2.1051, §15.407(b)	PASS
Power Spectral Density	FCC §15.407(a)(1)	PASS
Spurious Emissions at Antenna Terminals	FCC §2.1051, §15.407(b)	PASS
Frequency Stability	FCC §15.407(a)(6)	PASS
Antenna Requirement	FCC §15.203	PASS

2. GENERAL TEST INFORMATION

2.1. DESCRIPTION OF EUT

EUT* Name	:	TrekStor SurfTab theatre K13
Model Number	:	TFMTKAW01216
EUT function description	:	TrekStor SurfTab theatre K13 with WiFi & BT function.
Power supply	:	INPUT: 100-240V~ 50/60HZ 0.45A, OUTPUT: DC5V 3A DC 3.8V 10000mAh Li-polymer Battery
Adaptor	:	JHD-AP015U-050300BA-C
Operation frequency	:	WiFi: 802.11a/802.11n(HT20) /ac(VHT20): 5180MHz ~ 5240MHz; 802.11n(HT40)/ac(VHT40): 5190MHz ~ 5230MHz
Modulation	:	OFDM with OFDM, BPSK, QPSK, 16QAM, 64QAM for 802.11a/n/ac;
Data Rate	:	802.11 a: 6,9,12,18,24,36,48,54Mbps; 802.11n(HT20):MCS0-MCS7; 802.11n(HT40): MCS0-MCS7; 802.11ac(HT20/HT40):Up to 650Mbps
Antenna Type	:	FPCB antenna
Battery	:	DC 3.8V 10000mAh
Date of Receipt	:	2018/10/19
Sample Type	:	N/A

UNII-1		UNII-1		UNII-1	
Channel	Frequency (MHz)	Channel	Frequency (MHz)	Channel	Frequency (MHz)
36	5180	38	5190	42	5210
40	5200	46	5230		
44	5220				
48	5240				

2.2.ACCESSORIES OF EUT

Description of Accessories	Shielded Type	Ferrite Core	Length
Adapter	Shen Zhen Jihongda Power Co., Ltd	/	/

2.3.ASSISTANT EQUIPMENT USED FOR TEST

Description of Assistant equipment	Manufacturer	Model number or Type	EMC Compliance	SN
/	/	/	/	/

2.4. BLOCK DIAGRAM OF EUT CONFIGURATION FOR TEST



2.5. TEST ENVIRONMENT CONDITIONS

To investigate the maximum EMI emission characteristics generates from EUT, the test system was pre-scanning tested base on the consideration of following EUT operation mode or test configuration mode which possible have effect on EMI emission level. Each of these EUT operation mode(s) or test configuration mode(s) mentioned above was evaluated respectively.

Pretest Mode	Description
Mode 1	Link Mode
Mode 2	802.11a / n 20/ac20 CH36/ CH40/ CH48

For Radiated Emission	
Final Test Mode	Description
Mode 1	Link Mode
Mode 2	802.11a / n 20 CH36/ CH40/ CH48
Mode 3	802.11n40 CH38/ CH 46

Note:

- (1) The measurements are performed at the highest, middle, lowest available channels.
- (2) The measurements are performed at all Bit Rate of Transmitter, the worst data was reported

2.6. TEST ENVIRONMENT CONDITIONS

During the measurement the environmental conditions were within the listed ranges:

Temperature range:	21-25°C
Humidity range:	40-75%
Pressure range:	86-106kPa

2.7. MEASUREMENT UNCERTAINTY

Test Item	Uncertainty
Uncertainty for Conduction emission test (9kHz-150kHz)	3.7 dB
Uncertainty for Conduction emission test (150kHz-30MHz)	3.3 dB
Uncertainty for Radiation Emission test (30MHz-200MHz)	4.6 dB (Polarize: V)
	4.6 dB (Polarize: H)
Uncertainty for Radiation Emission test (200MHz-1GHz)	6.0 dB (Polarize: V)
	5.0 dB (Polarize: H)
Uncertainty for Radiation Emission test (1GHz-6GHz)	5.1 dB (Polarize: V)
	5.1 dB (Polarize: H)
Uncertainty for Radiation Emission test (6GHz-18GHz)	5.4 dB (Polarize: V)
	5.4 dB (Polarize: H)
Uncertainty for Radiation Emission test (18GHz-40GHz)	5.06 dB (Polarize: V)
	5.06 dB (Polarize: H)
Uncertainty for radio frequency	±0.048kHz
Uncertainty for conducted RF Power	±0.32dB

Note: This uncertainty represents an expanded uncertainty expressed at approximately the 95% confidence level using a coverage factor of k=2.

3. POWER SPECTRAL DENSITY TEST

3.1. TEST EQUIPMENT

Item	Equipment	Manufacturer	Model No.	Serial No.	Cal Due.	Cal. Interval
1	Spectrum analyzer	KEYSIGHT	N9010A	MY55150427	2019/05/25	1 Year
2	Attenuator	Mini-Circuits	BW-S10W2	101109	2018/12/17	1 Year
3	RF Cable	Micable	C10-01-01-1	100309	2018/12/17	1 Year
4	Spectrum analyzer	R&S	FSV40	101470	2019/06/28	1 Year

3.2. BLOCK DIAGRAM OF TEST SETUP

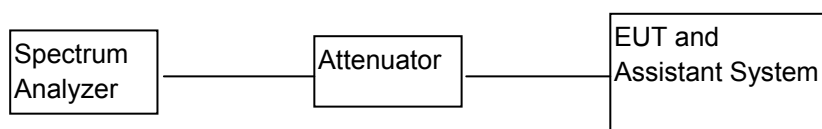

3.3. APPLIED PROCEDURES / LIMIT

According to FCC §15.407(a)(3)

For the band 5.15-5.25 GHz,

(i) For an outdoor access point operating in the band 5.15-5.25 GHz, the maximum power spectral density shall not exceed 17 dBm in any 1 megahertz band. If transmitting antennas of directional gain greater than 6 dBi are used, both the maximum conducted output power and the maximum power spectral density shall be reduced by the amount in dB that the directional gain of the antenna exceeds 6 dBi. The maximum e.i.r.p. at any elevation angle above 30 degrees as measured from the horizon must not exceed 125 mW (21 dBm).

(ii) For an indoor access point operating in the band 5.15-5.25 GHz, the maximum power spectral density shall not exceed 17 dBm in any 1 megahertz band. If transmitting antennas of directional gain greater than 6 dBi are used, both the maximum conducted output power and the maximum power spectral density shall be reduced by the amount in dB that the directional gain of the antenna exceeds 6 dBi.

(iii) For fixed point-to-point access points operating in the band 5.15-5.25 GHz, the maximum power spectral density shall not exceed 17 dBm in any 1 megahertz band. Fixed point-to-point U-NII devices may employ antennas with directional gain up to 23 dBi without any corresponding reduction in the maximum conducted output power or maximum power spectral density. For fixed point-to-point transmitters that employ a directional antenna gain greater than 23 dBi, a 1 dB reduction in maximum conducted output power and maximum power spectral density is required for each 1 dB of antenna gain in excess of 23 dBi. Fixed, point-to-point operations exclude the use of point-to-multipoint systems, omnidirectional applications, and multiple collocated transmitters transmitting the same information. The operator of the U-NII device, or if the equipment is professionally installed, the installer, is responsible for ensuring that systems employing high gain directional antennas are used exclusively for fixed, point-to-point operations.

(iv) For mobile and portable client devices in the 5.15-5.25 GHz band, the maximum power spectral density shall not exceed 11 dBm in any 1 megahertz band. If transmitting antennas of directional gain greater than 6 dBi are used, both the maximum conducted output power and the maximum power spectral density shall be reduced by the amount in dB that the directional gain of the antenna exceeds 6 dBi.

For the band 5.725-5.85 GHz
For the band 5.725-5.85 GHz, the maximum power spectral density shall not exceed 30 dBm in any 500-kHz band. If transmitting antennas of directional gain greater than 6 dBi are used, both the maximum conducted output power and the maximum power spectral density shall be reduced by the amount in dB that the directional gain of the antenna exceeds 6 dBi..

3.4. TEST PROCEDURE

(For devices operating in the bands 5.15-5.25 GHz, 5.25-5.35 GHz, and 5.47-5.725 GHz, the above procedures make use of 1 MHz RBW to satisfy directly the 1 MHz reference bandwidth specified in § 15.407(a)(5). For devices operating in the band 5.725-5.85 GHz, the rules specify a measurement bandwidth of 500 kHz. Many spectrum analyzers do not have 500 kHz RBW, thus a narrower RBW may need to be used. The rules permit the use of a RBWs less than 1 MHz, or 500 kHz, “provided that the measured power is integrated over the full reference bandwidth” to show the total power over the specified measurement bandwidth (i.e., 1 MHz, or 500 kHz). If measurements are performed using a reduced resolution bandwidth (< 1 MHz, or < 500 kHz) and integrated over 1 MHz, or 500 KHz bandwidth, the following adjustments to the procedures apply:

- a) Set $RBW \geq 1/T$, where T is defined in section II.B.I.a).
- b) Set $VBW \geq 3 RBW$.
- c) If measurement bandwidth of Maximum PSD is specified in 500 kHz, add $10\log(500\text{kHz}/RBW)$ to the measured result, whereas RBW (< 500 KHz) is the reduced resolution bandwidth of the spectrum analyzer set during measurement.
- d) If measurement bandwidth of Maximum PSD is specified in 1 MHz, add $10\log(1\text{MHz}/RBW)$ to the measured result, whereas RBW (< 1 MHz) is the reduced resolution bandwidth of spectrum analyzer set during measurement.
- e) Care must be taken to ensure that the measurements are performed during a period of continuous transmission or are corrected upward for duty cycle.

Note: As a practical matter, it is recommended to use reduced RBW of 100 KHz for the sections 5.c) and 5.d) above, since RBW=100 KHz is available on nearly all spectrum analyzers.

3.5. TEST RESULT

CH. No.	Frequency	Power Density (dBm/MHz)	total power density (dBm/MHz)	Limit (dBm/MHz)	Result
TX 802.11a Mode					
CH36	5180	-2.82	--	11	Pass
CH40	5200	-3.89	--	11	Pass
CH48	5240	-4.12	--	11	Pass
TX 802.11n20 Mode					
CH36	5180	-3.68	--	11	Pass
CH40	5200	-4.01	--	11	Pass
CH48	5240	-4.30	--	11	Pass
TX 802.11n40 Mode					
CH38	5190	-4.48	--	11	Pass
CH46	5230	-6.61	--	11	Pass

CH. No.	Frequency	Power Density (dBm/MHz)	total power density (dBm/MHz)	Limit (dBm/MHz)	Result
TX 802.11 ac(VHT20) Mode					
CH36	5180	-2.94	--	11	Pass
CH40	5200	-3.17	--	11	Pass
CH48	5240	-3.21	--	11	Pass
TX 802.11 ac(VHT40) Mode					
CH38	5190	-5.79	--	11	Pass
CH46	5230	-6.78	--	11	Pass

Test plots as followed:

802.11a
Channel: 36

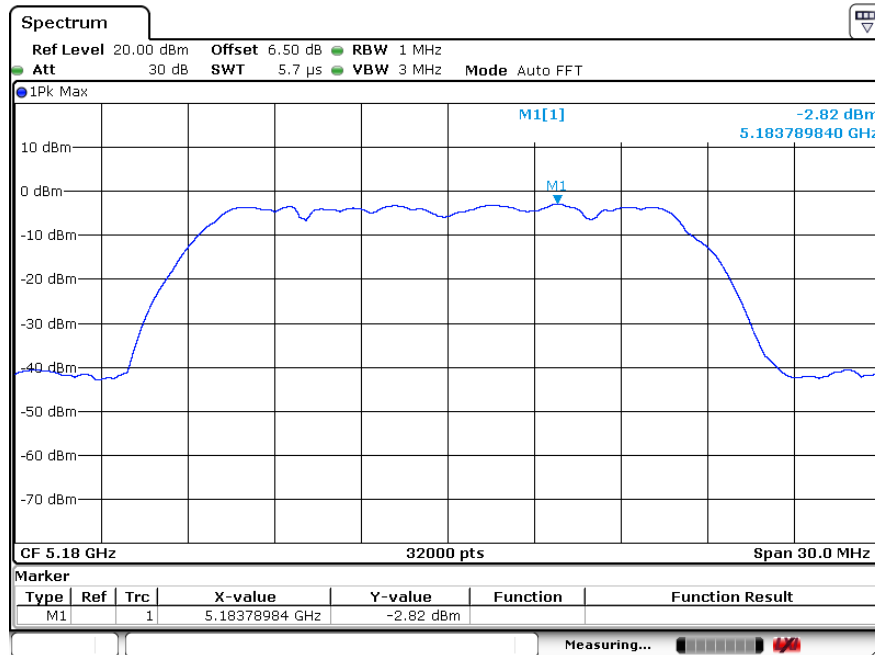

Channel: 40

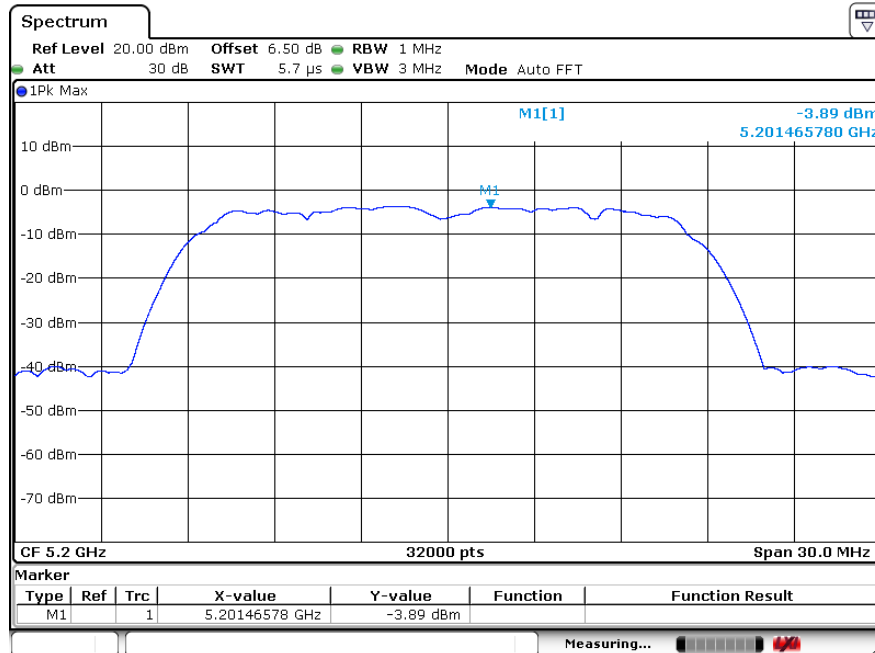

Channel: 48

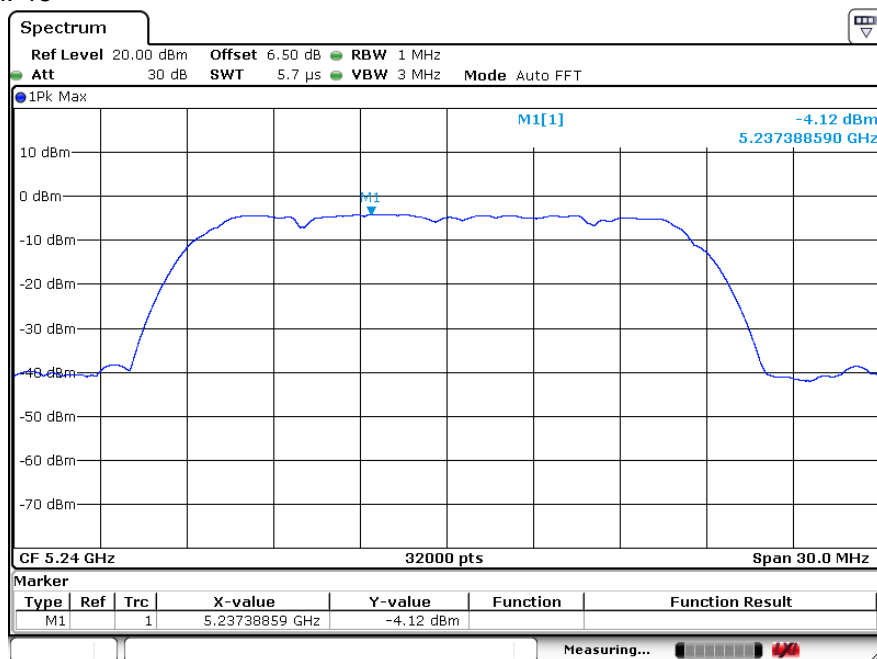

802.11n20 Channel: 36

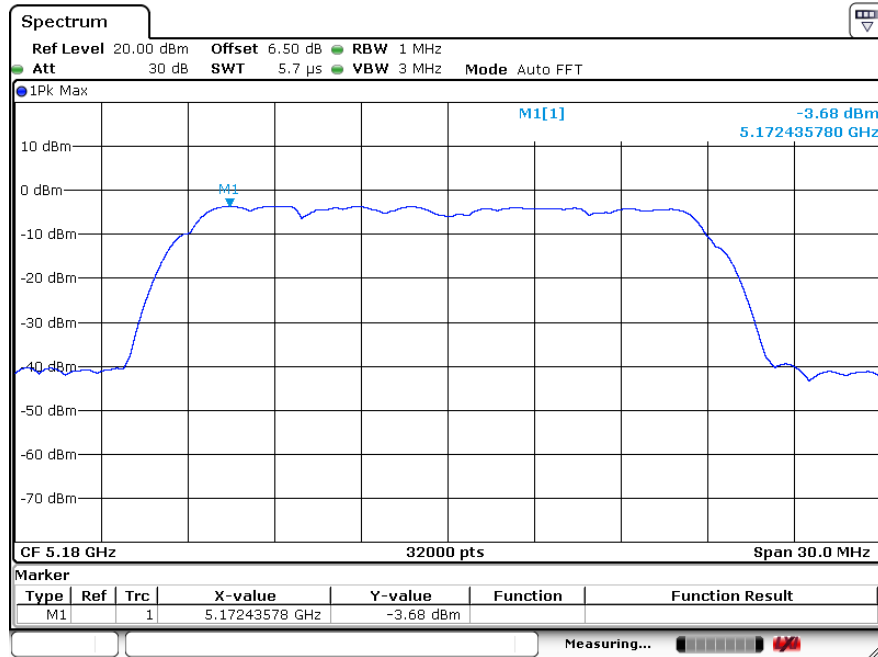

Channel: 40

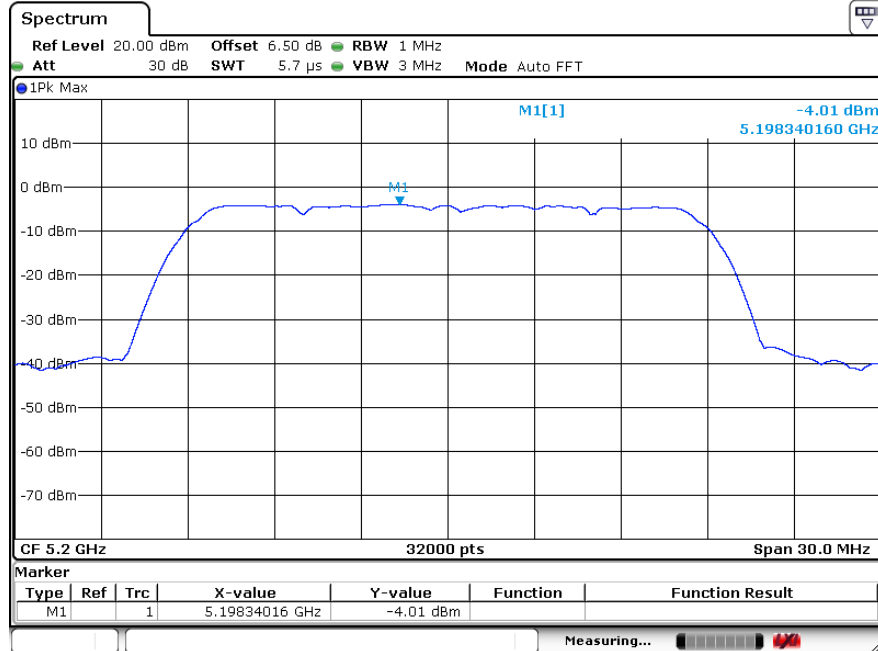

Channel: 48

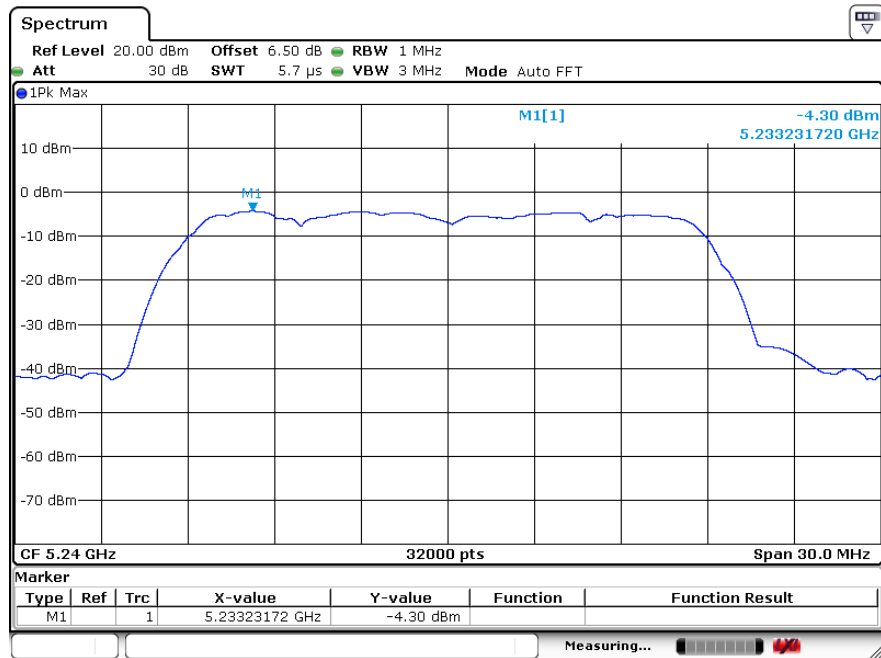

802.11ac20 Channel: 36

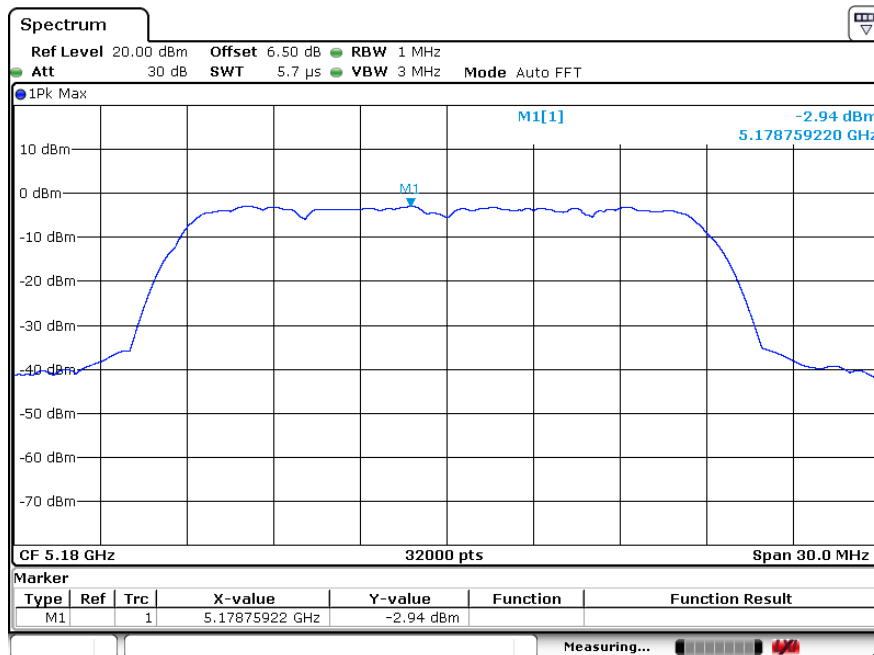

Channel: 40

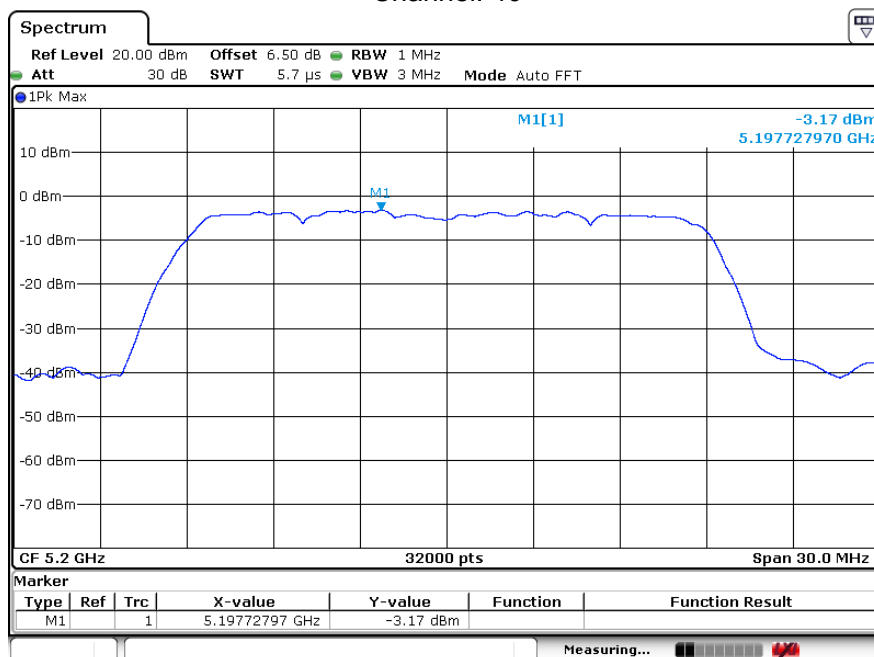

Channel: 48

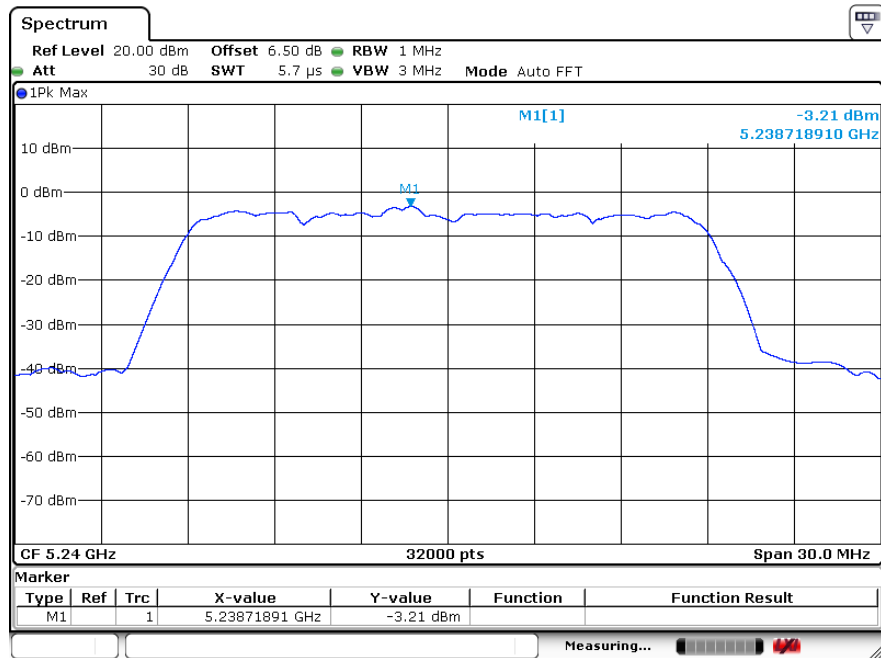

802.11n40 Channel: 38

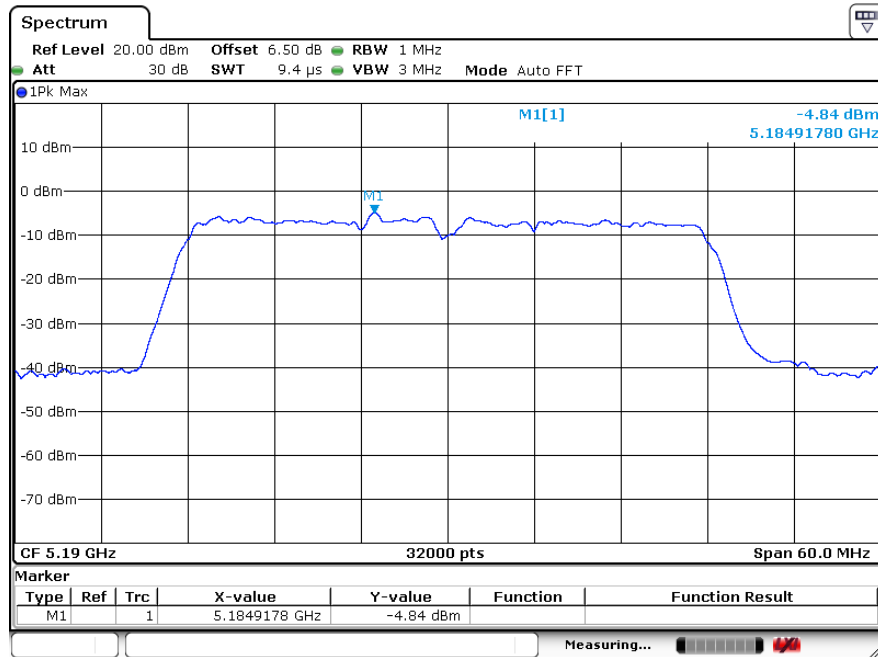

Channel: 46

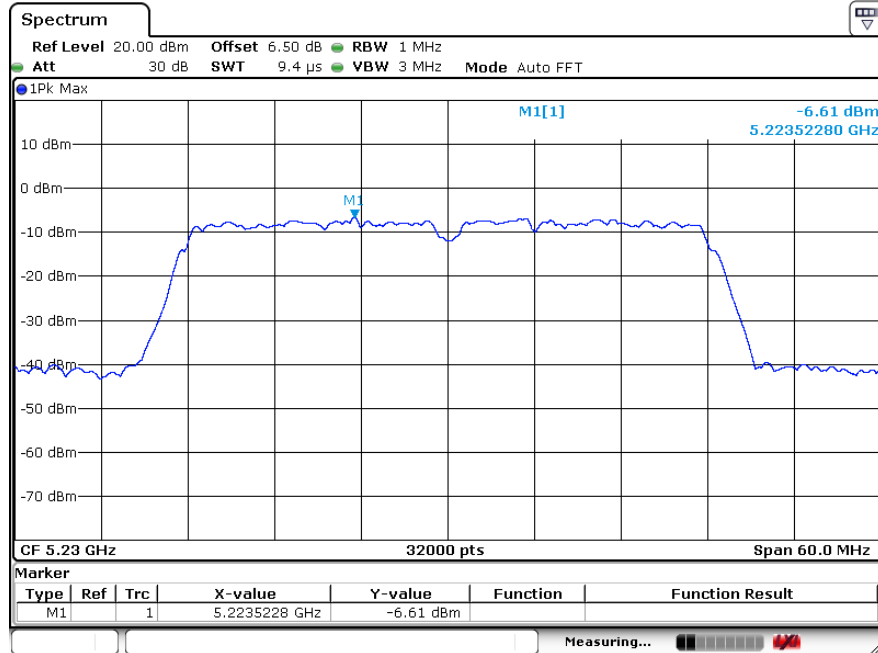

802.11ac40 Channel: 38

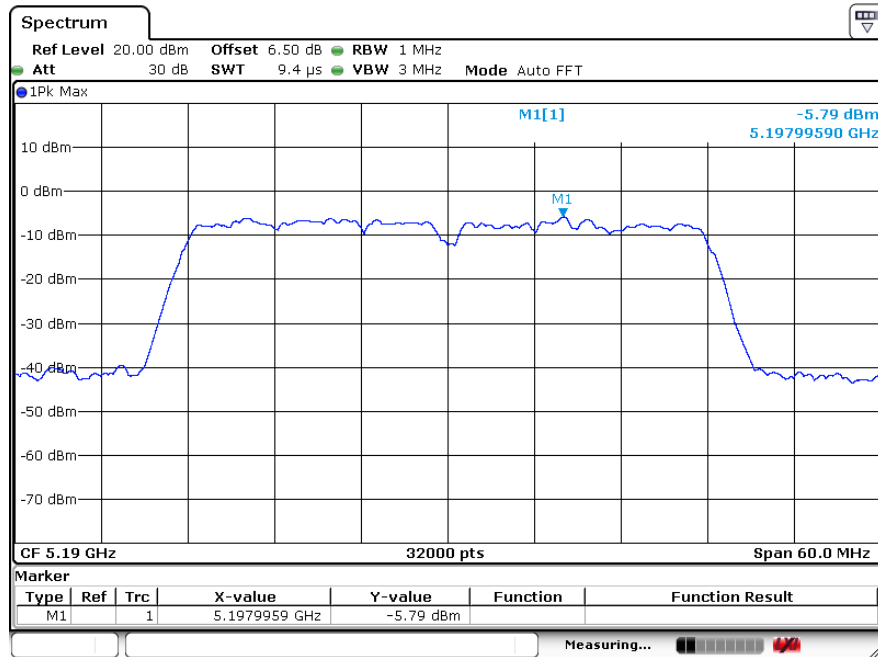

Channel: 46

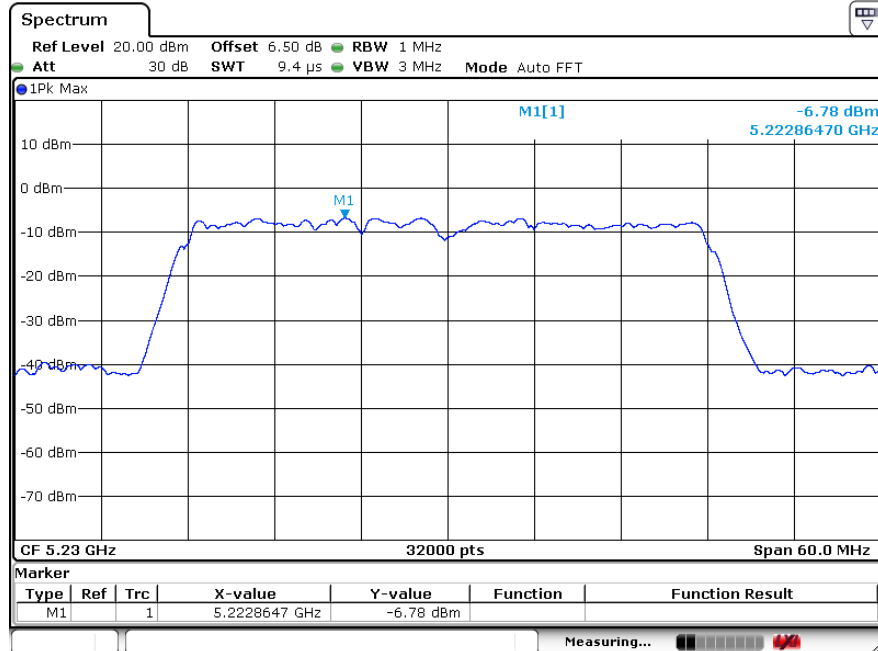

4. 26 dB & 99% Emission Bandwidth

4.1. TEST EQUIPMENT

Item	Equipment	Manufacturer	Model No.	Serial No.	Cal Due.	Cal. Interval
1	Spectrum analyzer	KEYSIGHT	N9010A	MY55150427	2019/05/25	1 Year
2	Attenuator	Mini-Circuits	BW-S10W2	101109	2018/12/17	1 Year
3	RF Cable	Micable	C10-01-01-1	100309	2018/12/17	1 Year
4	Spectrum analyzer	R&S	FSV40	101470	2019/06/28	1 Year

4.2. BLOCK DIAGRAM OF TEST SETUP

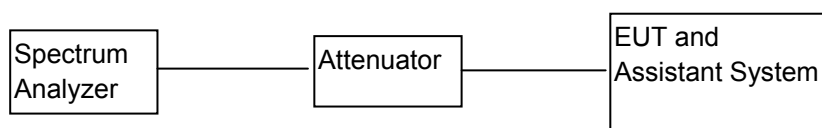

4.3. APPLIED PROCEDURES / LIMIT

The maximum power spectral density is measured as a conducted emission by direct connection of a calibrated test instrument to the equipment under test. If the device cannot be connected directly, alternative techniques acceptable to the Commission may be used. Measurements in the 5.725-5.85 GHz band are made over a reference bandwidth of 500 kHz or the 26 dB emission bandwidth of the device, whichever is less. Measurements in the 5.15-5.25 GHz, 5.25-5.35 GHz, and the 5.47-5.725 GHz bands are made over a bandwidth of 1 MHz or the 26 dB emission bandwidth of the device, whichever is less. A narrower resolution bandwidth can be used, provided that the measured power is integrated over the full reference bandwidth.

4.4. TEST PROCEDURE

- Set RBW = approximately 1% of the emission bandwidth.
- Set the VBW > RBW.
- Detector = Peak.
- Trace mode = max hold.
- Measure the maximum width of the emission that is 26 dB down from the maximum of the emission. Compare this with the RBW setting of the analyzer. Readjust RBW and repeat measurement as needed until the RBW/EBW ratio is approximately 1%.

The following procedure shall be used for measuring (99 %) power bandwidth:

- Set center frequency to the nominal EUT channel center frequency.
- Set span = 1.5 times to 5.0 times the OBW.
- Set RBW = 1 % to 5 % of the OBW
- Set VBW $\geq 3 \cdot$ RBW
- Video averaging is not permitted. Where practical, a sample detection and single sweep mode shall be used. Otherwise, peak detection and max hold mode (until the trace stabilizes)

shall be used.

6. Use the 99 % power bandwidth function of the instrument (if available).
7. If the instrument does not have a 99 % power bandwidth function, the trace data points are recovered and directly summed in power units. The recovered amplitude data points, beginning at the lowest frequency, are placed in a running sum until 0.5 % of the total is reached; that frequency is recorded as the lower frequency. The process is repeated until 99.5 % of the total is reached; that frequency is recorded as the upper frequency. The 99% occupied bandwidth is the difference between these two frequencies.

4.5. TEST RESULT

CH. No.	Frequency (MHz)	26dB Occupied Bandwidth (MHz)			99% Occupied Bandwidth (MHz)		
		802.11a	802.11n (HT20)	802.11ac (VHT20)	802.11a	802.11n (HT20)	802.11ac (VHT20)
36	5180.00	20.40	20.46	20.49	16.87	17.72	17.79
40	5200.00	20.17	20.33	20.38	16.61	17.78	17.73
48	5240.00	20.39	20.38	20.43	16.80	17.77	17.73

CH. No.	Frequency (MHz)	26dB Occupied Bandwidth (MHz)		99% Occupied Bandwidth (MHz)	
		802.11n(HT40)	802.11ac(VHT40)	802.11n(HT40)	802.11ac(VHT40)
38	5190.00	40.25	39.92	36.34	36.14
46	5230.00	39.94	40.06	36.29	36.26

26dB BW 802.11a Channel: 36

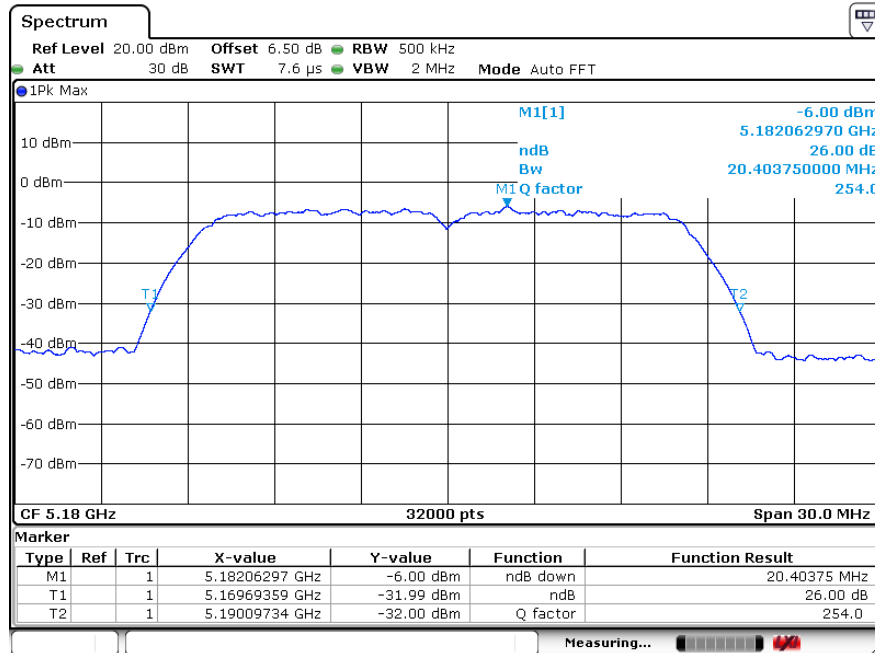

Channel: 40

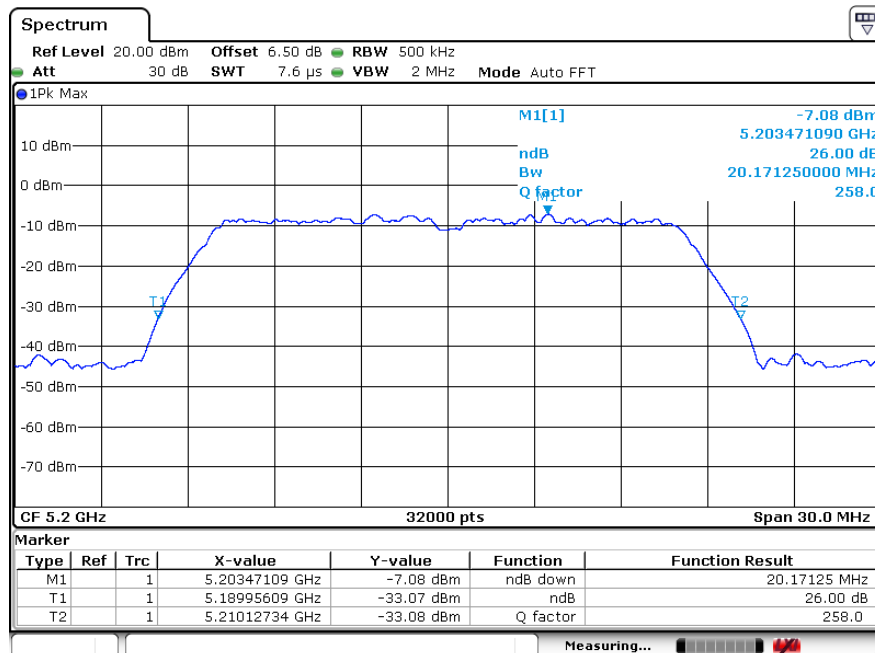

Channel: 48

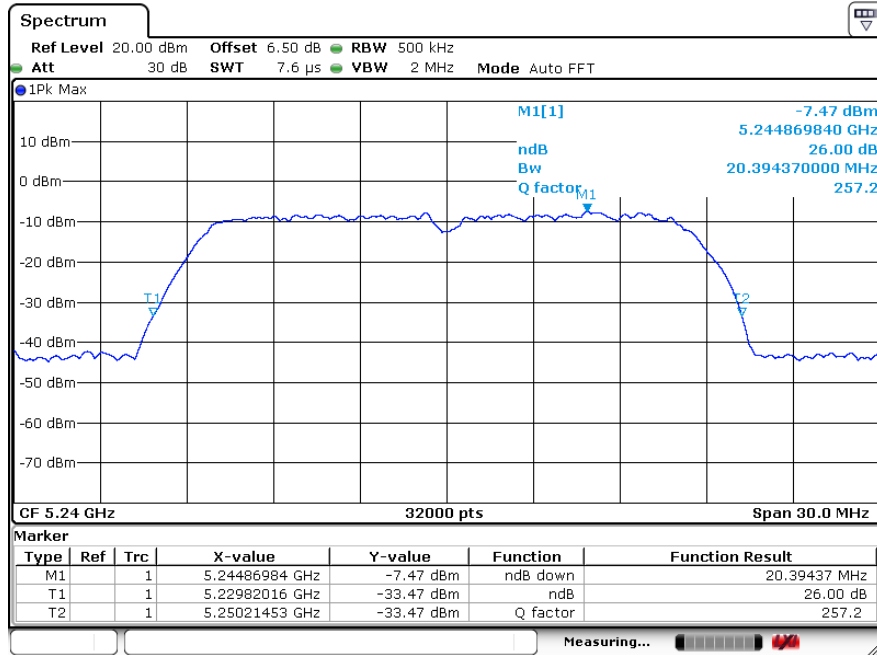

26dB BW 802.11n20 Channel: 36

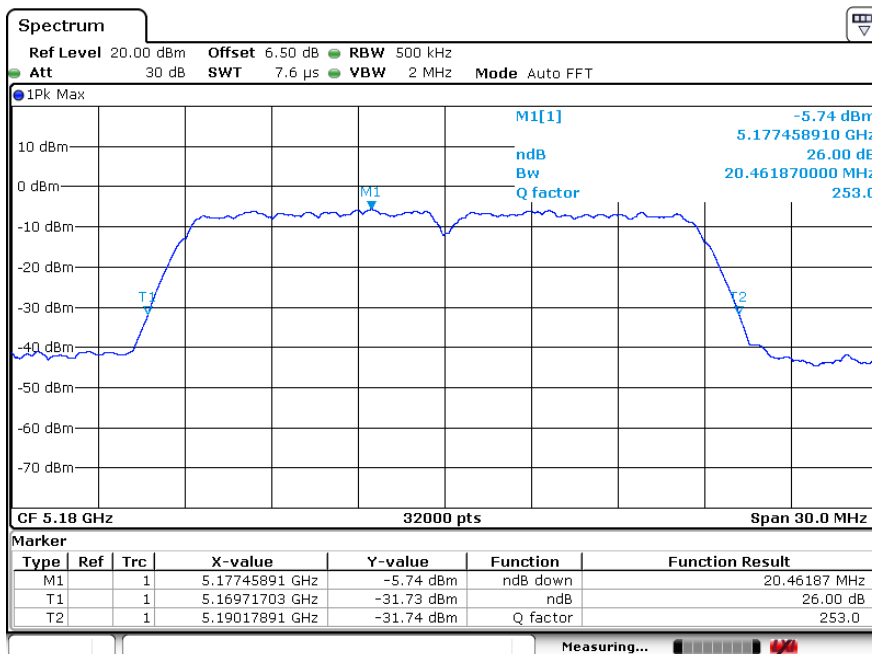

Channel: 40

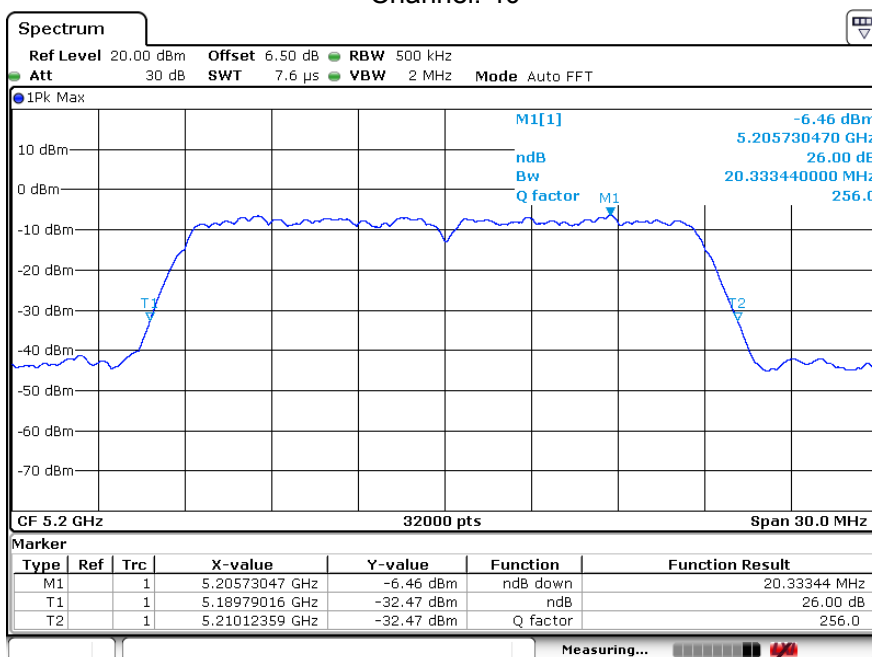

Channel: 48

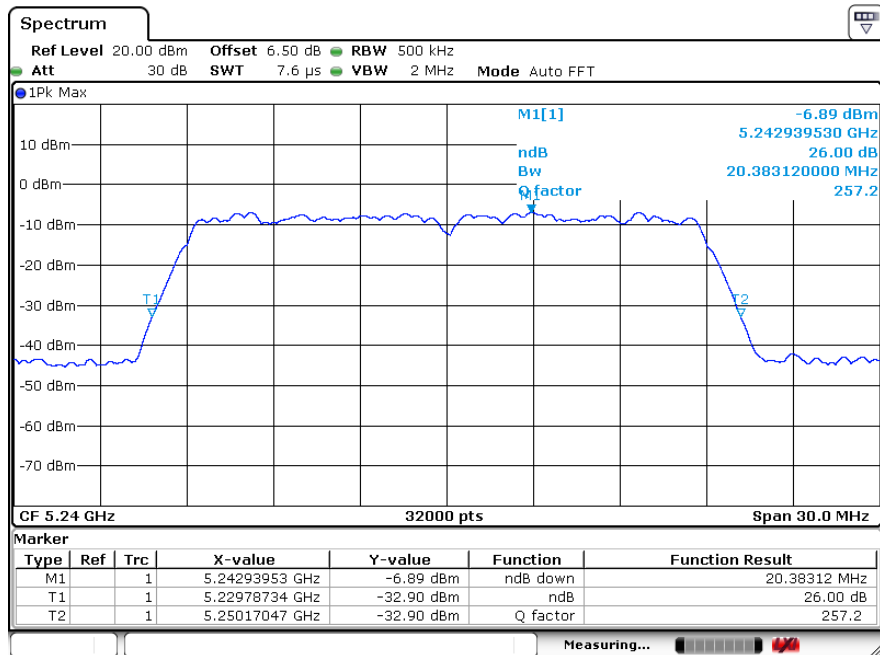

802.11ac20 Channel: 36

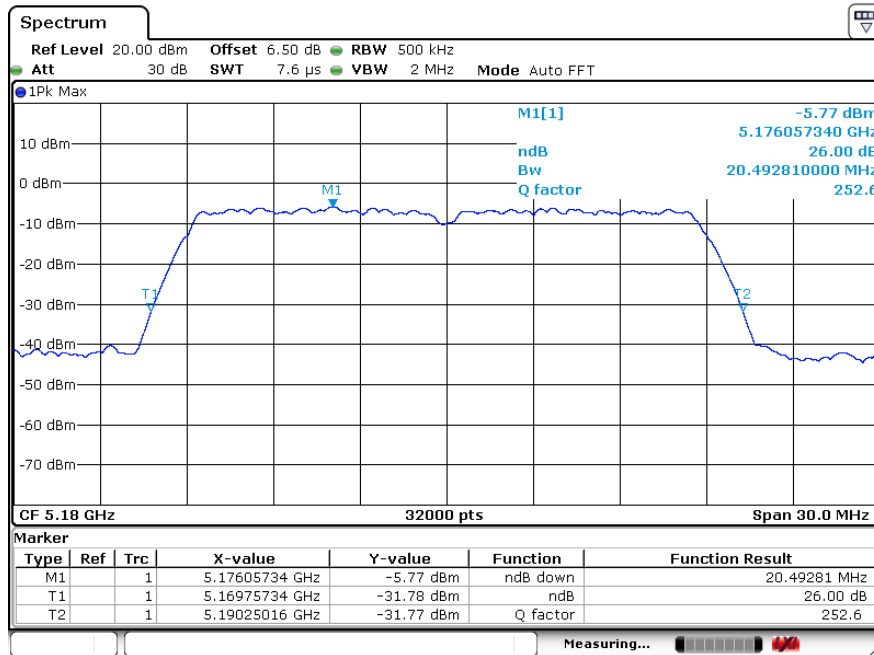

Channel: 40

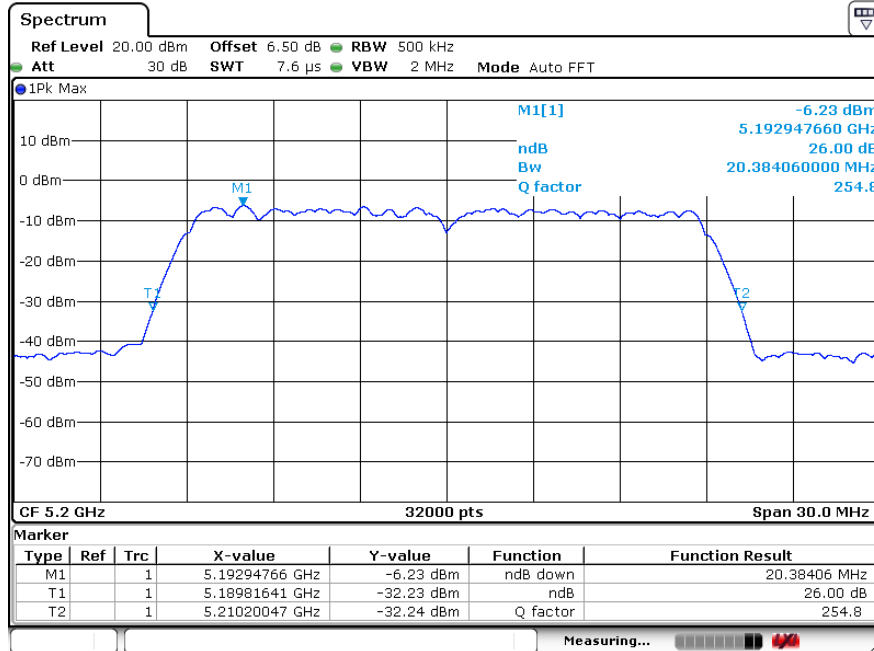

Channel: 48

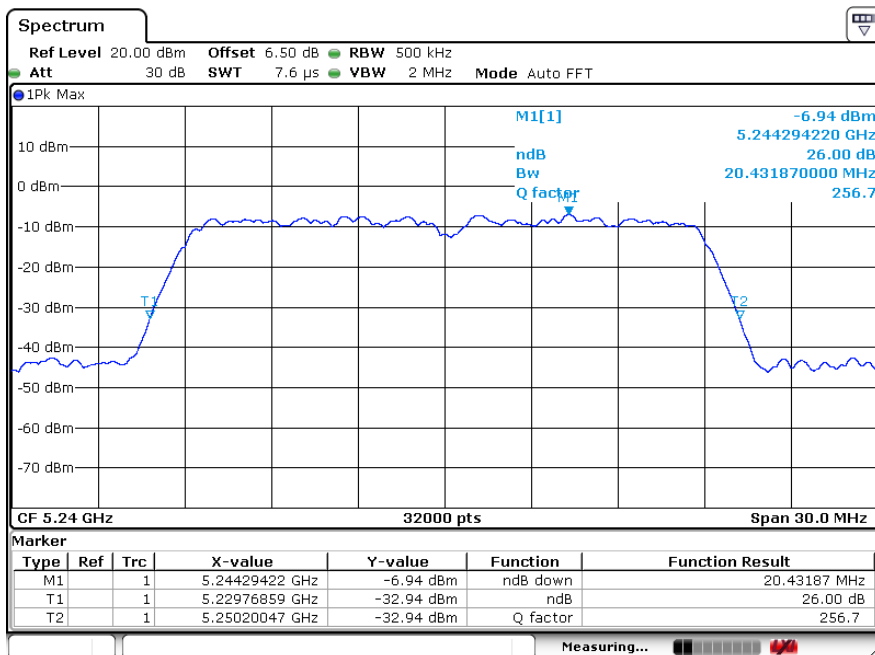

26dB BW 802.11n40 Channel: 38

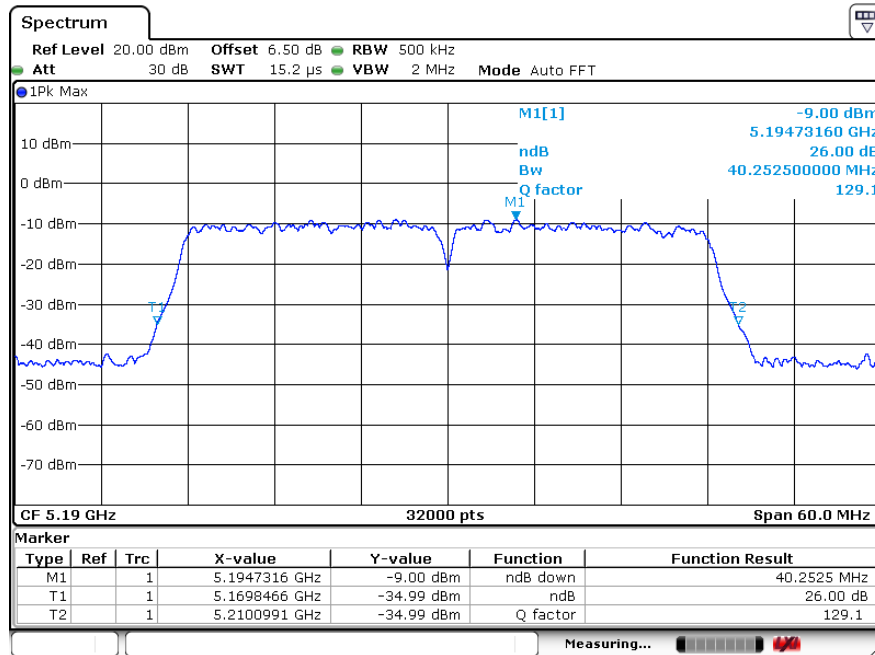

Channel: 46

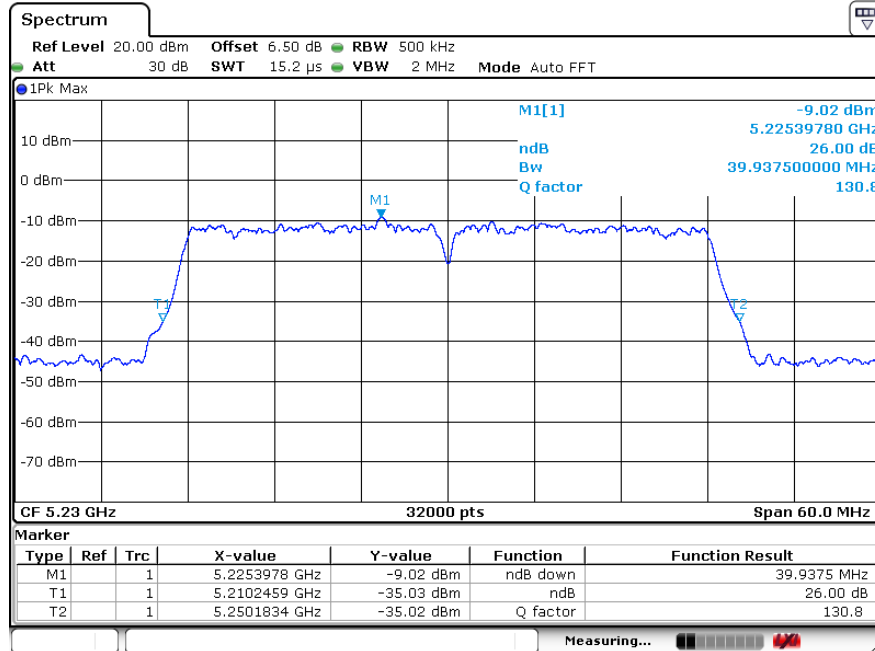

26dB BW 802.11ac40 Channel: 38

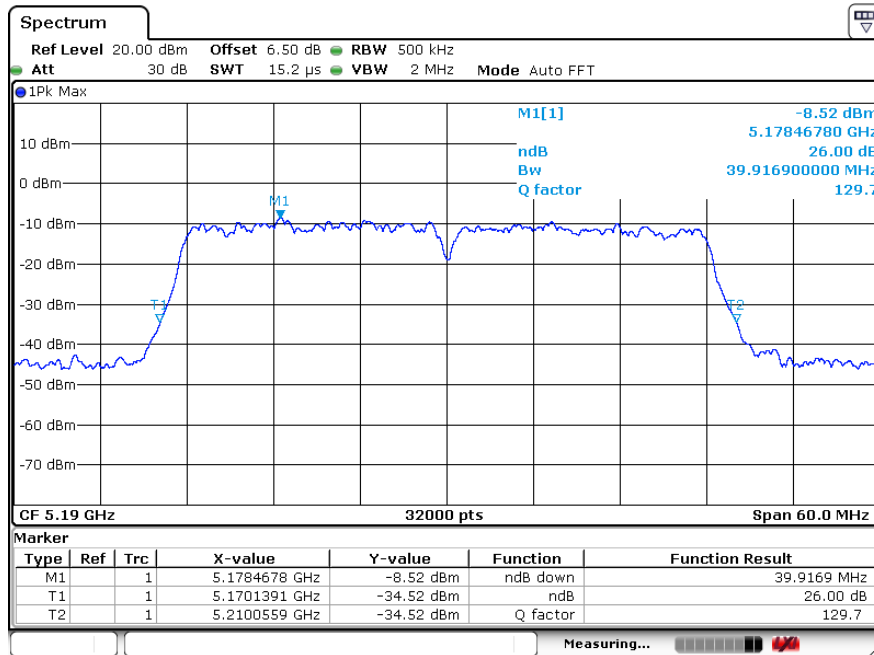

Channel: 46

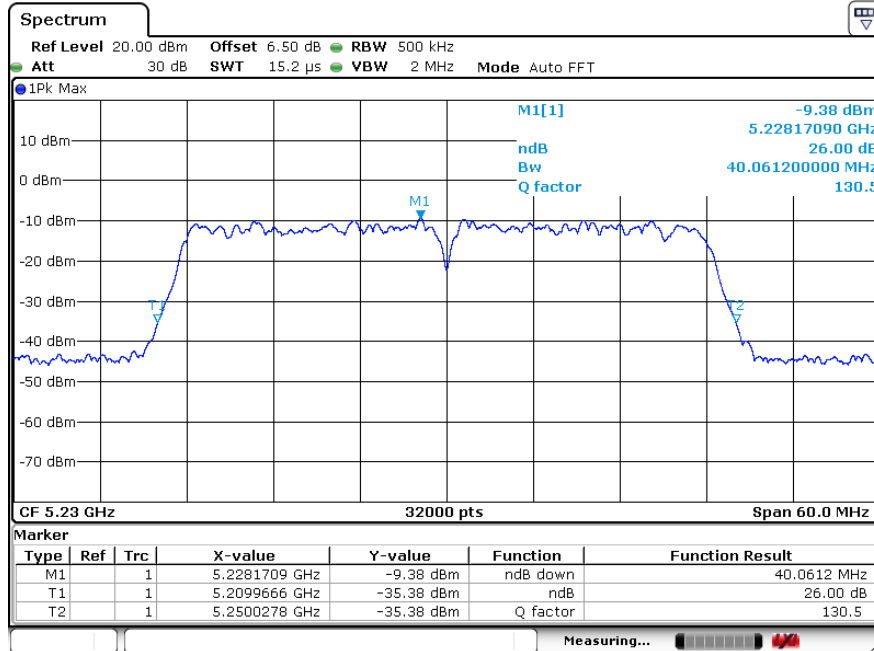

99% OBW 802.11a Channel: 36

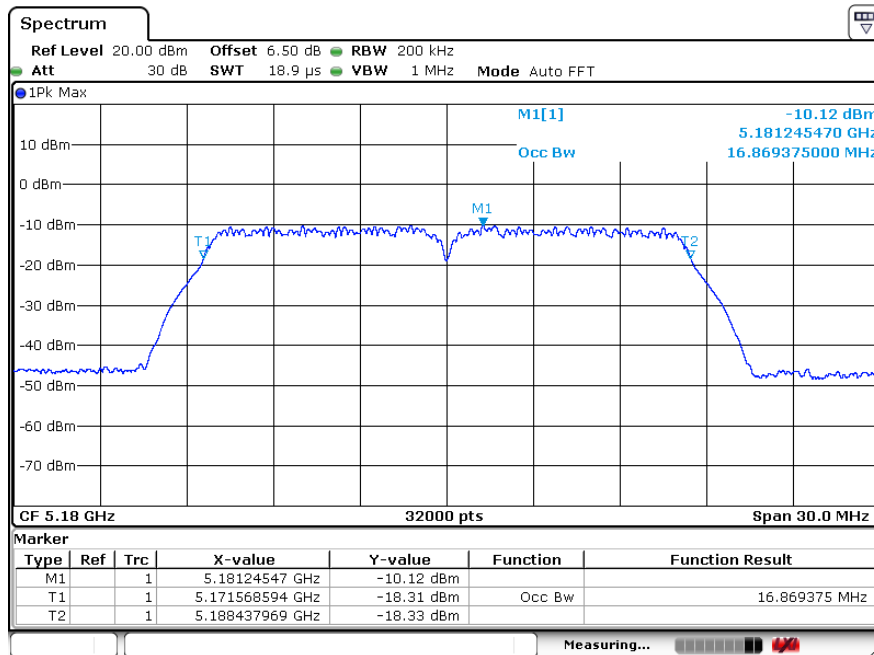

Channel: 40

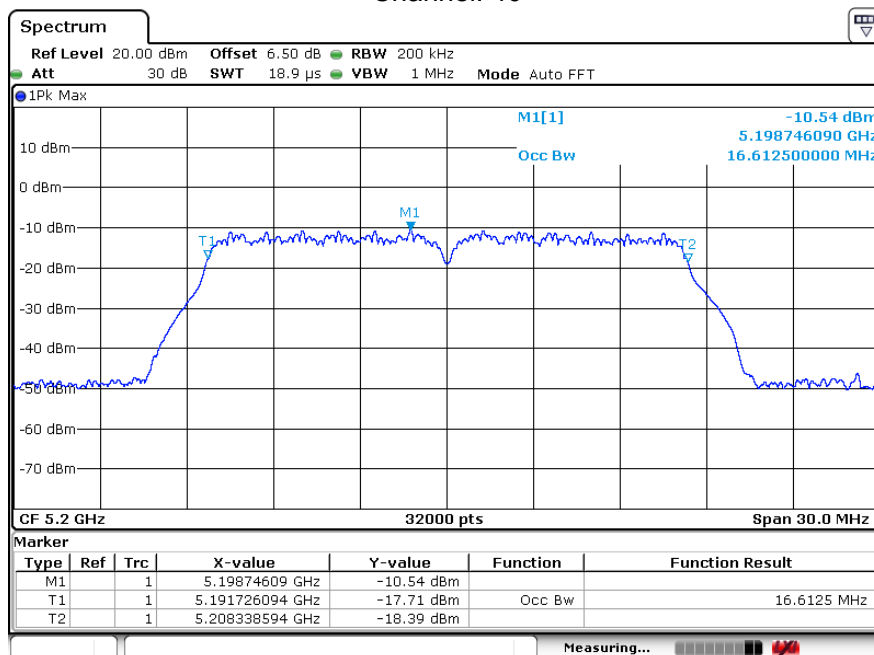

Channel: 48

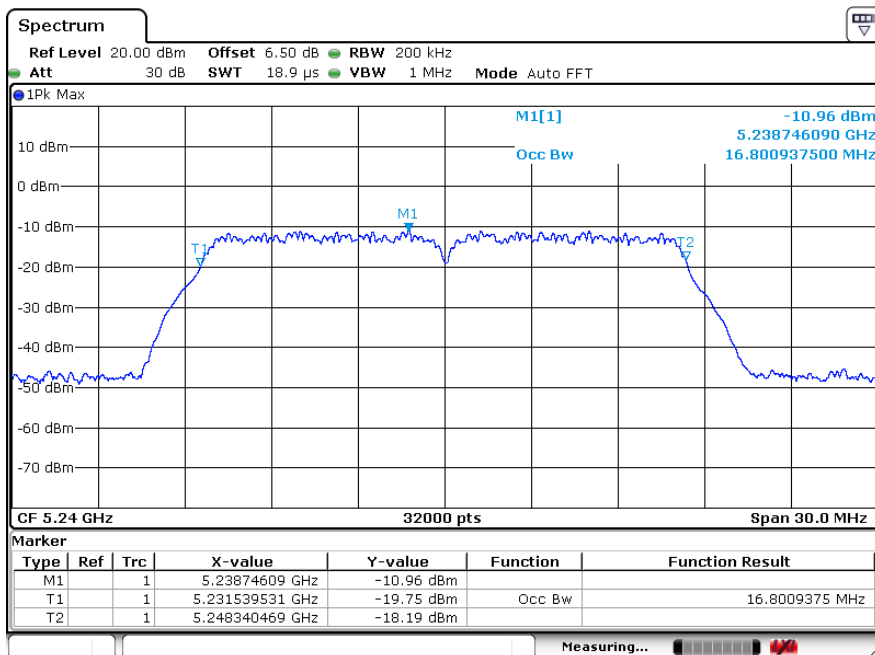

99% OBW 802.11n20 Channel: 36

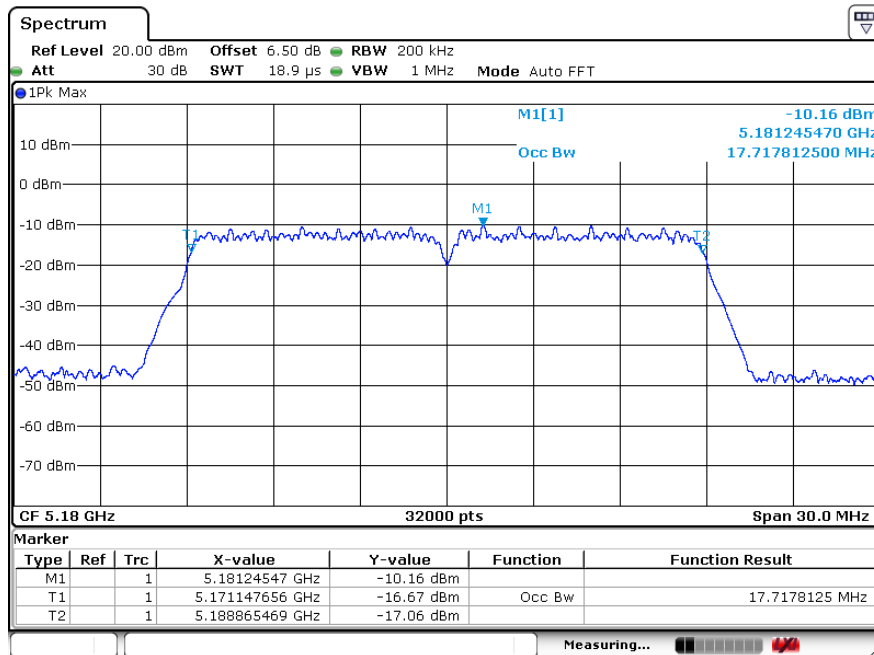

Channel: 40

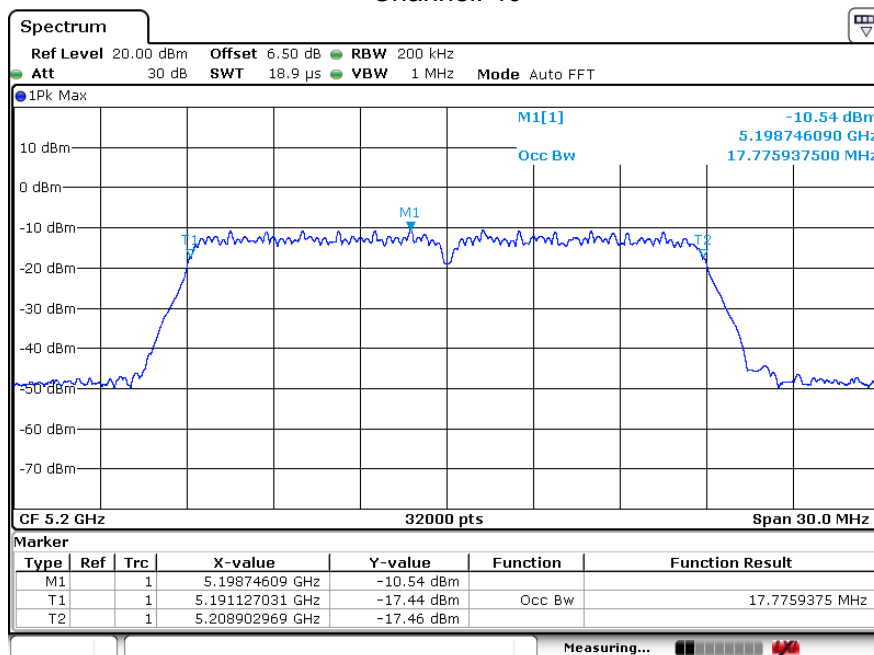

Channel: 48

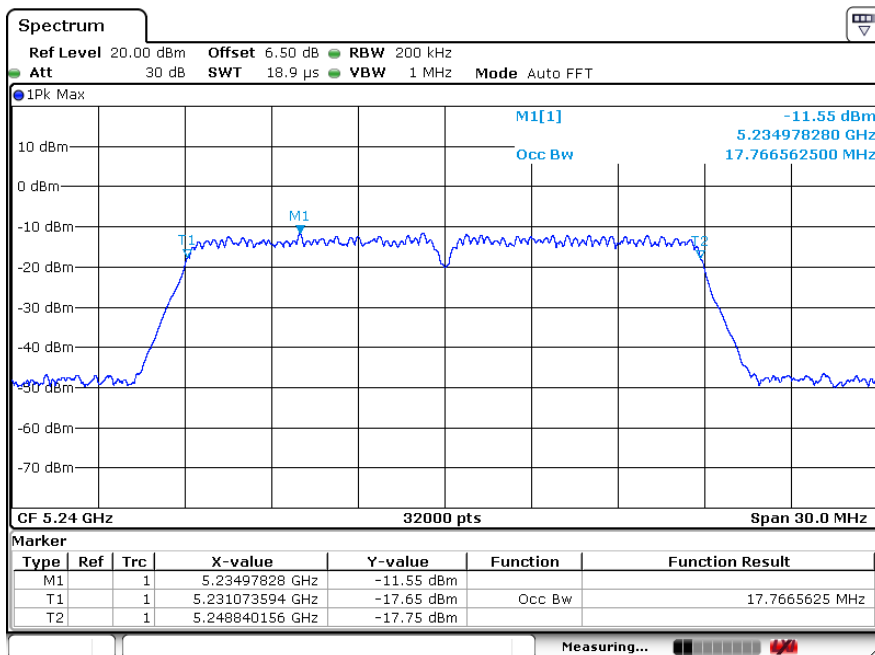

99% OBW 802.11ac20 Channel: 36

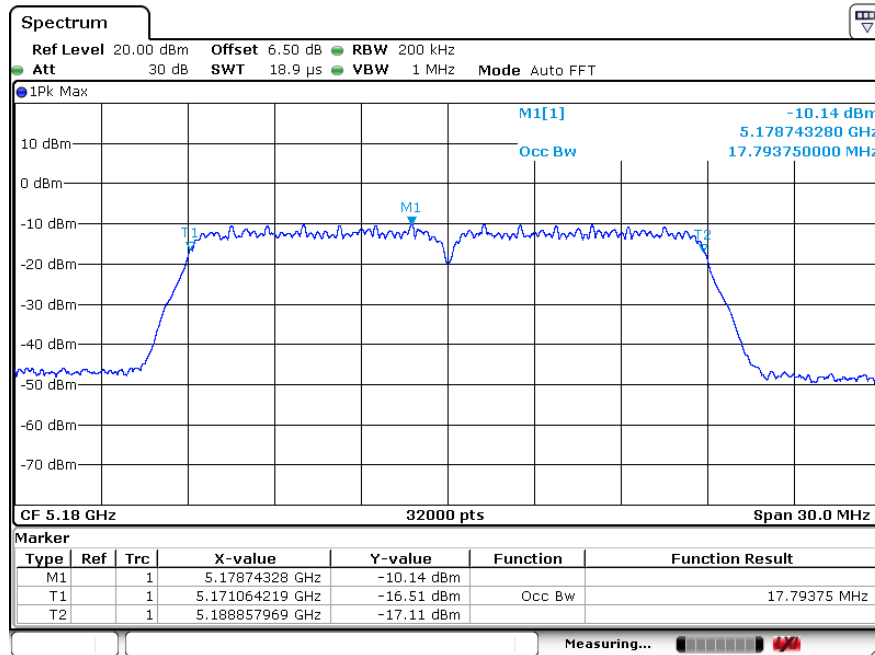

Channel: 40

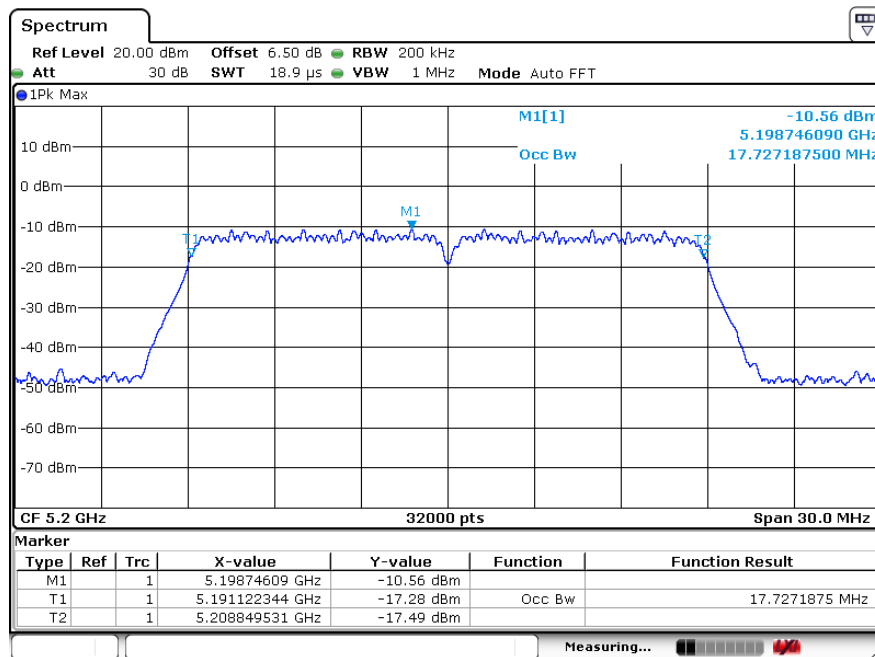

Channel: 48

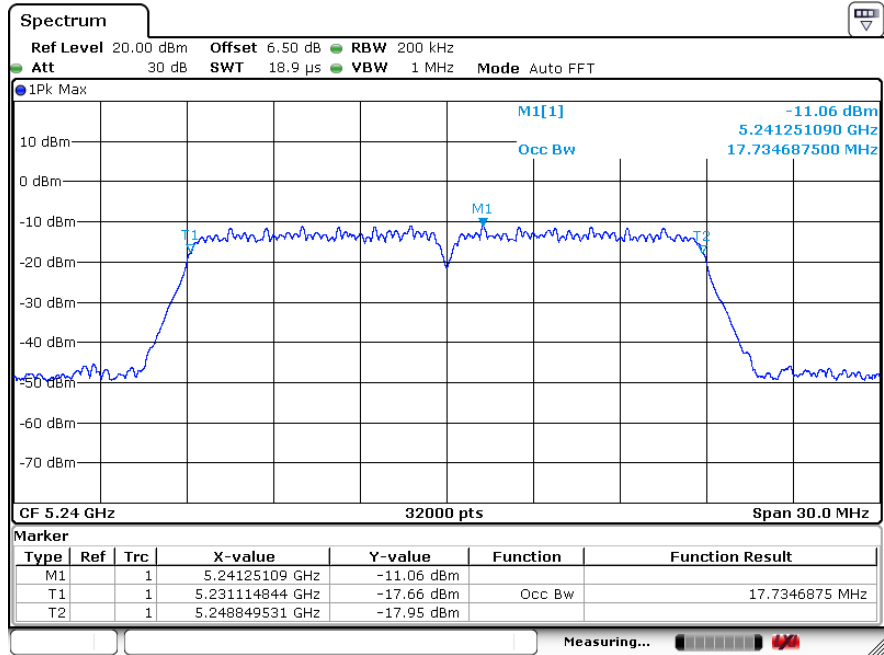

99% OBW 802.11n40 Channel: 38

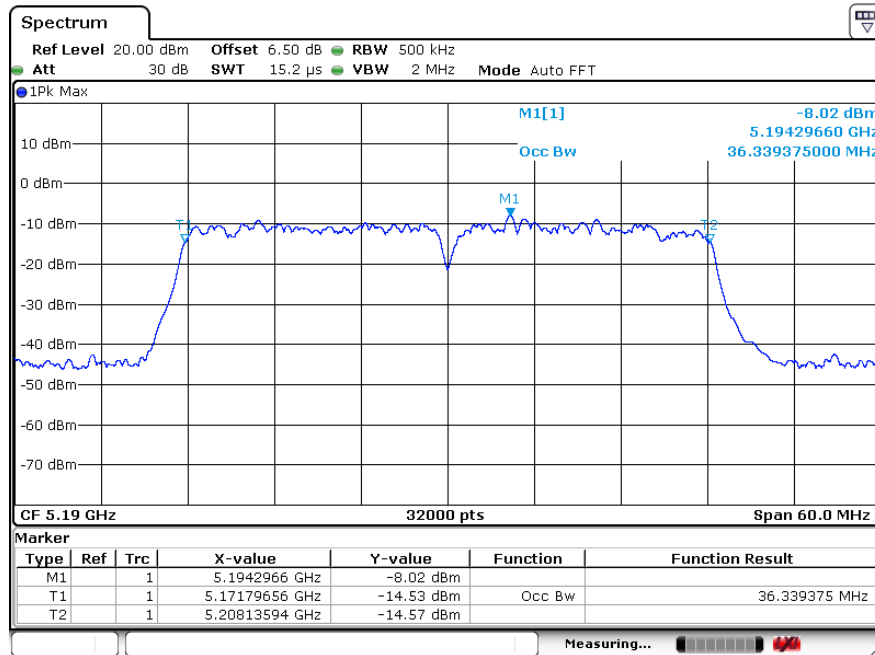

Channel: 46

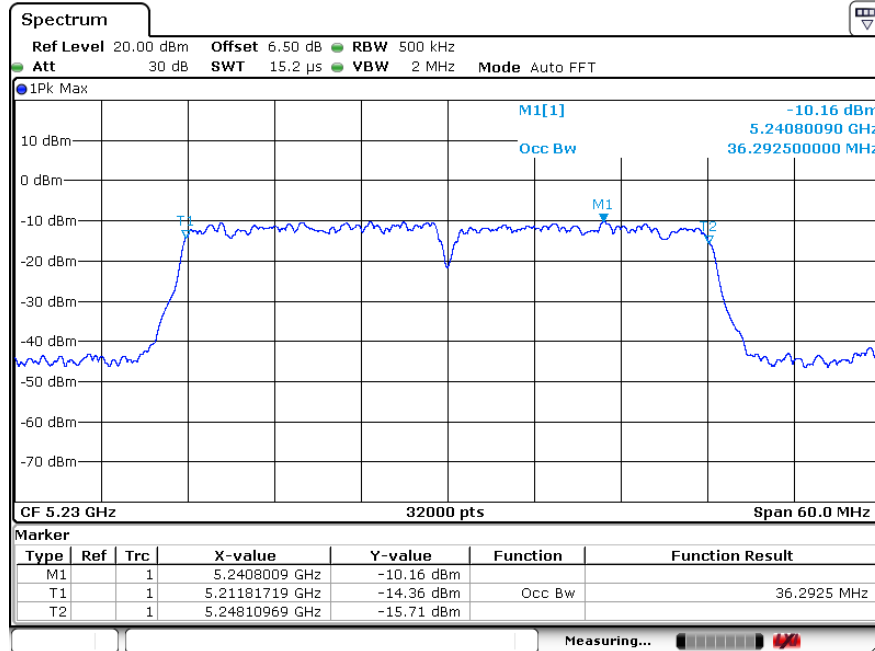

99% OBW 802.11ac40 Channel: 38

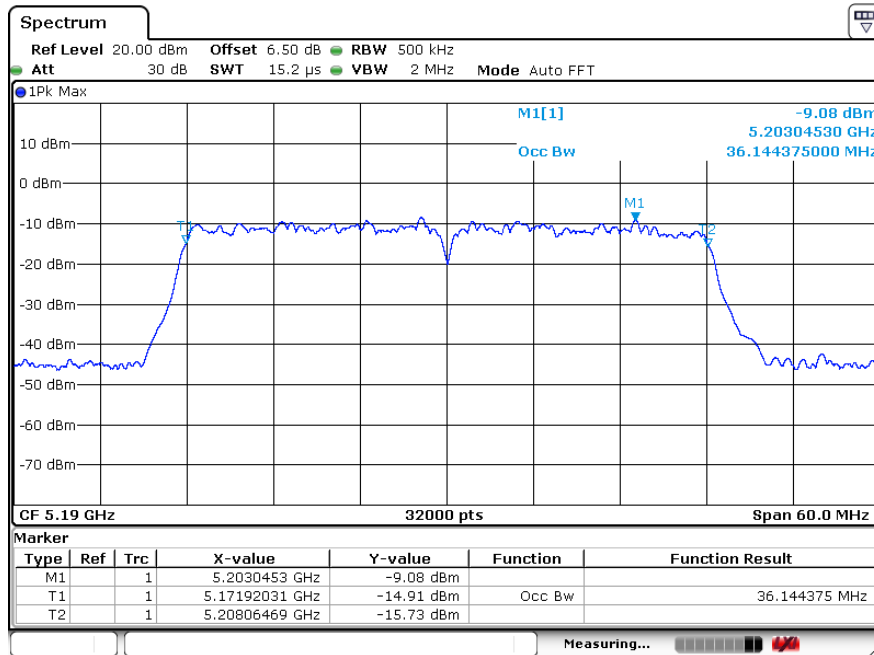

Channel: 46

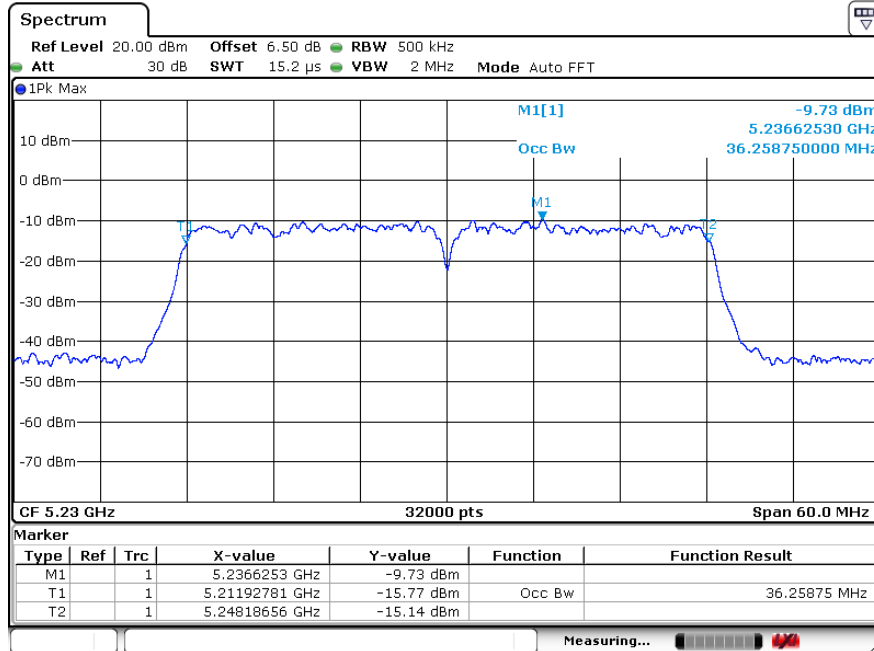

5. MAXIMUM CONDUCTED OUTPUT POWER

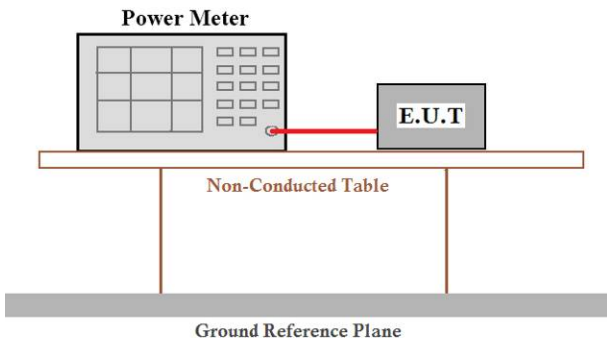
Test Requirement:	FCC Part15 E Section 15.407
Test Method:	KDB 789033 D02 General UNII Test Procedures New Rules v02r01
Limit:	For the band 5.15-5.25 GHz, the maximum conducted output power over the frequency bands of operation shall not exceed 250mW. For the band 5.745-5.850 GHz, the maximum conducted output power over the frequency bands of operation shall not exceed 30dBm
Test setup:	 <p>The diagram illustrates the test setup. A Power Meter is connected via a red cable to an E.U.T. (Equipment Under Test). Both are placed on a Non-Conducted Table. Below the table is a Ground Reference Plane.</p>
Test procedure:	<p style="text-align: center;">Measurement using an RF average power meter</p> <p>(i) Measurements may be performed using a wideband RF power meter with a thermocouple detector or equivalent if all of the conditions listed below are satisfied</p> <p>a) The EUT is configured to transmit continuously or to transmit with a constant duty cycle.</p> <p>b) At all times when the EUT is transmitting, it must be transmitting at its maximum power control level.</p> <p>c) The integration period of the power meter exceeds the repetition period of the transmitted signal by at least a factor of five.</p> <p>(ii) If the transmitter does not transmit continuously, measure the duty cycle, x, of the transmitter output signal as described in section B).</p> <p>(iii) Measure the average power of the transmitter. This measurement is an average over both the on and off periods of the transmitter.</p> <p>(iv) Adjust the measurement in dBm by adding $10 \log(1/x)$ where x is the duty cycle (e.g., $10\log(1/0.25)$ if the duty cycle is 25 percent).</p>
Test Instruments:	Refer to section 5.10 for details
Test mode:	Refer to section 5.3 for details

5.1. TEST RESULT

CH. No.	Frequency (MHz)	Output Power (dBm)			Limit(dBm)	Result
		802.11a	802.11n (HT20)	802.11ac (VHT20)		
36	5180.00	5.26	5.50	5.21	24	Pass
40	5200.00	5.46	5.52	5.25	24	Pass
48	5240.00	5.03	5.49	5.17	24	Pass

CH. No.	Frequency (MHz)	Output Power (dBm)		Limit(dBm)	Result
		802.11n(HT40)	802.11ac(VHT40)		
38	5190.00	5.32	5.45	24	Pass
46	5230.00	5.34	5.32	24	Pass

6. Band Edges Measurement

Test Requirement:	FCC Part15 E Section 15.407 and 5.205																							
Test Method:	ANSI C63.10:2013																							
Test site:	Measurement Distance: 3m																							
Receiver setup:	<table border="1"> <thead> <tr> <th>Frequency</th> <th>Detector</th> <th>RBW</th> <th>VBW</th> <th>Remark</th> </tr> </thead> <tbody> <tr> <td>30MHz-1GHz</td> <td>Quasi-peak</td> <td>100KHz</td> <td>300KHz</td> <td>Quasi-peak Value</td> </tr> <tr> <td rowspan="2">Above 1GHz</td> <td>Peak</td> <td>1MHz</td> <td>3MHz</td> <td>Peak Value</td> </tr> <tr> <td>AV</td> <td>1MHz</td> <td>3MHz</td> <td>Average Value</td> </tr> </tbody> </table>				Frequency	Detector	RBW	VBW	Remark	30MHz-1GHz	Quasi-peak	100KHz	300KHz	Quasi-peak Value	Above 1GHz	Peak	1MHz	3MHz	Peak Value	AV	1MHz	3MHz	Average Value	
Frequency	Detector	RBW	VBW	Remark																				
30MHz-1GHz	Quasi-peak	100KHz	300KHz	Quasi-peak Value																				
Above 1GHz	Peak	1MHz	3MHz	Peak Value																				
	AV	1MHz	3MHz	Average Value																				
Limit:	<table border="1"> <thead> <tr> <th>Frequency</th> <th>Limit (dBuV/m @3m)</th> <th>Remark</th> </tr> </thead> <tbody> <tr> <td>30MHz-88MHz</td> <td>40.0</td> <td>Quasi-peak Value</td> </tr> <tr> <td>88MHz-216MHz</td> <td>43.5</td> <td>Quasi-peak Value</td> </tr> <tr> <td>216MHz-960MHz</td> <td>46.0</td> <td>Quasi-peak Value</td> </tr> <tr> <td>960MHz-1GHz</td> <td>54.0</td> <td>Quasi-peak Value</td> </tr> <tr> <td rowspan="2">Above 1GHz</td> <td>54.0</td> <td>Average Value</td> </tr> <tr> <td>74.0</td> <td>Peak Value</td> </tr> </tbody> </table> <p>Undesirable emission limits:</p> <ol style="list-style-type: none"> (1) For transmitters operating in the 5.15-5.25 GHz band: all emissions outside of the 5.15-5.35 GHz band shall not exceed an EIRP of -27 dBm/MHz. (2) For transmitters operating in the 5.25-5.35 GHz band: all emissions outside of the 5.15-5.35 GHz band shall not exceed an EIRP of -27 dBm/MHz. Devices operating in the 5.25-5.35 GHz band that generate emissions in the 5.15-5.25 GHz band must meet all applicable technical requirements for operation in the 5.15-5.25 GHz band (including indoor use) or alternatively meet an out-of-band emission EIRP limit of -27 dBm/MHz in the 5.15-5.25 GHz band. (3) For transmitters operating in the 5.47-5.725 GHz band: all emissions outside of the 5.47-5.725 GHz band shall not exceed an EIRP of -27 dBm/MHz. 				Frequency	Limit (dBuV/m @3m)	Remark	30MHz-88MHz	40.0	Quasi-peak Value	88MHz-216MHz	43.5	Quasi-peak Value	216MHz-960MHz	46.0	Quasi-peak Value	960MHz-1GHz	54.0	Quasi-peak Value	Above 1GHz	54.0	Average Value	74.0	Peak Value
Frequency	Limit (dBuV/m @3m)	Remark																						
30MHz-88MHz	40.0	Quasi-peak Value																						
88MHz-216MHz	43.5	Quasi-peak Value																						
216MHz-960MHz	46.0	Quasi-peak Value																						
960MHz-1GHz	54.0	Quasi-peak Value																						
Above 1GHz	54.0	Average Value																						
	74.0	Peak Value																						
Test Procedure:	<ol style="list-style-type: none"> a. The EUT was placed on the top of a rotating table 1.5 m above the ground at a 3 meter camber. The table was rotated 360 degrees to determine the position of the highest radiation. b. The EUT was set 3 meters away from the interference-receiving antenna, which was mounted on the top of a variable-height antenna tower. c. The antenna height is varied from one meter to four meters above the ground to determine the maximum value of the field strength. Both horizontal and vertical polarizations of the antenna are set to make the measurement. d. For each suspected emission, the EUT was arranged to its worst case and then the antenna was tuned to heights from 1 meter to 4 meters and the rotatable table was turned from 0 degrees to 360 degrees to find the maximum reading. e. The test-receiver system was set to Peak Detect Function and Specified Bandwidth with Maximum Hold Mode. f. If the emission level of the EUT in peak mode was 10dB lower than the limit specified, then testing could be stopped and the peak values of the EUT would be reported. Otherwise the emissions that did not have 10dB margin would be re-tested one by one using peak, quasi-peak or average method as specified and then reported in a 																							

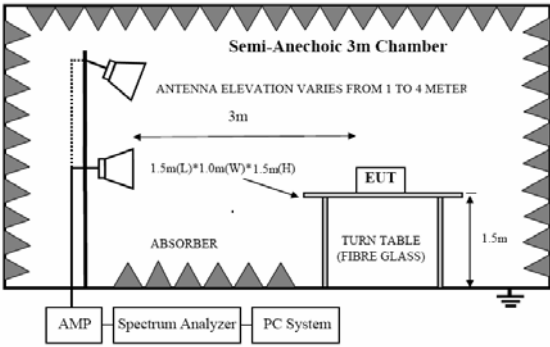
<p>Test setup:</p>	<p>data sheet.</p> <p style="text-align: center;">Above 1GHz</p> 
<p>Test Instruments:</p>	<p>Refer to section 5.10 for details</p>
<p>Test mode:</p>	<p>Refer to section 5.3 for details</p>
<p>Test results:</p>	<p>Pass</p>

Remark:

According to KDB 789033 D02V02r01 section G) 1) (d), for For measurements above 1000 MHz @ 3m distance, the limit of field strength is computed as follows:

$$E[\text{dBuV/m}] = \text{EIRP}[\text{dBm}] + 95.2;$$

For example, if EIRP = -27dBm

$$E[\text{dBuV/m}] = -27 + 95.2 = 68.2\text{dBuV/m}.$$

6.1. TEST RESULT

Peak value:

Test mode:		802.11a		Test channel:		Lowest	
Frequency (MHz)	Reading Level (dBuV)	Factor (dB/m)	Measure Level (dBuV/m)	Limit (dBuV/m)	Over limit(dB)	Detector	Antenna Pol.
5150	44.34	7.18	51.52	68.2	-16.68	PK	H
5150	43.25	7.18	50.43	68.2	-17.77	PK	V
Test mode:		802.11a		Test channel:		Highest	
Frequency (MHz)	Reading Level (dBuV)	Factor (dB/m)	Measure Level (dBuV/m)	Limit (dBuV/m)	Over limit(dB)	Detector	Antenna Pol.
5350	43.58	7.2	50.78	68.2	-17.42	PK	H
5350	49.24	7.2	56.44	68.2	-11.76	PK	V

Average:

Test mode:		802.11a		Test channel:		Lowest	
Frequency (MHz)	Reading Level (dBuV)	Factor (dB/m)	Measure Level (dBuV/m)	Limit (dBuV/m)	Over limit(dB)	Detector	Antenna Pol.
5150	31.25	7.18	38.43	48.2	-9.77	AV	H
5150	30.54	7.18	37.72	48.2	-10.48	AV	V
Test mode:		802.11a		Test channel:		Highest	
Frequency (MHz)	Reading Level (dBuV)	Factor (dB/m)	Measure Level (dBuV/m)	Limit (dBuV/m)	Over limit(dB)	Detector	Antenna Pol.
5350	30.24	7.2	37.44	48.2	-10.76	AV	H
5350	36.41	7.2	43.61	48.2	-4.59	AV	V

Peak value:

Test mode:		802.11n(HT20)		Test channel:		Lowest	
Frequency (MHz)	Reading Level (dBuV)	Factor (dB/m)	Measure Level (dBuV/m)	Limit (dBuV/m)	Over limit(dB)	Detector	Antenna Pol.
5150	47.25	7.18	54.43	68.2	-13.77	PK	H
5150	53.94	7.18	61.12	68.2	-7.08	PK	V
Test mode:		802.11n(HT20)		Test channel:		Highest	
Frequency (MHz)	Reading Level (dBuV)	Factor (dB/m)	Measure Level (dBuV/m)	Limit (dBuV/m)	Over limit(dB)	Detector	Antenna Pol.
5350	43.06	7.2	50.26	68.2	-17.94	PK	H
5350	50.87	7.2	58.07	68.2	-10.13	PK	V

Average:

Test mode:		802.11n(HT20)		Test channel:		Lowest	
Frequency (MHz)	Reading Level (dBuV)	Factor (dB/m)	Measure Level (dBuV/m)	Limit (dBuV/m)	Over limit(dB)	Detector	Antenna Pol.
5150	33.24	7.18	40.42	48.2	-7.78	AV	H
5150	38.14	7.18	45.32	48.2	-2.88	AV	V
Test mode:		802.11n(HT20)		Test channel:		Highest	
Frequency (MHz)	Reading Level (dBuV)	Factor (dB/m)	Measure Level (dBuV/m)	Limit (dBuV/m)	Over limit(dB)	Detector	Antenna Pol.
5350	30.23	7.2	37.43	48.2	-10.77	AV	H
5350	36.17	7.2	43.37	48.2	-4.83	AV	V

Peak value:

Test mode:		802.11n(HT40)		Test channel:		Lowest	
Frequency (MHz)	Reading Level	Factor	Measure Level	Limit (dBuV/m)	Margin (dB)	Detector	Antenna Pol.
5150	42.98	7.18	50.16	68.2	-18.04	PK	H
5150	43.32	7.18	50.5	68.2	-17.7	PK	V
Test mode:		802.11n(HT40)		Test channel:		Highest	
Frequency (MHz)	Reading Level	Factor	Measure Level	Limit (dBuV/m)	Margin (dB)	Detector	Antenna Pol.
5350	43.97	7.2	51.17	68.2	-17.03	PK	H
5350	47.25	7.2	54.45	68.2	-13.75	PK	V

Average:

Test mode:		802.11n(HT40)		Test channel:		Lowest	
Frequency (MHz)	Reading Level	Factor	Measure Level	Limit (dBuV/m)	Margin (dB)	Detector	Antenna Pol.
5150	30.14	7.18	37.32	48.2	-10.88	AV	H
5150	30.05	7.18	37.23	48.2	-10.97	AV	V
Test mode:		802.11n(HT40)		Test channel:		Highest	
Frequency (MHz)	Reading Level	Factor	Measure Level	Limit (dBuV/m)	Margin (dB)	Detector	Antenna Pol.
5350	30.46	7.2	37.66	48.2	-10.54	AV	H
5350	32.35	7.2	39.55	48.2	-8.65	AV	V

Peak value:

Test mode:		802.11ac(VHT80)		Test channel:		Lowest	
Frequency (MHz)	Reading Level	Factor	Measure Level	Limit (dBuV/m)	Margin (dB)	Detector	Antenna Pol.
5150	45.31	7.18	52.49	68.2	-15.71	PK	H
5150	48.25	7.18	55.43	68.2	-12.77	PK	V
Test mode:		802.11ac(VHT80)		Test channel:		Highest	
Frequency (MHz)	Reading Level	Factor	Measure Level	Limit (dBuV/m)	Margin (dB)	Detector	Antenna Pol.
5350	46.11	7.2	53.31	68.2	-14.89	PK	H
5350	47.94	7.2	55.14	68.2	-13.06	PK	V

Average:

Test mode:		802.11ac(VHT80)		Test channel:		Lowest	
Frequency (MHz)	Reading Level	Factor	Measure Level	Limit (dBuV/m)	Margin (dB)	Detector	Antenna Pol.
5150	31.25	7.18	38.43	48.2	-9.77	AV	H
5150	33.64	7.18	40.82	48.2	-7.38	AV	V
Test mode:		802.11ac(VHT80)		Test channel:		Highest	
Frequency (MHz)	Reading Level	Factor	Measure Level	Limit (dBuV/m)	Margin (dB)	Detector	Antenna Pol.
5350	34.06	7.2	41.26	48.2	-6.94	AV	H
5350	35.19	7.2	42.39	48.2	-5.81	AV	V

7. RADIATED EMISSION MEASUREMENT

7.1. Test equipment

Item	Equipment	Manufacturer	Model No.	Serial No.	Calibrated until	Calibrated Date
1	EMI Test Receiver	R&S	ESCI	101307	12/17/2018	12/18/2017
2	Spectrum analyzer	Agilent	E4407B	US40240708	07/04/2019	07/05/2018
3	Trilog Broadband Antenna	Schwarzbeck	VULB9168	VULB9168-192	03/04/2019	03/05/2018
4	Double Ridged Horn Antenna	SCHWARZBEC K	BBHA 9120D1065	100276	12/17/2018	12/18/2017
5	Double Ridged Horn Antenna	SCHWARZBEC K	BBHA 9120D1065	100546	12/17/2018	12/18/2017
6	Dipole antenna	Schwarzbeck	UHAP	1101	12/17/2018	12/18/2017
7	Dipole antenna	Schwarzbeck	VHAP	1118	12/17/2018	12/18/2017
8	Pre-Amplifier	CY	EMC011830	980136	12/17/2018	12/18/2017
9	Pre-amplifier	HP	8447F	3113A05680	12/17/2018	12/18/2017
10	RF Cable	R&S	R01	10403	12/17/2018	12/18/2017
11	RF Cable	R&S	R02	10512	12/17/2018	12/18/2017
12	RF Cable	R&S	R01	10454	12/17/2018	12/18/2017
13	RF Cable	R&S	R02	10343	12/17/2018	12/18/2017
14	Spectrum analyze	R&S	FSV40	101470	29/06/2019	06/29/2018
15	Measurement Software	Farad	EZ-EMC (Ver.ATT-03 A)	N/A	N/A	N/A

7.2. Block diagram of test setup

In 3m Anechoic Chamber Test Setup Diagram for 9KHz-30MHz

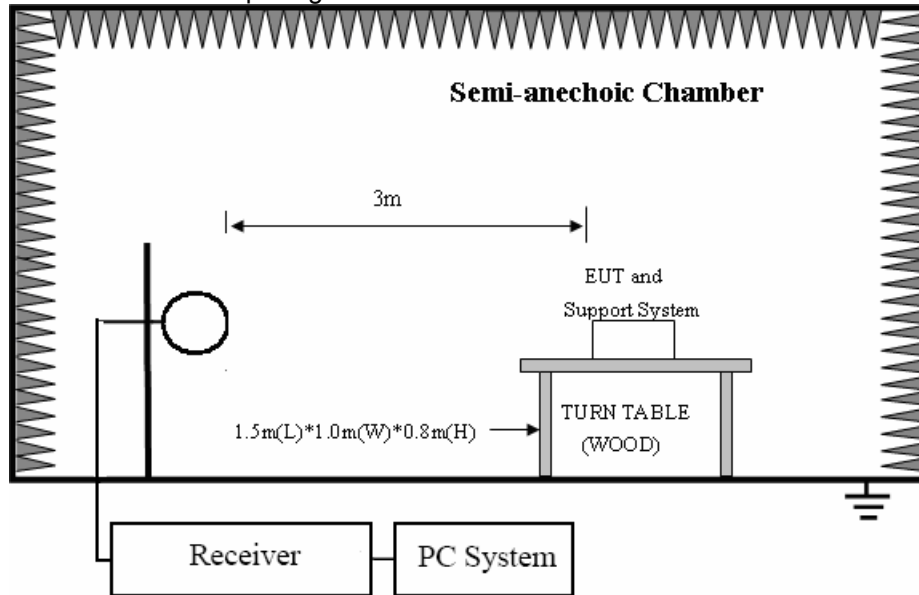

In 3m Anechoic Chamber Test Setup Diagram for 30MHz-1GHz

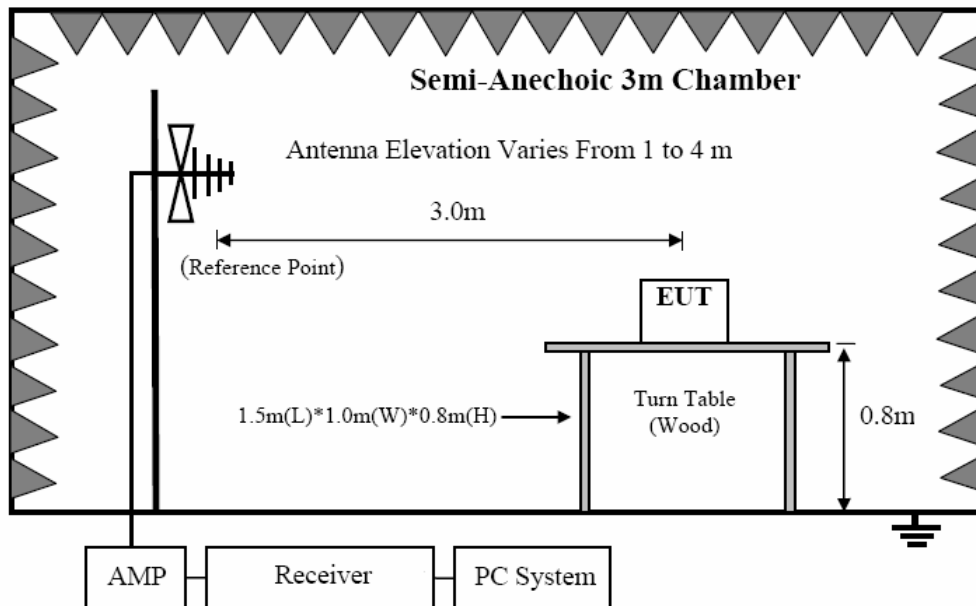

In 3m Anechoic Chamber Test Setup Diagram for frequency above 1GHz

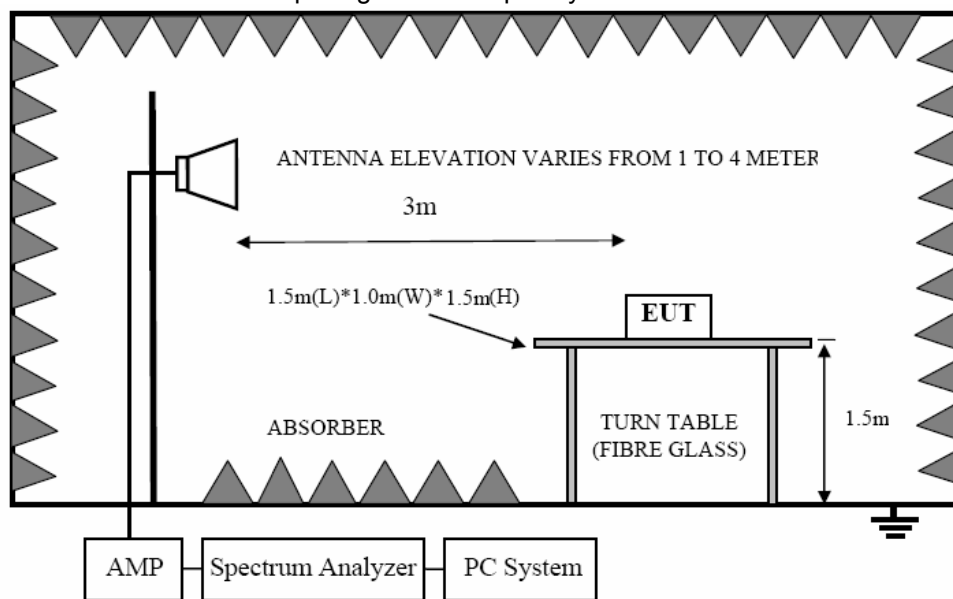

Note: For harmonic emissions test a appropriate high pass filter was inserted in the input port of AMP.

7.3. Limit

9.3.1 FCC 15.205 Restricted frequency band

MHz	MHz	MHz	GHz
0.090 - 0.110	16.42 - 16.423	399.9 - 410	4.5 - 5.15
¹ 0.495 - 0.505	16.69475 - 16.69525	608 - 614	5.35 - 5.46
2.1735 - 2.1905	16.80425 - 16.80475	960 - 1240	7.25 - 7.75
4.125 - 4.128	25.5 - 25.67	1300 - 1427	8.025 - 8.5
4.17725 - 4.17775	37.5 - 38.25	1435 - 1626.5	9.0 - 9.2
4.20725 - 4.20775	73 - 74.6	1645.5 - 1646.5	9.3 - 9.5
6.215 - 6.218	74.8 - 75.2	1660 - 1710	10.6 - 12.7
6.26775 - 6.26825	108 - 121.94	1718.8 - 1722.2	13.25 - 13.4
6.31175 - 6.31225	123 - 138	2200 - 2300	14.47 - 14.5
8.291 - 8.294	149.9 - 150.05	2310 - 2390	15.35 - 16.2
8.362 - 8.366	156.52475 - 156.52525	2483.5 - 2500	17.7 - 21.4
8.37625 - 8.38675	156.7 - 156.9	2690 - 2900	22.01 - 23.12
8.41425 - 8.41475	162.0125 - 167.17	3260 - 3267	23.6 - 24.0
12.29 - 12.293	167.72 - 173.2	3332 - 3339	31.2 - 31.8
12.51975 - 12.52025	240 - 285	3345.8 - 3358	36.43 - 36.5
12.57675 - 12.57725	322 - 335.4	3600 - 4400	(²)

9.3.2. FCC 15.209 Limit.

FREQUENCY MHz	DISTANCE Meters	FIELD STRENGTHS LIMIT	
		μV/m	dB(μV)/m
0.009 ~ 0.490	300	2400/F(KHz)	67.6-20log(F)
0.490 ~ 1.705	30	24000/F(KHz)	87.6-20log(F)
1.705 ~ 30.0	30	30	29.54
30 ~ 88	3	100	40.0
88 ~ 216	3	150	43.5
216 ~ 960	3	200	46.0
960 ~ 1000	3	500	54.0
Above 1000	3	74.0 dB(μV)/m (Peak) 54.0 dB(μV)/m (Average)	

Note: (1) The emission limits shown in the above table are based on measurements employing a CISPR QP detector except for the frequency bands 9-90KHz, 110-490KHz and above 1000MHz. Radiated emissions limits in these three bands are based on measurements employing an average detector.

(2) At frequencies below 30MHz, measurement may be performed at a distance closer than that specified, and the limit at closer measurement distance can be extrapolated by below formula:

$$\text{Limit}_{3m}(\text{dBuV/m}) = \text{Limit}_{30m}(\text{dBuV/m}) + 40\text{Log}(30m/3m)$$

9.3.3. Limit for this EUT

All the emissions appearing within 15.205 restricted frequency bands shall not exceed the limits shown in 15.209, all the other emissions shall be at least 30dB below the fundamental emissions, or comply with 15.209 limits.

7.4. Test Procedure

- (1) EUT was placed on a non-metallic table, 80 cm above the ground plane inside a semi-anechoic chamber.
- (2) Setup EUT and assistant system according clause 2.4 and 7.2
- (3) Test antenna was located 3m(except 18GHz-40GHz was 1m) from the EUT on an adjustable mast, and the antenna used as below table.

Test frequency range	Test antenna used
9KHz-30MHz	Active Loop antenna
30MHz-1GHz	Trilog Broadband Antenna
1GHz-18GHz	Double Ridged Horn Antenna(1GHz-18GHz)
18GHz-40GHz	Horn Antenna(18GHz-40GHz)

According ANSI C63.10:2013 clause 6.4.4.2 and 6.5.3, for measurements below 30 MHz, the loop antenna was positioned with its plane vertical from the EUT and rotated about its vertical axis for maximum response at each azimuth position around the EUT. And the loop antenna also be positioned with its plane horizontal at the specified distance from the EUT. The center of the loop is 1 m above the ground. for measurement above 30MHz, the Trilog Broadband Antenna or Horn Antenna was located 3m from EUT, Measurements were made with the antenna positioned in both the horizontal and vertical planes of Polarization, and the measurement antenna was varied from 1 m to 4 m. in height above the reference ground plane to obtain the maximum signal strength.

- (4) Below pre-scan procedure was first performed in order to find prominent frequency spectrum radiated emissions from 9KHz to 25GHz:
 - (a) Scanning the peak frequency spectrum with the antenna specified in step (3), and the EUT was rotated 360 degree, the antenna height was varied from 1m to 4m(Except loop antenna, it's fixed 1m above ground.)
 - (b) Change work frequency or channel of device if practicable.
 - (c) Change modulation type of device if practicable.
 - (d) new battery is used during testing
 - (e) Rotated EUT though three orthogonal axes to determine the attitude of EUT arrangement produces highest emissions.

Spectrum frequency from 9KHz to 25GHz (tenth harmonic of fundamental frequency) was investigated, and no any obvious emission were detected from 18GHz to 25GHz, so below final test was performed with frequency range from 9KHz to 18GHz.

- (5) For final emissions measurements at each frequency of interest, the EUT was rotated and the antenna height was varied between 1m and 4m in order to maximize the emission. Measurements in both horizontal and vertical polarities were made and the data was recorded. In order to find the maximum emission, the relative positions of equipments and all of the interface cables were changed according to ANSI C63.10 2013 on Radiated Emission test.
- (6) The emissions from 9KHz to 1GHz were measured based on CISPR QP detector except for the frequency bands 9-90KHz, 110-490KHz, for emissions from 9KHz-90KHz,110KHz-490KHz and above 1GHz were measured based on average detector, for emissions above 1GHz, peak emissions also be measured and need comply with Peak limit.
- (7) The emissions from 9KHz to 1GHz, QP or average values were measured with EMI receiver with below RBW

Frequency band	RBW
9KHz-150KHz	200Hz
150KHz-30MHz	9KHz
30MHz-1GHz	120KHz

- (8) For emissions above 1GHz, both Peak and Average level were measured with Spectrum Analyzer, and the RBW is set at 1MHz, VBW is set at 3MHz for Peak measure; RBW is set at 1MHz, VBW is set at 10Hz for Average measure(according ANSI C63.10:2013 clause 4.2.3.2.3 procedure for average measure). Peak detector is used for Peak and AV measurement both.

7.5. Test result(Below 30MHz)

EUT:	TrekStor Surftab theatre K13	Model No.:	TFMTKAW01216
Temperature:	24°C	Relative Humidity:	55%
Distance:	3m	Test Power:	120V 60Hz
Polarization:	--	Test Result:	Pass
Test Mode:	Keeping TX mode	Test By:	Smile

Freq. (MHz)	Reading (dBuV/m)	Limit (dBuV/m)	Margin (dB)	State P/F
--	--	--	--	P
--	--	--	--	P

Note:

The amplitude of spurious emissions which are attenuated by more than 20dB below the permissible value has no need to be reported.

Distance extrapolation factor = $20 \log(\text{specific distance}/\text{test distance})$ (dB);

Limit line = specific limits(dBuv) + distance extrapolation factor.

TEST RESULTS (Between 30M – 1000 MHz)

EUT:	TrekStor SurfTab theatre K13	Model No.:	TFMTKAW01216
Temperature:	24	Relative Humidity:	55%
Distance:	3m	Test Power:	AC120V/60Hz
Polarization:	Vertical	Test Result:	Pass
Standard:	(RE)FCC PART 15	Test By:	Smile
Test Mode:	Keeping TX mode		

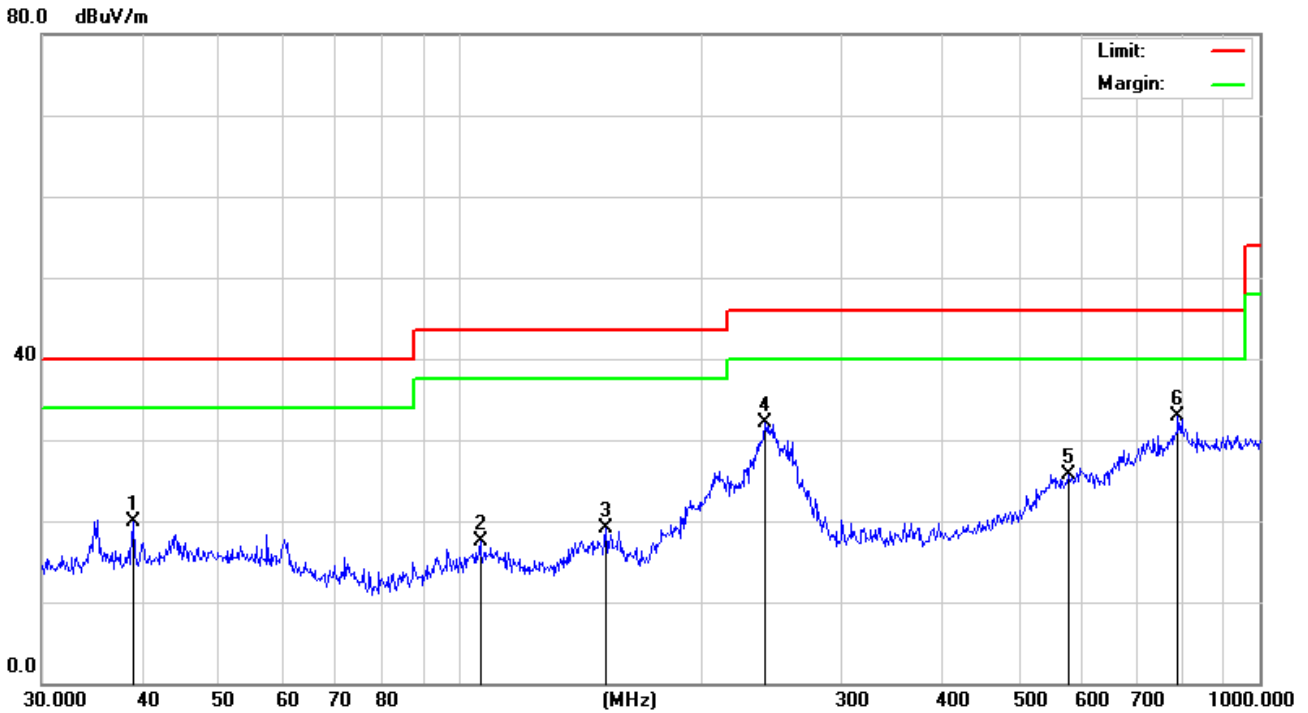

No.	Mk.	Freq. MHz	Reading Level dBuV	Correct Factor dB	Measure- ment dBuV/m	Limit dBuV/m	Over dB	Detector
1		39.0245	26.26	-6.32	19.94	40.00	-20.06	QP
2		106.0126	25.21	-7.79	17.42	43.50	-26.08	QP
3		152.1297	26.92	-7.82	19.10	43.50	-24.40	QP
4		240.8304	38.60	-6.51	32.09	46.00	-13.91	QP
5		576.6443	23.65	2.04	25.69	46.00	-20.31	QP
6	*	790.6188	25.25	7.69	32.94	46.00	-13.06	QP

The test result is calculated as the following:

- (1) Result = Reading + Correct Factor
- (2) Correct Factor = Antenna Factor + Cable Loss – Amplifier Gain + Attenuator
- (3) Margin = Result - Limit

EUT:	TrekStor SurfTab theatre K13	Model No.:	TFMTKAW01216
Temperature:	24	Relative Humidity:	55%
Distance:	3m	Test Power:	AC120V/60Hz
Polarization:	Horizontal	Test Result:	Pass
Standard:	(RE)FCC PART 15	Test By:	Smile
Test Mode:	Keeping TX mode		

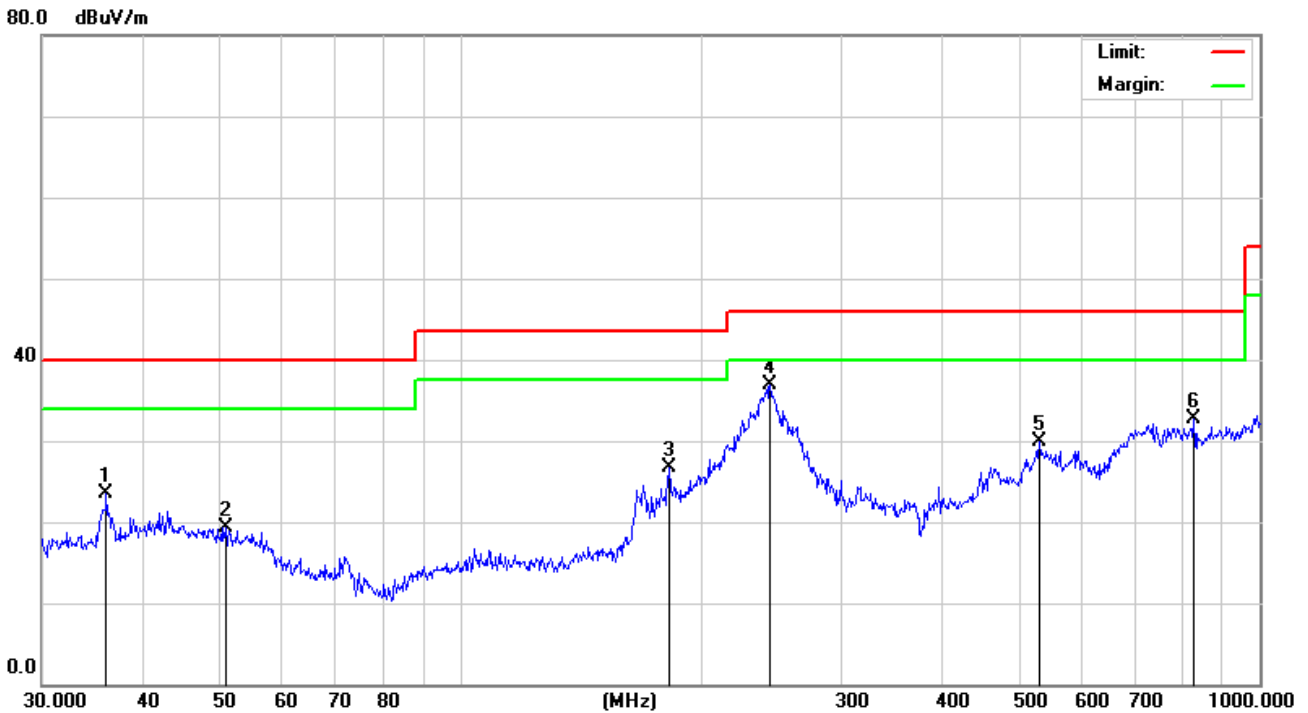

No.	Mk.	Freq. MHz	Reading Level dBuV	Correct Factor dB	Measure- ment dBuV/m	Limit dBuV/m	Over dB	Detector
1		36.1272	26.86	-3.41	23.45	40.00	-16.55	QP
2		50.9420	22.67	-3.45	19.22	40.00	-20.78	QP
3		182.5592	32.02	-5.33	26.69	43.50	-16.81	QP
4	*	244.2321	43.38	-6.49	36.89	46.00	-9.11	QP
5		530.1014	25.91	4.02	29.93	46.00	-16.07	QP
6		827.4934	26.08	6.67	32.75	46.00	-13.25	QP

The test result is calculated as the following:

- (1) Result = Reading + Correct Factor
- (2) Correct Factor = Antenna Factor + Cable Loss – Amplifier Gain + Attenuator
- (3) Margin = Result - Limit

TEST RESULTS (Above 1000 MHz)

EUT:	TrekStor SurfTab theatre K13	Model No.:	TFMTKAW01216
Temperature:	24°C	Relative Humidity:	55%
Distance:	3m	Test Power:	120V 60Hz
Polarization:		Test Result:	Pass
Test Mode:	TX-802.11a	Test By:	Smile

Above 1GHz:

Mode	Polar (H/V)	Frequency (MHz)	Reading (dBμV)	Factor (dB)	Result (dBμV)	Limit (dBμV/m)	Margin (dB)	Detector (PK/AV)
802.11a-5180MHz	H	10360	34.78	12.56	47.34	74.00	-26.66	PEAK
	H	15540	36.01	16.45	52.46	74.00	-21.54	PEAK
	V	10360	35.41	12.56	47.97	74.00	-26.03	PEAK
	V	15540	36.46	16.45	52.91	74.00	-21.09	PEAK

802.11a-5200 MHz	H	10400	36.02	12.64	48.66	74.00	-25.34	PEAK
	H	15600	35.42	16.53	51.95	74.00	-22.05	PEAK
	V	10400	36.97	12.64	49.61	74.00	-24.39	PEAK
	V	15600	35.68	16.53	52.21	74.00	-21.79	PEAK

802.11a-5240 MHz	H	10480	33.78	12.68	46.46	74.00	-27.54	PEAK
	H	15720	34.61	16.54	51.15	74.00	-22.85	PEAK
	V	10480	36.16	12.68	48.84	74.00	-25.16	PEAK
	V	15720	33.84	16.54	50.38	74.00	-23.62	PEAK

Mode	Polar (H/V)	Frequency (MHz)	Reading (dBμV)	Factor (dB)	Result (dBμV)	Limit (dBμV/m)	Margin (dB)	Detector (PK/AV)
802.11n HT20-5180MHz	H	10360	32.68	12.56	45.24	74.00	-28.76	PEAK
	H	15540	35.03	16.45	51.48	74.00	-22.52	PEAK
	V	10360	35.35	12.56	47.91	74.00	-26.09	PEAK
	V	15540	36.01	16.45	52.46	74.00	-21.54	PEAK

802.11n HT20-5200MHz	H	10400	35.05	12.64	47.69	74.00	-26.31	PEAK
	H	15600	33.62	16.53	50.15	74.00	-23.85	PEAK
	V	10400	35.83	12.64	48.47	74.00	-25.53	PEAK
	V	15600	36.02	16.53	52.55	74.00	-21.45	PEAK

802.11n HT20-5240MHz	H	10480	34.44	12.68	47.12	74.00	-26.88	PEAK
	H	15720	32.02	16.54	48.56	74.00	-25.44	PEAK
	V	10480	34.14	12.68	46.82	74.00	-27.18	PEAK
	V	15720	33.08	16.54	49.62	74.00	-24.38	PEAK

802.11n HT40-5190MHz	H	10380	35.45	12.58	48.03	74.00	-25.97	PEAK
	H	15570	34.36	16.48	50.84	74.00	-23.16	PEAK
	V	10380	37.10	12.58	49.68	74.00	-24.32	PEAK
	V	15570	33.47	16.48	49.95	74.00	-24.05	PEAK

Mode	Polar (H/V)	Frequency (MHz)	Reading (dB μ V)	Factor (dB)	Result (dB μ V)	Limit (dB μ V/m)	Margin (dB)	Detector (PK/AV)
802.11n HT40-5230MHz	H	10460	36.71	12.66	49.37	74.00	-24.63	PEAK
	H	15690	35.15	16.53	51.68	74.00	-22.32	PEAK
	V	10460	36.09	12.66	48.75	74.00	-25.25	PEAK
	V	15690	33.88	16.53	50.41	74.00	-23.59	PEAK

802.11ac HT20-5180MHz	H	10360	34.69	12.56	47.25	74.00	-26.75	PEAK
	H	15540	33.49	16.45	49.94	74.00	-24.06	PEAK
	V	10360	33.66	12.56	46.22	74.00	-27.78	PEAK
	V	15540	34.35	16.45	50.80	74.00	-23.20	PEAK

802.11ac HT20-5200MHz	H	10400	34.26	12.64	46.90	74.00	-27.10	PEAK
	H	15600	31.06	16.53	47.59	74.00	-26.41	PEAK
	V	10400	32.94	12.64	45.58	74.00	-28.42	PEAK
	V	15600	31.79	16.53	48.32	74.00	-25.68	PEAK

802.11ac HT20-5240MHz	H	10480	33.54	12.68	46.22	74.00	-27.78	PEAK
	H	15720	32.72	16.54	49.26	74.00	-24.74	PEAK
	V	10480	31.97	12.68	44.65	74.00	-29.35	PEAK
	V	15720	33.78	16.54	50.32	74.00	-23.68	PEAK

802.11ac HT40-5190MHz	H	10380	33.44	12.58	46.02	74.00	-27.98	PEAK
	H	15570	34.88	16.48	51.36	74.00	-22.64	PEAK
	V	10380	35.14	12.58	47.72	74.00	-26.28	PEAK
	V	15570	32.49	16.48	48.97	74.00	-25.03	PEAK

802.11ac HT40-5230MHz	H	10460	34.08	12.66	46.74	74.00	-27.26	PEAK
	H	15690	32.18	16.53	48.71	74.00	-25.29	PEAK
	V	10460	34.29	12.66	46.95	74.00	-27.05	PEAK
	V	15690	33.26	16.53	49.79	74.00	-24.21	PEAK

The field strength is calculated by adding the Antenna Factor. Cable Factor & Preamplifier. The basic equation with a sample calculation is as follows:

Final Test Level = Receiver Reading + Antenna Factor + Cable Factor – Preamplifier Factor.

Average measurement was not performed if peak level lower than average limit.

No any other emissions level very low which are attenuated less than 20dB below the limit.

According to 15.31(o), The amplitude of spurious emissions from intentional radiators and emissions from unintentional radiators which are attenuated more than 20 dB below the permissible value need not be reported unless specifically required elsewhere in this Part.

Hence there no other emissions have been reported.

8. FREQUENCY STABILITY

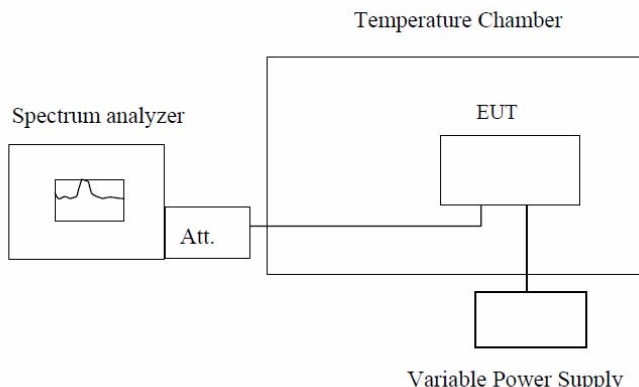
Test Requirement:	FCC Part15 C Section 15.407(g)
Test Method:	ANSI C63.10:2013, FCC Part 2.1055
Limit:	Manufactures of U-NII devices are responsible for ensuring frequency stability such that an emission is maintained within the band of operation under all conditions of normal operation as specified
Test Procedure:	The EUT was setup to ANSI C63.4, 2014; tested to 2.1055 for compliance to FCC Part 15.407(g) requirements.
Test setup:	 <p style="text-align: center;">Temperature Chamber</p> <p style="text-align: center;">Spectrum analyzer</p> <p style="text-align: center;">Att.</p> <p style="text-align: center;">EUT</p> <p style="text-align: center;">Variable Power Supply</p> <p>Note : Measurement setup for testing on Antenna connector</p>
Test Instruments:	Refer to section 5.10 for details
Test mode:	Refer to section 5.3 for details
Test results:	Pass

Frequency stability versus Temp.					
Power Supply: DC 3.8V					
Temp. (°C)	Operating Frequency (MHz)	0 minute	2 minute	5 minute	10 minute
		Measured Frequency (MHz)	Measured Frequency (MHz)	Measured Frequency (MHz)	Measured Frequency (MHz)
-30	5180	5176.0390	5182.9377	5181.3205	5177.8383
	5200	5198.5140	5202.5670	5202.1440	5199.2526
	5220	5219.6366	5220.2274	5221.2324	5219.8565
	5240	5240.0047	5240.7024	5240.1155	5239.6895
-20	5180	5179.9075	5180.3537	5180.7217	5179.9932
	5200	5199.5517	5200.3762	5200.1618	5199.7432
	5220	5219.3799	5220.5356	5220.1778	5219.7812
	5240	5239.3587	5240.2335	5240.5955	5239.1710
-10	5180	5178.9359	5180.2743	5180.0819	5179.1462
	5200	5199.9667	5200.8368	5200.9360	5199.1854
	5220	5219.7233	5220.7293	5220.1756	5219.4306
	5240	5239.3781	5240.6033	5240.9213	5239.2548
0	5180	5180.0628	5180.4624	5180.3167	5179.2180
	5200	5199.3847	5200.6652	5200.8476	5199.9342
	5220	5219.1379	5219.8924	5219.9476	5220.0182
	5240	5239.3749	5240.7739	5240.1505	5239.4927

10	5180	5179.2044	5180.1324	5180.9646	5179.2571
	5200	5199.5195	5200.0978	5200.6436	5199.7502
	5220	5219.1109	5220.2076	5220.0442	5219.8922
	5240	5239.0104	5240.4772	5240.5896	5239.5338
20	5180	5179.8356	5180.0985	5180.4673	5179.4308
	5200	5199.6485	5200.2917	5200.8166	5199.3597
	5220	5219.3707	5220.7472	5220.4631	5219.6538
	5240	5239.1146	5240.8429	5240.3029	5239.3407
30	5180	5179.7134	5180.7765	5180.2574	5179.7396
	5200	5199.2393	5200.1932	5200.3864	5199.7187
	5220	5219.3928	5220.3949	5220.9855	5219.4535
	5240	5239.6162	5240.3360	5240.7342	5240.0298
40	5180	5179.7188	5180.5875	5180.2308	5180.0856
	5200	5199.4303	5200.8142	5200.9014	5199.7659
	5220	5219.3310	5220.5280	5220.6542	5219.6334
	5240	5239.1477	5240.8400	5240.7104	5240.0589
50	5180	5179.3587	5180.5822	5180.5126	5179.1265
	5200	5199.3657	5200.8424	5200.2228	5199.2232
	5220	5219.6881	5220.7831	5220.4358	5219.4252
	5240	5239.5172	5240.3246	5239.9505	5239.2891

Frequency stability versus Voltage					
Temperature: 25°C					
Power Supply (VDC)	Operating Frequency (MHz)	0 minute	2 minute	5 minute	10 minute
		Measured Frequency (MHz)	Measured Frequency (MHz)	Measured Frequency (MHz)	Measured Frequency (MHz)
3.4	5180	5183.8496	5182.0430	5176.4893	5178.4145
	5200	5203.8755	5200.2352	5196.6995	5197.9040
	5220	5220.9170	5220.2980	5217.4327	5219.8648
	5240	5240.6685	5240.7747	5238.4541	5239.5367
3.8	5180	5181.0943	5180.2876	5179.2108	5179.2870
	5200	5200.1590	5200.6411	5199.7789	5199.2467
	5220	5221.0659	5220.3451	5219.8550	5219.6150
	5240	5240.1156	5240.9039	5239.3827	5239.7562
4.2	5180	5180.2240	5180.5997	5179.2547	5179.2968
	5200	5200.3143	5200.5594	5199.2209	5199.3651
	5220	5219.9217	5220.7679	5219.1445	5219.2976
	5240	5240.7837	5240.3834	5239.5970	5239.0315

POWER LINE CONDUCTED EMISSION

9.1 Test equipment

Item	Kind of Equipment	Manufacturer	Type No.	Serial No.	Calibrated until
1	Pulse Limiter	MTS-systemtechnik	MTS-IMP-136	261115-010-0024	12/17/2018
2	EMI Test Receiver	R&S	ESCI	101308	12/17/2018
3	LISN	AFJ	LS16	16011103219	12/17/2018
4	LISN	Schwarzbeck	NSLK 8127	8127-432	12/17/2018
5	Measurement Software	Farad	EZ-EMC (Ver.ATT-03A)	N/A	N/A
6	MeasurementSoftware	Farad	EZ-EMC (Ver.ATT-03A)	N/A	N/A

9.2 Block diagram of test setup

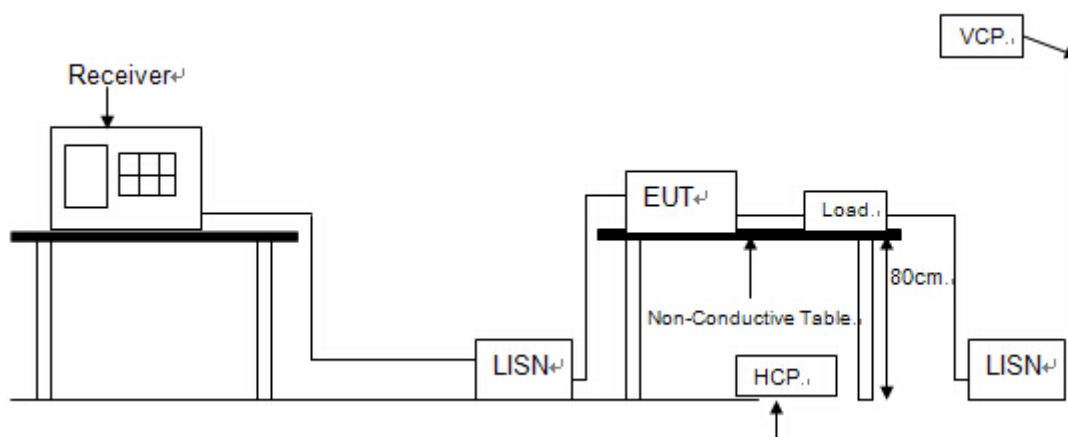

9.3 Power Line Conducted Emission Limits(Class B)

Frequency	Quasi-Peak Level dB(μ V)	Average Level dB(μ V)
150kHz ~ 500kHz	66 ~ 56*	56 ~ 46*
500kHz ~ 5MHz	56	46
5MHz ~ 30MHz	60	50

Note 1: * Decreasing linearly with logarithm of frequency.

Note 2: The lower limit shall apply at the transition frequencies.

9.4 TEST PROCEDURE

The EUT and Support equipment, if needed, were put placed on a non-metallic table, 80cm above the ground plane.

Configuration EUT to simulate typical usage as described in clause 2.4 and test equipment as described in clause 10.2 of this report.

All I/O cables were positioned to simulate typical actual usage as per ANSI C63.4.

All support equipment power received from a second LISN.

Emissions were measured on each current carrying line of the EUT using an EMI Test Receiver connected to the LISN powering the EUT.

The Receiver scanned from 150 kHz to 30MHz for emissions in each of the test modes.

During the above scans, the emissions were maximized by cable manipulation.

The test mode(s) described in clause 2.4 were scanned during the preliminary test.

After the preliminary scan, we found the test mode producing the highest emission level.

The EUT configuration and worse cable configuration of the above highest emission levels were recorded for reference of the final test.

EUT and support equipment were set up on the test bench as per the configuration with highest emission level in the preliminary test.

A scan was taken on both power lines, Neutral and Line, recording at least the six highest emissions.

Emission frequency and amplitude were recorded into a computer in which correction factors were used to calculate the emission level and compare reading to the applicable limit.

The test data of the worst-case condition(s) was recorded.

The bandwidth of test receiver is set at 9 KHz.

9.5 Test Result

PASS. (See below detailed test result)

Note1: All emissions not reported below are too low against the prescribed limits.

Note2: "-----" means peak detection; "-----" mans average detection

EUT:	Table PC	Model No.:	TFMTKAW01216
Temperature:	23°C	Relative Humidity:	52%
Probe:	N	Test Power:	AC 120V/60Hz
Test Time:	2018-10-17	Test Result:	Pass
Standard:	(CE)FCC PART 15 class B_QP		
Test Mode:	TX		
Note:			

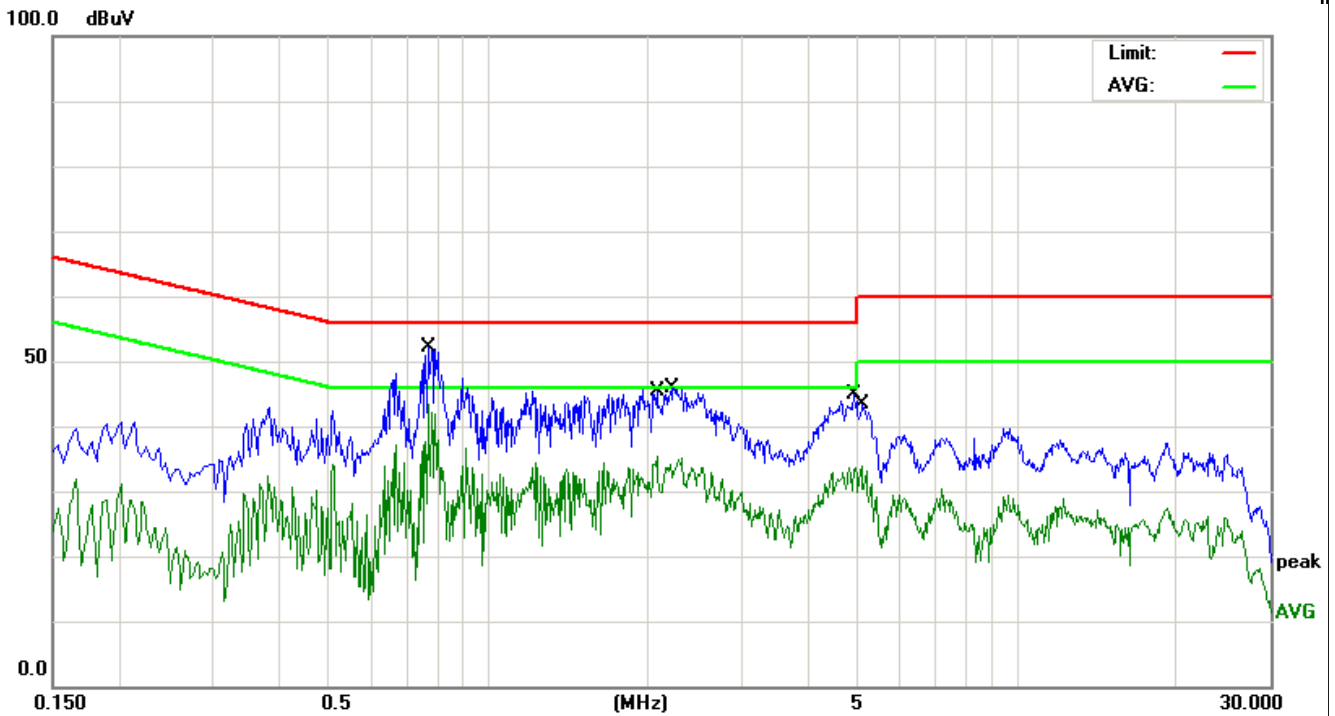

No.	Mk.	Freq.	Reading Level	Correct Factor	Measurement	Limit	Over	Detector
		MHz	dBuV	dB	dBuV	dBuV	dB	
1	*	0.7700	42.25	9.97	52.22	56.00	-3.78	QP
2		0.7700	28.33	9.97	38.30	46.00	-7.70	AVG
3		2.0820	25.29	9.99	35.28	46.00	-10.72	AVG
4		2.2300	35.81	10.00	45.81	56.00	-10.19	QP
5		4.9220	34.73	10.11	44.84	56.00	-11.16	QP
6		5.0620	23.77	10.11	33.88	50.00	-16.12	AVG

The test result is calculated as the following:

- (1) Result = Reading + Correct Factor
- (2) Correct Factor = (LISN, ISN, PLC or Current Probe) Factor + Cable Loss + Attenuator
- (3) Margin = Result - Limit

EUT:	Table PC	Model No.:	TFMTKAW01216
Temperature:	23°C	Relative Humidity:	52%
Probe:	L1	Test Power:	AC 120V/60Hz
Test Time:	2018-10-17	Test Result:	Pass
Standard:	(CE)FCC PART 15 class B_QP		
Test Mode:	TX		
Note:			

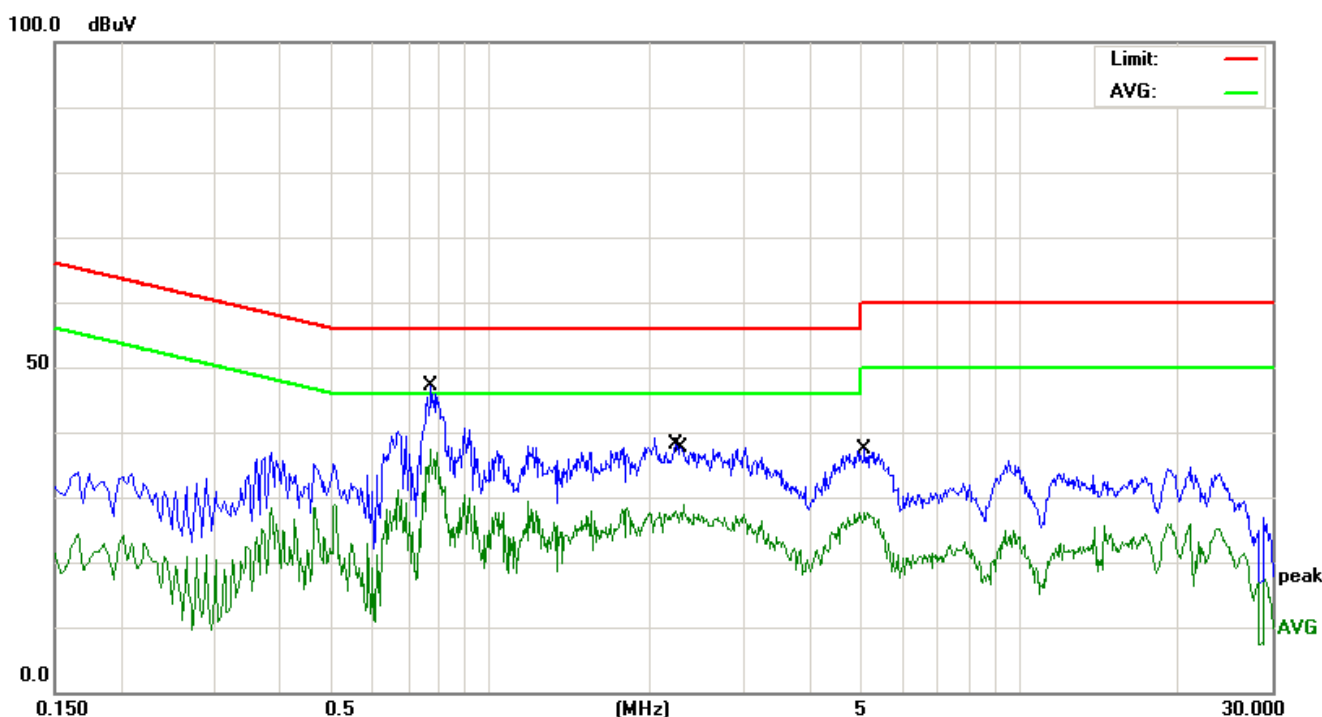

No.	Mk.	Freq.	Reading Level	Correct Factor	Measurement	Limit	Over	Detector
		MHz	dBuV	dB	dBuV	dBuV	dB	
1	*	0.7700	27.34	9.97	37.31	46.00	-8.69	AVG
2		0.7740	37.10	9.97	47.07	56.00	-8.93	QP
3		2.2380	28.14	10.00	38.14	56.00	-17.86	QP
4		2.3179	18.93	10.00	28.93	46.00	-17.07	AVG
5		5.0860	27.27	10.11	37.38	60.00	-22.62	QP
6		5.0860	17.48	10.11	27.59	50.00	-22.41	AVG

The test result is calculated as the following:

- (1) Result = Reading + Correct Factor
- (2) Correct Factor = (LISN, ISN, PLC or Current Probe) Factor + Cable Loss + Attenuator
- (3) Margin = Result - Limit

9. ANTENNA REQUIREMENTS

9.1. Limit

15.203 requirement: For intentional device, according to 15.203: an intentional radiator shall be designed to ensure that no antenna other than that furnished by the responsible party shall be used with the device.

9.2. EUT ANTENNA

The EUT antenna is permanent attached antenna. It comply with the standard requirement.