



## **Installation and Commissioning Procedure**

**For iSLC3100-7P-C**

CIMCON Lighting, Inc.

iSLC3100-7P-C

---

Place the Photocontroller into the 7-pin NEMA receptacle and rotate it clockwise to lock.



Fig. 1 Installation of iSLC3100-7P-C on the luminaire

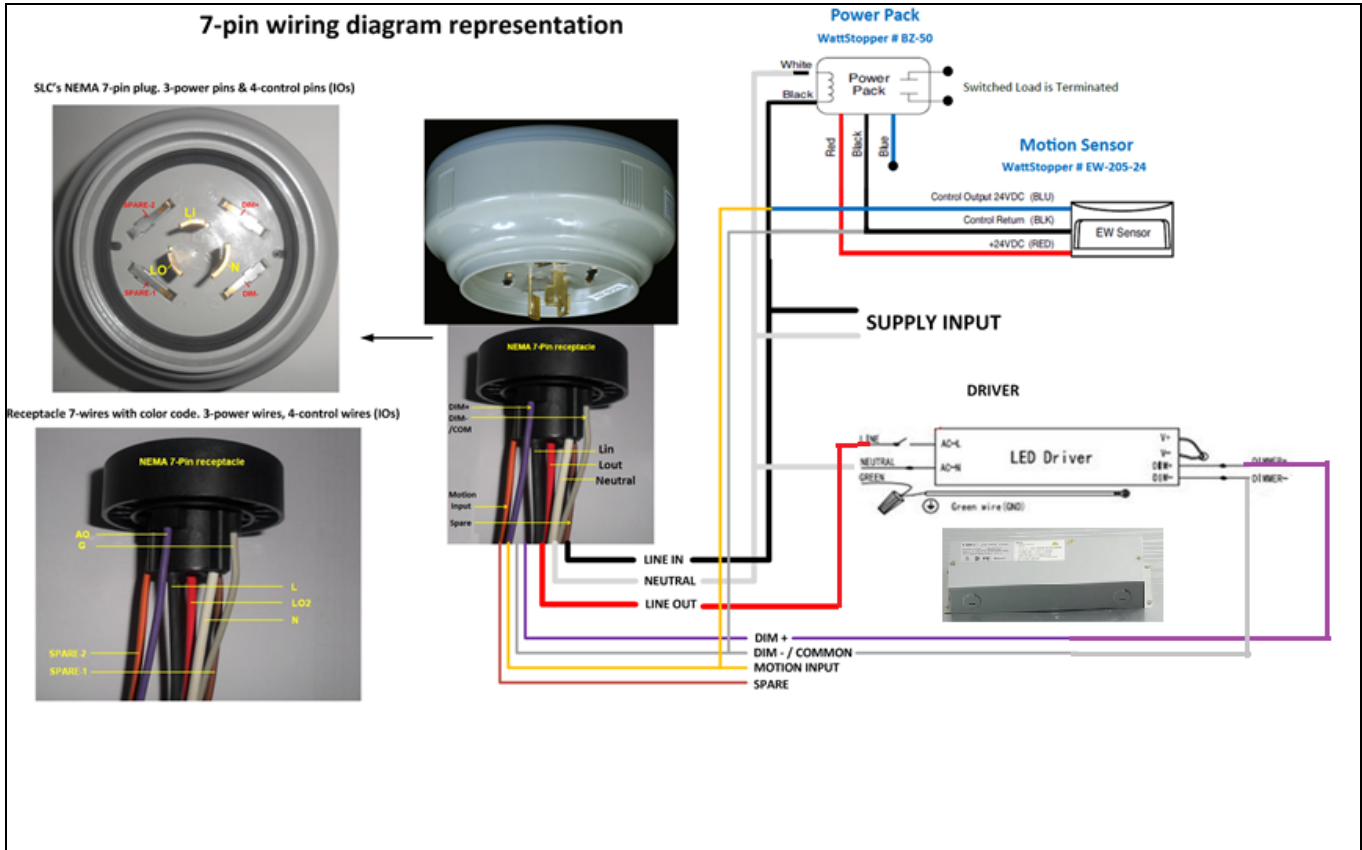
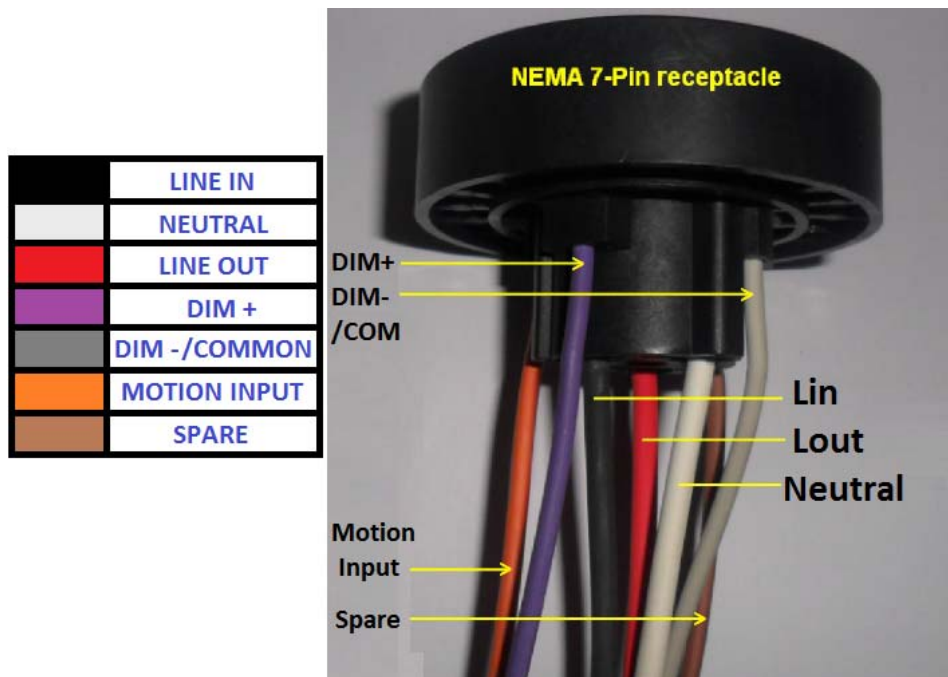

Fig. 2: Installation wiring diagram

The cables protruding from the receptacle have following function as mentioned into table.



Once the Photo-controller is installed and luminaire is powered ON then depending on the daylight condition Lamp will operate. In the Lab environment, you can just cover the cap with cloth or by hand and see the Lamp turning ON if wired correctly and if you remove the cloth, it will turn OFF.

### Safety Consideration for the Installation crew:

- Ensure that the supply voltage matches the SLC's voltage rating.
- Firmly place the SLC into the NEMA twist lock receptacle/socket on top of the fixture by aligning the large prong on the SLC with the large opening in the receptacle/socket. Push down on SLC and twist clockwise until it locks into place.
- PHOTOCONTROL MUST BE LOCKED IN! Note: window or arrow on top of SLC should be pointed away from the mounting surface. The receptacle/socket may be repositioned by loosening the screw in the center of the receptacle/socket. Rotate to the new position and retighten screw. Do not rotate receptacle/socket over 360 degrees because you can twist receptacle/socket wires. Eventually stripping the insulation and cause the fixture to fail.
- To check operation during the daylight hours, cover the SLC's photocell window (or top surface) completely to simulate darkness.

## FCC Warning statement

### 15.19.

- This device complies with Part 15 of the FCC Rules. Operation is subject to the following two conditions: (1) this device may not cause harmful interference, and (2) this device must accept any interference received, including interference that may cause undesired operation.
- Any changes or modifications not expressly approved by the party responsible for compliance could void the authority to operate equipment.
- This device and its antenna must not be co-located or operating in conjunction with any other antenna or transmitter.
- End-users and installers must be provided with antenna installation instructions and transmitter operating conditions for satisfying RF exposure compliance.

This equipment has been tested and found to comply with the limits for a Class B digital device, pursuant to part 15 of the FCC Rules. These limits are designed to provide reasonable protection against harmful interference in a residential installation. This equipment generates, uses and can radiate radio frequency energy and, if not installed and used in accordance with the instructions, may cause harmful interference to radio communications. However, there is no guarantee that interference will not occur in a particular installation. If this equipment does cause harmful interference to radio or television reception, which can be determined by turning the equipment off and on, the user is encouraged to try to correct the interference by one or more of the following measures:

- Reorient or relocate the receiving antenna.
- Increase the separation between the equipment and receiver.
- Connect the equipment into an outlet on a circuit different from that to which the receiver is connected.
- Consult the dealer or an experienced radio/TV technician for help.

### FCC RF Radiation Exposure Statement:

#### Mobile Device

This equipment complies with FCC radiation exposure limits set forth for an uncontrolled environment. This equipment should be installed and operated with minimum distance 20cm between the radiator & your body.