

# MEASUREMENT REPORT

## FCC PART 15.247 Bluetooth-LE

---

**FCC ID:** 2ALS8-SS0001

**Applicant:** Ninebot (Changzhou) Tech Co., Ltd.

**Product:** Ninebot Telematics Box

**Model No.:** N-D-W75NL-U

**Brand Name:** Ninebot

**FCC Classification:** Digital Transmission System (DTS)

**FCC Rule Part(s):** Part15 Subpart C (Section 15.247)

**Test Procedure(s):** ANSI C63.10-2013

**Test Date:** June 22 ~ 24, 2021

**Reviewed By:**

\_\_\_\_\_  
Vincent Yu

**Approved By:**

\_\_\_\_\_  
Robin Wu



The test results relate only to the samples tested.

This equipment has been shown to be capable of compliance with the applicable technical standards as indicated in the measurement report and was tested in accordance with the measurement procedures specified in ANSI C63.10-2013. Test results reported herein relate only to the item(s) tested.

The test report shall not be reproduced except in full without the written approval of MRT Technology (Suzhou) Co., Ltd.

---

## Revision History

Report No.	Version	Description	Issue Date	Note
2106RSU025-U1	Rev. 01	Initial Report	10-18-2021	Valid

---

## CONTENTS

Description	Page
<b>1. GENERAL INFORMATION .....</b>	<b>5</b>
1.1. Applicant .....	5
1.2. Manufacturer .....	5
1.3. Testing Facility.....	5
<b>2. PRODUCT INFORMATION .....</b>	<b>6</b>
2.1. Equipment Description .....	6
2.2. Product Specification Subjective to this Report .....	6
2.3. Working Frequencies for this report.....	6
2.4. Test Mode .....	7
2.5. Test Software .....	7
2.6. Test Environment Condition.....	7
2.7. Duty Cycle.....	7
<b>3. ANTENNA REQUIREMENTS.....</b>	<b>8</b>
<b>4. TEST EQUIPMENT CALIBRATION DATE.....</b>	<b>9</b>
<b>5. MEASUREMENT UNCERTAINTY .....</b>	<b>11</b>
<b>6. TEST RESULT .....</b>	<b>12</b>
6.1. Summary.....	12
6.2. Occupied Bandwidth Measurement.....	13
6.2.1. Test Limit .....	13
6.2.2. Test Procedure used.....	13
6.2.3. Test Setting.....	13
6.2.4. Test Setup .....	13
6.2.5. Test Result.....	14
6.3. Output Power Measurement.....	15
6.3.1. Test Limit .....	15
6.3.2. Test Procedure Used .....	15
6.3.3. Test Setting.....	15
6.3.4. Test Setup .....	16
6.3.5. Test Result.....	17
6.4. Power Spectral Density Measurement.....	18
6.4.1. Test Limit .....	18
6.4.2. Test Procedure Used .....	18
6.4.3. Test Setting.....	18
6.4.4. Test Setup .....	18

---

6.4.5.	Test Result.....	19
6.5.	Conducted Band Edge and Out-of-Band Emissions .....	20
6.5.1.	Test Limit .....	20
6.5.2.	Test Procedure Used .....	20
6.5.3.	Test Setting.....	20
6.5.4.	Test Setup .....	21
6.5.5.	Test Result.....	22
6.6.	Radiated Spurious Emission Measurement .....	24
6.6.1.	Test Limit .....	24
6.6.2.	Test Procedure Used .....	24
6.6.3.	Test Setting.....	24
6.6.4.	Test Setup .....	26
6.6.5.	Test Result.....	27
6.7.	Radiated Restricted Band Edge Measurement.....	32
6.7.1.	Test Limit .....	32
6.7.2.	Test Procedure Used .....	33
6.7.3.	Test Setting.....	33
6.7.4.	Test Setup .....	34
6.7.5.	Test Result.....	35
6.8.	AC Conducted Emissions Measurement .....	43
6.8.1.	Test Limit .....	43
6.8.2.	Test Setup .....	43
6.8.3.	Test Result.....	43
<b>7.</b>	<b>CONCLUSION .....</b>	<b>44</b>
	<b>Appendix A - Test Setup Photograph .....</b>	<b>45</b>
	<b>Appendix B - EUT Photograph.....</b>	<b>46</b>



## 2. PRODUCT INFORMATION

### 2.1. Equipment Description

Product Name	Ninebot Telematics Box
Model No.	N-D-W75NL-U
Brand Name	Ninebot

### 2.2. Product Specification Subjective to this Report

Bluetooth Specification	V5.1 (BLE Only)
Frequency Range	2402 ~ 2480MHz
Channel Number	40
Type of Modulation	GFSK
Data Rate	1Mbps
Antenna Type	PCB Antenna
Antenna Gain	-1.26dBi

Note: For other features of this EUT, test report will be issued separately.

### 2.3. Working Frequencies for this report

Channel	Frequency	Channel	Frequency	Channel	Frequency
00	2402 MHz	01	2404 MHz	02	2406 MHz
03	2408 MHz	04	2410 MHz	05	2412 MHz
06	2414 MHz	07	2416 MHz	08	2418 MHz
09	2420 MHz	10	2422 MHz	11	2424 MHz
12	2426 MHz	13	2428 MHz	14	2430 MHz
15	2432 MHz	16	2434 MHz	17	2436 MHz
18	2438 MHz	19	2440 MHz	20	2442 MHz
21	2444 MHz	22	2446 MHz	23	2448 MHz
24	2450 MHz	25	2452 MHz	26	2454 MHz
27	2456 MHz	28	2458 MHz	29	2460 MHz
30	2462 MHz	31	2464 MHz	32	2466 MHz
33	2468 MHz	34	2470 MHz	35	2472 MHz
36	2474 MHz	37	2476 MHz	38	2478 MHz
39	2480 MHz	--	--	--	--

## 2.4. Test Mode

Test Mode	Mode 1: Transmit by BLE
-----------	-------------------------

## 2.5. Test Software

The test utility software used during testing was “DTM.exe”, and the version was 1.2.31.

## 2.6. Test Environment Condition

Ambient Temperature	15°C~35°C
Relative Humidity	20%RH ~75%RH

## 2.7. Duty Cycle

Bluetooth-LE (DTS) operation is possible in channel bandwidths. The maximum achievable duty cycles for all modes were determined based on measurements performed on a spectrum analyzer in zero-span mode with RBW = 8MHz, VBW = 50MHz. The RBW and VBW were both greater than  $50/T$ , where T is the minimum transmission duration, and the number of sweep points across T was greater than 100. The duty cycles are as follows:

Test Mode	Duty Cycle
BLE	11.15%

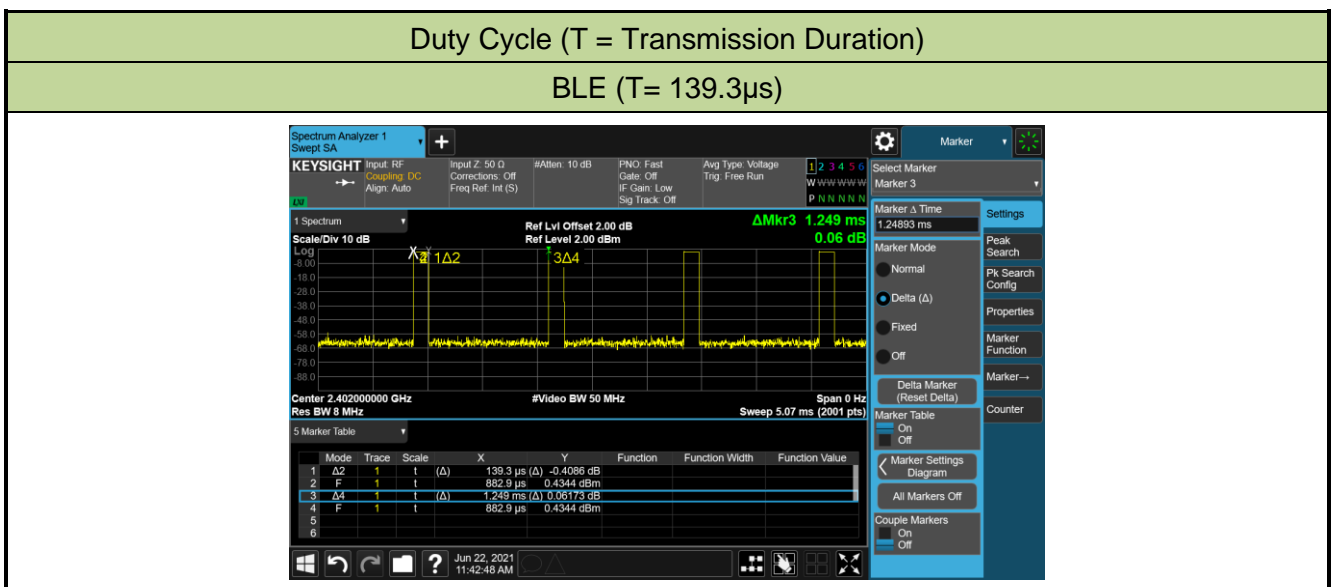

### 3. ANTENNA REQUIREMENTS

**Excerpt from §15.203 of the FCC Rules/Regulations:**

“An intentional radiator antenna shall be designed to ensure that no antenna other than that furnished by the responsible party can be used with the device. The use of a permanently attached antenna or of an antenna that uses a unique coupling to the intentional radiator shall be considered sufficient to comply with the provisions of this section.”

- The antenna of this device is **permanently attached**.
- There are no provisions for connection to an external antenna.

**Conclusion:**

The unit complies with the requirement of §15.203.



#### 4. TEST EQUIPMENT CALIBRATION DATE

##### Conducted Emission (WZ-SR2)

Instrument	Manufacturer	Type No.	Asset No.	Cali. Interval	Cali. Due Date
EMI Test Receiver	R&S	ESR3	MRTSUE06909	1 year	2021/11/22
Two-Line V-Network	R&S	ENV216	MRTSUE06002	1 year	2022/06/08
Thermal Hygrometer	testo	608-H1	MRTSUE06404	1 year	2021/07/26
					2022/06/28
Shielding Room	MIX-BEP	Chamber-SR2	MRTSUE06215	N/A	N/A

##### Radiated Emission (WZ-AC1)

Instrument	Manufacturer	Type No.	Asset No.	Cali. Interval	Cali. Due Date
EMI Test Receiver	R&S	ESR7	MRTSUE06001	1 year	2022/01/04
Loop Antenna	Schwarzbeck	FMZB 1519	MRTSUE06025	1 year	2021/11/08
Bilog Period Antenna	Schwarzbeck	VULB 9168	MRTSUE06172	1 year	2021/08/08
Horn Antenna	Schwarzbeck	BBHA 9120D	MRTSUE06023	1 year	2021/09/27
Horn Antenna	Schwarzbeck	BBHA9170	MRTSUE06597	1 year	2021/12/14
Microwave System Amplifier	Agilent	83017A	MRTSUE06076	1 year	2021/11/14
Preamplifier	Schwarzbeck	BBV 9721	MRTSUE06121	1 year	2022/06/09
Thermal Hygrometer	testo	608-H1	MRTSUE06403	1 year	2021/07/26
					2022/06/28
Anechoic Chamber	TDK	Chamber-AC1	MRTSUE06212	1 year	2022/04/29

##### Radiated Emission (WZ-AC2)

Instrument	Manufacturer	Type No.	Asset No.	Cali. Interval	Cali. Due Date
MXE EMI Receiver	Keysight	N9038A	MRTSUE06125	1 year	2021/07/02
					2022/06/24
Loop Antenna	Schwarzbeck	FMZB 1519	MRTSUE06025	1 year	2021/11/08
Bilog Period Antenna	Schwarzbeck	VULB 9162	MRTSUE06022	1 year	2022/05/24
Broad-Band Horn Antenna	Schwarzbeck	BBHA 9120D	MRTSUE06171	1 year	2021/10/25
Horn Antenna	Schwarzbeck	BBHA9170	MRTSUE06597	1 year	2021/12/14
Broadband Coaxial Preamplifier	Schwarzbeck	BBV 9718	MRTSUE06176	1 year	2021/11/14
Thermal Hygrometer	Minggao	ETH529	MRTSUE06170	1 year	2021/12/08
Anechoic Chamber	RIKEN	Chamber-AC2	MRTSUE06213	1 year	2022/04/29

## Conducted Test Equipment (WZ-TR3)

Instrument	Manufacturer	Type No.	Asset No.	Cali. Interval	Cali. Due Date
EXA Signal Analyzer	Agilent	N9020A	MRTSUE06106	1 year	2022/04/13
EXA Signal Analyzer	Keysight	N9010B	MRTSUE06607	1 year	2022/01/06
Power Meter	Agilent	U2021XA	MRTSUE06030	1 year	2021/10/22
USB wideband power sensor	Keysight	U2021XA	MRTSUE06446	1 year	2022/06/08
USB wideband power sensor	Keysight	U2021XA	MRTSUE06447	1 year	2022/06/08
Bluetooth Test Set	Anritsu	MT8852B-042	MRTSUE06389	1 year	2022/06/08
Modulation Analyzer	HP	HP8901A	MRTSUE06098	1 year	2021/09/26
DC Power Supply	GWINSTEK	DPS-3303C	MRTSUE06064	N/A	N/A
Temperature & Humidity Chamber	BAOYT	BYH-150CL	MRTSUE06051	1 year	2021/10/22
Thermal Hygrometer	testo	608-H1	MRTSUE06401	1 year	2022/06/28

Software	Version	Function
EMI Software	V3	EMI Test Software

## 5. MEASUREMENT UNCERTAINTY

Where relevant, the following test uncertainty levels have been estimated for tests performed on the EUT as specified in CISPR 16-4-2. This uncertainty represents an expanded uncertainty expressed at approximately the 95% confidence level using a coverage factor of  $k = 2$ .

<b>Conducted Emission Measurement</b>
Measurement Uncertainty for a Level of Confidence of 95% ( $U=2Uc(y)$ ): 9kHz~150kHz: 3.74dB 150kHz~30MHz: 3.44dB
<b>Radiated Emission Measurement</b>
Measurement Uncertainty for a Level of Confidence of 95% ( $U=2Uc(y)$ ): Horizontal: 9KHz~300MHz: 5.04dB 300MHz~1GHz: 4.95dB 1GHz~6GHz: 6.40dB Vertical: 9KHz~300MHz: 5.24dB 300MHz~1GHz: 6.03dB 1GHz~40GHz: 6.40dB
<b>Spurious Emissions, Conducted</b>
Measuring Uncertainty for a Level of Confidence of 95% ( $U=2Uc(y)$ ): 0.78dB
<b>Output Power</b>
Measuring Uncertainty for a Level of Confidence of 95% ( $U=2Uc(y)$ ): 1.13dB
<b>Power Spectrum Density</b>
Measuring Uncertainty for a Level of Confidence of 95% ( $U=2Uc(y)$ ): 1.15dB
<b>Occupied Bandwidth</b>
Measuring Uncertainty for a Level of Confidence of 95% ( $U=2Uc(y)$ ): 0.28%

## 6. TEST RESULT

### 6.1. Summary

FCC Section(s)	Test Description	Test Limit	Test Condition	Test Result	Reference
15.247(a)(2)	6dB Bandwidth	$\geq 500\text{kHz}$	Conducted	Pass	Section 6.2
N/A	99% Bandwidth	N/A		Pass	
15.247(b)(3)	Output Power	$\leq 1\text{Watt (30dBm)}$ & $\text{EIRP} \leq 4\text{Watt (36dBm)}$		Pass	Section 6.3
15.247(e)	Power Spectral Density	$\leq 8\text{dBm/3kHz}$		Pass	Section 6.4
15.247(d)	Band Edge / Out-of-Band Emissions	20dBc		Pass	Section 6.5
15.205 15.209	General Field Strength Limits (Restricted Bands and Radiated Emission Limits)	Emissions in restricted bands must meet the radiated limits detailed in 15.209	Radiated	Pass	Section 6.6 & 6.7
15.207	AC Conducted Emissions 150kHz - 30MHz	< FCC 15.207 limits	Line Conducted	Pass	Section 6.8

#### Notes:

- 1) For radiated emission test, every axis (X, Y, Z) was also verified. The test results shown in the following sections represent the worst-case emissions.
- 2) The analyzer plots shown in this section were all taken with a correction table loaded into the analyzer. The correction table was used to account for the losses of the cables and attenuators used as part of the system to connect the EUT to the analyzer at all frequencies of interest.

## 6.2. Occupied Bandwidth Measurement

### 6.2.1. Test Limit

The minimum 6dB bandwidth shall be at least 500 kHz.

### 6.2.2. Test Procedure used

ANSI C63.10-2013 - Section 11.8

### 6.2.3. Test Setting

1. The Spectrum's automatic bandwidth measurement capability was used to perform the 6dB bandwidth measurement. The "X" dB bandwidth parameter was set to  $X = 6$ . The bandwidth measurement was not influenced by any intermediate power nulls in the fundamental emission.
2. Set RBW = 100 kHz
3.  $VBW \geq 3 \times RBW$
4. Detector = Peak
5. Trace mode = Max hold
6. Sweep = Auto couple
7. Allow the trace was allowed to stabilize

### 6.2.4. Test Setup

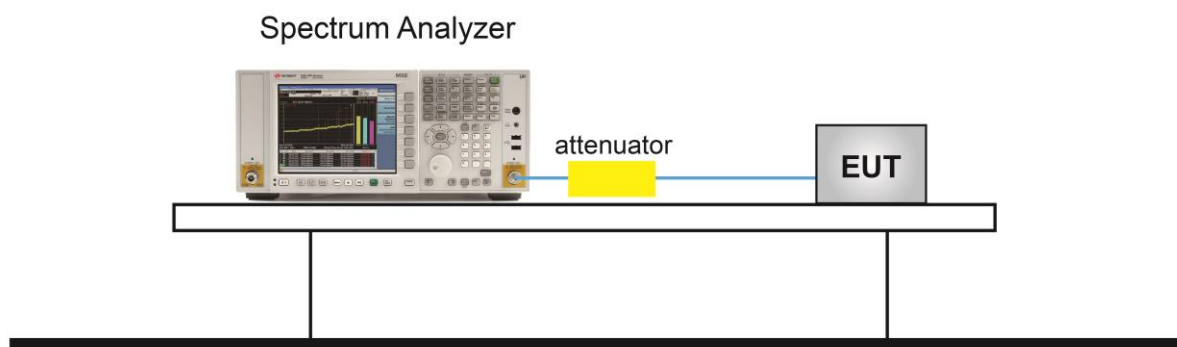

### 6.2.5. Test Result

Test Site	WZ-TR3	Test Engineer	Yuri Li
Test Date	2021/06/22		

Test Mode	Data Rate (Mbps)	Channel No.	Frequency (MHz)	6dB Bandwidth (KHz)	Limit (kHz)	Result
BLE	1	00	2402	654.6	≥ 500	Pass
BLE	1	19	2440	647.3	≥ 500	Pass
BLE	1	39	2480	659.6	≥ 500	Pass

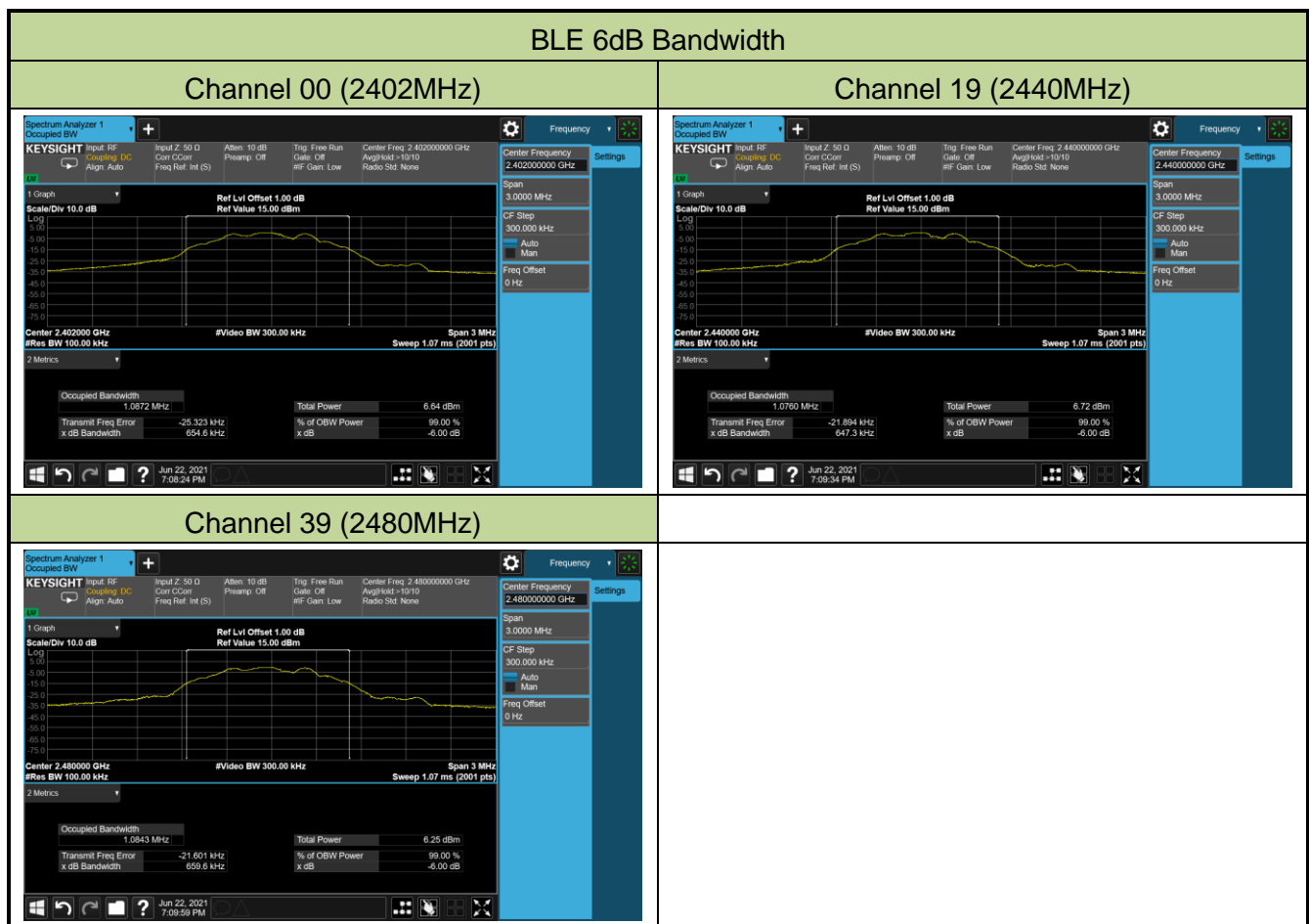

### **6.3. Output Power Measurement**

#### **6.3.1. Test Limit**

The maximum out power shall be less 1 Watt (30dBm).

The conducted output power limit specified in paragraph FCC Part 15.247(b) of this section is based on the use of antennas with directional gains that do not exceed 6 dBi. If transmitting antennas of directional gain greater than 6 dBi are used, the conducted output power from the intentional radiator shall be reduced below the stated values in paragraphs FCC Part 15.247(b)(3) of this section, as appropriate, by the amount in dB that the directional gain of the antenna exceeds 6 dBi.

#### **6.3.2. Test Procedure Used**

ANSI C63.10-2013 - Section 11.9.1.3 PKPM1 Peak-reading power meter method

ANSI C63.10-2013 - Section 11.9.2.3.2 Method AVGPM-G

#### **6.3.3. Test Setting**

##### **Method PKPM1 (Peak power measurement)**

Peak power measurements were performed only when the EUT was transmitting at its maximum power control level using a broadband power meter with a pulse sensor. The pulse sensor employs a VBW = 50MHz so this method was only used for signals whose DTS bandwidth was less than or equal to 50MHz.

##### **Method AVGPM-G (Measurement using a gated RF average-reading power meter)**

Measurements may be performed using a wideband gated RF power meter provided that the gate parameters are adjusted such that the power is measured only when the EUT is transmitting at its maximum power control level. Since this measurement is made only during the ON time of the transmitter, no duty cycle correction is required.

### 6.3.4. Test Setup

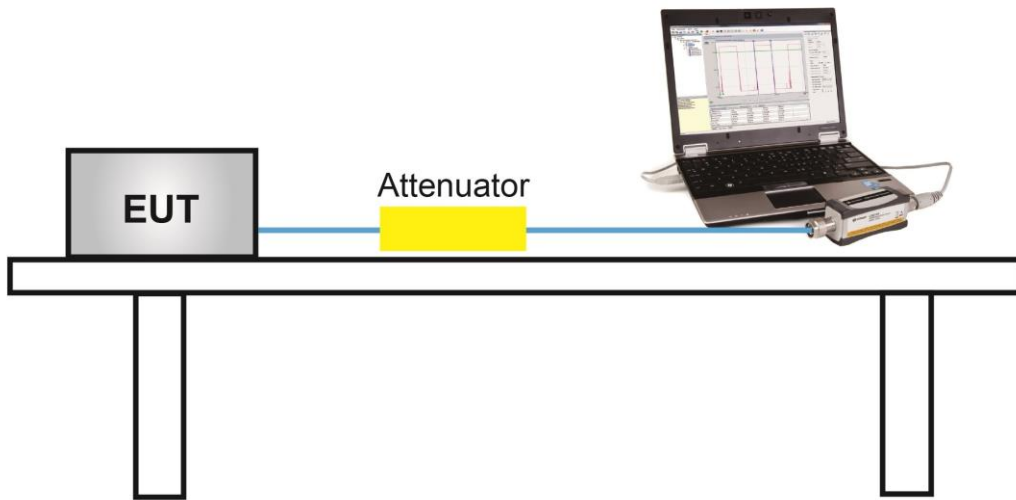



### 6.3.5. Test Result

Test Site	WZ-TR3	Test Engineer	Yuri Li
Test Date	2021/06/22		

#### Test Result of Peak Output Power

Test Mode	Data Rate (Mbps)	Channel No.	Frequency (MHz)	Peak Power (dBm)	Limit (dBm)	Result
BLE	1	00	2402	0.08	≤ 30.00	Pass
BLE	1	19	2440	0.07	≤ 30.00	Pass
BLE	1	39	2480	-0.18	≤ 30.00	Pass

#### Test Result of Average Output Power (Reporting Only)

Test Mode	Data Rate (Mbps)	Channel No.	Frequency (MHz)	Average Power (dBm)	Limit (dBm)	Result
BLE	1	00	2402	-0.27	≤ 30.00	Pass
BLE	1	19	2440	-0.29	≤ 30.00	Pass
BLE	1	39	2480	-1.16	≤ 30.00	Pass

## 6.4. Power Spectral Density Measurement

### 6.4.1. Test Limit

The maximum permissible power spectral density is 8dBm in any 3 kHz band.

The same method of determining the conducted output power shall be used to determine the power spectral density.

### 6.4.2. Test Procedure Used

ANSI C63.10-2013 - Section 11.10.2.

### 6.4.3. Test Setting

1. Analyzer was set to the center frequency of the DTS channel under investigation
2. Span = 1.5 times the DTS channel bandwidth
3. RBW = 3kHz
4. VBW = 10kHz
5. Detector = peak
6. Sweep time = auto couple
7. Trace mode = max hold
8. Trace was allowed to stabilize

### 6.4.4. Test Setup

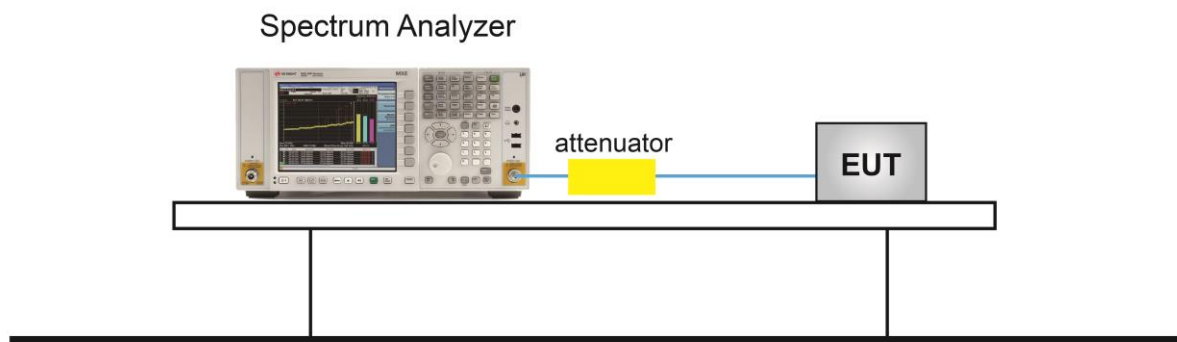

### 6.4.5. Test Result

Test Site	WZ-TR3	Test Engineer	Yuri Li
Test Date	2021/06/22		

Test Mode	Data Rate (Mbps)	Channel No.	Frequency (MHz)	PSD Result (dBm / 3kHz)	Limit (dBm / 3kHz)	Result
BLE	1	00	2402	-12.23	≤ 8.00	Pass
BLE	1	19	2440	-11.99	≤ 8.00	Pass
BLE	1	39	2480	-12.54	≤ 8.00	Pass

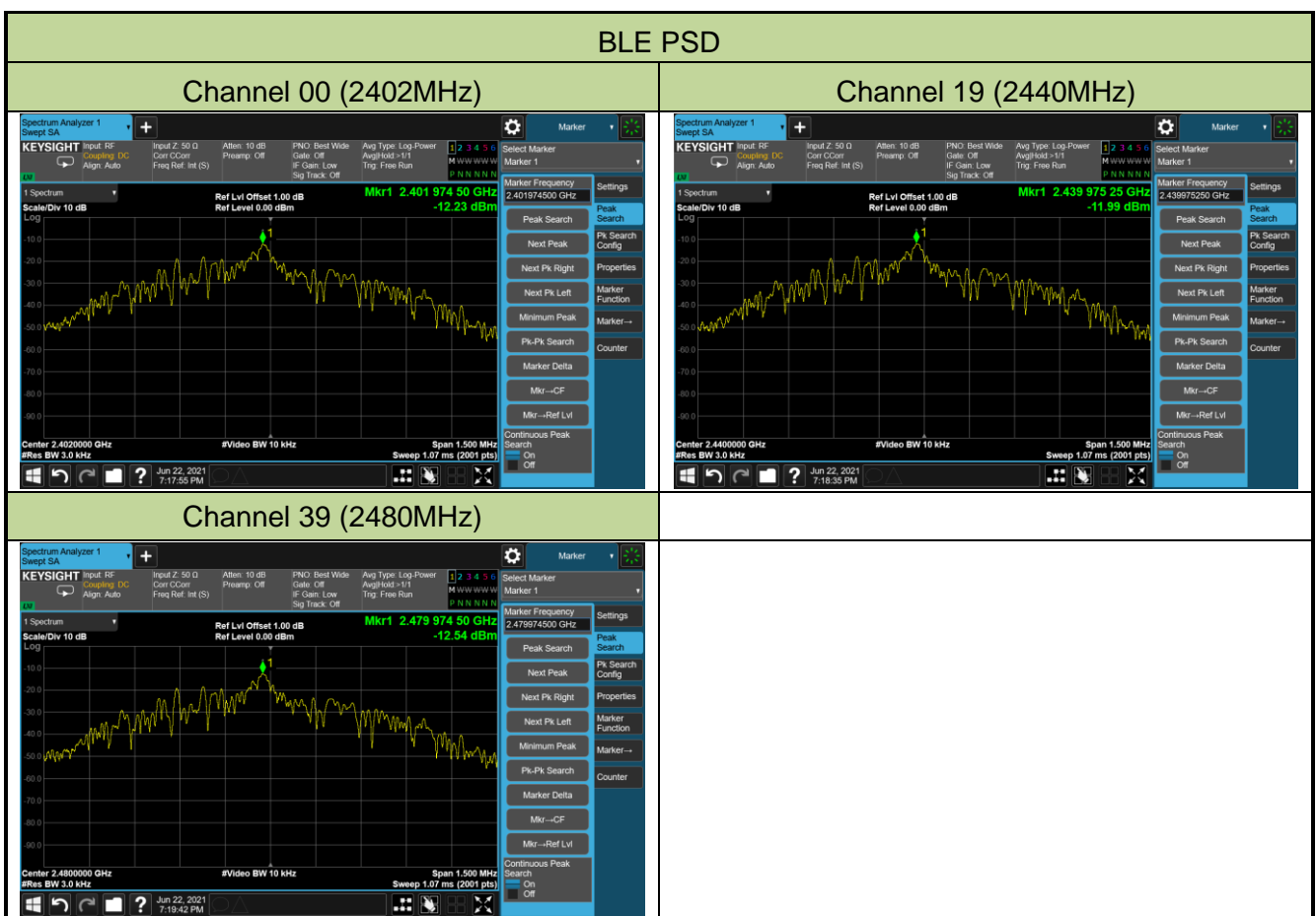

## **6.5. Conducted Band Edge and Out-of-Band Emissions**

### **6.5.1. Test Limit**

The limit for out-of-band spurious emissions at the band edge is 20dB below the fundamental emission level, as determined from the in-band power measurement of the DTS channel performed in a 100 kHz bandwidth per the PSD procedure.

### **6.5.2. Test Procedure Used**

ANSI C63.10-2013 - Section 11.11.2 & 11.11.3.

### **6.5.3. Test Setting**

#### **Reference level measurement**

1. Set instrument center frequency to DTS channel center frequency
2. Set the span to  $\geq 1.5$  times the DTS bandwidth
3. Set the RBW = 100 kHz
4. Set the VBW  $\geq 3 \times$  RBW
5. Detector = peak
6. Sweep time = auto couple
7. Trace mode = max hold
8. Allow trace to fully stabilize

#### **Emission level measurement**

1. Set the center frequency and span to encompass frequency range to be measured
2. RBW = 100KHz
3. VBW = 300KHz
4. Detector = Peak
5. Trace mode = max hold
6. Sweep time = auto couple
7. The trace was allowed to stabilize

### 6.5.4. Test Setup

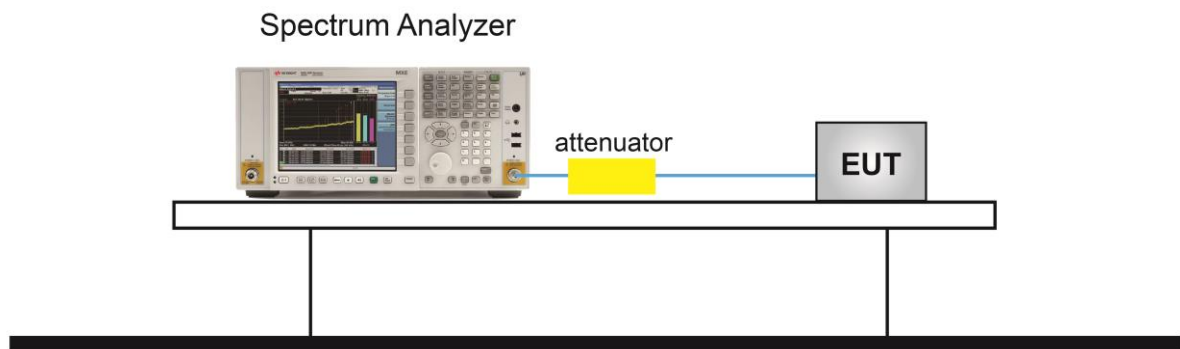

6.5.5. Test Result

Test Site	WZ-TR3	Test Engineer	Yuri Li
Test Date	2021/06/22		

Test Mode	Data Rate / Mbps	Channel No.	Frequency (MHz)	Limit (dBc)	Result
BLE	1	00	2402	20	Pass
BLE	1	19	2440	20	Pass
BLE	1	39	2480	20	Pass

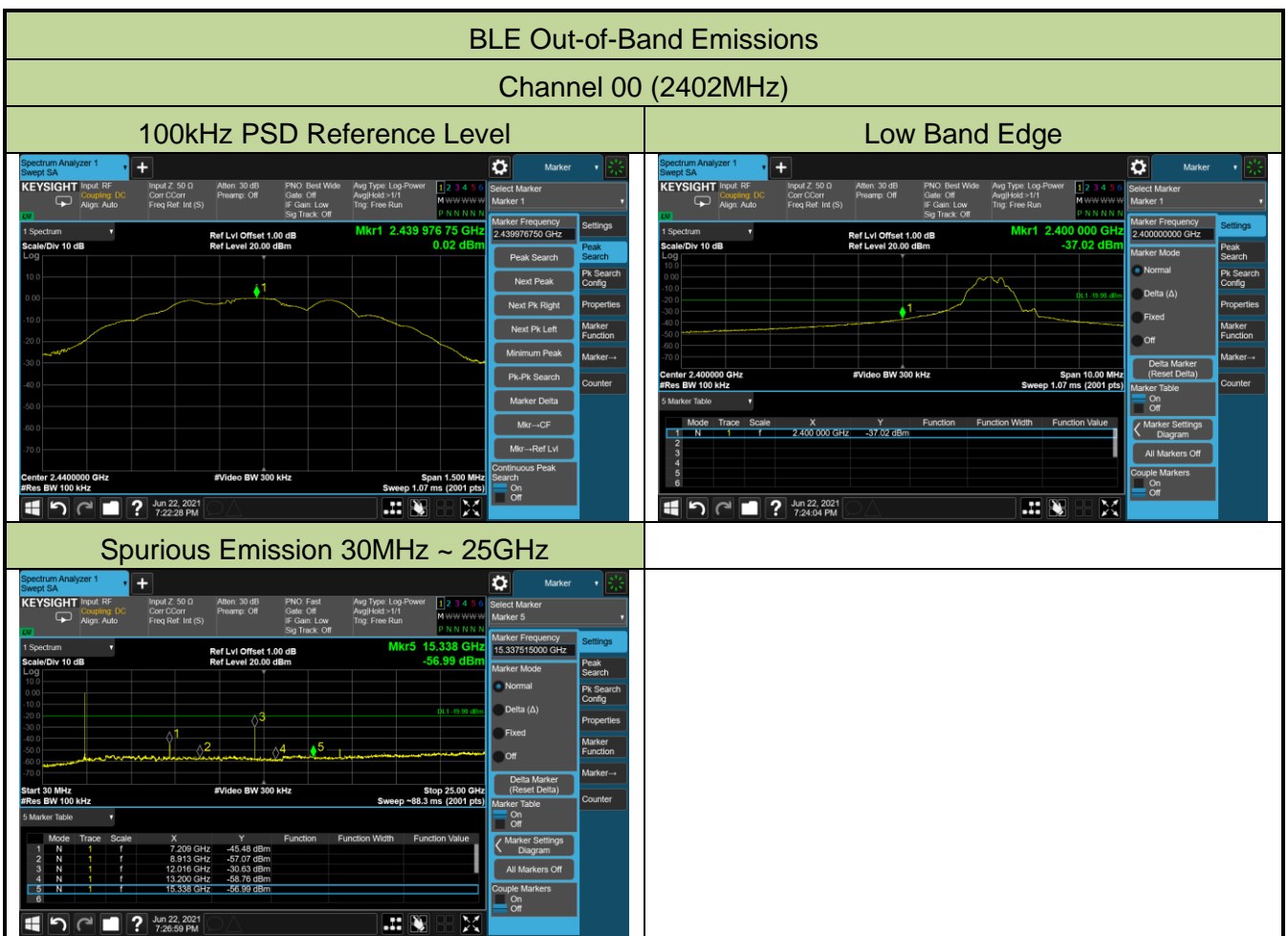

## Channel 19 (2440MHz)

## 100kHz PSD Reference Level

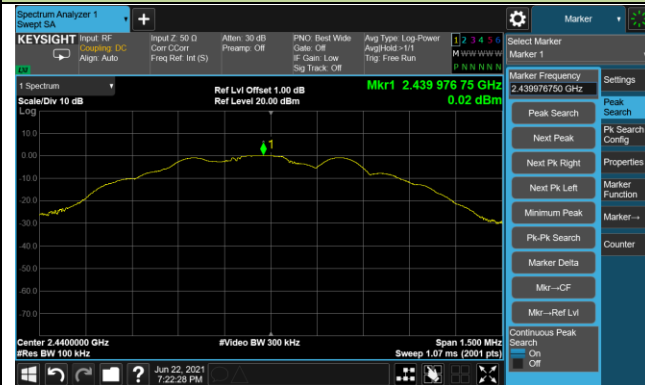

## Spurious Emission 30MHz ~ 25GHz

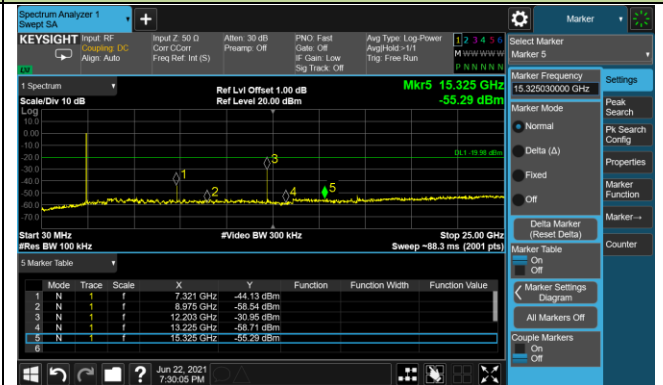

## Channel 39 (2480MHz)

## 100kHz PSD Reference Level

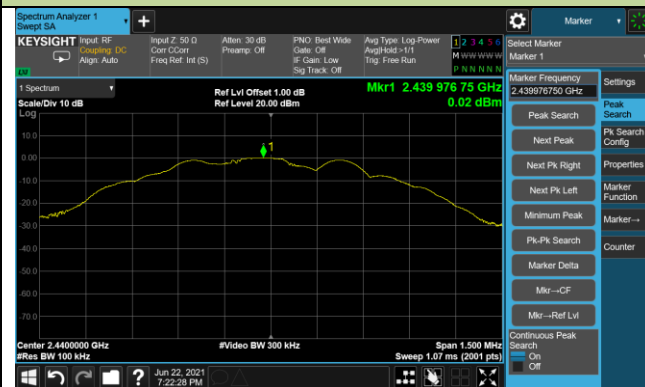

## High Band Edge



## Spurious Emission 30MHz ~ 25GHz

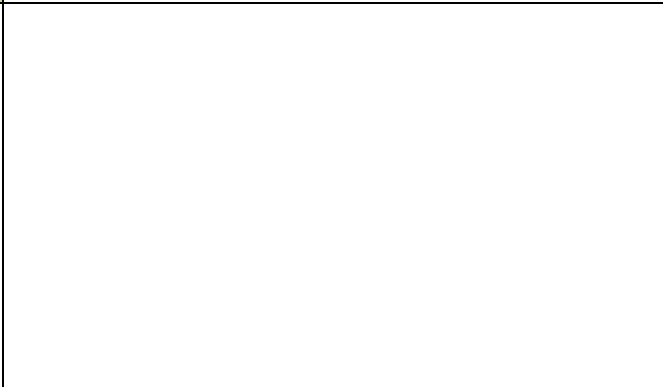
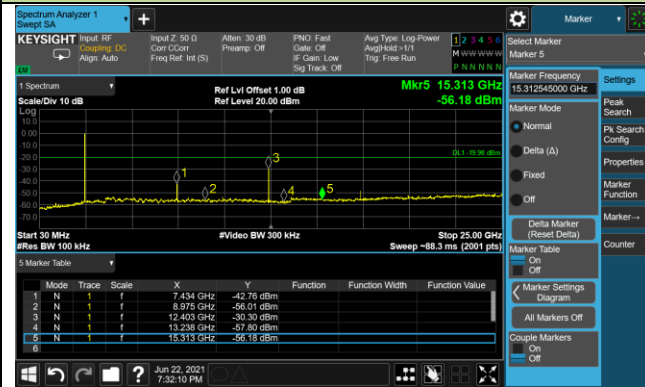

## 6.6. Radiated Spurious Emission Measurement

### 6.6.1. Test Limit

All out of band emissions appearing in a restricted band as specified in Section 15.205 of the Title 47CFR must not exceed the limits shown in Table per Section 15.209.

FCC Part 15 Subpart C Paragraph 15.209		
Frequency [MHz]	Field Strength [uV/m]	Measured Distance [Meters]
0.009 - 0.490	2400/F (kHz)	300
0.490 - 1.705	24000/F (kHz)	30
1.705 - 30	30	30
30 - 88	100	3
88 - 216	150	3
216 - 960	200	3
Above 960	500	3

### 6.6.2. Test Procedure Used

ANSI C63.10 Section 6.3 (General Requirements)

ANSI C63.10 Section 6.4 (Standard test method below 30MHz)

ANSI C63.10 Section 6.5 (Standard test method above 30MHz to 1GHz)

ANSI C63.10 Section 6.6 (Standard test method above 1GHz)

### 6.6.3. Test Setting

**Table 1 - RBW as a function of frequency**

Frequency	RBW
9 ~ 150 kHz	200 ~ 300 Hz
0.15 ~ 30 MHz	9 ~ 10 kHz
30 ~ 1000 MHz	100 ~ 120 kHz
> 1000 MHz	1 MHz



**Quasi-Peak Measurements below 1GHz**

1. Analyzer center frequency was set to the frequency of the radiated spurious emission of interest
2. Span was set greater than 1MHz
3. RBW = as specified in Table 1
4. Detector = CISPR quasi-peak
5. Sweep time = auto couple
6. Trace was allowed to stabilize

**Peak Measurements above 1GHz**

1. Analyzer center frequency was set to the frequency of the radiated spurious emission of interest
2. RBW = 1MHz
3. VBW = 3MHz
4. Detector = peak
5. Sweep time = auto couple
6. Trace mode = max hold
7. Trace was allowed to stabilize

**Average Measurements above 1GHz (Method VB)**

1. Analyzer center frequency was set to the frequency of the radiated spurious emission of interest
2. RBW = 1MHz
3. VBW; If the EUT is configured to transmit with duty cycle  $\geq 98\%$ , set VBW = 10 Hz.  
If the EUT duty cycle is  $< 98\%$ , set VBW  $\geq 1/T$ . T is the minimum transmission duration.
4. Detector = Peak
5. Sweep time = auto
6. Trace mode = max hold
7. Trace was allowed to stabilize

### 6.6.4. Test Setup

#### Below 1GHz Test Setup:

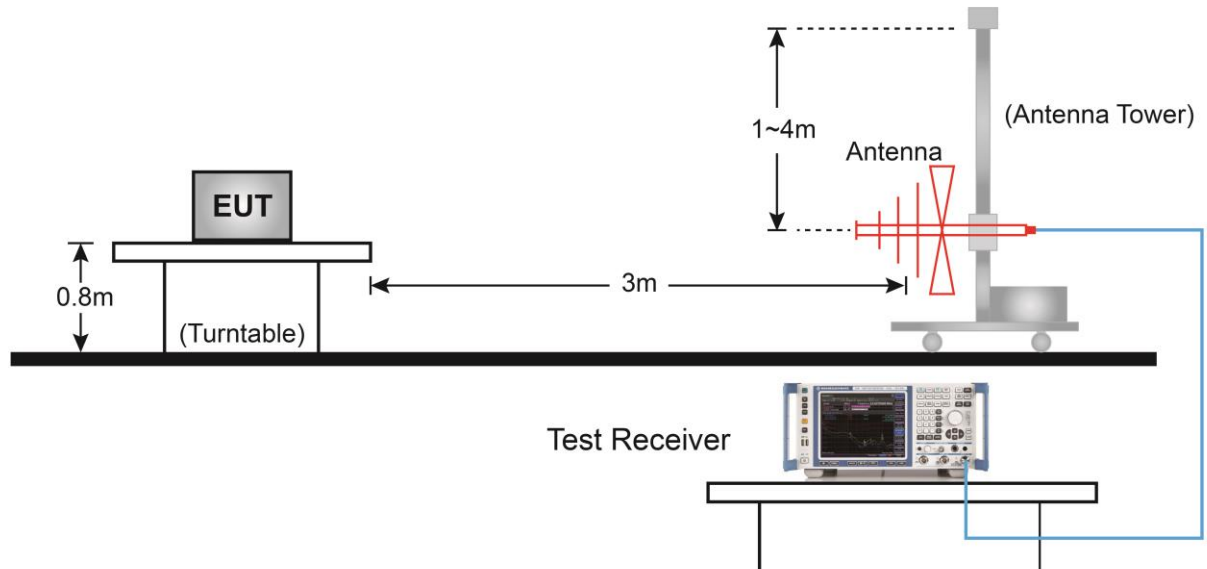

#### Above 1GHz Test Setup:

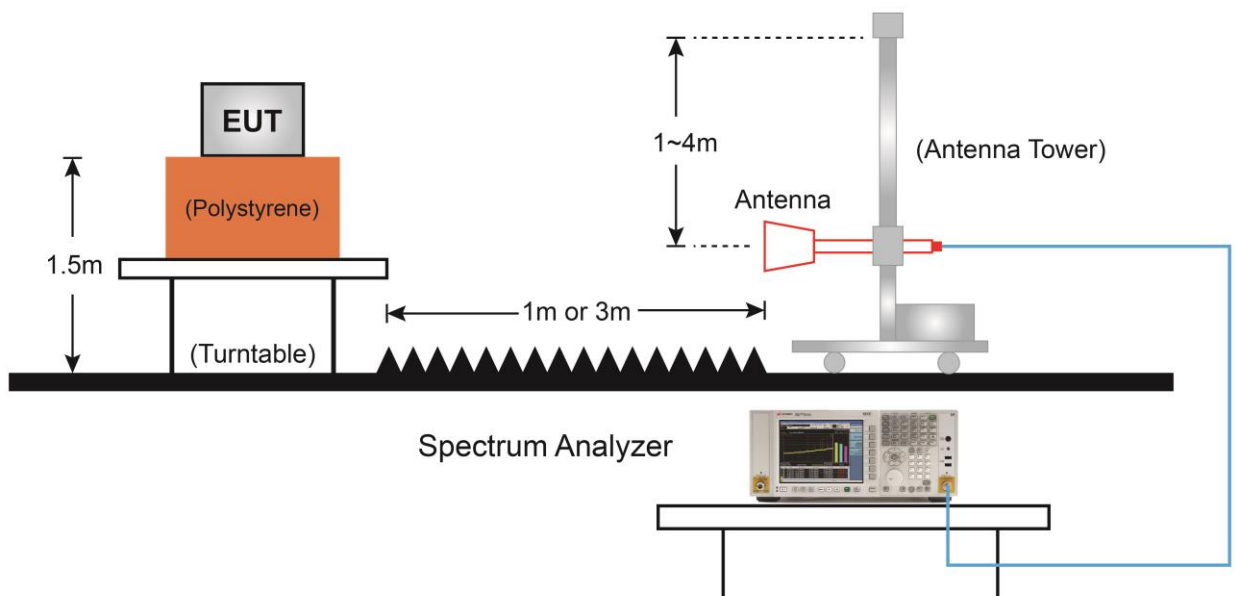

### 6.6.5. Test Result

Test Site	WZ-AC2	Test Engineer	Tommy Tang
Test Date	2021/06/23	Test Channel	00
Test Mode	BLE		
Note	1. Average measurement was not performed if peak level lower than average limit. 2. Other frequency was 20dB below limit line within 1-18GHz, there is not show in the report.		

Mark	Frequency (MHz)	Reading Level (dB $\mu$ V)	Factor (dB)	Measure Level (dB $\mu$ V/m)	Limit (dB $\mu$ V/m)	Margin (dB)	Detector	Polarization
	8199.5	37.2	9.1	46.3	74.0	-27.7	Peak	Horizontal
	9109.0	38.0	11.2	49.2	74.0	-24.8	Peak	Horizontal
	12007.5	44.0	12.5	56.5	74.0	-17.5	Peak	Horizontal
	12007.5	25.0	12.5	37.5	54.0	-16.6	Average	Horizontal
	8131.5	38.2	9.2	47.4	74.0	-26.6	Peak	Vertical
	9075.0	37.9	10.9	48.8	74.0	-25.2	Peak	Vertical
	12007.5	50.4	12.5	62.9	74.0	-11.1	Peak	Vertical
	12007.5	31.4	12.5	43.9	54.0	-10.2	Average	Vertical

Note: Measure Level (dB $\mu$ V/m) = Reading Level (dB $\mu$ V) + Factor (dB)

Factor (dB) = Cable Loss (dB) + Antenna Factor (dB/m) - Pre\_Amplifier Gain (dB)

Test Site	WZ-AC2	Test Engineer	Tommy Tang
Test Date	2021/06/23	Test Channel	19
Test Mode	BLE		
Note	1. Average measurement was not performed if peak level lower than average limit. 2. Other frequency was 20dB below limit line within 1-18GHz, there is not show in the report.		

Mark	Frequency (MHz)	Reading Level (dB $\mu$ V)	Factor (dB)	Measure Level (dB $\mu$ V/m)	Limit (dB $\mu$ V/m)	Margin (dB)	Detector	Polarization
	7315.5	43.0	8.6	51.6	74.0	-22.4	Peak	Horizontal
	8157.0	35.8	9.1	44.9	74.0	-29.1	Peak	Horizontal
	12194.5	45.1	12.8	57.9	74.0	-16.1	Peak	Horizontal
	12194.5	26.1	12.8	38.9	54.0	-15.2	Average	Horizontal
	7324.0	49.0	8.6	57.6	74.0	-16.4	Peak	Vertical
	7324.0	30.0	8.6	38.6	54.0	-15.5	Average	Vertical
	8301.5	37.2	8.9	46.1	74.0	-27.9	Peak	Vertical
	12203.0	48.3	12.7	61.0	74.0	-13.0	Peak	Vertical
	12203.0	29.3	12.7	42.0	54.0	-12.1	Average	Vertical

Note: Measure Level (dB $\mu$ V/m) = Reading Level (dB $\mu$ V) + Factor (dB)

Factor (dB) = Cable Loss (dB) + Antenna Factor (dB/m) - Pre\_Amplifier Gain (dB)

Test Site	WZ-AC2	Test Engineer	Tommy Tang
Test Date	2021/06/23	Test Channel	39
Test Mode	BLE		
Note	1. Average measurement was not performed if peak level lower than average limit. 2. Other frequency was 20dB below limit line within 1-18GHz, there is not show in the report.		

Mark	Frequency (MHz)	Reading Level (dBμV)	Factor (dB)	Measure Level (dBμV/m)	Limit (dBμV/m)	Margin (dB)	Detector	Polarization
	7443.0	46.6	8.5	55.1	74.0	-18.9	Peak	Horizontal
	7443.0	27.6	8.5	36.1	54.0	-18.0	Average	Horizontal
	8429.0	35.8	9.2	45.0	74.0	-29.0	Peak	Horizontal
	12398.5	45.5	12.2	57.7	74.0	-16.3	Peak	Horizontal
	12398.5	26.5	12.2	38.7	54.0	-15.4	Average	Horizontal
	7443.0	50.2	8.5	58.7	74.0	-15.3	Peak	Vertical
	7443.0	31.2	8.5	39.7	54.0	-14.4	Average	Horizontal
	8242.0	37.1	8.8	45.9	74.0	-28.1	Peak	Vertical
	12398.5	46.7	12.2	58.9	74.0	-15.1	Peak	Vertical
	12398.5	27.7	12.2	39.9	54.0	-14.2	Average	Horizontal

Note: Measure Level (dBμV/m) = Reading Level (dBμV) + Factor (dB)

Factor (dB) = Cable Loss (dB) + Antenna Factor (dB/m) - Pre\_Amplifier Gain (dB)

**The Worst Case of Radiated Emission below 1GHz:**

Site: WZ-AC1	Time: 2021/06/23 - 22:43
Limit: FCC_Part15.209_RE(3m)	Engineer: Tommy Tang
Probe: WZ-AC1_VULB 9168 _30-1000MHz	Polarity: Horizontal
EUT: Ninebot Telematics Box	Power: By USB
Test Mode: Transmit by BLE at Channel 2402MHz	

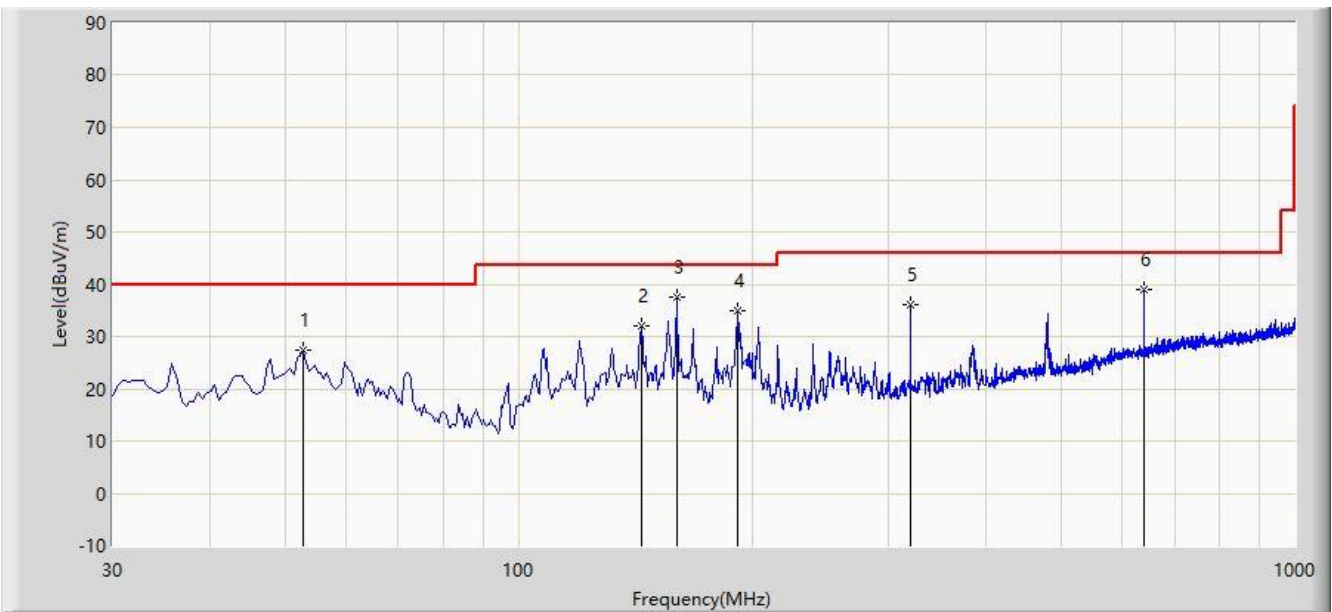

No	Flag	Mark	Frequency (MHz)	Measure Level (dB $\mu$ V/m)	Reading Level (dB $\mu$ V)	Margin (dB)	Limit (dB $\mu$ V/m)	Factor (dB)	Type
1			52.795	27.309	9.347	-12.691	40.000	17.962	PK
2			143.975	32.120	14.379	-11.380	43.500	17.741	PK
3		*	159.980	37.487	19.514	-6.013	43.500	17.973	PK
4			191.990	35.054	19.829	-8.446	43.500	15.225	PK
5			320.030	36.098	17.146	-9.902	46.000	18.952	PK
6			640.130	39.113	12.974	-6.887	46.000	26.139	PK

Note 1: Measure Level (dB $\mu$ V/m) = Reading Level (dB $\mu$ V) + Factor (dB)

Factor (dB) = Cable Loss (dB) + Antenna Factor (dB/m)

Note 2: The amplitude of radiated emissions (frequency range from 9kHz ~ 30MHz, 18GHz to 25GHz) is that proximity to ambient noise, which also are attenuated more than 20 dB below the permissible value. Therefore, the data is not presented in the report.

Site: WZ-AC1	Time: 2021/06/23 - 23:15
Limit: FCC_Part15.209_RE(3m)	Engineer: Tommy Tang
Probe: WZ-AC1_VULB 9168 _30-1000MHz	Polarity: Vertical
EUT: Ninebot Telematics Box	Power: By USB
Test Mode: Transmit by BLE at Channel 2402MHz	

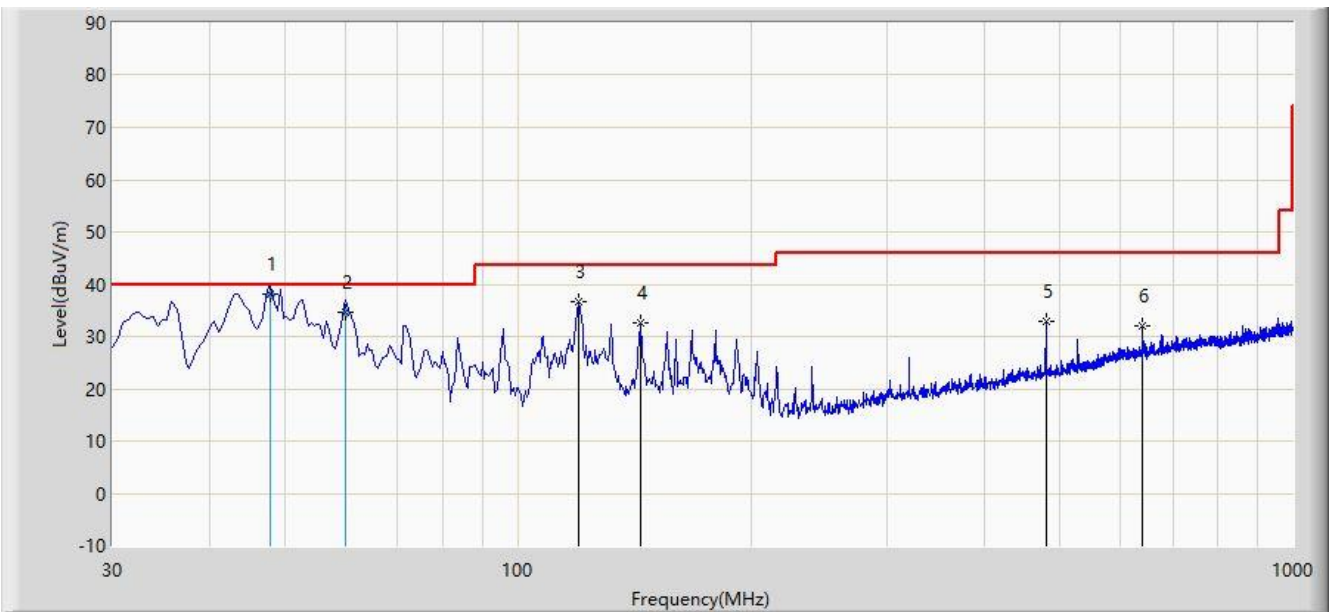

No	Flag	Mark	Frequency (MHz)	Measure Level (dBuV/m)	Reading Level (dBuV)	Margin (dB)	Limit (dBuV/m)	Factor (dB)	Type
1		*	47.945	37.991	20.100	-2.009	40.000	17.892	QP
2			60.070	34.575	17.200	-5.425	40.000	17.375	QP
3			119.725	36.589	20.876	-6.911	43.500	15.714	PK
4			143.975	32.491	14.750	-11.009	43.500	17.741	PK
5			480.080	32.864	10.043	-13.136	46.000	22.821	PK
6			640.130	32.118	5.979	-13.882	46.000	26.139	PK

Note 1: Measure Level (dBuV/m) = Reading Level (dBuV) + Factor (dB)

Factor (dB) = Cable Loss (dB) + Antenna Factor (dB/m)

Note 2: The amplitude of radiated emissions (frequency range from 9kHz ~ 30MHz, 18GHz to 25GHz) is that proximity to ambient noise, which also are attenuated more than 20 dB below the permissible value. Therefore, the data is not presented in the report.

## 6.7. Radiated Restricted Band Edge Measurement

### 6.7.1. Test Limit

#### **For 15.205 requirement:**

Radiated emissions which fall in the restricted bands, as defined in Section 15.205(a) of FCC part 15, must also comply with the radiated emission limits specified in Section 15.209(a).

Frequency (MHz)	Frequency (MHz)	Frequency (MHz)	Frequency (GHz)
0.090 - 0.110	16.42 - 16.423	399.9 - 410	4.5 - 5.15
<sup>1</sup> 0.495 - 0.505	16.69475 - 16.69525	608 - 614	5.35 - 5.46
2.1735 - 2.1905	16.80425 - 16.80475	960 - 1240	7.25 - 7.75
4.125 - 4.128	25.5 - 25.67	1300 - 1427	8.025 - 8.5
4.17725 - 4.17775	37.5 - 38.25	1435 - 1626.5	9.0 - 9.2
4.20725 - 4.20775	73 - 74.6	1645.5 - 1646.5	9.3 - 9.5
6.215 - 6.218	74.8 - 75.2	1660 - 1710	10.6 - 12.7
6.26775 - 6.26825	108 - 121.94	1718.8 - 1722.2	13.25 - 13.4
6.31175 - 6.31225	123 - 138	2200 - 2300	14.47 - 14.5
8.291 - 8.294	149.9 - 150.05	2310 - 2390	15.35 - 16.2
8.362 - 8.366	156.52475 - 156.52525	2483.5 - 2500	17.7 - 21.4
8.37625 - 8.38675	156.7 - 156.9	2690 - 2900	22.01 - 23.12
8.41425 - 8.41475	162.0125 - 167.17	3260 - 3267	23.6 - 24.0
12.29 - 12.293	167.72 - 173.2	3332 - 3339	31.2 - 31.8
12.51975 - 12.52025	240 - 285	3345.8 - 3358	36.43 - 36.5
12.57675 - 12.57725	322 - 335.4	3600 - 4400	( <sup>2</sup> )
13.36 - 13.41	--	--	--



All out of band emissions appearing in a restricted band as specified in Section 15.205 of the Title 47CFR must not exceed the limits shown in Table per Section 15.209.

FCC Part 15 Subpart C Paragraph 15.209 Limits		
Frequency [MHz]	Field Strength [uV/m]	Measured Distance [Meters]
0.009 - 0.490	2400/F (kHz)	300
0.490 - 1.705	24000/F (kHz)	30
1.705 - 30	30	30
30 - 88	100	3
88 - 216	150	3
216 - 960	200	3
Above 960	500	3

### 6.7.2. Test Procedure Used

ANSI C63.10 Section 6.3 (General Requirements)

ANSI C63.10 Section 6.6 (Standard test method above 1GHz)

### 6.7.3. Test Setting

#### Peak Field Strength Measurements

1. Analyzer center frequency was set to the frequency of the radiated spurious emission of interest
2. RBW = 1MHz
3. VBW = 3MHz
4. Detector = peak
5. Sweep time = auto couple
6. Trace mode = max hold
7. Trace was allowed to stabilize

### Average Measurements above 1GHz (Method VB)

1. Analyzer center frequency was set to the frequency of the radiated spurious emission of interest
2. RBW = 1MHz
3. VBW; If the EUT is configured to transmit with duty cycle  $\geq 98\%$ , set VBW = 10 Hz.  
If the EUT duty cycle is  $< 98\%$ , set VBW  $\geq 1/T$ . T is the minimum transmission duration.

4. Detector = Peak
5. Sweep time = auto
6. Trace mode = max hold
7. Trace was allowed to stabilize

#### 6.7.4. Test Setup

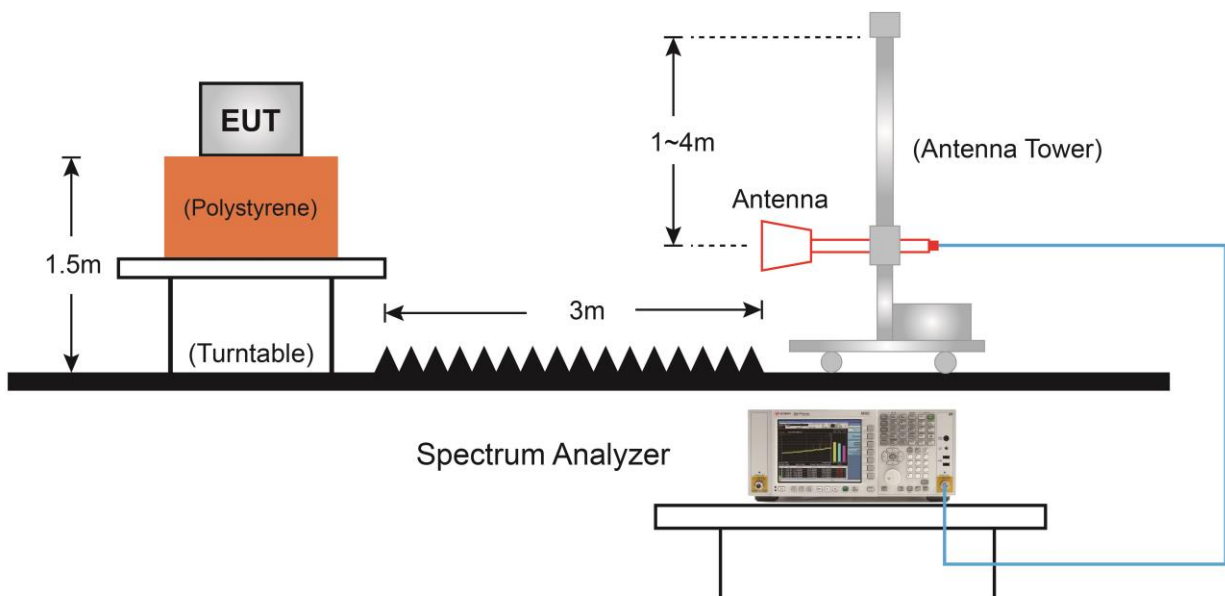

### 6.7.5. Test Result

Site: WZ-AC1	Time: 2021/06/24 - 00:06
Limit: FCC_Part15.209_RE(3m)	Engineer: Tommy Tang
Probe: WZ-AC1_BBHA9120D_1-18GHz	Polarity: Horizontal
EUT: Ninebot Telematics Box	Power: By Battery
Test Mode: Transmit by BLE at Channel 2402MHz	

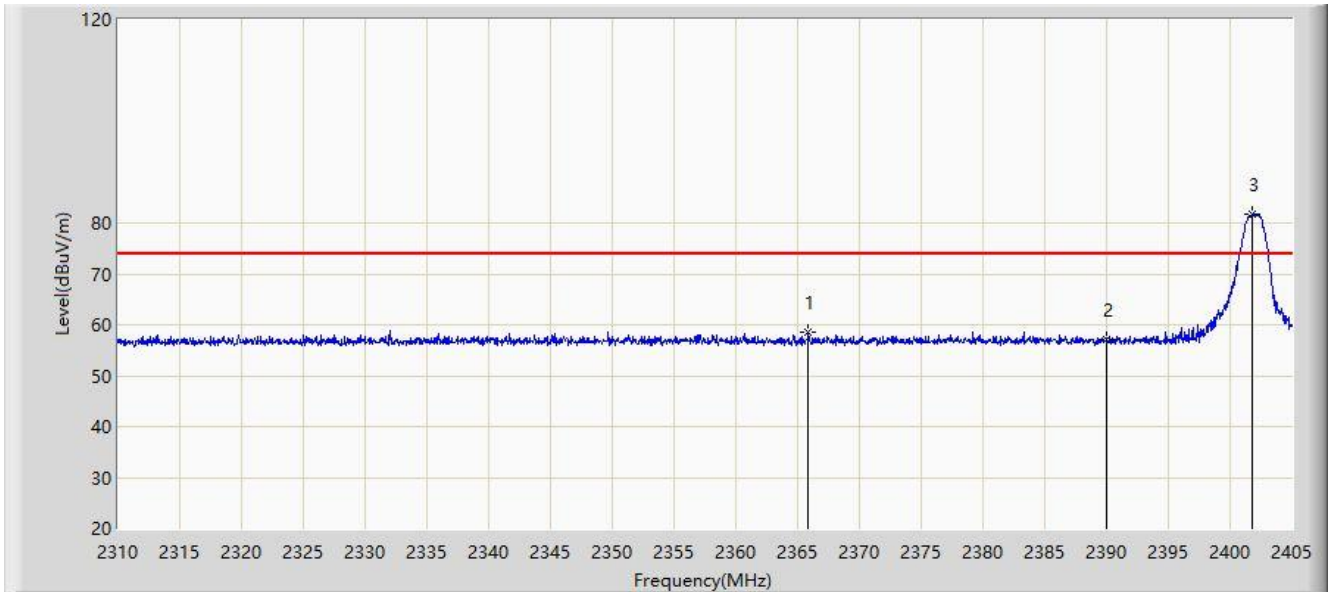

No	Flag	Mark	Frequency (MHz)	Measure Level (dBuV/m)	Reading Level (dBuV)	Margin (dB)	Limit (dBuV/m)	Factor (dB)	Type
1			2365.860	58.423	27.364	-15.577	74.000	31.059	PK
2			2390.000	57.086	26.053	-16.914	74.000	31.034	PK
3		*	2401.770	81.682	50.673	N/A	N/A	31.009	PK

Note: Measure Level (dB $\mu$ V/m) = Reading Level (dB $\mu$ V) + Factor (dB)

Factor (dB) = Cable Loss (dB) + Antenna Factor (dB/m)

Site: WZ-AC1	Time: 2021/06/24 - 00:08
Limit: FCC_Part15.209_RE(3m)	Engineer: Tommy Tang
Probe: WZ-AC1_BBHA9120D_1-18GHz	Polarity: Horizontal
EUT: Ninebot Telematics Box	Power: By Battery
Test Mode: Transmit by BLE at Channel 2402MHz	

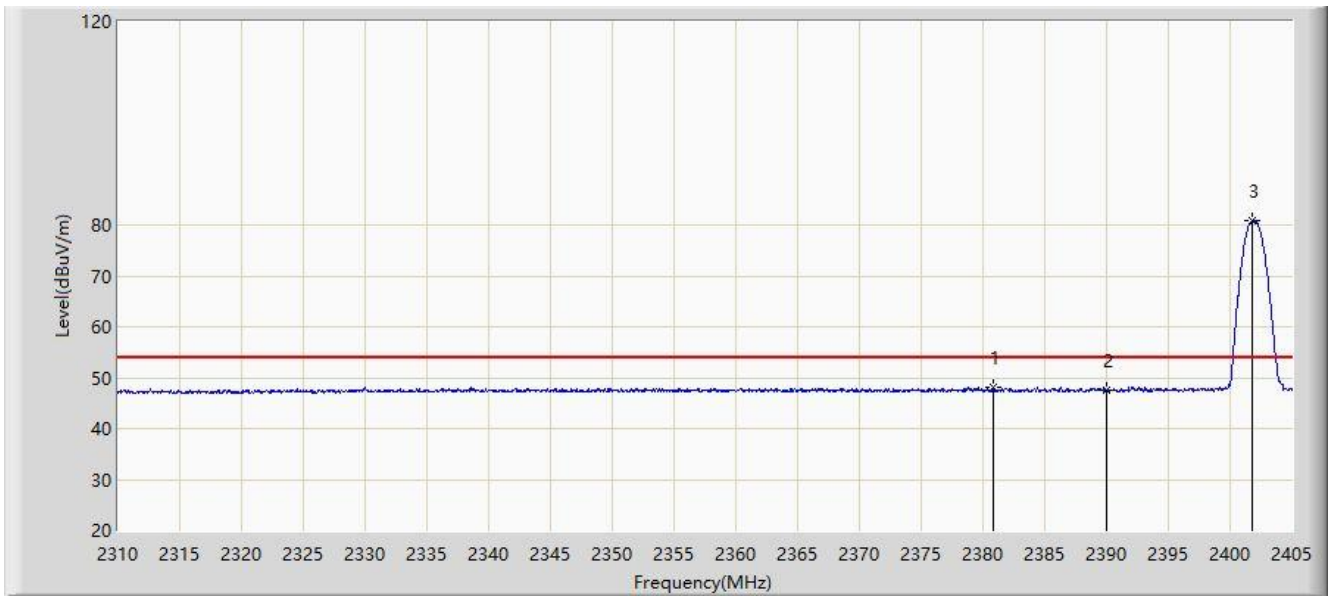

No	Flag	Mark	Frequency (MHz)	Measure Level (dBuV/m)	Reading Level (dBuV)	Margin (dB)	Limit (dBuV/m)	Factor (dB)	Type
1			2380.870	48.114	17.073	-5.886	54.000	31.042	AV
2			2390.000	47.611	16.578	-6.389	54.000	31.034	AV
3		*	2401.770	80.755	49.746	N/A	N/A	31.009	AV

Note: Measure Level (dB $\mu$ V/m) = Reading Level (dB $\mu$ V) + Factor (dB)

Factor (dB) = Cable Loss (dB) + Antenna Factor (dB/m)

Site: WZ-AC1	Time: 2021/06/24 - 00:10
Limit: FCC_Part15.209_RE(3m)	Engineer: Tommy Tang
Probe: WZ-AC1_BBHA9120D_1-18GHz	Polarity: Vertical
EUT: Ninebot Telematics Box	Power: By Battery
Test Mode: Transmit by BLE at Channel 2402MHz	

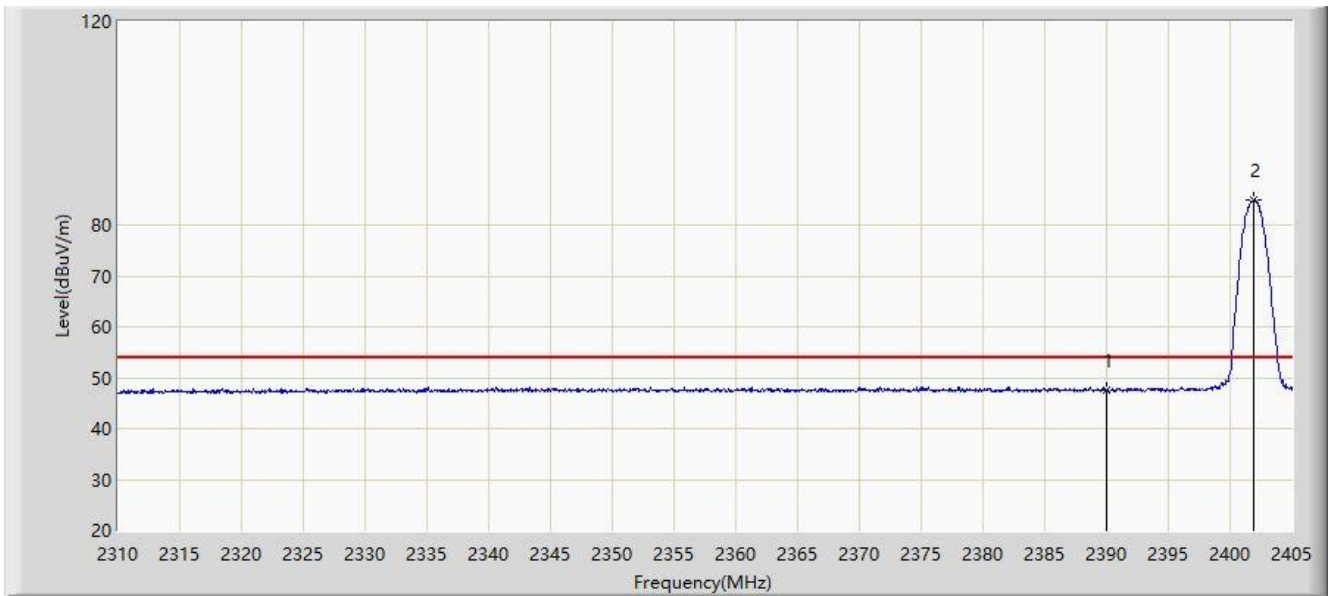

No	Flag	Mark	Frequency (MHz)	Measure Level (dBuV/m)	Reading Level (dBuV)	Margin (dB)	Limit (dBuV/m)	Factor (dB)	Type
1			2390.000	47.491	16.458	-6.509	54.000	31.034	AV
2		*	2401.865	84.836	53.827	N/A	N/A	31.009	AV

Note: Measure Level (dBuV/m) = Reading Level (dBuV) + Factor (dB)

Factor (dB) = Cable Loss (dB) + Antenna Factor (dB/m)

Site: WZ-AC1	Time: 2021/06/24 - 00:12
Limit: FCC_Part15.209_RE(3m)	Engineer: Tommy Tang
Probe: WZ-AC1_BBHA9120D_1-18GHz	Polarity: Vertical
EUT: Ninebot Telematics Box	Power: By Battery
Test Mode: Transmit by BLE at Channel 2402MHz	

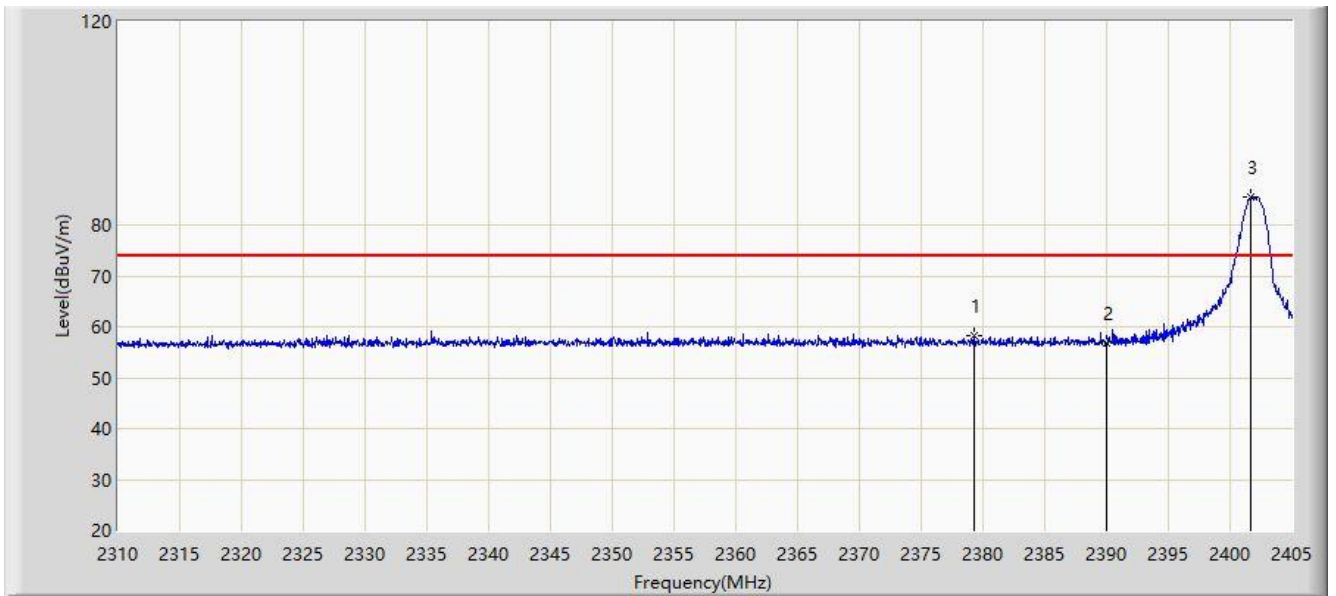

No	Flag	Mark	Frequency (MHz)	Measure Level (dBuV/m)	Reading Level (dBuV)	Margin (dB)	Limit (dBuV/m)	Factor (dB)	Type
1			2379.255	58.363	27.320	-15.637	74.000	31.043	PK
2			2390.000	56.729	25.696	-17.271	74.000	31.034	PK
3		*	2401.722	85.399	54.390	N/A	N/A	31.008	PK

Note: Measure Level (dB $\mu$ V/m) = Reading Level (dB $\mu$ V) + Factor (dB)

Factor (dB) = Cable Loss (dB) + Antenna Factor (dB/m)

Site: WZ-AC1	Time: 2021/06/24 - 00:14
Limit: FCC_Part15.209_RE(3m)	Engineer: Tommy Tang
Probe: WZ-AC1_BBHA9120D_1-18GHz	Polarity: Horizontal
EUT: Ninebot Telematics Box	Power: By Battery
Test Mode: Transmit by BLE at Channel 2480MHz	

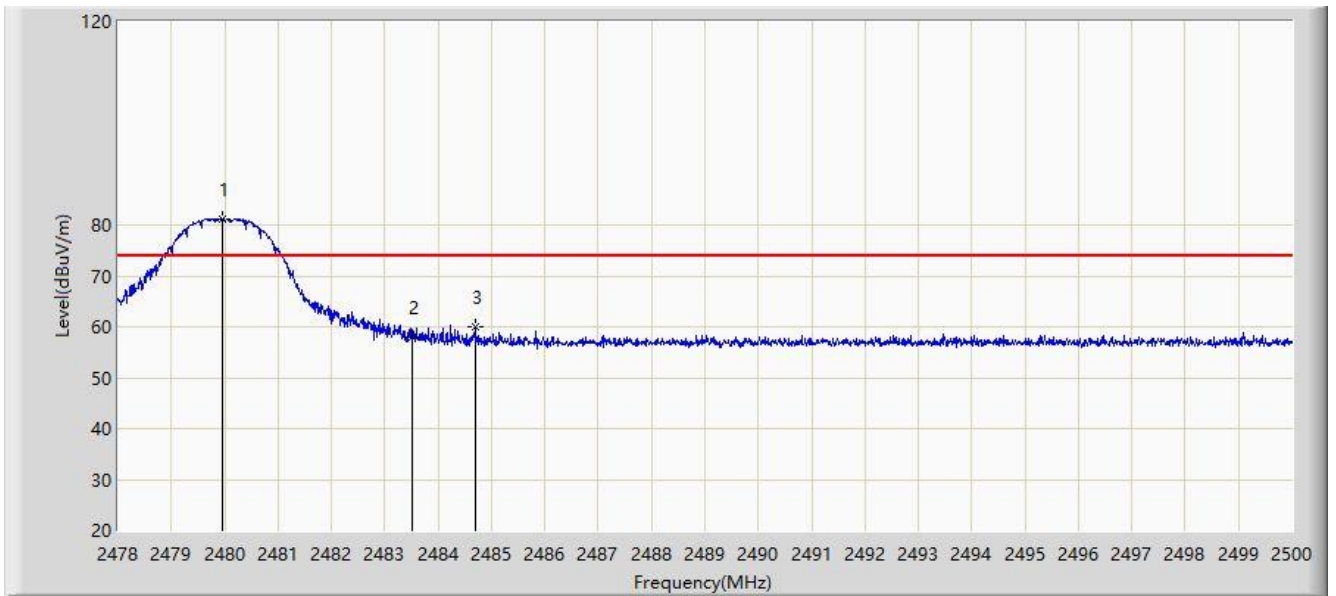

No	Flag	Mark	Frequency (MHz)	Measure Level (dBuV/m)	Reading Level (dBuV)	Margin (dB)	Limit (dBuV/m)	Factor (dB)	Type
1		*	2479.969	81.113	50.236	N/A	N/A	30.876	PK
2			2483.500	58.034	27.146	-15.966	74.000	30.888	PK
3			2484.688	60.044	29.152	-13.956	74.000	30.891	PK

Note: Measure Level (dB $\mu$ V/m) = Reading Level (dB $\mu$ V) + Factor (dB)

Factor (dB) = Cable Loss (dB) + Antenna Factor (dB/m)

Site: WZ-AC1	Time: 2021/06/24 - 00:16
Limit: FCC_Part15.209_RE(3m)	Engineer: Tommy Tang
Probe: WZ-AC1_BBHA9120D_1-18GHz	Polarity: Horizontal
EUT: Ninebot Telematics Box	Power: By Battery
Test Mode: Transmit by BLE at Channel 2480MHz	

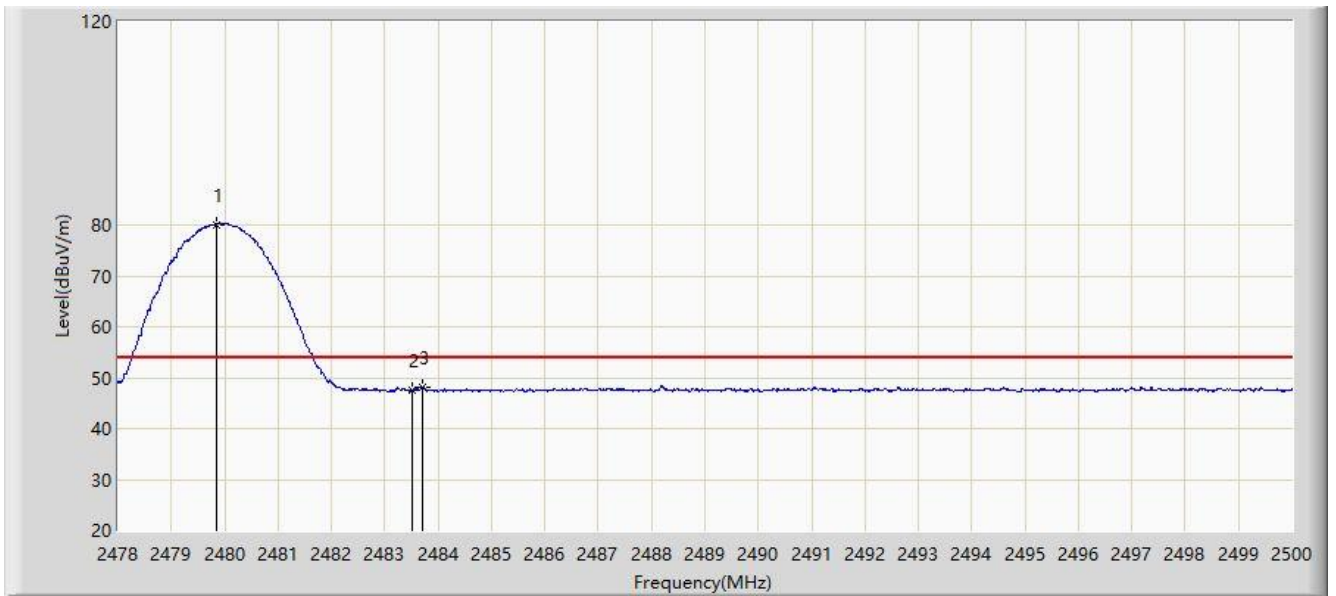

No	Flag	Mark	Frequency (MHz)	Measure Level (dBuV/m)	Reading Level (dBuV)	Margin (dB)	Limit (dBuV/m)	Factor (dB)	Type
1		*	2479.837	80.112	49.236	N/A	N/A	30.876	AV
2			2483.500	47.419	16.531	-6.581	54.000	30.888	AV
3			2483.709	48.231	17.342	-5.769	54.000	30.889	AV

Note: Measure Level (dB $\mu$ V/m) = Reading Level (dB $\mu$ V) + Factor (dB)

Factor (dB) = Cable Loss (dB) + Antenna Factor (dB/m)



Site: WZ-AC1	Time: 2021/06/24 - 00:17
Limit: FCC_Part15.209_RE(3m)	Engineer: Tommy Tang
Probe: WZ-AC1_BBHA9120D_1-18GHz	Polarity: Vertical
EUT: Ninebot Telematics Box	Power: By Battery
Test Mode: Transmit by BLE at Channel 2480MHz	

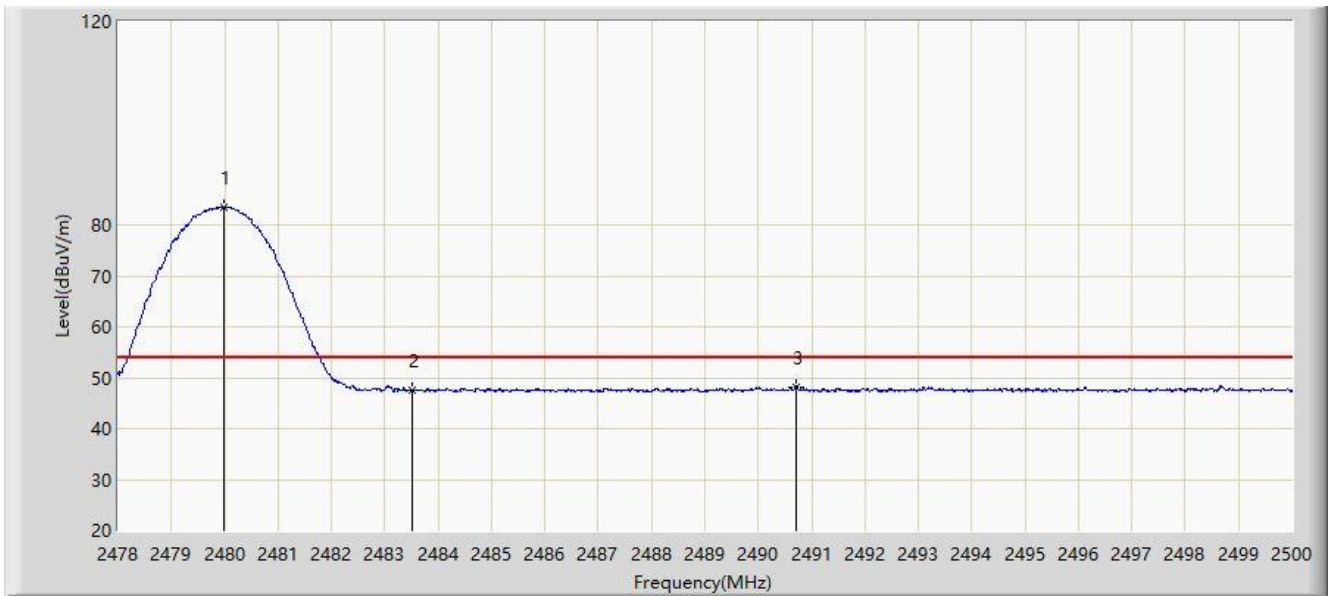

No	Flag	Mark	Frequency (MHz)	Measure Level (dBuV/m)	Reading Level (dBuV)	Margin (dB)	Limit (dBuV/m)	Factor (dB)	Type
1		*	2479.980	83.514	52.637	N/A	N/A	30.876	AV
2			2483.500	47.484	16.596	-6.516	54.000	30.888	AV
3			2490.716	48.181	17.270	-5.819	54.000	30.911	AV

Note: Measure Level (dBuV/m) = Reading Level (dBuV) + Factor (dB)

Factor (dB) = Cable Loss (dB) + Antenna Factor (dB/m)

Site: WZ-AC1	Time: 2021/06/24 - 00:18
Limit: FCC_Part15.209_RE(3m)	Engineer: Tommy Tang
Probe: WZ-AC1_BBHA9120D_1-18GHz	Polarity: Vertical
EUT: Ninebot Telematics Box	Power: By Battery
Test Mode: Transmit by BLE at Channel 2480MHz	

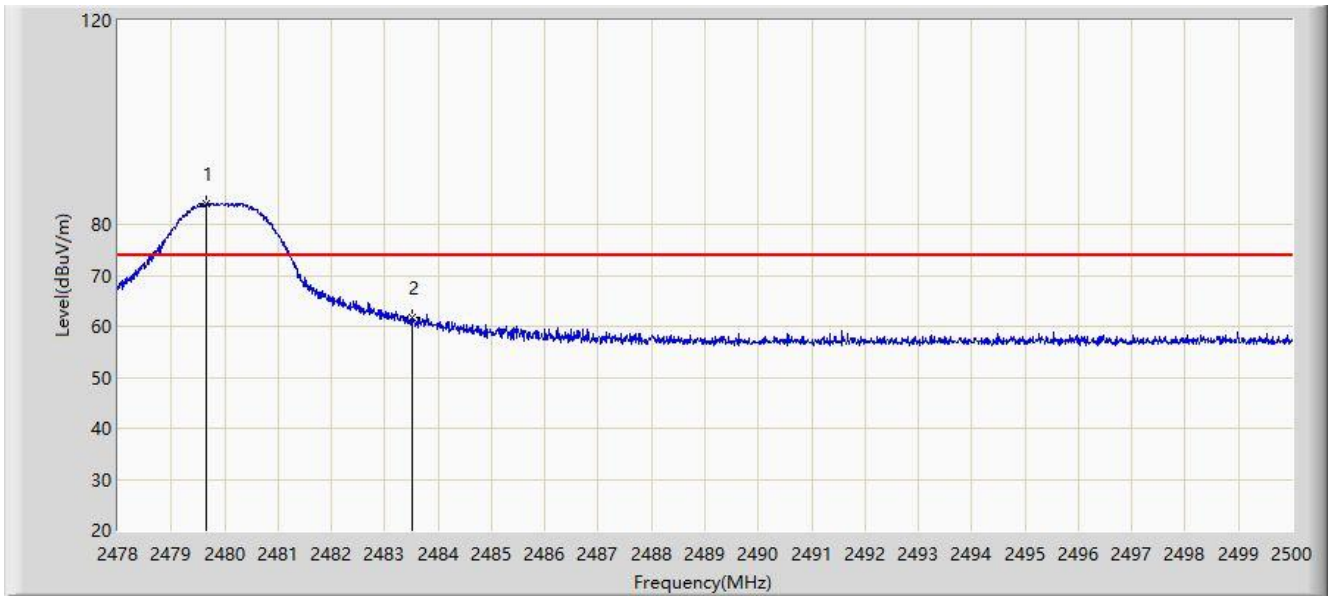

No	Flag	Mark	Frequency (MHz)	Measure Level (dBuV/m)	Reading Level (dBuV)	Margin (dB)	Limit (dBuV/m)	Factor (dB)	Type
1		*	2479.661	84.138	53.262	N/A	N/A	30.876	PK
2			2483.500	61.733	30.845	-12.267	74.000	30.888	PK

Note: Measure Level (dB $\mu$ V/m) = Reading Level (dB $\mu$ V) + Factor (dB)

Factor (dB) = Cable Loss (dB) + Antenna Factor (dB/m)

## 6.8. AC Conducted Emissions Measurement

### 6.8.1. Test Limit

FCC Part 15 Subpart C Paragraph 15.207 Limits		
Frequency (MHz)	QP (dB $\mu$ V)	AV (dB $\mu$ V)
0.15 - 0.50	66 - 56	56 - 46
0.50 - 5.0	56	46
5.0 - 30	60	50

Note 1: The lower limit shall apply at the transition frequencies.

Note 2: The limit decreases linearly with the logarithm of the frequency in the range 0.15MHz to 0.5MHz.

### 6.8.2. Test Setup

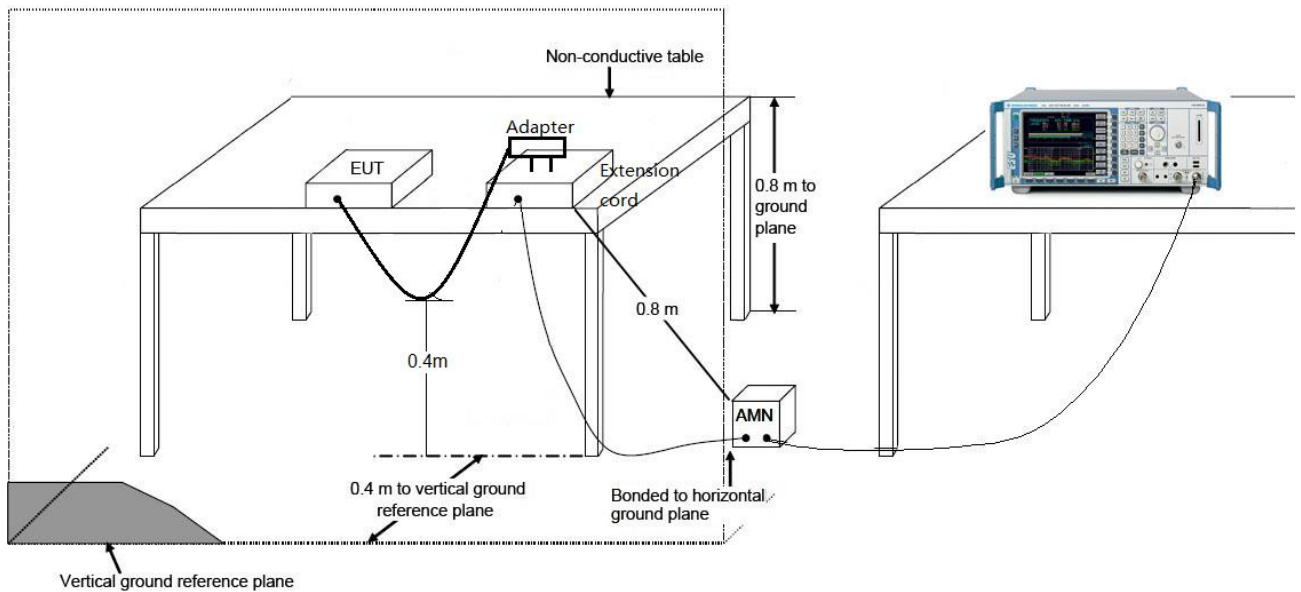

### 6.8.3. Test Result

The EUT is powered by battery, so the item is not applicable.

## 7. CONCLUSION

The data collected relate only the item(s) tested and show that the device is in compliance with Part 15C of the FCC rules.

## **Appendix A - Test Setup Photograph**

Refer to "2106RSU025-UT" file.

## **Appendix B - EUT Photograph**

Refer to " 2106RSU025-UE" file.