



FCC/ IC TEST REPORT

According to

CFR47 §15.247/ RSS-247 Issue 2

Applicant : Ninebot (Changzhou) Tech Co., Ltd.
Address : 16F-17F, Block A, Building 3, Changwu Mid Road 18#, Wujin Dist.,
 Changzhou, Jiangsu, China
Manufacturer : Ninebot (Changzhou) Tech Co., Ltd.
Address : 16F-17F, Block A, Building 3, Changwu Mid Road 18#, Wujin Dist.,
 Changzhou, Jiangsu, China
Equipment : Ninebot KickScooter
Model No. : ES1,ES2,ES4
Trade Name : Ninebot by Segway
FCC ID : 2ALS8-NT9527
IC ID : 22636-NT9527
Test Period : Jun.28,2017~ Jun.30, 2017

- The test result refers exclusively to the test presented test model / sample.
- Without written approval of **CerpPASS Technology Corp.** the test report shall not be reproduced except in full.
- The test report must not be used by the clients to claim product certification approval by **NVLAP** or any agency of the Government.

I HEREBY CERTIFY THAT :

The measurements shown in this test report were made in accordance with the procedures given in **ANSI C63.10 – 2013&RSS-247,Issue 2&RSS-Gen&FCC Part15.247**and the energy emitted by this equipment was **passed**.

Prepared By:

Kerry Zhou

Approved by:

Miro Chueh (EMC/RF Manager)

Laboratory Accreditation:

CerpPASS Technology Corporation Test Laboratory



NVLAP LAB Code:	200954-0
TAF LAB Code:	1439



CerpPASS Technology (SuZhou) Co., Ltd.

NVLAP LAB Code:	200814-0
CNAS LAB Code:	L5515



Contents

1. Report of Measurements and Examinations	5
2. General Info	6
2.1 Description of EUT	6
2.2 Description of wireless module	7
2.3 Description of Antenna	7
2.4 Carrier Frequency of Channels	8
2.5 The Worst Case Configuration	8
2.6 EUT Exercise Software	8
2.7 Duty cycle.....	9
2.8 Support equipment	10
3. General Information of Test Site	11
3.1 Information of Test Site	11
3.2 Measuring Equipment	11
3.3 Measurement Uncertainty	12
4. AC Conducted Emission Measurement	14
4.1 Test Limit	14
4.2 Test Standard	14
4.3 Test Procedures	14
4.4 Test Setup Layout	15
4.5 Test Result	16
5. Radiated Emission Measurement	18
5.1 Test Limit	18
5.2 Test Standard	18
5.3 Test Procedures	19
5.4 Test Setup Layout	20
5.5 Test Result	22
6. 6dB Bandwidth Measurement	34
6.1 Test Limit	34
6.2 Test Standard	34
6.3 Test Procedures	34
6.4 Test Setup Layout	34
6.5 Test Result	35
7. Output Power Measurement	36
7.1 Test Limit	36
7.2 Test Standard	36
7.3 Test Procedures	36
7.4 Test Setup Layout	36
7.5 Test Result	37
8. Power Spectral Density Measurement	38
8.1 Test Limit	38
8.2 Test Standard	38
8.3 Test Procedures	38
8.4 Test Setup Layout	38



8.5 Test Result 39

9. Conducted Band Edge and Out-of-Band Emissions Measurement 40

9.1 Test Limit 40

9.2 Test Standard 40

9.3 Test Procedures 41

9.4 Test Setup Layout 41

9.5 Test Result 42

10.Radiated Emission Band Edge Measurement 45

10.1 Test Limit 45

10.2 Test Standard 45

10.3 Test Procedure 45

10.4 Test Setup Layout 46

10.5 Test Result 47



History of this Test Report

Report No.	Version	Issue Date	Description
SEFB1706203	Rev 01	Jul.12, 2017	Original.



1. Report of Measurements and Examinations

Performed Test Item	Normative References	Test Performed	Deviation	Result
Conducted Emission	FCC CFR Title 47 Part 15 Subpart C: 2016 Section 15.207	Yes	N/A	Pass
Radiated Emission	FCC CFR Title 47 Part 15 Subpart C: 2016 Section 15.209 RSS-Gen Issue 4 November 2014 Section 6.13	Yes	No	Pass
RF Antenna Conducted Spurious	FCC CFR Title 47 Part 15 Subpart C: 2016 Section 15.247(d) RSS-247 Issue 2 February 2017 Section 5.5	Yes	No	Pass
Radiated Emission Band Edge	FCC CFR Title 47 Part 15 Subpart C: 2016 15.247(d) RSS-247 Issue 2 February 2017 Section 5.5	Yes	No	Pass
Operation Frequency Range of 20dB Bandwidth	FCC CFR Title 47 Part 15 Subpart C: 2016 15.215(c)	Yes	No	Pass
Occupied Bandwidth	FCC CFR Title 47 Part 15 Subpart C: 2016 Section 15.247(a)(2) RSS-247 Issue 2 February 2017 Section 5.2(a)	Yes	No	Pass
Output Power	FCC CFR Title 47 Part 15 Subpart C: 2016 Section 15.247(b)(3) RSS-247 Issue 2 February 2017 Section 5.4(d)	Yes	No	Pass
Power Spectral Density	FCC CFR Title 47 Part 15 Subpart C: 2016 Section 15.247(e) RSS-247 Issue 2 February 2017 Section 5.2(b)	Yes	No	Pass



2. General Info

2.1 Description of EUT

Product name	Ninebot KickScooter	
Model No.	ES1,ES2,ES4	
Power supply	BCTA+71420-1700	
	Input:	100-240V~ 50/60Hz 2.00A Max
	Output:	42V $\overline{\text{---}}$ 1.7A



2.2 Description of wireless module

Module Name	nRF51802
BT Specification	Version 4.1
BT Frequency	2402~2480MHz
BT Channel Number	40
BT Channel Separation	2MHz
BT Type of Modulation	GFSK
BT Data Rate	1Mbps(GFSK)
Channel Control	Auto

Note: For more details, please refer to the EUT User manual.

2.3 Description of Antenna

Antenna	Peak Gain
PCB Antenna	-1.26dBi for 2.40~2.50GHz band



2.4 Carrier Frequency of Channels

Bluetooth Working Frequency of Each Channel: (For V4.0)							
Channel	Frequency	Channel	Frequency	Channel	Frequency	Channel	Frequency
00	2402 MHz	01	2404 MHz	02	2406 MHz	03	2408 MHz
04	2410 MHz	05	2412 MHz	06	2414 MHz	07	2416 MHz
08	2418 MHz	09	2420 MHz	10	2422 MHz	11	2424 MHz
12	2426 MHz	13	2428 MHz	14	2430 MHz	15	2432 MHz
16	2434 MHz	17	2436 MHz	18	2438 MHz	19	2440 MHz
20	2442 MHz	21	2444 MHz	22	2446 MHz	23	2448 MHz
24	2450 MHz	25	2452 MHz	26	2454 MHz	27	2456 MHz
28	2458 MHz	29	2460 MHz	30	2462 MHz	31	2464 MHz
32	2466 MHz	33	2468 MHz	34	2470 MHz	35	2472 MHz
36	2474 MHz	37	2476 MHz	38	2478 MHz	39	2480 MHz

2.5 The Worst Case Configuration

Data rate Configuration:

Modulation Mode	Worst Data Rate
BLE	1Mbps(GFSK)

Note: Power output test was verified over all data rates of each mode, and then choose the maximum power output for final test of each channel shown as the table.

2.6 EUT Exercise Software

1	Turn on the power of equipment.
2	Set the test mode and channel, then press OK to start continue transmit.



2.7 Duty cycle

Test Item	Duty cycle
-----------	------------

Mode	Frequency (MHz)	Measurement (%)
BLE	2402	100

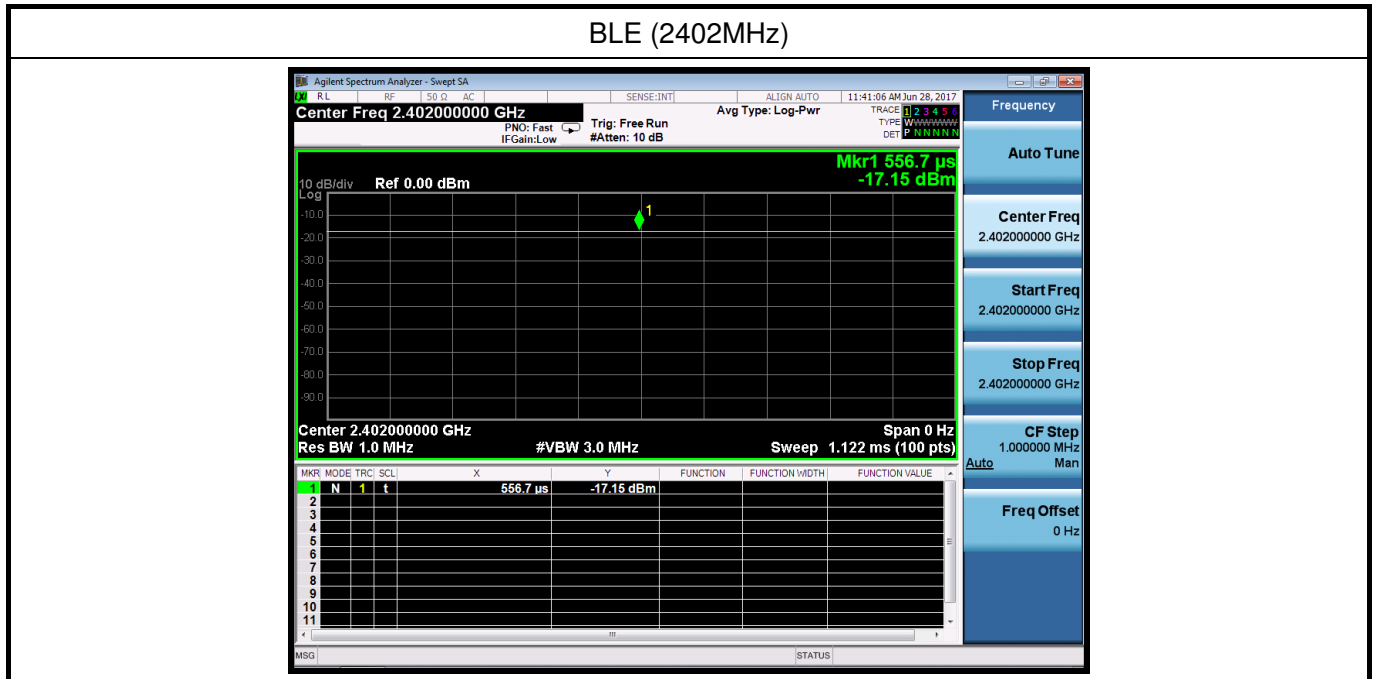



2.8 Support equipment

Product	Manufacturer	Model No.	Serial No.	Power Cord
N/A	N/A	N/A	N/A	N/A

Connection Diagram	
	
Signal Cable Type	Signal cable Description
A N/A	N/A



3. General Information of Test Site

3.1 Information of Test Site

Test Site	CerpPASS Technology(Suzhou) Co., Ltd.
Test Site Location	No.66,Tangzhuang Road, Suzhou Industrial Park, Jiangsu 215006, China
NVLAP LAB Code	200814-0
FCC Registration Number	916572, 331395
IC Registration Number	7290A-1, 7290A-2
VCCI Registration Number	T-1945 for Telecommunication Test C-2919 for Conducted emission test R-2670 for Radiated emission test below 1GHz G-227 for Radiated emission test above 1GHz

3.2 Measuring Equipment

RF Conducted Measuring Equipment-AC104					
Instrument/Ancillary	Manufacturer	Model No.	Serial No.	Calibration Date	Valid Date.
Peak Power Sensor	Boonton	55006	9778	2017.06.08	2018.06.07
Series Power Meter	ANRITSU	ML2495A	1224005	2017.03.27	2018.03.26
Spectrum Analyzer	N9010A	Agilent	MY53400169	2016.11.11	2017.11.11
Spectrum Analyzer	E4407B	Agilent	MY44211883	2016.10.15	2017.10.14
Temperature/Humidity Meter	Zhicheng	ZC1-11	CEP-TH-003	2017.03.31	2018.03.30

AC Conducted Emission Measuring Equipment-SR101					
Instrument/Ancillary	Manufacturer	Model No.	Serial No.	Calibration Date	Valid Date.
EZ-EMC	Fala	Ver CT3A1	N/A	N/A	N/A
EMI Test Receiver	R&S	ESCI	100565	2017.03.26	2018.03.25
Artificial-Mains-Network	R&S	ESH2-Z5	100182	2016.08.31	2017.08.30
Line Impedance Stabilization Network	FCC	FCC-LISN-50-200-2-02	112087	2016.08.31	2017.08.30
Temperature/Humidity Meter	Zhicheng	ZC1-11	CEP-TH-004	2017.03.29	2018.03.28



Radiated Measuring Equipment-AC102					
Instrument/Ancillary	Manufacturer	Model No.	Serial No.	Calibration Date	Valid Date.
Loop Antenna	R&S	HFH2-Z2	100150	2016.08.31	2017.08.30
Bilog Antenna	Sunol Science	JB1	A072414-1	2017.04.16	2018.04.15
Broad-Band Horn Antenna	Schwarzbeck	BBHA9120D	9120D-619	2016.07.16	2017.07.15
Broad-Band Horn Antenna	Schwarzbeck	BBHA9170	9170-348	2017.05.07	2018.05.06
Preamplifier	HP	8447F	3113A05582	2017.03.26	2018.03.25
Preamplifier	EMCI	EMC-051835	980085	2016.09.06	2017.09.05
Preamplifier	COM-POWER	PA-840	711885	2017.03.26	2018.03.25
EMI Test Receiver	R&S	ESCI-3	101183	2016.06.29	2017.06.28
Spectrum Analyzer	N9010A	Agilent	MY53400169	2016.11.11	2017.11.11
Spectrum Analyzer	R&S	FS040	100324	2017.03.26	2018.03.25
Temperature/ Humidity Meter	Zhicheng	ZC1-11	CEP-TH-002	2017.03.31	2018.03.30

3.3 Measurement Uncertainty

ISO/IEC 17025 requires that an estimate of the measurement uncertainties associated with the emissions test results be included in the report. The measurement uncertainties given below are based on a 95% confidence level (based on a coverage factor (k=2)).

RF Conducted Measurement

Test Item	Uncertainty	Limit
Radio Frequency	$\pm 8.7 \times 10^{-7}$	$\pm 1 \times 10^{-5}$
RF output power, conducted	$\pm 0.63\text{dB}$	$\pm 1.5\text{dB}$
Power density, conducted	$\pm 1.21\text{dB}$	$\pm 3\text{dB}$
Unwanted emissions, conducted	30-1000MHz	$\pm 0.51\text{dB}$
	1-25GHz	$\pm 0.67\text{dB}$
All emissions, radiated	30-1000MHz	$\pm 2.28\text{dB}$
	1-25GHz	$\pm 2.59\text{dB}$
Temperature	$\pm 0.8^\circ\text{C}$	$\pm 1^\circ\text{C}$
Humidity	$\pm 3\%$	$\pm 5\%$
DC and low frequency voltages	$\pm 3\%$	$\pm 3\%$



AC Conducted Measurement

Measurement	Frequency	Uncertainty
Conducted emissions(LINE)	9KHz-30MHz	+/- 0.7738 dB
Conducted emissions(NEUTRAL)	9KHz-30MHz	+/- 0.7886 dB
Conducted emissions(10Mbps)	150KHz-30MHz	+/- 1.3013dB
Conducted emissions(100Mbps)	150KHz-30MHz	+/- 1.3197 dB
Conducted emissions(1000Mbps)	150KHz-30MHz	+/- 1.2987 dB

Radiated Measurement

Measurement	Polarity	Frequency	Uncertainty
Radiated emissions	Horizontal	below 1GHz	+/- 3.8936 dB
	Vertical	below 1GHz	+/- 3.8928 dB
	Horizontal	above 1GHz	+/- 5.18858dB
	Vertical	above 1GHz	+/- 5.18928 dB



4. AC Conducted Emission Measurement

4.1 Test Limit

Conducted Emissions were measured from 150 kHz to 30 MHz with a bandwidth of 9 KHz on the 120 VAC power and return leads of the EUT according to the methods defined in ANSI C63.10-2013 Section 6.2. The EUT was placed on a nonmetallic stand in a shielded room 0.8 meters above the ground plane as shown in section 6.2.2. The interface cables and equipment positioning were varied within limits of reasonable applications to determine the position produced maximum conducted emissions.

FCC Part 15 Subpart C Paragraph 15.207 Limits		
Frequency (MHz)	Quasi Peak (dB μ V)	Average (dB μ V)
0.15 – 0.5	66-56*	56-46*
0.5 – 5.0	56	46
5.0 – 30.0	60	50

*Decreases with the logarithm of the frequency.

4.2 Test Standard

Tested according to ANSI C63.10: 2013 Section 6.2 for compliance to FCC 47CFR 15.247 Part15.207 (a) requirements.

4.3 Test Procedures

The EUT was placed on a platform of nominal size, 1 m by 1.5 m, raised 80 cm above the conducting ground plane. The vertical conducting plane was located 40 cm to the rear of the EUT. All other surfaces of EUT were at least 80 cm from any other grounded conducting surface. The EUT and simulators are connected to the main power through a line impedance stabilization network (LISN). The LISN provides a 50 ohm /50uH coupling impedance for the measuring equipment. The peripheral devices are also connected to the main power through a LISN. (Please refer to the block diagram of the test setup and photographs) Each current-carrying conductor of the EUT power cord, except the ground (safety) conductor, was individually connected through a LISN to the input power source.

The excess length of the power cord between the EUT and the LISN receptacle were folded back and forth at the center of the lead to form a bundle not exceeding 40 cm in length.

Conducted emissions were investigated over the frequency range from 0.15MHz to 30MHz using a receiver bandwidth of 9 kHz.



4.4 Test Setup Layout

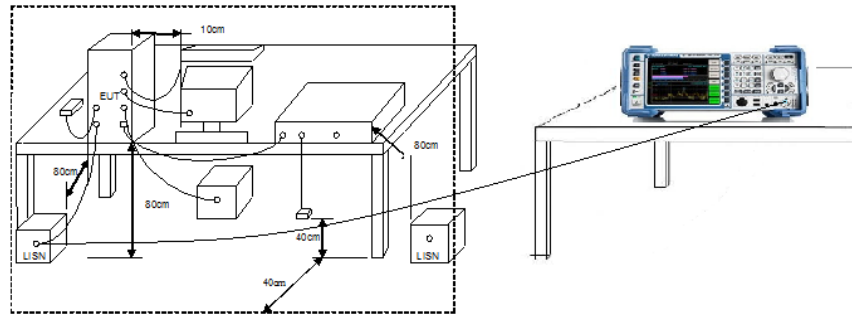



4.5 Test Result

Test Mode :	Mode 1: Normal Operation with BLE on		
AC Power :	AC 120V/60Hz	Phase:	LINE
Temperature :	26°C	Humidity:	60%
Pressure(mbar) :	1002	Date:	2017/06/29

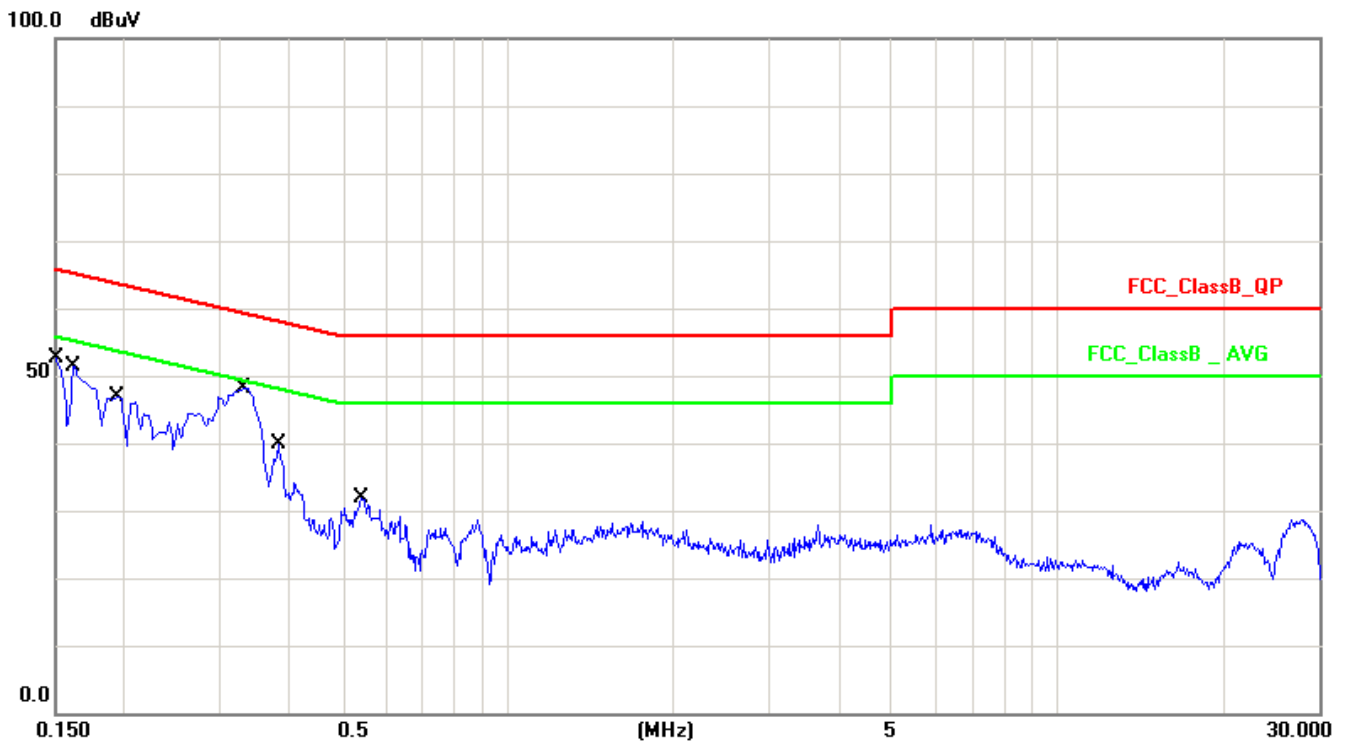

No.	Frequency (MHz)	Factor (dB)	Reading (dBuV)	Level (dBuV)	Limit (dBuV)	Margin (dB)	Detector
1	0.1500	10.13	40.15	50.28	65.99	-15.71	QP
2	0.1500	10.13	23.43	33.56	55.99	-22.43	AVG
3	0.1620	10.13	37.27	47.40	65.36	-17.96	QP
4	0.1620	10.13	18.91	29.04	55.36	-26.32	AVG
5	0.1945	10.12	33.17	43.29	63.84	-20.55	QP
6	0.1945	10.12	18.27	28.39	53.84	-25.45	AVG
7	0.3300	10.14	36.82	46.96	59.45	-12.49	QP
8	0.3300	10.14	29.23	39.37	49.45	-10.08	AVG
9	0.3820	10.15	25.58	35.73	58.23	-22.50	QP
10	0.3820	10.15	16.71	26.86	48.23	-21.37	AVG
11	0.5420	10.16	18.28	28.44	56.00	-27.56	QP
12	0.5420	10.16	9.13	19.29	46.00	-26.71	AVG

Note: Measurement Level = Reading Level + Correct Factor



Test Mode :	Mode 1: Normal Operation with BLE on		
AC Power :	AC 120V/60Hz	Phase :	NEUTRAL
Temperature :	26°C	Humidity :	60%
Pressure(mbar) :	1002	Date:	2017/06/29

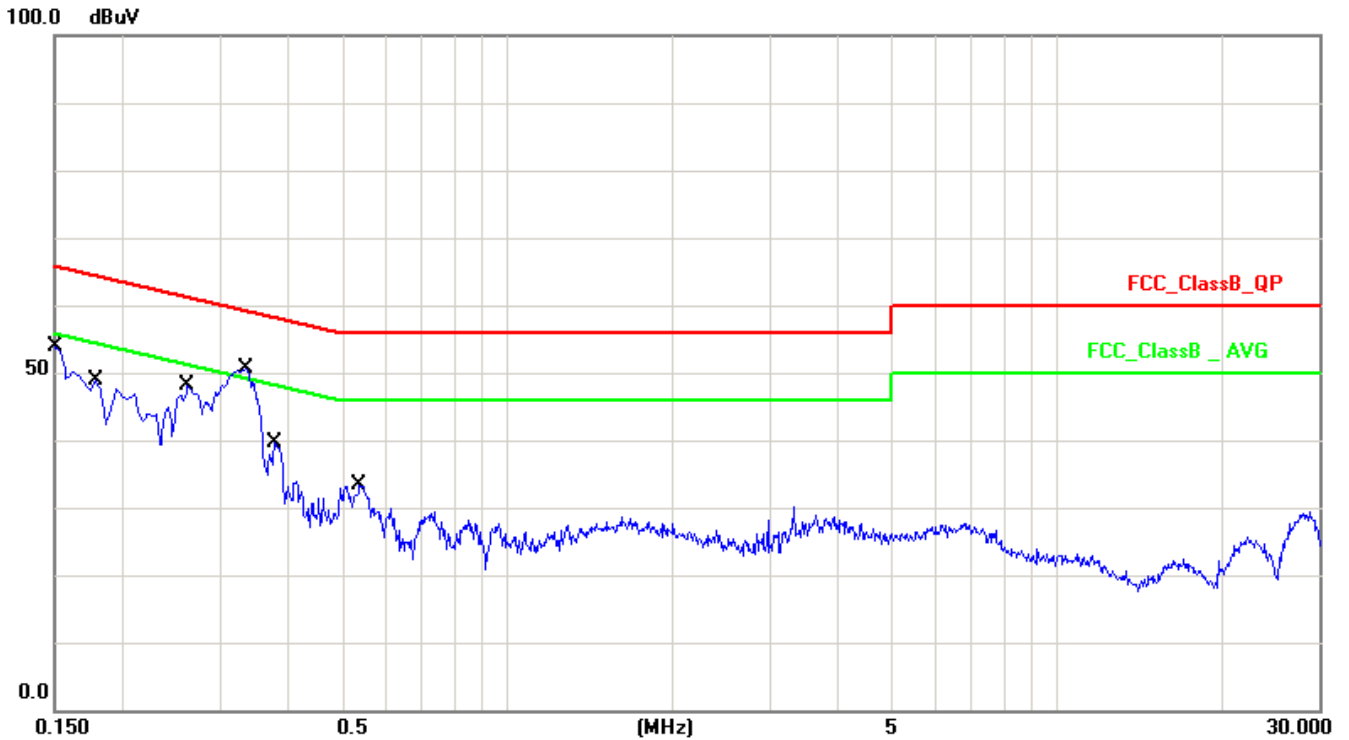

No.	Frequency (MHz)	Factor (dB)	Reading (dBuV)	Level (dBuV)	Limit (dBuV)	Margin (dB)	Detector
1	0.1500	10.13	40.51	50.64	65.99	-15.35	QP
2	0.1500	10.13	23.07	33.20	55.99	-22.79	AVG
3	0.1780	10.13	35.22	45.35	64.57	-19.22	QP
4	0.1780	10.13	16.43	26.56	54.57	-28.01	AVG
5	0.2620	10.13	33.56	43.69	61.36	-17.67	QP
6	0.2620	10.13	24.01	34.14	51.36	-17.22	AVG
7	0.3339	10.14	38.41	48.55	59.35	-10.80	QP
8	0.3339	10.14	29.12	39.26	49.35	-10.09	AVG
9	0.3780	10.15	26.33	36.48	58.32	-21.84	QP
10	0.3780	10.15	17.25	27.40	48.32	-20.92	AVG
11	0.5380	10.15	20.58	30.73	56.00	-25.27	QP
12	0.5380	10.15	11.82	21.97	46.00	-24.03	AVG

Note: Measurement Level = Reading Level + Correct Factor



5. Radiated Emission Measurement

5.1 Test Limit

In any 100kHz bandwidth outside the frequency band in which the spread spectrum or digitally modulated intentional radiator is operating, the radio frequency power that is produced by the intentional radiator shall be at least 20dB below that in the 100kHz bandwidth within the band that contains the highest level of the desired power, based on either an RF conducted or a radiated measurement. If the transmitter measurement is based on the maximum conducted output power, the attenuation required under this paragraph shall be 30dB instead of 20dB. In addition, radiated emissions which fall in section 15.205(a) the restricted bands must also comply with the radiated emission limit specified in section 15.209(a).

FCC Part 15 Subpart C Paragraph 15.209		
FREQUENCIES (MHz)	FIELD STRENGTH (micro volts/meter)	MEASUREMENT DISTANCE (meters)
0.009~0.490	2400/F(kHz)	300
0.490~1.705	24000/F(kHz)	30
1.705~30.0	30	30
30~88	100	3
88~216	150	3
216~960	200	3
Above 960	500	3

Note 1: The lower limit shall apply at the transition frequency.

Note 2: Distance refers to the distance in meters between the measuring instrument Antenna and the closed point of any part of the device or system.

Note 3: E field strength (dBuV/m) = 20 log E field strength (uV/m)

Note 4: **Except as provided in paragraph (g), fundamental emissions from intentional radiators operating under this section shall not be located in the frequency bands 54-72 MHz, 76-88 MHz, 174-216 MHz or 470-806 MHz. However, operation within these frequency bands is permitted under other sections of this part, e.g., §§15.231 and 15.241.

5.2 Test Standard

KDB 558074 D01v04 - Section 12.2.3 (quasi-peak measurements)

KDB 558074 D01v04 - Section 12.2.4 (peak power measurements)

KDB 558074 D01v04 - Section 12.2.5 (average power measurements)



5.3 Test Procedures

Quasi-Peak Field Strength Measurements:

The specifications for measurements using the CISPR quasi-peak detector can be found in Publication 16 of the International Special Committee on Radio Frequency Interference (CISPR) of the International Electrotechnical Commission.

As an alternative to CISPR quasi-peak measurement, compliance can be demonstrated to the applicable emission limits using a peak detector.

Peak Field Strength Measurements:

Analyzer center frequency was set to the frequency of the radiated spurious emission of interest

1. RBW=As specified in Table 1
2. VBW=3×RBW
3. Detector=Peak
4. Trace mode=Max hold
5. Sweep time=Auto couple
6. Allow the trace to stabilize

Table 1-RBW as a function of frequency

Frequency	RBW
9 ~ 150kHz	200 ~ 300Hz
0.15 ~ 30MHz	9 ~ 10kHz
30 ~ 1000MHz	100 ~ 120kHz
> 1000MHz	1MHz

AVE Field Strength Measurements:

Analyzer center frequency was set to the frequency of the radiated spurious emission of interest

1. RBW= 1MHz
2. VBW≥1/T
3. Detector=Peak
4. Trace mode=Max hold
5. Sweep time=Auto couple
6. Allow max hold to run for at least 50 times(1/duty cycle) trace

Do as an alternative, the instrument may be set to linear detector mode. Ensure that video filtering is applied in linear voltage domain (rather than in a log or dB domain). Some instruments require linear display mode in order to accomplish this. Others have a setting for Average-VBW Type, which can be set to “Voltage” regardless of the display mode



5.4 Test Setup Layout

9kHz~30MHz Test Setup

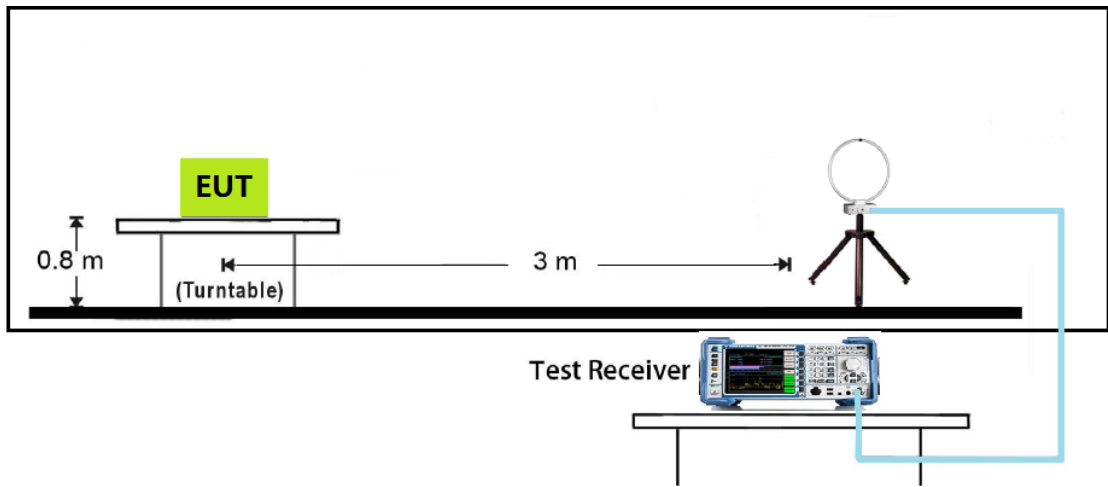

30MHz~1GHz Test Setup

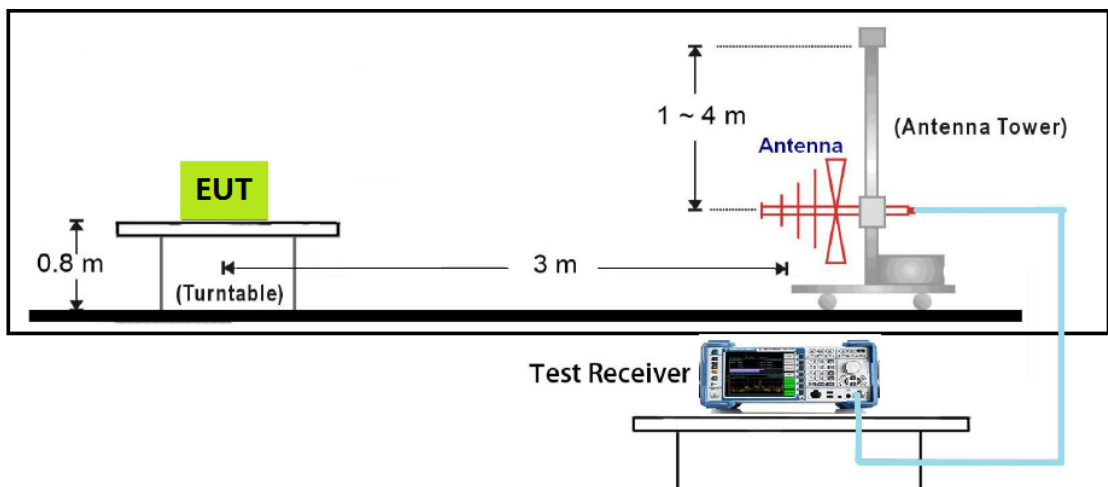



1GHz~18GHz Test Setup

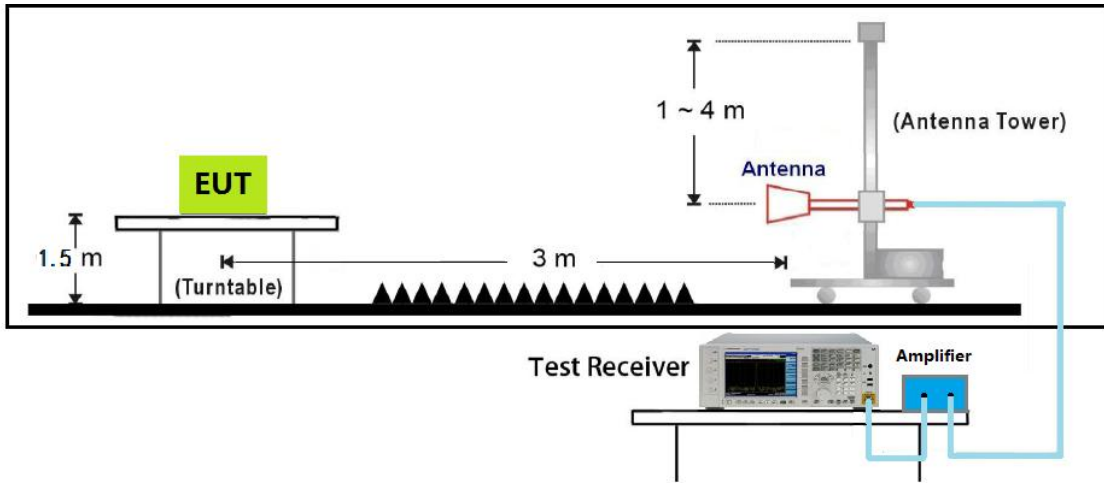

18GHz~40GHz Test Setup

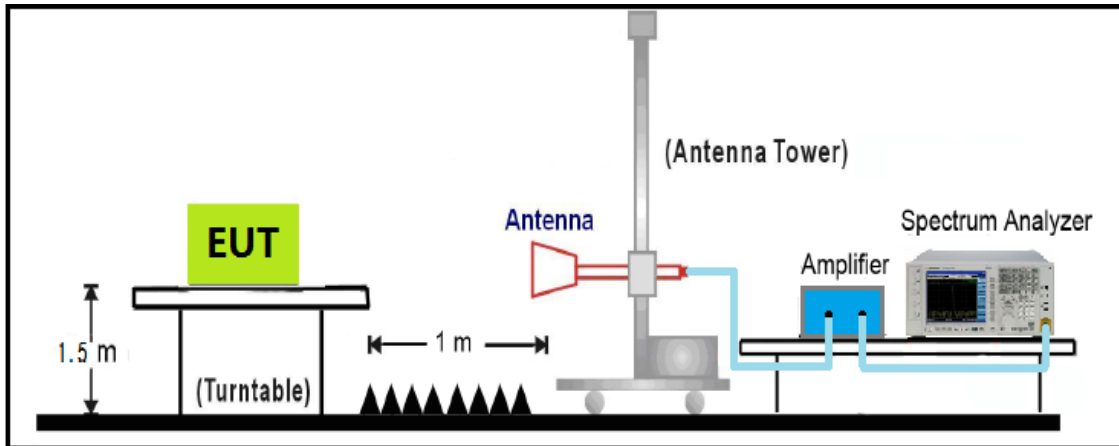



5.5 Test Result

The worst case of Radiated Emission below 1GHz:

Limit: FCC_Part15.209_RE(3m)	Margin: 0
Probe: HFH2-Z2 (9KHz-30MHz)	Polarity: Face on
EUT: Ninebot KickScooter	Power: AC 120V/60Hz
Note: There is the ambient noise within frequency range 9KHz-150KHz	

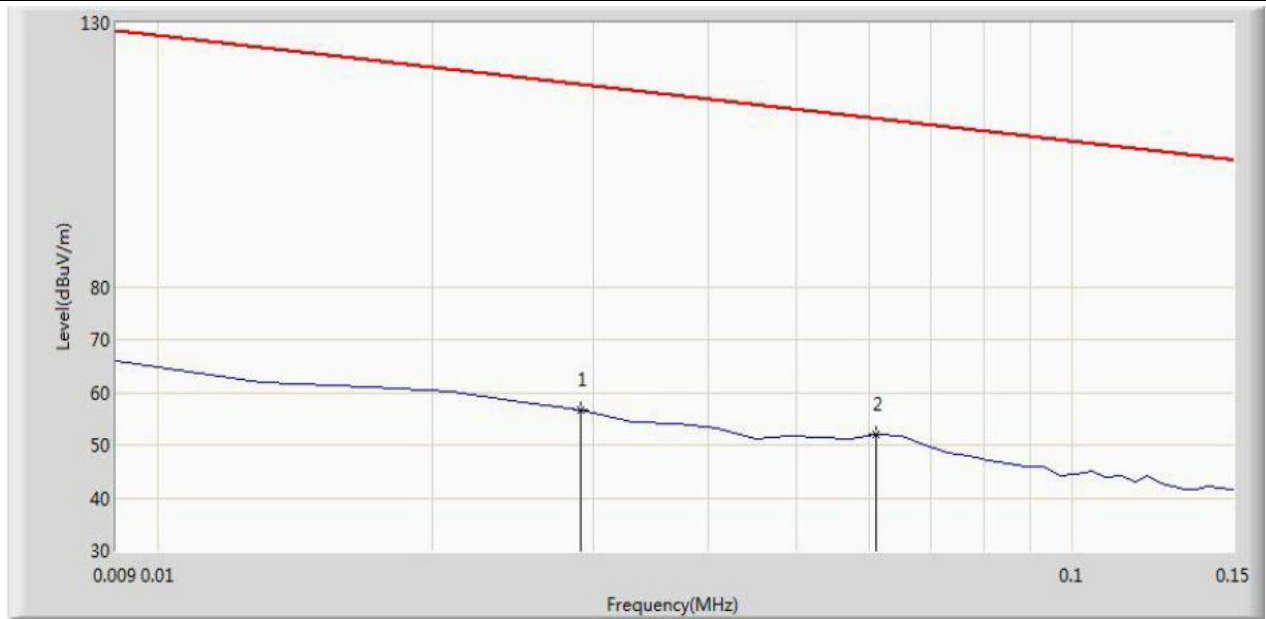

No.	Frequency (MHz)	Level (dBuV/m)	Reading (dBuV)	Margin (dB)	Limit (dBuV/m)	Factor (dB/m)	Det.
1	0.029	58.594	37.568	-59.768	118.342	21.026	QP
2	0.061	53.114	32.577	-58.823	111.887	20.537	QP

Note: Measure Level (dBuV/m) = Reading Level (dBuV) + Factor(dB).

Factor (dB)=Cable Loss(dB) + Antenna Factor (dB/m) - Pre_Amplifier Gain(dB)



Limit: FCC_Part15.209_RE(3m)	Margin: 0
Probe: HFH2-Z2 (9KHz-30MHz)	Polarity: Face on
EUT: Ninebot KickScooter	Power: AC 120V/60Hz
Note: There is the ambient noise within frequency range 150KHz-30MHz	

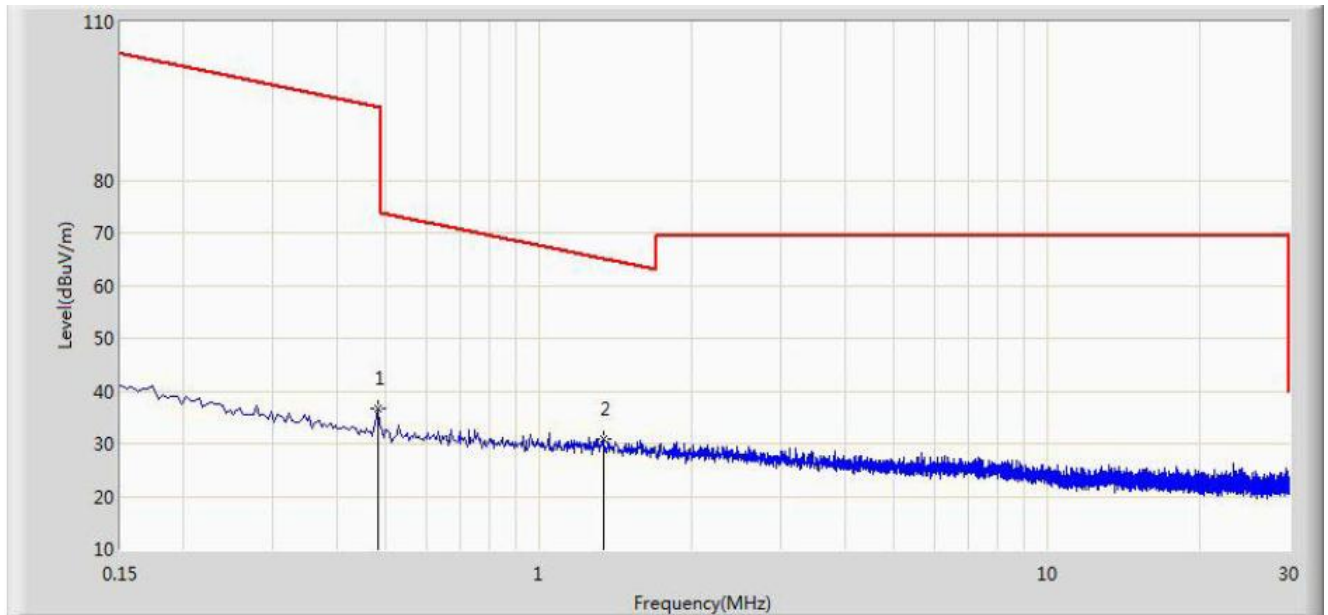

No.	Frequency (MHz)	Level (dBuV/m)	Reading (dBuV)	Margin (dB)	Limit (dBuV/m)	Factor (dB/m)	Det.
1	0.482	37.962	17.557	-56.001	93.943	20.405	QP
2	1.338	33.116	12.663	-31.963	65.099	20.453	QP

Note: Measure Level (dBuV/m) = Reading Level (dBuV) + Factor(dB).

Factor (dB)=Cable Loss(dB) + Antenna Factor (dB/m) - Pre_Amplifier Gain(dB)



Limit: FCC_Part15.209_RE(3m)	Margin: 0
Probe: CBL6112D (30-1000MHz)	Polarity: Horizontal
EUT: Ninebot KickScooter	Power: AC 120V/60Hz
Note: Mode1: Transmit at channel 2402MHz by BLE	

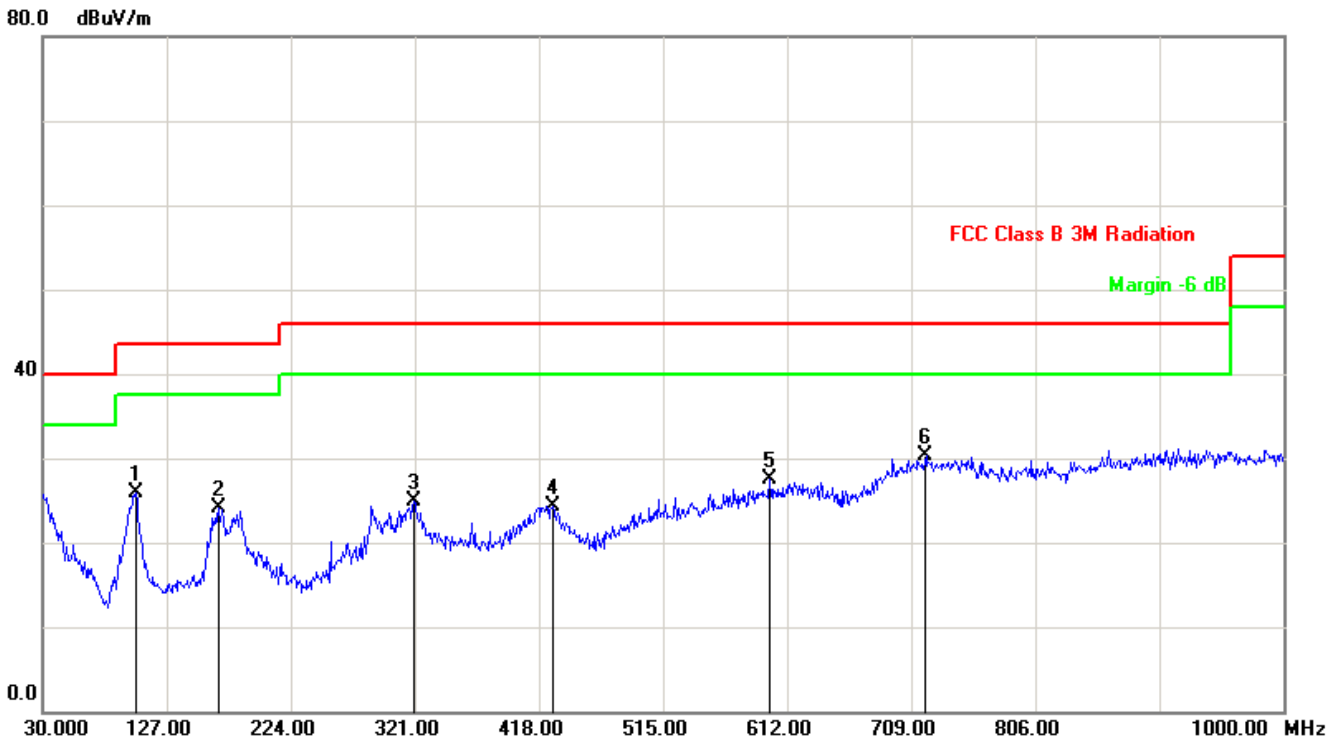

No.	Frequency (MHz)	Factor (dB/m)	Reading (dBuV)	Level (dBuV/m)	Limit (dBuV/m)	Margin (dB)	Det.
1	102.7500	-12.79	38.72	25.93	43.50	-17.57	PK
2	167.7400	-12.55	36.70	24.15	43.50	-19.35	PK
3	320.0299	-6.24	31.22	24.98	46.00	-21.02	PK
4	428.6700	-4.20	28.56	24.36	46.00	-21.64	PK
5	598.4199	-2.01	29.50	27.49	46.00	-18.51	PK
6	720.6399	1.39	29.01	30.40	46.00	-15.60	PK

Note: Measure Level (dBuV/m) = Reading Level (dBuV) + Factor(dB).

Factor (dB)=Cable Loss(dB) + Antenna Factor (dB/m) - Pre_Amplifier Gain(dB)



Limit: FCC_Part15.209_RE(3m)	Margin: 0
Probe: CBL6112D (30-1000MHz)	Polarity: Vertical
EUT: Ninebot KickScooter	Power: AC 120V/60Hz
Note: Mode1: Transmit at channel 2402MHz by BLE	

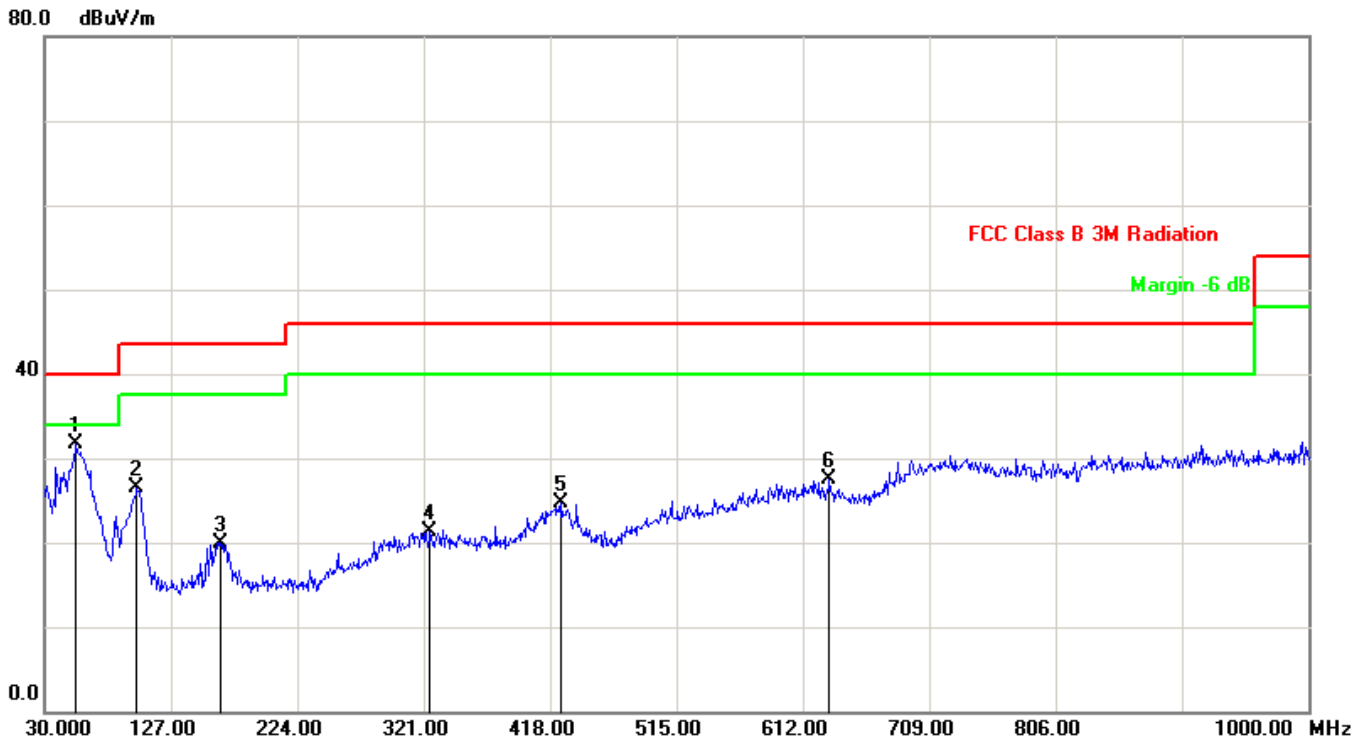

No.	Frequency (MHz)	Factor (dB/m)	Reading (dBuV)	Level (dBuV/m)	Limit (dBuV/m)	Margin (dB)	Det.
1	54.2500	-11.69	43.37	31.68	40.00	-8.32	PK
2	100.8100	-12.79	39.20	26.41	43.50	-17.09	PK
3	164.8300	-12.52	32.52	20.00	43.50	-23.50	PK
4	325.8500	-6.34	27.56	21.22	46.00	-24.78	PK
5	426.7300	-3.99	28.69	24.70	46.00	-21.30	PK
6	632.3700	-1.73	29.31	27.58	46.00	-18.42	PK

Note: Measure Level (dBuV/m) = Reading Level (dBuV) + Factor(dB).

Factor (dB)=Cable Loss(dB) + Antenna Factor (dB/m) - Pre_Amplifier Gain(dB)



Above 1GHz

Limit: FCC_Part15.209_RE(3m)	Margin: 0
Probe: BBHA9120D_1-18GHz	Polarity: Horizontal
EUT: Ninebot KickScooter	Power: AC 120V/60Hz
Note: mode:Transimt BLE at 2402MHz	

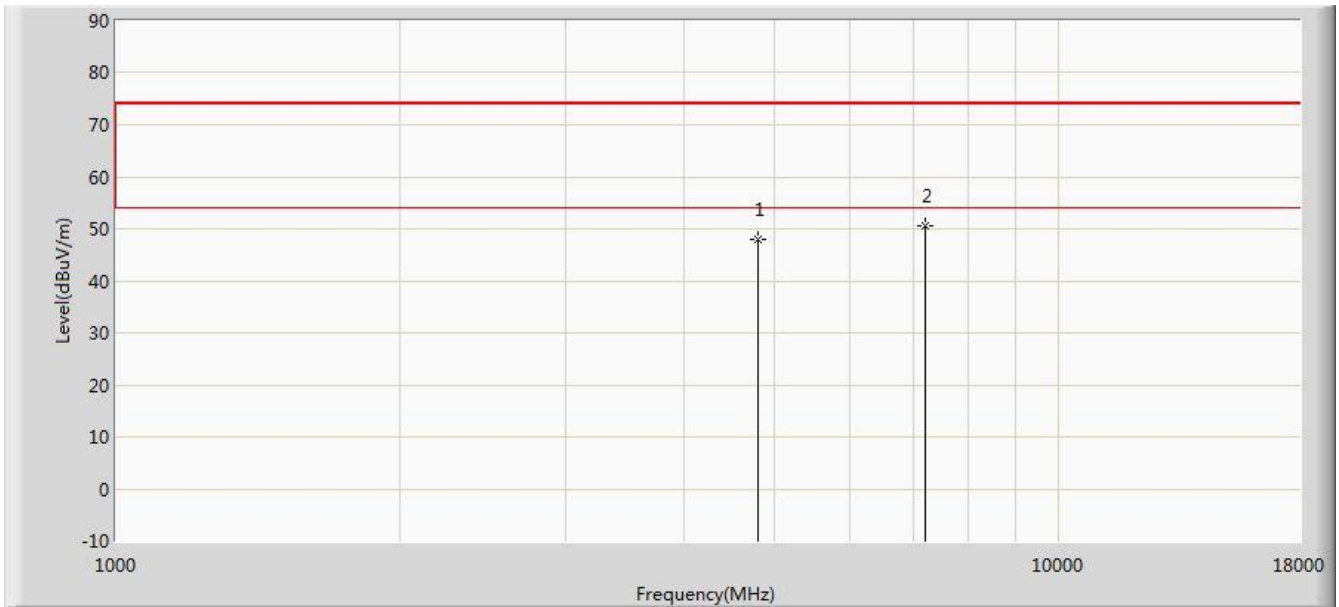

No	Mark	Frequency (MHz)	Measure Level (dBuV/m)	Reading Level (dBuV)	Over Limit (dB)	Limit (dBuV/m)	Factor (dB)	Type
1		4804.000	47.923	44.641	-26.077	74.000	3.282	PK
2	*	7206.000	50.615	42.420	-23.385	74.000	8.195	PK



Limit: FCC_Part15.209_RE(3m)	Margin: 0
Probe: BBHA9120D_1-18GHz	Polarity: Vertical
EUT: Ninebot KickScooter	Power: AC 120V/60Hz
Note: mode:Transimt BLE at 2402MHz	

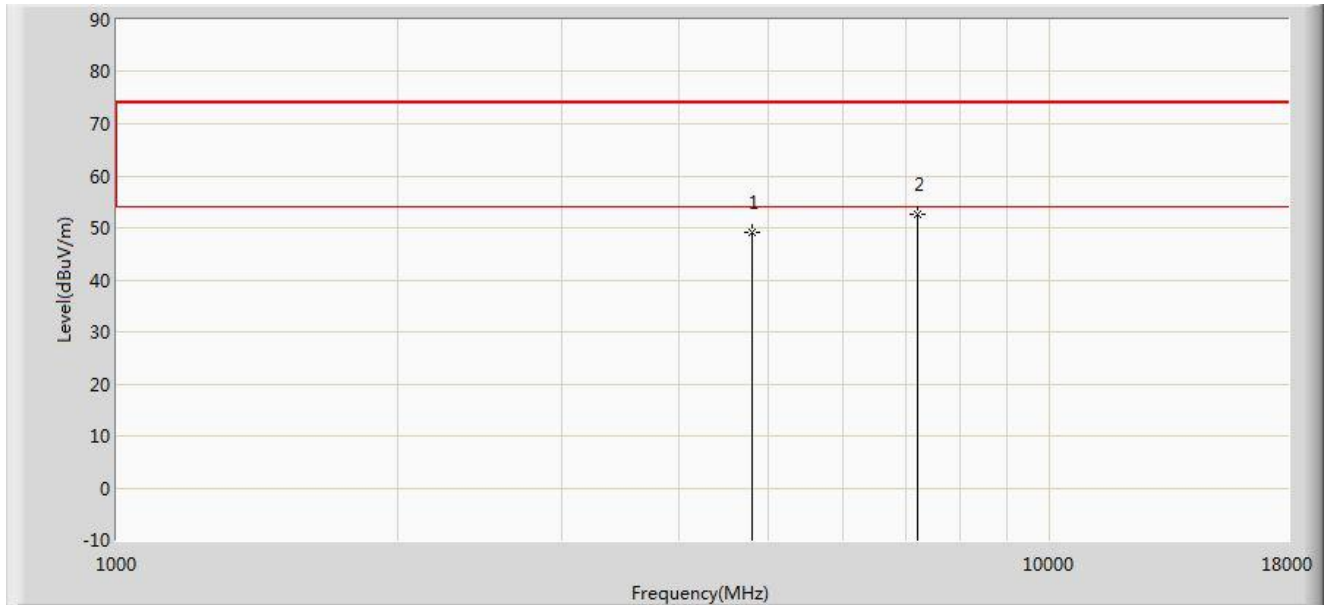

No	Mark	Frequency (MHz)	Measure Level (dBuV/m)	Reading Level (dBuV)	Over Limit (dB)	Limit (dBuV/m)	Factor (dB)	Type
1		4804.000	48.994	45.712	-25.006	74.000	3.282	PK
2	*	7206.000	52.695	44.500	-21.305	74.000	8.195	PK



Limit: FCC_Part15.209_RE(3m)	Margin: 0
Probe: BBHA9120D_1-18GHz	Polarity: Horizontal
EUT: Ninebot KickScooter	Power: AC 120V/60Hz
Note: mode:Transimt BLE at 2440MHz	

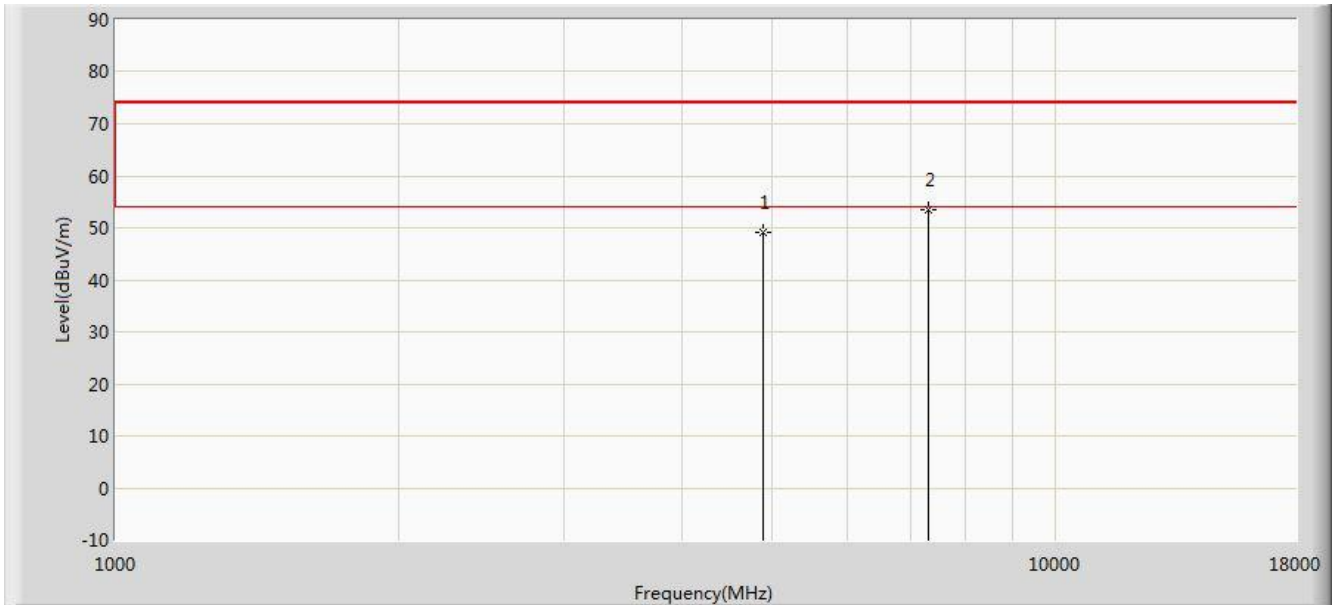

No	Mark	Frequency (MHz)	Measure Level (dBuV/m)	Reading Level (dBuV)	Over Limit (dB)	Limit (dBuV/m)	Factor (dB)	Type
1		4880.000	49.096	45.664	-24.904	74.000	3.432	PK
2	*	7320.000	53.524	45.250	-20.476	74.000	8.274	PK



Limit: FCC_Part15.209_RE(3m)	Margin: 0
Probe: BBHA9120D_1-18GHz	Polarity: Vertical
EUT: Ninebot KickScooter	Power: AC 120V/60Hz
Note: mode:Transimt BLE at 2440MHz	

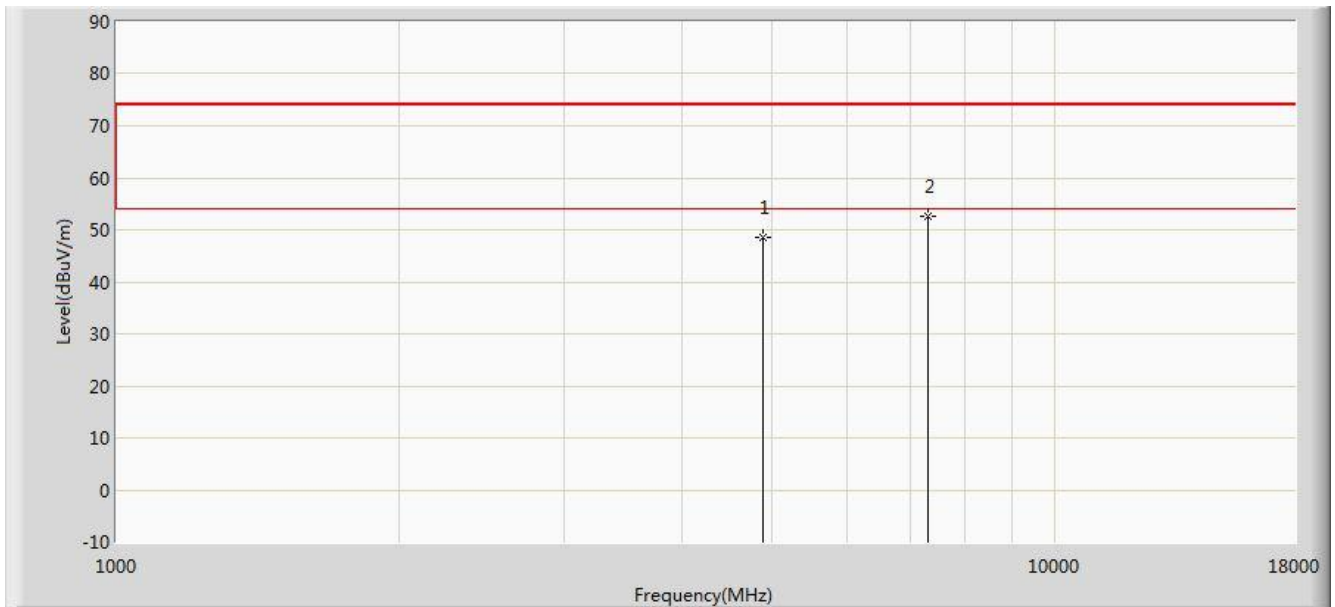

No	Mark	Frequency (MHz)	Measure Level (dBuV/m)	Reading Level (dBuV)	Over Limit (dB)	Limit (dBuV/m)	Factor (dB)	Type
1		4880.000	48.509	45.077	-25.491	74.000	3.432	PK
2	*	7332.500	52.468	44.185	-21.532	74.000	8.283	PK



Limit: FCC_Part15.209_RE(3m)	Margin: 0
Probe: BBHA9120D_1-18GHz	Polarity: Horizontal
EUT: Ninebot KickScooter	Power: AC 120V/60Hz
Note: mode:Transimt BLE at 2480MHz	

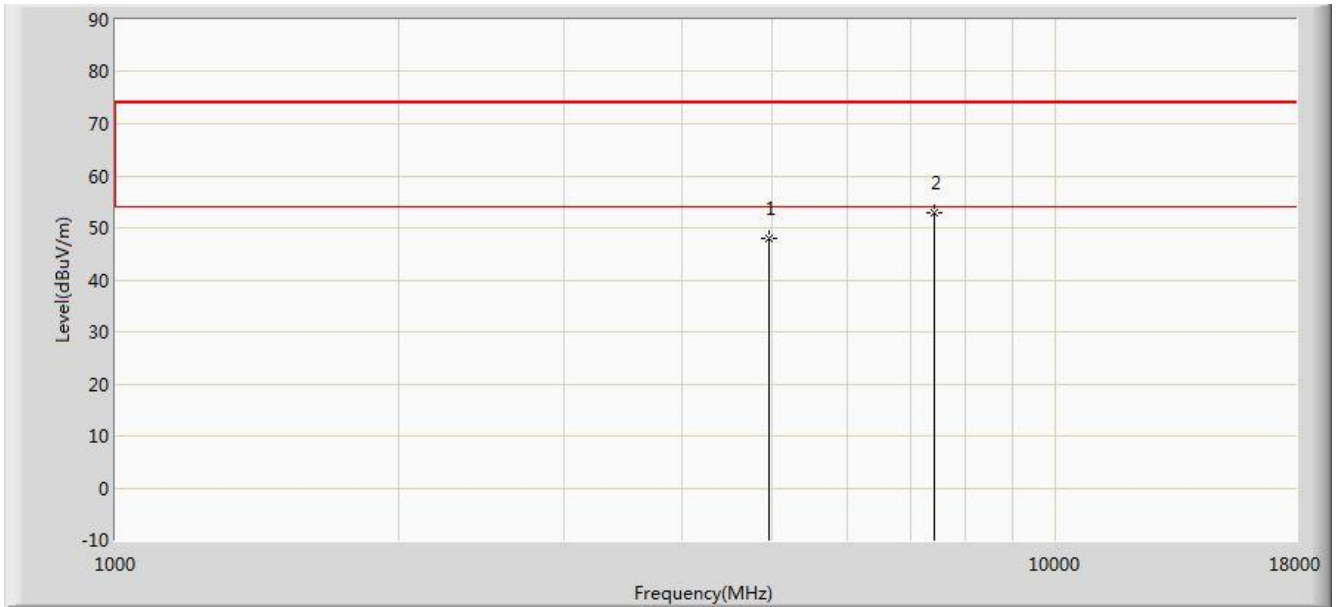

No	Mark	Frequency (MHz)	Measure Level (dBuV/m)	Reading Level (dBuV)	Over Limit (dB)	Limit (dBuV/m)	Factor (dB)	Type
1		4960.000	47.921	44.330	-26.079	74.000	3.591	PK
2	*	7440.000	52.866	44.508	-21.134	74.000	8.358	PK



Limit: FCC_Part15.209_RE(3m)	Margin: 0
Probe: BBHA9120D_1-18GHz	Polarity: Vertical
EUT: Ninebot KickScooter	Power: AC 120V/60Hz
Note: mode:Transimt BLE at 2480MHz	

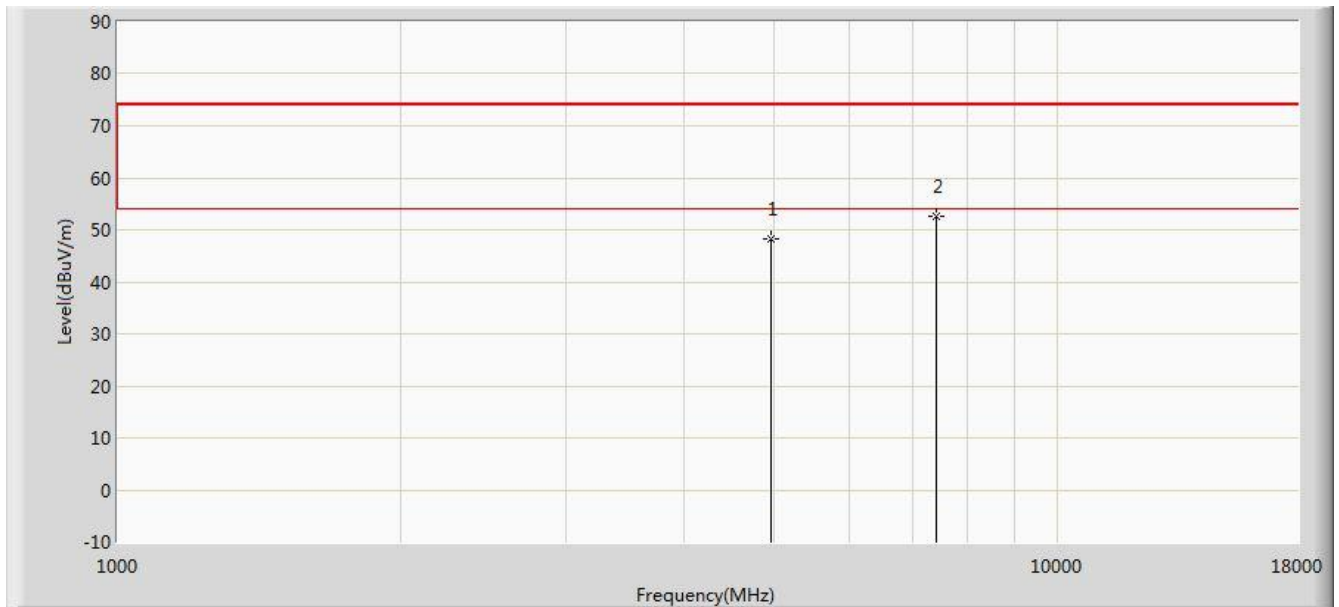

No	Mark	Frequency (MHz)	Measure Level (dBuV/m)	Reading Level (dBuV)	Over Limit (dB)	Limit (dBuV/m)	Factor (dB)	Type
1		4960.000	48.292	44.701	-25.708	74.000	3.591	PK
2	*	7440.000	52.722	44.364	-21.278	74.000	8.358	PK

Note: Measure Level (dBuV/m) = Reading Level (dBuV) + Factor(dB).

Factor (dB)=Cable Loss(dB) + Antenna Factor (dB/m) - Pre_Amplifier Gain(dB)



Radiated Emission above 1GHz:

Limit: FCC_Part15.209_RE(3m)	Margin: 0
Probe: BBHA9170 (18GHz-40GHz)	Polarity: Horizontal
EUT: Ninebot KickScooter	Power: AC 120V/60Hz
Note: There is the ambient noise within frequency range 18GHz-40GHz	

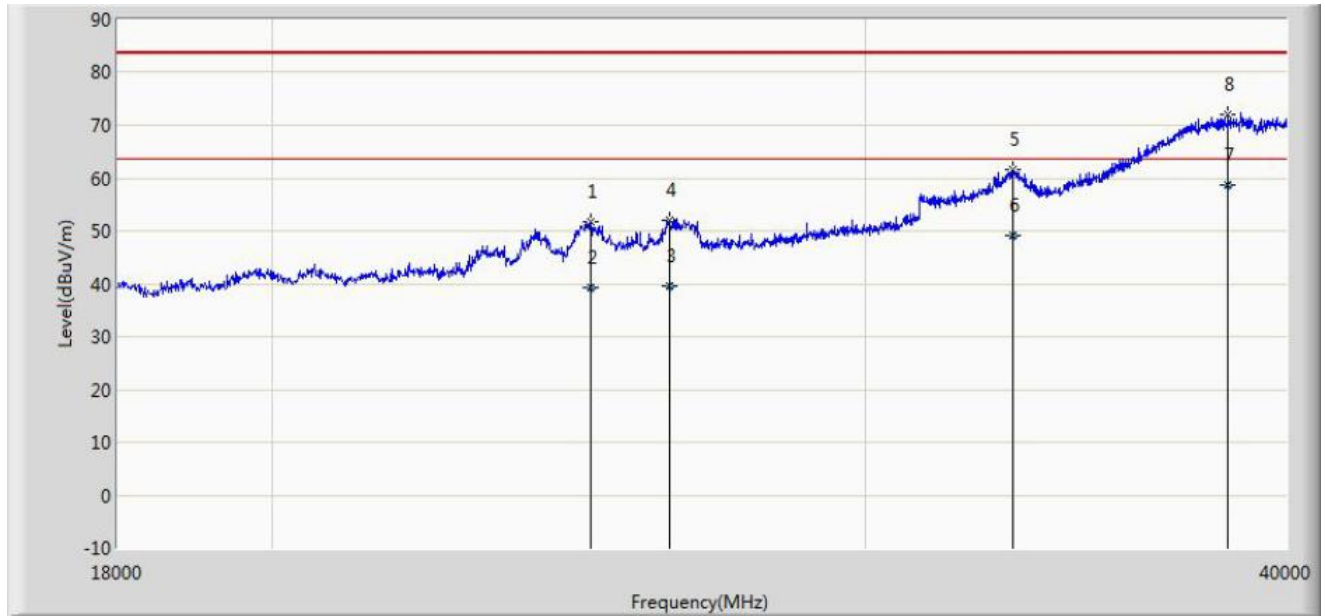

No	Mark	Frequency	Measure Level	Reading Level	Over Limit	Limit	Factor	Type
		(MHz)	(dBuV/m)	(dBuV)	(dB)	(dBuV/m)	(dB)	
1		24864.000	51.879	37.104	-31.624	83.500	14.775	PK
2		24864.083	39.257	24.482	-24.245	63.500	14.775	AV
3		26260.983	39.505	24.086	-23.991	63.500	15.419	AV
4		26261.003	51.992	36.573	-31.504	83.500	15.419	PK
5		33180.000	61.503	39.982	-21.999	83.500	21.521	PK
6		33180.363	49.084	27.563	-14.419	63.500	21.521	AV
7	*	38437.980	58.566	31.233	-4.937	63.500	27.333	AV
8		38438.000	72.069	44.736	-11.429	83.500	27.333	PK

Note: Measure Level (dBuV/m) = Reading Level (dBuV) + Factor(dB).

Factor (dB)=Cable Loss(dB) + Antenna Factor (dB/m) - Pre_Amplifier Gain(dB)

Limit@1m = 20*Log(500uV/m) + 20*Log(3m/1m) = 63.5dBµv/m (Average detector), and 83.5dBµv/m (Peak detector).



Limit: FCC_Part15.209_RE(3m)	Margin: 0
Probe: BBHA9170 (18GHz-40GHz)	Polarity: Vertical
EUT: Ninebot KickScooter	Power: AC 120V/60Hz
Note: There is the ambient noise within frequency range 18GHz-40GHz	

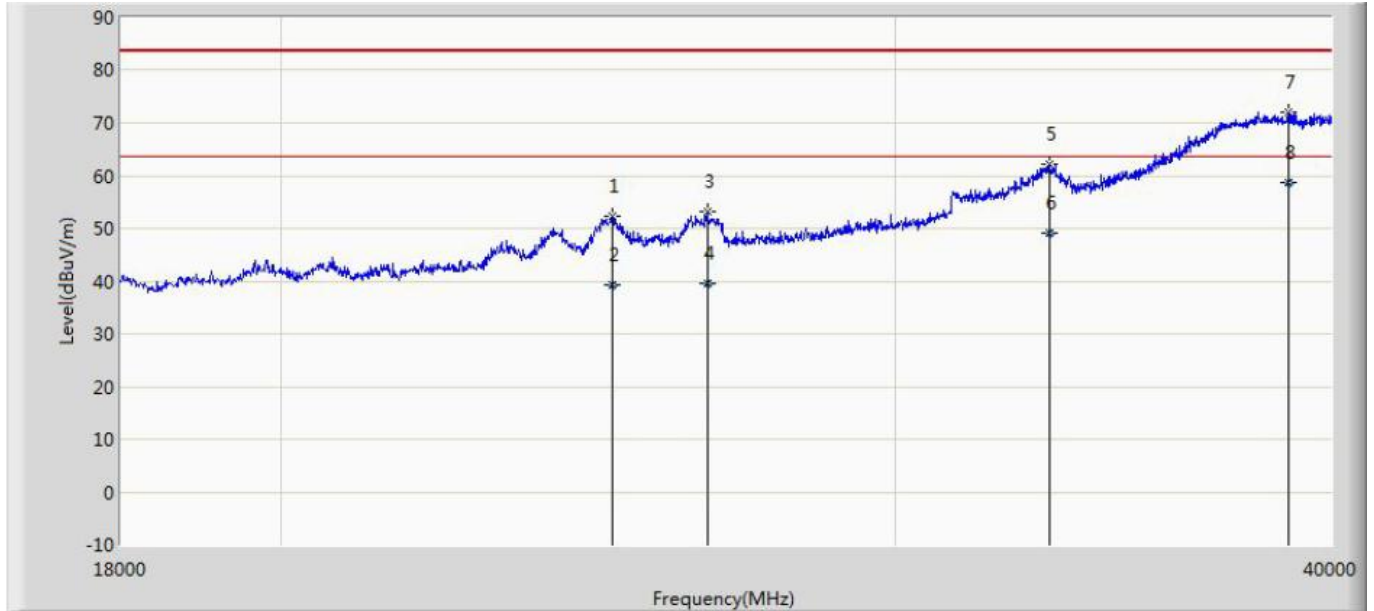

No	Mark	Frequency	Measure Level	Reading Level	Over Limit	Limit	Factor	Type
		(MHz)	(dBuV/m)	(dBuV)	(dB)	(dBuV/m)	(dB)	
1		24886.000	52.351	37.566	-31.137	83.500	14.785	PK
2		24886.970	39.071	24.286	-24.226	63.500	14.785	AV
3		26503.000	53.265	37.245	-30.233	83.500	16.020	PK
4		26503.877	39.624	23.604	-23.868	63.500	16.020	AV
5		33213.000	62.160	40.622	-21.331	83.500	21.538	PK
6		33213.989	49.123	27.585	-14.372	63.500	21.538	AV
7		38900.000	72.132	44.247	-11.264	83.500	27.885	PK
8	*	38900.756	58.749	30.864	-4.745	63.500	27.885	AV

Note: Measure Level (dBuV/m) = Reading Level (dBuV) + Factor(dB).

Factor (dB)=Cable Loss(dB) + Antenna Factor (dB/m) - Pre_Amplifier Gain(dB)

Limit@1m = 20*Log(500uV/m) + 20*Log(3m/1m) = 63.5dBµV/m (Average detector), and 83.5dBµV/m (Peak detector).



6. 6dB Bandwidth Measurement

6.1 Test Limit

According to FCC part15.247 - Section (a)(2), the minimum 6dB bandwidth shall be at least 500 kHz.

6.2 Test Standard

KDB 558074 D01v4 – Section 8.2 Option 2

6.3 Test Procedures

1. Set RBW=100KHz
2. VBW \geq 3 \times RBW
3. Detector=Peak
4. Trace mode=Max hold
5. Sweep time=Auto couple
6. Allow the trace to stabilize
7. The Spectrum's automatic bandwidth measurement capability was used to perform the 6dB bandwidth measurement. The "X" dB bandwidth parameter was set to X = 6. The bandwidth measurement was not influenced by any intermediate power nulls in the fundamental emission.

6.4 Test Setup Layout

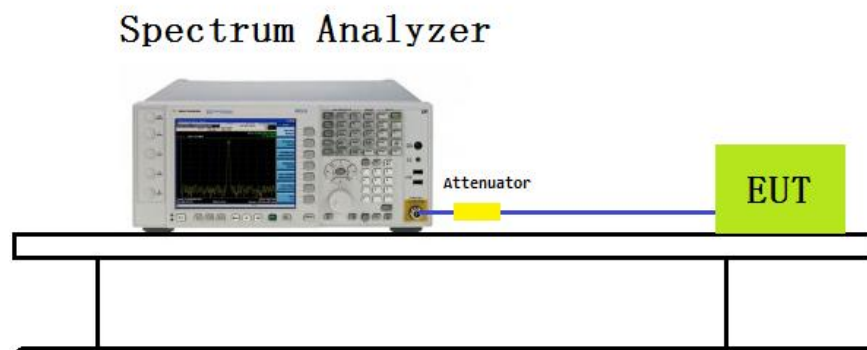



6.5 Test Result

Test Item	Occupied Bandwidth
Test Mode	Mode 1: Transmit by BLE

Channel No.	Frequency(MHz)	6dB Bandwidth(kHz)	99% Bandwidth(MHz)
0	2402	707.1	2.0888
19	2440	718.6	2.1171
39	2480	691.2	2.0187

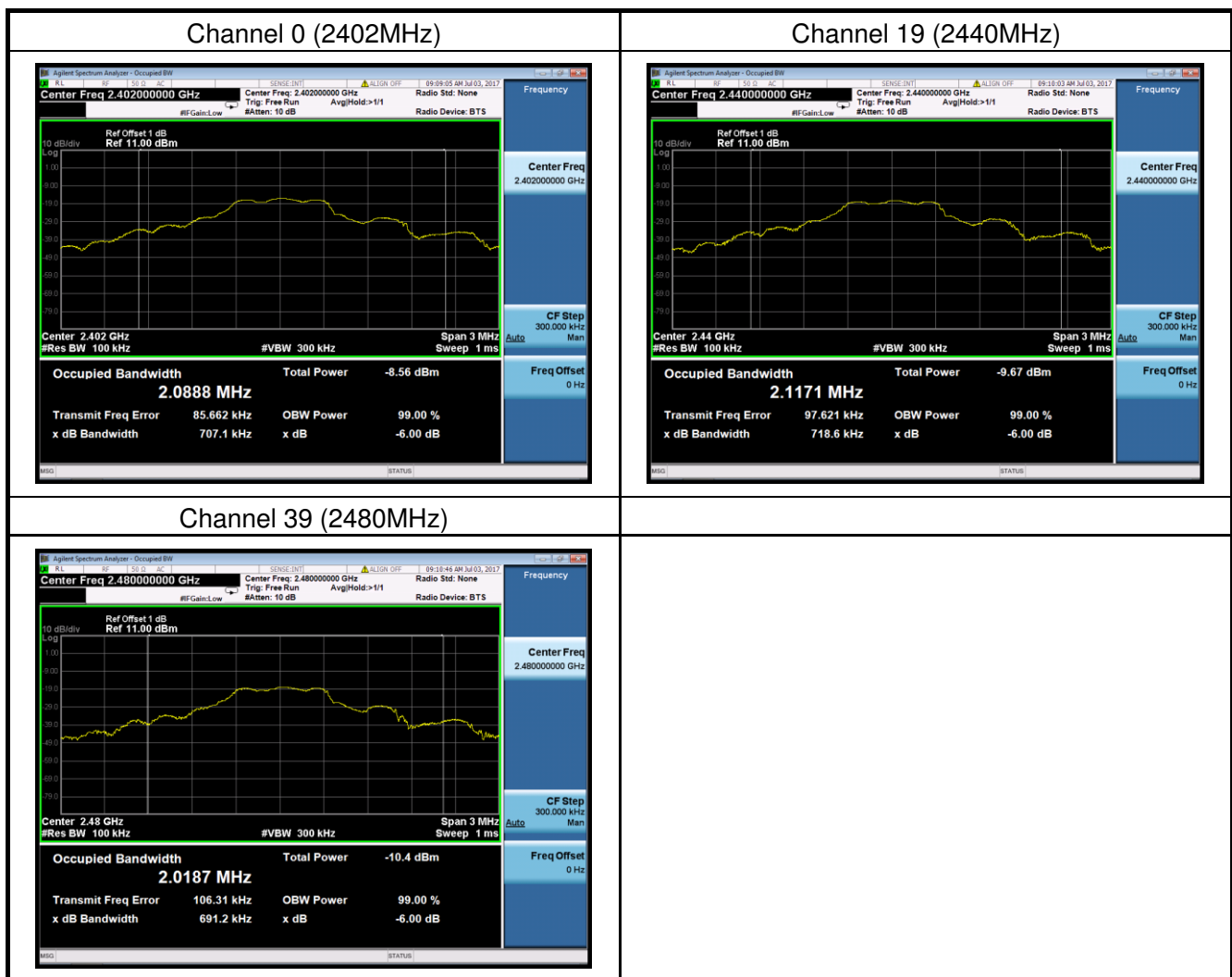



7. Output Power Measurement

7.1 Test Limit

According to FCC part15.247 (b) (3), for systems using digital modulation in the 902-928 MHz, 2400-2483.5 MHz, and 5725-5850MHz bands: 1 Watt. As an alternative to a peak power measurement, compliance with the one Watt limit can be based on a measurement of the maximum conducted output power. Maximum Conducted Output Power is defined as the total transmit power delivered to all antennas and antenna elements averaged across all symbols in the signaling alphabet when the transmitter is operating at its maximum power control level. Power must be summed across all antennas and antenna elements. The average must not include any time intervals during which the transmitter is off or is transmitting at a reduced power level. If multiple modes of operation are possible (e.g., alternative modulation methods), the maximum conducted output power is the highest total transmit power occurring in any mode.

Per RSS247 Issue 2 Section 5.4(d), for DTSs employing digital modulation techniques operating in the bands 902-928 MHz and 2400-2483.5 MHz, the maximum peak conducted output power shall not exceed 1W.

7.2 Test Standard

KDB 558074 D01v04 - Section 9.1.2 PKPM1 Peak Power Method (for signals with BW \leq 50MHz)

7.3 Test Procedures

Out power measurements were performed only when the EUT was transmitting at its maximum power control level using a broadband power meter with a pulse sensor. The pulse sensor employs a VBW = 50MHz so this method was only used for signals whose DTS bandwidth was less than or equal to 50MHz.

7.4 Test Setup Layout

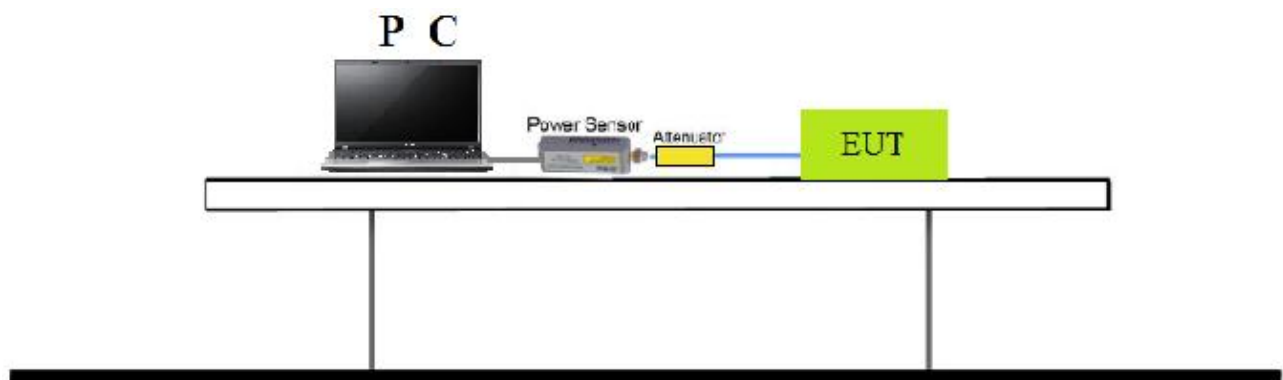



7.5 Test Result

For Peak Power :

Test Mode	Channel No.	Frequency (MHz)	Peak Output Power (dBm)	Limit (dBm)	Result
BLE	0	2402	-14.697	30	Pass
	19	2440	-15.615	30	Pass
	39	2480	-16.767	30	Pass

For Average Power :

Test Mode	Channel No.	Frequency (MHz)	Average Output Power (dBm)	Limit (dBm)	Result
BLE	0	2402	-14.817	30	Pass
	19	2440	-15.742	30	Pass
	39	2480	-16.891	30	Pass



8. Power Spectral Density Measurement

8.1 Test Limit

According to FCC part15.247 - Section (e), for digitally modulated systems, the power spectral density conducted from the intentional radiator to the antenna shall not be greater than 8 dBm in any 3 kHz band during any time interval of continuous transmission. This power spectral density shall be determined in accordance with the provisions of paragraph (b) of this section. The same method of determining the conducted output power shall be used to determine the power spectral density.

8.2 Test Standard

KDB 558074 D01v04 - Section 10.2 Method PKPSD

8.3 Test Procedures

1. Set RBW=3kHz
2. Set RBW=10kHz
3. Span = 1.5 times the DTS channel bandwidth
4. Detector=Peak
5. Trace mode=Max hold
6. Sweep time=Auto couple
7. Allow the trace to stabilize
8. Analyzer was set to the center frequency of the DTS channel under investigation.

8.4 Test Setup Layout

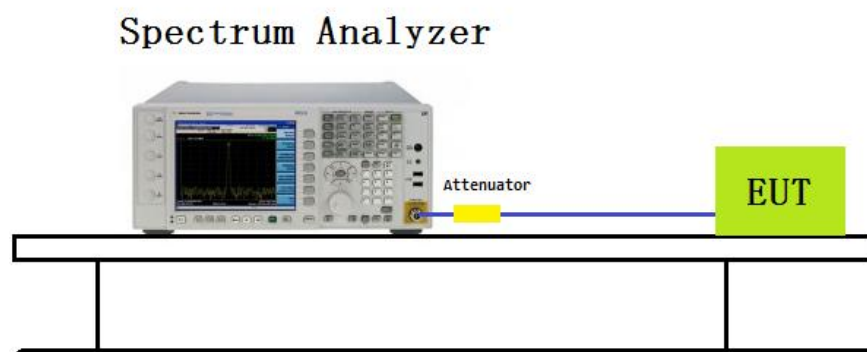



8.5 Test Result

Test Item	Power Spectral Density
Test Mode	Mode 1: Transmit by BLE

Channel No.	Frequency(MHz)	Power Spectral Density (dBm/3kHz)	Limit (dBm/3kHz)	Result
0	2402	-16.758	8	Pass
19	2440	-17.434	8	Pass
39	2480	-17.959	8	Pass

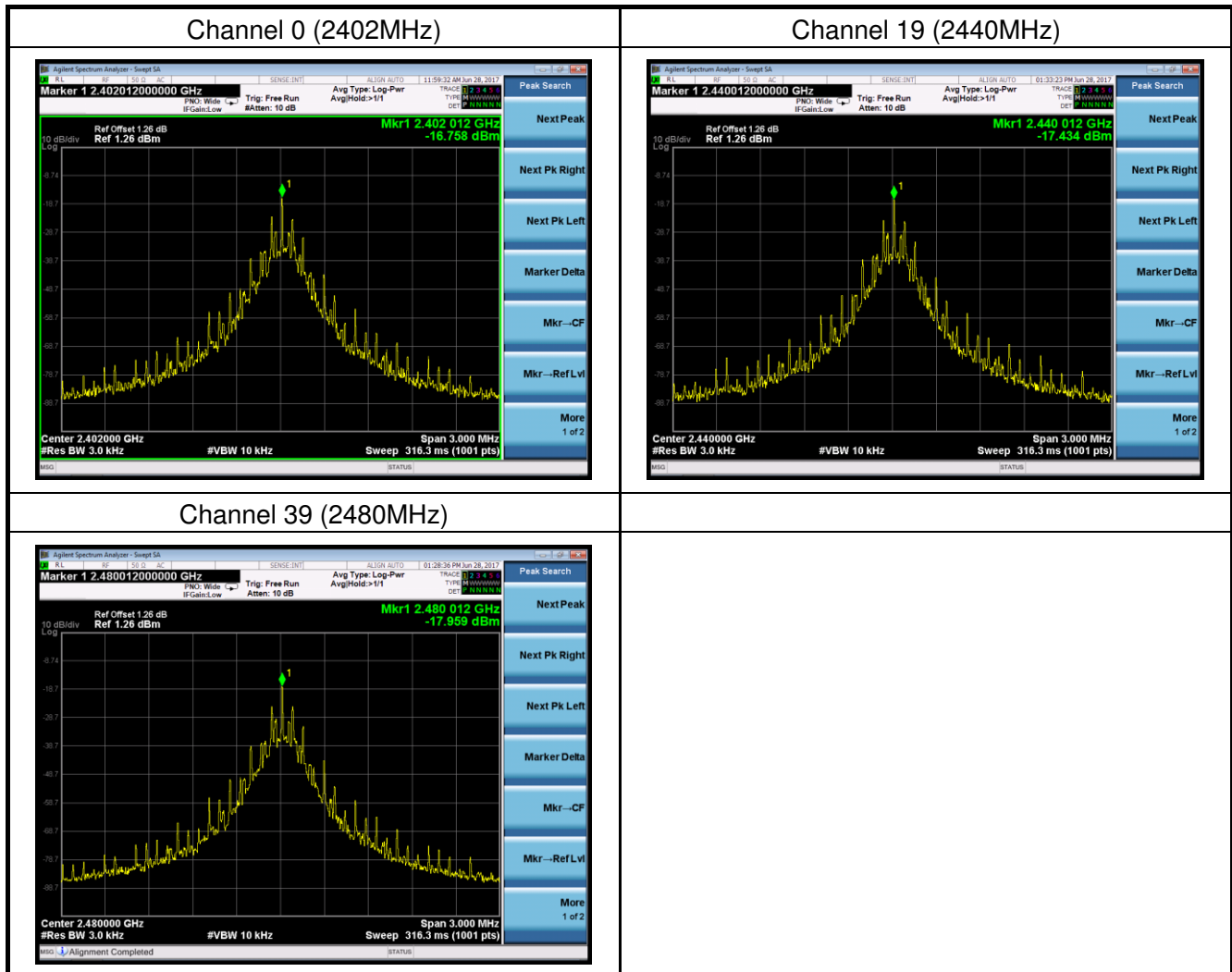



9. Conducted Band Edge and Out-of-Band Emissions Measurement

9.1 Test Limit

According to FCC part 15.247(d) , in any 100 kHz bandwidth outside the frequency band in which the spread spectrum or digitally modulated intentional radiator is operating, the radio frequency power that is produced by the intentional radiator shall be at least 20 dB below that in the 100 kHz bandwidth within the band that contains the highest level of the desired power, based on either an RF conducted or a radiated measurement, provided the transmitter demonstrates compliance with the peak conducted or a radiated measurement, provided the transmitter demonstrates compliance with the peak conducted power limits. If the transmitter complies with the conducted power limits based on the use of RMS averaging over a time interval, the attenuation required under this paragraph shall be 30 dB instead of 20 dB. Attenuation below the general limits specified in Section 15.209(a) of FCC part 15 is not required.

9.2 Test Standard

KDB 558074 D01v04 - Section 11.2 & Section 11.3



9.3 Test Procedures

Reference level measurement:

1. Set the RBW = 100 kHz
2. Set the VBW $\geq 3 \times$ RBW
3. Set the span to ≥ 1.5 times the DTS bandwidth
4. Detector = peak
5. Trace mode = max hold
6. Sweep time = auto couple
7. Allow trace to fully stabilize
8. Set instrument center frequency to DTS channel center frequency

Emission level measurement:

1. RBW = 100kHz
2. VBW = 300kHz
3. Detector = Peak
4. Trace mode = max hold
5. Sweep time = auto couple
6. The trace was allowed to stabilize
7. Set the center frequency and span to encompass frequency range to be measured

9.4 Test Setup Layout

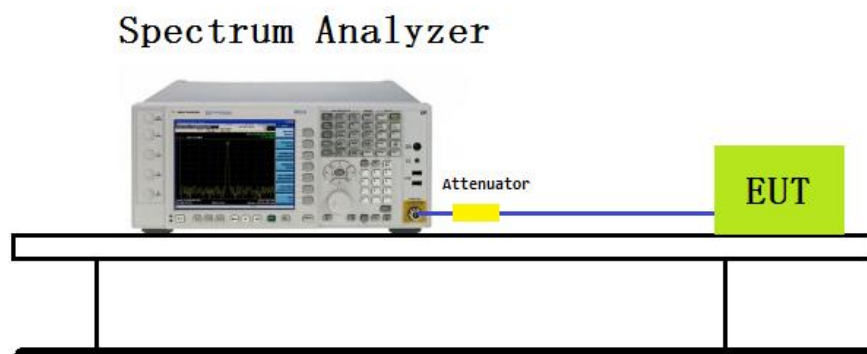



9.5 Test Result

Test Mode	Channel No.	Frequency (MHz)	Limit	Result
BLE	0	2402	20dBc	Pass
	19	2440	20dBc	Pass
	39	2480	20dBc	Pass



Test Item	:	Conducted Band Edge and Out-of-Band Emissions
Test Mode	:	Mode 1: Transmit by BLE

Mode 1: Transmit by BLE (2402MHz)

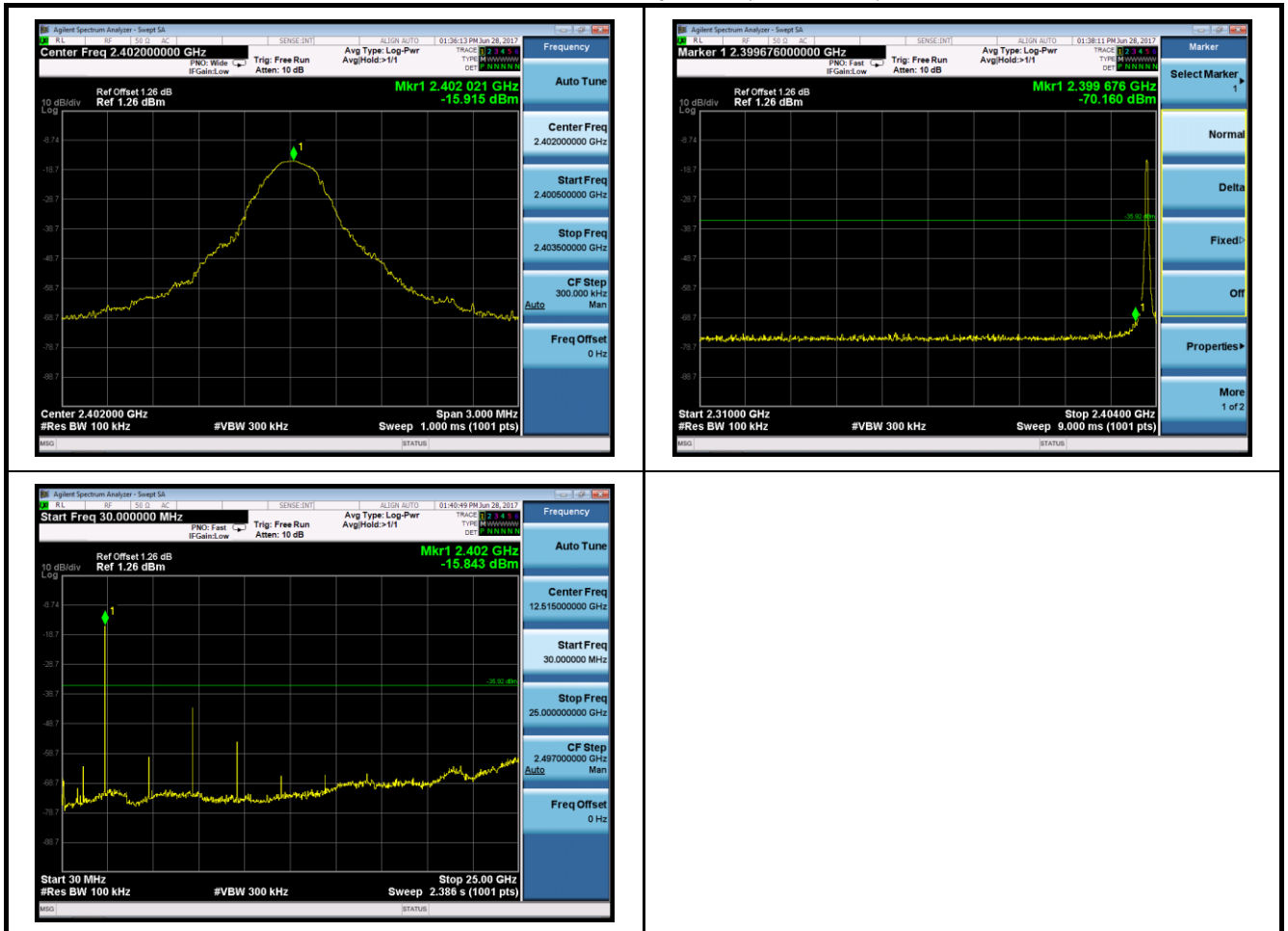



Mode 1: Transmit by BLE (2440MHz)

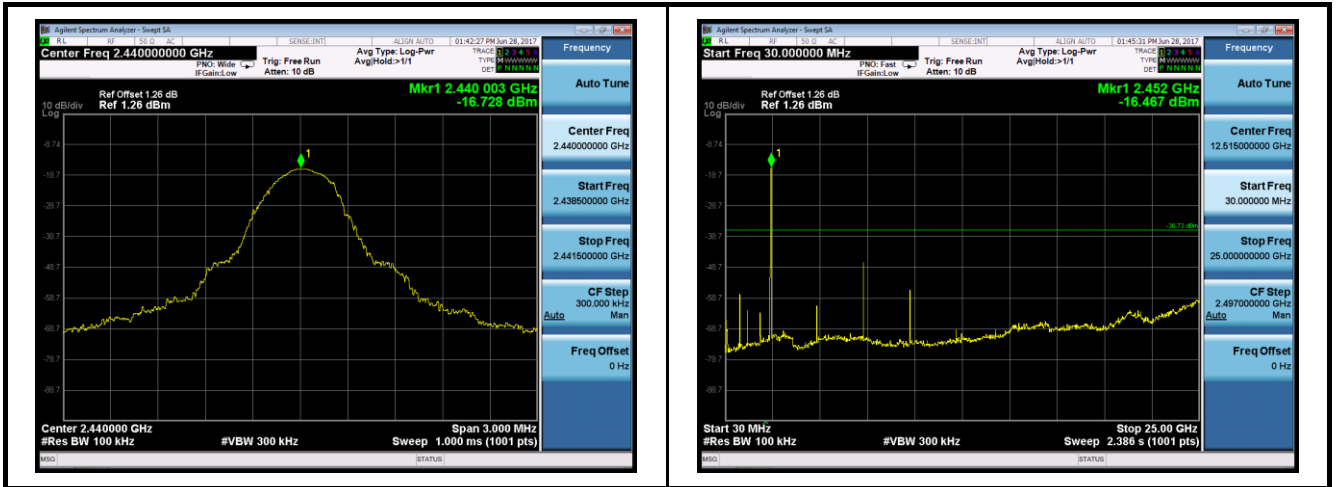

Mode 1: Transmit by BLE (2480MHz)

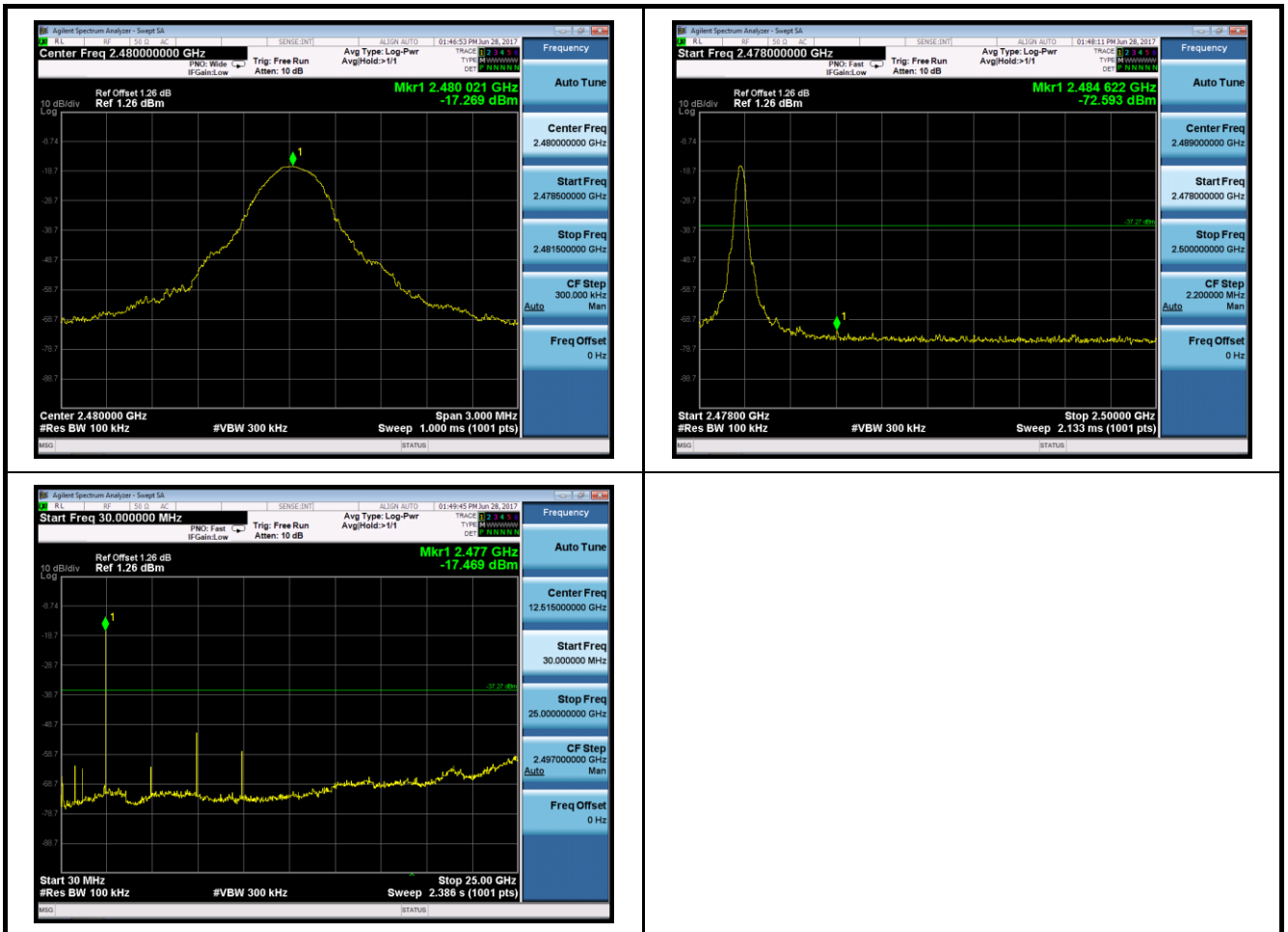



10. Radiated Emission Band Edge Measurement

10.1 Test Limit

Radiated emissions which fall in the restricted bands, as defined in Section 15.205(a) of FCC part 15, must also comply with the radiated emission limits specified in Section 15.209(a) of FCC part 15.

10.2 Test Standard

ANSI C63.10-2013 Section 6.10.5

10.3 Test Procedure

Peak Field Strength Measurements:

Analyzer center frequency was set to the frequency of the radiated spurious emission of interest

7. RBW=As specified in Table 1
8. VBW=3×RBW
9. Detector=Peak
10. Trace mode=Max hold
11. Sweep time=Auto couple
12. Allow the trace to stabilize

Table 1-RBW as a function of frequency

Frequency	RBW
9 ~ 150kHz	200 ~ 300Hz
0.15 ~ 30MHz	9 ~ 10kHz
30 ~ 1000MHz	100 ~ 120kHz
> 1000MHz	1MHz



AVE Field Strength Measurements:

Analyzer center frequency was set to the frequency of the radiated spurious emission of interest

- 7. RBW= 1MHz
- 8. VBW \geq 1/T
- 9. Detector=Peak
- 10. Trace mode=Max hold
- 11. Sweep time=Auto couple
- 12. Allow max hold to run for at least 50 times(1/duty cycle) trace

Do as an alternative, the instrument may be set to linear detector mode. Ensure that video filtering is applied in linear voltage domain (rather than in a log or dB domain). Some instruments require linear display mode in order to accomplish this. Others have a setting for Average-VBW Type, which can be set to "Voltage" regardless of the display mode

10.4 Test Setup Layout

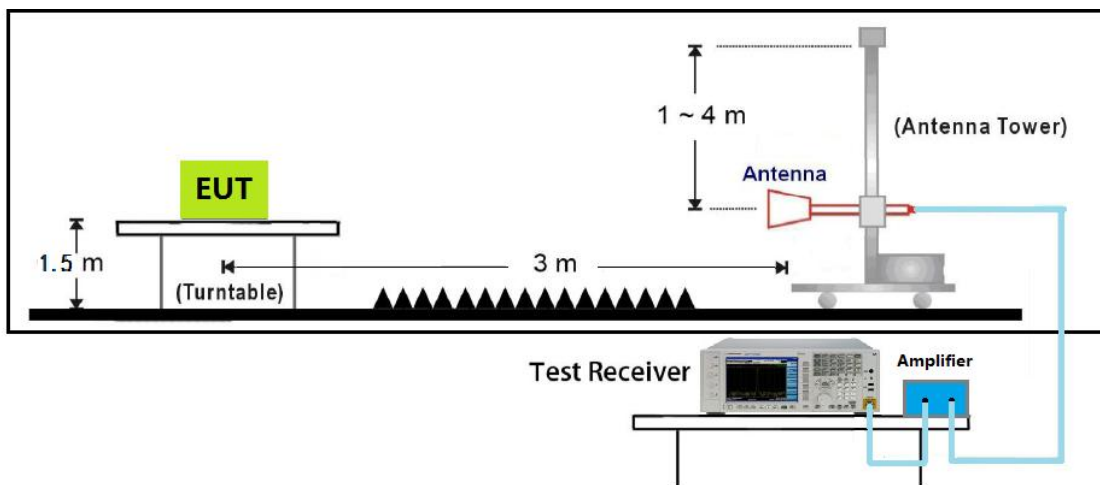



10.5 Test Result

Site: AC102	Time: 2017/06/30 - 18:05
Limit: FCC_Part15.209_RE(3m)	Margin: 0
Probe: N/A	Polarity: Horizontal
EUT: Ninebot KickScooter	Power: 120V/60Hz
Note: Mode:Transmit BLE at 2402MHz	

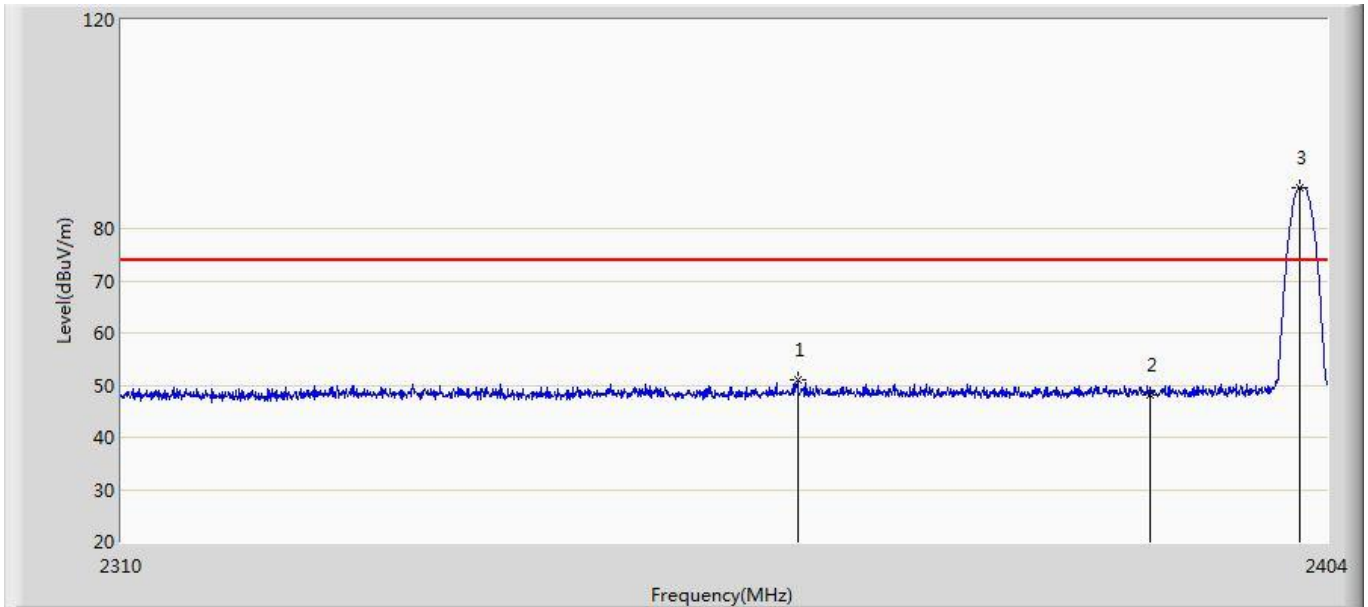

No	Mark	Frequency (MHz)	Measure Level (dBuV/m)	Reading Level (dBuV)	Over Limit (dB)	Limit (dBuV/m)	Factor (dB)	Type
1		2362.264	50.950	53.295	-23.050	74.000	-2.345	PK
2		2390.000	48.218	50.459	-25.782	74.000	-2.241	PK
3	*	2401.838	87.898	90.095	N/A	N/A	-2.197	PK

Note: Measure Level (dBμV/m) = Reading Level (dBμV) + Factor (dB)

Factor (dB) = Cable Loss (dB) + Antenna Factor (dB/m).



Site: AC102	Time: 2017/06/30 - 18:39
Limit: FCC_Part15.209_RE(3m)	Margin: 0
Probe: N/A	Polarity: Horizontal
EUT: Ninebot KickScooter	Power: 120V/60Hz
Note: Mode:Transmit BLE at 2402MHz	

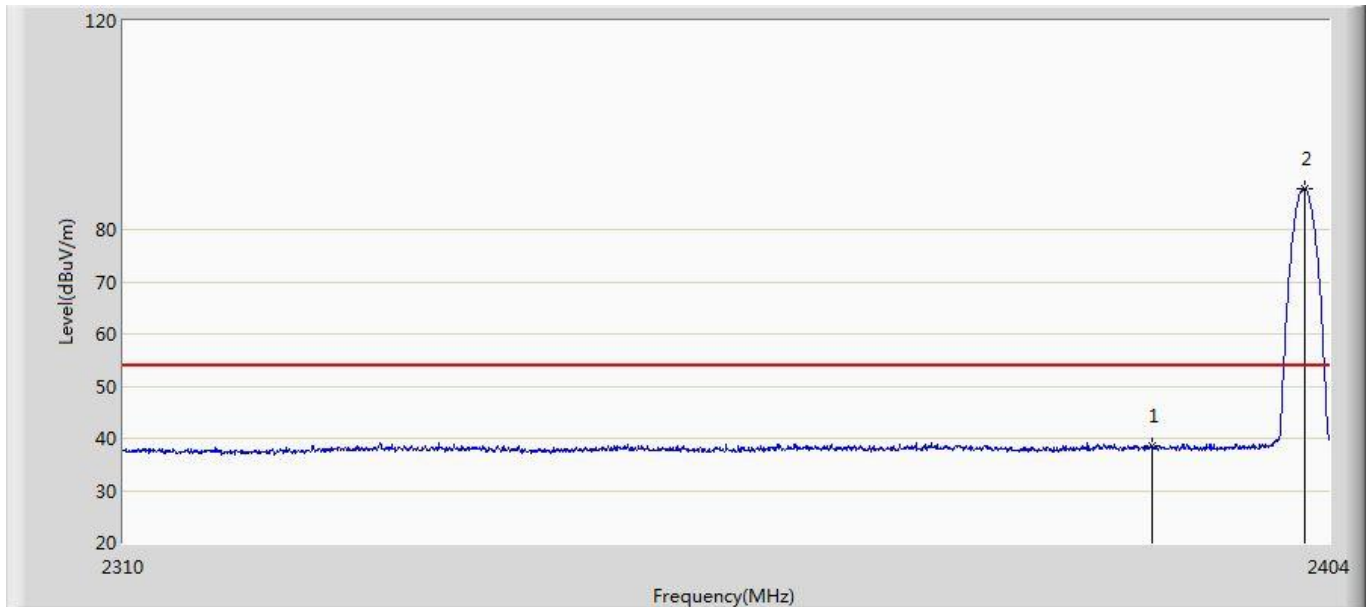

No	Mark	Frequency (MHz)	Measure Level (dBuV/m)	Reading Level (dBuV)	Over Limit (dB)	Limit (dBuV/m)	Factor (dB)	Type
1		2390.000	38.504	40.745	-15.496	54.000	-2.241	AV
2	*	2402.026	87.859	90.055	N/A	N/A	-2.196	AV

Note: Measure Level (dBμV/m) = Reading Level (dBμV) + Factor (dB)

Factor (dB) = Cable Loss (dB) + Antenna Factor (dB/m).



Site: AC102	Time: 2017/06/30 - 18:43
Limit: FCC_Part15.209_RE(3m)	Margin: 0
Probe: N/A	Polarity: Vertical
EUT: Ninebot KickScooter	Power: 120V/60Hz
Note: Mode:Transmit BLE at 2402MHz	

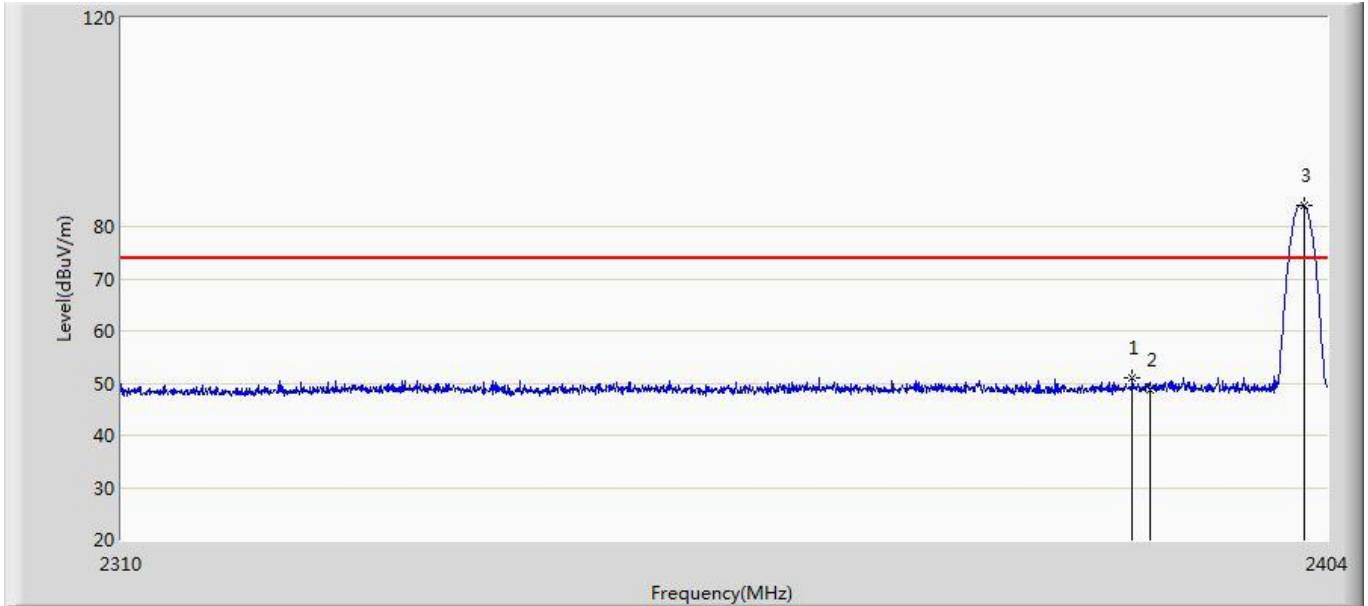

No	Mark	Frequency (MHz)	Measure Level (dBuV/m)	Reading Level (dBuV)	Over Limit (dB)	Limit (dBuV/m)	Factor (dB)	Type
1		2388.584	50.907	53.153	-23.093	74.000	-2.246	PK
2		2390.000	48.725	50.966	-25.275	74.000	-2.241	PK
3	*	2402.167	84.055	86.251	N/A	N/A	-2.196	PK

Note: Measure Level (dBμV/m) = Reading Level (dBμV) + Factor (dB)

Factor (dB) = Cable Loss (dB) + Antenna Factor (dB/m).



Site: AC102	Time: 2017/06/30 - 18:46
Limit: FCC_Part15.209_RE(3m)	Margin: 0
Probe: N/A	Polarity: Vertical
EUT: Ninebot KickScooter	Power: 120V/60Hz
Note: Mode:Transmit BLE at 2402MHz	

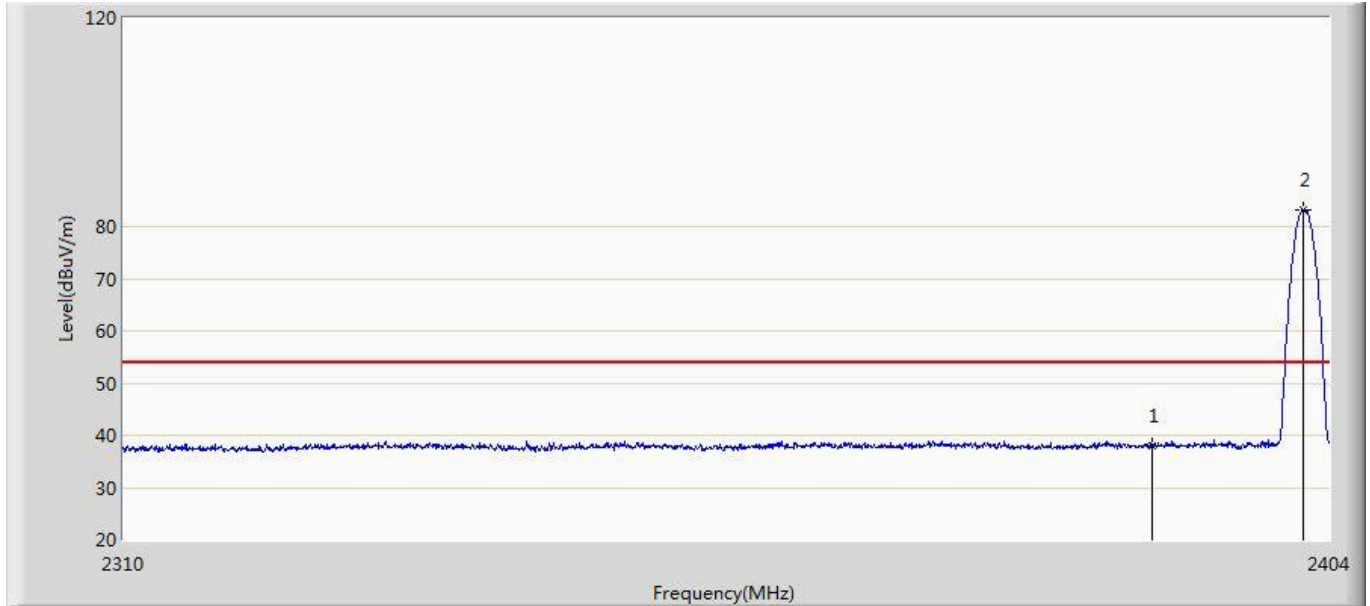

No	Mark	Frequency (MHz)	Measure Level (dBuV/m)	Reading Level (dBuV)	Over Limit (dB)	Limit (dBuV/m)	Factor (dB)	Type
1		2390.000	38.050	40.291	-15.950	54.000	-2.241	AV
2	*	2401.932	83.265	85.462	N/A	N/A	-2.197	AV

Note: Measure Level (dBμV/m) = Reading Level (dBμV) + Factor (dB)

Factor (dB) = Cable Loss (dB) + Antenna Factor (dB/m).



Site: AC102	Time: 2017/06/30 - 18:47
Limit: FCC_Part15.209_RE(3m)	Margin: 0
Probe: N/A	Polarity: Horizontal
EUT: Ninebot KickScooter	Power: 120V/60Hz
Note: Mode:Transmit BLE at 2480MHz	

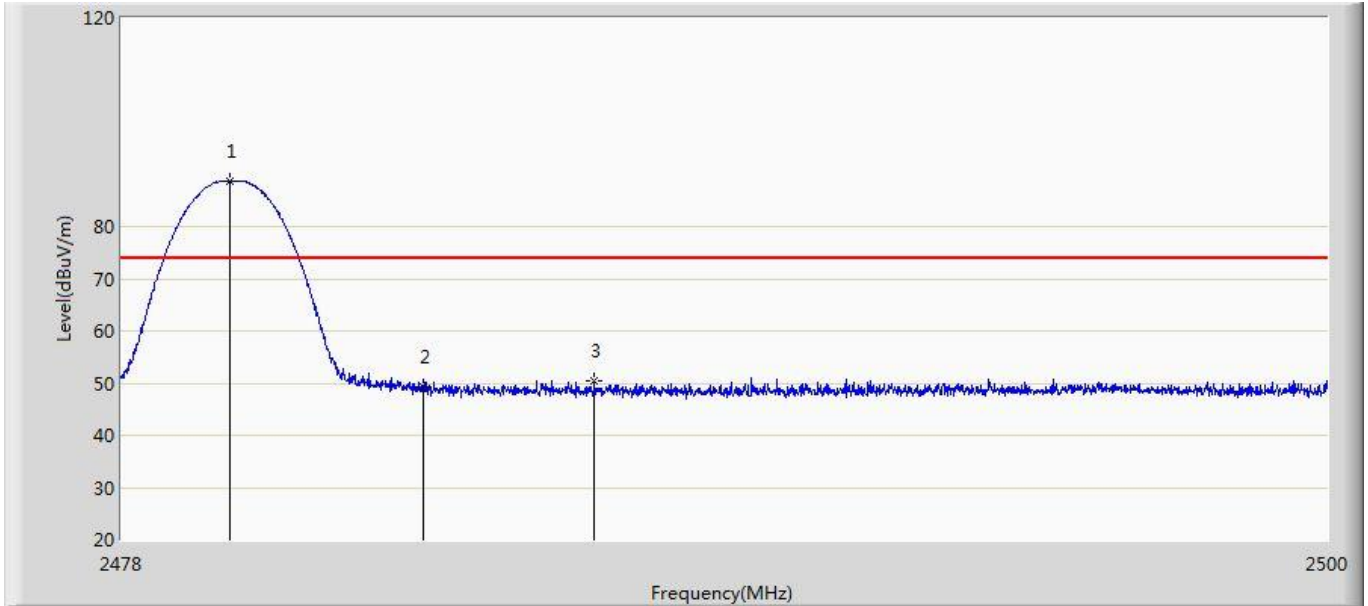

No	Mark	Frequency (MHz)	Measure Level (dBuV/m)	Reading Level (dBuV)	Over Limit (dB)	Limit (dBuV/m)	Factor (dB)	Type
1	*	2479.980	88.791	90.696	N/A	N/A	-1.905	PK
2		2483.500	49.370	51.262	-24.630	74.000	-1.892	PK
3		2486.613	50.418	52.298	-23.582	74.000	-1.880	PK

Note: Measure Level (dBμV/m) = Reading Level (dBμV) + Factor (dB)

Factor (dB) = Cable Loss (dB) + Antenna Factor (dB/m).



Site: AC102	Time: 2017/06/30 - 18:51
Limit: FCC_Part15.209_RE(3m)	Margin: 0
Probe: N/A	Polarity: Horizontal
EUT: Ninebot KickScooter	Power: 120V/60Hz
Note: Mode:Transmit BLE at 2480MHz	

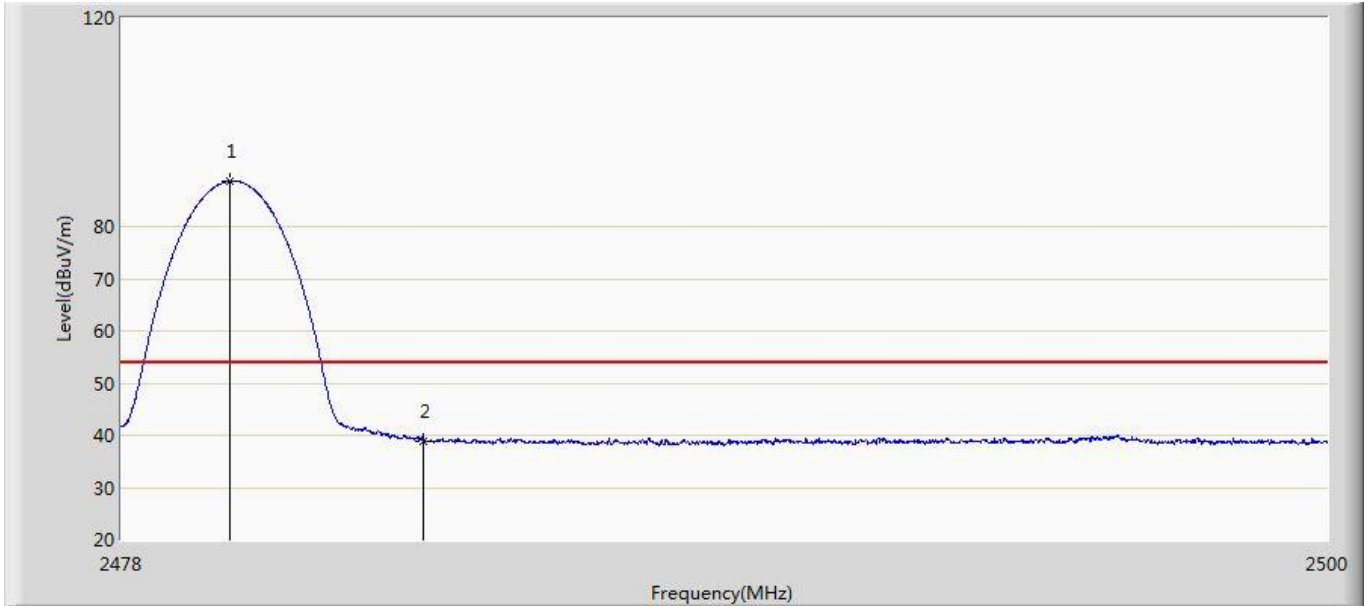

No	Mark	Frequency (MHz)	Measure Level (dBuV/m)	Reading Level (dBuV)	Over Limit (dB)	Limit (dBuV/m)	Factor (dB)	Type
1	*	2479.980	88.705	90.610	N/A	N/A	-1.905	AV
2		2483.500	38.899	40.791	-15.101	54.000	-1.892	AV

Note: Measure Level (dBμV/m) = Reading Level (dBμV) + Factor (dB)

Factor (dB) = Cable Loss (dB) + Antenna Factor (dB/m).



Site: AC102	Time: 2017/06/30- 18:52
Limit: FCC_Part15.209_RE(3m)	Margin: 0
Probe: N/A	Polarity: Vertical
EUT: Ninebot KickScooter	Power: 120V/60Hz
Note: Mode:Transmit BLE at 2480MHz	

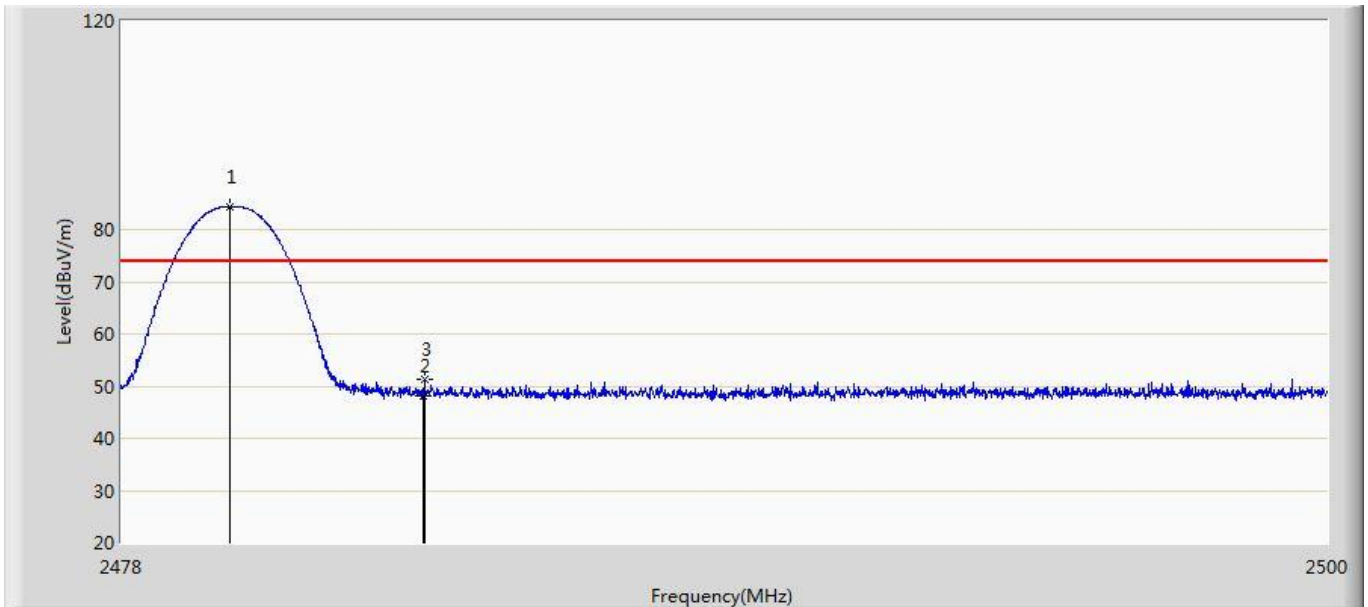

No	Mark	Frequency (MHz)	Measure Level (dBuV/m)	Reading Level (dBuV)	Over Limit (dB)	Limit (dBuV/m)	Factor (dB)	Type
1	*	2479.980	84.362	86.267	N/A	N/A	-1.905	PK
2		2483.500	48.157	50.049	-25.843	74.000	-1.892	PK
3		2483.522	51.220	53.112	-22.780	74.000	-1.892	PK

Note: Measure Level (dBμV/m) = Reading Level (dBμV) + Factor (dB)

Factor (dB) = Cable Loss (dB) + Antenna Factor (dB/m).



Site: AC102	Time: 2017/06/30 - 18:55
Limit: FCC_Part15.209_RE(3m)	Margin: 0
Probe: N/A	Polarity: Vertical
EUT: Ninebot KickScooter	Power: 120V/60Hz
Note: Mode:Transmit BLE at 2480MHz	

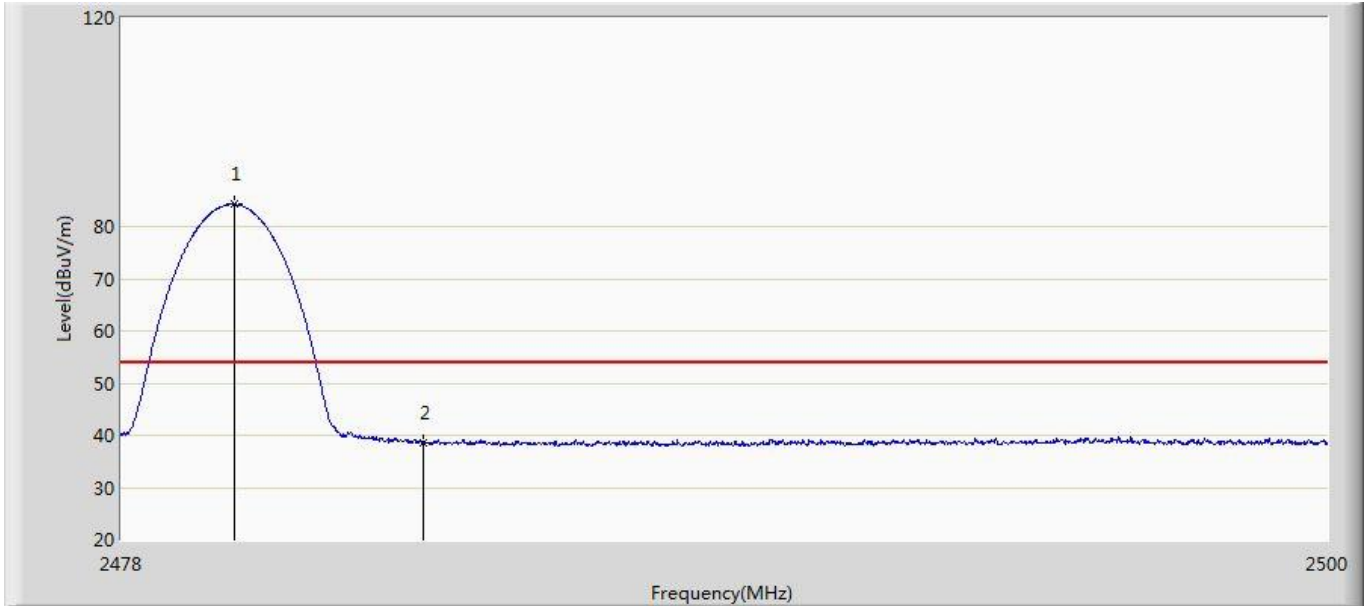

No	Mark	Frequency (MHz)	Measure Level (dBuV/m)	Reading Level (dBuV)	Over Limit (dB)	Limit (dBuV/m)	Factor (dB)	Type
1	*	2480.046	84.236	86.141	N/A	N/A	-1.905	AV
2		2483.500	38.539	40.431	-15.461	54.000	-1.892	AV

Note: Measure Level (dBμV/m) = Reading Level (dBμV) + Factor (dB)

Factor (dB) = Cable Loss (dB) + Antenna Factor (dB/m).

The End