

MEASUREMENT REPORT

FCC PART 15F & RSS-220 Issue 1

FCC ID: 2ALS8-NB5213
IC: 22636-NB5213
APPLICANT: Ninebot (Changzhou) Tech Co., Ltd.
Application Type: Certification
Product: Segway miniPLUS
Model No.: N4M350
Brand Name: SEGWAY
FCC Classification: Ultra Wideband Transmitter (UWB)
FCC Rule Part(s): Part 15F (Section 15.519)
Test Procedure(s): ANSI C63.10-2013
Test Date: August 02 ~ November 10, 2017

Reviewed By : *Sunny Sun*
(Sunny Sun)

Approved By : *Marlin Chen*
(Marlin Chen)



The test results relate only to the samples tested.

This equipment has been shown to be capable of compliance with the applicable technical standards as indicated in the measurement report and was tested in accordance with the measurement procedures specified in ANCI 63.10-2013. Test results reported herein relate only to the item(s) tested.

The test report shall not be reproduced except in full without the written approval of MRT Technology (Suzhou) Co., Ltd.

Revision History

Report No.	Version	Description	Issue Date	Note
1708RSU01401	Rev. 01	Initial Report	11-11-2017	Valid

CONTENTS

Description	Page
§2.1033 General Information	5
1. INTRODUCTION	6
1.1. Scope.....	6
1.2. MRT Test Location	6
2. PRODUCT INFORMATION	7
2.1. Feature of Equipment under Test	7
2.2. Feature of UWB Technology	7
2.3. Test Mode	7
2.4. Description of Test Software.....	7
2.5. Device Capabilities	7
2.6. Test Configuration	8
2.7. EMI Suppression Device(s)/Modifications.....	8
2.8. Labeling Requirements.....	8
2.9. Cross Reference	8
2.10. Marketing of UWB Equipment	9
2.11. Technical requirements applicable to all UWB devices.....	9
3. DESCRIPTION of TEST	10
3.1. Evaluation Procedure	10
3.2. AC Line Conducted Emissions	10
3.3. Radiated Emissions.....	11
4. ANTENNA REQUIREMENTS	12
5. TEST EQUIPMENT CALIBRATION DATE	13
6. MEASUREMENT UNCERTAINTY	14
7. TEST RESULT	15
7.1. Summary.....	15
7.2. Occupied Bandwidth Measurement	16
7.2.1. Test Limit	16
7.2.2. Test Procedure used.....	16
7.2.3. Test Setting.....	16
7.2.4. Test Setup	17
7.2.5. Test Result.....	18
7.3. Radiated Power Density and Peak Power within 50 MHz bandwidth	19
7.3.1. Test Limit	19

7.3.2.	Test Procedure Used	19
7.3.3.	Test Setting.....	20
7.3.4.	Test Setup	21
7.3.5.	Test Result.....	22
7.4.	Radiated spurious emission measurements	27
7.4.1.	Test Limit	27
7.4.2.	Test Procedure Used	28
7.4.3.	Test Setting.....	28
7.4.4.	Test Setup	28
7.4.5.	Test Result.....	31
7.5.	Transmission Duration Requirements.....	51
7.5.1.	Test Limit	51
7.5.2.	Test Procedure Used	51
7.5.3.	Test Setting.....	51
7.5.4.	Test Setup	51
7.5.5.	Test Result.....	52
7.6.	AC Conducted Emissions Measurement	53
7.6.1.	Test Limit	53
7.6.2.	Test Procedure Used	53
7.6.3.	Test Setting.....	53
7.6.4.	Test Setup	54
7.6.5.	Test Result.....	55
8.	CONCLUSION	57

§2.1033 General Information

Applicant:	Ninebot (Changzhou) Tech Co., Ltd.
Applicant Address:	16F-17F, Block A, Building 3, Changwu Mid Road 18#, Wujin Dist., Changzhou, Jiangsu, China.
Manufacturer:	Ninebot (Changzhou) Tech Co., Ltd.
Manufacturer Address:	16F-17F, Block A, Building 3, Changwu Mid Road 18#, Wujin Dist., Changzhou, Jiangsu, China.
Test Site:	MRT Technology (Suzhou) Co., Ltd
Test Site Address:	D8 Building, No.2 Tian'edang Rd., Wuzhong Economic Development Zone, Suzhou, China
MRT FCC Registration No.:	893164
MRT IC Registration No.:	11384A-1
FCC Rule Part(s):	FCC CFR 47 Part 15 subpart F, section 15.519
IC Rules:	RSS-220 issue 1
Test Device Serial No.:	N/A <input type="checkbox"/> Production <input checked="" type="checkbox"/> Pre-Production <input type="checkbox"/> Engineering

Test Facility / Accreditations

Measurements were performed at MRT Laboratory located in Tian'edang Rd., Suzhou, China.

- MRT facility is a FCC registered (MRT Reg. No. 893164) test facility with the site description report on file and has met all the requirements specified in Section 2.948 of the FCC Rules.
- MRT facility is an IC registered (MRT Reg. No. 11384A-1) test laboratory with the site description on file at Industry Canada.
- MRT facility is a VCCI registered (R-4179, G-814, C-4664, T-2206) test laboratory with the site description on file at VCCI Council.
- MRT Lab is accredited to ISO 17025 by the American Association for Laboratory Accreditation (A2LA) under the American Association for Laboratory Accreditation Program (A2LA Cert. No. 3628.01) in EMC, Telecommunications and Radio testing for FCC, Industry Canada, EU and TELEC Rules.



1. INTRODUCTION

1.1. Scope

Measurement and determination of electromagnetic emissions (EMC) of radio frequency devices including intentional and/or unintentional radiators for compliance with the technical rules and regulations of the Federal Communications Commission and the Industry Canada Certification and Engineering Bureau.

1.2. MRT Test Location

The map below shows the location of the MRT LABORATORY, its proximity to the Taihu Lake. These measurement tests were conducted at the MRT Technology (Suzhou) Co., Ltd. Facility located at D8 Building, No.2 Tian'edang Rd., Wuzhong Economic Development Zone, Suzhou, China. The detailed description of the measurement facility was found to be in compliance with the requirements of § 2.948 according to ANSI C63.4-2009 on September 30, 2013.



2. PRODUCT INFORMATION

2.1. Feature of Equipment under Test

Product Name:	Segway miniPLUS
Model No.:	N4M350
Brand Name:	SEGWAY
RF Function:	Bluetooth v4.1 (BLE Only), UWB
Operation Frequency:	Bluetooth: 2402 ~ 2480MHz, UWB: 6489.6 MHz
Antenna Type:	Bluetooth Antenna: PCB Antenna, UWB Antenna: Anchor Antenna
Antenna Gain:	Bluetooth Antenna: 5dBi UWB Antenna: 9.95dBi
UWB Power Setting:	13.5

2.2. Feature of UWB Technology

EUT Classification:	Hand Held UWB Systems
General Overview:	<p>This Remote Controller is a Hand Held UWB device, ie., according to FCC definition: As used in this subpart, a hand held device is a portable device, such as a lap top computer or a PDA, that is primarily hand held while being operated and that does not employ a fixed infrastructure.</p> <p>This Remote Controller product include:</p> <ul style="list-style-type: none"> ● One couple of transmitting and receiving tag antenna. ● The control unit that is link to an associated receiver

2.3. Test Mode

Test Mode	Mode 1: Transmit by UWB
-----------	-------------------------

2.4. Description of Test Software

N/A

2.5. Device Capabilities

This device contains the following capabilities:

UWB & Bluetooth Device.

2.6. Test Configuration

The **Segway miniPLUS** was tested per the guidance of ANSI C63.10-2013.

2.7. EMI Suppression Device(s)/Modifications

No EMI suppression device(s) were added and/or no modifications were made during testing.

2.8. Labeling Requirements

Per 2.1074 & 15.19; Docket 95-19

The label shall be permanently affixed at a conspicuous location on the device; instruction manual or pamphlet supplied to the user and be readily visible to the purchaser at the time of purchase. However, when the device is so small wherein placement of the label with specified statement is not practical, only the FCC ID must be displayed on the device per Section 15.19(a)(5). Please see attachment for FCC ID label and label location.

2.9. Cross Reference

Per FCC 15.505

- a. Except where specifically stated otherwise within this subpart, the provisions of subparts A and B and of §§15.201 through 15.204 and 15.207 of subpart C of this part apply to unlicensed UWB intentional radiators. The provisions of §15.35(c) and 15.205 do not apply to devices operated under this subpart. The provisions of Footnote US 246 to the Table of Frequency Allocations contained in §2.106 of this chapter does not apply to devices operated under this subpart.
- b. The requirements of this subpart apply only to the radio transmitter, i.e., the intentional radiator, contained in the UWB device. Other aspects of the operation of a UWB device may be subject to requirements contained elsewhere in this chapter. In particular, a UWB device that contains digital circuitry not directly associated with the operation of the transmitter also is subject to the requirements for unintentional radiators in subpart B of this part. Similarly, an associated receiver that operates (tunes) within the frequency range 30 MHz to 960 MHz is subject to the requirements in subpart B of this part.

The **Segway miniPLUS** under test complies with all the relevant and applicable requirements of Subpart A, Subpart B and Section 15.201 through 15.204 and Section 15.207 of Subpart C. And the digital circuitry portion of the EUT has been tested and verified to comply with 47 CFR Part 15, subpart B.

2.10. Marketing of UWB Equipment

In some cases, the operation of UWB devices is limited to specific parties, e.g., law enforcement, fire and rescue organizations operating under the auspices of a state or local government. The marketing of UWB devices must be directed solely to parties eligible to operate the equipment. The responsible party, as defined in §2.909 of this chapter, is responsible for ensuring that the equipment is marketed only to eligible parties. Marketing of the equipment in any other manner may be considered grounds for revocation of the grant of certification issued for the equipment.

The responsible part is properly informed about the responsible for ensuring that the equipment is marketed only to eligible parties, and provide correct information on the customers and users. See “Federal Communications Commission (FCC) Compliance Statement for USA” of the device user manual.

2.11. Technical requirements applicable to all UWB devices

Requirement	Description	Conclusion
§15.521(a)	The EUT is not employed for the operation of toys, operation onboard an aircraft, ship and satellite.	Comply
§15.521(b)	Permanent attached antenna, no External radio frequency power amplifiers and antenna modifications are permitted.	Comply
§15.521(c)	The Digital circuitry portion of the EUT has been tested and verified to comply with 47 CFR Part 15, subpart B.	Comply
§15.521(d)	Considered	Comply
§15.521(e)	The f_m , frequency at which the highest radiated emission occurs is contained within the measured UWB bandwidth.	Comply
§15.521(f)	The EUT is not intended to detection of tags or the transfer or data or voice information.	Comply
§15.521(g)	Considered	Comply
§15.521(h)	Considered	Comply
§15.521(i)	Prohibition in Sections 2.201(f) and 15.5(d) of this chapter against Class B (damped wave) emissions is not applied.	Comply
§15.521(j)	Responsible parties are reminded of the other standards and requirements cross referenced in §15.505, such as a limit on emissions conducted onto the AC power lines.	Comply

3. DESCRIPTION of TEST

3.1. Evaluation Procedure

The measurement procedures described in the American National Standard for Procedures for measuring ultra-wideband devices (ANSI C63.10-2013).

Deviation from measurement procedure.....None

3.2. AC Line Conducted Emissions

The line-conducted facility is located inside an 8'x4'x4' shielded enclosure. A 1m x 2m wooden table 80cm high is placed 40cm away from the vertical wall and 80cm away from the sidewall of the shielded room. Two 10kHz-30MHz, 50Ω/50uH Line-Impedance Stabilization Networks (LISNs) are bonded to the shielded room floor. Power to the LISNs is filtered by external high-current high-insertion loss power line filters. These filters attenuate ambient signal noise from entering the measurement lines. These filters are also bonded to the shielded enclosure.

The EUT is powered from one LISN and the support equipment is powered from the second LISN. All interconnecting cables more than 1 meter were shortened to a 1 meter length by non-inductive bundling (serpentine fashion) and draped over the back edge of the test table. All cables were at least 40cm above the horizontal reference ground-plane. Power cables for support equipment were routed down to the second LISN while ensuring that that cables were not draped over the second LISN.

Sufficient time for the EUT, support equipment, and test equipment was allowed in order for them to warm up to their normal operating condition. The RF output of the LISN was connected to the receiver and exploratory measurements were made to determine the frequencies producing the maximum emission from the EUT. The receiver was scanned from 150kHz to 30MHz. The detector function was set to peak mode for exploratory measurements while the bandwidth of the analyzer was set to 9kHz. The EUT, support equipment, and interconnecting cables were arranged and manipulated to maximize each emission. Each emission was also maximized by varying: power lines, the mode of operation or data exchange speed, or support equipment whichever determined the worst-case emission. Once the worst case emissions have been identified, the one EUT cable configuration/arrangement and mode of operation that produced these emissions were used for final measurements on the same test site. The analyzer is set to CISPR quasi-peak and average detectors with a 9kHz resolution bandwidth for final measurements.

An extension cord was used to connect to a single LISN which powered by EUT. The extension cord was calibrated with LISN, the impedance and insertion loss are compliance with the requirements as stated in ANSI C63.10-2013.

3.3. Radiated Emissions

The radiated test facilities consisted of an indoor 3 meter semi-anechoic chamber used for final measurements and exploratory measurements, when necessary. The measurement area is contained within the semi-anechoic chamber which is shielded from any ambient interference. For measurements above 1GHz absorbers are arranged on the floor between the turn table and the antenna mast in such a way so as to maximize the reduction of reflections. For measurements below 1GHz, the absorbers are removed. A MF Model 210SS turntable is used for radiated measurement. It is a continuously rotatable, remote controlled, metallic turntable and 2 meters (6.56 ft.) in diameter. The turn table is flush with the raised floor of the chamber in order to maintain its function as a ground plane. An 80cm high PVC support structure is placed on top of the turntable.

For all measurements, the spectrum was scanned through all EUT azimuths and from 1 to 4 meter receive antenna height using a broadband antenna from 30MHz up to the upper frequency shown in 15.33(b)(1) depending on the highest frequency generated or used in the device or on which the device operates or tunes. For frequencies above 1GHz, linearly polarized double ridge horn antennas were used. For frequencies below 30MHz, a calibrated loop antenna was used. When exploratory measurements were necessary, they were performed at 1 meter test distance inside the semi-anechoic chamber using broadband antennas, broadband amplifiers, and spectrum analyzers to determine the frequencies and modes producing the maximum emissions. Sufficient time for the EUT, support equipment, and test equipment was allowed in order for them to warm up to their normal operating condition. The test set-up for frequencies below 1GHz was placed on top of the 0.8 meter high, 1 x 1.5 meter table; and test set-up for frequencies 1-40GHz was placed on top of the 1.5 meter high, 1 x 1.5 meter table. The EUT, support equipment, and interconnecting cables were arranged and manipulated to maximize each emission. Appropriate precaution was taken to ensure that all emissions from the EUT were maximized and investigated. The system configuration, clock speed, mode of operation or video resolution, if applicable, turntable azimuth, and receive antenna height was noted for each frequency found.

Final measurements were made in the semi-anechoic chamber using calibrated, linearly polarized broadband and horn antennas. The test setup was configured to the setup that produced the worst case emissions. The spectrum analyzer was set to investigate all frequencies required for testing to compare the highest radiated disturbances with respect to the specified limits. The turntable containing the EUT was rotated through 360 degrees and the height of the receive antenna was varied 1 to 4 meters and stopped at the azimuth and height producing the maximum emission. Each emission was maximized by changing the orientation of the EUT through three orthogonal planes and changing the polarity of the receive antenna, whichever produced the worst-case emissions. According to 3dB Beam-Width of horn antenna, the horn antenna should be always directed to the EUT when rising height.

4. ANTENNA REQUIREMENTS

Excerpt from §15.203 of the FCC Rules/Regulations:

“An intentional radiator antenna shall be designed to ensure that no antenna other than that furnished by the responsible party can be used with the device. The use of a permanently attached antenna or of an antenna that uses a unique coupling to the intentional radiator shall be considered sufficient to comply with the provisions of this section.”

- The antenna of the **Segway miniPLUS** is **permanently attached**.
- There are no provisions for connection to an external antenna.

Conclusion:

The **Segway miniPLUS** unit complies with the requirement of §15.203.

5. TEST EQUIPMENT CALIBRATION DATE

Radiated Disturbance - AC1

Instrument	Manufacturer	Type No.	Asset No.	Cali. Interval	Cali. Due Date
MXE EMI Receiver	Agilent	N9038A	MRTSUE06125	1 year	2018/08/17
Loop Antenna	Schwarzbeck	FMZB1519	MRTSUE06025	1 year	2017/12/21
Bilog Period Antenna	Schwarzbeck	VULB9162	MRTSUE06022	1 year	2018/10/21
Broad-Band Horn Antenna	Schwarzbeck	BBHA9120D	MRTSUE06171	1 year	2017/11/19
Broadband Coaxial Preamplifier	Schwarzbeck	BBV 9718	MRTSUE06106	1 year	2017/12/10
Broadband Horn Antenna	Schwarzbeck	BBHA9170	MRTSUE06024	1 year	2018/04/25
Digital Thermometer & Hygrometer	Minggao	ETH529	MRTSUE06170	1 year	2017/11/30
Anechoic Chamber	RIKEN	Chamber-AC1	MRTSUE06213	1 year	2018/05/10

Conducted Test Equipment - TR3

Instrument	Manufacturer	Type No.	Asset No.	Cali. Interval	Cali. Due Date
Spectrum Analyzer	Agilent	N9020A	MRTSUE06106	1 year	2018/04/25
MXE EMI Receiver	Keysight	N9038A	MRTSUE06125	1 year	2018/08/17
Signal Analyzer	R&S	FSV40	MRTSUE06218	1 year	2018/03/27
Temperature/Humidity Meter	Yuhuaze	HTC-2	MRTSUE06184	1 year	2017/12/22

Software	Version	Function
e3	V8.3.5	EMI Test Software

6. MEASUREMENT UNCERTAINTY

Where relevant, the following test uncertainty levels have been estimated for tests performed on the EUT as specified in CISPR 16-4-2. This uncertainty represents an expanded uncertainty expressed at approximately the 95% confidence level using a coverage factor of $k = 2$.

AC Conducted Emission Measurement - SR2
Measuring Uncertainty for a Level of Confidence of 95% ($U=2Uc(y)$): 150kHz~30MHz: 3.46dB
Radiated Emission Measurement - AC1
Measuring Uncertainty for a Level of Confidence of 95% ($U=2Uc(y)$): 9kHz ~ 1GHz: ± 4.18 dB 1GHz ~ 40GHz: ± 4.76 dB

7. TEST RESULT

7.1. Summary

Product Name: Segway miniPLUS
FCC ID: 2ALS8-NB5213
IC: 22636-NB5213
FCC Classification: Ultra Wideband Transmitter (UWB)

FCC Section(s)	IC Section(s)	Test Description	Test Limit	Test Condition	Test Result	Reference
FCC Section 15.519(b)	RSS-220 Issue 1, Section 2	Occupied Bandwidth	$\geq 500\text{MHz}$	Conducted	Pass	Section 7.2
FCC Section 15.519(c)	RSS-220 Issue 1, Section 5.3.1(d)	Radiated Power Density	Refer to Section 7.3	Radiated	Pass	Section 7.3
FCC Section 15.519(c)	RSS-220 Issue 1, Section 5.3.1(c)	Radiated Spurious Emissions below 960 MHz	Refer to Section 7.4		Pass	Section 7.4
FCC Section 15.519(c), (d)	RSS-220 Issue 1, Section 5.3.1(d) (e)	Radiated Spurious Emissions above 960 MHz	Refer to Section 7.4		Pass	Section 7.4
FCC Section 15.519(e),	RSS-220 Issue 1, Section 5.3.1(g)	Peak Power within 50 MHz Bandwidth	Refer to Section 7.4		Pass	Section 7.4
FCC Section 15.519(a)(1),	RSS-220 section 5.3.1(b),	Transmission duration requirements	Refer to Section 7.5		Conducted	Pass
FCC Section 15.207	RSS-GEN Issue section 8.8	AC Conducted Emission	Refer to Section 7.6	Conducted	Pass	Section 7.6

Notes:

The analyzer plots shown in this section were all taken with a correction table loaded into the analyzer. The correction table was used to account for the losses of the cables and attenuators used as part of the system to connect the EUT to the analyzer at all frequencies of interest.

7.2. Occupied Bandwidth Measurement

7.2.1. Test Limit

A UWB device is an intentional radiator that has either a -10dB bandwidth of at least 500 MHz or a -10 dB fractional bandwidth greater than 0.2. There are eight distinct subclasses of UWB device.

7.2.2. Test Procedure used

ANSI C63.10-2013, section 10.1

7.2.3. Test Setting

The frequency at which the maximum power level is measured with the peak detector is designated f_M . The peak power measurements shall be made using a spectrum analyzer or EMI receiver with a 1 MHz resolution bandwidth and a video bandwidth of 1 MHz or greater. The instrument shall be set to peak detection using the maximum-hold trace mode. The outermost 1 MHz segments above and below f_M , where the peak power falls by 10 dB relative to the level at f_M , are designated as f_H and f_L , respectively:

- a) For the lowest frequency bound f_L , the emission is searched from a frequency lower than f_M that has, by inspection, a peak power much lower than 10 dB less than the power at f_M and increased toward f_M until the peak power indicates 10 dB less than the power at f_M . The frequency of that segment is recorded.
- b) This process is repeated for the highest frequency bound f_H , beginning at a frequency higher than f_M that has, by inspection, a peak power much lower than 10 dB below the power at f_M . The frequency of that segment is recorded.
- c) The two recorded frequencies represent the highest f_H and lowest f_L bounds of the UWB transmission, and the -10 dB bandwidth ($B - 10$) is defined as $(f_H - f_L)$. The center frequency (f_c) is mathematically determined from $(f_H + f_L) / 2$.
- d) The fractional bandwidth is defined as $2(f_H - f_L) / (f_H + f_L)$.
- e) Determine whether the -10 dB bandwidth $(f_H - f_L)$ is ≥ 500 MHz, or whether the fractional bandwidth $2(f_H - f_L) / (f_H + f_L)$ is ≥ 0.2 .

7.2.4. Test Setup

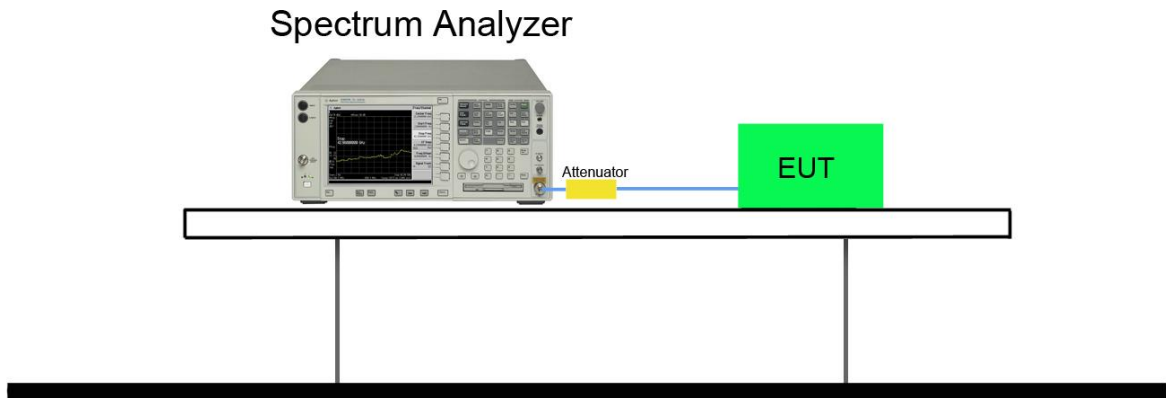

7.2.5. Test Result

Product	Segway miniPLUS	Temperature	25°C
Test Engineer	Roy Cheng	Relative Humidity	60%
Test Site	TR3	Test Date	2017/08/06
Test Item	-10dB Occupied Bandwidth		

Frequency (MHz)	-10dB Bandwidth (MHz)	Limit (MHz)	Result
6489.6	613.05	≥ 500	Pass

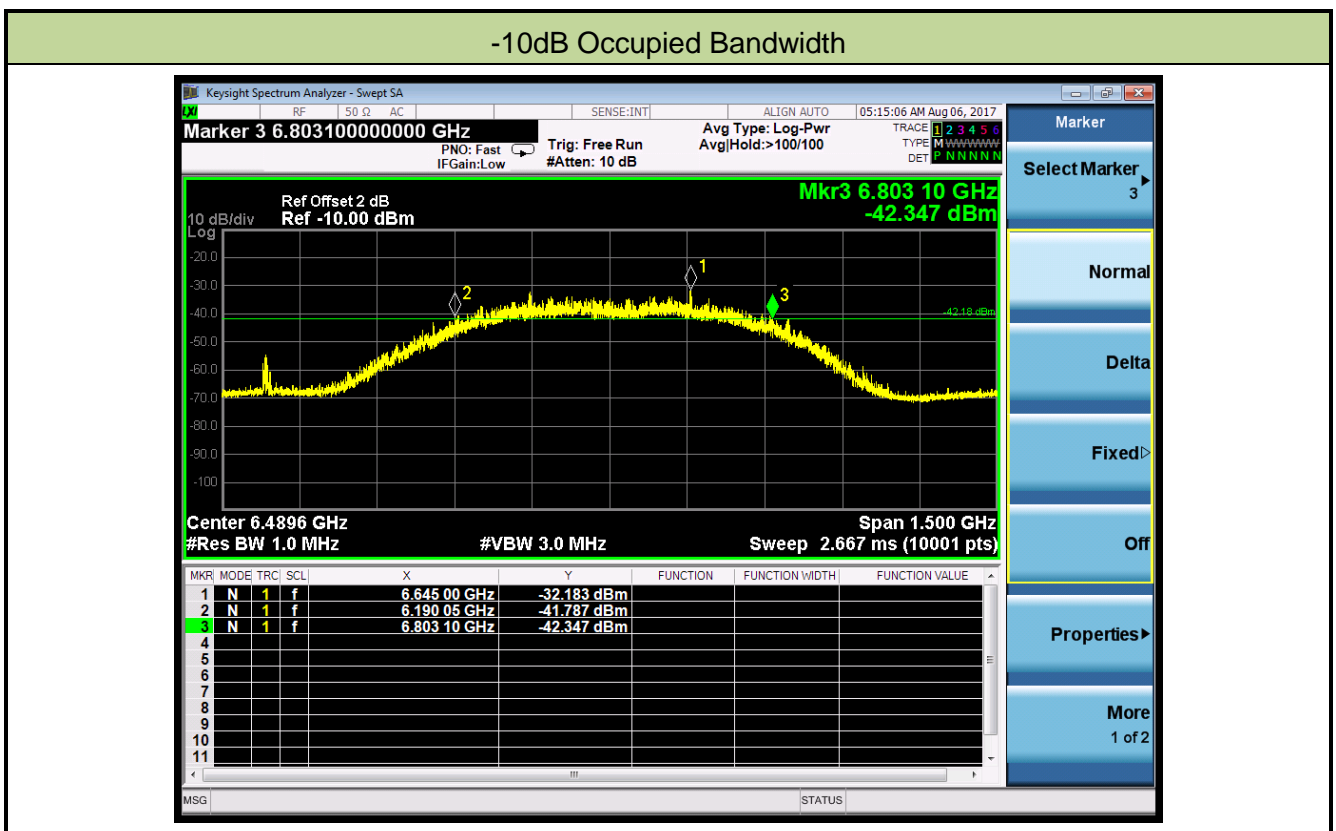

7.3. Radiated Power Density and Peak Power within 50 MHz bandwidth

7.3.1. Test Limit

This test was performed to measure effective radiated power emanated by transmitter at carrier frequency. Specification test limits are given in the following table.

Power spectral density limit (EIRP)

Assigned frequency band (MHz)	EIRP in dBm	Equivalent field strength limit in MHz @ 1m (dB μ v/m)
FCC section 15.519(c)		
3100 - 10600	-41.3	63.44
RSS-220 section 5.3.1(d)		
4750 - 10600	-41.3	63.44

Peak power limit (EIRP)

Assigned frequency band (MHz)	EIRP in 50MHz BW (dBm)	Equivalent field strength limit in MHz @ 1m (dB μ v/m)
FCC section 15.519(c)		
3100 - 10600	0	70.74

Note 1: Because the limits are so low, some bands may have been scanned at a distance closer than 1 meter. If any emissions were detected in these bands, final measurements were made at distance of 1 meter or greater. The actual distance for final measurement was indicated in the measurement data.

Note 2: Power spectral density limit at 1m = $-41.3\text{dBm/MHz} + 95.2 + 20 \cdot \log(3\text{m}/1\text{m}) = 63.44\text{dB}\mu\text{v/m}$

Note 3: Peak power limit at 1m = $0\text{dBm} + 20 \cdot \log(1\text{MHz}/50\text{MHz}) + 95.2 + 20 \cdot \log(3\text{m}/1\text{m}) = 70.74\text{dB}\mu\text{v/m}$

7.3.2. Test Procedure Used

ANSI C63.10-2013, Section 10.3

7.3.3. Test Setting

Bandwidth conversion of peak power measurements

It is acceptable to employ an RBW of less than 50 MHz (but no less than 1 MHz) when performing the required peak power measurements. When this approach is employed, the peak emissions EIRP limit (0 dBm / 50 MHz) is converted to a limit commensurate with the RBW by employing a $[20 \log (RBW/50 \text{ MHz})]$ relationship. For example, the peak power limit could be expressed in a 1 MHz bandwidth as follows in Equation:

$$EIRP_{1\text{MHz}} = EIRP_{50\text{MHz}} + 20\log(1\text{MHz}/50\text{MHz}) = 0\text{dBm} + (-34\text{dB}) = -34\text{dBm}$$

When a resolution bandwidth of less than 50 MHz is used, this measurement shall be performed over a 50 MHz span centered on the frequency associated with the highest detected average emission level.

Evaluating rms-average power spectral density

The following procedure shall be used for evaluating rms-average power spectral density:

- a) Set the RBW to 1MHz.
- b) Set the VBW to be at least 1MHz (a VBW of 3 MHz is desirable).
- c) Set the frequency span to examine the spectrum across a convenient frequency segment (e.g. 600 MHz).
- d) Select the power averaging (rms) detector.
- e) Set the sweep time so that there is no more than a 1 ms integration period over each measurement bin.

7.3.4. Test Setup

1GHz ~ 40GHz Test Setup:

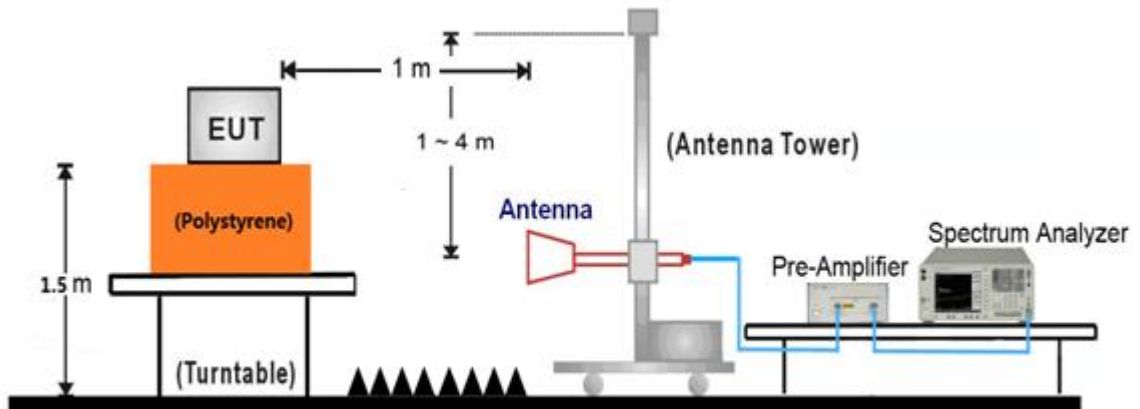

7.3.5. Test Result

Power Spectral Density Test Result Summary

Frequency (MHz)	Equivalent field strength dB μ v/m(MHz)	Limit dB μ v/m(MHz)	Margin (dB)	Polarity	Verdict
6334.25	59.82	63.44	-3.62	Horizontal	Pass
6490.25	55.38	63.44	-8.06	Vertical	Pass

Peak Power within 50MHz BW Test Result Summary

Frequency (MHz)	Equivalent field strength dB μ v/m(MHz)	Limit dB μ v/m(MHz)	Margin (dB)	Polarity	Verdict
6335.10	62.84	70.74	-7.90	Horizontal	Pass
6489.63	57.12	70.74	-13.62	Vertical	Pass

Note 1: The Margin = Equivalent field strength - Limit.

Note 2: The detail test plots have been showed as below.

Site: AC1	Time: 2017/08/07 - 18:31
Limit: FCC_Part 15.519(c)_(1m)	Engineer: Will Yan
Probe: BBHA9120D_1-18GHz	Polarity: Horizontal
EUT: Segway miniPLUS	Power: By Battery

Note: Evaluating rms-average power spectral density

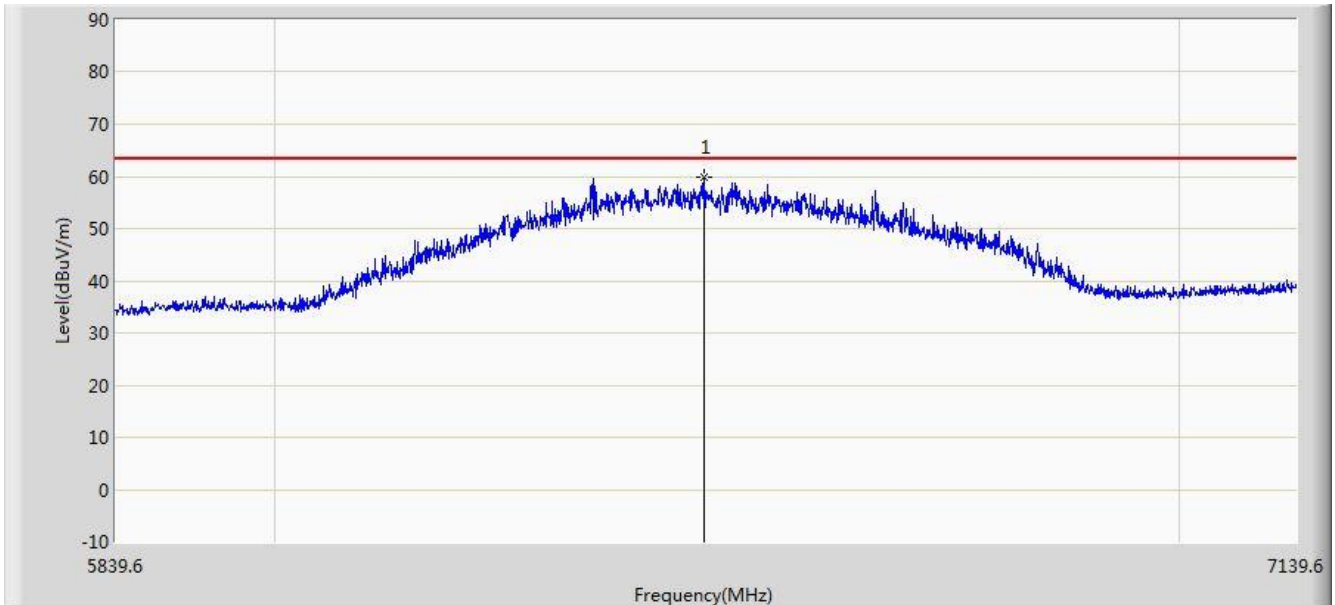

No	Flag	Mark	Frequency (MHz)	Measure Level (dBuV/m)	Reading Level (dBuV)	Over Limit (dB)	Limit (dBuV/m)	Factor	Type
1		*	6455.150	59.815	54.055	-3.625	63.440	5.760	AV

Note: Measure Level (dB μ V/m) = Reading Level (dB μ V) + Factor (dB)

Factor (dB) = Cable Loss (dB) + Antenna Factor (dB/m) - Pre_Amplifier Gain (dB).

Site: AC1	Time: 2017/08/07 - 18:44
Limit: FCC_Part 15.519(e)_(1m)	Engineer: Will Yan
Probe: BBHA9120D_1-18GHz	Polarity: Horizontal
EUT: Segway miniPLUS	Power: By Battery

Note: Bandwidth conversion of peak power measurements

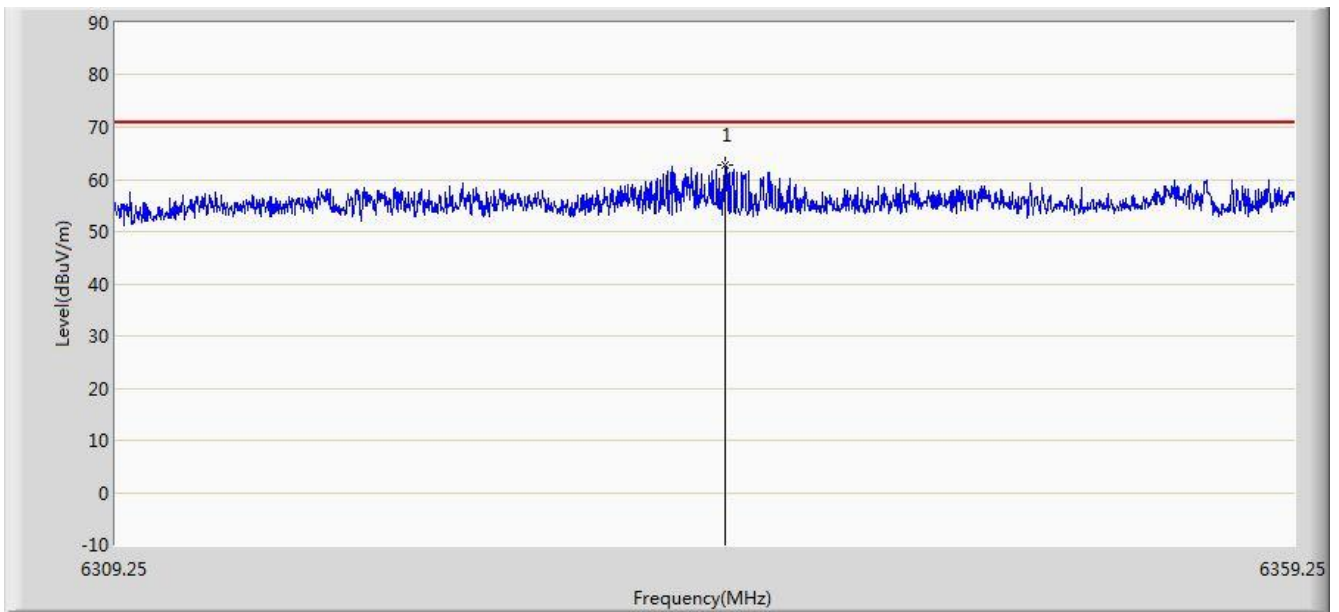

No	Flag	Mark	Frequency (MHz)	Measure Level (dBuV/m)	Reading Level (dBuV)	Over Limit (dB)	Limit (dBuV/m)	Factor	Type
1		*	6335.100	62.842	57.791	-7.898	70.740	5.051	PK

Note: Measure Level (dB μ V/m) = Reading Level (dB μ V) + Factor (dB)

Factor (dB) = Cable Loss (dB) + Antenna Factor (dB/m) - Pre_Amplifier Gain (dB).

Site: AC1	Time: 2017/08/07 - 18:47
Limit: FCC_Part 15.519(c)_(1m)	Engineer: Will Yan
Probe: BBHA9120D_1-18GHz	Polarity: Vertical
EUT: Segway miniPLUS	Power: By Battery
Note: Evaluating rms-average power spectral density	

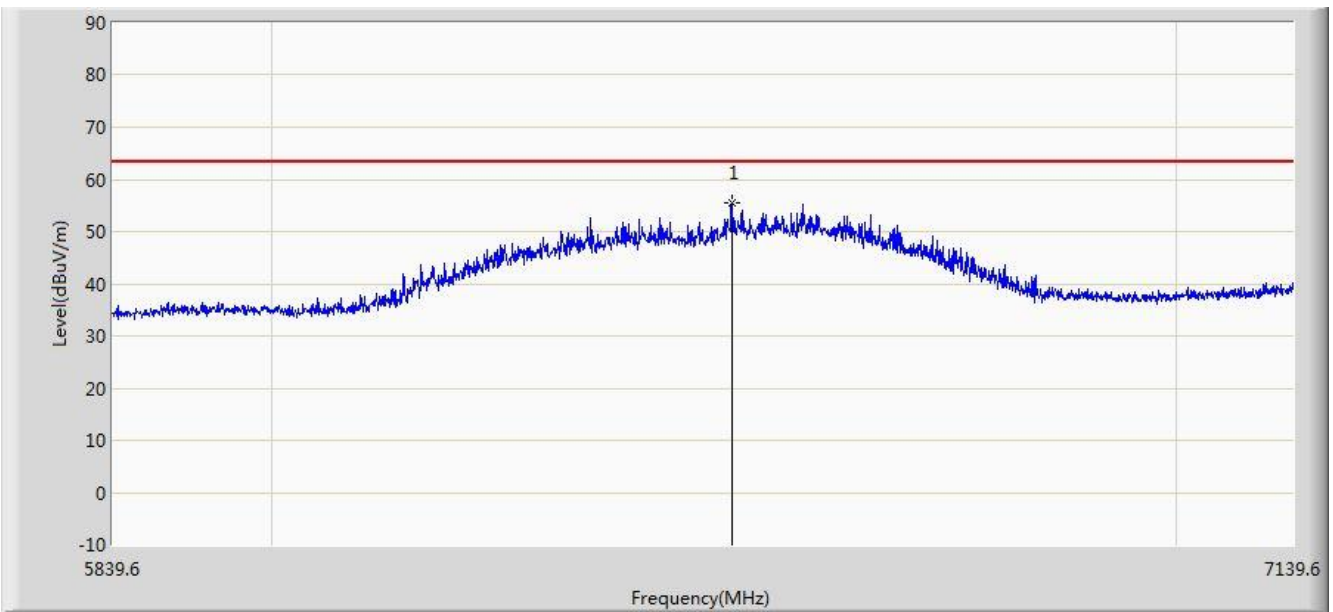

No	Flag	Mark	Frequency (MHz)	Measure Level (dBuV/m)	Reading Level (dBuV)	Over Limit (dB)	Limit (dBuV/m)	Factor	Type
1		*	6490.250	55.383	49.480	-8.057	63.440	5.903	AV

Note: Measure Level (dB μ V/m) = Reading Level (dB μ V) + Factor (dB)

Factor (dB) = Cable Loss (dB) + Antenna Factor (dB/m) - Pre_Amplifier Gain (dB).

Site: AC1	Time: 2017/08/07 - 18:53
Limit: FCC_Part 15.519(e)_(1m)	Engineer: Will Yan
Probe: BBHA9120D_1-18GHz	Polarity: Vertical
EUT: Segway miniPLUS	Power: By Battery

Note: Bandwidth conversion of peak power measurements

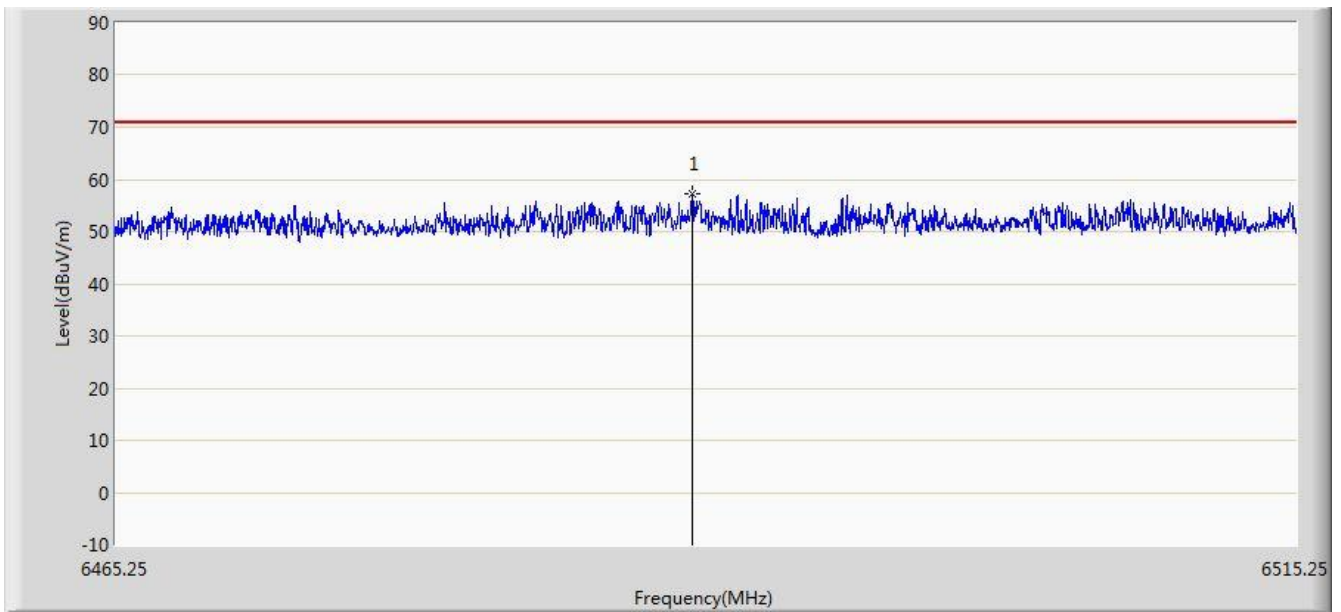

No	Flag	Mark	Frequency (MHz)	Measure Level (dBuV/m)	Reading Level (dBuV)	Over Limit (dB)	Limit (dBuV/m)	Factor	Type
1		*	6489.625	57.119	51.219	-13.621	70.740	5.899	PK

Note: Measure Level (dBμV/m) = Reading Level (dBμV) + Factor (dB)

Factor (dB) = Cable Loss (dB) + Antenna Factor (dB/m) - Pre_Amplifier Gain (dB).

7.4. Radiated spurious emission measurements

7.4.1. Test Limit

The FCC limit of radiated emission below 960MHz

FCC Part 15 Subpart C Paragraph 15.209		
Frequency [MHz]	Field Strength [$\mu\text{V}/\text{m}$]	Measured Distance [Meters]
0.009 - 0.490	2400/F (kHz)	300
0.490 - 1.705	24000/F (kHz)	30
1.705 - 30	30	30
30 - 88	100	3
88 - 216	150	3
216 - 960	200	3
Above 960	500	3

The FCC limit of radiated emission above 960MHz

Radiated emission average limits according to sections 15.519(c), 15.519(d)			
Frequency [MHz]	RBW [kHz]	EIRP of spurious [dBm]	Equivalent field strength limit @ 1m [$\text{dB}(\mu\text{V}/\text{m})$]
960 - 1610	1000	-75.3	29.4
1610 - 1990	1000	-63.3	41.4
1990 - 3100	1000	-61.3	43.4
3100 - 10600	1000	-41.3	63.4
Above 10600	1000	-61.3	43.4
1164 - 1240	≥ 1	-85.3	19.4
1559 - 1610	≥ 1	-85.3	19.4

The IC limit of radiated emission above 960MHz

Radiated emission average limits according to RSS-220 section 5.3.1(d)			
Frequency [MHz]	RBW [kHz]	EIRP of spurious [dBm]	Equivalent field strength limit @ 1m [$\text{dB}(\mu\text{V}/\text{m})$]
960 - 1610	1000	-75.3	29.4
1610 - 4750	1000	-70.0	41.4
4750 - 10600	1000	-41.3	63.4
Above 10600	1000	-61.3	43.4
1164 - 1240	≥ 1	-85.3	19.4
1559 - 1610	≥ 1	-85.3	19.4

Note: Equivalent field strength ($\text{dB}(\mu\text{V}/\text{m})$) = EIRP (dBm) + 95.2 + 20*log(3m/1m)

7.4.2. Test Procedure Used

ANSI C63.10-2013, sections 10.2, 10.3

7.4.3. Test Setting

The measurement setup is similar to that described in 10.3.7. The rms detector is selected, and the sweep time and number of measurement bins are set to provide the requisite 1 ms integration time. In this test, the RBW may be reduced to a minimum of 1 kHz (30 kHz is recommended) to enhance the resolution of the individual spectral lines. A ratio of $VBW / RBW > 3$ shall be maintained when possible.

7.4.4. Test Setup

9kHz ~ 30MHz Test Setup:

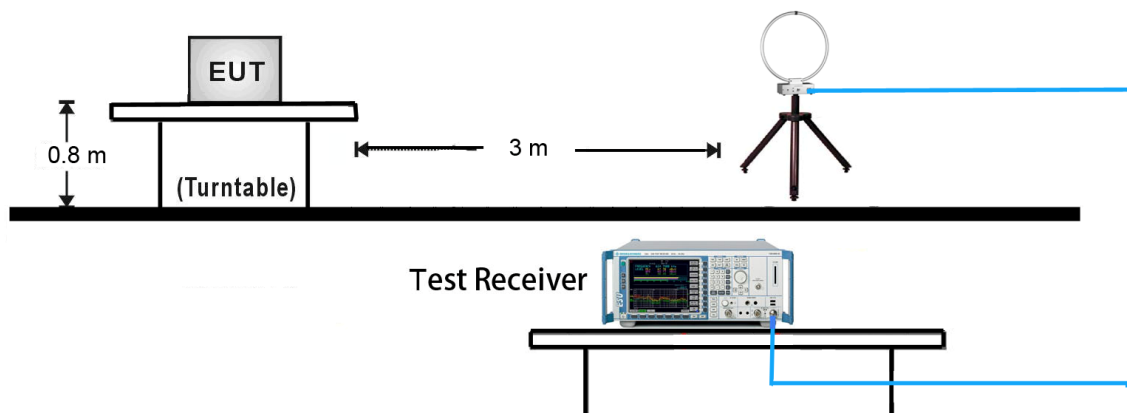

30MHz ~ 1GHz Test Setup:

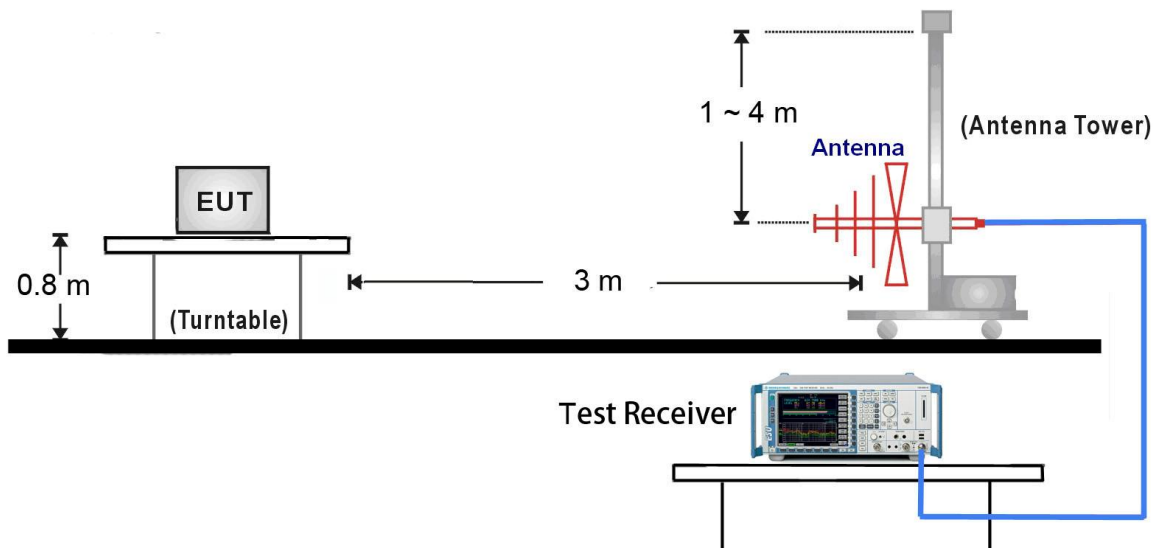

1GHz ~ 40GHz Test Setup:

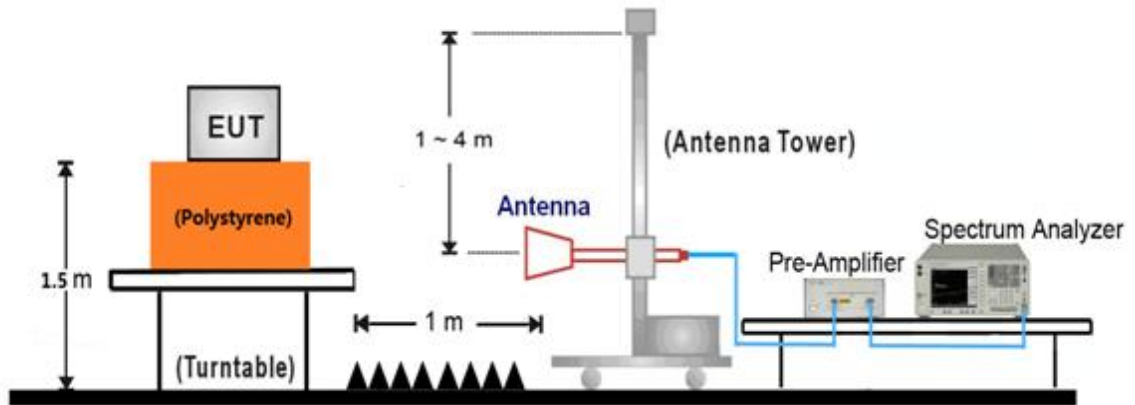

7.4.5. Test Result

Radiated Emission below 960MHz Test Result Summary

Frequency (MHz)	Equivalent field strength dB μ v/m(MHz)	Limit dB μ v/m(MHz)	Margin (dB)	Polarity	Verdict
83.73	16.84	40.00	-23.16	Horizontal	Pass
146.18	24.98	43.50	-18.52	Horizontal	Pass
281.18	32.52	46.00	-13.48	Horizontal	Pass
299.48	34.40	46.00	-11.60	Horizontal	Pass
345.78	29.45	46.00	-16.55	Horizontal	Pass
474.12	28.50	46.00	-17.50	Horizontal	Pass
80.23	24.19	40.00	-15.81	Vertical	Pass
111.50	29.80	43.50	-13.70	Vertical	Pass
143.12	30.49	43.50	-13.01	Vertical	Pass
201.83	32.71	43.50	-10.79	Vertical	Pass
345.13	30.78	46.00	-15.22	Vertical	Pass
476.15	27.16	46.00	-18.84	Vertical	Pass

Note 1: The Margin = Equivalent field strength - Limit.
 Note 2: The detail test plots have been showed as below.

Site: AC1	Time: 2017/08/07 - 22:30
Limit: FCC_Part15.209_RE(3m)	Engineer: Will Yan
Probe: VULB 9168_20-2000MHz	Polarity: Horizontal
EUT: Segway miniPLUS	Power: By Battery
Note: Transmit with UWB function	

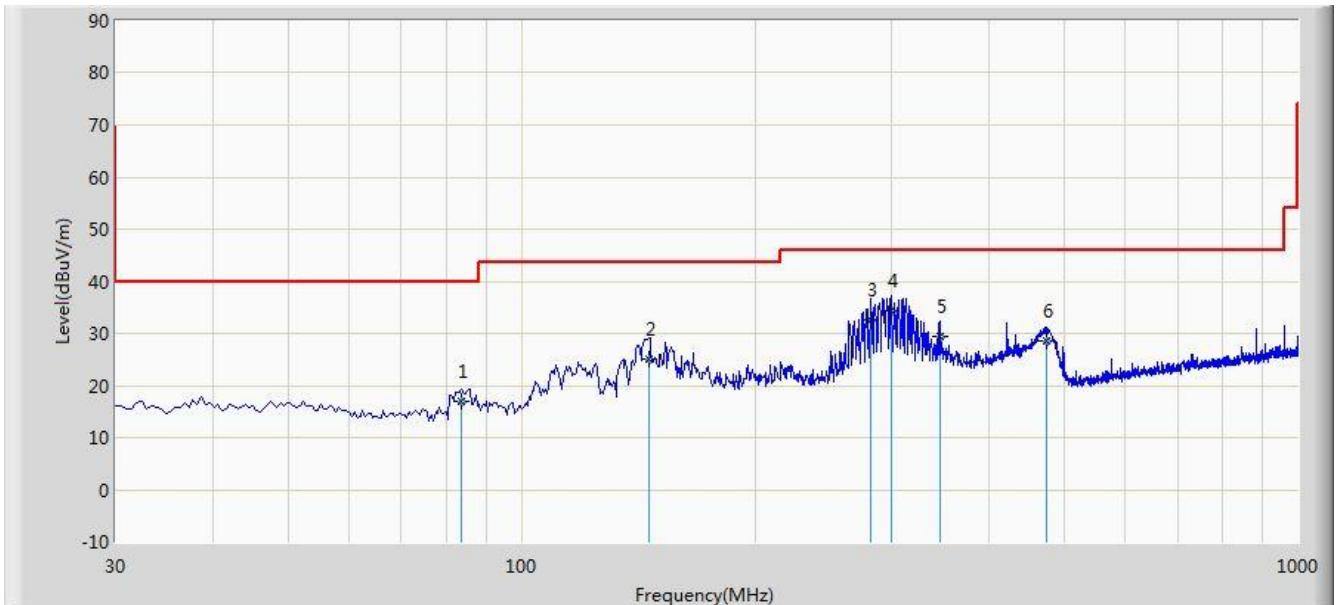

No	Flag	Mark	Frequency (MHz)	Measure Level (dBuV/m)	Reading Level (dBuV)	Over Limit (dB)	Limit (dBuV/m)	Factor	Type
1			83.726	16.837	6.723	-23.163	40.000	10.115	QP
2			146.183	24.973	10.048	-18.527	43.500	14.925	QP
3			281.176	32.512	18.715	-13.488	46.000	13.797	QP
4		*	299.475	34.396	20.158	-11.604	46.000	14.238	QP
5			345.781	29.451	14.128	-16.549	46.000	15.323	QP
6			474.124	28.499	10.487	-17.501	46.000	18.012	QP

Note 1: Measure Level (dB μ V/m) = Reading Level (dB μ V) + Factor (dB)

Factor (dB) = Cable Loss (dB) + Antenna Factor (dB/m)

Note 2: The test trace is same as the ambient noise and the amplitude of the emissions are attenuated more than 20dB below the permissible (the test frequency range: 9kHz ~ 30MHz), therefore no data appear in the report.

Site: AC1	Time: 2017/08/07 - 22:53
Limit: FCC_Part15.209_RE(3m)	Engineer: Will Yan
Probe: VULB 9168_20-2000MHz	Polarity: Vertical
EUT: Segway miniPLUS	Power: By Battery
Note: Transmit with UWB function	

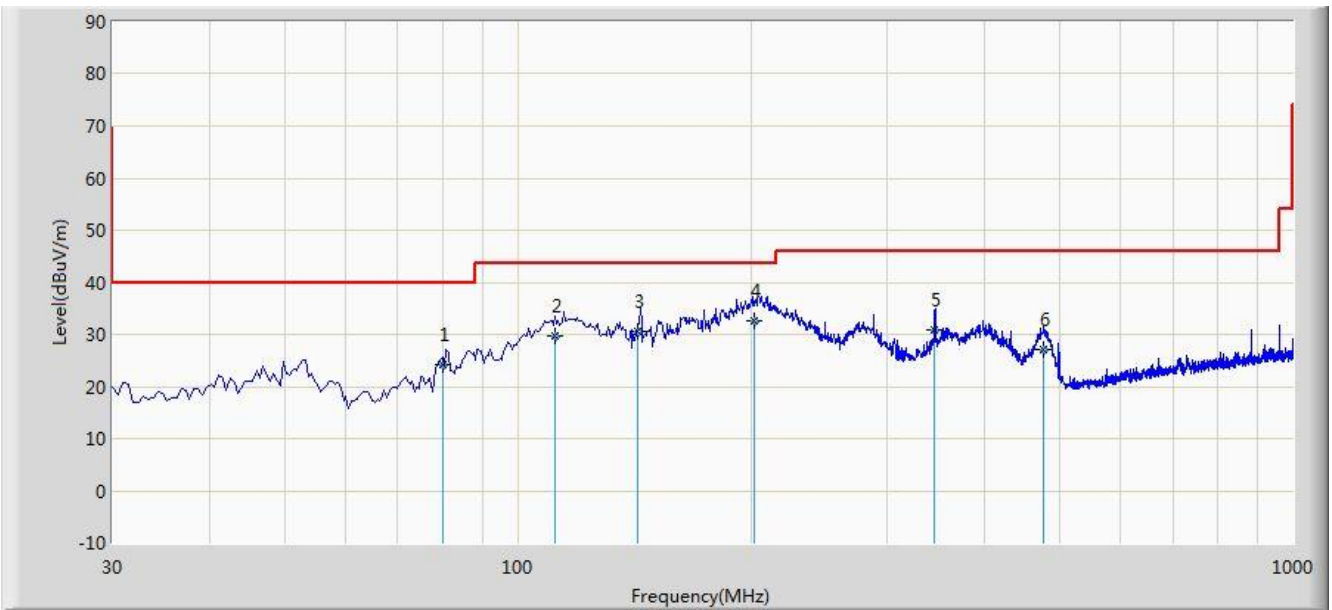

No	Flag	Mark	Frequency (MHz)	Measure Level (dBuV/m)	Reading Level (dBuV)	Over Limit (dB)	Limit (dBuV/m)	Factor	Type
1			80.226	24.195	14.091	-15.805	40.000	10.104	QP
2			111.495	29.799	17.618	-13.701	43.500	12.181	QP
3			143.119	30.488	15.772	-13.012	43.500	14.716	QP
4		*	201.825	32.709	21.590	-10.791	43.500	11.119	QP
5			345.125	30.784	15.472	-15.216	46.000	15.312	QP
6			476.153	27.154	9.115	-18.846	46.000	18.040	QP

Note 1: Measure Level (dB μ V/m) = Reading Level (dB μ V) + Factor (dB)

Factor (dB) = Cable Loss (dB) + Antenna Factor (dB/m)

Note 2: The test trace is same as the ambient noise and the amplitude of the emissions are attenuated more than 20dB below the permissible (the test frequency range: 9kHz ~ 30MHz), therefore no data appear in the report.

Radiated Emission above 960MHz Test Result Summary

Frequency Range (MHz)	Equivalent field strength in MHz (dB μ v/m)	Limit in MHz (dB μ v/m)	Margin (dB)	Polarity	Verdict
960 ~ 1610	27.78	29.40	-1.62	Horizontal	Pass
	26.53	29.40	-2.87	Vertical	Pass
1610 ~ 1990	23.11	41.40	-18.29	Horizontal	Pass
	23.44	41.40	-17.96	Vertical	Pass
1990 ~ 3100	48.24	43.40	-15.16	Horizontal	Pass
	52.93	43.40	-10.47	Vertical	Pass
3100 ~ 10600	40.50	63.40	-2.90	Horizontal	Pass
	40.64	63.40	-2.76	Vertical	Pass
Above 10600	27.78	43.40	-1.62	Horizontal	Pass
	26.53	43.40	-2.87	Vertical	Pass

Note 1: The Margin = Equivalent field strength – Limit.
 Note 2: The detail test plots have been showed as below.

Site: AC1	Time: 2017/08/07 - 19:10
Limit: FCC_Part 15.519(c)_RMS (1M)	Engineer: Will Yan
Probe: BBHA9120D_1-18GHz	Polarity: Horizontal
EUT: Segway miniPLUS	Power: By Battery
Note: Transmit with UWB function	

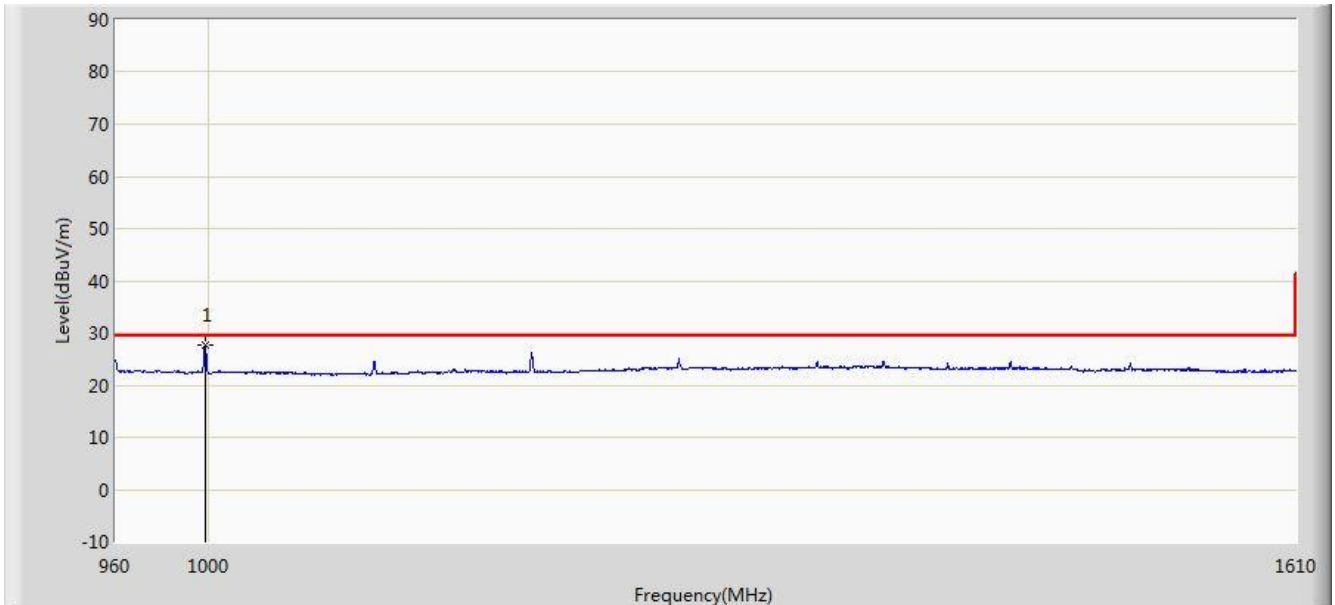

No	Flag	Mark	Frequency (MHz)	Measure Level (dBuV/m)	Reading Level (dBuV)	Over Limit (dB)	Limit (dBuV/m)	Factor	Type
1		*	998.350	27.776	39.030	-1.624	29.400	-11.254	AV

Note: Measure Level (dB μ V/m) = Reading Level (dB μ V) + Factor (dB)

Factor (dB) = Cable Loss (dB) + Antenna Factor (dB/m) - Pre_Amplifier Gain (dB)

Site: AC1	Time: 2017/08/07 - 19:21
Limit: FCC_Part 15.519(c)_RMS (1M)	Engineer: Will Yan
Probe: BBHA9120D_1-18GHz	Polarity: Vertical
EUT: Segway miniPLUS	Power: By Battery
Note: Transmit with UWB function	

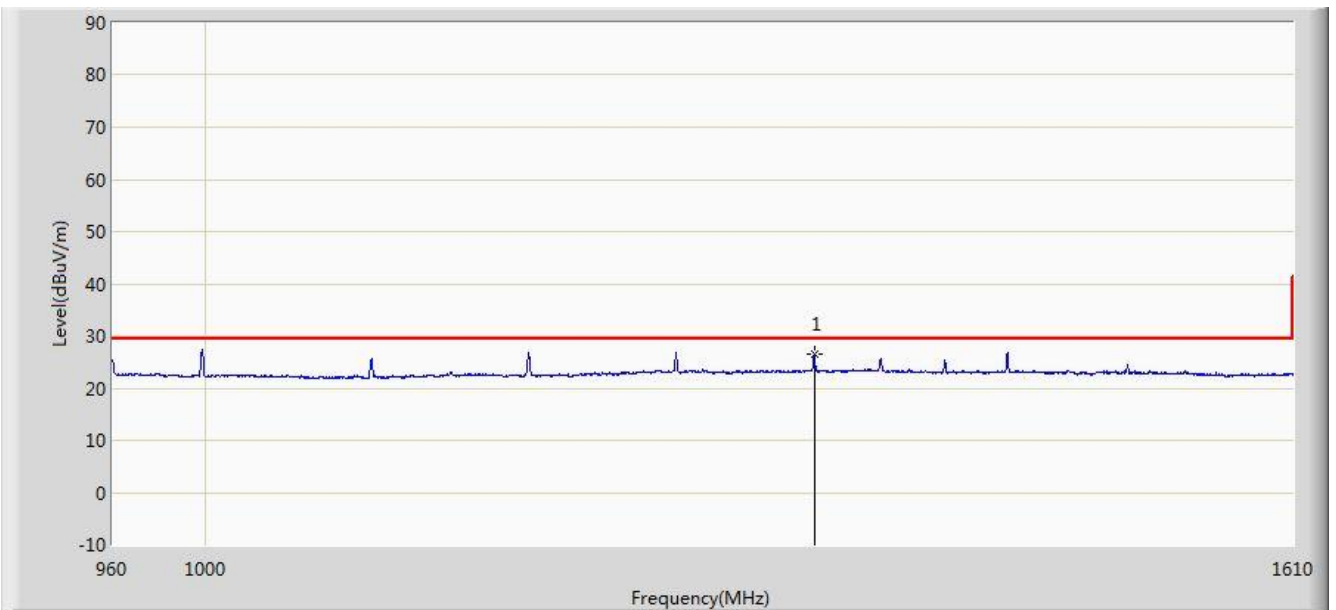

No	Flag	Mark	Frequency (MHz)	Measure Level (dBuV/m)	Reading Level (dBuV)	Over Limit (dB)	Limit (dBuV/m)	Factor	Type
1		*	1305.475	26.528	34.736	-2.872	29.400	-8.208	AV

Note: Measure Level (dB μ V/m) = Reading Level (dB μ V) + Factor (dB)

Factor (dB) = Cable Loss (dB) + Antenna Factor (dB/m) - Pre_Amplifier Gain (dB)

Site: AC1	Time: 2017/08/07 - 19:30
Limit: FCC_Part 15.519(c)_RMS (1M)	Engineer: Will Yan
Probe: BBHA9120D_1-18GHz	Polarity: Horizontal
EUT: Segway miniPLUS	Power: By Battery
Note: Transmit with UWB function	

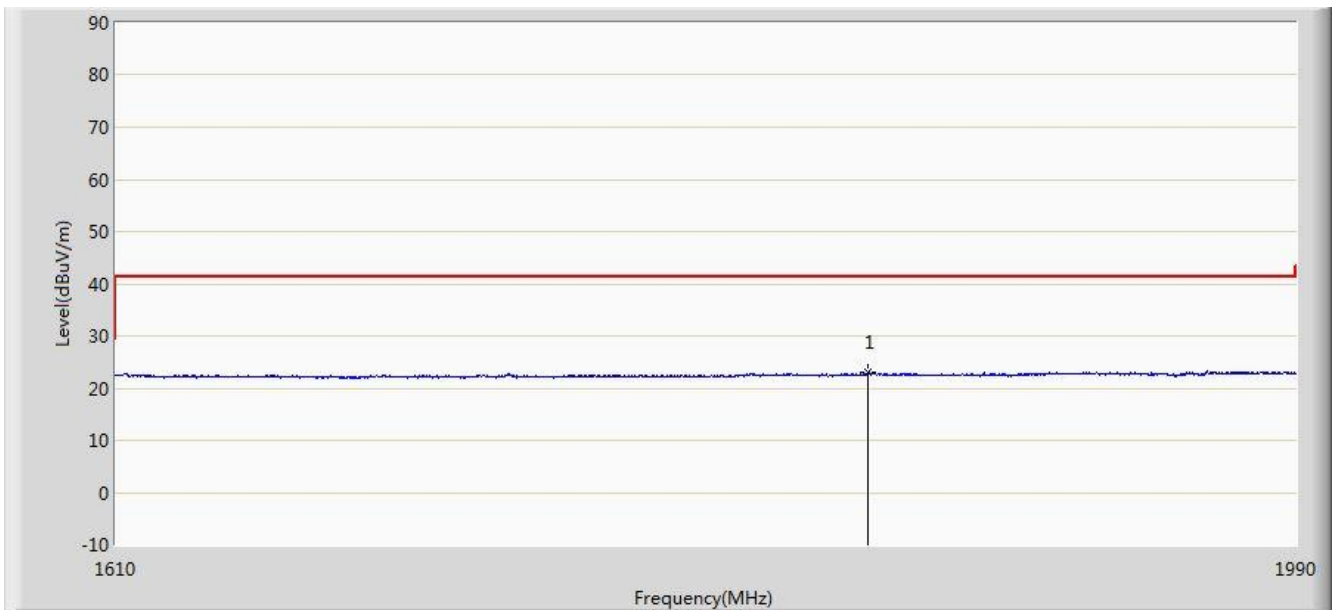

No	Flag	Mark	Frequency (MHz)	Measure Level (dBuV/m)	Reading Level (dBuV)	Over Limit (dB)	Limit (dBuV/m)	Factor	Type
1		*	1842.940	23.105	29.773	-18.295	41.400	-6.668	AV

Note: Measure Level (dB μ V/m) = Reading Level (dB μ V) + Factor (dB)

Factor (dB) = Cable Loss (dB) + Antenna Factor (dB/m) - Pre_Amplifier Gain (dB)

Site: AC1	Time: 2017/08/07 - 19:35
Limit: FCC_Part 15.519(c)_RMS (1M)	Engineer: Will Yan
Probe: BBHA9120D_1-18GHz	Polarity: Vertical
EUT: Segway miniPLUS	Power: By Battery
Note: Transmit with UWB function	

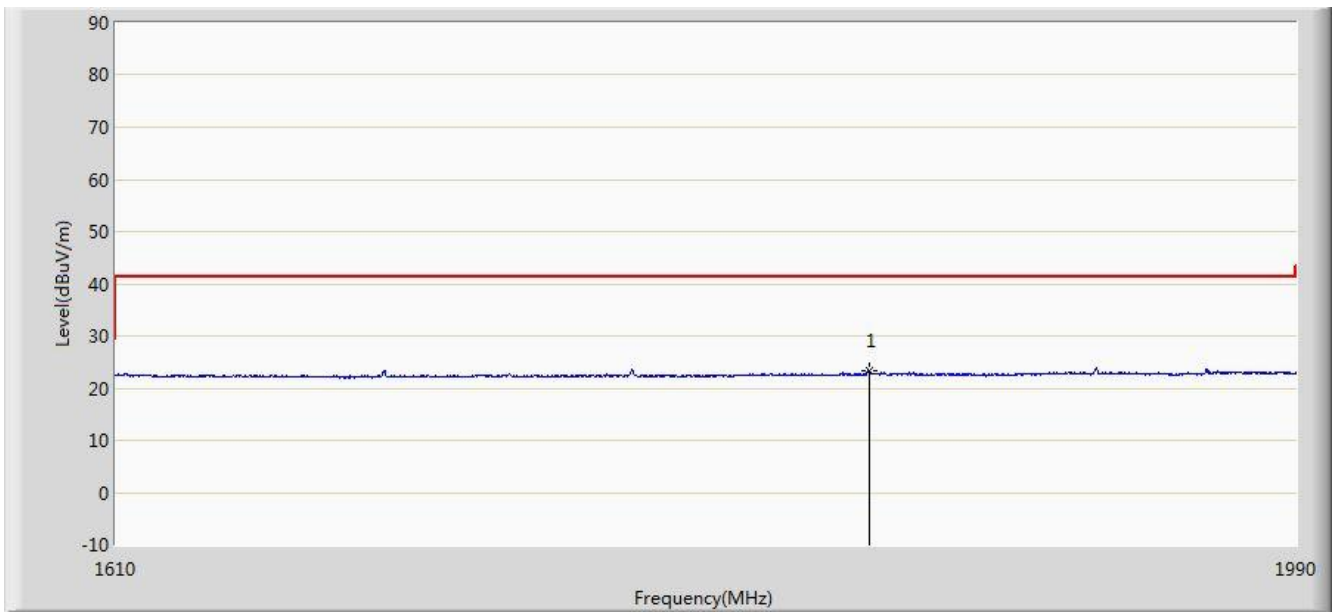

No	Flag	Mark	Frequency (MHz)	Measure Level (dBuV/m)	Reading Level (dBuV)	Over Limit (dB)	Limit (dBuV/m)	Factor	Type
1		*	1843.130	23.437	30.104	-17.963	41.400	-6.667	AV

Note: Measure Level (dB μ V/m) = Reading Level (dB μ V) + Factor (dB)

Factor (dB) = Cable Loss (dB) + Antenna Factor (dB/m) - Pre_Amplifier Gain (dB)

Site: AC1	Time: 2017/08/07 - 19:39
Limit: FCC_Part 15.519(c)_RMS (1M)	Engineer: Alex Ma
Probe: BBHA9120D_1-18GHz	Polarity: Horizontal
EUT: Segway miniPLUS	Power: By Battery
Note: Transmit with UWB function	

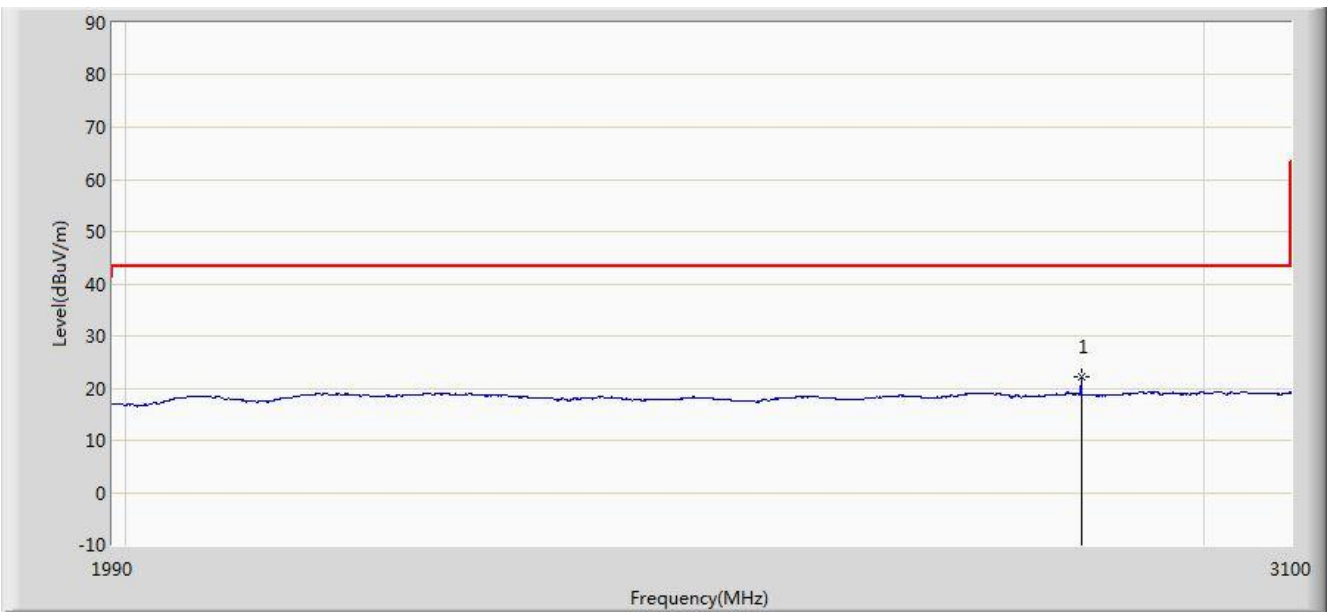

No	Flag	Mark	Frequency (MHz)	Measure Level (dBuV/m)	Reading Level (dBuV)	Over Limit (dB)	Limit (dBuV/m)	Factor	Type
1		*	2864.680	22.298	24.649	-21.102	43.400	-2.351	AV

Note: Measure Level (dB μ V/m) = Reading Level (dB μ V) + Factor (dB)

Factor (dB) = Cable Loss (dB) + Antenna Factor (dB/m) - Pre_Amplifier Gain (dB)

Site: AC1	Time: 2017/08/07 - 19:39
Limit: FCC_Part 15.519(c)_RMS (1M)	Engineer: Alex Ma
Probe: BBHA9120D_1-18GHz	Polarity: Vertical
EUT: Segway miniPLUS	Power: By Battery
Note: Transmit with UWB function	

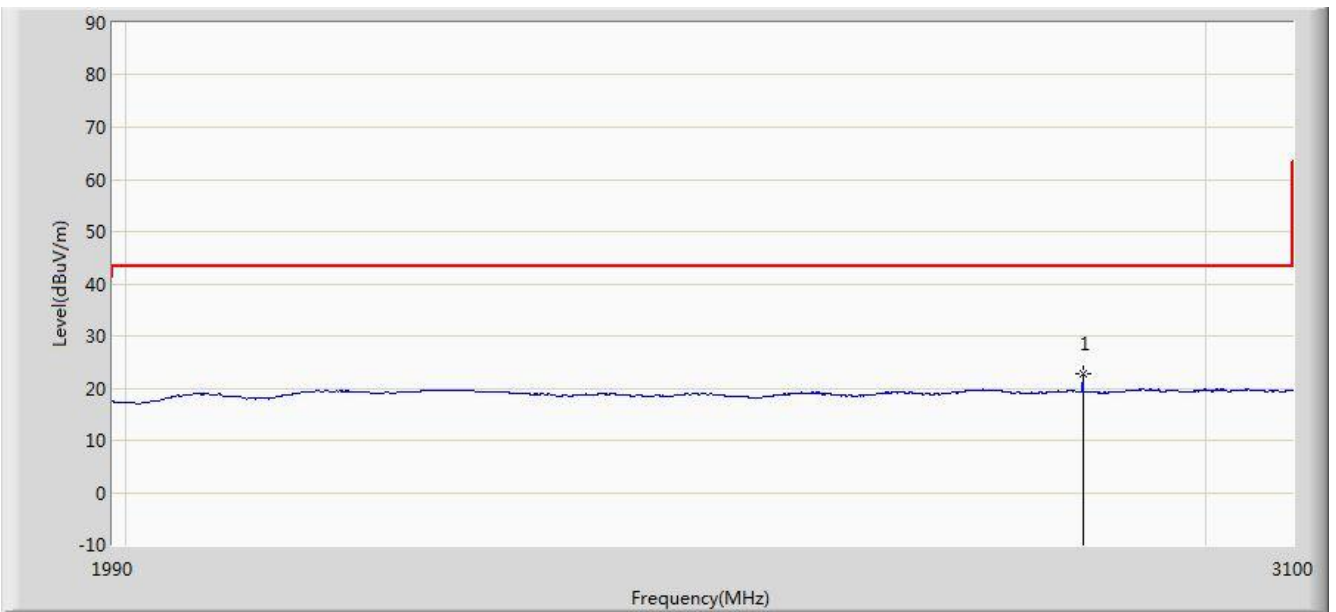

No	Flag	Mark	Frequency (MHz)	Measure Level (dBuV/m)	Reading Level (dBuV)	Over Limit (dB)	Limit (dBuV/m)	Factor	Type
1		*	2864.680	22.814	25.165	-20.586	43.400	-2.351	AV

Note: Measure Level (dB μ V/m) = Reading Level (dB μ V) + Factor (dB)

Factor (dB) = Cable Loss (dB) + Antenna Factor (dB/m) - Pre_Amplifier Gain (dB)

Site: AC1	Time: 2017/08/07 - 19:45
Limit: FCC_Part 15.519(c)_RMS (1M)	Engineer: Will Yan
Probe: BBHA9120D_1-18GHz	Polarity: Horizontal
EUT: Segway miniPLUS	Power: By Battery
Note: Transmit with UWB function	

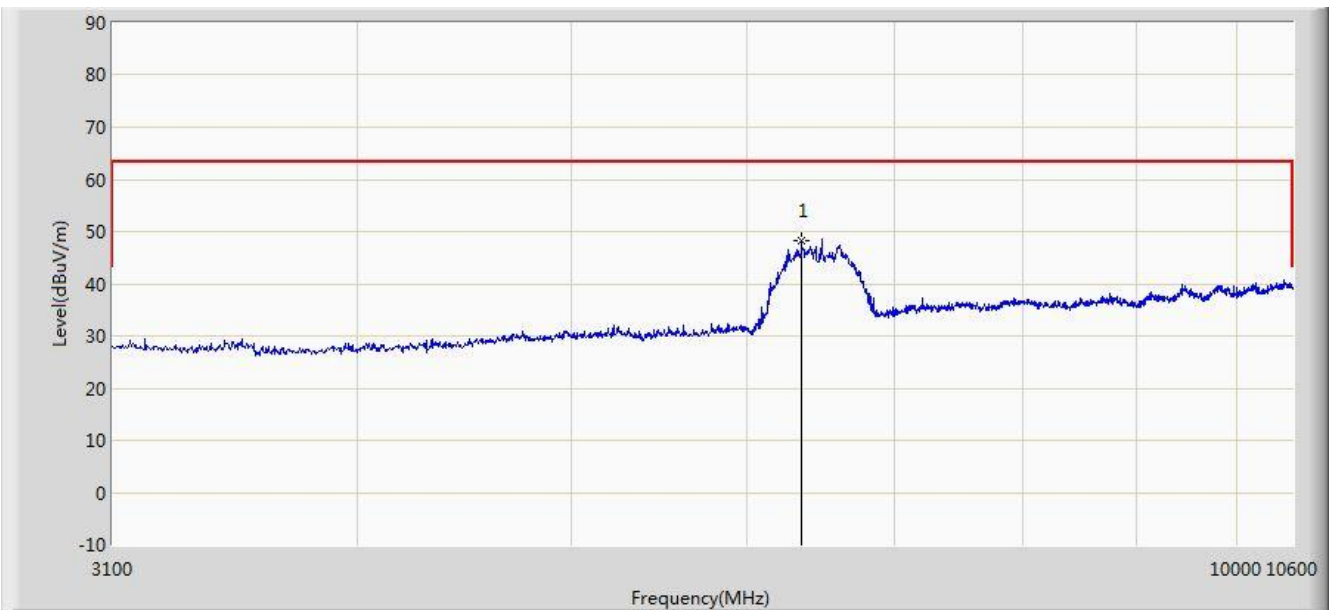

No	Flag	Mark	Frequency (MHz)	Measure Level (dBuV/m)	Reading Level (dBuV)	Over Limit (dB)	Limit (dBuV/m)	Factor	Type
1		*	6355.000	48.238	43.067	-15.162	63.400	5.171	AV

Note: Measure Level (dB μ V/m) = Reading Level (dB μ V) + Factor (dB)

Factor (dB) = Cable Loss (dB) + Antenna Factor (dB/m) - Pre_Amplifier Gain (dB)

Site: AC1	Time: 2017/08/07 - 19:57
Limit: FCC_Part 15.519(c)_RMS (1M)	Engineer: Will Yan
Probe: BBHA9120D_1-18GHz	Polarity: Vertical
EUT: Segway miniPLUS	Power: By Battery
Note: Transmit with UWB function	

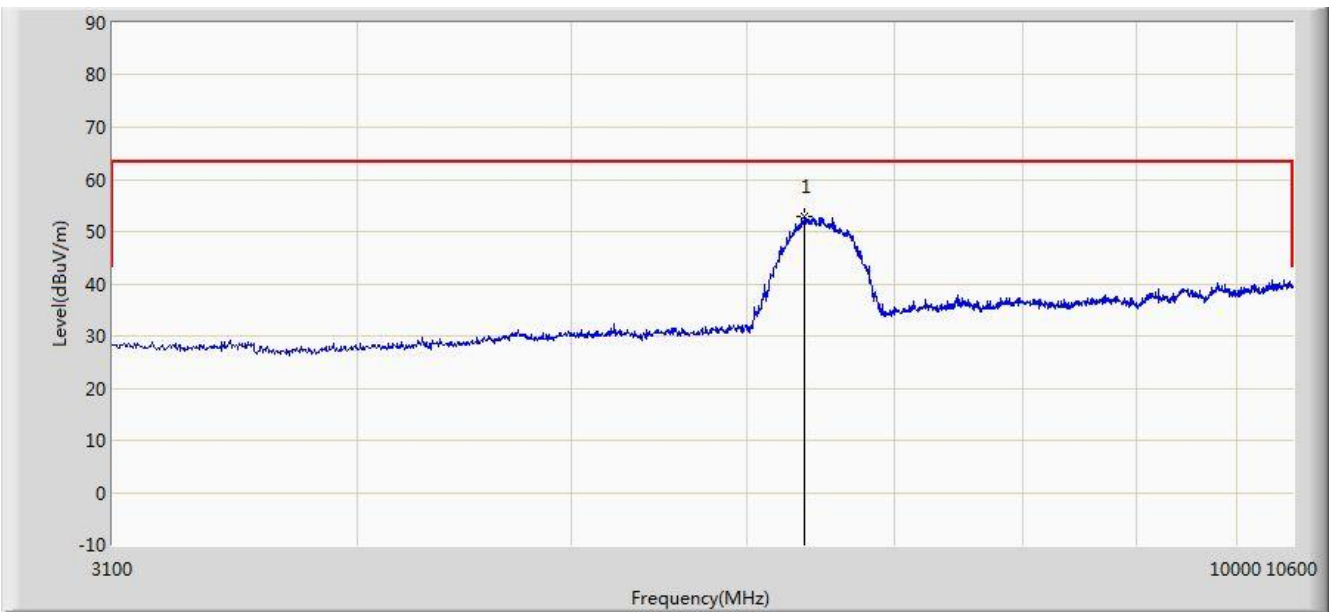

No	Flag	Mark	Frequency (MHz)	Measure Level (dBuV/m)	Reading Level (dBuV)	Over Limit (dB)	Limit (dBuV/m)	Factor	Type
1		*	6373.750	52.932	47.659	-10.468	63.400	5.273	AV

Note: Measure Level (dB μ V/m) = Reading Level (dB μ V) + Factor (dB)

Factor (dB) = Cable Loss (dB) + Antenna Factor (dB/m) - Pre_Amplifier Gain (dB)

Site: AC1	Time: 2017/08/07 - 20:03
Limit: FCC_Part 15.519(c)_RMS (1M)	Engineer: Will Yan
Probe: BBHA9120D_1-18GHz	Polarity: Horizontal
EUT: Segway miniPLUS	Power: By Battery
Note: Transmit with UWB function	

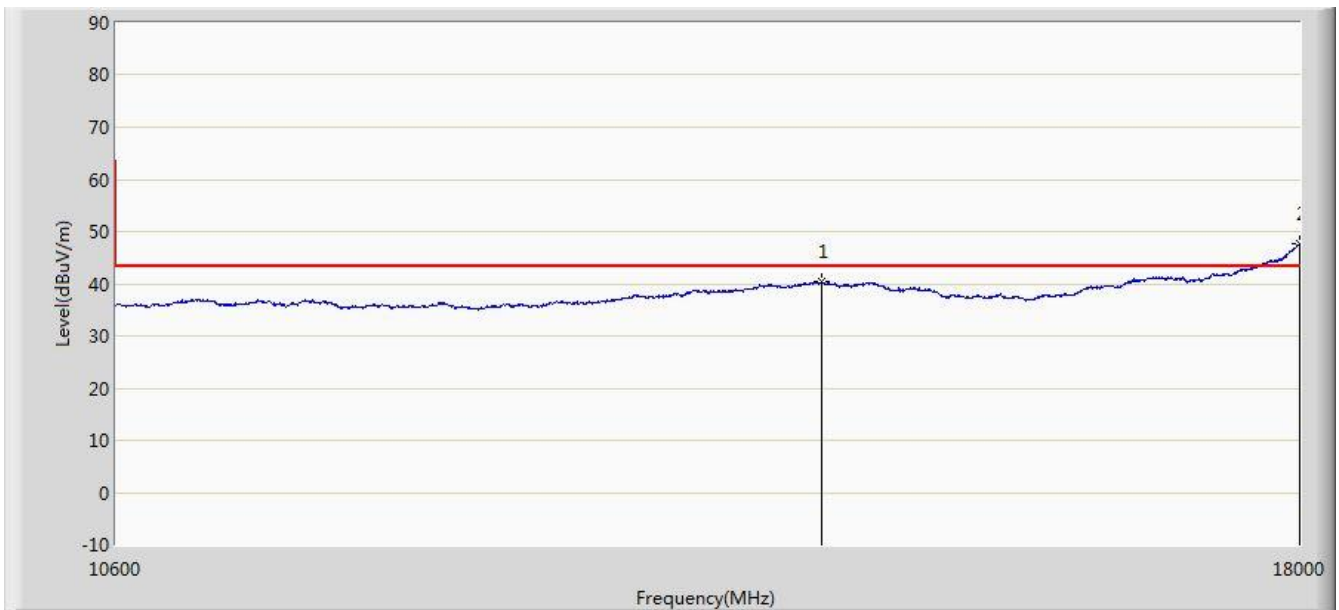

No	Flag	Mark	Frequency (MHz)	Measure Level (dBuV/m)	Reading Level (dBuV)	Over Limit (dB)	Limit (dBuV/m)	Factor	Type
1			14533.100	40.496	24.807	-2.904	43.400	15.689	AV
2		*	17996.301	47.742	24.857	N/A	N/A	22.885	AV

Note 1: Measure Level (dB μ V/m) = Reading Level (dB μ V) + Factor (dB)

Factor (dB) = Cable Loss (dB) + Antenna Factor (dB/m) - Pre_Amplifier Gain (dB)

Note 2: The test plot of this frequency range was base noise unrelated to the UWB transmission. We had reduced the RBW to assess this frequency range.

Site: AC1	Time: 2017/08/07 - 20:08
Limit: FCC_Part 15.519(c)_RMS (1M)	Engineer: Will Yan
Probe: BBHA9120D_1-18GHz	Polarity: Vertical
EUT: Segway miniPLUS	Power: By Battery
Note: Transmit with UWB function	

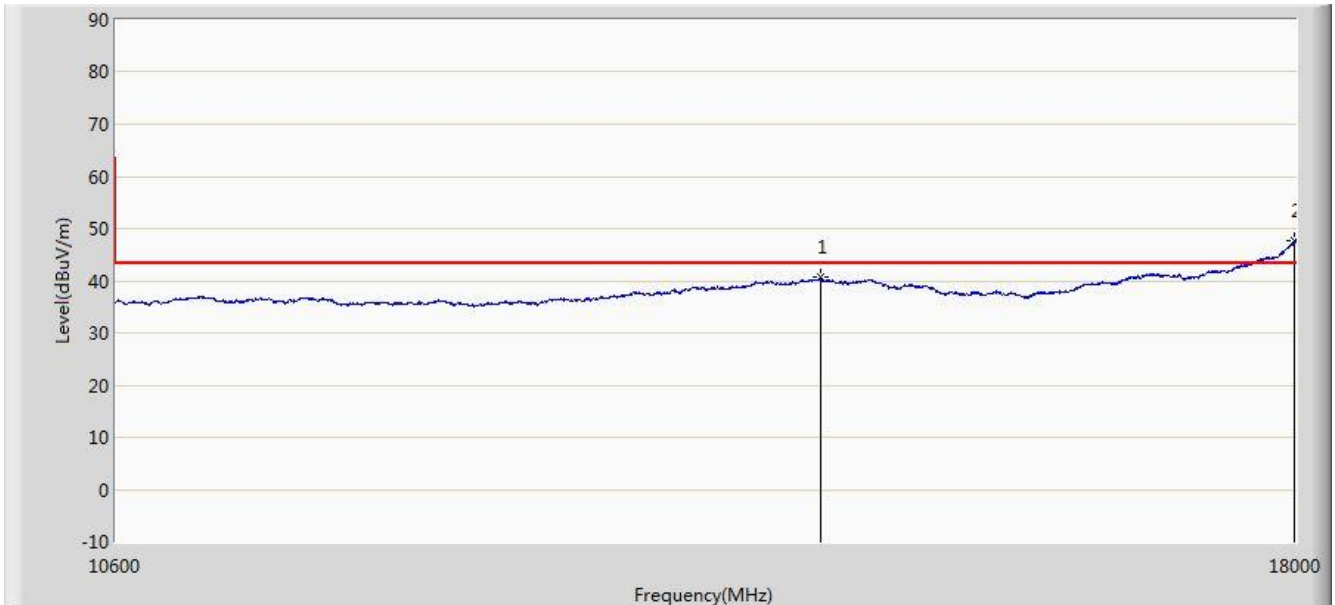

No	Flag	Mark	Frequency (MHz)	Measure Level (dBuV/m)	Reading Level (dBuV)	Over Limit (dB)	Limit (dBuV/m)	Factor	Type
1			14544.200	40.635	24.985	-2.765	43.400	15.649	AV
2		*	17992.600	47.707	24.904	N/A	N/A	22.803	AV

Note 1: Measure Level (dB μ V/m) = Reading Level (dB μ V) + Factor (dB)

Factor (dB) = Cable Loss (dB) + Antenna Factor (dB/m) - Pre_Amplifier Gain (dB)

Note 2: The test plot of this frequency range was base noise unrelated to the UWB transmission. We had reduced the RBW to assess this frequency range.

Site: AC1	Time: 2017/08/07 - 21:09
Limit: FCC_Part 15.519(c)_RMS (1m)	Engineer: Will Yan
Probe: BBHA9170_18-40GHz	Polarity: Horizontal
EUT: Segway miniPLUS	Power: By Battery
Note: Transmit with UWB function	

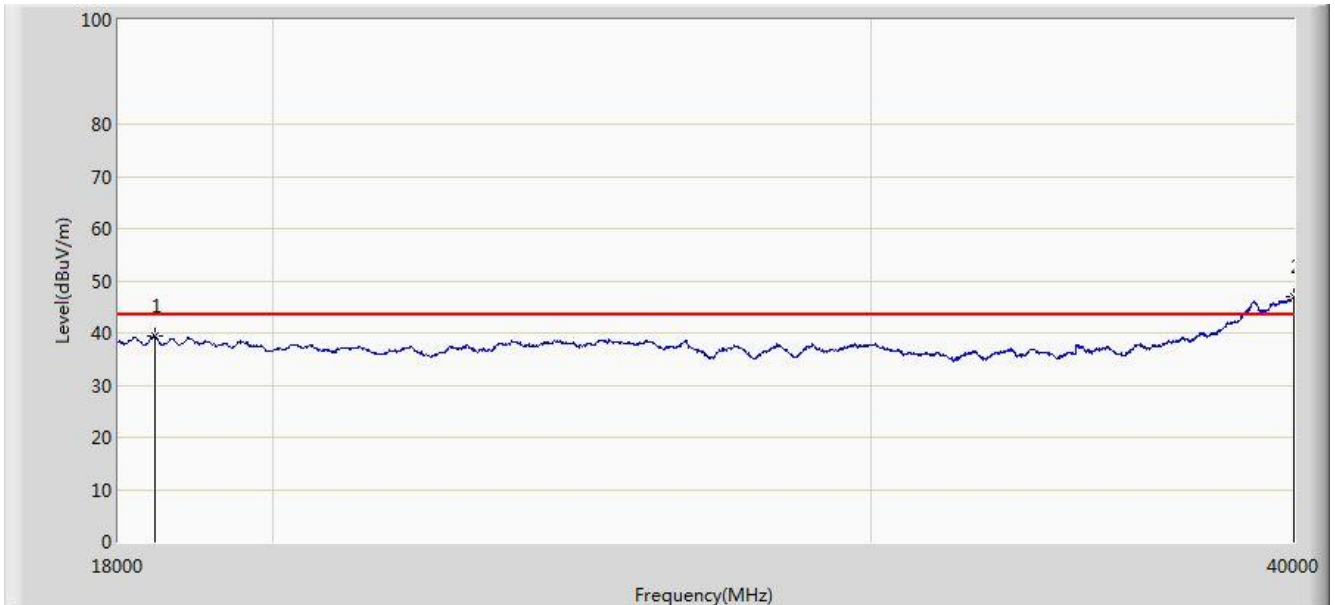

No	Flag	Mark	Frequency (MHz)	Measure Level (dBuV/m)	Reading Level (dBuV)	Over Limit (dB)	Limit (dBuV/m)	Factor	Type
1			18451.000	39.366	29.984	-4.034	43.400	9.382	AV
2		*	39989.000	46.888	27.924	N/A	N/A	18.964	AV

Note 1: Measure Level (dB μ V/m) = Reading Level (dB μ V) + Factor (dB)

Factor (dB) = Cable Loss (dB) + Antenna Factor (dB/m) - Pre_Amplifier Gain (dB)

Note 2: The test plot of this frequency range was base noise unrelated to the UWB transmission. We had reduced the RBW to assess this frequency range.

Site: AC1	Time: 2017/08/07 - 21:11
Limit: FCC_Part 15.519(c)_RMS (1m)	Engineer: Will Yan
Probe: BBHA9170_18-40GHz	Polarity: Vertical
EUT: Segway miniPLUS	Power: By Battery
Note: Transmit with UWB function	

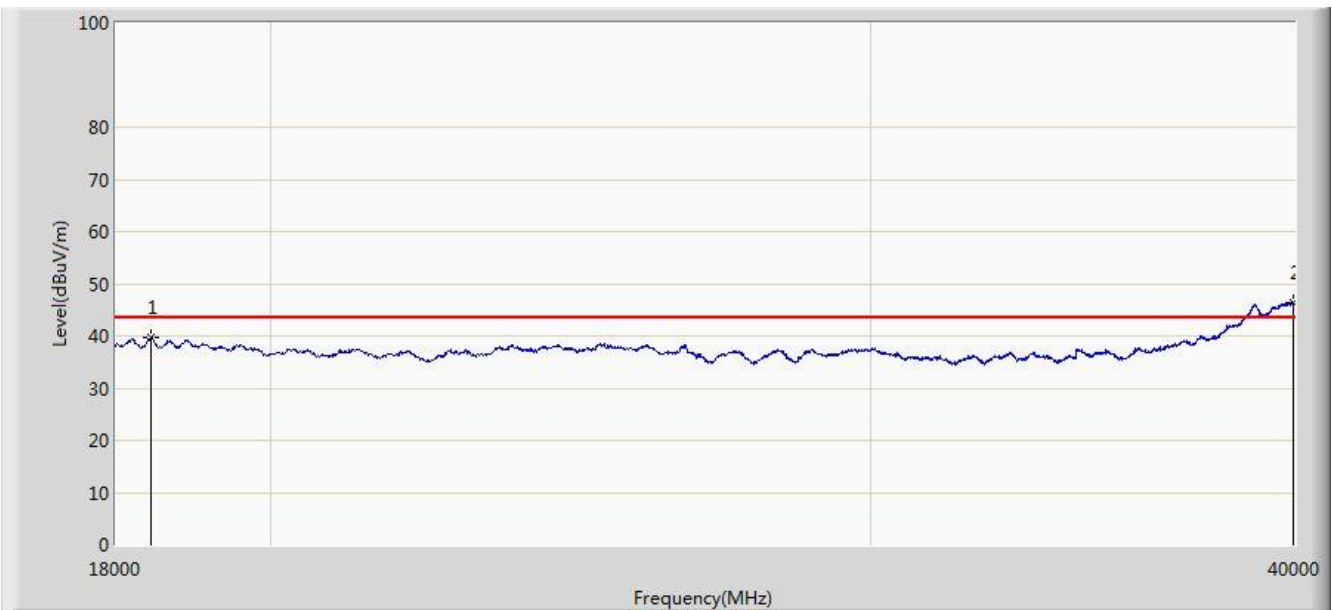

No	Flag	Mark	Frequency (MHz)	Measure Level (dBuV/m)	Reading Level (dBuV)	Over Limit (dB)	Limit (dBuV/m)	Factor	Type
1			18440.000	39.667	30.232	-3.733	43.400	9.435	AV
2		*	39978.000	46.497	27.610	N/A	N/A	18.887	AV

Note 1: Measure Level (dB μ V/m) = Reading Level (dB μ V) + Factor (dB)

Factor (dB) = Cable Loss (dB) + Antenna Factor (dB/m) - Pre_Amplifier Gain (dB)

Note 2: The test plot of this frequency range was base noise unrelated to the UWB transmission. We had reduced the RBW to assess this frequency range.

Radiated Emission in GPS Receive Band Test Result Summary

Frequency (MHz)	Equivalent field strength in MHz (dB μ V/m)	Limit in MHz (dB μ V/m)	Margin (dB)	Polarity	Verdict
1164 ~ 1240	4.95	19.40	-14.45	Horizontal	Pass
	10.48	19.40	-8.92	Vertical	Pass
1559 ~ 1610	0.50	19.40	-18.90	Horizontal	Pass
	1.13	19.40	-18.27	Vertical	Pass

Note 1: The Margin = Equivalent field strength – Limit.

Note 2: The detail test plots have been showed as below.

Site: AC1	Time: 2017/08/07 - 20:17
Limit: FCC_Part 15.519(d)_RMS (1M)	Engineer: Will Yan
Probe: BBHA9120D_1-18GHz	Polarity: Horizontal
EUT: Segway miniPLUS	Power: By Battery
Note: Transmit with UWB function	

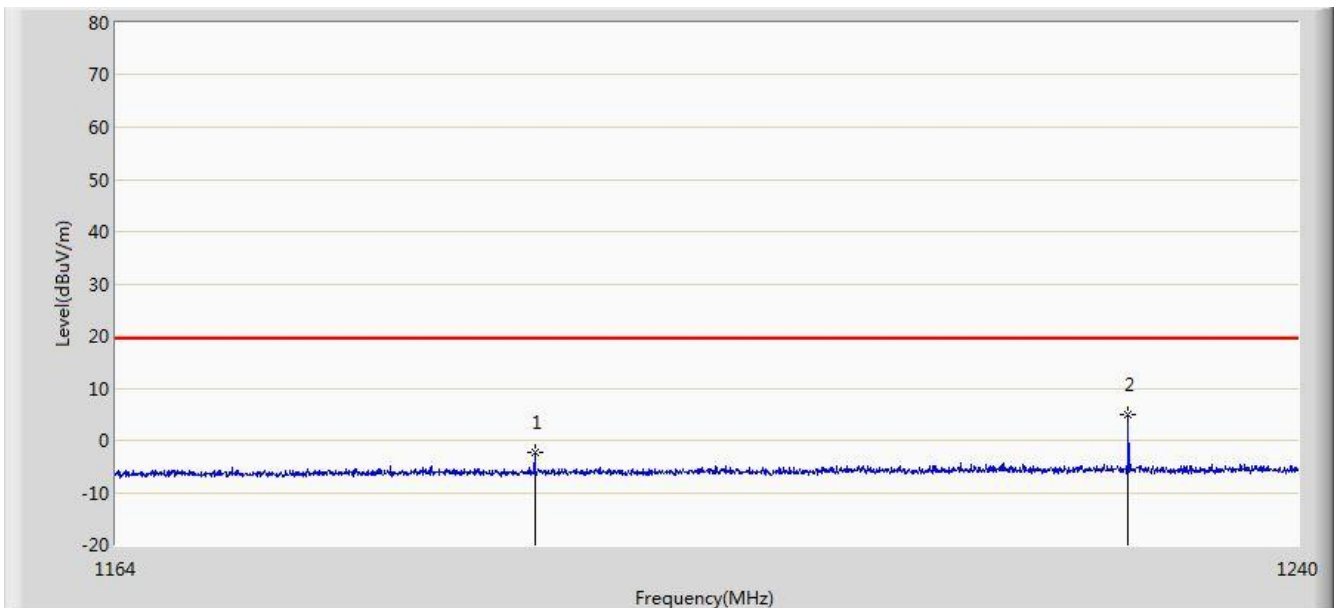

No	Flag	Mark	Frequency (MHz)	Measure Level (dBuV/m)	Reading Level (dBuV)	Over Limit (dB)	Limit (dBuV/m)	Factor	Type
1			1190.410	-2.279	7.069	-21.679	19.400	-9.347	AV
2		*	1228.790	4.948	13.762	-14.452	19.400	-8.813	AV

 Note: Measure Level (dB μ V/m) = Reading Level (dB μ V) + Factor (dB)

Factor (dB) = Cable Loss (dB) + Antenna Factor (dB/m) - Pre_Amplifier Gain (dB)

Site: AC1	Time: 2017/08/07 - 20:24
Limit: FCC_Part 15.519(d)_RMS (1M)	Engineer: Will Yan
Probe: BBHA9120D_1-18GHz	Polarity: Vertical
EUT: Segway miniPLUS	Power: By Battery
Note: Transmit with UWB function	

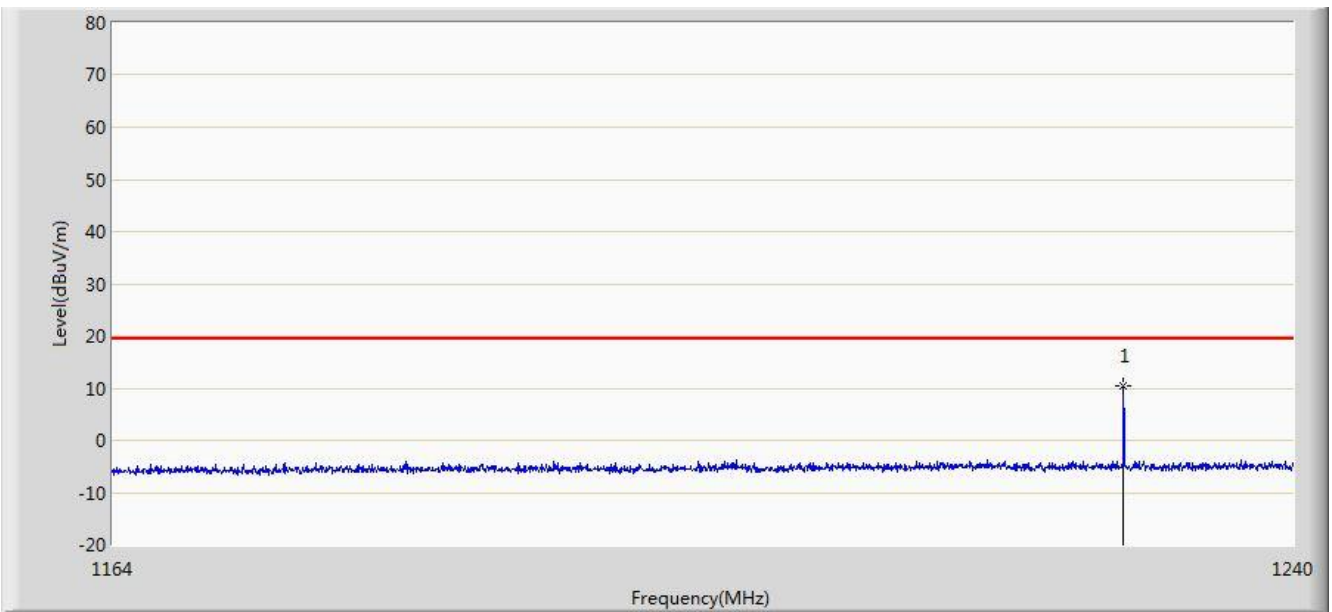

No	Flag	Mark	Frequency (MHz)	Measure Level (dBuV/m)	Reading Level (dBuV)	Over Limit (dB)	Limit (dBuV/m)	Factor	Type
1		*	1228.790	10.475	19.289	-8.925	19.400	-8.813	AV

Note: Measure Level (dB μ V/m) = Reading Level (dB μ V) + Factor (dB)

Factor (dB) = Cable Loss (dB) + Antenna Factor (dB/m) - Pre_Amplifier Gain (dB)

Site: AC1	Time: 2017/08/07 - 20:34
Limit: FCC_Part 15.519(d)_RMS (1M)	Engineer: Will Yan
Probe: BBHA9120D_1-18GHz	Polarity: Horizontal
EUT: Segway miniPLUS	Power: By Battery
Note: Transmit with UWB function	

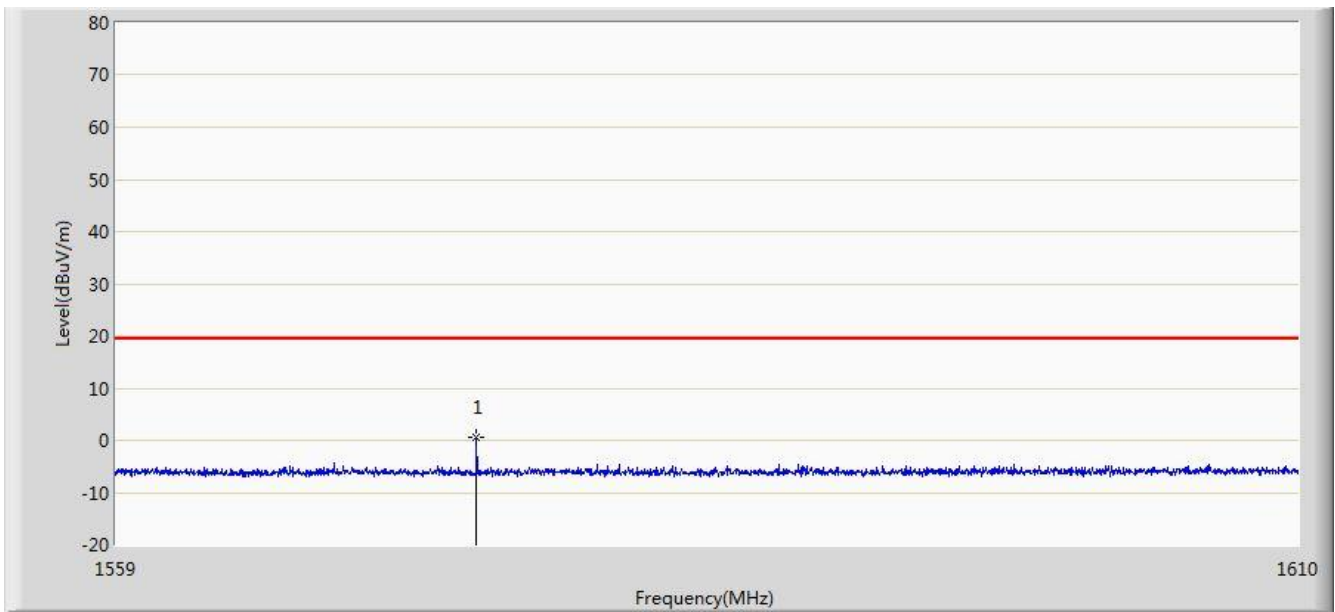

No	Flag	Mark	Frequency (MHz)	Measure Level (dBuV/m)	Reading Level (dBuV)	Over Limit (dB)	Limit (dBuV/m)	Factor	Type
1		*	1574.402	0.503	8.188	-18.897	19.400	-7.685	AV

Note: Measure Level (dBμV/m) = Reading Level (dBμV) + Factor (dB)

Factor (dB) = Cable Loss (dB) + Antenna Factor (dB/m) - Pre_Amplifier Gain (dB)

Site: AC1	Time: 2017/08/07 - 20:44
Limit: FCC_Part 15.519(d)_RMS (1M)	Engineer: Will Yan
Probe: BBHA9120D_1-18GHz	Polarity: Vertical
EUT: Segway miniPLUS	Power: By Battery
Note: Transmit with UWB function	

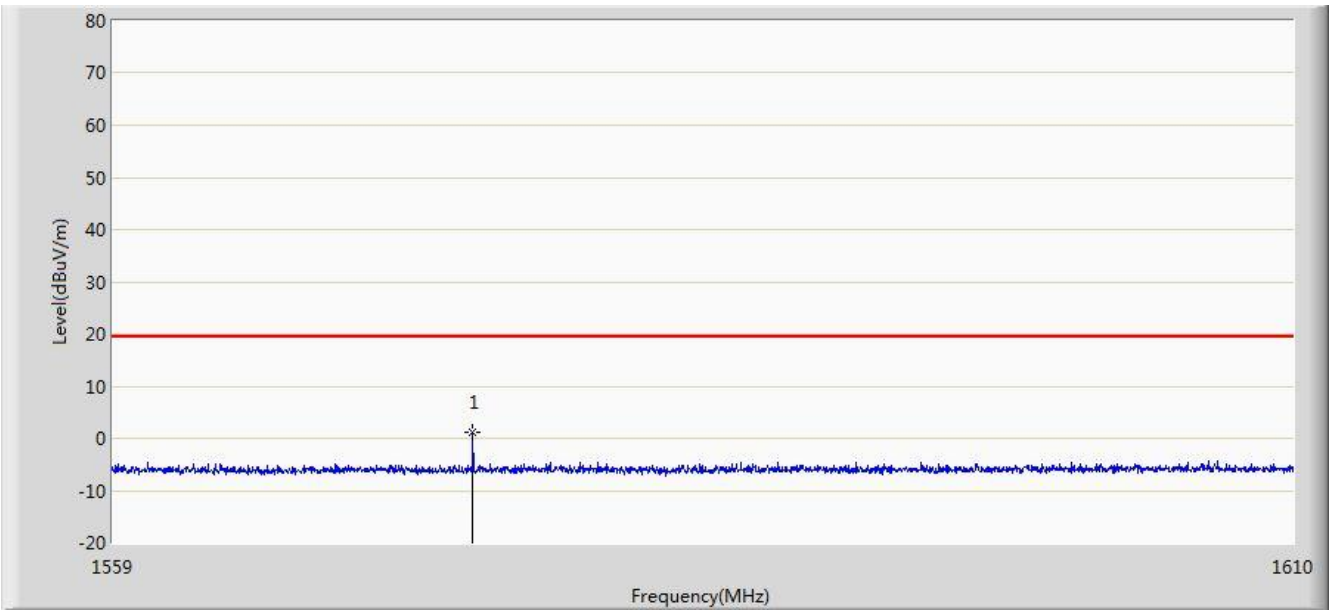

No	Flag	Mark	Frequency (MHz)	Measure Level (dBuV/m)	Reading Level (dBuV)	Over Limit (dB)	Limit (dBuV/m)	Factor	Type
1		*	1574.402	1.126	8.811	-18.274	19.400	-7.685	AV

Note: Measure Level (dB μ V/m) = Reading Level (dB μ V) + Factor (dB)

Factor (dB) = Cable Loss (dB) + Antenna Factor (dB/m) - Pre_Amplifier Gain (dB)

7.5. Transmission Duration Requirements

7.5.1. Test Limit

The EUT was verified for compliance with transmission duration requirements listed below:

- A transmitter shall cease transmission within 10 seconds unless it receives an acknowledgement from the associated receiver that its transmission was received.

7.5.2. Test Procedure Used

47 CFR, Section 15.521, Section 15.519(a)(1), RSS-220 section 5.3.1(b).

7.5.3. Test Setting

The spectrum analyzer center frequency was adjusted to the EUT carrier, span set to zero and video triggered for transmission. The transmitter was activated. The transmission time was captured and shown in the associated plots.

7.5.4. Test Setup

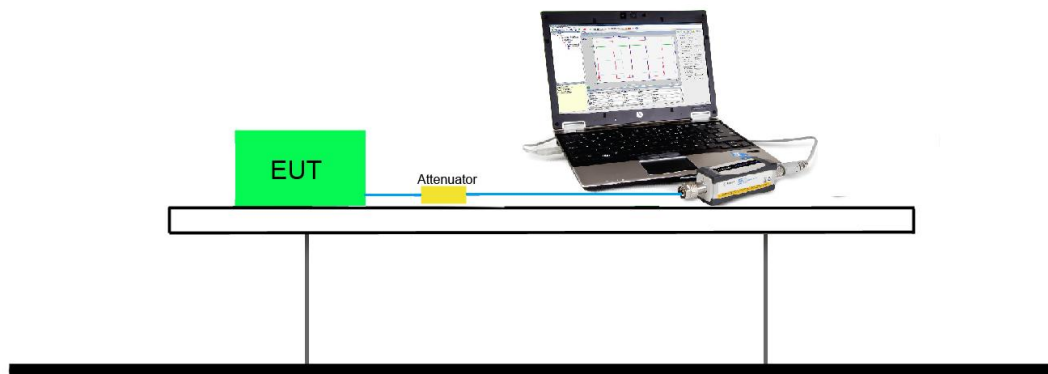

7.5.5. Test Result

Product	Remote Controller	Temperature	25°C
Test Engineer	Roy Cheng	Relative Humidity	60%
Test Site	TR3	Test Date	2017/11/09
Test Item	Transmission duration requirements		

Channel No.	Frequency (MHz)	RF transmission duration (s)	Limit (s)	Result
5	6489.6	6.642	≤ 10	Pass

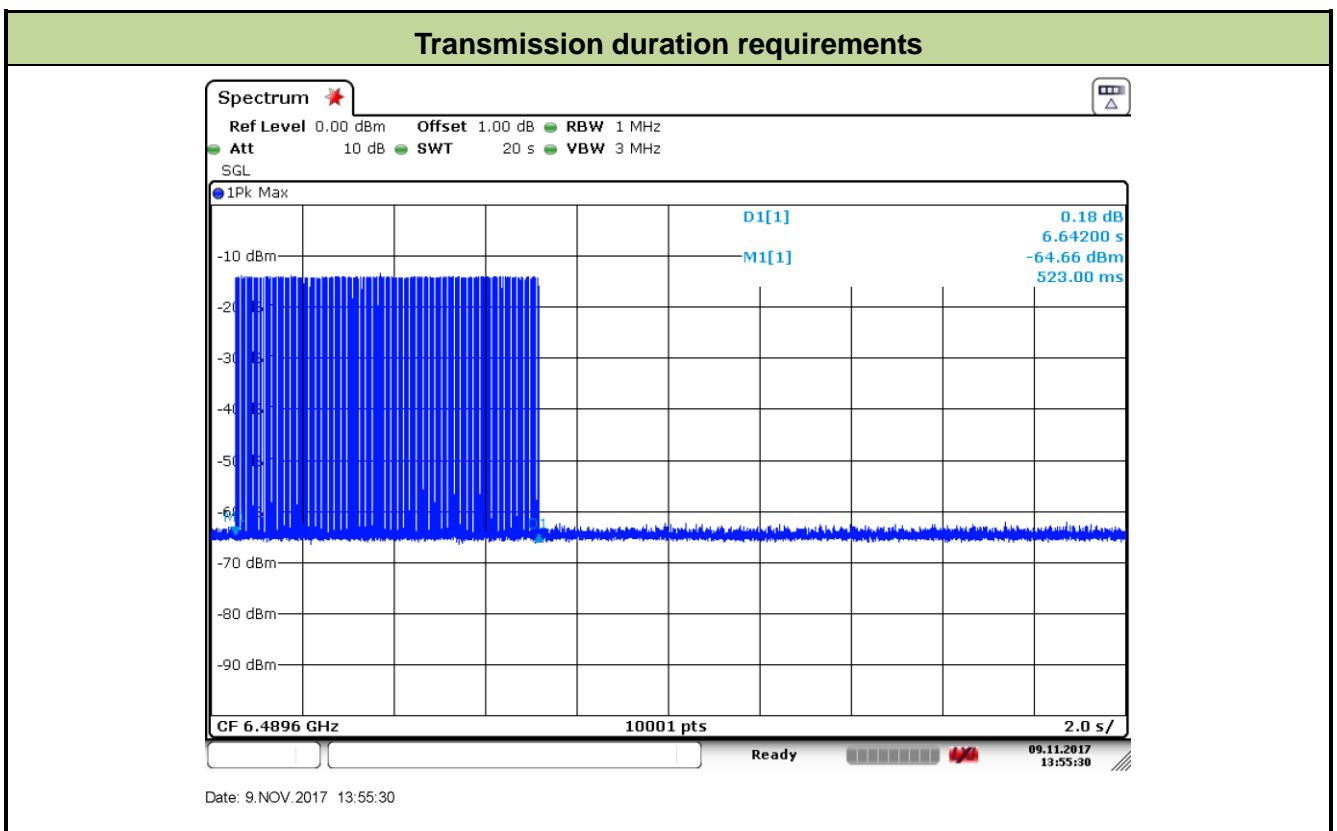

7.6. AC Conducted Emissions Measurement

7.6.1. Test Limit

FCC Part 15 Subpart C Paragraph 15.207 Limits		
Frequency (MHz)	QP (dBuV)	AV (dBuV)
0.15 - 0.50	66 - 56	56 - 46
0.50 - 5.0	56	46
5.0 - 30	60	50

Note 1: The lower limit shall apply at the transition frequencies.

Note 2: The limit decreases linearly with the logarithm of the frequency in the range 0.15MHz to 0.5MHz.

7.6.2. Test Procedure Used

47 CFR, Section 15.521(j), RSS-GEN Issue 4 section 8.8.

7.6.3. Test Setting

The radio frequency voltage that is conducted back onto the AC power line on any frequency or frequencies, within the band 150 kHz to 30 MHz, shall not exceed the limits in the following table, as measured using a 50 μ H/50 ohms line impedance stabilization network (LISN). Compliance with the provisions of this paragraph shall be based on the measurement of the radio frequency voltage between each power line and ground at the power terminal.

7.6.4. Test Setup

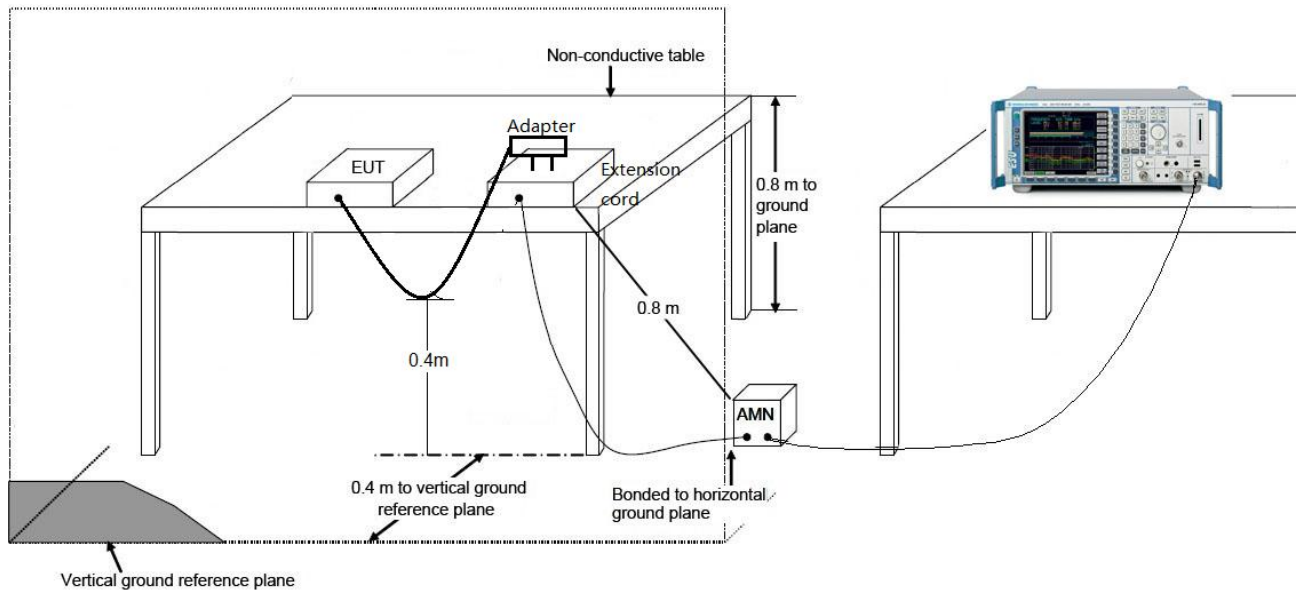

7.6.5. Test Result

Site: SR2	Time: 2017/08/09 - 20:13
Limit: FCC_Part15.207_CE_AC Power	Engineer: Bacon Dong
Probe: ENV216_101683_Filter On	Polarity: Line
EUT: Segway miniPLUS	Power: AC 120V/60Hz
Worst Case Mode: Transmit by UWB	

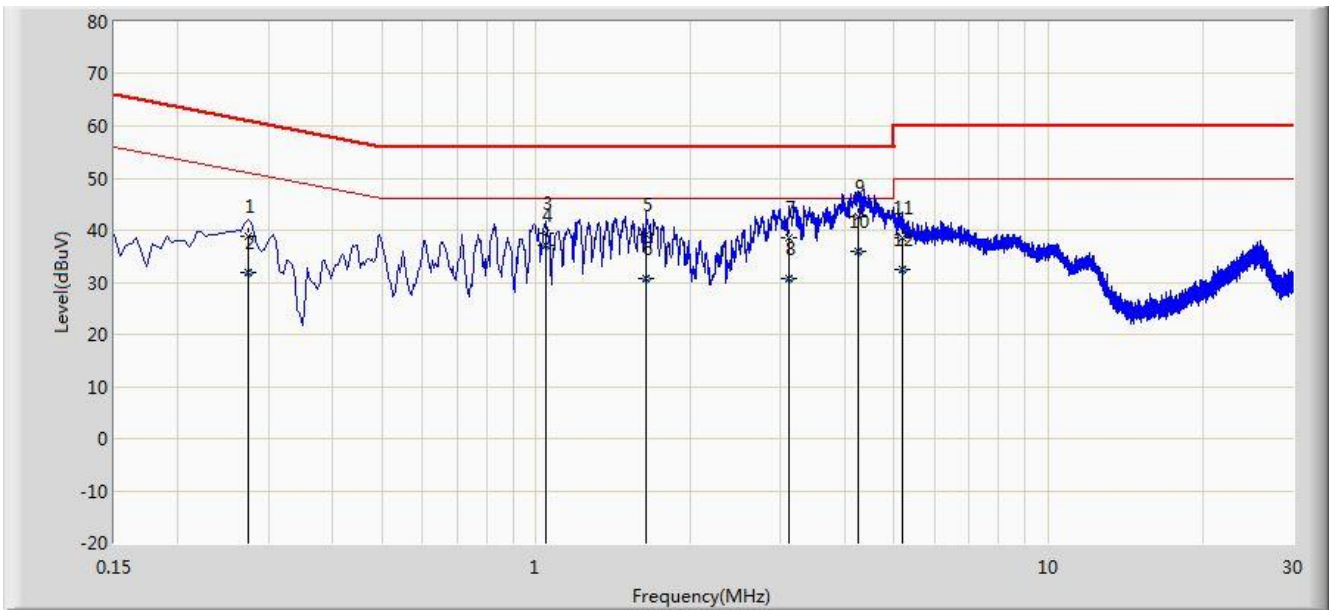

No	Flag	Mark	Frequency (MHz)	Measure Level (dBuV)	Reading Level (dBuV)	Over Limit (dB)	Limit (dBuV)	Factor (dB)	Type
1			0.274	38.949	28.965	-22.047	60.996	9.983	QP
2			0.274	31.888	21.904	-19.108	50.996	9.983	AV
3			1.046	39.545	29.638	-16.455	56.000	9.907	QP
4		*	1.046	36.988	27.081	-9.012	46.000	9.907	AV
5			1.642	39.066	29.183	-16.934	56.000	9.884	QP
6			1.642	30.777	20.893	-15.223	46.000	9.884	AV
7			3.114	38.586	28.728	-17.414	56.000	9.858	QP
8			3.114	30.633	20.775	-15.367	46.000	9.858	AV
9			4.250	42.654	32.677	-13.346	56.000	9.978	QP
10			4.250	35.973	25.996	-10.027	46.000	9.978	AV
11			5.170	38.515	28.469	-21.485	60.000	10.047	QP
12			5.170	32.527	22.480	-17.473	50.000	10.047	AV

Note: Measure Level (dBμV) = Reading Level (dBμV) + Factor (dB)

Factor (dB) = Cable Loss (dB) + LISN Factor (dB)

Site: SR2	Time: 2017/08/09 - 20:19
Limit: FCC_Part15.207_CE_AC Power	Engineer: Bacon Dong
Probe: ENV216_101683_Filter On	Polarity: Neutral
EUT: Segway miniPLUS	Power: AC 120V/60Hz
Worst Case Mode: Transmit by UWB	

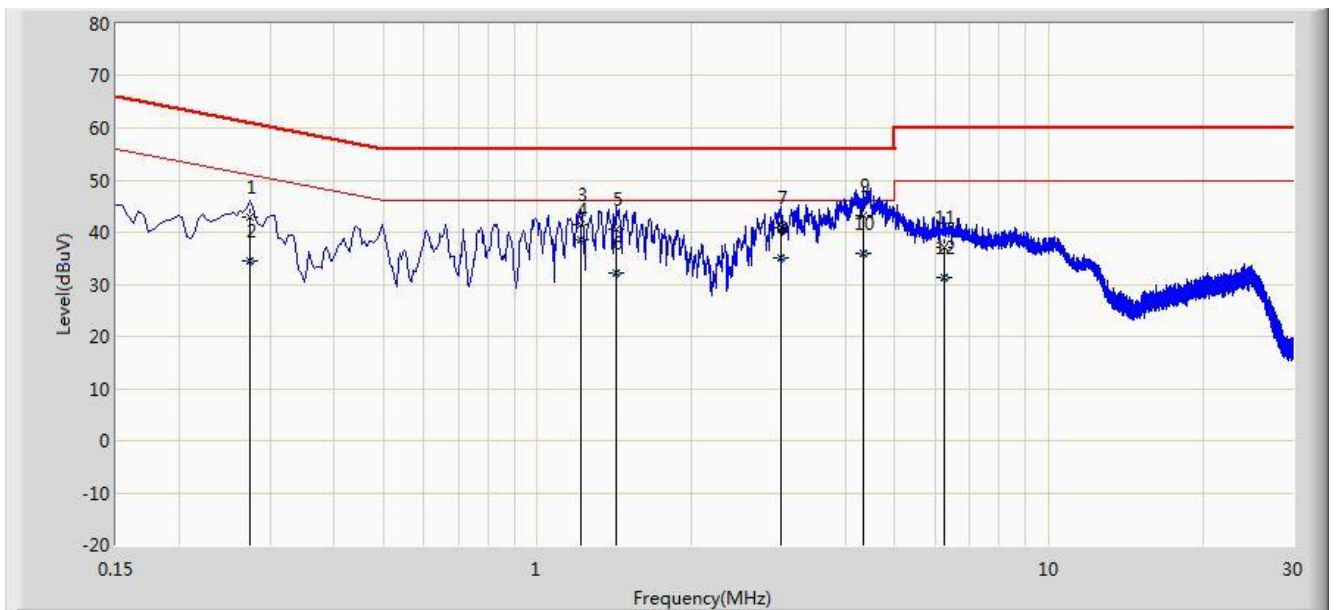

No	Flag	Mark	Frequency (MHz)	Measure Level (dBuV)	Reading Level (dBuV)	Over Limit (dB)	Limit (dBuV)	Factor (dB)	Type
1			0.274	42.798	32.779	-18.198	60.996	10.019	QP
2			0.274	34.593	24.575	-16.403	50.996	10.019	AV
3			1.214	41.464	31.562	-14.536	56.000	9.902	QP
4		*	1.214	38.495	28.594	-7.505	46.000	9.902	AV
5			1.426	40.653	30.760	-15.347	56.000	9.893	QP
6			1.426	32.163	22.271	-13.837	46.000	9.893	AV
7			2.986	40.976	31.110	-15.024	56.000	9.866	QP
8			2.986	34.939	25.073	-11.061	46.000	9.866	AV
9			4.334	43.119	33.131	-12.881	56.000	9.988	QP
10			4.334	35.835	25.846	-10.165	46.000	9.988	AV
11			6.230	37.211	27.076	-22.789	60.000	10.135	QP
12			6.230	31.222	21.087	-18.778	50.000	10.135	AV

Note: Measure Level (dBμV) = Reading Level (dBμV) + Factor (dB)

Factor (dB) = Cable Loss (dB) + LISN Factor (dB)

8. CONCLUSION

The data collected relate only the item(s) tested and show that the **Segway miniPLUS FCC ID: 2ALS8-NB5213** is in compliance with Part 15C of the FCC Rules and IC Rules.

The End