

MEASUREMENT REPORT

FCC PART 15.247 & IC RSS-247 Bluetooth

FCC ID: 2ALS8-NA2468
IC: 22636-NA2468
APPLICANT: Ninebot (Changzhou) Tech Co., Ltd.
Application Type: Certification
Product: Segway miniLITE
Model No.: N4M160
Brand Name: Segway
FCC Classification: Digital Transmission System (DTS)
FCC Rule Part(s): Part 15.247
IC Rule(s): RSS-247 Issue 2
Test Procedure(s): ANSI C63.10-2013, KDB 558074 D01v04
Test Date: July 10 ~ 21, 2017

Reviewed : Paddy Chen
(Paddy Chen)
Approved By : Chenz Ker
(Chenz Ker)



The test results relate only to the samples tested.

This equipment has been shown to be capable of compliance with the applicable technical standards as indicated in the measurement report and was tested in accordance with the measurement procedures specified in KDB 558074 D01v03r05. Test results reported herein relate only to the item(s) tested.

The test report shall not be reproduced except in full without the written approval of MRT Technology (Taiwan) Co., Ltd.

Revision History

Report No.	Version	Description	Issue Date	Note
1707TW0107-U1	Rev. 01	Initial Report	08-12-2017	Invalid
1707TW0107-U1	Rev. 02	Revise the Manufacture	08-30-2017	Valid

CONTENTS

Description	Page
1. INTRODUCTION	6
1.1. Scope	6
1.2. MRT Test Location	6
2. PRODUCT INFORMATION	7
2.1. Feature of Equipment under Test	7
2.2. Working Frequencies	7
2.3. Device Capabilities	8
2.4. Test Configuration	8
2.5. EMI Suppression Device(s)/Modifications	8
2.6. Labeling Requirements	8
2.7. Test Software	8
3. DESCRIPTION OF TEST	9
3.1. Evaluation Procedure	9
3.2. AC Line Conducted Emissions	9
3.3. Radiated Emissions	10
4. ANTENNA REQUIREMENTS	11
5. TEST EQUIPMENT CALIBRATION DATE	12
6. MEASUREMENT UNCERTAINTY	13
7. TEST RESULT	14
7.1. Summary	14
7.2. 6dB Bandwidth Measurement	15
7.2.1. Test Limit	15
7.2.2. Test Procedure used	15
7.2.3. Test Setting	15
7.2.4. Test Setup	15
7.2.5. Test Result	16
7.3. Output Power Measurement	17
7.3.1. Test Limit	17
7.3.2. Test Procedure Used	17
7.3.3. Test Setting	17
7.3.4. Test Setup	17
7.3.5. Test Result of Output Power	18
7.4. Power Spectral Density Measurement	19

7.4.1.	Test Limit	19
7.4.2.	Test Procedure Used	19
7.4.3.	Test Setting	19
7.4.4.	Test Setup.....	19
7.4.5.	Test Result.....	20
7.5.	Conducted Band Edge and Out-of-Band Emissions.....	21
7.5.1.	Test Limit	21
7.5.2.	Test Procedure Used	21
7.5.3.	Test Settintg	21
7.5.4.	Test Setup.....	22
7.5.5.	Test Result.....	23
7.6.	Radiated Spurious Emission Measurement	25
7.6.1.	Test Limit	25
7.6.2.	Test Procedure Used	25
7.6.3.	Test Setting	25
7.6.4.	Test Setup.....	27
7.6.5.	Test Result.....	29
7.7.	Radiated Restricted Band Edge Measurement	34
7.7.1.	Test Result.....	34
7.8.	AC Conducted Emissions Measurement.....	42
7.8.1.	Test Limit	42
7.8.2.	Test Setup.....	42
7.8.3.	Test Result.....	43
8.	CONCLUSION.....	45

§2.1033 General Information

Applicant:	Ninebot (Changzhou) Tech Co., Ltd.
Applicant Address:	16F-17F, Block A, Building 3, Changwu Mid Road 18#, Wujin Dist., Changzhou, Jiangsu, China.
Manufacturer:	Ninebot (Tianjin) Tech Co., Ltd.
Manufacturer Address:	Building 14, No. 3, Tianrui Road, Auto Industrial Park, Wuqing Dist., Tianjin, China.
Test Site:	MRT Technology (Taiwan) Co., Ltd
Test Site Address:	No. 38, Fuxing Second Rd., Guishan Dist., Taoyuan City 333, Taiwan (R.O.C)
MRT Registration No.:	153292
Test Device Serial No.:	N/A <input type="checkbox"/> Production <input checked="" type="checkbox"/> Pre-Production <input type="checkbox"/> Engineering

Test Facility / Accreditations

Measurements were performed at MRT Laboratory located in Fuxing Rd., Taoyuan, Taiwan (R.O.C)

- MRT facility is a FCC registered (Reg. No. 153292) test facility with the site description report on file and is designated by the FCC as an Accredited Test Film.
- MRT facility is an IC registered (MRT Reg. No. 21723-1) test laboratory with the site description on file at Industry Canada.
- MRT Lab is accredited to ISO 17025 by the American Association for Laboratory Accreditation (TAF) under the American Association for Laboratory Accreditation Program (TAF Cert. No. 3261) in EMC, Telecommunications and Radio testing for FCC, Industry Taiwan, EU and TELEC Rules.

1. INTRODUCTION

1.1. Scope

Measurement and determination of electromagnetic emissions (EMC) of radio frequency devices including intentional and/or unintentional radiators for compliance with the technical rules and regulations of the Federal Communications Commission and the Industry Canada Certification and Engineering Bureau.

1.2. MRT Test Location

The map below shows the location of the MRT LABORATORY, its proximity to the Taoyuan City. These measurement tests were conducted at the MRT Technology (Taiwan) Co., Ltd. Facility located at No.38, Fuxing 2nd Rd., Guishan Dist., Taoyuan City 33377, Taiwan (R.O.C).

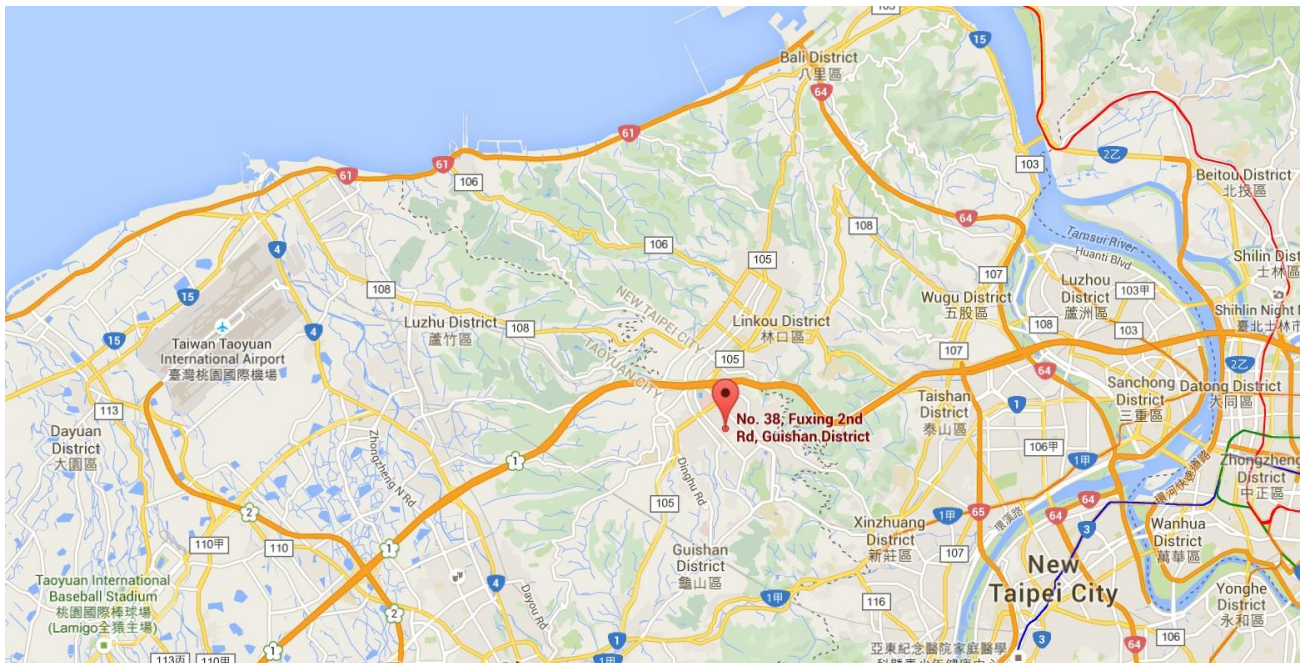

2. PRODUCT INFORMATION

2.1. Feature of Equipment under Test

Product Name	Segway miniLITE
Model No.	N4M160
Brand Name:	Segway
Bluetooth Version	v4.1 (BLE Only)
Bluetooth Frequency	2402~2480MHz
Data Rate	1Mbps(GFSK)
Antenna Gain	5.0dBi

2.2. Working Frequencies

Channel List for BLE

Channel	Frequency	Channel	Frequency	Channel	Frequency
00	2402 MHz	01	2404 MHz	02	2406 MHz
03	2408 MHz	04	2410 MHz	05	2412 MHz
06	2414 MHz	07	2416 MHz	08	2418 MHz
09	2420 MHz	10	2422 MHz	11	2424 MHz
12	2426 MHz	13	2428 MHz	14	2430 MHz
15	2432 MHz	16	2434 MHz	17	2436 MHz
18	2438 MHz	19	2440 MHz	20	2442 MHz
21	2444 MHz	22	2446 MHz	23	2448 MHz
24	2450 MHz	25	2452 MHz	26	2454 MHz
27	2456 MHz	28	2458 MHz	29	2460 MHz
30	2462 MHz	31	2464 MHz	32	2466 MHz
33	2468 MHz	34	2470 MHz	35	2472 MHz
36	2474 MHz	37	2476 MHz	38	2478 MHz
39	2480 MHz	--	--	--	--

2.3. Device Capabilities

This device contains the following capabilities:

Bluetooth (v4.1) (BLE Only).

2.4. Test Configuration

The **Segway miniLITE** was tested per the guidance of KDB 558074 D01v04. ANSI C63.10-2013 was used to reference the appropriate EUT setup for radiated spurious emissions testing and AC line conducted testing.

2.5. EMI Suppression Device(s)/Modifications

No EMI suppression device(s) were added and/or no modifications were made during testing.

2.6. Labeling Requirements

Per 2.1074 & 15.19; Docket 95-19

The label shall be permanently affixed at a conspicuous location on the device; instruction manual or pamphlet supplied to the user and be readily visible to the purchaser at the time of purchase.

However, when the device is so small wherein placement of the label with specified statement is not practical, only the FCC ID must be displayed on the device per Section 15.19(a)(5). Please see attachment for FCC ID label and label location.

2.7. Test Software

The test utility software used during testing was “nRFgo Studio”.

3. DESCRIPTION OF TEST

3.1. Evaluation Procedure

The measurement procedures described in the American National Standard for Testing Unlicensed Wireless Devices (ANSI C63.10-2013), and the guidance provided in KDB 558074 D01v04 were used in the measurement of the **Segway miniLITE**.

Deviation from measurement procedure.....None

3.2. AC Line Conducted Emissions

The line-conducted facility is located inside an 8'x4'x4' shielded enclosure. A 1m x 2m wooden table 80cm high is placed 40cm away from the vertical wall and 80cm away from the sidewall of the shielded room. Two 10kHz-30MHz, 50Ω/50uH Line-Impedance Stabilization Networks (LISNs) are bonded to the shielded room floor. Power to the LISNs is filtered by external high-current high-insertion loss power line filters. These filters attenuate ambient signal noise from entering the measurement lines. These filters are also bonded to the shielded enclosure.

The EUT is powered from one LISN and the support equipment is powered from the second LISN. All interconnecting cables more than 1 meter were shortened to a 1 meter length by non-inductive bundling (serpentine fashion) and draped over the back edge of the test table. All cables were at least 40cm above the horizontal reference ground-plane. Power cables for support equipment were routed down to the second LISN while ensuring that that cables were not draped over the second LISN.

Sufficient time for the EUT, support equipment, and test equipment was allowed in order for them to warm up to their normal operating condition. The RF output of the LISN was connected to the receiver and exploratory measurements were made to determine the frequencies producing the maximum emission from the EUT. The receiver was scanned from 150kHz to 30MHz. The detector function was set to peak mode for exploratory measurements while the bandwidth of the analyzer was set to 9kHz. The EUT, support equipment, and interconnecting cables were arranged and manipulated to maximize each emission. Each emission was also maximized by varying: power lines, the mode of operation or data exchange speed, or support equipment whichever determined the worst-case emission. Once the worst case emissions have been identified, the one EUT cable configuration/arrangement and mode of operation that produced these emissions were used for final measurements on the same test site. The analyzer is set to CISPR quasi-peak and average detectors with a 9kHz resolution bandwidth for final measurements.

An extension cord was used to connect to a single LISN which powered by EUT. The extension cord was calibrated with LISN, the impedance and insertion loss are compliance with the requirements as stated in ANSI C63.10-2013.

Line conducted emissions test results are shown in Section 7.8.

3.3. Radiated Emissions

The radiated test facilities consisted of an indoor 3 meter semi-anechoic chamber used for final measurements and exploratory measurements, when necessary. The measurement area is contained within the semi-anechoic chamber which is shielded from any ambient interference. For measurements above 1GHz absorbers are arranged on the floor between the turn table and the Antenna mast in such a way so as to maximize the reduction of reflections. For measurements below 1GHz, the absorbers are removed. A MF Model 210SS turntable is used for radiated measurement. It is a continuously rotatable, remote controlled, metallic turntable and 2 meters (6.56 ft.) in diameter. The turn table is flush with the raised floor of the chamber in order to maintain its function as a ground plane. An 80cm high PVC support structure is placed on top of the turntable. For all measurements, the spectrum was scanned through all EUT azimuths and from 1 to 4 meter receive Antenna height using a broadband Antenna from 30MHz up to the upper frequency shown in 15.33(b)(1) depending on the highest frequency generated or used in the device or on which the device operates or tunes. For frequencies above 1GHz, linearly polarized double ridge horn Antennas were used. For frequencies below 30MHz, a calibrated loop Antenna was used. When exploratory measurements were necessary, they were performed at 1 meter test distance inside the semi-anechoic chamber using broadband Antennas, broadband amplifiers, and spectrum analyzers to determine the frequencies and modes producing the maximum emissions. Sufficient time for the EUT, support equipment, and test equipment was allowed in order for them to warm up to their normal operating condition. The test set-up for frequencies below 1GHz was placed on top of the 0.8 meter high, 1 x 1.5 meter table; and test set-up for frequencies 1-40GHz was placed on top of the 1.5 meter high, 1 x 1.5 meter table. The EUT, support equipment, and interconnecting cables were arranged and manipulated to maximize each emission. Appropriate precaution was taken to ensure that all emissions from the EUT were maximized and investigated. The system configuration, clock speed, mode of operation or video resolution, if applicable, turntable azimuth, and receive Antenna height was noted for each frequency found.

Final measurements were made in the semi-anechoic chamber using calibrated, linearly polarized broadband and horn Antennas. The test setup was configured to the setup that produced the worst case emissions. The spectrum analyzer was set to investigate all frequencies required for testing to compare the highest radiated disturbances with respect to the specified limits. The turntable containing the EUT was rotated through 360 degrees and the height of the receive Antenna was varied 1 to 4 meters and stopped at the azimuth and height producing the maximum emission. Each emission was maximized by changing the orientation of the EUT through three orthogonal planes and changing the polarity of the receive Antenna, whichever produced the worst-case emissions. According to 3dB Beam-Width of horn Antenna, the horn Antenna should be always directed to the EUT when rising height.

4. ANTENNA REQUIREMENTS

Excerpt from §15.203 of the FCC Rules/Regulations:

“An intentional radiator antenna shall be designed to ensure that no antenna other than that furnished by the responsible party can be used with the device. The use of a permanently attached antenna or of an antenna that uses a unique coupling to the intentional radiator shall be considered sufficient to comply with the provisions of this section.”

- The antenna of the **Segway miniLITE** is **permanently attached**.
- There are no provisions for connection to an external antenna.

Conclusion:

The **Segway miniLITE** unit complies with the requirement of §15.203.

5. TEST EQUIPMENT CALIBRATION DATE

Conducted Emissions

Instrument	Manufacturer	Type No.	Asset No.	Cali. Interval	Cali. Due Date
EMI Test Receiver	R&S	ESR3	MRTTWA00045	1 year	2018/03/17
Two-Line V-Network	R&S	ENV216	MRTTWA00019	1 year	2018/03/23
Two-Line V-Network	R&S	ENV216	MRTTWA00020	1 year	2018/03/23
Temperature/Humidity Meter	TFA	35.1078.10.IT	MRTTWA00033	1 year	2018/06/08

Radiated Emissions

Instrument	Manufacturer	Type No.	Asset No.	Cali. Interval	Cali. Due Date
Signal Analyzer	R&S	FSV40	MRTTWA00007	1 year	2018/03/02
EMI Test Receiver	R&S	ESR3	MRTTWA00009	1 year	2018/03/16
Broadband Preamplifier	SCHWARZBECK	BBV 9718	MRTTWA00005	1 year	2018/04/06
Broadband Amplifier	SCHWARZBECK	BBV 9721	MRTTWA00006	1 year	2018/04/06
Active Loop Antenna	SCHWARZBECK	FMZB 1519B	MRTTWA00002	1 year	2018/04/06
Broadband TRILOG Antenna	SCHWARZBECK	VULB 9162	MRTTWA00001	1 year	2018/04/06
Broadband Hornantenna	SCHWARZBECK	BBHA 9120D	MRTTWA00003	1 year	2018/04/06
Breitband Hornantenna	SCHWARZBECK	BBHA 9170	MRTTWA00004	1 year	2018/04/06
Temperature/Humidity Meter	TFA	35.1078.10.IT	MRTTWA00033	1 year	2018/06/08

Conducted Test Equipment

Instrument	Manufacturer	Type No.	Asset No.	Cali. Interval	Cali. Due Date
EXA Signal Analyzer	KEYSIGHT	N9010A	MRTTWA00012	1 year	2018/07/10
X-Series USB Peak and Average Power Sensor	KEYSIGHT	U2021XA	MRTTWA00014	1 year	2018/03/18
X-Series USB Peak and Average Power Sensor	KEYSIGHT	U2021XA	MRTTWA00015	1 year	2018/03/18
Programmable Temperature & Humidity Chamber	TEN BILLION	TTH-B3UP	MRTTWA00036	1 year	2018/05/11
Temperature/Humidity Meter	TFA	35.1078.10.IT	MRTTWA00033	1 year	2018/06/08

Software	Version	Function
EMI Software	V3	EMI Test Software

6. MEASUREMENT UNCERTAINTY

Where relevant, the following test uncertainty levels have been estimated for tests performed on the EUT as specified in CISPR 16-4-2. This uncertainty represents an expanded uncertainty expressed at approximately the 95% confidence level using a coverage factor of $k = 2$.

AC Conducted Emission Measurement
Measuring Uncertainty for a Level of Confidence of 95% ($U=2Uc(y)$): 150kHz~30MHz: 3.46dB
Radiated Emission Measurement
Measuring Uncertainty for a Level of Confidence of 95% ($U=2Uc(y)$): 9kHz ~ 1GHz: 4.18dB 1GHz ~ 25GHz: 4.76dB
Output Power - TR3
Measuring Uncertainty for a Level of Confidence of 95% ($U=2Uc(y)$): 1.13dB
Power Spectrum Density - TR3
Measuring Uncertainty for a Level of Confidence of 95% ($U=2Uc(y)$): 1.15dB
Occupied Bandwidth - TR3
Measuring Uncertainty for a Level of Confidence of 95% ($U=2Uc(y)$): 0.28%

7. TEST RESULT

7.1. Summary

Company Name: Ninebot (Changzhou) Tech Co., Ltd.
FCC ID: 2ALS8-NA2468
IC: 22636-NA2468
FCC Classification: Digital Transmission System (DTS)
Data Rate(s) Tested: 1Mbps(GFSK) (BLE)

FCC Section(s)	IC Section(s)	Test Description	Test Limit	Test Condition	Test Result	Reference
15.247(a)(2)	RSS-247 [5.2]	6dB Bandwidth	$\geq 500\text{kHz}$	Conducted	Pass	Section 7.2
15.247(b)(3)	RSS-247 [5.4(4)]	Output Power	$\leq 30\text{dBm}$		Pass	Section 7.3
15.247(e)	RSS-247 [5.2]	Power Spectral Density	$\leq 8\text{dBm}/3\text{kHz}$		Pass	Section 7.4
15.247(d)	RSS-247 [5.5]	Band Edge / Out-of-Band Emissions	$\geq 20\text{dBc(Peak)}$		Pass	Section 7.5
15.205 15.209	RSS-247 [5.5]	General Field Strength Limits (Restricted Bands and Radiated Emission Limits)	Emissions in restricted bands must meet the radiated limits detailed in 15.209	Radiated	Pass	Section 7.6 & 7.7
15.207	RSS-Gen [8.8]	AC Conducted Emissions 150kHz - 30MHz	< FCC 15.207 limits	Line Conducted	Pass	Section 7.8

Notes: The analyzer plots shown in this section were all taken with a correction table loaded into the analyzer. The correction table was used to account for the losses of the cables and attenuators used as part of the system to connect the EUT to the analyzer at all frequencies of interest.

7.2. 6dB Bandwidth Measurement

7.2.1. Test Limit

The minimum 6dB bandwidth shall be at least 500 kHz.

7.2.2. Test Procedure used

KDB 558074 D01v04 - Section 8.2 Option 2

7.2.3. Test Setting

1. The Spectrum's automatic bandwidth measurement capability was used to perform the 6dB bandwidth measurement. The "X" dB bandwidth parameter was set to $X = 6$. The bandwidth measurement was not influenced by any intermediate power nulls in the fundamental emission.
2. Set RBW = 100 kHz
3. VBW $\geq 3 \times$ RBW
4. Detector = Peak
5. Trace mode = max hold
6. Sweep = auto couple
7. Allow the trace was allowed to stabilize

7.2.4. Test Setup

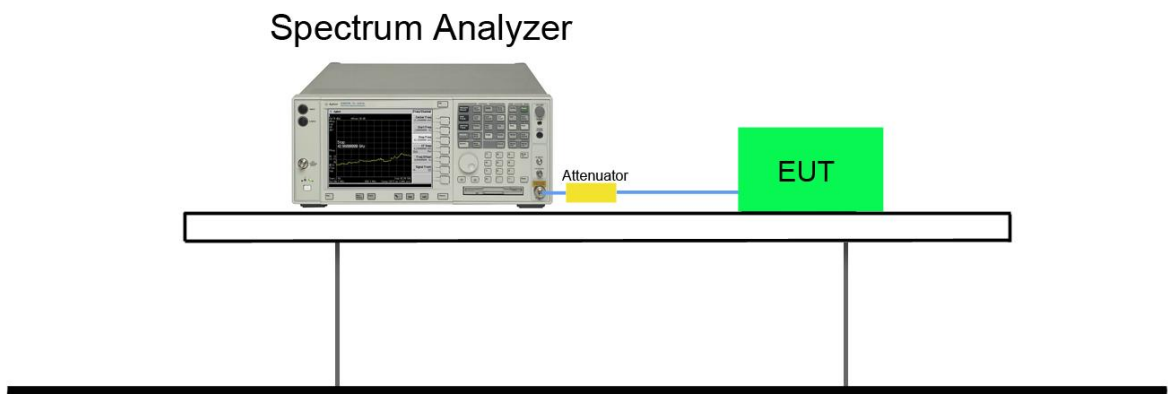

7.2.5. Test Result

Test Mode	Data Rate (Mbps)	Channel No.	Frequency (MHz)	6dB Bandwidth (MHz)	Limit (MHz)	Result
BLE	1	00	2402	0.68	≥ 0.5	Pass
BLE	1	19	2440	0.68	≥ 0.5	Pass
BLE	1	39	2480	0.69	≥ 0.5	Pass

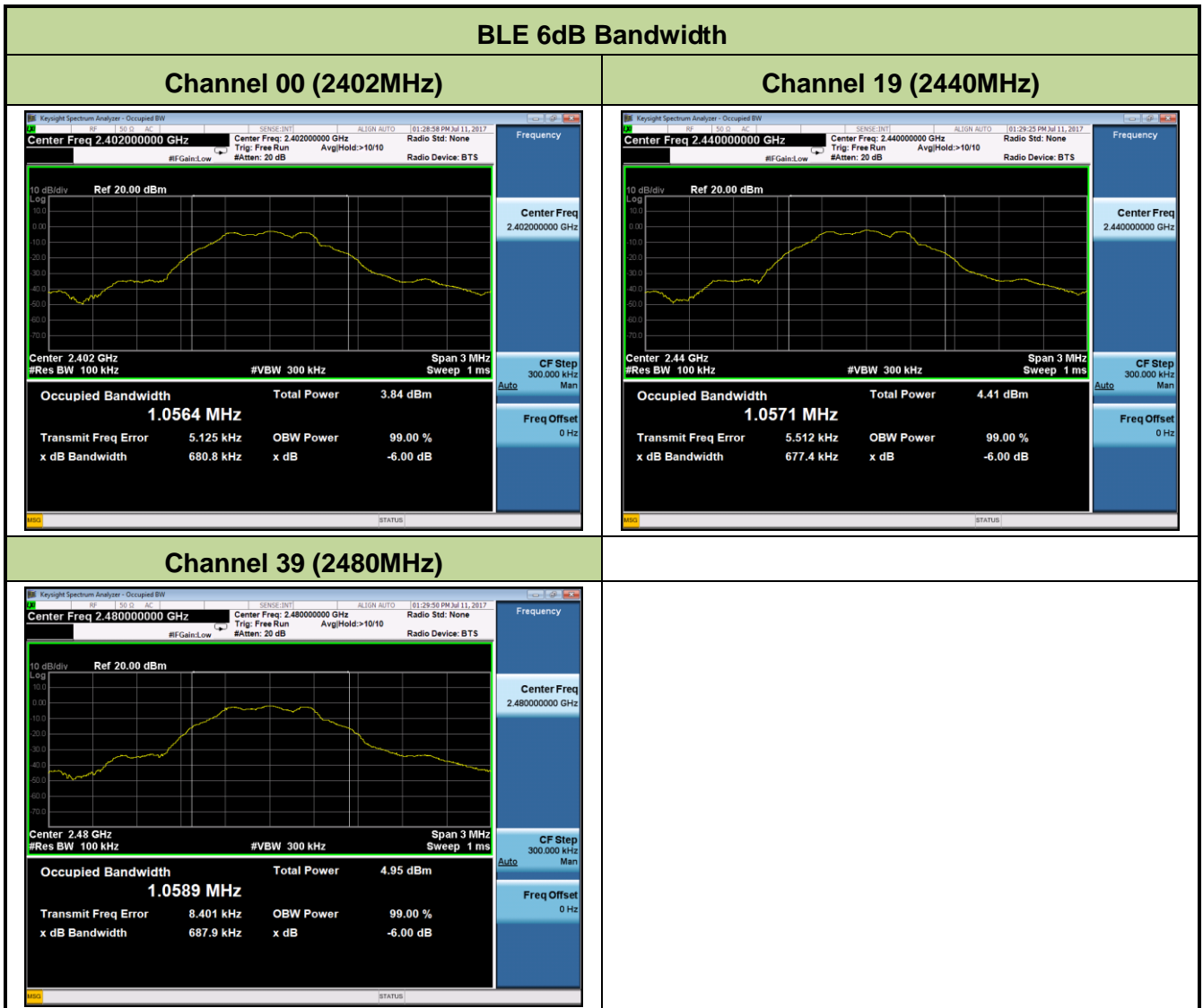

7.3. Output Power Measurement

7.3.1. Test Limit

The maximum out power shall be less 1 Watt (30dBm).

7.3.2. Test Procedure Used

KDB 558074 D01v04 - Section 9.1.2 PKPM1 - Peak Power Method

7.3.3. Test Setting

Method PKPM1 (Peak Power Measurement of Signals with DTS BW \leq 50MHz)

Peak power measurements were performed only when the EUT was transmitting at its maximum power control level using a broadband power meter with a pulse sensor. The pulse sensor employs a VBW = 50MHz so this method was only used for signals whose DTS bandwidth was less than or equal to 50MHz.

7.3.4. Test Setup

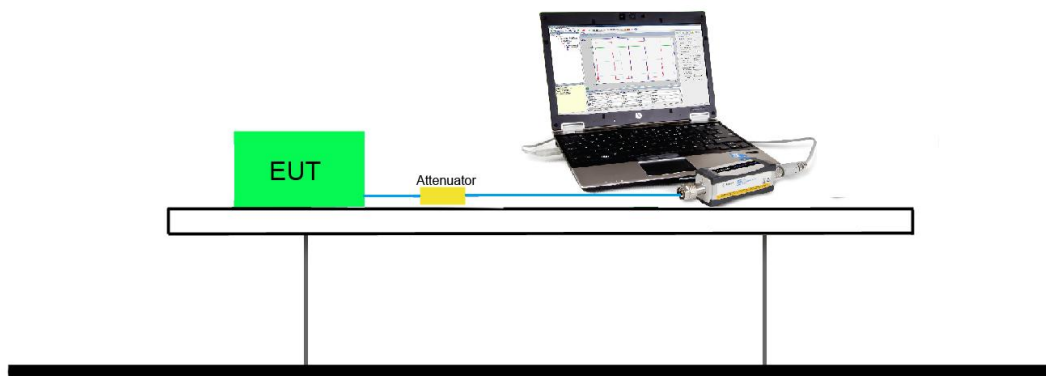

7.3.5. Test Result of Output Power

Test Result of Peak Output Power

Test Mode	Data Rate (Mbps)	Channel No.	Frequency (MHz)	Peak Power (dBm)	Limit (dBm)	Result
BLE	1	00	2402	-2.24	≤ 30	Pass
BLE	1	19	2440	-1.77	≤ 30	Pass
BLE	1	39	2480	-1.21	≤ 30	Pass

Note: The Maximum EIRP = $-1.21\text{dBm} + 5\text{dBi} = 3.79\text{dBm} < 36\text{dBm}$, so the EIRP was not shown in the report.

Test Result of Average Output Power (Reporting Only)

Test Mode	Data Rate (Mbps)	Channel No.	Frequency (MHz)	Average Power (dBm)	Limit (dBm)	Result
BLE	1	00	2402	-2.83	≤ 30	Pass
BLE	1	19	2440	-2.29	≤ 30	Pass
BLE	1	39	2480	-1.70	≤ 30	Pass

7.4. Power Spectral Density Measurement

7.4.1. Test Limit

The maximum permissible power spectral density is 8dBm in any 3 kHz band.

7.4.2. Test Procedure Used

KDB 558074 D01v04 - Section 10.2 Method PKPSD

7.4.3. Test Setting

1. Analyzer was set to the center frequency of the DTS channel under investigation
2. Span = 1.5 times the DTS channel bandwidth
3. RBW = 3kHz
4. VBW = 10kHz
5. Detector = peak
6. Sweep time = auto couple
7. Trace mode = max hold
8. Trace was allowed to stabilize

7.4.4. Test Setup

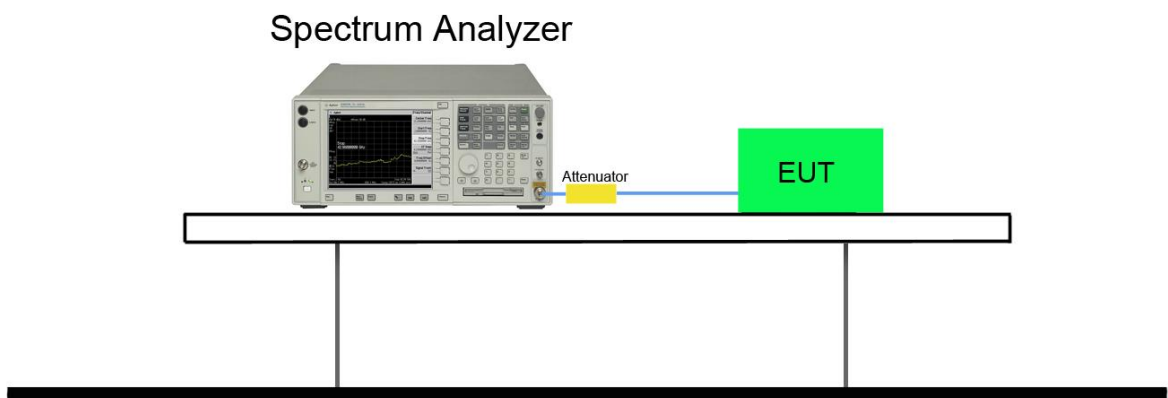

7.4.5. Test Result

Test Mode	Data Rate (Mbps)	Channel No.	Frequency (MHz)	PSD Result (dBm / 3kHz)	Limit (dBm / 3kHz)	Result
BLE	1	00	2402	-16.38	≤ 8	Pass
BLE	1	19	2440	-16.03	≤ 8	Pass
BLE	1	39	2480	-14.17	≤ 8	Pass

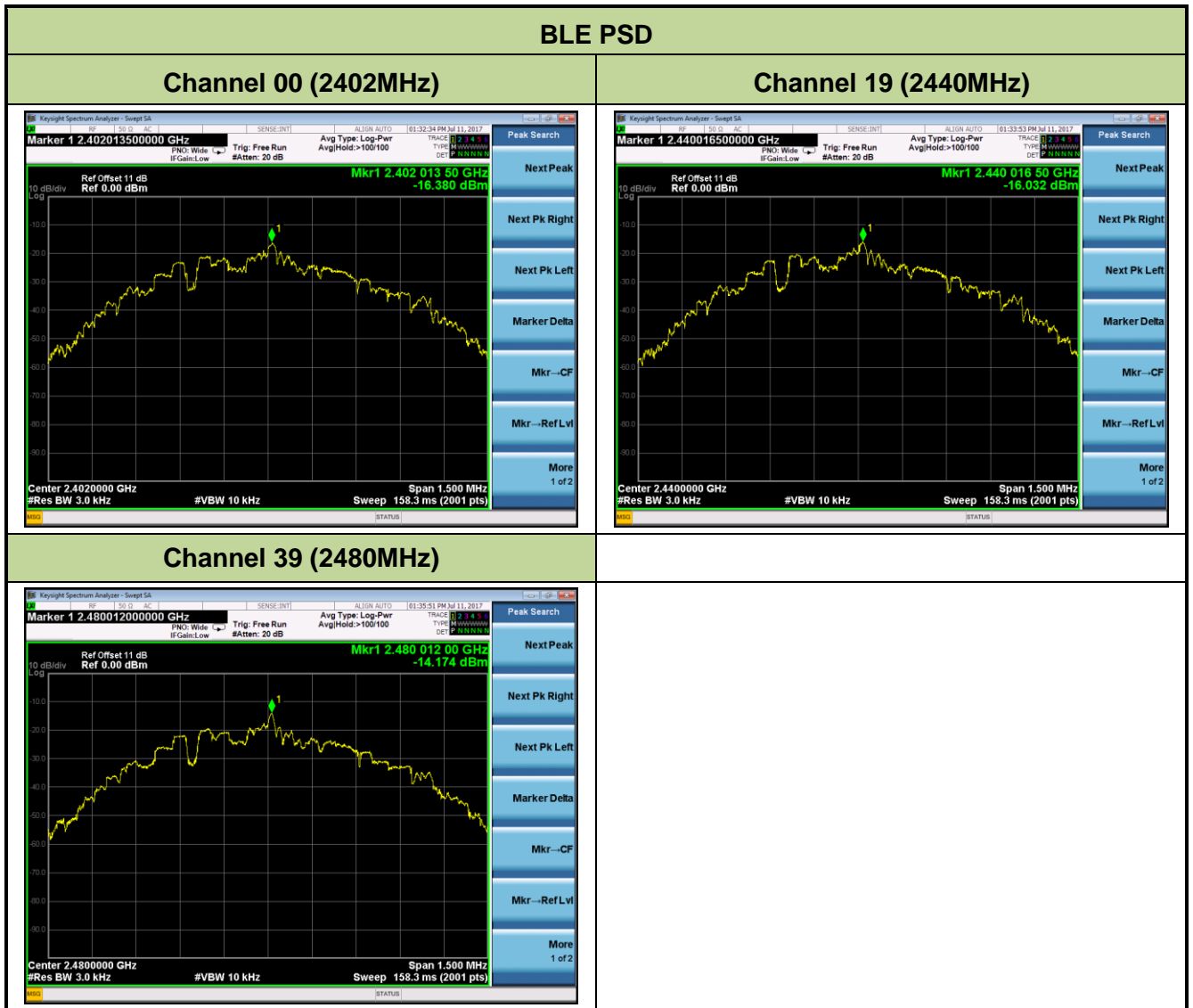

7.5. Conducted Band Edge and Out-of-Band Emissions

7.5.1. Test Limit

The limit for out-of-band spurious emissions at the band edge is 20dB below the fundamental emission level, as determined from the in-band power measurement of the DTS channel performed in a 100kHz bandwidth per the PSD procedure.

7.5.2. Test Procedure Used

KDB 558074 D01v04 - Section 11.2 & Section 11.3

7.5.3. Test Setting

Reference level measurement

1. Set instrument center frequency to DTS channel center frequency
2. Set the span to ≥ 1.5 times the DTS bandwidth
3. Set the RBW = 100 kHz
4. Set the VBW $\geq 3 \times$ RBW
5. Detector = peak
6. Sweep time = auto couple
7. Trace mode = max hold
8. Allow trace to fully stabilize

Emission level measurement

Set the center frequency and span to encompass frequency range to be measured

RBW = 100kHz

VBW = 300kHz

Detector = Peak

Number of sweep points $\geq 2 \times$ Span/RBW

Trace mode = max hold

Sweep time = auto couple

The trace was allowed to stabilize

7.5.4. Test Setup

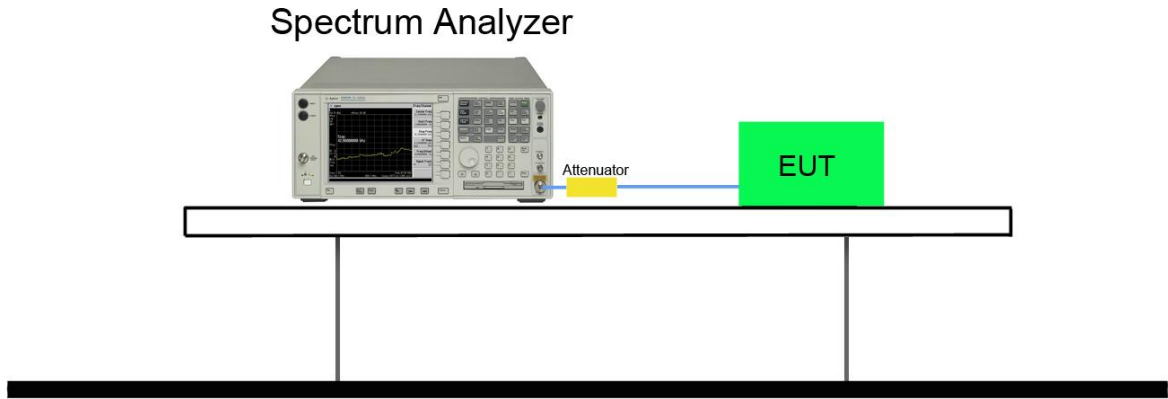

7.5.5. Test Result

Test Mode	Data Rate (Mbps)	Channel No.	Frequency (MHz)	Limit	Result
BLE	1	00	2402	20dBc	Pass
BLE	1	19	2440	20dBc	Pass
BLE	1	39	2480	20dBc	Pass

BLE Out-of-Band Emissions

Channel 00 (2402MHz)

100kHz PSD reference Level

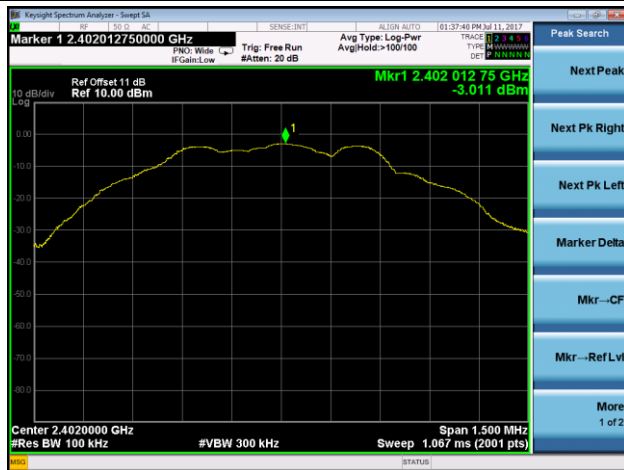

Low Band Edge



Spurious Emission 30MHz ~ 25GHz

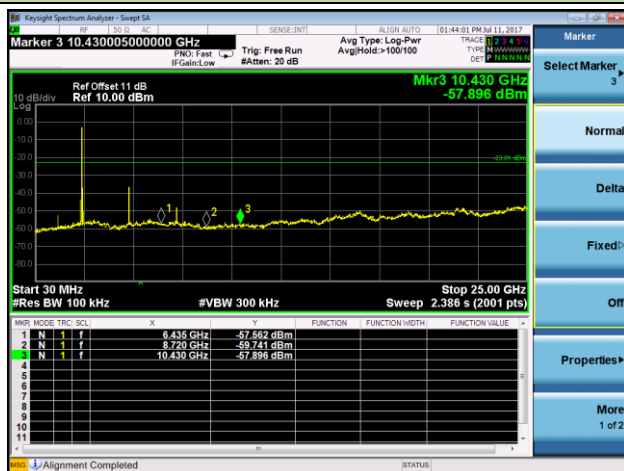

Channel 19 (2440MHz)

100kHz PSD reference Level



Spurious Emission 30MHz ~ 25GHz

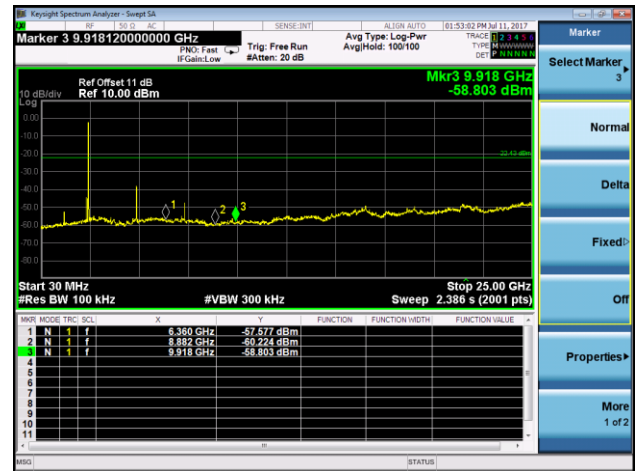

Channel 39 (2480MHz)

100kHz PSD reference Level



High Band Edge

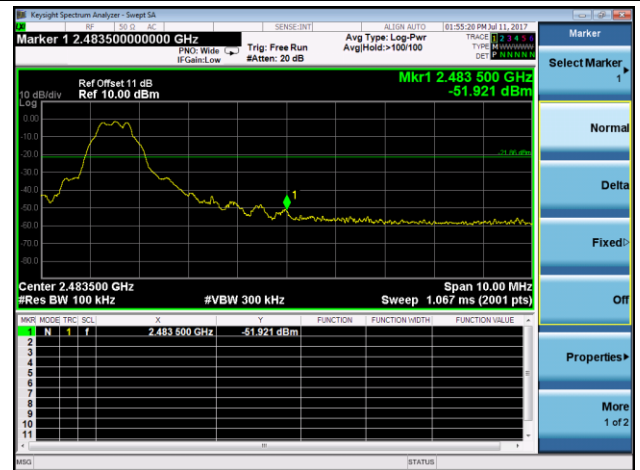

Spurious Emission 30MHz ~ 25GHz

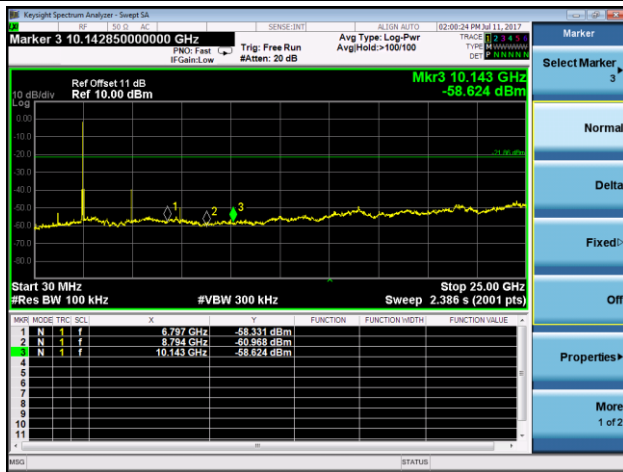

7.6. Radiated Spurious Emission Measurement

7.6.1. Test Limit

All out of band emissions appearing in a restricted band as specified in Section 15.205 of the Title 47 CFR must not exceed the limits shown in Table per Section 15.209.

FCC Part 15 Subpart C Paragraph 15.209		
Frequency [MHz]	Field Strength [uV/m]	Measured Distance [Meters]
0.009 - 0.490	2400/F (kHz)	300
0.490 - 1.705	24000/F (kHz)	30
1.705 - 30	30	30
30 - 88	100	3
88 - 216	150	3
216 - 960	200	3
Above 960	500	3

7.6.2. Test Procedure Used

KDB 558074 D01v04 - Section 12.2.3 (quasi-peak measurements)

KDB 558074 D01v04 - Section 12.2.4 (peak power measurements)

KDB 558074 D01v04 - Section 12.2.5 (average power measurements)

7.6.3. Test Setting

Peak Field Strength Measurements per Section 12.2.4 of KDB 558074 D01v04

1. Analyzer center frequency was set to the frequency of the radiated spurious emission of interest
2. RBW = as specified in Table 1
3. VBW = 3MHz
4. Detector = peak
5. Sweep time = auto couple

6. Trace mode = max hold
7. Trace was allowed to stabilize

Table 1 - RBW as a function of frequency

Frequency	RBW
9 ~ 150 kHz	200 ~ 300 Hz
0.15 ~ 30 MHz	9 ~ 10 kHz
30 ~ 1000 MHz	100 ~ 120 kHz
> 1000 MHz	1 MHz

Average Field Strength Measurements per Section 12.2.4 of KDB 558074 D01v04

1. Analyzer center frequency was set to the frequency of the radiated spurious emission of interest
2. RBW = 1MHz
3. VBW $\geq 1/T$
4. De As an alternative, the instrument may be set to linear detector mode. Ensure that video filtering is applied in linear voltage domain (rather than in a log or dB domain). Some instruments require linear display mode in order to accomplish this. Others have a setting for Average-VBW Type, which can be set to "Voltage" regardless of the display mode
5. Detector = Peak
6. Sweep time = auto
7. Trace mode = max hold
8. Allow max hold to run for at least 50 times (1/duty cycle) traces

7.6.4. Test Setup

9kHz ~ 30MHz Test Setup:

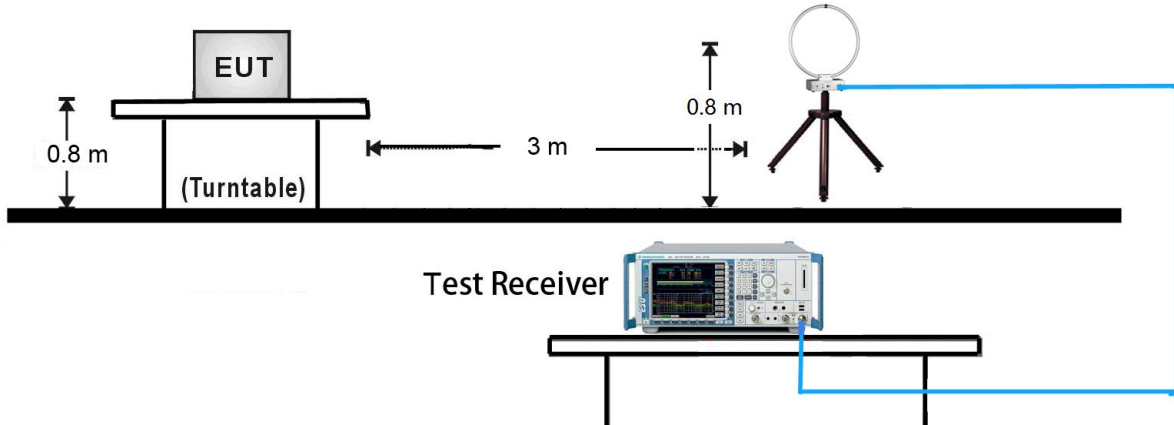

30MHz ~ 1GHz Test Setup:

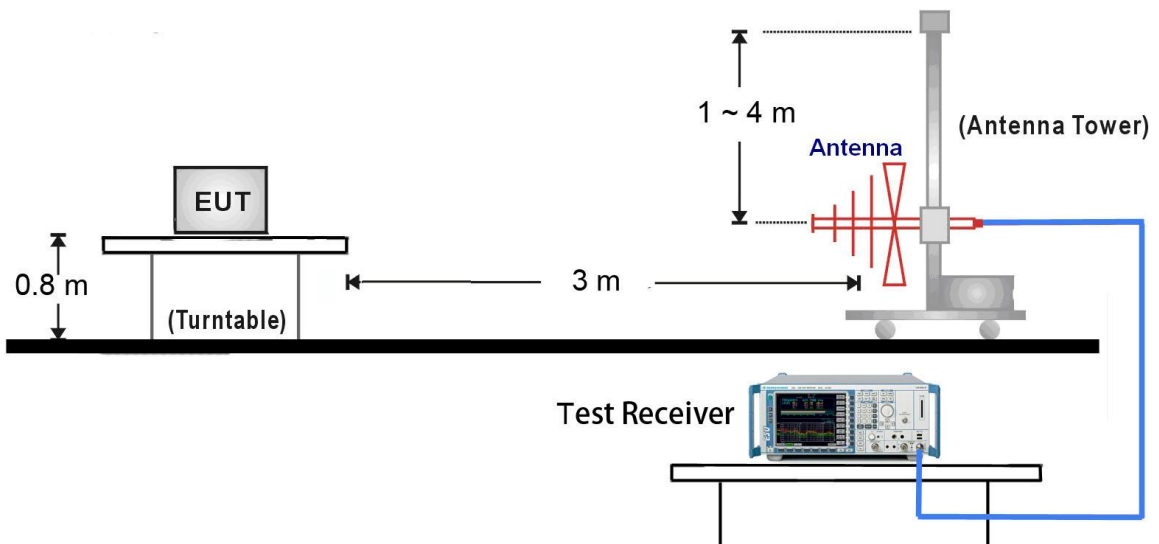

1GHz ~ 18GHz Test Setup:

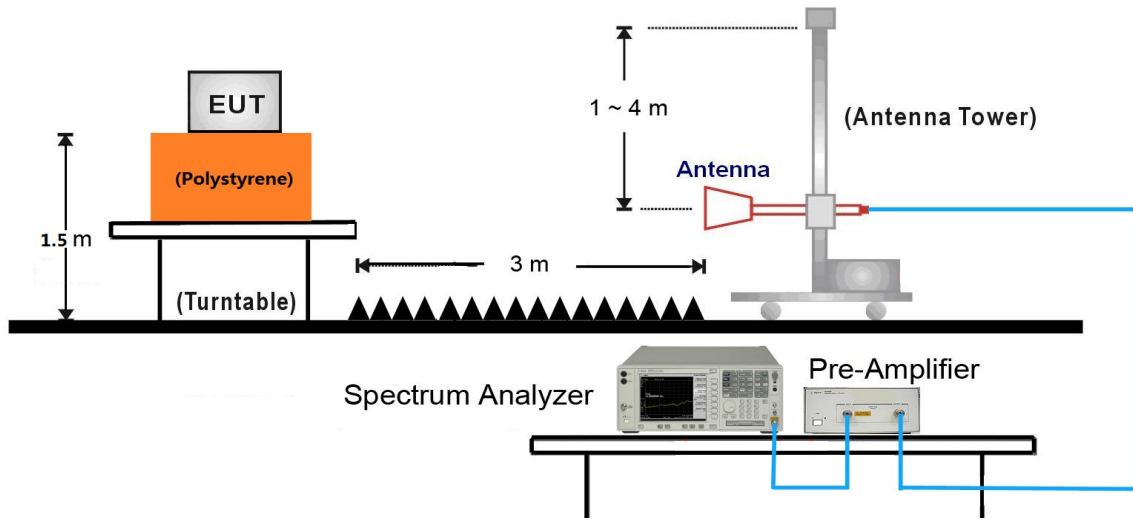

18GHz ~25GHz Test Setup:

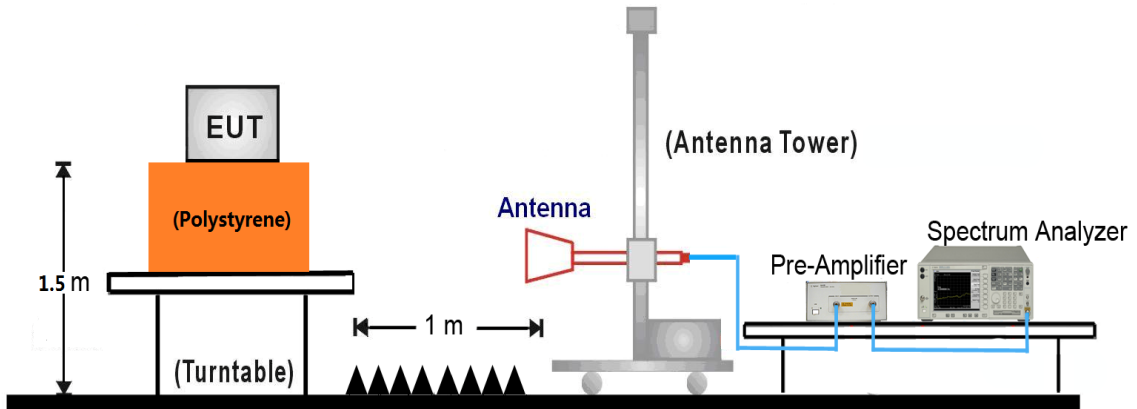

7.6.5. Test Result

Test Mode:	BLE	Test Site:	AC1
Test Channel:	00	Test Engineer:	Kevin Ker
Remark:	1. Average measurement was not performed if peak level lower than average limit. 2. Other frequency was 20dB below limit line within 1-18GHz, there is not show in the report.		

Mark	Frequency (MHz)	Reading Level (dB μ V)	Factor (dB)	Measure Level (dB μ V/m)	Limit (dB μ V/m)	Margin (dB)	Detector	Polarization
	3907.0	35.7	0.2	35.9	74	-38.1	Peak	Horizontal
	4799.5	39.8	2.7	42.5	74	-31.5	Peak	Horizontal
*	7205.0	39.8	7.8	47.6	74	-26.4	Peak	Horizontal
*	8735.0	35.9	8.9	44.8	74	-29.2	Peak	Horizontal
	4799.5	45.0	2.7	47.7	74	-26.3	Peak	Vertical
	4995.0	44.5	3.0	47.5	74	-26.5	Peak	Vertical
*	7205.0	42.6	7.8	50.4	74	-23.6	Peak	Vertical
*	8701.0	36.0	9.0	45.0	74	-29.0	Peak	Vertical

Note 1: "*" is not in restricted band, its limit is 20dBc of the fundamental emission level (88.3dB μ V/m) or 15.209 which is higher.

Note 2: Measure Level (dB μ V/m) = Reading Level (dB μ V) + Factor (dB)

Factor (dB) = Cable Loss (dB) + Antenna Factor (dB/m) - Pre_Amplifier Gain (dB)

Test Mode:	BLE	Test Site:	AC1
Test Channel:	19	Test Engineer:	Kevin Ker
Remark:	1. Average measurement was not performed if peak level lower than average limit. 2. Other frequency was 20dB below limit line within 1-18GHz, there is not show in the report.		

Mark	Frequency (MHz)	Reading Level (dBμV)	Factor (dB)	Measure Level (dBμV/m)	Limit (dBμV/m)	Margin (dB)	Detector	Polarization
	4876.0	39.5	2.7	42.2	74	-31.8	Peak	Horizontal
	7315.5	39.3	8.0	47.3	74	-26.7	Peak	Horizontal
*	8769.0	35.1	8.9	44.0	74	-30.0	Peak	Horizontal
*	10477.5	35.5	12.2	47.7	74	-26.3	Peak	Horizontal
	4876.0	45.3	2.7	48.0	74	-26.0	Peak	Vertical
	7315.5	41.8	8.0	49.8	74	-24.2	Peak	Vertical
*	8692.5	36.1	9.0	45.1	74	-28.9	Peak	Vertical
*	10171.5	35.1	11.7	46.8	74	-27.2	Peak	Vertical

Note 1: "*" is not in restricted band, its limit is 20dBc of the fundamental emission level (86.7dBμV/m) or 15.209 which is higher.

Note 2: Measure Level (dBμV/m) = Reading Level (dBμV) + Factor (dB)

Factor (dB) = Cable Loss (dB) + Antenna Factor (dB/m) - Pre_Amplifier Gain (dB)

Test Mode:	BLE	Test Site:	AC1
Test Channel:	39	Test Engineer:	Kevin Ker
Remark:	1. Average measurement was not performed if peak level lower than average limit. 2. Other frequency was 20dB below limit line within 1-18GHz, there is not show in the report.		

Mark	Frequency (MHz)	Reading Level (dBμV)	Factor (dB)	Measure Level (dBμV/m)	Limit (dBμV/m)	Margin (dB)	Detector	Polarization
	4995.0	38.3	3.0	41.3	74	-32.7	Peak	Horizontal
	7443.0	38.2	8.0	46.2	74	-27.8	Peak	Horizontal
*	8684.0	36.0	9.0	45.0	74	-29.0	Peak	Horizontal
*	10503.0	35.7	12.4	48.1	74	-25.9	Peak	Horizontal
	4961.0	45.3	2.9	48.2	74	-25.8	Peak	Vertical
	7443.0	40.6	8.0	48.6	74	-25.4	Peak	Vertical
*	8837.0	35.4	9.1	44.5	74	-29.5	Peak	Vertical
*	10494.5	34.6	12.4	47.0	74	-27.0	Peak	Vertical

Note 1: "*" is not in restricted band, its limit is 20dBc of the fundamental emission level (84.5dBμV/m) or 15.209 which is higher.

Note 2: Measure Level (dBμV/m) = Reading Level (dBμV) + Factor (dB)

Factor (dB) = Cable Loss (dB) + Antenna Factor (dB/m) - Pre_Amplifier Gain (dB)

The worst case of Radiated Emission below 1GHz:

Site: AC2	Time: 2017/07/12 - 13:27
Limit: FCC_Part15.209_RE(3m)	Engineer: Kevin Ker
Probe: VULB9162_0.03-8GHz	Polarity: Horizontal
EUT: Segway miniLITE	Power: By Battery
Worse Case Mode: Transmit by BLE at channel 2402MHz	



No	Flag	Mark	Frequency (MHz)	Measure Level (dBuV/m)	Reading Level (dBuV)	Over Limit (dB)	Limit (dBuV/m)	Factor (dB)	Type
1			47.500	17.500	2.530	-22.500	40.000	14.970	QP
2			139.860	23.533	14.020	-19.967	43.500	9.513	QP
3		*	167.000	27.674	17.543	-15.826	43.500	10.131	QP
4			266.800	19.385	5.368	-26.615	46.000	14.017	QP
5			383.000	22.083	5.712	-23.917	46.000	16.371	QP
6			771.650	24.592	2.070	-21.408	46.000	22.522	QP

Note 1: Measure Level (dB μ V/m) = Reading Level (dB μ V) + Factor (dB)

Factor (dB) = Cable Loss (dB) + Antenna Factor (dB/m)

Note 2: The test trace is same as the ambient noise and the amplitude of the emissions are attenuated more than 20dB below the permissible (the test frequency range: 9kHz ~ 30MHz, 18GHz ~ 25GHz), therefore no data appear in the report.

Site: AC2	Time: 2017/07/12 - 13:33
Limit: FCC_Part15.209_RE(3m)	Engineer: Kevin Ker
Probe: VULB9162_0.03-8GHz	Polarity: Vertical
EUT: Segway miniLITE	Power: By Battery
Worse Case Mode: Transmit by BLE at channel 2402MHz	

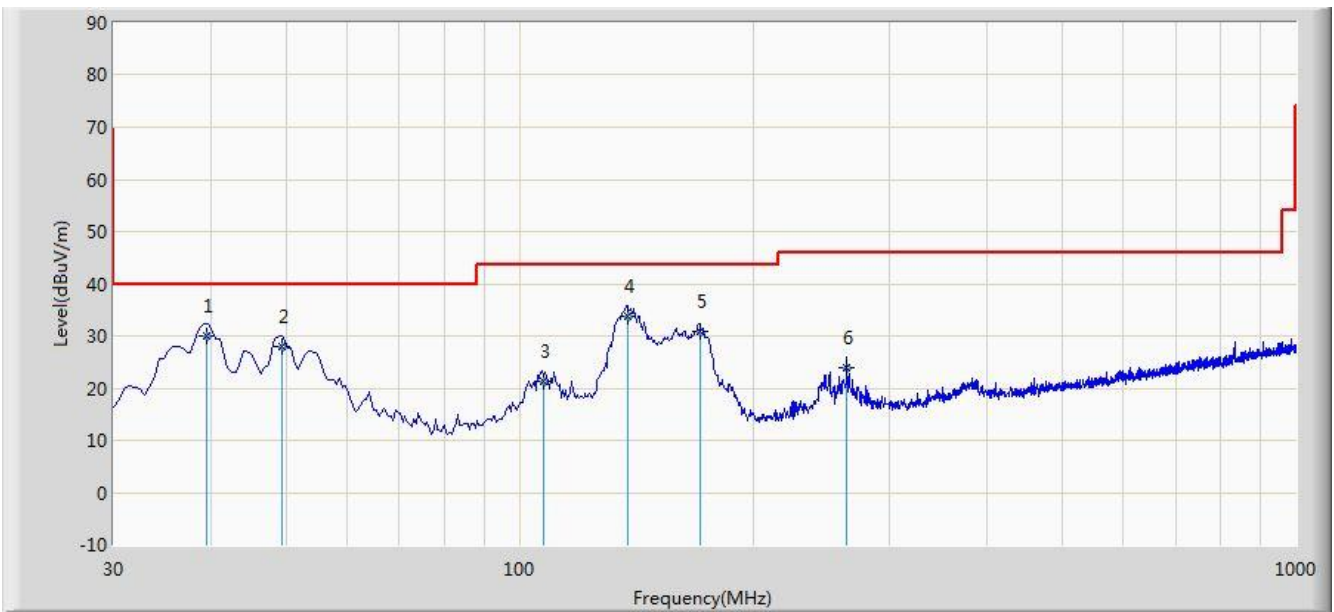

No	Flag	Mark	Frequency (MHz)	Measure Level (dBuV/m)	Reading Level (dBuV)	Over Limit (dB)	Limit (dBuV/m)	Factor (dB)	Type
1			39.500	30.016	16.250	-9.984	40.000	13.767	QP
2			49.500	27.960	13.000	-12.040	40.000	14.960	QP
3			107.500	21.291	8.260	-22.209	43.500	13.031	QP
4		*	138.000	33.627	24.030	-9.873	43.500	9.596	QP
5			171.250	30.735	20.400	-12.765	43.500	10.335	QP
6			263.880	23.988	10.025	-22.012	46.000	13.963	QP

Note 1: Measure Level (dB μ V/m) = Reading Level (dB μ V) + Factor (dB)

Factor (dB) = Cable Loss (dB) + Antenna Factor (dB/m)

Note 2: The test trace is same as the ambient noise and the amplitude of the emissions are attenuated more than 20dB below the permissible (the test frequency range: 9kHz ~ 30MHz, 18GHz ~ 25GHz), therefore no data appear in the report.

7.7. Radiated Restricted Band Edge Measurement

7.7.1. Test Result

Site: AC1	Time: 2017/07/11 - 19:43
Limit: FCC_Part15.209_RE(3m)	Engineer: Kevin Ker
Probe: BBHA9120D_1-18GHz	Polarity: Horizontal
EUT: Segway miniLITE	Power: By Battery
Note: Transmit by BLE at channel 2402MHz	

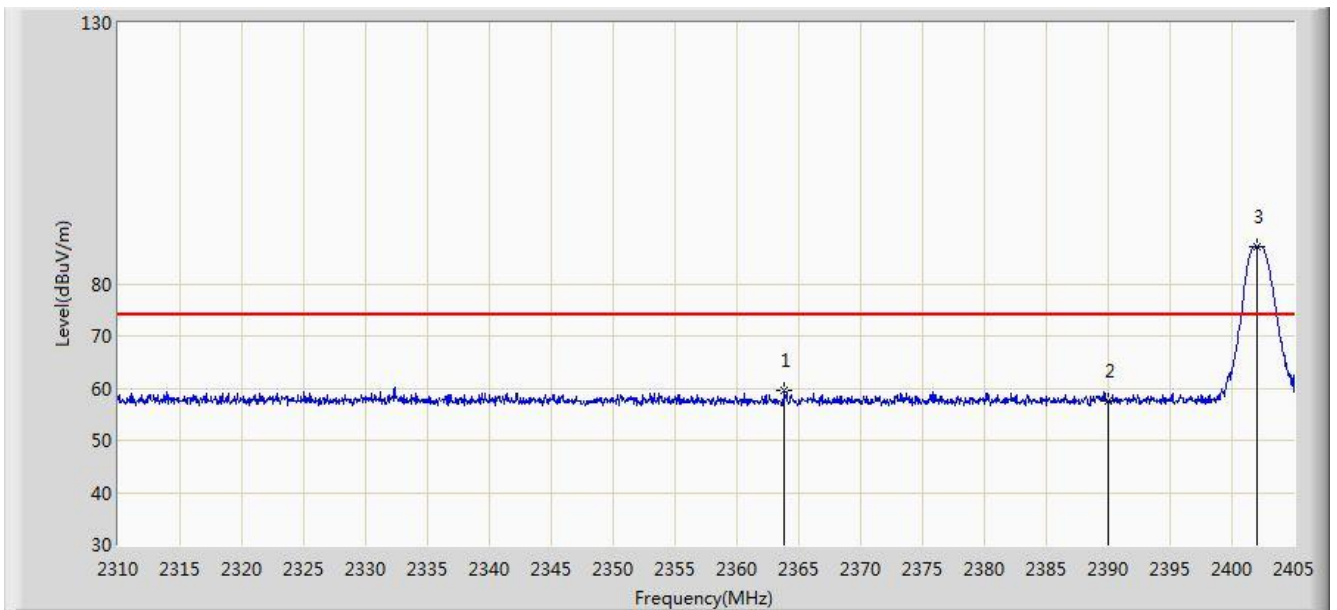

No	Flag	Mark	Frequency (MHz)	Measure Level (dBuV/m)	Reading Level (dBuV)	Over Limit (dB)	Limit (dBuV/m)	Factor (dB)	Type
1			2363.817	59.494	28.242	-14.506	74.000	31.252	PK
2			2390.000	57.527	26.324	-16.473	74.000	31.203	PK
3			2402.008	87.101	55.917	N/A	N/A	31.184	PK

Note: Measure Level (dB μ V/m) = Reading Level (dB μ V) + Factor (dB)

Factor (dB) = Cable Loss (dB) + Antenna Factor (dB/m)

Site: AC1	Time: 2017/07/11 - 20:03
Limit: FCC_Part15.209_RE(3m)	Engineer: Kevin Ker
Probe: BBHA9120D_1-18GHz	Polarity: Horizontal
EUT: Segway miniLITE	Power: By Battery
Note: Transmit by BLE at channel 2402MHz	

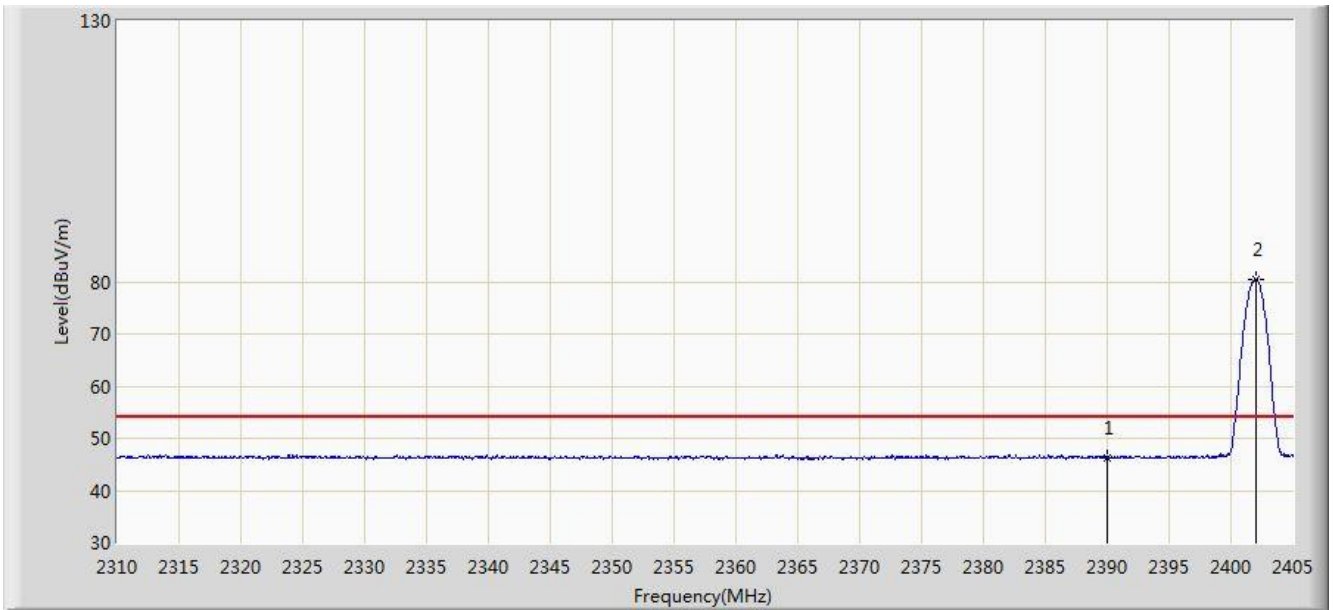

No	Flag	Mark	Frequency (MHz)	Measure Level (dBuV/m)	Reading Level (dBuV)	Over Limit (dB)	Limit (dBuV/m)	Factor (dB)	Type
1			2390.000	46.316	15.113	-7.684	54.000	31.203	AV
2			2402.008	80.504	49.320	N/A	N/A	31.184	AV

Note: Measure Level (dBμV/m) = Reading Level (dBμV) + Factor (dB)

Factor (dB) = Cable Loss (dB) + Antenna Factor (dB/m)

Site: AC1	Time: 2017/07/11 - 20:08
Limit: FCC_Part15.209_RE(3m)	Engineer: Kevin Ker
Probe: BBHA9120D_1-18GHz	Polarity: Vertical
EUT: Segway miniLITE	Power: By Battery
Note: Transmit by BLE at channel 2402MHz	

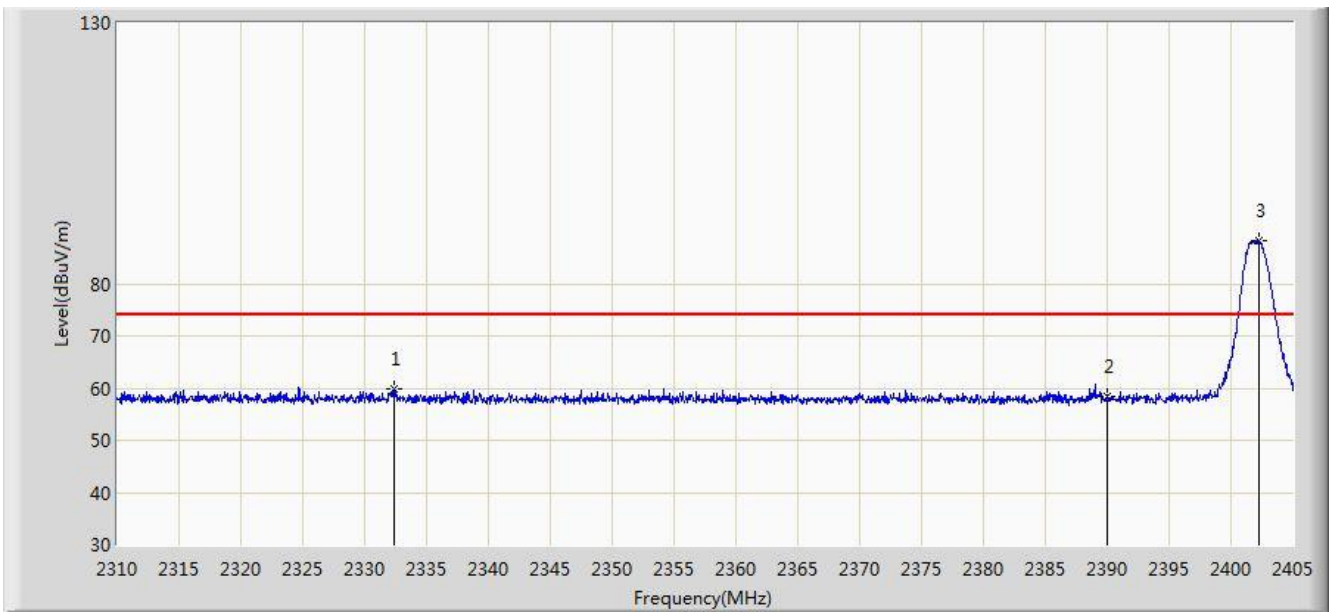

No	Flag	Mark	Frequency (MHz)	Measure Level (dBuV/m)	Reading Level (dBuV)	Over Limit (dB)	Limit (dBuV/m)	Factor (dB)	Type
1			2332.420	59.991	28.626	-14.009	74.000	31.365	PK
2			2390.000	58.327	27.124	-15.673	74.000	31.203	PK
3			2402.245	88.282	57.098	N/A	N/A	31.184	PK

Note: Measure Level (dBμV/m) = Reading Level (dBμV) + Factor (dB)

Factor (dB) = Cable Loss (dB) + Antenna Factor (dB/m)

Site: AC1	Time: 2017/07/11 - 20:09
Limit: FCC_Part15.209_RE(3m)	Engineer: Kevin Ker
Probe: BBHA9120D_1-18GHz	Polarity: Vertical
EUT: Segway miniLITE	Power: By Battery
Note: Transmit by BLE at channel 2402MHz	

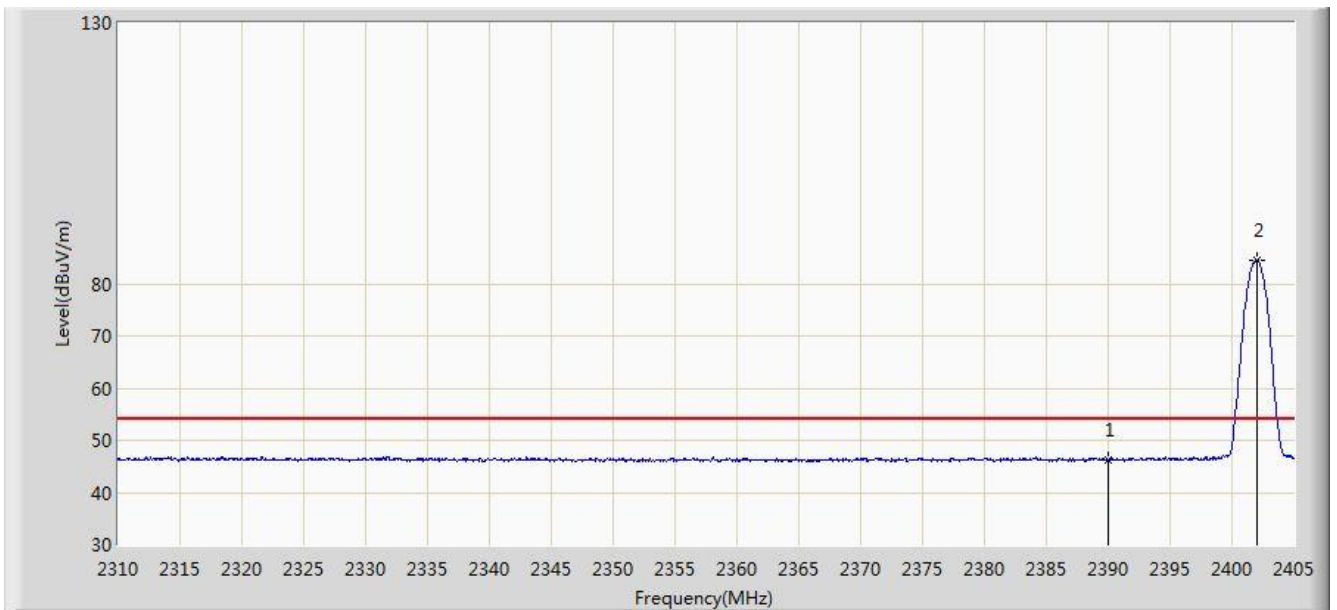

No	Flag	Mark	Frequency (MHz)	Measure Level (dBuV/m)	Reading Level (dBuV)	Over Limit (dB)	Limit (dBuV/m)	Factor (dB)	Type
1			2390.000	46.180	14.977	-7.820	54.000	31.203	AV
2			2402.008	84.571	53.387	N/A	N/A	31.184	AV

Note: Measure Level (dB μ V/m) = Reading Level (dB μ V) + Factor (dB)

Factor (dB) = Cable Loss (dB) + Antenna Factor (dB/m)

Site: AC1	Time: 2017/07/11 - 20:38
Limit: FCC_Part15.209_RE(3m)	Engineer: Kevin Ker
Probe: BBHA9120D_1-18GHz	Polarity: Horizontal
EUT: Segway miniLITE	Power: By Battery
Note: Transmit by BLE at channel 2480MHz	

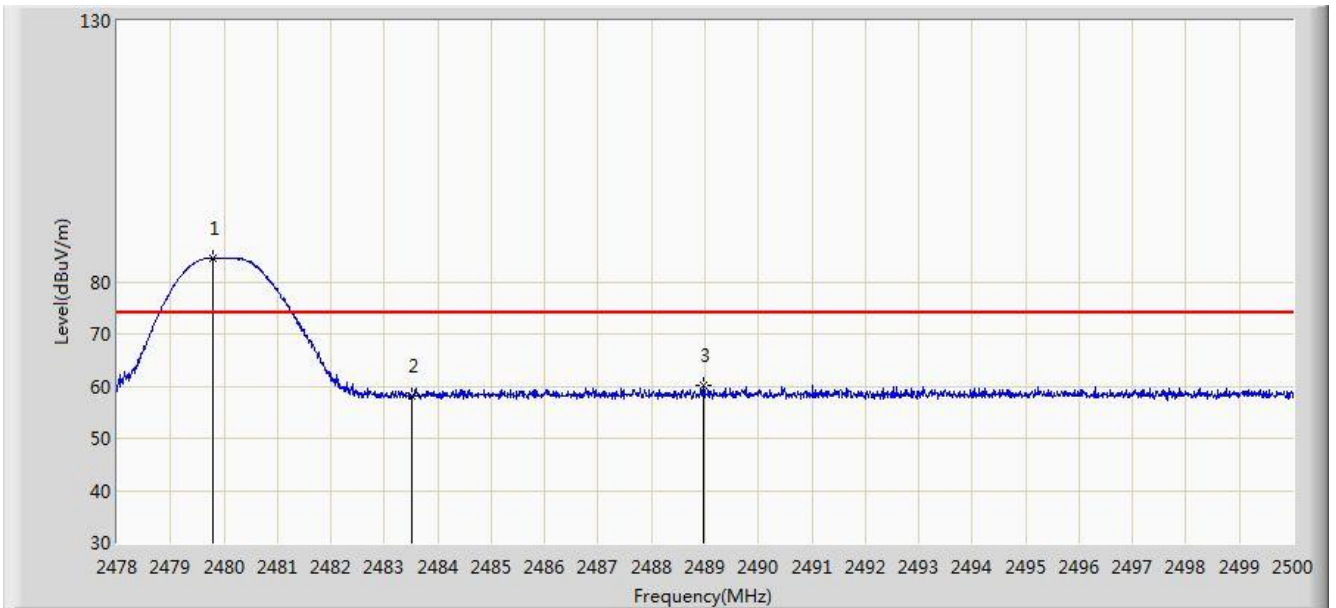

No	Flag	Mark	Frequency (MHz)	Measure Level (dBuV/m)	Reading Level (dBuV)	Over Limit (dB)	Limit (dBuV/m)	Factor (dB)	Type
1			2479.804	84.524	53.340	N/A	N/A	31.184	PK
2			2483.500	58.141	26.948	-15.859	74.000	31.194	PK
3			2488.967	60.283	29.075	-13.717	74.000	31.207	PK

Note: Measure Level (dB μ V/m) = Reading Level (dB μ V) + Factor (dB)

Factor (dB) = Cable Loss (dB) + Antenna Factor (dB/m)

Site: AC1	Time: 2017/07/11 - 20:42
Limit: FCC_Part15.209_RE(3m)	Engineer: Kevin Ker
Probe: BBHA9120D_1-18GHz	Polarity: Horizontal
EUT: Segway miniLITE	Power: By Battery
Note: Transmit by BLE at channel 2480MHz	

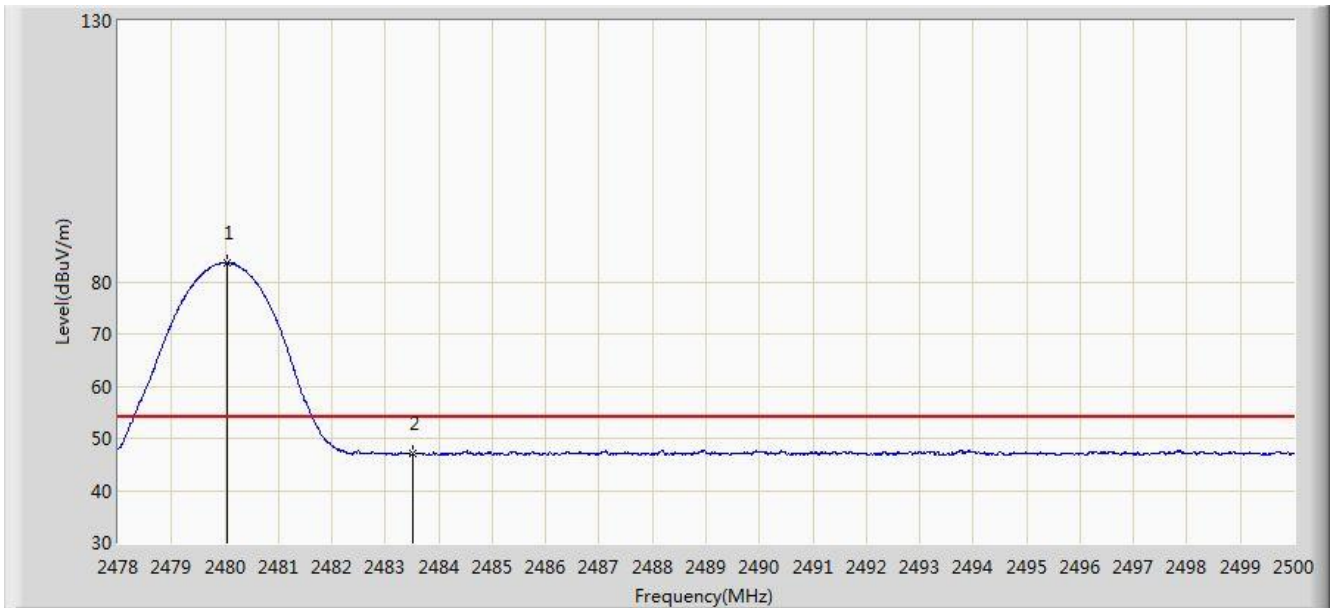

No	Flag	Mark	Frequency (MHz)	Measure Level (dBuV/m)	Reading Level (dBuV)	Over Limit (dB)	Limit (dBuV/m)	Factor (dB)	Type
1			2480.046	83.601	52.417	N/A	N/A	31.184	AV
2			2483.500	46.997	15.804	-7.003	54.000	31.194	AV

Note: Measure Level (dB μ V/m) = Reading Level (dB μ V) + Factor (dB)

Factor (dB) = Cable Loss (dB) + Antenna Factor (dB/m)

Site: AC1	Time: 2017/07/11 - 20:43
Limit: FCC_Part15.209_RE(3m)	Engineer: Kevin Ker
Probe: BBHA9120D_1-18GHz	Polarity: Vertical
EUT: Segway miniLITE	Power: By Battery
Note: Transmit by BLE at channel 2480MHz	

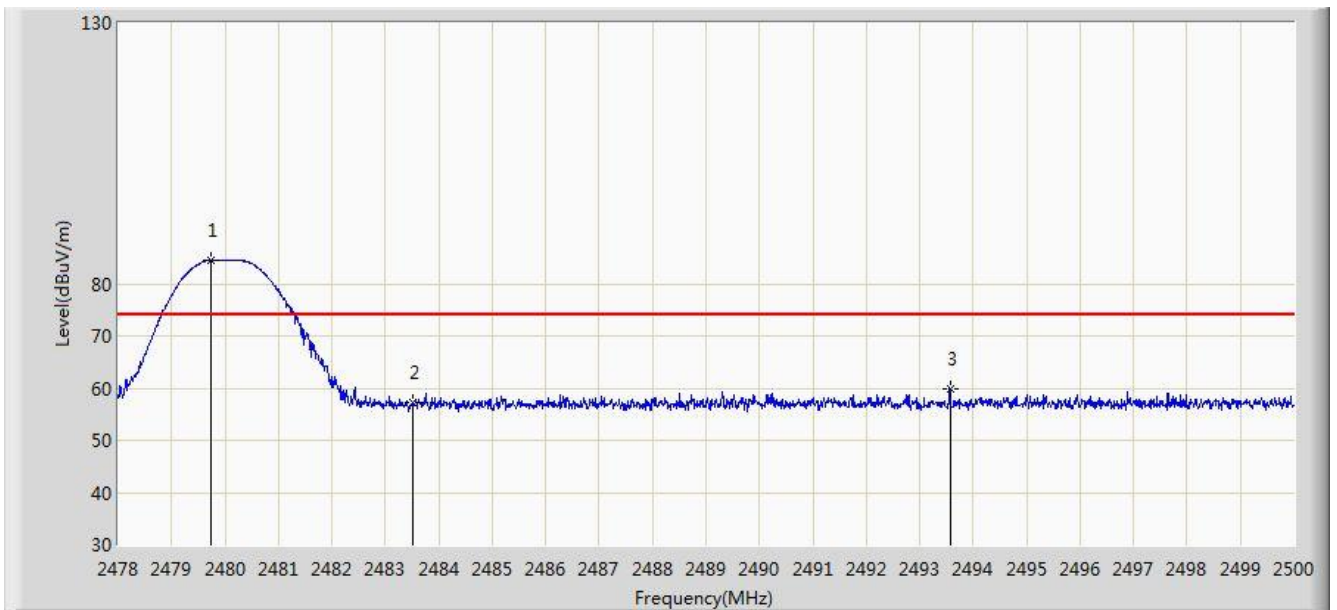

No	Flag	Mark	Frequency (MHz)	Measure Level (dBuV/m)	Reading Level (dBuV)	Over Limit (dB)	Limit (dBuV/m)	Factor (dB)	Type
1			2479.738	84.547	53.364	10.547	74.000	31.184	PK
2			2483.500	57.156	25.963	-16.844	74.000	31.194	PK
3			2493.565	59.984	28.764	-14.016	74.000	31.220	PK

Note: Measure Level (dB μ V/m) = Reading Level (dB μ V) + Factor (dB)

Factor (dB) = Cable Loss (dB) + Antenna Factor (dB/m)

Site: AC1	Time: 2017/07/11 - 20:45
Limit: FCC_Part15.209_RE(3m)	Engineer: Kevin Ker
Probe: BBHA9120D_1-18GHz	Polarity: Vertical
EUT: Segway miniLITE	Power: By Battery
Note: Transmit by BLE at channel 2480MHz	

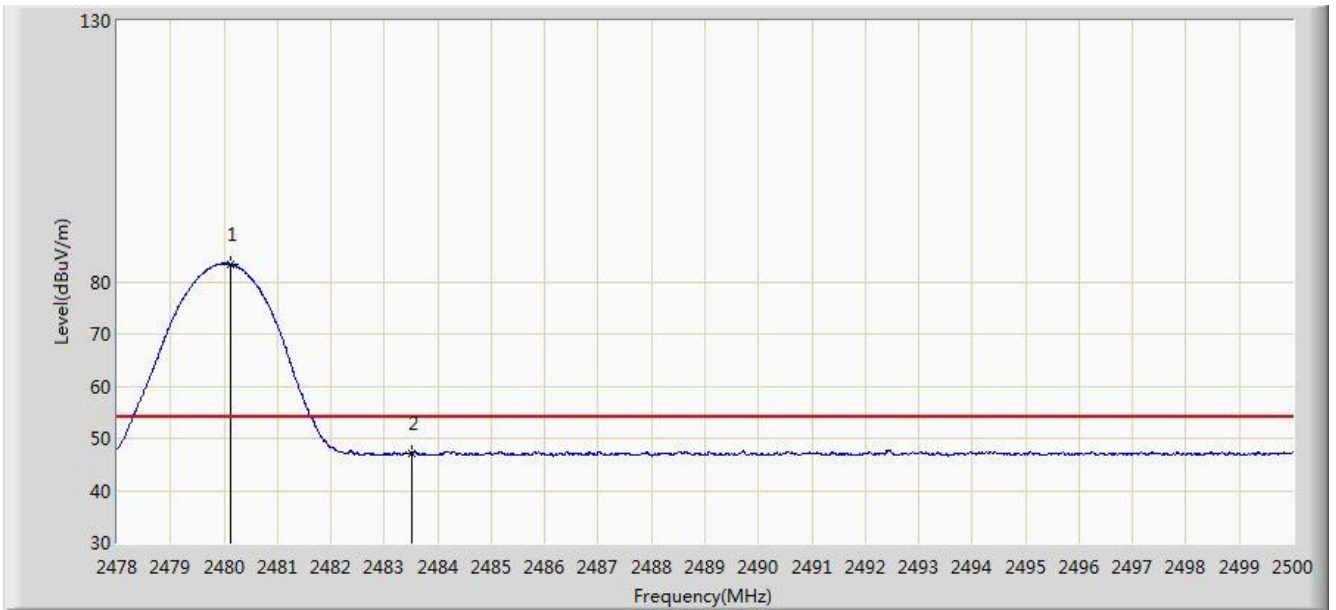

No	Flag	Mark	Frequency (MHz)	Measure Level (dBuV/m)	Reading Level (dBuV)	Over Limit (dB)	Limit (dBuV/m)	Factor (dB)	Type
1			2480.112	83.403	52.219	N/A	N/A	31.184	AV
2			2483.500	47.010	15.817	-6.990	54.000	31.194	AV

Note: Measure Level (dB μ V/m) = Reading Level (dB μ V) + Factor (dB)

Factor (dB) = Cable Loss (dB) + Antenna Factor (dB/m)

7.8. AC Conducted Emissions Measurement

7.8.1. Test Limit

FCC Part 15 Subpart C Paragraph 15.207 Limits		
Frequency (MHz)	QP (dBuV)	AV (dBuV)
0.15 - 0.50	66 - 56	56 - 46
0.50 - 5.0	56	46
5.0 - 30	60	50

Note 1: The lower limit shall apply at the transition frequencies.

Note 2: The limit decreases linearly with the logarithm of the frequency in the range 0.15MHz to 0.5MHz.

7.8.2. Test Setup

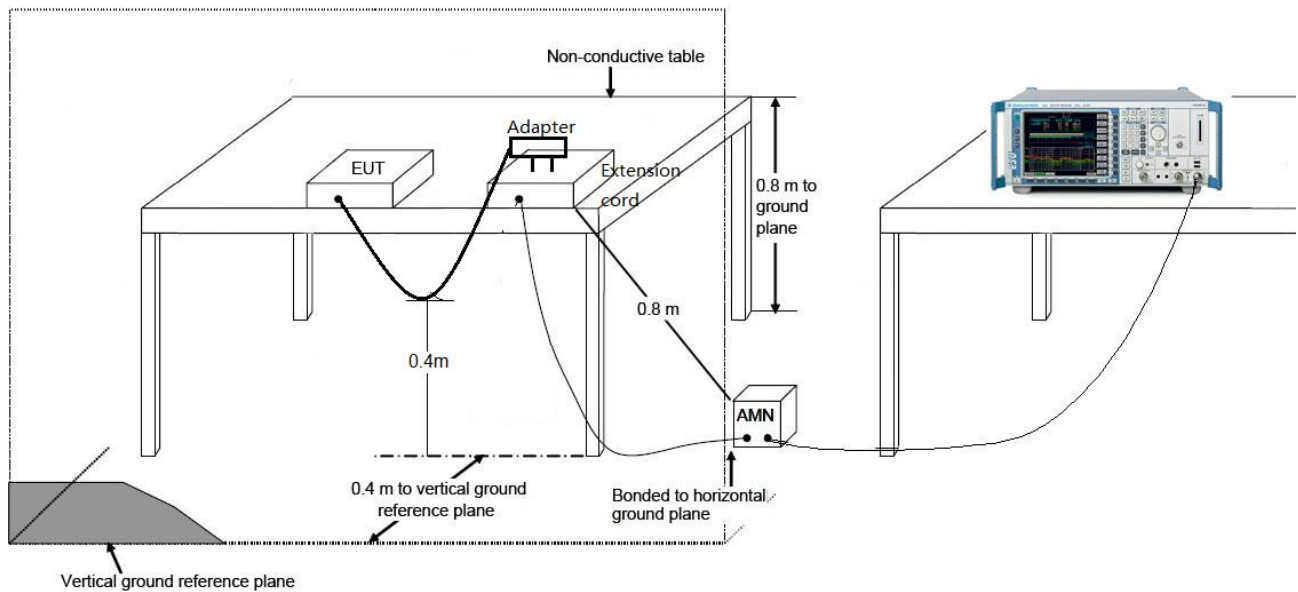

7.8.3. Test Result

Site: SR2	Time: 2017/07/29 - 14:44
Limit: FCC_Part15.207_CE_AC Power	Engineer: Kevin Ker
Probe: ENV216_101683_Filter On	Polarity: Line
EUT: Segway miniLITE	Power: AC 120V/60Hz
Worst Case Mode: Transmit by BLE at channel 2402MHz	

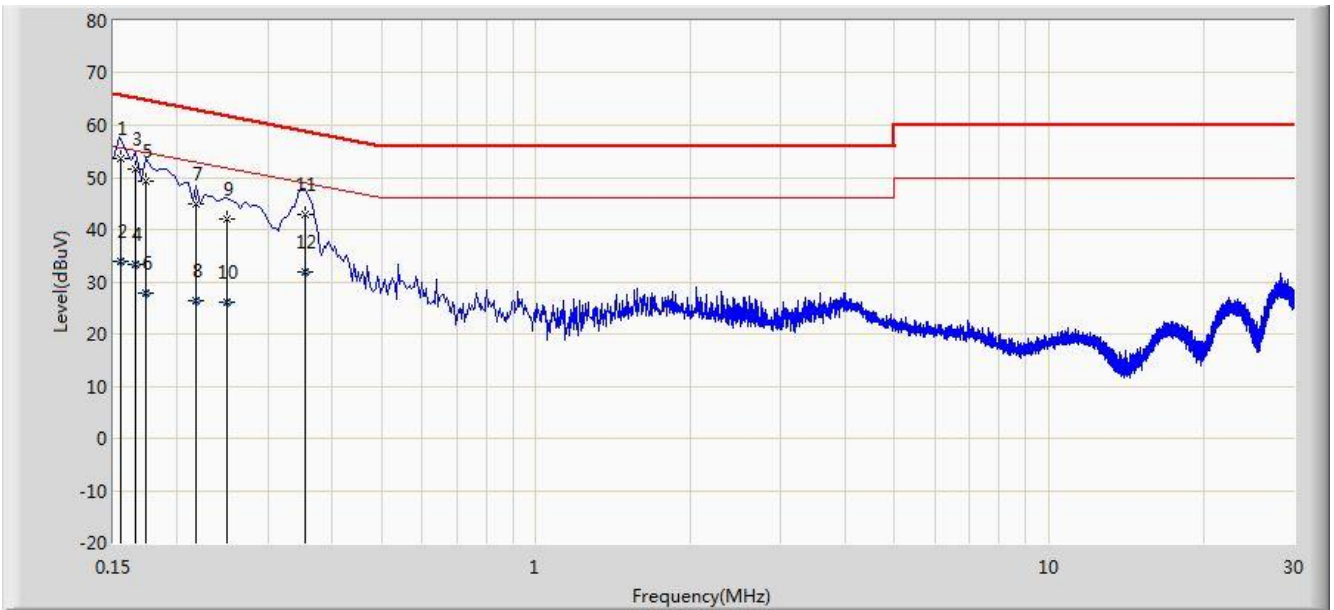

No	Flag	Mark	Frequency (MHz)	Measure Level (dBuV)	Reading Level (dBuV)	Over Limit (dB)	Limit (dBuV)	Factor (dB)	Type
1		*	0.155	53.706	43.073	-12.022	65.728	10.632	QP
2			0.155	33.855	23.222	-21.873	55.728	10.632	AV
3			0.166	51.654	41.567	-13.504	65.158	10.087	QP
4			0.166	33.381	23.294	-21.777	55.158	10.087	AV
5			0.174	49.376	39.309	-15.391	64.767	10.068	QP
6			0.174	27.876	17.808	-26.891	54.767	10.068	AV
7			0.218	44.903	34.958	-17.992	62.895	9.945	QP
8			0.218	26.369	16.424	-26.526	52.895	9.945	AV
9			0.250	41.983	32.019	-19.774	61.757	9.964	QP
10			0.250	26.108	16.144	-25.650	51.757	9.964	AV
11			0.354	42.770	32.722	-16.098	58.868	10.048	QP
12			0.354	31.841	21.793	-17.027	48.868	10.048	AV

Note: Measure Level (dBμV) = Reading Level (dBμV) + Factor (dB)

Factor (dB) = Cable Loss (dB) + LISN Factor (dB)

Site: SR2	Time: 2017/07/29 - 14:55
Limit: FCC_Part15.207_CE_AC Power	Engineer: Kevin Ker
Probe: ENV216_101683_Filter On	Polarity: Neutral
EUT: Segway miniLITE	Power: AC 120V/60Hz
Worst Case Mode: Transmit by BLE at channel 2402MHz	

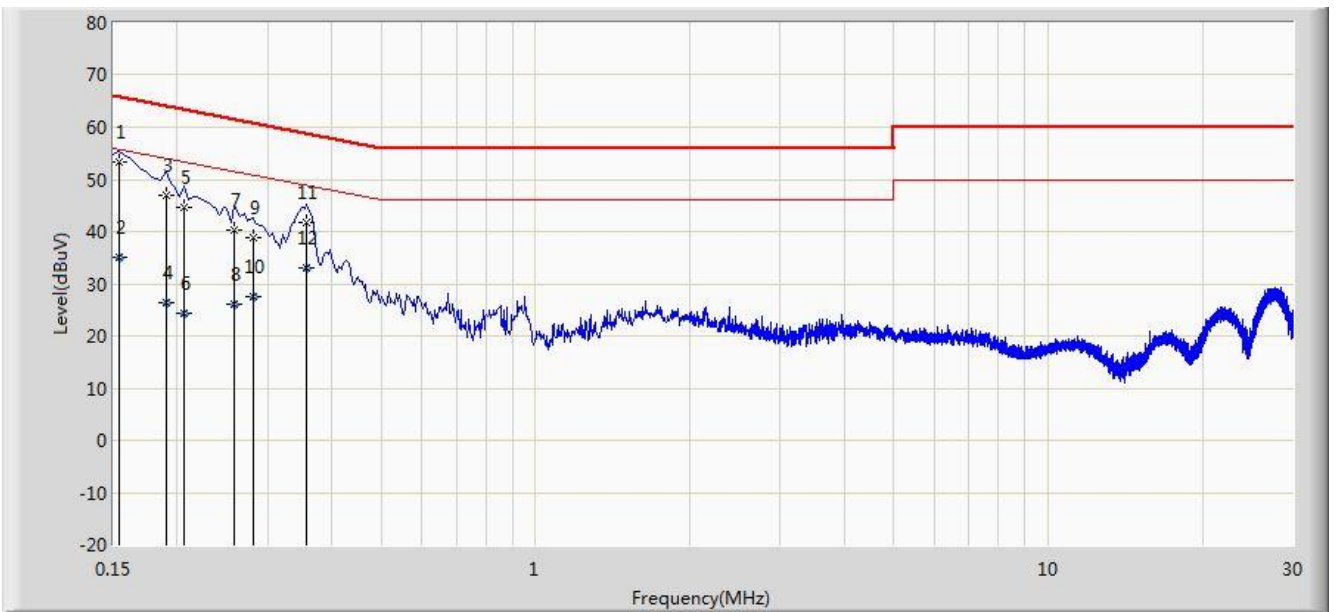

No	Flag	Mark	Frequency (MHz)	Measure Level (dBuV)	Reading Level (dBuV)	Over Limit (dB)	Limit (dBuV)	Factor (dB)	Type
1		*	0.154	53.283	42.567	-12.498	65.781	10.716	QP
2			0.154	34.948	24.232	-20.834	55.781	10.716	AV
3			0.190	47.020	36.992	-17.017	64.037	10.028	QP
4			0.190	26.378	16.350	-27.659	54.037	10.028	AV
5			0.206	44.602	34.601	-18.763	63.365	10.001	QP
6			0.206	24.432	14.431	-28.933	53.365	10.001	AV
7			0.258	40.186	30.179	-21.310	61.496	10.007	QP
8			0.258	26.198	16.191	-25.298	51.496	10.007	AV
9			0.282	38.967	28.942	-21.790	60.757	10.025	QP
10			0.282	27.541	17.517	-23.216	50.757	10.025	AV
11			0.358	41.684	31.603	-17.091	58.775	10.081	QP
12			0.358	33.114	23.033	-15.661	48.775	10.081	AV

Note: Measure Level (dBμV) = Reading Level (dBμV) + Factor (dB)

Factor (dB) = Cable Loss (dB) + LISN Factor (dB)

8. CONCLUSION

The data collected relate only the item(s) tested and show that the **Segway miniLITE** is in compliance with Part 15C of the FCC Rules and IC Rules.

The End