

# 承认书

SPECIFICATION FOR APPROVAL

客户名称 (CUSTOMER) 秉鑫科技

客户料号 (CUSTOMER P/N) :

品名 (DESCRIPTION) : PAYAAAW00B024ZS DATE: 2024/8/28

规格 (SPECIFICATION) : 手表线圈线长25mm 6.5UH Watch coil wire length 25mm 6.5UH

深圳市鸿日昇威科技有限公司

HRSW ELECTRONICS CO.,LTD

ADD: 深圳市龙华新区观澜环观中路48号1栋2楼

2nd Floor, Building 1, No. 48 Huanguan Middle Road, Guanlan, Longhua New  
District, Shenzhen

TEL: +86-15112254520 FAX: +86-0755-28015170

page: 1/2



# SPECIFICATION FOR APPROVAL

## 1. MECHANICAL DIMENSION (UNIT:mm)

## 2. SCHEMATICS:

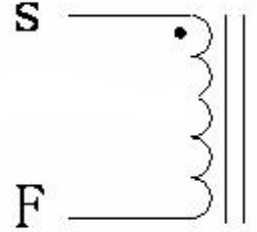
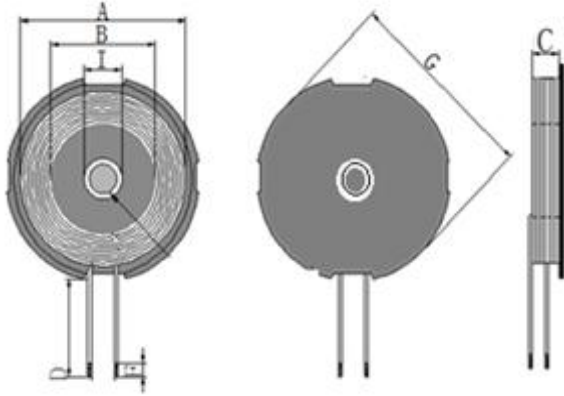

A	B	D	E	G	H	I			
21±1.0	13.5±3	25±2	3±2	26.5MAX	2.6MAX	7.8±0.06			

## 3. WINDING:

STEP	START-FINISH	WIRE TYPE	TURNS	TAPE	REMARK
N1	S-F	∅ 0.08*24mm 2UEW	13TS (Ref)		

## 4. ELECTRICAL SPECIFICATION:

ITEM	L	DCR	L	Temperature	HI-POT
TEST	Coil and diskette	S-F		Normal	
CON	100KHz, 0.25V	AT 25°C			
SPEC	6.5uH±10%	45mΩ Max		0-80°C	

## 5. BILF OF MATERIAL:

NO.	ITEM	MATERIAL SPECIFICATION	MANUFACTURER	SGS NO.
1	Copper wire	0.08*24P	NANJINGJINNINGCO,LTD	
2	Lead-free tin strip	Lead-free tin strip	QIAODO	
3	Magnetic sheet	U52 Hard magnetic	TAIYI CO.,LTD	
4	glue	Gum9999	LIANCHENG CO.,LTD	
5	Magnet	Without	TAIYI CO.,LTD	
6	Gum	Without	CUDAK CO.,LTD	

HRSW ELECTRONICS CO.,LTD		PART NO	
		TITLE	Watch coil wire length 25mm 6.5UH
DRAWN BY	CHECKED BY		APPROVED BY
何伟华 Weihua He	韦立红 Lihong Wei		韦立红 Lihong Wei