

SAR Compliance Test Report

Date of Report	6/10/2017	Client's Contact person:	Samu Salmelin
Number of pages:	44	Responsible Test engineer:	Kirsi Kyllönen
Testing laboratory:	Verkotan Oy Elektriikkatie 17 90590 Oulu Finland	Client:	Kone Corporation Kartanontie 1 00330 Helsinki – Finland Finland
Tested device	KONE Connection 120		
Related reports:			
Testing has been carried out in accordance with:	47CFR §2.1093 Radiofrequency Radiation Exposure Evaluation: Portable Devices FCC published RF exposure KDB procedures RSS-102, Issue 5 Evaluation Procedure for Mobile and Portable Radio Transmitters with Respect to Health Canada's Safety Code 6 for Exposure of Humans to Radio Frequency Fields IEEE 1528 - 2013 IEEE Recommended Practice for Determining the Peak Spatial-Average Specific Absorption Rate (SAR) in the Human Head from Wireless Communications Devices: Measurement Technique		
Documentation:	The test report must always be reproduced in full; reproduction of an excerpt only is subject to written approval of the testing laboratory		
Test Results:	The EUT complies with the requirements in respect of all parameters subject to the test. The test results relate only to devices specified in this document		

Date and signatures: 06.10.2017

Laboratory Manager

TABLE OF CONTENTS

1. SUMMARY OF SAR TEST REPORT	4
1.1 TEST DETAILS	4
1.2 MAXIMUM RESULTS	4
1.2.1 Standalone SAR	4
1.2.2 Simultaneous Transmission SAR.....	5
1.2.3 Maximum Drift	5
1.2.4 Measurement Uncertainty.....	5
2. DESCRIPTION OF THE DEVICE UNDER TEST (DUT)	6
2.1 SUPPORTED FREQUENCY BANDS AND OPERATIONAL MODES	6
2.2 SIMULTANEOUS TRANSMISSION	6
2.3 ANTENNA ALIGNMENT AND SAR TEST EXCLUSIONS	7
3. OUTPUT POWER	8
3.1 MAXIMUM SPECIFIED CONDUCTED OUTPUT POWER.....	8
3.2 TESTED CONDUCTED POWER	8
3.2.1 GSM/GPRS/EGPRS	8
3.2.2 WCDMA	9
3.2.3 Bluetooth.....	9
4. TEST EQUIPMENT	10
4.1 TEST EQUIPMENT LIST	10
4.1.1 Isotropic E-field Probe Type EX3DV4.....	11
CONSTRUCTION	11
4.2 PHANTOMS.....	11
4.3 TISSUE SIMULANTS.....	11
4.3.1 Tissue Simulant Main Ingredients	11
4.4 SYSTEM VALIDATION STATUS.....	12
4.5 SYSTEM CHECK.....	13
4.5.1 Tissue Simulant Verification.....	13
5. TEST PROCEDURE	14
5.1 DEVICE HOLDER	14
5.2 TEST POSITIONS	14
5.2.1 Head Exposure Configuration, 5mm separation distance.....	14
5.3 SCAN PROCEDURES	14
5.4 SAR AVERAGING METHODS.....	15
6. MEASUREMENT UNCERTAINTY	16
7. TEST RESULTS	17
7.1 SAR RESULTS FOR HEAD EXPOSURE CONDITION, 5MM SEPARATION DISTANCE.....	17
7.2 SIMULTANEOUS TRANSMISSION ANALYSIS.....	18
APPENDIX A: PHOTOS OF THE DUT	19

APPENDIX B: SYSTEM CHECK SCAN 20

APPENDIX C: MEASUREMENT SCAN 23

APPENDIX D: RELEVANT PAGES FROM PROBE CALIBRATION REPORTS 28

APPENDIX E: RELEVANT PAGES FROM DIPOLE CALIBRATION REPORTS 31

APPENDIX F FAST SAR RESULTS 37

1. SUMMARY OF SAR TEST REPORT

1.1 Test Details

Equipment under Test (EUT):

Product:	KONE Connection 120
Manufacturer:	Kone
Type:	Elevator Performance Monitor
Serial Number:	KM51237280G01.D00AFI165100002 KM51237280G01.D00AFI165100009
FCC ID Number:	2ALQBKC120
IC ID Number:	4228A-KC120
Hardware Version:	1.3
DUT Number:	23084, 23085
Battery Type used in testing:	The DUT is not battery operated. A power supply cable was used.
Portable/ Mobile device	Mobile
State of the Sample	Pre-production sample

Testing information:

Testing performed:	1-2.3.2017
Notes:	ID707
Document name:	FCC SAR report_KONE Connection 120_05102017.docx
Temperature °C	22±2 / Controlled
Humidity RH%	30±20 / Controlled
Measurement performed by:	Kirsi Kyllönen

1.2 Maximum Results

The maximum reported* SAR values for head configurations are shown in a table below. The device conforms to the requirements of the standards when the maximum reported SAR value is less than or equal to the limit. The SAR limit specified in FCC 47 CFR part 2 (2.1093) for Head SAR_{1g} is 1.6 W/kg.

1.2.1 Standalone SAR

Equipment Class	System	Highest Reported* SAR _{1g} (W/kg) in Head Exposure Condition	Result
PCE	GSM850	0.08	PASS
	PCS1900	0.12	PASS
	WCDMA V	0.13	PASS
	WCDMA II	0.30	PASS
DTS	BLE	0.06	PASS

* Reported SAR Values are scaled to upper limit of power tuning tolerance.

1.2.2 Simultaneous Transmission SAR

Highest Simultaneous Transmission SAR	SAR _{1g} (W/kg) in Head Exposure Condition	Result
PCE + DTS	0.36	PASS

1.2.3 Maximum Drift

Maximum Drift During Measurements	0.15 dB
-----------------------------------	---------

1.2.4 Measurement Uncertainty

Expanded Uncertainty (k=2) 95 %	±22.3 %
---------------------------------	---------

2. DESCRIPTION OF THE DEVICE UNDER TEST (DUT)

The DUT is an elevator performance monitor that is mounted on an elevator car roof. It can be fastened with screws or double sided adhesive tape. In the field use the DUT's cellular module is only powered up for 1/5.26 of time.

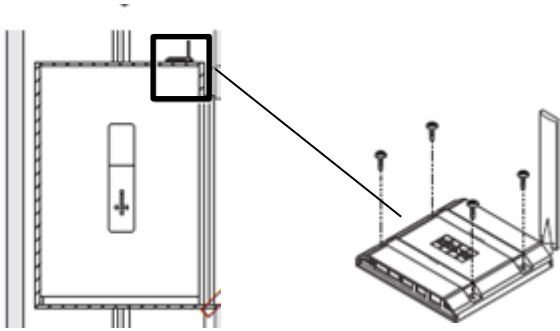

Figure 1 Use case of the DUT on an elevator car roof.

Device Category	Mobile
Exposure Environment	Uncontrolled

2.1 Supported Frequency Bands and Operational Modes

TX Frequency bands	Modes of Operation	Modulation Mode	Transmitter Frequency Range (MHz)
	GSM/GPRS/EDGE 850	GMSK/8PSK	824.2 - 848.8
	GSM/GPRS/EDGE 1900	GMSK/8PSK	1850.2 - 1909.8
	WCDMA/ HSUPA/ HSDPA II	QPSK	1852.4 - 1907.6
	WCDMA/ HSUPA/HSDPA V	QPSK	826.4 - 846.6
	Bluetooth Low Energy	-	2402 - 2480

Bands Operating Outside USA are GSM 900, GSM1800, WCDMA I, WCDMA VI and WCDMA VIII and they not part of this filing.

2.2 Simultaneous transmission

The DUT is utilizing 2 different antennas for tested frequencies. Cellular technologies are utilizing an external antenna and Bluetooth an internal one.

Possible Simultaneous TX combinations
Cellular + BLE

2.3 Antenna alignment and SAR test Exclusions

The external antenna of the DUT has a rotary joint. Impact of antenna position in low and high frequency band was studied and the position causing largest SAR was selected for testing. Four different antenna positions were used;

Antenna Position	Vertical	Horizontal straight	Horizontal right	Horizontal left
WCDMA 850 Fast SAR1g (W/kg)	0.150	0.274	0.297	0.274
WCDMA 1900 Fast SAR1g (W/kg)	0.429	0.502	0.774	0.677

Plots of the study are presented in Appendix F.

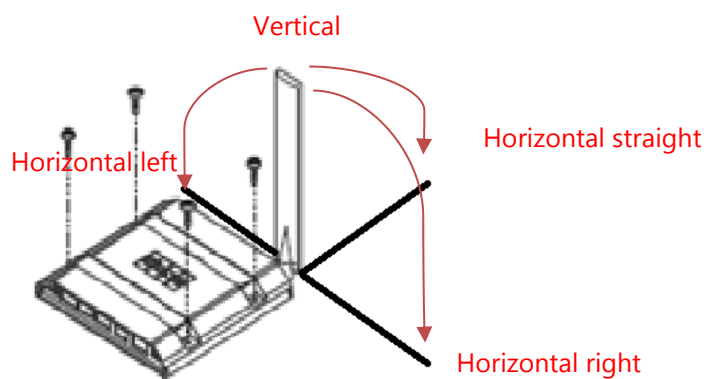

Figure 2 Antenna test positions

3. OUTPUT POWER

3.1 Maximum specified conducted output power

By the manufacturer;

GPRS (GMSK, 4Tx-slot)		
GSM	850	27
PCS	1900	24.2

WCDMA/HSDPA/HSUPA (dBm)		
WCDMA	V	25
WCDMA	II	25

BLE (dBm)	
10	

3.2 Tested conducted power

3.2.1 GSM/GPRS/EGPRS

Slot Configuration	GSM 850 CH 128 824.2 MHz	GSM 850 CH 189 836.6 MHz	GSM 850 CH 251 848.8 MHz	GSM 1900 CH 512 1850.2 MHz	GSM 1900 CH 661 1880.0 MHz	GSM 1900 CH 810 1909.8 MHz
GPRS (GMSK, 1Tx-slot)	30.94	30.87	30.73	27.63	27.8	27.94
GPRS (GMSK, 2Tx-slot)	28.03	27.97	27.82	24.68	24.85	24.99
GPRS (GMSK, 3Tx-slot)	26.24	26.17	26.02	22.9	23.07	23.23
GPRS (GMSK, 4Tx-slot)	25.1	25.02	24.89	21.71	21.89	22.06
EDGE (8PSK, 1Tx-slot)	25.11	25.07	24.82	23.47	23.75	23.88
EDGE (8PSK, 2Tx-slot)	22.16	22.13	22.0	20.57	20.77	20.93
EDGE (8PSK, 3Tx-slot)	20.4	20.32	20.19	18.78	18.96	19.18
EDGE (8PSK, 4Tx-slot)	19.19	19.13	19.02	17.6	17.74	17.94

Time averaged power:

Slot Configuration	GSM850 CH 128 824.2 MHz	GSM 850 CH 190 836.6 MHz	GSM 850 CH 251 848.8MHz	GSM 1900 CH 512 1850.2 MHz	GSM 1900 CH 661 1880.0 MHz	GSM 1900 CH 810 1909.8 MHz
GPRS 1-slot	21.91	21.84	21.70	18.60	18.77	18.91
GPRS 2-slot	22.01	21.95	21.80	18.66	18.83	18.97
GPRS 3-slot	21.98	21.91	21.76	18.64	18.81	18.97
GPRS 4-slot	22.09	22.01	21.88	18.70	18.88	19.05
EDGE 1-slot	16.08	16.04	15.79	14.44	14.72	14.85
EDGE 2-slot	16.14	16.11	15.98	14.55	14.75	14.91
EDGE 3-slot	16.14	16.06	15.93	14.52	14.70	14.92
EDGE 4-slot	16.18	16.12	16.01	14.59	14.73	14.93

The number of Tx slots in GPRS tests was 4 at GSM850 MHz and PCS1900 MHz band. Selection was based on conducted power result comparison with all available uplink slot configurations.

3.2.2 WCDMA

Conducted power measurements for WCDMA modes have been carried out in accordance with 3GPP TS34.1083 and 3GPP TS 34.121-1.

Mode	WCDMA V			WCDMA II		
	CH 4132 826.4 MHz	CH 4182 836.4 MHz	CH 4233 846.6 MHz	CH 9262 1852.4 MHz	CH 9400 1880.0 MHz	CH 9538 1907.6 MHz
RMC 12.2K	23.01	22.4	22.47	21.7	21.4	21.59
HSDPA Subtest-1	22.98	22.36	22.43	21.7	21.38	21.61
HSDPA Subtest-2	22.25	21.64	21.69	21.12	20.78	20.95
HSDPA Subtest-3	22.01	21.4	21.45	20.81	20.54	20.77
HSDPA Subtest-4	21.77	21.15	21.21	20.56	20.27	20.51
HSUPA Subtest-1	22.5	21.9	21.92	21.31	20.98	21.16
HSUPA Subtest-2	22.96	22.36	22.43	21.72	21.31	21.55
HSUPA Subtest-3	21.96	21.35	21.43	20.79	20.46	20.7
HSUPA Subtest-4	22.67	22.37	22.43	21.37	21.24	21.45
HSUPA Subtest-5	22.21	21.6	21.67	21.13	20.71	20.87

SAR tests for HSDPA mode have not been performed as no HSDPA Sub-test mode has an average power > 0.25 dB above the basic WCDMA 12.2 kbps RMC mode.

SAR tests for HSUPA mode have not been performed as no HSUPA Sub-test mode has an average power > 0.25 dB above the basic WCDMA 12.2 kbps RMC mode.

3.2.3 Bluetooth

	Bluetooth		
	CH 0 2402 MHz	CH 39 2441 MHz	CH 78 2480 MHz
Conducted Power	9.0	8.5	8.0

4. TEST EQUIPMENT

Dasy52 near field scanning system, manufactured by SPEAG was used for SAR testing. The test system consists of high precision robotics system (Staubli), robot controller, computer, near-field probe, probe alignment sensor, and a phantom containing the tissue equivalent material. The robot is a six-axis industrial robot performing precise movements to position the probe to the location of maximum electromagnetic field.

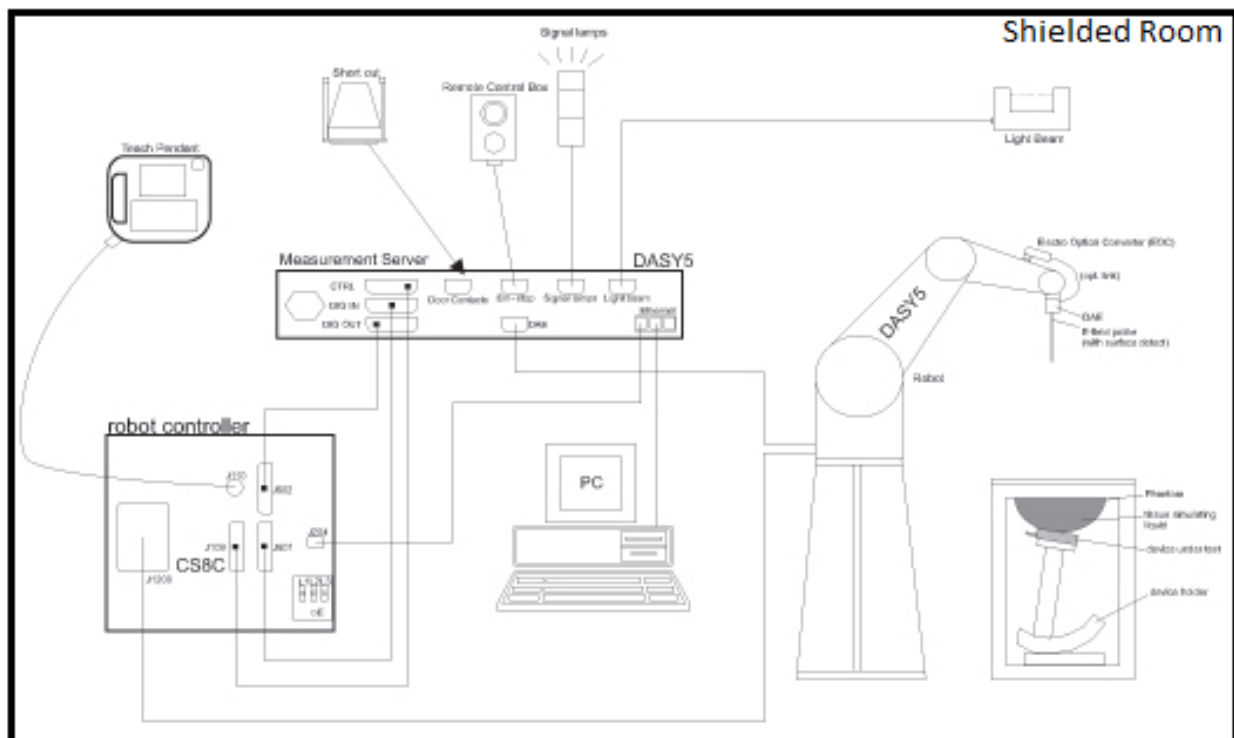

Figure 3 Schematic Laboratory Picture

4.1 Test Equipment List

Main used test system components are listed below. For full equipment list and calibration intervals, please contact the testing laboratory.

Test Equipment	Model	Serial Number	Calibration Date
DAE	DAE4	1332	03.2016
Probe	EX3DV4	3892	03.2016
Dipole	D835V2	448	01.2016
Dipole	D1900V2	511	01.2016
Dipole	D2450V2	758	01.2016
DASY5 Software	52.8.8.1258	-	NA
Signal Generator	SMIQ06B	8349681023	NA
Amplifier	AR	27573	NA
Power Sensor	NRP-Z11	100265	01.2016

4.1.1 Isotropic E-field Probe Type EX3DV4

Construction	Symmetrical design with triangular core Built-in shielding against static charges PEEK enclosure material (resistant to organic solvents, e.g., DGBE)
Calibration	Calibration certificate in Appendix D
Frequency	10 MHz to > 6 GHz (dosimetry); Linearity: ± 0.2 dB (30 MHz to 6 GHz)
Directivity	± 0.3 dB in HSL (rotation around probe axis) ± 0.5 dB in tissue material (rotation normal to probe axis)
Dynamic Range	10 μ W/g to > 100 mW/g, Linearity: ± 0.2 dB
Dimensions	Overall length: 330 mm Tip length: 10 mm Body diameter: 12 mm
Application	General dosimetry up to 6 GHz Compliance tests of mobile phones Fast automatic scanning in arbitrary phantoms

4.2 Phantoms

Elliptical ELI phantom is used for compliance testing of handheld and body-mounted wireless devices in the frequency range of 30 MHz to 6 GHz. Eli phantom is manufactured by SPEAG. The dimensions of the phantom are: Major axis: 600 mm, Minor axis: 400 mm, Shell Thickness 2.0 ± 0.2 mm (bottom plate)
The phantom conforms to the requirements of IEEE 1528 and FCC published RF Exposure KDB Procedures.

4.3 Tissue Simulants

Recommended values for the dielectric parameters of the tissue simulants are given in IEEE 1528 and FCC published RF Exposure KDB Procedures. The dielectric parameters of the used tissue simulants were within $\pm 5\%$ of the recommended values in all frequencies used. SAR testing was carried out within 24 hours of measuring the dielectric parameters. Depth of the tissue simulant was at least 15.0 cm from the inner surface of the flat phantom.

4.3.1 Tissue Simulant Main Ingredients

Simulant liquid used in measurements is manufactured by SPEAG. The main Ingredients are according the manufacturer: Ethanediol, Sodium petroleum sulfonate, 2-Methyl-pentane-2,4-diol, Alkoxyated alcohol, > C16 and water. Exact composition is business secret of SPEAG.

4.4 System Validation Status

Frequency [MHz]	Dipole Type / SN	Probe Type / SN	Calibrated Signal Type	DAE Unit / SN	Validation Done	
					Head tissue simulant	Body tissue simulant
835	D835V2 / 448	EX3DV4 / 3892	CW	DAE4 / 1332	12/2016	12/2016
1900	D1900V2 / 511	EX3DV4 / 3892	CW	DAE4 / 1332	12/2016	12/2016

4.5 System Check

Date	Tissue Type	Tissue Temp. [°C]	Frequency [MHz]	Input Power	Measured SAR _{1g} [W/kg]	1 W Target SAR _{1g} [W/kg]	1 W Normalized SAR _{1g} [W/kg]	Deviation (%)	Plot #
2.3.2017	HBBL600-6000V6	21.3	835	250mW	2.3	9.27	9.2	-0.8	1
2.3.2017	HBBL600-6000V6	21.3	1900	250mW	9.29	38.9	37.16	-4.5	2
1.3.2017	HBBL600-6000V6	21.5	2450	250mW	12.3	51.4	49.2	-4.3	3

4.5.1 Tissue Simulant Verification

Date	Tissue Type	Tissue Temp. [°C]	Frequency [MHz]	Target		Measured		Deviation	
				Dielectric Constant [ε]	Conductivity σ [S/m]	Dielectric Constant [ε]	Conductivity σ [S/m]	ε (%)	σ (%)
2.3.2017	HBBL600-6000V6	22	835	41.5	0.90	42.2	0.94	1.7	4.4
2.3.2017	HBBL600-6000V6	22	837	41.5	0.90	42.2	0.94	1.7	4.4
2.3.2017	HBBL600-6000V6	22	1900	40.0	1.40	40.1	1.47	0.3	5.0
2.3.2017	HBBL600-6000V6	22	1852,5	40.0	1.40	40.2	1.44	0.4	2.9
2.3.2017	HBBL600-6000V6	22	1880	40.0	1.40	40.2	1.45	0.4	3.9
2.3.2017	HBBL600-6000V6	22	1907,6	40.0	1.40	40.1	1.47	0.3	5.0
1.3.2017	HBBL600-6000V6	22	2441	39.2	1.79	40.1	1.85	2.3	3.3
1.3.2017	HBBL600-6000V6	22	2450	39.2	1.80	40.1	1.86	2.3	3.2

5. TEST PROCEDURE

The DUT was set to transmit in a maximum power using a communication tester for the cellular technologies. Bluetooth transmission was activated with test sw.

5.1 Device Holder

The device was placed in the device holder (illustrated below) that is supplied by SPEAG as an integral part of the Dasysystem.



Device holder supplied by SPEAG

5.2 Test Positions

5.2.1 Head Exposure Configuration, 5mm separation distance

The device was placed in the SPEAG holder upside down and placed below the flat phantom. The distance between the device and the phantom was kept at 5mm using a separate flat spacer that was removed before the start of the measurements. Device has a movable external antenna and fast SAR was run to select the antenna position giving highest SAR values. Tests were run on selected horizontal right antenna position.

Pictures of the test positions are presented in appendix A and fast SAR results for antenna position selection are presented in appendix F.

5.3 Scan Procedures

First, area scans were used for determination of the field distribution. Next, a zoom scan, a minimum of 5x5x7 points covering a volume of at least 30x30x30mm, was performed around the highest E-field value to determine the averaged SAR value. Drift was determined by measuring the same point at the start of the area scan and again at the end of the zoom scan. Fast SAR is measured according to the KDB 447498 D01 General RF Exposure Guidance v05r01.

5.4 SAR Averaging Methods

The maximum SAR value was averaged over a cube of tissue using interpolation and extrapolation.

The interpolation, extrapolation and maximum search routines within Dasy52 are all based on the modified Quadratic Shepard's method (Robert J. Renka, "Multivariate Interpolation of Large Sets of Scattered Data", University of North Texas ACM Transactions on Mathematical Software, vol. 14, no. 2, June 1988, pp. 139-148).

The interpolation scheme combines a least-square fitted function method with a weighted average method. A trivariate 3-D / bivariate 2-D quadratic function is computed for each measurement point and fitted to neighbouring points by a least-square method. For the zoom scan, inverse distance weighting is incorporated to fit distant points more accurately. The interpolating function is finally calculated as a weighted average of the quadratics.

In the zoom scan, the interpolation function is used to extrapolate the Peak SAR from the deepest measurement points to the inner surface of the phantom.

6. MEASUREMENT UNCERTAINTY

DASY5 Uncertainty Budget According to IEEE 1528-2013 and IEC 62209-1/201x (0.3 - 3 GHz range)								
Error Description	Uncert. value	Prob. Dist.	Div.	(c_i) 1g	(c_i) 10g	Std. Unc. (1g)	Std. Unc. (10g)	(v_i) V_{eff}
Measurement System								
Probe Calibration	±6.0 %	N	1	1	1	±6.0 %	±6.0 %	∞
Axial Isotropy	±4.7 %	R	√ ₂	0.7	0.7	±1.9 %	±1.9 %	∞
Hemispherical Isotropy	±9.6 %	R	√ ₂	0.7	0.7	±3.9 %	±3.9 %	∞
Boundary Effects	±1.0 %	R	√ ₂	1	1	±0.6 %	±0.6 %	∞
Linearity	±4.7 %	R	√ ₂	1	1	±2.7 %	±2.7 %	∞
System Detection Limits	±1.0 %	R	√ ₂	1	1	±0.6 %	±0.6 %	∞
Modulation Response ^m	±2.4 %	R	√ ₂	1	1	±1.4 %	±1.4 %	∞
Readout Electronics	±0.3 %	N	1	1	1	±0.3 %	±0.3 %	∞
Response Time	±0.8 %	R	√ ₂	1	1	±0.5 %	±0.5 %	∞
Integration Time	±2.6 %	R	√ ₂	1	1	±1.5 %	±1.5 %	∞
RF Ambient Noise	±3.0 %	R	√ ₂	1	1	±1.7 %	±1.7 %	∞
RF Ambient Reflections	±3.0 %	R	√ ₂	1	1	±1.7 %	±1.7 %	∞
Probe Positioner	±0.4 %	R	√ ₂	1	1	±0.2 %	±0.2 %	∞
Probe Positioning	±2.9 %	R	√ ₂	1	1	±1.7 %	±1.7 %	∞
Max. SAR Eval.	±2.0 %	R	√ ₂	1	1	±1.2 %	±1.2 %	∞
Test Sample Related								
Device Positioning	±2.9 %	N	1	1	1	±2.9 %	±2.9 %	145
Device Holder	±3.6 %	N	1	1	1	±3.6 %	±3.6 %	5
Power Drift	±5.0 %	R	√ ₂	1	1	±2.9 %	±2.9 %	∞
Power Scaling ^p	±0 %	R	√ ₂	1	1	±0.0 %	±0.0 %	∞
Phantom and Setup								
Phantom Uncertainty	±6.1 %	R	√ ₂	1	1	±3.5 %	±3.5 %	∞
SAR correction	±1.9 %	R	√ ₂	1	0.84	±1.1 %	±0.9 %	∞
Liquid Conductivity (mea.) ^{DAK}	±2.5 %	R	√ ₂	0.78	0.71	±1.1 %	±1.0 %	∞
Liquid Permittivity (mea.) ^{DAK}	±2.5 %	R	√ ₂	0.26	0.26	±0.3 %	±0.4 %	∞
Temp. unc. - Conductivity ^{BB}	±3.4 %	R	√ ₂	0.78	0.71	±1.5 %	±1.4 %	∞
Temp. unc. - Permittivity ^{BB}	±0.4 %	R	√ ₂	0.23	0.26	±0.1 %	±0.1 %	∞
Combined Std. Uncertainty						±11.2 %	±11.1 %	361
Expanded STD Uncertainty						±22.3 %	±22.2 %	

7. TEST RESULTS

7.1 SAR Results for Head Exposure Condition, 5mm separation distance

Band	Channel	TX Slot configuration	Maximum Power [dBm]	Conducted Power [dBm]	Power Drift [dB]	Antenna Position	GPRS Dudy Cycle	Measured SAR _{1g} [mW/g]	Scaling Factor	Field Dudy Cycle	Reported SAR _{1g} [mW/g]	Plot #
GSM850	190	4-slots	27	25.02	0.02	Horizontal right	1:2.12	0.256	1.58	1:5.26	0.08	4
GSM1900	661	4-slots	24.2	21.89	-0.06	Horizontal right	1:2.12	0.372	1.70	1:5.26	0.12	5

Band	Channel	Mode	Maximum Power [dBm]	Conducted Power [dBm]	Power Drift [dB]	Antenna Position	Dudy Cycle	Measured SAR _{1g} [mW/g]	Scaling Factor	Field Dudy Cycle	Reported SAR _{1g} [mW/g]	Plot #
V	4183	RMC 12.2K	25	21.4	-0.07	Horizontal right	1:1	0.295	2.29	1:5.26	0.13	6
II	9262	RMC 12.2K	25	23.01	0.04	Horizontal right	1:1	0.999	1.58	1:5.26	0.30	7
II	9400	RMC 12.2K	25	22.4	0.03	Horizontal right	1:1	0.911	1.82	1:5.26	0.32	-
II	9538	RMC 12.2K	25	22.47	-0.03	Horizontal right	1:1	0.938	1.79	1:5.26	0.32	-

Repeated measurement:

Band	Channel	Mode	Maximum Power [dBm]	Conducted Power [dBm]	Power Drift [dB]	Antenna Position	Dudy Cycle	Measured SAR _{1g} [mW/g]	Scaling Factor	Field Dudy Cycle	Reported SAR _{1g} [mW/g]	Plot #
II	9262	RMC 12.2K	25	23.01	0,02	Horizontal right	1:1	0.782	1.58	1:5.26	0.24	-

Band	Channel	Maximum Power [dBm]	Conducted Power [dBm]	Power Drift [dB]	Antenna Position	Dudy Cycle	Measured SAR _{1g} [mW/g]	Scaling Factor	Reported SAR _{1g} [mW/g]	Plot #
BT	39	10	8.5	-0.15	Horizontal right	1:1	0.045	1.41	0.06	8

7.2 Simultaneous Transmission Analysis

	Exposure Condition	Head Exposure
	Antenna position	Horizontal right
PCE	GSM850	0.08
	GSM1900	0.12
	WCDMA V	0.13
	WCDMA II	0.30
Maximum PCE SAR		0.30
Maximum DTS SAR		0.06
SAR Summation		0.36
SPLSR Analysis		Σ SAR < 1.6, Analysis Not Required

APPENDIX A: PHOTOS OF THE DUT

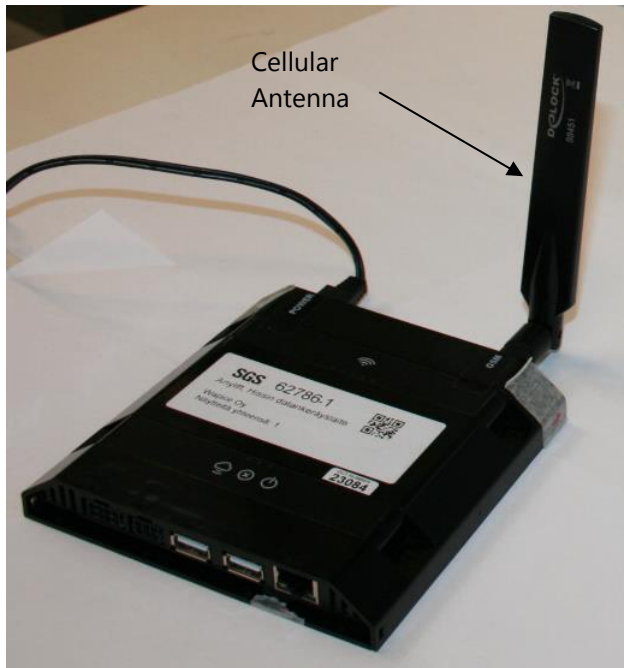

Test position:



APPENDIX B: SYSTEM CHECK SCAN

Plot 1

Date/Time: 2.3.2017 16:30:45

Test Laboratory: Verkotan Oy

DUT: Dipole 835 MHz D835V2; Type: D835V2; Serial: D835V2 - SN:448

Communication System: UID 0, CW (0); Communication System Band: D835 (835.0 MHz); Frequency: 835 MHz; Communication System PAR: 0 dB; PMF: 1

Medium parameters used: $f = 835$ MHz; $\sigma = 0.937$ S/m; $\epsilon_r = 42.222$; $\rho = 1000$ kg/m³

Phantom section: Flat Section

Measurement Standard: DASYS (IEEE/IEC)

DASY Configuration:

- Probe: EX3DV4 - SN3892; ConvF(9.53, 9.53, 9.53); Calibrated: 11.3.2016;
 - Modulation Compensation:
- Sensor-Surface: 2mm (Mechanical Surface Detection), $z = 31.0$
- Electronics: DAE4 Sn1332; Calibrated: 8.3.2016
- Phantom: ELI V5.0 (20deg probe tilt); Type: QD OVA 002 AA; Serial: 1176
- DASYS2 52.8.8(1258); SEMCAD X 14.6.10(7373)

System Performance Check $d=15$ mm, $P_{in}=250$ mW, $dist=2.0$ mm (EX-Probe)/Zoom Scan (7x7x7)

(7x7x7)/Cube 0: Measurement grid: $dx=5$ mm, $dy=5$ mm, $dz=5$ mm

Reference Value = 57.08 V/m; Power Drift = -0.06 dB

Peak SAR (extrapolated) = 3.46 W/kg

SAR(1 g) = 2.3 W/kg; SAR(10 g) = 1.51 W/kg (SAR corrected for target medium)

Maximum value of SAR (measured) = 2.92 W/kg

System Performance Check at Frequencies below 1 GHz/ $d=15$ mm, $P_{in}=250$ mW, $dist=2.0$ mm (EX-Probe)/Area Scan (61x81x1): Interpolated grid: $dx=1.500$ mm, $dy=1.500$ mm

Maximum value of SAR (interpolated) = 2.94 W/kg

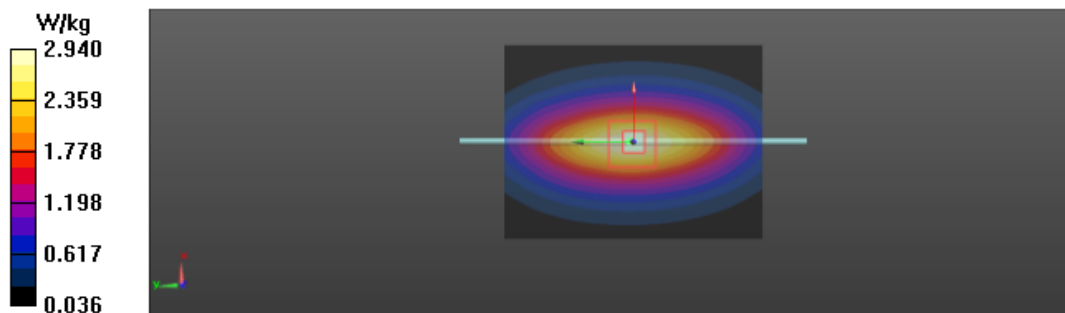

Plot 2

Date/Time: 2.3.2017 17:00:06

Test Laboratory: Verkotan Oy

DUT: Dipole 1900 MHz D1900V2; Type: D1900V2; Serial: D1900V2 - SN:511

Communication System: UID 0, CW (0); Communication System Band: D1900 (1900.0 MHz); Frequency: 1900 MHz; Communication System PAR: 0 dB; PMF: 1

Medium parameters used: $f = 1900$ MHz; $\sigma = 1.467$ S/m; $\epsilon_r = 40.119$; $\rho = 1000$ kg/m³

Phantom section: Flat Section

Measurement Standard: DASY5 (IEEE/IEC)

DASY Configuration:

- Probe: EX3DV4 - SN3892; ConvF(8.02, 8.02, 8.02); Calibrated: 11.3.2016;
 - Modulation Compensation:
- Sensor-Surface: 2mm (Mechanical Surface Detection), $z = 31.0$
- Electronics: DAE4 Sn1332; Calibrated: 8.3.2016
- Phantom: ELI V5.0 (20deg probe tilt); Type: QD OVA 002 AA; Serial: 1176
- DASY52 52.8.8(1258); SEMCAD X 14.6.10(7373)

System Performance Check $d=10$ mm, $P_{in}=250$ mW, $dist=2.0$ mm (EX-Probe)/Zoom Scan (7x7x7)

(7x7x7)/Cube 0: Measurement grid: $dx=5$ mm, $dy=5$ mm, $dz=5$ mm

Reference Value = 97.01 V/m; Power Drift = 0.02 dB

Peak SAR (extrapolated) = 17.4 W/kg

SAR(1 g) = 9.29 W/kg; SAR(10 g) = 4.8 W/kg (SAR corrected for target medium)

Maximum value of SAR (measured) = 13.3 W/kg

System Performance Check $d=10$ mm, $P_{in}=250$ mW, $dist=2.0$ mm (EX-Probe)/Area Scan (71x71x1):

Interpolated grid: $dx=1.200$ mm, $dy=1.200$ mm

Maximum value of SAR (interpolated) = 13.3 W/kg

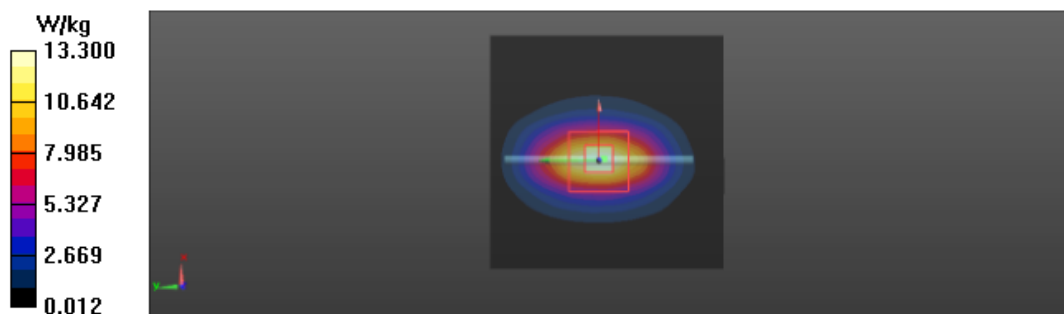

Plot 3

Date/Time: 1.3.2017 10:45:17

Test Laboratory: Verkotan Oy

DUT: Dipole 2450 MHz D2450V2; Type: D2450V2; Serial: D2450V2 - SN:758

Communication System: UID 0, CW (0); Communication System Band: D2450 (2450.0 MHz); Frequency: 2450 MHz; Communication System PAR: 0 dB; PMF: 1

Medium parameters used: $f = 2450$ MHz; $\sigma = 1.858$ S/m; $\epsilon_r = 40.11$; $\rho = 1000$ kg/m³

Phantom section: Flat Section

Measurement Standard: DASYS (IEEE/IEC)

DASY Configuration:

- Probe: EX3DV4 - SN3892; ConvF(7.22, 7.22, 7.22); Calibrated: 11.3.2016;
 - Modulation Compensation:
- Sensor-Surface: 2mm (Mechanical Surface Detection), $z = 31.0$
- Electronics: DAE4 Sn1332; Calibrated: 8.3.2016
- Phantom: ELI V5.0 (20deg probe tilt); Type: QD OVA 002 AA; Serial: 1176
- DASYS2 52.8.8(1258); SEMCAD X 14.6.10(7373)

System Performance Check $d=10$ mm, $P_{in}=250$ mW, $dist=2.0$ mm (EX-Probe)/Zoom Scan (7x7x7)

(7x7x7)/Cube 0: Measurement grid: $dx=5$ mm, $dy=5$ mm, $dz=5$ mm

Reference Value = 102.0 V/m; Power Drift = 0.03 dB

Peak SAR (extrapolated) = 25.2 W/kg

SAR(1 g) = 12.3 W/kg; SAR(10 g) = 5.73 W/kg (SAR corrected for target medium)

Maximum value of SAR (measured) = 18.6 W/kg

System Performance Check $d=10$ mm, $P_{in}=250$ mW, $dist=2.0$ mm (EX-Probe)/Area Scan (71x71x1):

Interpolated grid: $dx=1.200$ mm, $dy=1.200$ mm

Maximum value of SAR (interpolated) = 19.1 W/kg

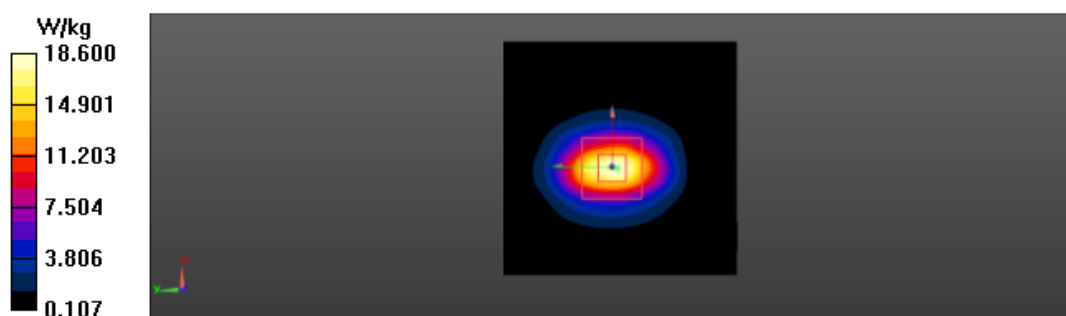

APPENDIX C: MEASUREMENT SCAN

Plot 4

Date/Time: 3.3.2017 11:28:13

Test Laboratory: Verkotan Oy

DUT: KONE Connection 120

Communication System: UID 0, GPRS850 (0); Communication System Band: GPRS850; Frequency: 836.6 MHz; Communication System PAR: 3.263 dB; Medium parameters used: $f = 837$ MHz; $\sigma = 0.938$ S/m; $\epsilon_r = 42.217$; $\rho = 1000$ kg/m³

Phantom section: Flat Section

Measurement Standard: DASYS (IEEE/IEC)

DASY Configuration:

- Probe: EX3DV4 - SN3892; ConvF(9.53, 9.53, 9.53); Calibrated: 11.3.2016;
- Sensor-Surface: 2mm (Mechanical Surface Detection), $z = -9.0, 31.0$
- Electronics: DAE4 Sn1332; Calibrated: 8.3.2016
- Phantom: ELI V5.0 (20deg probe tilt); Type: QD OVA 002 AA; Serial: 1176
- DASYS2 52.8.8(1258); SEMCAD X 14.6.10(7373)

GSM850 4-slot GPRS/Head liquid - CH 190 - Back - Antenna horizontal Right - 5mm/Area Scan

(121x111x1): Interpolated grid: $dx=1.500$ mm, $dy=1.500$ mm

Maximum value of SAR (interpolated) = 0.309 W/kg

GSM850 4-slot GPRS/Head liquid - CH 190 - Back - Antenna horizontal Right - 5mm/Zoom Scan

(9x10x7)/Cube 0: Measurement grid: $dx=5$ mm, $dy=5$ mm, $dz=5$ mm

Reference Value = 18.20 V/m; Power Drift = 0.02 dB

Peak SAR (extrapolated) = 0.362 W/kg

SAR(1 g) = 0.256 W/kg; SAR(10 g) = 0.187 W/kg (SAR corrected for target medium)

Maximum value of SAR (measured) = 0.311 W/kg

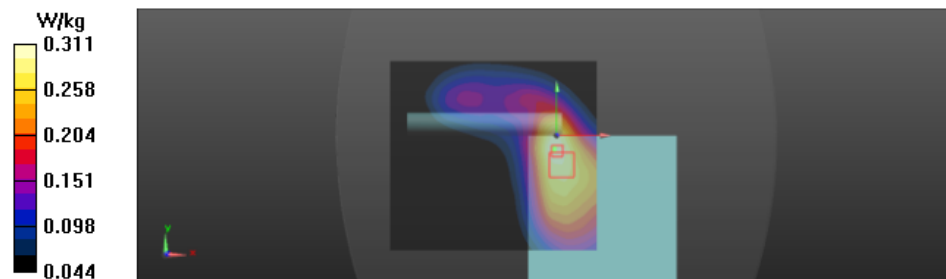

Plot 5

Date/Time: 3.3.2017 10:46:52

Test Laboratory: Verkotan Oy

DUT: KONE Connection 120

Communication System: UID 0, GPRS1900 (0); Communication System Band: GPRS1900; Frequency: 1880 MHz; Communication System PAR: 3.263 dB; PMF

Medium parameters used: $f = 1880$ MHz; $\sigma = 1.455$ S/m; $\epsilon_r = 40.151$; $\rho = 1000$ kg/m³
Phantom section: Flat Section

DASY Configuration:

- Probe: EX3DV4 - SN3892; ConvF(8.02, 8.02, 8.02); Calibrated: 11.3.2016;
- Sensor-Surface: 2mm (Mechanical Surface Detection), $z = -9.0, 31.0$
- Electronics: DAE4 Sn1332; Calibrated: 8.3.2016
- Phantom: ELI V5.0 (20deg probe tilt); Type: QD OVA 002 AA; Serial: 1176
- DASY52 52.8.8(1258); SEMCAD X 14.6.10(7373)

GSM1900 4-slot GPRS/Head liquid - CH 661 - Back - Antenna horizontal Right - 5mm/Area Scan (121x111x1): Interpolated grid: $dx=1.500$ mm, $dy=1.500$ mm
Maximum value of SAR (interpolated) = 0.510 W/kg

GSM1900 4-slot GPRS/Head liquid - CH 661 - Back - Antenna horizontal Right - 5mm/Zoom Scan (7x7x7)/Cube

0: Measurement grid: $dx=5$ mm, $dy=5$ mm, $dz=5$ mm

Reference Value = 15.94 V/m; Power Drift = -0.06 dB

Peak SAR (extrapolated) = 0.632 W/kg

SAR(1 g) = 0.372 W/kg; SAR(10 g) = 0.220 W/kg (SAR corrected for target medium)

Maximum value of SAR (measured) = 0.504 W/kg

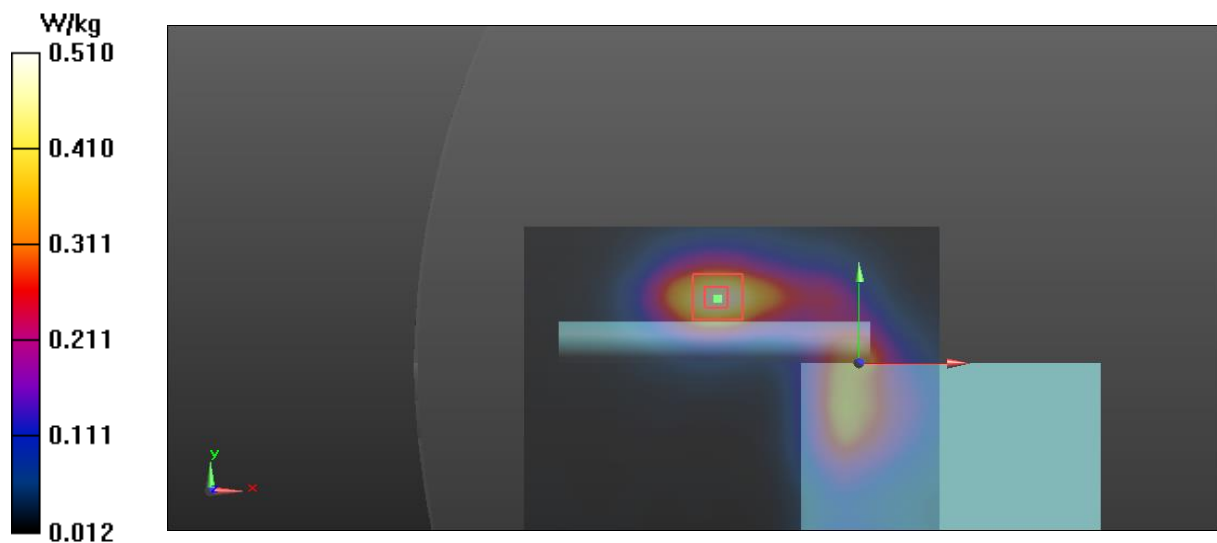

Plot 6

Date/Time: 3.3.2017 12:45:02

Test Laboratory: Verkotan Oy

DUT: KONE Connection 120

Communication System: UID 0, WCDMA (0); Communication System Band: Band 5; Frequency: 836.4 MHz; Communication System PAR: 0 dB; PMF: 1.12202e-005

Medium parameters used (interpolated): $f = 836.4$ MHz; $\sigma = 0.938$ S/m; $\epsilon_r = 42.218$; $\rho = 1000$ kg/m³

Phantom section: Flat Section

Measurement Standard: DASYS (IEEE/IEC)

DASY Configuration:

- Probe: EX3DV4 - SN3892; ConvF(9.53, 9.53, 9.53); Calibrated: 11.3.2016;
- Sensor-Surface: 2mm (Mechanical Surface Detection), $z = 31.0, -9.0$
- Electronics: DAE4 Sn1332; Calibrated: 8.3.2016
- Phantom: ELI V5.0 (20deg probe tilt); Type: QD OVA 002 AA; Serial: 1176
- DASYS 52.8.8(1258); SEMCAD X 14.6.10(7373)

WCDMA850 (Band5)/Head liquid - CH 4182 - Back - Antenna horizontal Right - 5mm/Zoom Scan

(8x9x7)/Cube 0: Measurement grid: $dx=5$ mm, $dy=5$ mm, $dz=5$ mm

Reference Value = 19.82 V/m; Power Drift = -0.07 dB

Peak SAR (extrapolated) = 0.423 W/kg

SAR(1 g) = 0.295 W/kg; SAR(10 g) = 0.214 W/kg (SAR corrected for target medium)

Info: Interpolated medium parameters used for SAR evaluation.

Maximum value of SAR (measured) = 0.360 W/kg

WCDMA850 (Band5)/Head liquid - CH 4182 - Back - Antenna horizontal Right - 5mm/Area Scan

(121x111x1): Interpolated grid: $dx=1.500$ mm, $dy=1.500$ mm

Info: Interpolated medium parameters used for SAR evaluation.

Maximum value of SAR (interpolated) = 0.363 W/kg

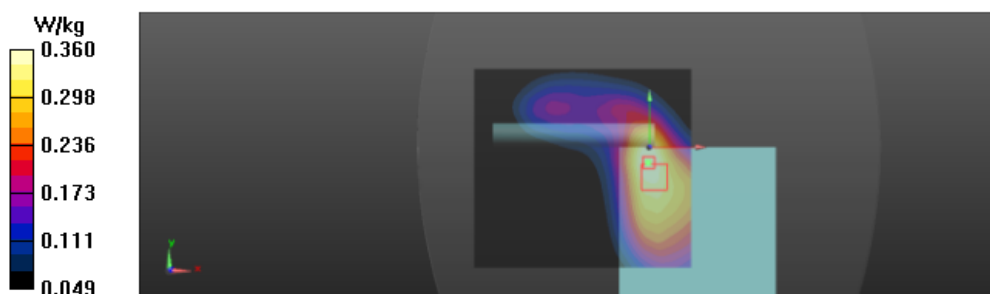

Plot 7

Date/Time: 2.3.2017 21:14:34

Test Laboratory: Verkotan Oy

DUT: KONE Connection 120

Communication System: UID 0, WCDMA (0); Communication System Band: Band 2; Frequency: 1852.5 MHz; Communication System PAR: 0 dB; PMF: 1.12202e-005

Medium parameters used (interpolated): $f = 1852.5$ MHz; $\sigma = 1.441$ S/m; $\epsilon_r = 40.177$; $\rho = 1000$ kg/m³

Phantom section: Flat Section

DASY Configuration:

- Probe: EX3DV4 - SN3892; ConvF(8.02, 8.02, 8.02); Calibrated: 11.3.2016;
 - Modulation Compensation:
- Sensor-Surface: 2mm (Mechanical Surface Detection), Sensor-Surface: 2mm (Mechanical Surface Detection (Locations From Previous Scan Used)), $z = 31.0, -9.0$
- Electronics: DAE4 Sn1332; Calibrated: 8.3.2016
- Phantom: ELI V5.0 (20deg probe tilt); Type: QD OVA 002 AA; Serial: 1176
- DASY52 52.8.8(1258); SEMCAD X 14.6.10(7373)

WCDMA1900 (Band2)/Head liquid - CH 9262 - Back - Antenna horizontal Right - 5mm/Zoom Scan

(8x7x7)/Cube 0: Measurement grid: $dx=5$ mm, $dy=5$ mm, $dz=5$ mm

Reference Value = 21.46 V/m; Power Drift = 0.04 dB

Peak SAR (extrapolated) = 1.71 W/kg

SAR(1 g) = 0.999 W/kg; SAR(10 g) = 0.581 W/kg (SAR corrected for target medium)

Info: [Interpolated medium parameters used for SAR evaluation.](#)

Maximum value of SAR (measured) = 1.36 W/kg

WCDMA1900 (Band2)/Head liquid - CH 9262 - Back - Antenna horizontal Right - 5mm/Area Scan

(181x141x1): Interpolated grid: $dx=1.500$ mm, $dy=1.500$ mm

Info: [Interpolated medium parameters used for SAR evaluation.](#)

Maximum value of SAR (interpolated) = 1.35 W/kg

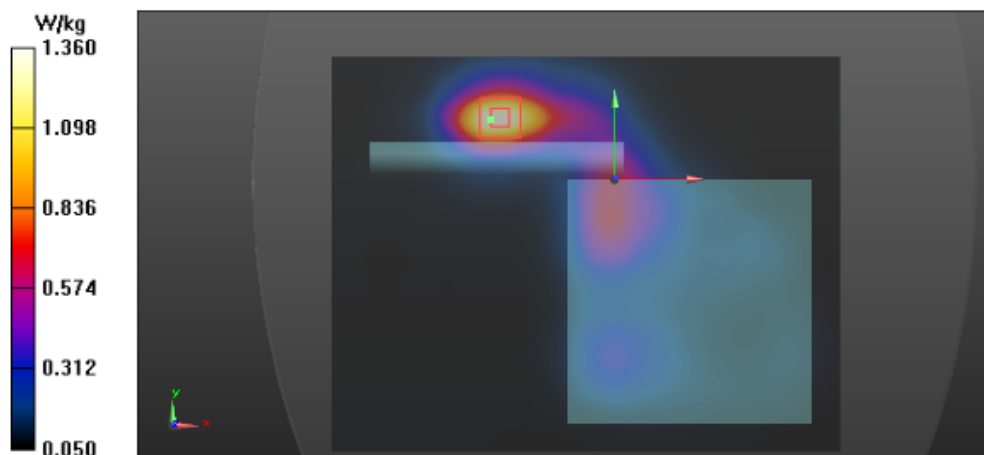

Plot 8

Date/Time: 1.3.2017 18:19:42

Test Laboratory: Verkotan Oy

DUT: KONE Connection 120

Communication System: UID 0, Bluetooth (0); Communication System Band: Bluetooth; Frequency: 2441 MHz; Communication System PAR: 0 dB; PMF: 1

Medium parameters used: $f = 2441$ MHz; $\sigma = 1.851$ S/m; $\epsilon_r = 40.132$; $\rho = 1000$ kg/m³

Phantom section: Flat Section

Measurement Standard: DASYS (IEEE/IEC)

DASY Configuration:

- Probe: EX3DV4 - SN3892; ConvF(7.22, 7.22, 7.22); Calibrated: 11.3.2016;
 - Modulation Compensation:
- Sensor-Surface: 2mm (Mechanical Surface Detection), $z = -9.0, 31.0$
- Electronics: DAE4 Sn1332; Calibrated: 8.3.2016
- Phantom: ELI V5.0 (20deg probe tilt); Type: QD OVA 002 AA; Serial: 1176
- DASYS2 52.8.8(1258); SEMCAD X 14.6.10(7373)

Bluetooth/5mm - Head liquid - CH 38 - Back - Antenna horizontal Right/Area Scan (211x211x1):

Interpolated grid: $dx=1.000$ mm, $dy=1.000$ mm

Maximum value of SAR (interpolated) = 0.0514 W/kg

Bluetooth/5mm - Head liquid - CH 38 - Back - Antenna horizontal Right/Zoom Scan (8x8x7)/Cube 0:

Measurement grid: $dx=5$ mm, $dy=5$ mm, $dz=5$ mm

Reference Value = 3.532 V/m; Power Drift = -0.15 dB

Peak SAR (extrapolated) = 0.0670 W/kg

SAR(1 g) = 0.045 W/kg; SAR(10 g) = 0.038 W/kg (SAR corrected for target medium)

Maximum value of SAR (measured) = 0.0674 W/kg

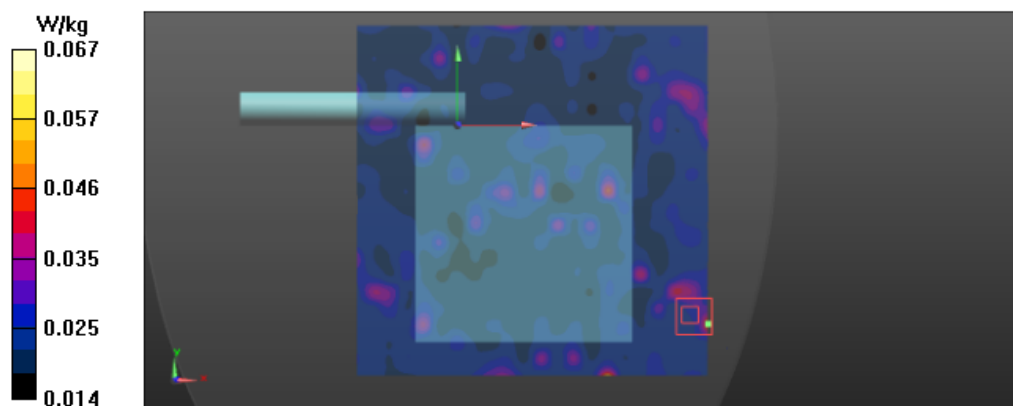

APPENDIX D: RELEVANT PAGES FROM PROBE CALIBRATION REPORTS

**Calibration Laboratory of
Schmid & Partner
Engineering AG**
Zeughausstrasse 43, 8004 Zurich, Switzerland



S Schweizerischer Kalibrierdienst
C Service suisse d'étalonnage
S Servizio svizzero di taratura
S Swiss Calibration Service

Accredited by the Swiss Accreditation Service (SAS)
The Swiss Accreditation Service is one of the signatories to the EA
Multilateral Agreement for the recognition of calibration certificates

Accreditation No.: **SCS 0108**

Client **TCC Microsoft**

Certificate No: **EX3-3892_Mar16**

CALIBRATION CERTIFICATE

Object: **EX3DV4 - SN:3892**

Calibration procedure(s): **QA CAL-01.v9, QA CAL-14.v4, QA CAL-23.v5, QA CAL-25.v6
Calibration procedure for dosimetric E-field probes**

Calibration date: **March 11, 2016**

This calibration certificate documents the traceability to national standards, which realize the physical units of measurements (SI).
The measurements and the uncertainties with confidence probability are given on the following pages and are part of the certificate.

All calibrations have been conducted in the closed laboratory facility: environment temperature (22 ± 3)°C and humidity < 70%.

Calibration Equipment used (M&TE critical for calibration)

Primary Standards	ID	Cal Date (Certificate No.)	Scheduled Calibration
Power meter E4419B	GB41293874	01-Apr-15 (No. 217-02128)	Mar-16
Power sensor E4412A	MY41498087	01-Apr-15 (No. 217-02128)	Mar-16
Reference 3 dB Attenuator	SN: S5054 (3c)	01-Apr-15 (No. 217-02129)	Mar-16
Reference 20 dB Attenuator	SN: S5277 (20x)	01-Apr-15 (No. 217-02132)	Mar-16
Reference 30 dB Attenuator	SN: S5129 (30b)	01-Apr-15 (No. 217-02133)	Mar-16
Reference Probe ES3DV2	SN: 3013	31-Dec-15 (No. ES3-3013_Dec15)	Dec-16
DAE4	SN: 660	23-Dec-15 (No. DAE4-660_Dec15)	Dec-16
Secondary Standards	ID	Check Date (in house)	Scheduled Check
RF generator HP 8648C	US3642U01700	4-Aug-99 (in house check Apr-13)	In house check: Apr-16
Network Analyzer HP 8753E	US37390585	18-Oct-01 (in house check Oct-15)	In house check: Oct-16

	Name	Function	Signature
Calibrated by:	Leif Klynsner	Laboratory Technician	
Approved by:	Katja Pokovic	Technical Manager	

Issued: March 12, 2016

This calibration certificate shall not be reproduced except in full without written approval of the laboratory.

EX3DV4- SN:3892

March 11, 2016

DASY/EASY - Parameters of Probe: EX3DV4 - SN:3892

Basic Calibration Parameters

	Sensor X	Sensor Y	Sensor Z	Unc (k=2)
Norm ($\mu\text{V}/(\text{V}/\text{m})^2$) ^A	0.50	0.40	0.49	$\pm 10.1 \%$
DCP (mV) ^B	102.2	104.7	101.9	

Modulation Calibration Parameters

UID	Communication System Name		A dB	B dB $\sqrt{\mu\text{V}}$	C	D dB	VR mV	Unc ^E (k=2)
0	CW	X	0.0	0.0	1.0	0.00	137.0	$\pm 3.8 \%$
		Y	0.0	0.0	1.0		142.9	
		Z	0.0	0.0	1.0		137.5	

The reported uncertainty of measurement is stated as the standard uncertainty of measurement multiplied by the coverage factor $k=2$, which for a normal distribution corresponds to a coverage probability of approximately 95%.

^A The uncertainties of Norm X,Y,Z do not affect the E^2 -field uncertainty inside TSL (see Pages 5 and 6).

^B Numerical linearization parameter: uncertainty not required.

^E Uncertainty is determined using the max. deviation from linear response applying rectangular distribution and is expressed for the square of the field value.

EX3DV4– SN:3892

March 11, 2016

DASY/EASY - Parameters of Probe: EX3DV4 - SN:3892

Calibration Parameter Determined in Head Tissue Simulating Media

f (MHz) ^C	Relative Permittivity ^F	Conductivity (S/m) ^F	ConvF X	ConvF Y	ConvF Z	Alpha ^G	Depth ^G (mm)	Unc (k=2)
750	41.9	0.89	10.08	10.08	10.08	0.41	0.88	± 12.0 %
835	41.5	0.90	9.53	9.53	9.53	0.41	0.80	± 12.0 %
1750	40.1	1.37	8.32	8.32	8.32	0.32	0.80	± 12.0 %
1900	40.0	1.40	8.02	8.02	8.02	0.32	0.80	± 12.0 %
2300	39.5	1.67	7.54	7.54	7.54	0.31	0.80	± 12.0 %
2450	39.2	1.80	7.22	7.22	7.22	0.27	0.97	± 12.0 %
2600	39.0	1.96	7.08	7.08	7.08	0.30	0.95	± 12.0 %
5250	35.9	4.71	4.79	4.79	4.79	0.35	1.80	± 13.1 %
5600	35.5	5.07	4.37	4.37	4.37	0.45	1.80	± 13.1 %
5750	35.4	5.22	4.53	4.53	4.53	0.45	1.80	± 13.1 %

^C Frequency validity above 300 MHz of ± 100 MHz only applies for DASY v4.4 and higher (see Page 2), else it is restricted to ± 50 MHz. The uncertainty is the RSS of the ConvF uncertainty at calibration frequency and the uncertainty for the indicated frequency band. Frequency validity below 300 MHz is ± 10, 25, 40, 50 and 70 MHz for ConvF assessments at 30, 64, 128, 150 and 220 MHz respectively. Above 5 GHz frequency validity can be extended to ± 110 MHz.

^F At frequencies below 3 GHz, the validity of tissue parameters (ϵ and σ) can be relaxed to ± 10% if liquid compensation formula is applied to measured SAR values. At frequencies above 3 GHz, the validity of tissue parameters (ϵ and σ) is restricted to ± 5%. The uncertainty is the RSS of the ConvF uncertainty for indicated target tissue parameters.

^G Alpha/Depth are determined during calibration. SPEAG warrants that the remaining deviation due to the boundary effect after compensation is always less than ± 1% for frequencies below 3 GHz and below ± 2% for frequencies between 3-6 GHz at any distance larger than half the probe tip diameter from the boundary.

APPENDIX E: RELEVANT PAGES FROM DIPOLE CALIBRATION REPORTS

Calibration Laboratory of
Schmid & Partner
Engineering AG
Zeughausstrasse 43, 8004 Zurich, Switzerland



S Schweizerischer Kalibrierdienst
C Service suisse d'étalonnage
S Servizio svizzero di taratura
S Swiss Calibration Service

Accredited by the Swiss Accreditation Service (SAS)
The Swiss Accreditation Service is one of the signatories to the EA
Multilateral Agreement for the recognition of calibration certificates

Accreditation No.: SCS 0108

Client **Verkotan**

Certificate No: D835V2-448_Jan16

CALIBRATION CERTIFICATE

Object **D835V2 - SN: 448**

Calibration procedure(s) **QA CAL-05.v9
Calibration procedure for dipole validation kits above 700 MHz**

Calibration date: **January 15, 2016**

This calibration certificate documents the traceability to national standards, which realize the physical units of measurements (SI).
The measurements and the uncertainties with confidence probability are given on the following pages and are part of the certificate.

All calibrations have been conducted in the closed laboratory facility: environment temperature (22 ± 3)°C and humidity < 70%.

Calibration Equipment used (M&TE critical for calibration)

Primary Standards	ID #	Cal Date (Certificate No.)	Scheduled Calibration
Power meter EPM-442A	GB37480704	07-Oct-15 (No. 217-02222)	Oct-16
Power sensor HP 8481A	US37292783	07-Oct-15 (No. 217-02222)	Oct-16
Power sensor HP 8481A	MY41092317	07-Oct-15 (No. 217-02223)	Oct-16
Reference 20 dB Attenuator	SN: 5058 (20k)	01-Apr-15 (No. 217-02131)	Mar-16
Type-N mismatch combination	SN: 5047.2 / 06327	01-Apr-15 (No. 217-02134)	Mar-16
Reference Probe EX3DV4	SN: 7349	31-Dec-15 (No. EX3-7349_Dec15)	Dec-16
DAE4	SN: 601	30-Dec-15 (No. DAE4-601_Dec15)	Dec-16
Secondary Standards	ID #	Check Date (in house)	Scheduled Check
RF generator R&S SMT-06	100972	15-Jun-15 (in house check Jun-15)	In house check: Jun-18
Network Analyzer HP 8753E	US37390585 S4206	18-Oct-01 (in house check Oct-15)	In house check: Oct-16

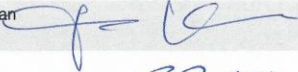
Calibrated by: **Jeton Kastrati** (Name), **Laboratory Technician** (Function),  (Signature)

Approved by: **Katja Pokovic** (Name), **Technical Manager** (Function),  (Signature)

Issued: January 15, 2016

This calibration certificate shall not be reproduced except in full without written approval of the laboratory.

Measurement Conditions

DASY system configuration, as far as not given on page 1.

DASY Version	DASY5	V52.8.8
Extrapolation	Advanced Extrapolation	
Phantom	Modular Flat Phantom	
Distance Dipole Center - TSL	15 mm	with Spacer
Zoom Scan Resolution	dx, dy, dz = 5 mm	
Frequency	835 MHz \pm 1 MHz	

Head TSL parameters

The following parameters and calculations were applied.

	Temperature	Permittivity	Conductivity
Nominal Head TSL parameters	22.0 °C	41.5	0.90 mho/m
Measured Head TSL parameters	(22.0 \pm 0.2) °C	42.0 \pm 6 %	0.93 mho/m \pm 6 %
Head TSL temperature change during test	< 0.5 °C	----	----

SAR result with Head TSL

SAR averaged over 1 cm ³ (1 g) of Head TSL	Condition	
SAR measured	250 mW input power	2.37 W/kg
SAR for nominal Head TSL parameters	normalized to 1W	9.27 W/kg \pm 17.0 % (k=2)

SAR averaged over 10 cm ³ (10 g) of Head TSL	condition	
SAR measured	250 mW input power	1.53 W/kg
SAR for nominal Head TSL parameters	normalized to 1W	6.01 W/kg \pm 16.5 % (k=2)

Body TSL parameters

The following parameters and calculations were applied.

	Temperature	Permittivity	Conductivity
Nominal Body TSL parameters	22.0 °C	55.2	0.97 mho/m
Measured Body TSL parameters	(22.0 \pm 0.2) °C	55.2 \pm 6 %	1.01 mho/m \pm 6 %
Body TSL temperature change during test	< 0.5 °C	----	----

SAR result with Body TSL

SAR averaged over 1 cm ³ (1 g) of Body TSL	Condition	
SAR measured	250 mW input power	2.46 W/kg
SAR for nominal Body TSL parameters	normalized to 1W	9.55 W/kg \pm 17.0 % (k=2)

SAR averaged over 10 cm ³ (10 g) of Body TSL	condition	
SAR measured	250 mW input power	1.61 W/kg
SAR for nominal Body TSL parameters	normalized to 1W	6.29 W/kg \pm 16.5 % (k=2)

**Calibration Laboratory of
Schmid & Partner
Engineering AG**
Zeughausstrasse 43, 8004 Zurich, Switzerland



S Schweizerischer Kalibrierdienst
C Service suisse d'étalonnage
S Servizio svizzero di taratura
S Swiss Calibration Service

Accredited by the Swiss Accreditation Service (SAS)

Accreditation No.: **SCS 0108**

The Swiss Accreditation Service is one of the signatories to the EA Multilateral Agreement for the recognition of calibration certificates

Client **Verkotan**

Certificate No: **D1900V2-511_Jan16**

CALIBRATION CERTIFICATE

Object: **D1900V2 - SN: 511**

Calibration procedure(s): **QA CAL-05.v9
Calibration procedure for dipole validation kits above 700 MHz**

Calibration date: **January 14, 2016**

This calibration certificate documents the traceability to national standards, which realize the physical units of measurements (SI). The measurements and the uncertainties with confidence probability are given on the following pages and are part of the certificate.

All calibrations have been conducted in the closed laboratory facility: environment temperature (22 ± 3)°C and humidity < 70%.

Calibration Equipment used (M&TE critical for calibration)

Primary Standards	ID #	Cal Date (Certificate No.)	Scheduled Calibration
Power meter EPM-442A	GB37480704	07-Oct-15 (No. 217-02222)	Oct-16
Power sensor HP 8481A	US37292783	07-Oct-15 (No. 217-02222)	Oct-16
Power sensor HP 8481A	MY41092317	07-Oct-15 (No. 217-02223)	Oct-16
Reference 20 dB Attenuator	SN: 5058 (20k)	01-Apr-15 (No. 217-02131)	Mar-16
Type-N mismatch combination	SN: 5047.2 / 06327	01-Apr-15 (No. 217-02134)	Mar-16
Reference Probe EX3DV4	SN: 7349	31-Dec-15 (No. EX3-7349_Dec15)	Dec-16
DAE4	SN: 601	30-Dec-15 (No. DAE4-601_Dec15)	Dec-16

Secondary Standards	ID #	Check Date (in house)	Scheduled Check
RF generator R&S SMT-06	100972	15-Jun-15 (in house check Jun-15)	In house check: Jun-18
Network Analyzer HP 8753E	US37390585 S4206	18-Oct-01 (in house check Oct-15)	In house check: Oct-16

Calibrated by:	Name Michael Weber	Function Laboratory Technician	Signature
Approved by:	Name Katja Pokovic	Function Technical Manager	Signature

Issued: January 15, 2016

This calibration certificate shall not be reproduced except in full without written approval of the laboratory.

Measurement Conditions

DASY system configuration, as far as not given on page 1.

DASY Version	DASY5	V52.8.8
Extrapolation	Advanced Extrapolation	
Phantom	Modular Flat Phantom	
Distance Dipole Center - TSL	10 mm	with Spacer
Zoom Scan Resolution	dx, dy, dz = 5 mm	
Frequency	1900 MHz \pm 1 MHz	

Head TSL parameters

The following parameters and calculations were applied.

	Temperature	Permittivity	Conductivity
Nominal Head TSL parameters	22.0 °C	40.0	1.40 mho/m
Measured Head TSL parameters	(22.0 \pm 0.2) °C	39.3 \pm 6 %	1.39 mho/m \pm 6 %
Head TSL temperature change during test	< 0.5 °C	----	----

SAR result with Head TSL

SAR averaged over 1 cm ³ (1 g) of Head TSL	Condition	
SAR measured	250 mW input power	9.73 W/kg
SAR for nominal Head TSL parameters	normalized to 1W	38.9 W/kg \pm 17.0 % (k=2)

SAR averaged over 10 cm ³ (10 g) of Head TSL	condition	
SAR measured	250 mW input power	5.12 W/kg
SAR for nominal Head TSL parameters	normalized to 1W	20.5 W/kg \pm 16.5 % (k=2)

Body TSL parameters

The following parameters and calculations were applied.

	Temperature	Permittivity	Conductivity
Nominal Body TSL parameters	22.0 °C	53.3	1.52 mho/m
Measured Body TSL parameters	(22.0 \pm 0.2) °C	52.7 \pm 6 %	1.52 mho/m \pm 6 %
Body TSL temperature change during test	< 0.5 °C	----	----

SAR result with Body TSL

SAR averaged over 1 cm ³ (1 g) of Body TSL	Condition	
SAR measured	250 mW input power	10.1 W/kg
SAR for nominal Body TSL parameters	normalized to 1W	40.3 W/kg \pm 17.0 % (k=2)

SAR averaged over 10 cm ³ (10 g) of Body TSL	condition	
SAR measured	250 mW input power	5.34 W/kg
SAR for nominal Body TSL parameters	normalized to 1W	21.3 W/kg \pm 16.5 % (k=2)

**Calibration Laboratory of
Schmid & Partner
Engineering AG**
Zeughausstrasse 43, 8004 Zurich, Switzerland



S Schweizerischer Kalibrierdienst
C Service suisse d'étalonnage
S Servizio svizzero di taratura
S Swiss Calibration Service

Accredited by the Swiss Accreditation Service (SAS)
The Swiss Accreditation Service is one of the signatories to the EA
Multilateral Agreement for the recognition of calibration certificates

Accreditation No.: **SCS 0108**

Client **Verkotan**

Certificate No: **D2450V2-758_Jan16**

CALIBRATION CERTIFICATE

Object: **D2450V2 - SN: 758**

Calibration procedure(s): **QA CAL-05.v9
Calibration procedure for dipole validation kits above 700 MHz**

Calibration date: **January 14, 2016**

This calibration certificate documents the traceability to national standards, which realize the physical units of measurements (SI).
The measurements and the uncertainties with confidence probability are given on the following pages and are part of the certificate.

All calibrations have been conducted in the closed laboratory facility: environment temperature (22 ± 3)°C and humidity < 70%.

Calibration Equipment used (M&TE critical for calibration)

Primary Standards	ID #	Cal Date (Certificate No.)	Scheduled Calibration
Power meter EPM-442A	GB37480704	07-Oct-15 (No. 217-02222)	Oct-16
Power sensor HP 8481A	US37292783	07-Oct-15 (No. 217-02222)	Oct-16
Power sensor HP 8481A	MY41092317	07-Oct-15 (No. 217-02223)	Oct-16
Reference 20 dB Attenuator	SN: 5058 (20k)	01-Apr-15 (No. 217-02131)	Mar-16
Type-N mismatch combination	SN: 5047.2 / 06327	01-Apr-15 (No. 217-02134)	Mar-16
Reference Probe EX3DV4	SN: 7349	31-Dec-15 (No. EX3-7349_Dec15)	Dec-16
DAE4	SN: 601	30-Dec-15 (No. DAE4-601_Dec15)	Dec-16
Secondary Standards	ID #	Check Date (in house)	Scheduled Check
RF generator R&S SMT-06	100972	15-Jun-15 (in house check Jun-15)	In house check: Jun-18
Network Analyzer HP 8753E	US37390585 S4206	18-Oct-01 (in house check Oct-15)	In house check: Oct-16

	Name	Function	Signature
Calibrated by:	Michael Weber	Laboratory Technician	
Approved by:	Katja Pokovic	Technical Manager	

Issued: January 15, 2016

This calibration certificate shall not be reproduced except in full without written approval of the laboratory.

Measurement Conditions

DASY system configuration, as far as not given on page 1.

DASY Version	DASY5	V52.8.8
Extrapolation	Advanced Extrapolation	
Phantom	Modular Flat Phantom	
Distance Dipole Center - TSL	10 mm	with Spacer
Zoom Scan Resolution	dx, dy, dz = 5 mm	
Frequency	2450 MHz \pm 1 MHz	

Head TSL parameters

The following parameters and calculations were applied.

	Temperature	Permittivity	Conductivity
Nominal Head TSL parameters	22.0 °C	39.2	1.80 mho/m
Measured Head TSL parameters	(22.0 \pm 0.2) °C	37.8 \pm 6 %	1.87 mho/m \pm 6 %
Head TSL temperature change during test	< 0.5 °C	----	----

SAR result with Head TSL

SAR averaged over 1 cm ³ (1 g) of Head TSL	Condition	
SAR measured	250 mW input power	13.2 W/kg
SAR for nominal Head TSL parameters	normalized to 1W	51.4 W/kg \pm 17.0 % (k=2)

SAR averaged over 10 cm ³ (10 g) of Head TSL	condition	
SAR measured	250 mW input power	6.12 W/kg
SAR for nominal Head TSL parameters	normalized to 1W	24.1 W/kg \pm 16.5 % (k=2)

Body TSL parameters

The following parameters and calculations were applied.

	Temperature	Permittivity	Conductivity
Nominal Body TSL parameters	22.0 °C	52.7	1.95 mho/m
Measured Body TSL parameters	(22.0 \pm 0.2) °C	52.1 \pm 6 %	2.04 mho/m \pm 6 %
Body TSL temperature change during test	< 0.5 °C	----	----

SAR result with Body TSL

SAR averaged over 1 cm ³ (1 g) of Body TSL	Condition	
SAR measured	250 mW input power	13.1 W/kg
SAR for nominal Body TSL parameters	normalized to 1W	51.2 W/kg \pm 17.0 % (k=2)

SAR averaged over 10 cm ³ (10 g) of Body TSL	condition	
SAR measured	250 mW input power	6.14 W/kg
SAR for nominal Body TSL parameters	normalized to 1W	24.2 W/kg \pm 16.5 % (k=2)

APPENDIX F FAST SAR RESULTS

Date/Time: 2.3.2017 17:36:36

Test Laboratory: Verkotan Oy

Antenna horizontal straight

Communication System: UID 0, WCDMA (0); Communication System Band: Band 5; Frequency: 836.4 MHz; Communication System PAR: 0 dB; PMF: 1.12202e-005
 Medium parameters used (interpolated): $f = 836.4$ MHz; $\sigma = 0.938$ S/m; $\epsilon_r = 42.218$; $\rho = 1000$ kg/m³
 Phantom section: Flat Section
 Measurement Standard: DASYS (IEEE/IEC/ANSI C63.19-2011)

DASY Configuration:

- Probe: EX3DV4 - SN3892; ConvF(9.53, 9.53, 9.53); Calibrated: 11.3.2016;
 - Modulation Compensation:
- Sensor-Surface: 2mm (Mechanical Surface Detection), $z = 1.0$
- Electronics: DAE4 Sn1332; Calibrated: 8.3.2016
- Phantom: ELI V5.0 (20deg probe tilt); Type: QD OVA 002 AA; Serial: 1176
- DASYS2 52.8.8(1258); SEMCAD X 14.6.10(7373)

WCDMA850 (Band5) - Hotspot check - Head liquid - CH 4182 - Back - Antenna horizontal straight - 5mm/Area Scan (61x111x1): Interpolated grid: $dx=3.000$ mm, $dy=3.000$ mm

[Info: Interpolated medium parameters used for SAR evaluation.](#)

Maximum value of SAR (interpolated) = 0.328 W/kg

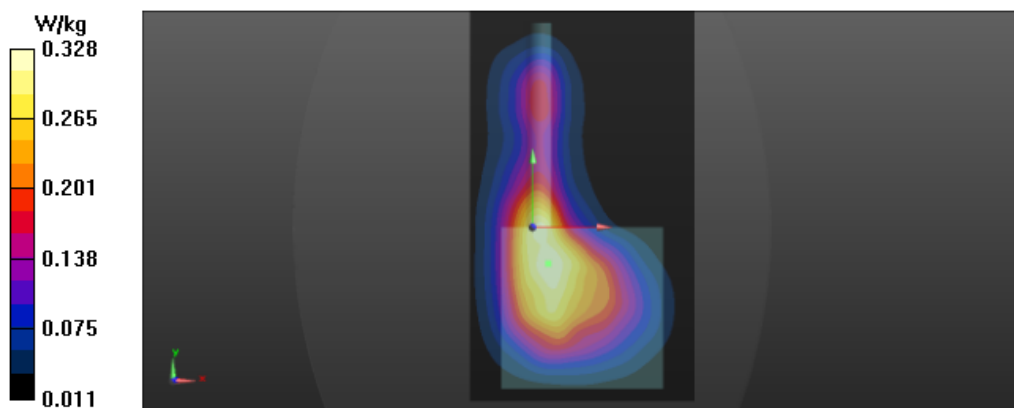

Date/Time: 2.3.2017 17:47:58

Test Laboratory: Verkotan Oy

Antenna horizontal Right

Communication System: UID 0, WCDMA (0); Communication System Band: Band 5; Frequency: 836.4 MHz; Communication System PAR: 0 dB; PMF: 1.12202e-005

Medium parameters used (interpolated): $f = 836.4$ MHz; $\sigma = 0.938$ S/m; $\epsilon_r = 42.218$; $\rho = 1000$ kg/m³

Phantom section: Flat Section

Measurement Standard: DASYS (IEEE/IEC/ANSI C63.19-2011)

DASY Configuration:

- Probe: EX3DV4 - SN3892; ConvF(9.53, 9.53, 9.53); Calibrated: 11.3.2016;
 - Modulation Compensation:
- Sensor-Surface: 2mm (Mechanical Surface Detection), $z = -9.0$
- Electronics: DAE4 Sn1332; Calibrated: 8.3.2016
- Phantom: ELI V5.0 (20deg probe tilt); Type: QD OVA 002 AA; Serial: 1176
- DASYS2 52.8.8(1258); SEMCAD X 14.6.10(7373)

WCDMA850 (Band5) - Hotspot check - Head liquid - CH 4182 - Back - Antenna horizontal Right - 5mm/Area Scan (91x71x1): Interpolated grid: $dx=3.000$ mm, $dy=3.000$ mm

[Info: Interpolated medium parameters used for SAR evaluation.](#)

Maximum value of SAR (interpolated) = 0.357 W/kg

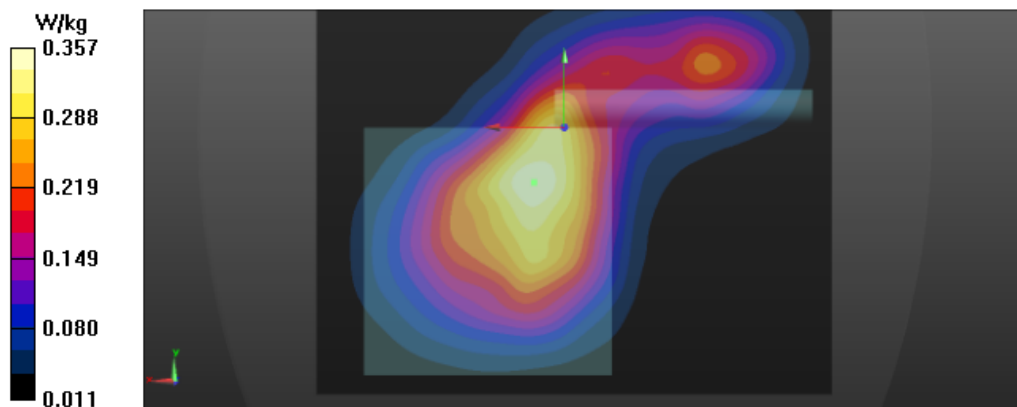

Date/Time: 2.3.2017 17:59:54

Test Laboratory: Verkotan Oy

Antenna horizontal Left

Communication System: UID 0, WCDMA (0); Communication System Band: Band 5; Frequency: 836.4 MHz; Communication System PAR: 0 dB; PMF: 1.12202e-005

Medium parameters used (interpolated): $f = 836.4$ MHz; $\sigma = 0.938$ S/m; $\epsilon_r = 42.218$; $\rho = 1000$ kg/m³

Phantom section: Flat Section

Measurement Standard: DASYS (IEEE/IEC/ANSI C63.19-2011)

DASY Configuration:

- Probe: EX3DV4 - SN3892; ConvF(9.53, 9.53, 9.53); Calibrated: 11.3.2016;
 - Modulation Compensation:
- Sensor-Surface: 2mm (Mechanical Surface Detection), $z = -9.0$
- Electronics: DAE4 Sn1332; Calibrated: 8.3.2016
- Phantom: ELI V5.0 (20deg probe tilt); Type: QD OVA 002 AA; Serial: 1176
- DASYS2 52.8.8(1258); SEMCAD X 14.6.10(7373)

WCDMA850 (Band5) - Hotspot check - Head liquid - CH 4182 - Back - Antenna horizontal Left - 5mm/Area Scan (71x71x1): Interpolated grid: $dx=3.000$ mm, $dy=3.000$ mm

Info: Interpolated medium parameters used for SAR evaluation.

Maximum value of SAR (interpolated) = 0.350 W/kg

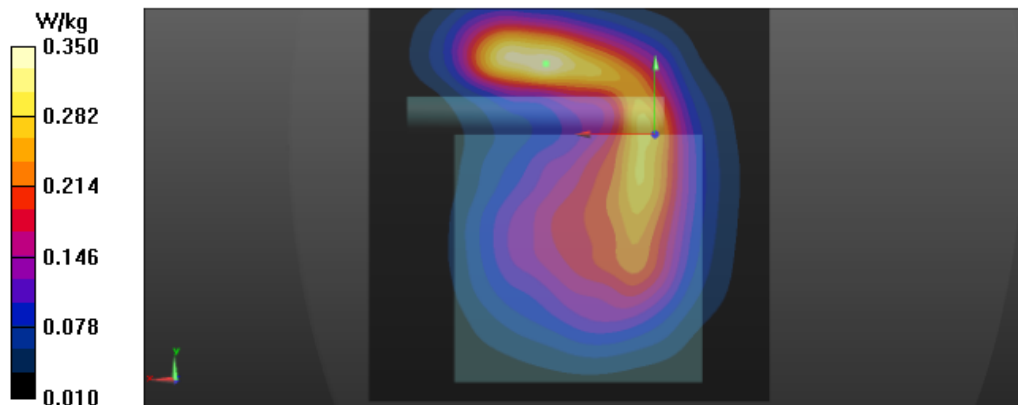

Date/Time: 2.3.2017 18:09:18

Test Laboratory: Verkotan Oy

Antenna vertical

Communication System: UID 0, WCDMA (0); Communication System Band: Band 5; Frequency: 836.4 MHz; Communication System PAR: 0 dB; PMF: 1.12202e-005

Medium parameters used (interpolated): $f = 836.4$ MHz; $\sigma = 0.938$ S/m; $\epsilon_r = 42.218$; $\rho = 1000$ kg/m³

Phantom section: Flat Section

Measurement Standard: DASY5 (IEEE/IEC/ANSI C63.19-2011)

DASY Configuration:

- Probe: EX3DV4 - SN3892; ConvF(9.53, 9.53, 9.53); Calibrated: 11.3.2016;
 - Modulation Compensation:
- Sensor-Surface: 2mm (Mechanical Surface Detection (Locations From Previous Scan Used)), $z = -9.0$
- Electronics: DAE4 Sn1332; Calibrated: 8.3.2016
- Phantom: ELI V5.0 (20deg probe tilt); Type: QD OVA 002 AA; Serial: 1176
- DASY52 52.8.8(1258); SEMCAD X 14.6.10(7373)

WCDMA850 (Band5) - Hotspot check - Head liquid - CH 4182 - Back - Antenna vertical - 5mm/Area Scan (71x71x1): Interpolated grid: $dx=3.000$ mm, $dy=3.000$ mm

[Info: Interpolated medium parameters used for SAR evaluation.](#)

Maximum value of SAR (interpolated) = 0.186 W/kg

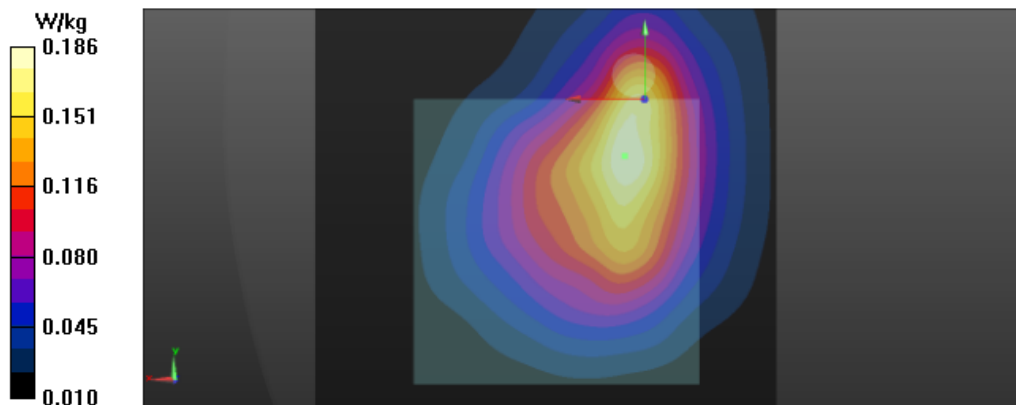

Date/Time: 2.3.2017 19:48:41

Test Laboratory: Verkotan Oy

Antenna horizontal Right

Communication System: UID 0, WCDMA (0); Communication System Band: Band 2; Frequency: 1880

MHz; Communication System PAR: 0 dB; PMF: 1.12202e-005

Medium parameters used: $f = 1880$ MHz; $\sigma = 1.455$ S/m; $\epsilon_r = 40.151$; $\rho = 1000$ kg/m³

Phantom section: Flat Section

Measurement Standard: DASYS (IEEE/IEC/ANSI C63.19-2011)

DASY Configuration:

- Probe: EX3DV4 - SN3892; ConvF(8.02, 8.02, 8.02); Calibrated: 11.3.2016;
 - Modulation Compensation:
- Sensor-Surface: 2mm (Mechanical Surface Detection), $z = -9.0$
- Electronics: DAE4 Sn1332; Calibrated: 8.3.2016
- Phantom: ELI V5.0 (20deg probe tilt); Type: QD OVA 002 AA; Serial: 1176
- DASYS2 52.8.8(1258); SEMCAD X 14.6.10(7373)

WCDMA1900 (Band2) - Hotspot check - Head liquid - CH 9400 - Back - Antenna horizontal Right - 5mm/Area Scan (91x71x1): Interpolated grid: $dx=3.000$ mm, $dy=3.000$ mm

Maximum value of SAR (interpolated) = 1.09 W/kg

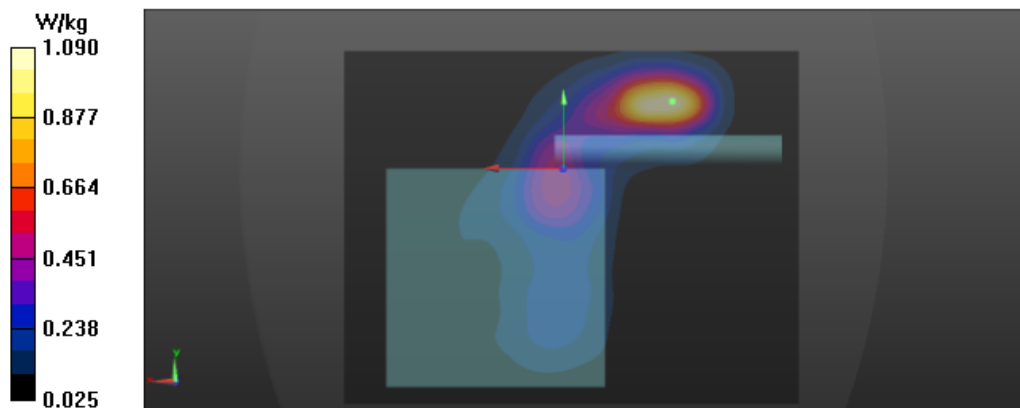

Date/Time: 2.3.2017 19:38:47

Test Laboratory: Verkotan Oy

Antenna horizontal straight

Communication System: UID 0, WCDMA (0); Communication System Band: Band 2; Frequency: 1880 MHz; Communication System PAR: 0 dB; PMF: 1.12202e-005

Medium parameters used: $f = 1880$ MHz; $\sigma = 1.455$ S/m; $\epsilon_r = 40.151$; $\rho = 1000$ kg/m³

Phantom section: Flat Section

Measurement Standard: DASYS (IEEE/IEC/ANSI C63.19-2011)

DASY Configuration:

- Probe: EX3DV4 - SN3892; ConvF(8.02, 8.02, 8.02); Calibrated: 11.3.2016;
 - Modulation Compensation:
- Sensor-Surface: 2mm (Mechanical Surface Detection), $z = -9.0$
- Electronics: DAE4 Sn1332; Calibrated: 8.3.2016
- Phantom: ELI V5.0 (20deg probe tilt); Type: QD OVA 002 AA; Serial: 1176
- DASYS2 52.8.8(1258); SEMCAD X 14.6.10(7373)

WCDMA1900 (Band2) - Hotspot check - Head liquid - CH 9400 - Back - Antenna horizontal straight - 5mm/Area Scan (61x111x1); Interpolated grid: $dx=3.000$ mm, $dy=3.000$ mm
Maximum value of SAR (interpolated) = 0.688 W/kg

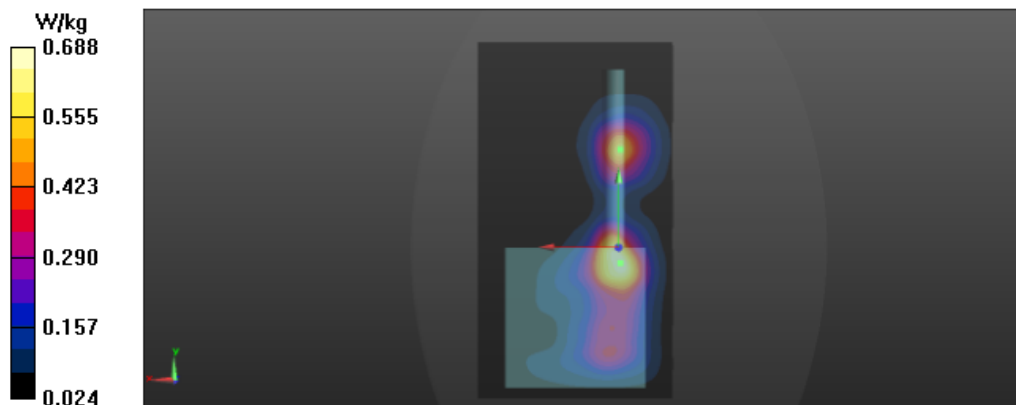

Date/Time: 2.3.2017 19:10:26

Test Laboratory: Verkotan Oy

Antenna horizontal Left

Communication System: UID 0, WCDMA (0); Communication System Band: Band 2; Frequency: 1880 MHz; Communication System PAR: 0 dB; PMF: 1.12202e-005

Medium parameters used: $f = 1880$ MHz; $\sigma = 1.455$ S/m; $\epsilon_r = 40.151$; $\rho = 1000$ kg/m³

Phantom section: Flat Section

Measurement Standard: DASYS (IEEE/IEC/ANSI C63.19-2011)

DASY Configuration:

- Probe: EX3DV4 - SN3892; ConvF(8.02, 8.02, 8.02); Calibrated: 11.3.2016;
 - Modulation Compensation:
- Sensor-Surface: 2mm (Mechanical Surface Detection), $z = -9.0$
- Electronics: DAE4 Sn1332; Calibrated: 8.3.2016
- Phantom: ELI V5.0 (20deg probe tilt); Type: QD OVA 002 AA; Serial: 1176
- DASYS2 52.8.8(1258); SEMCAD X 14.6.10(7373)

WCDMA1900 (Band2) - Hotspot check - Head liquid - CH 9400 - Back - Antenna horizontal Left - 5mm/Area Scan (71x71x1): Interpolated grid: $dx=3.000$ mm, $dy=3.000$ mm

Maximum value of SAR (interpolated) = 0.974 W/kg

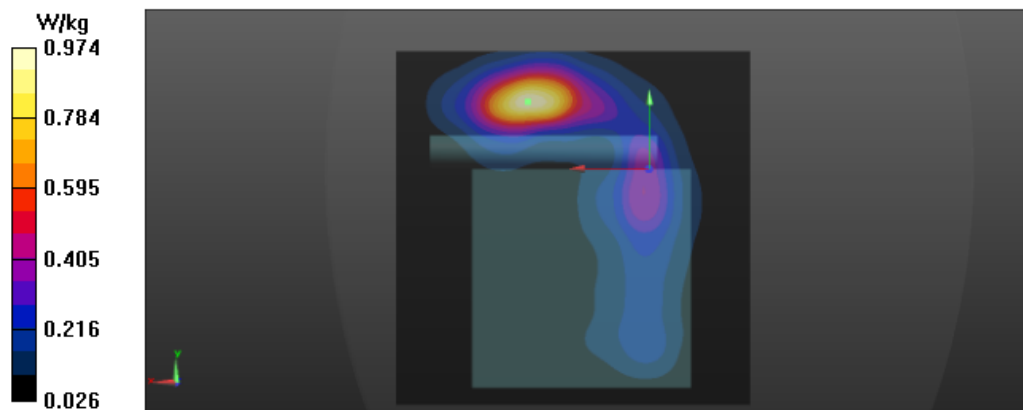

Date/Time: 2.3.2017 19:26:57

Test Laboratory: Verkotan Oy

Antenna vertical

Communication System: UID 0, WCDMA (0); Communication System Band: Band 2; Frequency: 1880 MHz; Communication System PAR: 0 dB; PMF: 1.12202e-005

Medium parameters used: $f = 1880$ MHz; $\sigma = 1.455$ S/m; $\epsilon_r = 40.151$; $\rho = 1000$ kg/m³

Phantom section: Flat Section

Measurement Standard: DASYS (IEEE/IEC/ANSI C63.19-2011)

DASY Configuration:

- Probe: EX3DV4 - SN3892; ConvF(8.02, 8.02, 8.02); Calibrated: 11.3.2016;
 - Modulation Compensation:
- Sensor-Surface: 2mm (Mechanical Surface Detection (Locations From Previous Scan Used)), $z = -9.0$
- Electronics: DAE4 Sn1332; Calibrated: 8.3.2016
- Phantom: ELI V5.0 (20deg probe tilt); Type: QD OVA 002 AA; Serial: 1176
- DASYS2 52.8.8(1258); SEMCAD X 14.6.10(7373)

WCDMA1900 (Band2) Hotspot check - Head liquid - CH 9400 - Back - Antenna vertical - 5mm/Area

Scan (71x71x1): Interpolated grid: $dx=3.000$ mm, $dy=3.000$ mm

Maximum value of SAR (interpolated) = 0.629 W/kg

