

**FCC CFR47 PART 24E, 27  
CERTIFICATION TEST REPORT  
FCC ID: 2ALP3F1**

**Product:** Smart Phone

**Trade Mark:** KODAK

**Model Number:** SmartwayF1

**Family Model:** N/A

**Report No.:** STR200710001006E

**Prepared for**

INDUSTRIA FUEGUINA DE RELOJERIA ELECTRONICA SA  
SARMIENTO 2920, P.O. Box 9420, RIO GRANDE, 9420, Argentina

**Prepared by**

Shenzhen NTEK Testing Technology Co., Ltd.  
1/F, Building E, Fenda Science Park, Sanwei Community, Xixiang Street  
Bao'an District, Shenzhen 518126 P.R. China  
Tel.: +86-755-6115 9388 Fax.: +86-755-6115 6599  
Website: <http://www.ntek.org.cn>

TEST RESULT CERTIFICATION

Applicant's name : INDUSTRIA FUEGUINA DE RELOJERIA ELECTRONICA SA
Address : SARMIENTO 2920, P.O. Box 9420,RIO GRANDE, 9420, Argentina
Manufacturer's Name : LUZHOU ELEPHONE TECH CO.,LTD
Address : NO.8 1st Length, Jiannan Rod ,Jiangyang District ,Luzhou City, Sichuan Province ,CHINA
Product name : Smart Phone
Model and/or type reference : SmartwayF1
Family Model: N/A
Standards : FCC CFR 47 Part Part 24E, Part 27
Test procedure : ANSI C63.26:2015
ANSI/TIA-603-E-2016

This device described above has been tested by NTEK, and the test results show that the equipment under test (EUT) is in compliance with the FCC requirements. And it is applicable only to the tested sample identified in the report.

This report shall not be reproduced except in full, without the written approval of NTEK, this document may be altered or revised by NTEK, personal only, and shall be noted in the revision of the document.

Date of Test
Date (s) of performance of tests : 15 Jul. 2020 ~ 12 Aug, 2020
Date of Issue : 12 Aug, 2020
Test Result : Pass

Testing Engineer : [Signature]
(Cheng Jiawen)
Technical Manager : [Signature]
(Jason Chen)
Authorized Signatory : [Signature]
(Alex Li)

## TABLE OF CONTENTS

<b>1. GENERAL INFORMATION</b> .....	<b>5</b>
1.1 PRODUCT DESCRIPTION .....	5
1.2 RELATED SUBMITTAL(S) / GRANT (S) .....	6
1.3 TEST METHODOLOGY .....	6
1.4 TEST FACILITY .....	6
MEASUREMENT UNCERTAINTY .....	6
1.5 SPECIAL ACCESSORIES.....	6
1.6 WORST-CASE CONFIGURATION AND MODE.....	6
1.6 SUMMARY OF TEST RESULTS .....	7
<b>2. SYSTEM TEST CONFIGURATION</b> .....	<b>9</b>
2.1 EUT CONFIGURATION.....	9
2.2 EUT EXERCISE .....	9
2.3 CONFIGURATION OF EUT SYSTEM.....	9
2.4 TEST SETUP .....	10
<b>3. TEST AND MEASUREMENT EQUIPMENT</b> .....	<b>11</b>
<b>4. OUTPUT POWER</b> .....	<b>13</b>
4.1 OUTPUT POWER MEASUREMENT .....	13
<b>6. BANDEDGE AND EMISSION MASK</b> .....	<b>16</b>
<b>7. OUT OF BAND EMISSIONS</b> .....	<b>17</b>
<b>8. RADIATED MEASUREMENT</b> .....	<b>19</b>
8.1. RADIATED POWER (ERP & EIRP).....	19
8.2 LTE BAND 2.....	20
8.3 LTE BAND 4.....	25
8.4 LTE BAND 7.....	30
<b>9. SPURIOUS RADIATION EMISSION</b> .....	<b>33</b>

9.1 LTE BAND 2.....	35
9.2 LTE BAND 4.....	37
9.3 LTE BAND 7.....	39
10. FREQUENCY STABILITY .....	41
10.1 LTE BAND 2 .....	42
10.2 LTE BAND 4 .....	44
10.3 LTE BAND 7 .....	46
11. PEAK-TO-AVERAGE RATIO.....	48
11.1 Description of the PAR Measurement.....	48
11.2 Measuring Instruments .....	48
11.3 Test Procedures.....	48
11.4 Test Setup.....	48

# 1. GENERAL INFORMATION

## 1.1 PRODUCT DESCRIPTION

A major technical description of EUT is described as following:

Product Designation:	Smart Phone
Trade Mark	KODAK
Model Name	SmartwayF1
Family Model	N/A
Model Difference	N/A
FCC ID:	2ALP3F1
Frequency Bands:	U.S. Bands: <input checked="" type="checkbox"/> LTE FDD Band 2, 4, 7
Frequency Range:	LTE FDD Band 2 Uplink: 1850MHz-1910MHz, Downlink: 1930MHz-1990MHz; LTE FDD Band 4 Uplink: 1710MHz-1755MHz, Downlink: 2110MHz-2155MHz; LTE-FDD Band 7 Uplink: 2500MHz-2570MHz, Downlink: 2620MHz-2690MHz;
Type of Modulation:	QPSK/16QAM
SIM Card	SIM 1 and SIM 2 is a chipset unit and tested as a single chipset. The SIM 1 is chosen for test.
Antenna:	PIFA Antenna
Antenna gain:	Band 2: -0.54dBi, Band 4: -0.6dBi, Band 7: 1.36dBi,
Power Supply:	DC 3.85V/3950mAh from battery or DC 5V from Adapter.
Adapter:	Model: FJ-SW266B50502000A Input: 100-240V~50/60Hz 0.4A Max Output: 5V $\overline{\text{---}}$ 2000mA
Extreme Vol. Limits:	DC 3.4V to DC 4.2V (Nominal DC 3.85V) (Note 1)
HW Version	E6228 V2.0
SW Version	2020.09.02.F1.v1.3
** Note1: The High Voltage 4.2V and Low Voltage 3.4V was declared by manufacturer, The EUT couldn't be operate normally with higher or lower voltage.	

**1.2 RELATED SUBMITTAL(S) / GRANT (S)**

This submittal(s) (test report) is intended for **FCC ID: 2ALP3F1** filing to comply with the FCC Part 24E & 27.

**1.3 TEST METHODOLOGY**

The tests documented in this report were performed in accordance with ANSI/TIA-603-E-2016, FCC CFR 47 Part 2, Part 24, Part 27, ANSI C63.26:2015.

**1.4 TEST FACILITY**

The test site used to collect the radiated data is located at:

ShenZhen NTEK Testing Technology Co., Ltd.

1/F, Building E, Fenda Science Park, Sanwei Community, Xixiang Street, Bao'an District, Shenzhen 518126 P.R.China.

The test site is constructed and calibrated to meet the FCC requirements in documents ANSI C63.26:2015& ANSI C63.4: 2014.

FCC Registration No.:463705

IC Registration No.:9270A-1,

CNAS Registration No.:L5516

**MEASUREMENT UNCERTAINTY**

The reported uncertainty of measurement, where expended uncertainty U is based on a standard uncertainty multiplied by a coverage factor of k=2, providing a level of confidence of approximately 95 %.

No.	Item	Uncertainty
1	Measuring Uncertainty for a Level of Confidence of 95% (U = 2Uc(y))	2.5dB

**1.5 SPECIAL ACCESSORIES**

The battery and the charger, earphone supplied by the applicant were used as accessories and being tested with EUT intended for FCC grant together.

**1.6 WORST-CASE CONFIGURATION AND MODE**

The worst-case scenario for all measurements is based on the investigation results.

The device has LTE Bands of: Band 2, Band 4, Band 7.

The RB Size was selected to measure for peak or average ERP and EIRP, which was based on the conducted power verification baseline data.

For the fundamental investigation of radiated emissions, the EUT is investigated for vertical and horizontal antenna orientations and X Y and Z orientations of the EUT alone. After the investigations the worst case was determined to be at X orientation for all LTE bands.

**1.6 SUMMARY OF TEST RESULTS**

FCC Part24, Subpart E, FCC Part27, Subpart L, KDB 971168 D01 Power Meas License Digital Systems v03			
FCC Rule	Test Item	Verdict	Remark
2.1046	Conducted Output Power	PASS	
24.232(d) 27.50(d)(5) KDB 971168 D01 Clause 5.7	Peak-to-Average Ratio	PASS	
2.1049 24.238(b) KDB 971168 D01 Clause 4.2	Occupied Bandwidth	PASS	
2.1051 24.238(a) 27.53(c), (g), (h) KDB 971168 D01 Clause 6	Band Edge	PASS	
27.50(b)(10), (c)(10) KDB 971168 D01 Clause 5.6	Effective Radiated Power	PASS	
24.232(c) 27.50(h)(2), (d)(4) KDB 971168 D01 Clause 5.6	Equivalent Isotropic Radiated Power	PASS	
2.1053 24.238(a) 27.53(c)(g)(h)(m) KDB 971168 D01 Clause 7	Field Strength of Spurious Radiation	PASS	
2.1055 24.235 27.54 KDB 971168 D01 Clause 9	Frequency Stability for Temperature & Voltage	PASS	
2.1051 24.238(a) 27.53(c)(g)(h)(m) KDB 971168 D01 Clause 6	Conducted Emission	PASS	

Remark:

1. "N/A" denotes test is not applicable in this Test Report.
2. All test items were verified and recorded according to the standards and without any deviation during the test.
3. No modifications are made to the EUT during all test items.



## 2. SYSTEM TEST CONFIGURATION

### 2.1 EUT CONFIGURATION

The EUT configuration for testing is installed on RF field strength measurement to meet the Commission's requirement and operating in a manner which intends to maximize its emission characteristics in a continuous normal application.

### 2.2 EUT EXERCISE

The Transmitter was operated in the maximum output power mode through Communication Tester. The TX frequency was fixed which was for the purpose of the measurements.

### 2.3 CONFIGURATION OF EUT SYSTEM

Table 2-1 Equipment Used in EUT System

Item	Equipment	Model No.	ID or Specification	Note
1	Smart Phone	SmartwayF1	FCC ID: 2ALP3F1	EUT

*Note: All the accessories have been used during the test.  
the following "EUT" in setup diagram means EUT system.*

**2.4 TEST SETUP**

For Radiated Test Cases

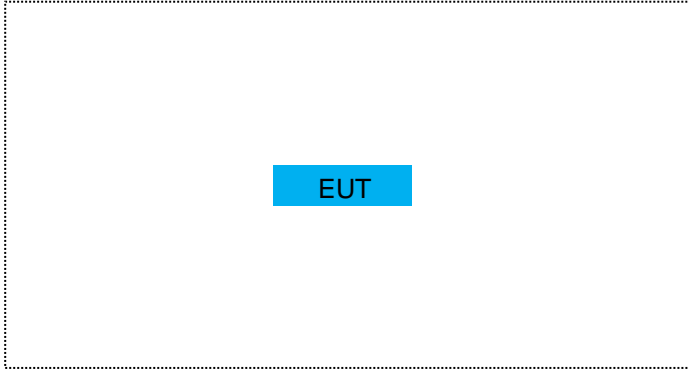

For Conducted Output Power

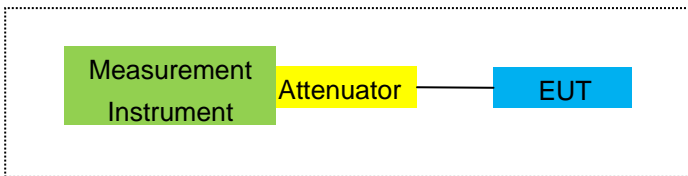

For Peak-to Average Ratio, Occupied Bandwidth, Conducted Band edge and Conducted Spurious Emission

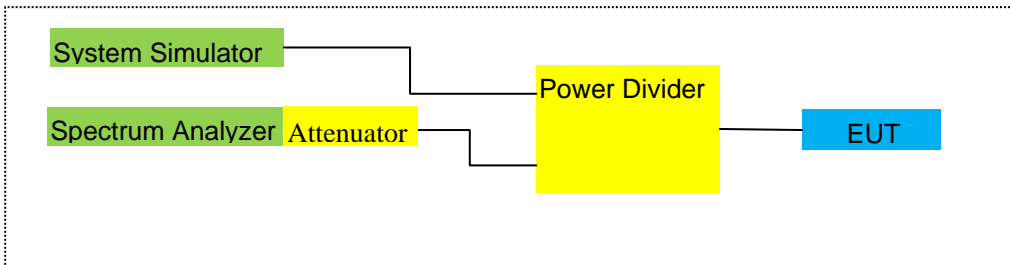

For Frequency Stability

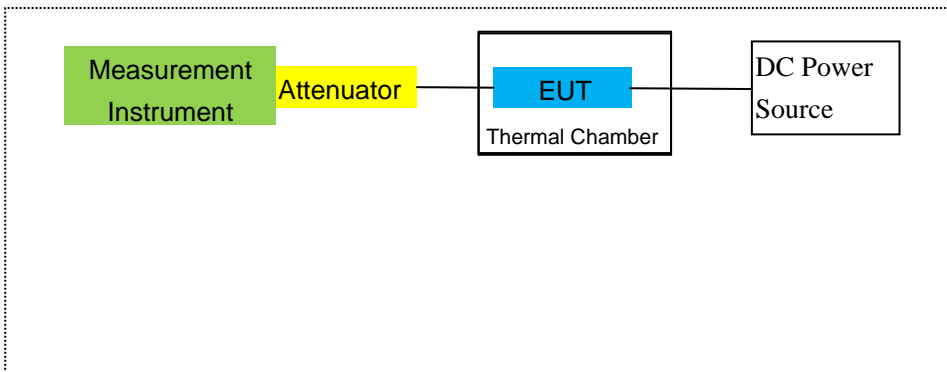

Note: EUT built-in battery-powered, the battery is fully-charged.

### 3. TEST AND MEASUREMENT EQUIPMENT

The following test and measurement equipment was utilized for the tests documented in this report:

Item	Kind of Equipment	Manufacturer	Type No.	Serial No.	Last calibration	Calibrated until	Calibration period
1	MXA Signal Analyzer	Agilent	N9020A	MY49100060	2020.05.11	2021.05.10	1 year
2	Test Receiver	R&S	ESPI	101318	2020.05.11	2021.05.10	1 year
3	Bilog Antenna	TESEQ	CBL6111D	31216	2020.04.11	2021.04.10	1 year
4	50Ω Coaxial Switch	Anritsu	MP59B	6200983705	2020.05.11	2021.05.10	1 year
5	Horn Antenna	EM	EM-AH-10180	2011071402	2020.04.11	2021.04.10	1 year
6	Horn Ant	Schwarzbeck	BBHA 9170	9170-181	2019.12.10	2020.12.09	1 year
7	Amplifier	EM	EM-30180	060538	2020.05.11	2021.05.10	1 year
8	Loop Antenna	ARA	PLA-1030/B	1029	2020.05.11	2021.05.10	1 year
9	Power Meter	R&S	NRVS	100696	2020.05.11	2021.05.10	1 year
10	Power Sensor	R&S	URV5-Z4	0395.1619.05	2020.05.11	2021.05.10	1 year
11	Test Cable	N/A	R-01	N/A	2019.08.06	2022.08.05	3 year
12	Test Cable	N/A	R-02	N/A	2020.05.11	2021.05.10	1 year
13	Test Cable	N/A	R-03	N/A	2019.06.28	2022.06.27	3 year
14	Test Receiver	R&S	ESCI	101160	2020.05.11	2021.05.10	1 year
15	LISN	R&S	ENV216	101313	2020.05.11	2021.05.10	1 year
16	LISN	EMCO	3816/2	00042990	2020.05.11	2021.05.10	1 year
17	50Ω Coaxial Switch	Anritsu	MP59B	6200264417	2020.05.11	2021.05.10	1 year
18	Passive Voltage Probe	R&S	ESH2-Z3	100196	2020.04.11	2021.04.10	1 year
19	Test Cable	N/A	C01	N/A	2020.05.11	2023.05.10	3 year
20	Test Cable	N/A	C02	N/A	2020.05.11	2023.05.10	3 year
21	Test Cable	N/A	C03	N/A	2020.05.11	2021.05.10	1 year
22	Attenuator	MCE	24-10-34	BN9258	2020.05.11	2021.05.10	1 year
23	Spectrum Analyzer	agilent	e4440a	us44300399	2020.05.11	2021.05.10	1 year
24	test receiver	R&S	ESCI	a0304218	2020.05.11	2021.05.10	1 year
25	Communication Tester	R&S	CMU200	A0304247	2020.05.11	2021.05.10	1 year
26	Thermal Chamber	Ten Billion	TTC-B3C	TBN-960502	2020.05.11	2021.05.10	1 year

27	DC Power Source	N/A	PS-6005D	2017040292 3	2018.06.06	2021.06.05	3 year
28	PSG Analog Signal Generator	Agilent	E8257D	MY51110112	2020.05.11	2021.05.10	1 year
29	Communication Tester	R&S	CMW500	148500	2020.05.11	2021.05.10	1 year

Note: Each piece of equipment is scheduled for calibration once a year except the Test Cable& DC Power Source which is scheduled for calibration every 3 years.

## 4. OUTPUT POWER

### 4.1 OUTPUT POWER MEASUREMENT

#### LTE Measurement Procedure:

All LTE bands conducted power peak and average are obtained from the CMW500 telecommunication test set. The following tests were conducted according to the test requirements outlined in section 6.2 of the 3GPP TS36.101 specification.

UE Power Class: 3 (23 +/- 2dBm). The allowed Maximum Power Reduction (MPR) for the maximum output power due to higher order modulation and transmit bandwidth configuration (resource blocks) is specified in Table 6.2.3-1 of the 3GPP TS36.101.

**Table 6.2.3-1: Maximum Power Reduction (MPR) for Power Class 3**

Modulation	Channel bandwidth / Transmission bandwidth (RB)						MPR (dB)
	1.4 MHz	3.0 MHz	5 MHz	10 MHz	15 MHz	20 MHz	
QPSK	> 5	> 4	> 8	> 12	> 16	> 18	≤ 1
16 QAM	≤ 5	≤ 4	≤ 8	≤ 12	≤ 16	≤ 18	≤ 1
16 QAM	> 5	> 4	> 8	> 12	> 16	> 18	≤ 2

The allowed A-MPR values specified below in Table 6.2.4.-1 of 3GPP TS36.101 are in addition to the allowed MPR requirements. All the measurements below were performed with A-MPR disabled, by using Network Signaling Value of "NS\_01".3

**Table 6.2.4-1: Additional Maximum Power Reduction (A-MPR)**

Network Signalling value	Requirements (sub-clause)	E-UTRA Band	Channel bandwidth (MHz)	Resources Blocks ( $N_{RB}$ )	A-MPR (dB)
NS_01	6.6.2.1.1	Table 5.5-1	1.4, 3, 5, 10, 15, 20	Table 5.6-1	NA
NS_03	6.6.2.2.1	2, 4, 10, 23, 25, 35, 36	3	>5	$\leq 1$
			5	>6	$\leq 1$
			10	>6	$\leq 1$
			15	>8	$\leq 1$
			20	>10	$\leq 1$
NS_04	6.6.2.2.2	41	5	>6	$\leq 1$
			10, 15, 20	See Table 6.2.4-4	
NS_05	6.6.3.3.1	1	10, 15, 20	$\geq 50$	$\leq 1$
NS_06	6.6.2.2.3	12, 13, 14, 17	1.4, 3, 5, 10	Table 5.6-1	n/a
NS_07	6.6.2.2.3	13	10	Table 6.2.4-2	Table 6.2.4-2
	6.6.3.3.2				
NS_08	6.6.3.3.3	19	10, 15	> 44	$\leq 3$
NS_09	6.6.3.3.4	21	10, 15	> 40	$\leq 1$
				> 55	$\leq 2$
NS_10		20	15, 20	Table 6.2.4-3	Table 6.2.4-3
NS_11	6.6.2.2.1	23 <sup>1</sup>	1.4, 3, 5, 10	Table 6.2.4-5	Table 6.2.4-5
..					
NS_32	-	-	-	-	-

Note 1: Applies to the lower block of Band 23, i.e. a carrier placed in the 2000-2010 MHz region.

Test data reference attachment.

## 5. OCCUPIED BANDWIDTH

### RULE PART(S)

FCC: §2.1049

### LIMITS

For reporting purposes only

### TEST PROCEDURE

The transmitter output was connected to a calibrated coaxial cable and coupler, the other end of which was connected to a spectrum analyzer. The occupied bandwidth was measured with the spectrum analyzer at the low, middle and high channel in each band. The -26dB bandwidth was also measured and recorded.

### MODES TESTED

- LTE Band 2
- LTE Band 4
- LTE Band 7

### RESULTS

**PASS**

Test data reference attachment.

## 6. BANDEDGE AND EMISSION MASK

### RULE PART(S)

FCC: §2.1051, §24.238(a), §27.53(c)(g)(h)(m)

FCC: §2.1046, §24.232

### LIMITS

The minimum permissible attenuation level of any spurious emission is  $43 + \log_{10}(P[\text{Watts}])$ , where P is the transmitter power in Watts.

The minimum permissible attenuation level for Band 7 is as following.

Per 27.53(g) for operations in the 698-746 MHz band, in the 100 kHz bands immediately outside and adjacent to the frequency block a resolution bandwidth of at least 30 kHz may be employed to demonstrate compliance with the out-of-band emissions limit.

Per 27.53(c.5) for operations in the 776-788 MHz band, in the 100 kHz bands immediately outside and adjacent to the frequency block a resolution bandwidth of at least 30 kHz may be employed to demonstrate compliance with the out-of-band emissions limit.

For all plots showing emissions in the 763 – 775MHz and 793 – 805MHz band, the FCC limit per 27.53(c.4) is  $65 + 10\log_{10}(P) = -35\text{dBm}$  in a 6.25kHz bandwidth.

Per 27.53(m) for operations in the BRS/EBS bands, the attenuation factor shall be not less than  $40 + 10 \log (P)$  dB on all frequencies between the channel edge and 5 megahertz from the channel edge,  $43 + 10 \log (P)$  dB on all frequencies between 5 megahertz and X megahertz from the channel edge, and  $55 + 10 \log (P)$  dB on all frequencies more than X megahertz from the channel edge, where X is the greater of 6 megahertz or the actual emission bandwidth.

### TEST PROCEDURE

The transmitter output was connected to a CMW500 Test Set and configured to operate at maximum power. The band edge emissions were measured at the required operating frequencies in each band on the Spectrum Analyzer.

For each band edge measurement:

Set the spectrum analyzer span to include the block edge frequency

Set a marker to point the corresponding band edge frequency in each test case.

Set display line

Set resolution bandwidth to at least 1% of emission bandwidth.

### MODES TESTED

- LTE Band 2/4/7

### RESULTS

Test data reference attachment.

Note: Both QPSK and 16QAM has been tested, the LTE Band 2/4 worst case is 16QAM mode, the report just reported the worst case.



## 7. OUT OF BAND EMISSIONS

### RULE PART(S)

FCC: §2.1051, §24.238(a), §27.53(c)(g)(h)(m)

### LIMITS

The minimum permissible attenuation level of any spurious emission is  $43 + \log_{10}(P[\text{Watts}])$ , where P is the transmitter power in Watts.

The minimum permissible attenuation level for Band 7 is as following.

Per 27.53(g) for operations in the 698-746 MHz band, in the 100 kHz bands immediately outside and adjacent to the frequency block a resolution bandwidth of at least 30 kHz may be employed to demonstrate compliance with the out-of-band emissions limit.

Per 27.53(c.5) for operations in the 776-788 MHz band, in the 100 kHz bands immediately outside and adjacent to the frequency block a resolution bandwidth of at least 30 kHz may be employed to demonstrate compliance with the out-of-band emissions limit.

For all plots showing emissions in the 763 – 775MHz and 793 – 805MHz band, the FCC limit per 27.53(c.4) is  $65 + 10\log_{10}(P) = -35\text{dBm}$  in a 6.25kHz bandwidth.

Per 27.53(m) for operations in the BRS/EBS bands, the attenuation factor shall be not less than  $40 + 10 \log (P)$  dB on all frequencies between the channel edge and 5 megahertz from the channel edge,  $43 + 10 \log (P)$  dB on all frequencies between 5 megahertz and X megahertz from the channel edge, and  $55 + 10 \log (P)$  dB on all frequencies more than X megahertz from the channel edge, where X is the greater of 6 megahertz or the actual emission bandwidth.

### TEST PROCEDURE

The RF output of the transmitter was connected to a spectrum analyzer through a calibrated coaxial cable. Sufficient scans were taken to show the out-of-band Emissions, if any, up to 10th harmonic. Multiple sweeps were recorded in maximum hold mode using a peak detector to ensure that the worst-case emissions were caught.

For each out of band emissions measurement:

- Set display line
- Set RBW & VBW to 100 kHz for the measurement below 1 GHz, and 1 MHz for the measurement above 1 GHz.

### MODES TESTED

- LTE Band2
- LTE Band 4
- LTE Band 7

### 7.1 MEASUREMENT METHOD

The test set up and general procedure is similar to conducted peak output power test. Only different for setting the measurement configuration of the measuring instrument of Spectrum Analyzer.

Test data reference attachment.

Note: Both QPSK and 16QAM has been tested, the LTE Band 2/4 worst case is 16QAM mode, the report just reported the worst case.

## 8. RADIATED MEASUREMENT

### 8.1. RADIATED POWER (ERP & EIRP)

#### RULE PART(S)

FCC: §2.1046, §24.232(c) and §27.50 (h)(2), (b)(10), (c)(10), (d)(4)

#### LIMITS:

24.232 (c) Mobile and portable stations are limited to 2 watts EIRP.

27.50 (c) (10) the following power and antenna height requirements apply to stations transmitting in the 698–746 MHz band, the portable stations (hand-held devices) are limited to 3 watts ERP.

27.50 (b)(10) Portable stations (hand-held devices) transmitting in the 746–757 MHz, 758–763 MHz, 776–793 MHz, and 805–806 MHz bands are limited to 3 watts ERP.

27.50 (d)(4) The following power and antenna height requirements apply to stations transmitting in the 1710–1755 MHz and 2110–2155 MHz bands: Fixed, mobile, and portable (hand-held) stations operating in the 1710–1755 MHz band are limited to 1 watt EIRP.

27.50 (h)(2) Mobile and other user stations in the 2500–2570 MHz and 2620–2690 MHz bands. Mobile stations are limited to 2.0 watts EIRP. All user stations are limited to 2.0 watts transmitter output power.

#### TEST PROCEDURE

ANSI/TIA-603-E Clause 2.2.17

KDB 971168 v02r01 RF power output using broadband peak and average power meter method.

KDB 971168 D01 Power Meas License Digital Systems v02r01, “Measurement Guidance for Certification of Licensed Digital Transmitters”

#### MODES TESTED

- LTE Band2
- LTE Band 4
- LTE Band 7

#### RESULTS

Pass

8.2 LTE BAND 2

Radiated Power (EIRP) for Band 2									
Mode	RB Size / RB Position	Frequency	Result						Conclusion
			SG Level (dBm)	Cable Loss (dBm)	Antenna Gain (dB)	Max. EIRP Average (dBm)	Max. EIRP Average (mW)	Polarization Of Max. ERP	
1.4MHz Band QPSK	1/#Mid	1850.7	-1.25	3.76	28.24	23.23	210.378	Horizontal	Pass
		1880	-0.86	3.91	28.22	23.45	221.309	Horizontal	Pass
		1909.3	-1.00	3.93	28.20	23.27	212.324	Horizontal	Pass
3.0MHz Band QPSK	1/#Mid	1851.5	-1.28	3.77	28.23	23.18	207.970	Horizontal	Pass
		1880	-0.78	3.91	28.24	23.55	226.464	Horizontal	Pass
		1908.5	-1.11	3.94	28.25	23.20	208.930	Horizontal	Pass
5.0MHz Band QPSK	1/#Mid	1852.5	-1.53	3.77	28.31	23.01	199.986	Horizontal	Pass
		1880	-0.78	3.91	28.22	23.53	225.424	Horizontal	Pass
		1907.5	-1.25	3.94	28.20	23.01	199.986	Horizontal	Pass
10.0MHz Band QPSK	1/#Mid	1855	-1.24	3.79	28.33	23.30	213.796	Horizontal	Pass
		1880	-1.40	3.95	28.22	22.87	193.642	Horizontal	Pass
		1905	-1.03	3.97	28.19	23.19	208.449	Horizontal	Pass
15.0MHz Band QPSK	1/#Mid	1857.5	-1.28	3.79	28.34	23.27	212.324	Horizontal	Pass
		1880	-0.88	3.95	28.22	23.39	218.273	Horizontal	Pass
		1902.5	-1.06	3.97	28.18	23.15	206.538	Horizontal	Pass
20.0MHz	1/#Mid	1860	-0.80	3.81	28.35	23.74	236.59	Horizontal	Pass

z Band QPSK							2		
		1880	-0.96	3.96	28.22	23.30	213.79 6	Horizontal	Pass
		1900	-1.13	4.00	28.16	23.03	200.90 9	Horizontal	Pass
1.4MHz Band QPSK	1/#Mid	1850.7	-1.15	3.76	28.24	23.33	215.27 8	Vertical	Pass
		1880	-0.83	3.91	28.22	23.48	222.84 4	Vertical	Pass
		1909.3	-0.95	3.93	28.20	23.32	214.78 3	Vertical	Pass
3.0MHz Band QPSK	1/#Mid	1851.5	-1.12	3.77	28.23	23.34	215.77 4	Vertical	Pass
		1880	-0.67	3.91	28.24	23.66	232.27 4	Vertical	Pass
		1908.5	-1.05	3.94	28.25	23.26	211.83 6	Vertical	Pass
5.0MHz Band QPSK	1/#Mid	1852.5	-1.26	3.77	28.31	23.28	212.81 4	Vertical	Pass
		1880	-0.67	3.91	28.22	23.64	231.20 6	Vertical	Pass
		1907.5	-1.05	3.94	28.20	23.21	209.41 1	Vertical	Pass
10.0MH z Band QPSK	1/#Mid	1855	-1.21	3.79	28.33	23.33	215.27 8	Vertical	Pass
		1880	-0.85	3.95	28.22	23.42	219.78 6	Vertical	Pass
		1905	-0.87	3.97	28.19	23.35	216.27 2	Vertical	Pass
15.0MH z Band QPSK	1/#Mid	1857.5	-1.33	3.79	28.34	23.22	209.89 4	Vertical	Pass
		1880	-0.74	3.95	28.22	23.53	225.42 4	Vertical	Pass
		1902.5	-1.07	3.97	28.18	23.14	206.06 3	Vertical	Pass
20.0MH z Band QPSK	1/#Mid	1860	-1.58	3.81	28.35	22.96	197.69 7	Vertical	Pass
		1880	-0.97	3.96	28.22	23.29	213.30 4	Vertical	Pass
		1900	-1.19	4.00	28.16	22.97	198.15	Vertical	Pass

							3		
--	--	--	--	--	--	--	---	--	--

Note:

SG Level= Signal generator output

Max. EIRP Average (dBm)= Antenna Gain(dB)+ SG Level (dBm)- Cable Loss(dBm)

Radiated Power (EIRP) for Band 2									
Mode	RB Size / RB Position	Frequency	Result					Polarization Of Max. ERP	Conclusion
			SG Level (dBm)	Cable Loss (dBm)	Antenna Gain (dB)	Max. EIRP Average (dBm)	Max. EIRP Average (mW)		
1.4MHz Band 16 QAM	1/#Mid	1850.7	-2.19	3.76	28.24	22.29	169.434	Horizontal	Pass
		1880	-1.84	3.91	28.22	22.47	176.604	Horizontal	Pass
		1909.3	-1.93	3.93	28.20	22.34	171.396	Horizontal	Pass
3.0MHz Band 16 QAM	1/#Mid	1851.5	-1.86	3.77	28.23	22.60	181.970	Horizontal	Pass
		1880	-1.44	3.91	28.24	22.89	194.536	Horizontal	Pass
		1908.5	-1.69	3.94	28.25	22.62	182.810	Horizontal	Pass
5.0MHz Band 16 QAM	1/#Mid	1852.5	-1.49	3.77	28.31	23.05	201.837	Horizontal	Pass
		1880	-0.79	3.91	28.22	23.52	224.905	Horizontal	Pass
		1907.5	-1.18	3.94	28.20	23.08	203.236	Horizontal	Pass
10.0MHz Band 16 QAM	1/#Mid	1855	-2.13	3.79	28.33	22.41	174.181	Horizontal	Pass
		1880	-1.81	3.95	28.22	22.46	176.198	Horizontal	Pass
		1905	-1.84	3.97	28.19	22.38	172.982	Horizontal	Pass
15.0MHz Band 16 QAM	1/#Mid	1857.5	-2.19	3.79	28.34	22.36	172.187	Horizontal	Pass
		1880	-1.58	3.95	28.22	22.69	185.780	Horizontal	Pass
		1902.5	-1.85	3.97	28.18	22.36	172.187	Horizontal	Pass
20.0MHz Band 16 QAM	1/#Mid	1860	-2.18	3.81	28.35	22.36	172.187	Horizontal	Pass
		1880	-1.61	3.96	28.22	22.65	184.077	Horizontal	Pass
		1900	-1.79	4.00	28.16	22.37	172.584	Horizontal	Pass
1.4MHz Band 16 QAM	1/#Mid	1850.7	-1.89	3.76	28.24	22.59	181.552	Vertical	Pass
		1880	-1.55	3.91	28.22	22.76	188.799	Vertical	Pass
		1909.3	-1.76	3.93	28.20	22.51	178.238	Vertical	Pass
3.0MHz Band 16 QAM	1/#Mid	1851.5	-1.88	3.77	28.23	22.58	181.134	Vertical	Pass
		1880	-1.44	3.91	28.24	22.89	194.536	Vertical	Pass
		1908.5	-1.81	3.94	28.25	22.50	177.828	Vertical	Pass
5.0MHz Band 16 QAM	1/#Mid	1852.5	-1.70	3.77	28.31	22.84	192.309	Vertical	Pass
		1880	-1.13	3.91	28.22	23.18	207.970	Vertical	Pass
		1907.5	-1.13	3.94	28.20	23.13	205.589	Vertical	Pass
10.0MHz Band 16 QAM	1/#Mid	1855	-2.35	3.79	28.33	22.19	165.577	Vertical	Pass
		1880	-1.88	3.95	28.22	22.39	173.380	Vertical	Pass
		1905	-2.02	3.97	28.19	22.20	165.959	Vertical	Pass
15.0MHz Band 16	1/#Mid	1857.5	-2.20	3.79	28.34	22.35	171.791	Vertical	Pass
		1880	-1.57	3.95	28.22	22.70	186.209	Vertical	Pass

QAM		1902.5	-1.50	3.97	28.18	22.71	186.638	Vertical	Pass
20.0MHz	1/#Mid	1860	-2.20	3.81	28.35	22.34	171.396	Vertical	Pass
Band 16		1880	-0.59	3.96	28.22	23.67	232.809	Vertical	Pass
QAM		1900	-1.88	4.00	28.16	22.28	169.044	Vertical	Pass

Note:

SG Level= Signal generator output

Max. EIRP Average (dBm)= Antenna Gain(dB)+ SG Level (dBm)- Cable Loss(dBm)



8.3 LTE BAND 4

Radiated Power (EIRP) for Band 4									
Mode	RB Size / RB Position	Frequency	Result						Conclusion
			SG Level (dBm)	Cable Loss (dBm)	Antenna Gain (dB)	Max. EIRP Average (dBm)	Max. EIRP Average (mW)	Polarization Of Max. ERP	
1.4MHz Band QPSK	1/#Mid	1710.7	-1.34	3.12	27.58	23.12	205.116	Horizontal	Pass
		1732.5	-1.12	3.27	27.61	23.22	209.894	Horizontal	Pass
		1754.3	-1.26	3.29	27.63	23.08	203.236	Horizontal	Pass
3.0MHz Band QPSK	1/#Mid	1711.5	-1.42	3.13	27.61	23.06	202.302	Horizontal	Pass
		1732.5	-1.10	3.27	27.61	23.24	210.863	Horizontal	Pass
		1753.5	-1.35	3.30	27.62	22.97	198.153	Horizontal	Pass
5.0MHz Band QPSK	1/#Mid	1712.5	-1.54	3.13	27.63	22.96	197.697	Horizontal	Pass
		1732.5	-0.96	3.27	27.61	23.38	217.771	Horizontal	Pass
		1752.5	-1.36	3.30	27.60	22.94	196.789	Horizontal	Pass
10.0MHz Band QPSK	1/#Mid	1715	-1.50	3.15	27.64	22.99	199.067	Horizontal	Pass
		1732.5	-1.24	3.31	27.61	23.06	202.302	Horizontal	Pass
		1750	-1.36	3.33	27.59	22.90	194.984	Horizontal	Pass
15.0MHz Band QPSK	1/#Mid	1717.5	-1.53	3.15	27.65	22.97	198.153	Horizontal	Pass
		1732.5	-1.33	3.31	27.61	22.97	198.153	Horizontal	Pass
		1747.5	-1.38	3.33	27.57	22.86	193.197	Horizontal	Pass

20.0MHz z Band QPSK	1/#Mid	1720	-1.72	3.17	27.66	22.77	189.23 4	Horizontal	Pass
		1732.5	-0.75	3.32	27.61	23.54	225.94 4	Horizontal	Pass
		1745	-1.57	3.36	27.56	22.63	183.23 1	Horizontal	Pass
1.4MHz Band QPSK	1/#Mid	1710.7	-1.33	3.12	27.58	23.13	205.58 9	Vertical	Pass
		1732.5	-1.04	3.27	27.61	23.30	213.79 6	Vertical	Pass
		1754.3	-1.21	3.29	27.63	23.13	205.58 9	Vertical	Pass
3.0MHz Band QPSK	1/#Mid	1711.5	-1.50	3.13	27.61	22.98	198.60 9	Vertical	Pass
		1732.5	-1.13	3.27	27.61	23.21	209.41 1	Vertical	Pass
		1753.5	-1.42	3.30	27.62	22.90	194.98 4	Vertical	Pass
5.0MHz Band QPSK	1/#Mid	1712.5	-1.63	3.13	27.63	22.87	193.64 2	Vertical	Pass
		1732.5	-1.06	3.27	27.61	23.28	212.81 4	Vertical	Pass
		1752.5	-1.50	3.30	27.60	22.80	190.54 6	Vertical	Pass
10.0MHz z Band QPSK	1/#Mid	1715	-1.75	3.15	27.64	22.74	187.93 2	Vertical	Pass
		1732.5	-1.47	3.31	27.61	22.83	191.86 7	Vertical	Pass
		1750	-1.53	3.33	27.59	22.73	187.49 9	Vertical	Pass
15.0MHz z Band QPSK	1/#Mid	1717.5	-2.53	3.15	27.65	21.97	157.39 8	Vertical	Pass
		1732.5	-2.16	3.31	27.61	22.14	163.68 2	Vertical	Pass
		1747.5	-2.42	3.33	27.57	21.82	152.05 5	Vertical	Pass
20.0MHz z Band QPSK	1/#Mid	1720	-1.75	3.17	27.66	22.74	187.93 2	Vertical	Pass
		1732.5	-1.28	3.32	27.61	23.01	199.98 6	Vertical	Pass

		1745	-1.62	3.36	27.56	22.58	181.13 4	Vertical	Pass
--	--	------	-------	------	-------	-------	-------------	----------	------

Note:

SG Level= Signal generator output

Max. EIRP Average (dBm)= Antenna Gain(dB)+ SG Level (dBm)- Cable Loss(dBm)

Radiated Power (EIRP) for Band 4									
Mode	RB Size / RB Position	Frequency	Result						Conclusion
			SG Level (dBm)	Cable Loss (dBm)	Antenna Gain (dB)	Max. EIRP Average (dBm)	Max. EIRP Average (mW)	Polarization Of Max. ERP	
1.4MHz Band 16 QAM	1/#Mid	1710.7	-2.60	3.12	27.58	21.86	153.462	Horizontal	Pass
		1732.5	-2.33	3.27	27.61	22.01	158.855	Horizontal	Pass
		1754.3	-2.49	3.29	27.63	21.85	153.109	Horizontal	Pass
3.0MHz Band 16 QAM	1/#Mid	1711.5	-2.12	3.13	27.61	22.36	172.187	Horizontal	Pass
		1732.5	-1.76	3.27	27.61	22.58	181.134	Horizontal	Pass
		1753.5	-2.11	3.30	27.62	22.21	166.341	Horizontal	Pass
5.0MHz Band 16 QAM	1/#Mid	1712.5	-2.15	3.13	27.63	22.35	171.791	Horizontal	Pass
		1732.5	-1.58	3.27	27.61	22.76	188.799	Horizontal	Pass
		1752.5	-2.08	3.30	27.60	22.22	166.725	Horizontal	Pass
10.0MHz Band 16 QAM	1/#Mid	1715	-2.22	3.15	27.64	22.27	168.655	Horizontal	Pass
		1732.5	-2.01	3.31	27.61	22.29	169.434	Horizontal	Pass
		1750	-2.16	3.33	27.59	22.10	162.181	Horizontal	Pass
15.0MHz Band 16 QAM	1/#Mid	1717.5	-2.67	3.15	27.65	21.83	152.405	Horizontal	Pass
		1732.5	-2.39	3.31	27.61	21.91	155.239	Horizontal	Pass
		1747.5	-2.37	3.33	27.57	21.87	153.815	Horizontal	Pass
20.0MHz Band 16 QAM	1/#Mid	1720	-2.48	3.17	27.66	22.01	158.855	Horizontal	Pass
		1732.5	-2.26	3.32	27.61	22.03	159.588	Horizontal	Pass
		1745	-2.44	3.36	27.56	21.76	149.968	Horizontal	Pass
1.4MHz Band 16 QAM	1/#Mid	1710.7	-2.59	3.12	27.58	21.87	153.815	Vertical	Pass
		1732.5	-2.35	3.27	27.61	21.99	158.125	Vertical	Pass
		1754.3	-2.49	3.29	27.63	21.85	153.109	Vertical	Pass
3.0MHz Band 16 QAM	1/#Mid	1711.5	-2.62	3.13	27.61	21.86	153.462	Vertical	Pass
		1732.5	-2.16	3.27	27.61	22.18	165.196	Vertical	Pass
		1753.5	-2.41	3.30	27.62	21.91	155.239	Vertical	Pass
5.0MHz Band 16 QAM	1/#Mid	1712.5	-2.57	3.13	27.63	21.93	155.955	Vertical	Pass
		1732.5	-2.07	3.27	27.61	22.27	168.655	Vertical	Pass
		1752.5	-2.32	3.30	27.60	21.98	157.761	Vertical	Pass
10.0MHz Band 16 QAM	1/#Mid	1715	-1.60	3.15	27.64	22.89	194.536	Vertical	Pass
		1732.5	-1.12	3.31	27.61	23.18	207.970	Vertical	Pass
		1750	-1.44	3.33	27.59	22.82	191.426	Vertical	Pass
15.0MHz Band 16	1/#Mid	1717.5	-1.65	3.15	27.65	22.85	192.752	Vertical	Pass
		1732.5	-1.20	3.31	27.61	23.10	204.174	Vertical	Pass

QAM		1747.5	-1.55	3.33	27.57	22.69	185.780	Vertical	Pass
20.0MHz	1/#Mid	1720	-2.83	3.17	27.66	21.66	146.555	Vertical	Pass
Band 16		1732.5	-0.93	3.32	27.61	23.36	216.770	Vertical	Pass
QAM		1745	-2.37	3.36	27.56	21.83	152.405	Vertical	Pass

Note:

SG Level= Signal generator output

Max. EIRP Average (dBm)= Antenna Gain(dB)+ SG Level (dBm)- Cable Loss(dBm)

8.4 LTE BAND 7

Radiated Power (EIRP) for Band 7									
Mode	RB Size / RB Position	Frequency	Result						Conclusion
			SG Level (dBm)	Cable Loss (dBm)	Antenna Gain (dB)	Max. EIRP Average (dBm)	Max. EIRP Average (mW)	Polarization Of Max. ERP	
5.0MHz Band QPSK	1/#Mid	2502.5	2.78	4.54	27.75	25.99	397.192	Horizontal	Pass
		2535	3.42	4.69	27.72	26.45	441.570	Horizontal	Pass
		2567.5	2.87	4.71	27.71	25.87	386.367	Horizontal	Pass
10.0MHz Band QPSK	1/#Mid	2505	2.73	4.55	27.76	25.94	392.645	Horizontal	Pass
		2535	2.88	4.69	27.72	25.91	389.942	Horizontal	Pass
		2565	2.81	4.72	27.70	25.79	379.315	Horizontal	Pass
15.0MHz Band QPSK	1/#Mid	2507.5	2.26	4.55	27.77	25.48	353.183	Horizontal	Pass
		2535	2.56	4.69	27.72	25.59	362.243	Horizontal	Pass
		2562.5	2.53	4.72	27.69	25.50	354.813	Horizontal	Pass
20.0MHz Band QPSK	1/#Mid	2510	2.67	4.57	27.78	25.88	387.258	Horizontal	Pass
		2535	3.64	4.73	27.72	26.63	460.257	Horizontal	Pass
		2560	2.68	4.75	27.68	25.61	363.915	Horizontal	Pass
5.0MHz Band QPSK	1/#Mid	2502.5	2.17	4.54	27.75	25.38	345.144	Vertical	Pass
		2535	2.68	4.69	27.72	25.71	372.392	Vertical	Pass
		2567.5	2.42	4.71	27.71	25.42	348.33	Vertical	Pass

							7		
10.0MH z Band QPSK	1/#Mid	2505	2.15	4.55	27.76	25.36	343.55 8	Vertical	Pass
		2535	2.66	4.69	27.72	25.69	370.68 1	Vertical	Pass
		2565	2.35	4.72	27.70	25.33	341.19 3	Vertical	Pass
15.0MH z Band QPSK	1/#Mid	2507.5	2.63	4.55	27.77	25.85	384.59 2	Vertical	Pass
		2535	3.08	4.69	27.72	26.11	408.31 9	Vertical	Pass
		2562.5	2.67	4.72	27.69	25.64	366.43 8	Vertical	Pass
20.0MH z Band QPSK	1/#Mid	2510	2.17	4.57	27.78	25.38	345.14 4	Vertical	Pass
		2535	2.64	4.73	27.72	25.63	365.59 5	Vertical	Pass
		2560	2.30	4.75	27.68	25.23	333.42 6	Vertical	Pass

Radiated Power (EIRP) for Band 7									
Mode	RB Size / RB Position	Frequency	Result						Conclusion
			SG Level (dBm)	Cable Loss (dBm)	Antenna Gain (dB)	Max. EIRP Average (dBm)	Max. EIRP Average (mW)	Polarization Of Max. ERP	
5.0MHz Band 16 QAM	1/#Mid	2502.5	1.81	4.54	27.75	25.02	317.687	Horizontal	Pass
		2535	2.45	4.69	27.72	25.48	353.183	Horizontal	Pass
		2567.5	1.85	4.71	27.71	24.85	305.492	Horizontal	Pass
10.0MHz Band 16 QAM	1/#Mid	2505	1.94	4.55	27.76	25.15	327.341	Horizontal	Pass
		2535	2.08	4.69	27.72	25.11	324.340	Horizontal	Pass
		2565	1.90	4.72	27.70	24.88	307.610	Horizontal	Pass
15.0MHz Band 16 QAM	1/#Mid	2507.5	1.25	4.55	27.77	24.47	279.898	Horizontal	Pass
		2535	1.56	4.69	27.72	24.59	287.740	Horizontal	Pass
		2562.5	1.60	4.72	27.69	24.57	286.418	Horizontal	Pass
20.0MHz Band 16 QAM	1/#Mid	2510	1.69	4.57	27.78	24.90	309.030	Horizontal	Pass
		2535	2.56	4.73	27.72	25.55	358.922	Horizontal	Pass
		2560	1.68	4.75	27.68	24.61	289.068	Horizontal	Pass
5.0MHz Band 16 QAM	1/#Mid	2502.5	1.33	4.54	27.75	24.54	284.446	Vertical	Pass
		2535	1.91	4.69	27.72	24.94	311.889	Vertical	Pass
		2567.5	1.59	4.71	27.71	24.59	287.740	Vertical	Pass
10.0MHz Band 16 QAM	1/#Mid	2505	1.40	4.55	27.76	24.61	289.068	Vertical	Pass
		2535	1.86	4.69	27.72	24.89	308.319	Vertical	Pass
		2565	1.76	4.72	27.70	24.74	297.852	Vertical	Pass
15.0MHz Band 16 QAM	1/#Mid	2507.5	1.56	4.55	27.77	24.78	300.608	Vertical	Pass
		2535	1.95	4.69	27.72	24.98	314.775	Vertical	Pass
		2562.5	1.50	4.72	27.69	24.47	279.898	Vertical	Pass
20.0MHz Band 16 QAM	1/#Mid	2510	1.19	4.57	27.78	24.40	275.423	Vertical	Pass
		2535	1.82	4.73	27.72	24.81	302.691	Vertical	Pass
		2560	1.72	4.75	27.68	24.65	291.743	Vertical	Pass

Note:

SG Level= Signal generator output

Max. EIRP Average (dBm)= Antenna Gain(dB)+ SG Level (dBm)- Cable Loss(dBm)



## 9. SPURIOUS RADIATION EMISSION

### RULE PART(S)

FCC: §2.1051, §24.238(a), §27.53(c)(g)(h)(m)

### LIMIT

For Band 7, the minimum permissible attenuation level of any spurious emission is  $55 + \log_{10}(P)$  [Watts].

The minimum permissible attenuation level of any spurious emission is  $43 + \log_{10}(P)$  [Watts], where P is the transmitter power in Watts.

### TEST PROCEDURE

For Cellular equipment - Compliance with these rules is based on the use of measurement instrumentation employing a resolution bandwidth of 100 kHz or greater. In the 1 MHz bands immediately outside and adjacent to the frequency block a resolution bandwidth of at least one percent of the emission bandwidth of the fundamental emission of the transmitter may be employed. A narrower resolution bandwidth is permitted in all cases to improve measurement accuracy provided the measured power is integrated over the full required measurement bandwidth (i.e. 100 kHz or 1 percent of emission bandwidth, as specified). The emission bandwidth is defined as the width of the signal between two points, one below the carrier center frequency and one above the carrier center frequency, outside of which all emissions are attenuated at least 26 dB below the transmitter power.

For PCS equipment - Compliance with these rules is based on the use of measurement instrumentation employing a resolution bandwidth of 1 MHz or greater. However, in the 1 MHz bands immediately outside and adjacent to the frequency block a resolution bandwidth of at least one percent of the emission bandwidth of the fundamental emission of the transmitter may be employed. A narrower resolution bandwidth is permitted in all cases to improve measurement accuracy provided the measured power is integrated over the full required measurement bandwidth ( i.e. 1 MHz or 1 percent of emission bandwidth, as specified). The emission bandwidth is defined as the width of the signal between two points, one below the carrier center frequency and one above the carrier center frequency, outside of which all emissions are attenuated at least 26 dB below the transmitter power.

The unwanted emission power shall be measured with a resolution bandwidth of at least 1% of the occupied bandwidth in the 1 MHz band immediately outside and adjacent to the channel edge of the equipment. Beyond the 1 MHz band immediately outside the channel edge of the equipment, a resolution bandwidth of 1 MHz shall be employed. A narrower resolution bandwidth is allowed to be used provided that the measured power is integrated over the full required measurement bandwidth of 1 MHz or 1% of the occupied bandwidth as applicable.

The power of any unwanted emissions measured from the channel edge of the equipment shall be attenuated below the transmitter power, P (dBW), as follows:

- a. for base station and subscriber equipment, other than mobile subscriber equipment, the attenuation shall not be less than  $43 + 10 \text{ Log}_{10} (p)$ , dB; and
- b. for mobile subscriber equipment, the attenuation shall not be less than  $43 + 10 \text{ Log}_{10} (p)$ , dB at the channel edges and  $55 + 10 \text{ Log}_{10} (p)$  at 5.5 MHz away and beyond the channel edges where p in (a) and (b) is the transmitter power measured in watts.

**MODES TESTED**

- LTE Band 2
- LTE Band 4
- LTE Band 7

**RESULTS**

PASS

9.1 LTE BAND 2

**QPSK EIRP POWER FOR LTE BAND 2 (1.4MHZ BANDWIDTH)**

Test Results for Low Channel 1850.7MHz							
Frequency(MHz)	SG Level(dBm)	Cable Loss(dB)	Antenna Gain(dB)	Absolute Level(dBm)	Limit (dBm)	Margin(dBm)	Polarity
3701.4	-50.55	4.04	33.51	-21.08	-13	-8.08	Horizontal
3701.4	-52.45	4.04	33.51	-22.98	-13	-9.98	Vertical
5552.1	-52.45	5.24	35.84	-21.85	-13	-8.85	Vertical
5552.1	-48.98	5.24	35.84	-18.38	-13	-5.38	Horizontal
188.2	-39.50	1.43	16.02	-24.91	-13	-11.91	Vertical
313.3	-39.04	1.30	17.99	-22.35	-13	-9.35	Horizontal
Test Results for Mid Channel 1880MHz							
3760.0	-49.54	4.04	33.56	-20.02	-13	-7.02	Horizontal
3760.0	-47.88	4.04	33.56	-18.36	-13	-5.36	Vertical
5640.0	-50.09	5.24	35.91	-19.42	-13	-6.42	Vertical
5640.0	-51.40	5.24	35.91	-20.73	-13	-7.73	Horizontal
201.0	-34.74	1.62	16.97	-19.39	-13	-6.39	Vertical
368.1	-38.81	1.74	15.98	-24.58	-13	-11.58	Horizontal
Test Results for High Channel 1909.3MHz							
3818.6	-49.70	4.04	34.00	-19.74	-13	-6.74	Horizontal
3818.6	-51.29	4.04	34.00	-21.33	-13	-8.33	Vertical
5727.9	-53.92	5.24	36.04	-23.12	-13	-10.12	Vertical
5727.9	-54.08	5.24	36.04	-23.28	-13	-10.28	Horizontal
212.4	-38.83	1.42	17.29	-22.96	-13	-9.96	Vertical
441.7	-36.75	1.50	17.90	-20.34	-13	-7.34	Horizontal

**QPSK EIRP POWER FOR LTE BAND 2 (20.0MHZ BANDWIDTH)**

Test Results for Low Channel 1860MHz							
Frequency(MHz)	SG Level(dBm)	Cable Loss(dB)	Antenna Gain(dB)	Absolute Level(dBm)	Limit (dBm)	Margin(dBm)	Polarity
3720.0	-54.30	4.07	33.54	-24.83	-13	-11.83	Horizontal
3720.0	-54.39	4.07	33.54	-24.92	-13	-11.92	Vertical
5580.0	-48.51	5.28	35.86	-17.93	-13	-4.93	Vertical
5580.0	-50.45	5.28	35.86	-19.87	-13	-6.87	Horizontal
196.4	-39.91	1.58	16.89	-24.59	-13	-11.59	Vertical
430.1	-42.83	1.76	17.26	-27.33	-13	-14.33	Horizontal
Test Results for Mid Channel 1880MHz							
3760.0	-56.48	4.04	33.56	-26.96	-13	-13.96	Horizontal
3760.0	-53.91	4.04	33.56	-24.39	-13	-11.39	Vertical
5640.0	-54.67	5.24	35.91	-24.00	-13	-11.00	Vertical
5640.0	-47.84	5.24	35.91	-17.17	-13	-4.17	Horizontal
204.1	-41.67	1.46	16.27	-26.86	-13	-13.86	Vertical
266.4	-37.38	1.59	15.15	-23.82	-13	-10.82	Horizontal
Test Results for High Channel 1900MHz							
3800.0	-53.16	4.04	34.00	-23.20	-13	-10.20	Horizontal
3800.0	-50.76	4.04	34.00	-20.80	-13	-7.80	Vertical
5700.0	-55.15	5.24	36.04	-24.35	-13	-11.35	Vertical
5700.0	-53.95	5.24	36.04	-23.15	-13	-10.15	Horizontal
194.7	-40.13	1.36	17.39	-24.09	-13	-11.09	Vertical
365.0	-41.00	1.66	15.39	-27.27	-13	-14.27	Horizontal

Note:  $P_{Mea}(dBm) = Power(dBm) + ARpl(dBm)$

Over Limit =  $P_{Mea}(dBm) - Limit(dBm)$

Both QPSK and 16QAM has been tested, the worst case is QPSK mode, the report just reported the worst case.

Other emissions are attenuated 20dB below the limit that does not recorded in the report.

9.2 LTE BAND 4

**QPSK EIRP POWER FOR LTE BAND 4 (1.4MHZ BANDWIDTH)**

<b>Test Results for Low Channel 1710.7MHz</b>							
Frequency(MHz)	SG Level(dBm)	Cable Loss(dB)	Antenna Gain(dB)	Absolute Level(dBm)	Limit (dBm)	Margin(dBm)	Polarity
3421.4	-56.55	4.02	29.80	-30.77	-13	-17.77	Horizontal
3421.4	-53.74	4.02	29.80	-27.96	-13	-14.96	Vertical
5132.1	-51.44	5.24	35.84	-20.84	-13	-7.84	Vertical
5132.1	-54.77	5.24	35.84	-24.17	-13	-11.17	Horizontal
188.6	-43.96	1.68	16.04	-29.60	-13	-16.60	Vertical
379.1	-35.74	1.78	17.74	-19.78	-13	-6.78	Horizontal
<b>Test Results for Mid Channel 1732.5MHz</b>							
3465.0	-51.48	4.03	30.00	-25.51	-13	-12.51	Horizontal
3465.0	-53.80	4.03	30.00	-27.83	-13	-14.83	Vertical
5197.5	-51.96	5.25	35.86	-21.35	-13	-8.35	Vertical
5197.5	-47.25	5.25	35.86	-16.64	-13	-3.64	Horizontal
210.2	-39.54	1.72	17.69	-23.57	-13	-10.57	Vertical
388.5	-36.39	1.62	16.02	-21.98	-13	-8.98	Horizontal
<b>Test Results for High Channel 1754.3MHz</b>							
3508.6	-53.87	4.05	30.01	-27.91	-13	-14.91	Horizontal
3508.6	-52.01	4.05	30.01	-26.05	-13	-13.05	Vertical
5262.9	-54.34	5.26	35.86	-23.74	-13	-10.74	Vertical
5262.9	-47.93	5.26	35.86	-17.33	-13	-4.33	Horizontal
207.1	-38.77	1.80	16.69	-23.88	-13	-10.88	Vertical
421.7	-44.94	1.75	16.66	-30.04	-13	-17.04	Horizontal

**QPSK EIRP POWER FOR LTE BAND 4 (20.0MHZ BANDWIDTH)**

Test Results for Low Channel 1720MHz							
Frequency(MHz)	SG Level(dBm)	Cable Loss(dB)	Antenna Gain(dB)	Absolute Level(dBm)	Limit (dBm)	Margin(dBm)	Polarity
3440.0	-54.57	4.02	29.80	-28.79	-13	-15.79	Horizontal
3440.0	-56.36	4.02	29.80	-30.58	-13	-17.58	Vertical
5160.0	-47.17	5.24	35.84	-16.57	-13	-3.57	Vertical
5160.0	-56.12	5.24	35.84	-25.52	-13	-12.52	Horizontal
201.0	-37.45	1.57	17.26	-21.76	-13	-8.76	Vertical
438.9	-36.42	1.78	16.35	-21.85	-13	-8.85	Horizontal
Test Results for Mid Channel 1732.5MHz							
3465.0	-52.68	4.03	30.00	-26.71	-13	-13.71	Horizontal
3465.0	-51.98	4.03	30.00	-26.01	-13	-13.01	Vertical
5197.5	-47.45	5.25	35.86	-16.84	-13	-3.84	Vertical
5197.5	-48.95	5.25	35.86	-18.34	-13	-5.34	Horizontal
181.7	-37.62	1.44	17.95	-21.11	-13	-8.11	Vertical
235.0	-37.34	1.65	16.09	-22.90	-13	-9.90	Horizontal
Test Results for High Channel 1745MHz							
3490.0	-56.36	2.91	27.68	-31.59	-13	-18.59	Horizontal
3490.0	-47.22	2.91	27.68	-22.45	-13	-9.45	Vertical
5235.0	-51.77	5.26	35.86	-21.17	-13	-8.17	Vertical
5235.0	-53.27	5.26	35.86	-22.67	-13	-9.67	Horizontal
207.4	-34.97	1.61	16.85	-19.73	-13	-6.73	Vertical
268.8	-44.32	1.61	15.19	-30.74	-13	-17.74	Horizontal

Note: P<sub>Mea</sub>(dBm)= Power(dBm)+ ARpl (dBm)

Over Limit= : P<sub>Mea</sub>(dBm)-Limit(dBm)

Both QPSK and 16QAM has been tested, the worst case is QPSK mode, the report just reported the worst case.

Other emissions are attenuated 20dB below the limit that does not recorded in the report.

9.3 LTE BAND 7

**QPSK EIRP POWER FOR LTE BAND 7 (5.0MHZ BANDWIDTH)**

<b>Test Results for Low Channel 2502.5MHz</b>							
Frequency(MHz)	SG Level(dBm)	Cable Loss(dB)	Antenna Gain(dB)	Absolute Level(dBm)	Limit (dBm)	Margin(dBm)	Polarity
5005.0	-62.18	5.23	35.81	-31.60	-25	-6.60	Horizontal
5005.0	-64.49	5.23	35.81	-33.91	-25	-8.91	Vertical
7507.5	-62.31	5.67	36.85	-31.13	-25	-6.13	Vertical
7507.5	-67.66	5.67	36.85	-36.48	-25	-11.48	Horizontal
190.3	-45.63	1.73	17.97	-29.39	-25	-4.39	Vertical
236.8	-53.67	1.38	15.11	-39.94	-25	-14.94	Horizontal
<b>Test Results for Mid Channel 2535MHz</b>							
5070.0	-65.41	5.23	35.82	-34.82	-25	-9.82	Horizontal
5070.0	-63.46	5.23	35.82	-32.87	-25	-7.87	Vertical
7605.0	-66.30	5.67	36.85	-35.12	-25	-10.12	Vertical
7605.0	-64.31	5.67	36.85	-33.13	-25	-8.13	Horizontal
187.5	-50.27	1.77	16.17	-35.86	-25	-10.86	Vertical
325.6	-45.94	1.63	15.21	-32.36	-25	-7.36	Horizontal
<b>Test Results for High Channel 2567.5MHz</b>							
5135.0	-67.66	5.24	35.83	-37.07	-25	-12.07	Horizontal
5135.0	-65.39	5.24	35.83	-34.80	-25	-9.80	Vertical
7702.5	-63.84	5.68	36.87	-32.65	-25	-7.65	Vertical
7702.5	-66.43	5.68	36.87	-35.24	-25	-10.24	Horizontal
197.3	-54.07	1.58	17.56	-38.09	-25	-13.09	Vertical
416.2	-49.76	1.45	16.58	-34.63	-25	-9.63	Horizontal

**QPSK EIRP POWER FOR LTE BAND 7 (20.0MHZ BANDWIDTH)**

Test Results for Low Channel 2510MHz							
Frequency(MHz)	SG Level(dBm)	Cable Loss(dB)	Antenna Gain(dB)	Absolute Level(dBm)	Limit (dBm)	Margin(dBm)	Polarity
5020.0	-65.38	5.23	35.82	-34.79	-25	-9.79	Horizontal
5020.0	-67.77	5.23	35.82	-37.18	-25	-12.18	Vertical
7530.0	-67.84	5.67	36.86	-36.65	-25	-11.65	Vertical
7530.0	-63.93	5.67	36.86	-32.74	-25	-7.74	Horizontal
208.3	-52.85	1.63	15.76	-38.72	-25	-13.72	Vertical
453.4	-52.63	1.71	15.44	-38.90	-25	-13.90	Horizontal
Test Results for Mid Channel 2535MHz							
5070.0	-67.24	5.23	35.82	-36.65	-25	-11.65	Horizontal
5070.0	-65.73	5.23	35.82	-35.14	-25	-10.14	Vertical
7605.0	-63.93	5.67	36.85	-32.75	-25	-7.75	Vertical
7605.0	-63.90	5.67	36.85	-32.72	-25	-7.72	Horizontal
197.4	-49.75	1.79	16.84	-34.69	-25	-9.69	Vertical
357.3	-51.02	1.71	17.64	-35.09	-25	-10.09	Horizontal
Test Results for High Channel 2560MHz							
5120.0	-62.91	5.24	35.83	-32.32	-25	-7.32	Horizontal
5120.0	-62.79	5.24	35.83	-32.20	-25	-7.20	Vertical
7680.0	-66.59	5.70	36.88	-35.41	-25	-10.41	Vertical
7680.0	-64.81	5.70	36.88	-33.63	-25	-8.63	Horizontal
182.8	-48.46	1.79	16.84	-33.40	-25	-8.40	Vertical
249.1	-45.49	1.71	17.64	-29.56	-25	-4.56	Horizontal

Note:  $P_{Mea}(dBm) = Power(dBm) + ARpl (dBm)$

. Over Limit = :  $P_{Mea}(dBm) - Limit(dBm)$

. Both QPSK and 16QAM has been tested, the worst case is QPSK mode, the report just reported the worst case.

Other emissions are attenuated 20dB below the limit that does not recorded in the report.



## 10. FREQUENCY STABILITY

### RULE PART(S)

FCC: §2.1055, §24.235, §27.54

### LIMITS

§24.235 - The frequency stability shall be sufficient to ensure that the fundamental emission stays within the authorized frequency block.

### TEST PROCEDURE

Use CMW 500 with Frequency Error measurement capability.

- Temp. =  $-30^{\circ}$  to  $+50^{\circ}\text{C}$
- Voltage = low voltage, DC 3.4V, Normal, DC 3.85V and High voltage, DC 4.2V.

### Frequency Stability vs Temperature:

The EUT is placed inside a temperature chamber. The temperature is set to  $-30^{\circ}\text{C}$  and allowed to stabilize. After sufficient soak time, the transmitting frequency error is measured. The temperature is increased by 10 degrees, allowed to stabilize and soak, and then the measurement is repeated. This is repeated until  $+50^{\circ}\text{C}$  is reached.

### Frequency Stability vs Voltage:

The peak frequency error is recorded (worst-case).

### MODES TESTED

- LTE Band 2
- LTE Band 4
- LTE Band 7

## RESULTS

See the following pages.

10.1 LTE BAND 2

QPSK, (20MHz BANDWIDTH)

**Frequency error vs. Voltage**

Voltage [Vdc]	Frequency [MHz]	Frequency* Error[Hz]	Frequency Error[ppm]	Limit [ppm]
<b>BAND 2 QPSK, (CH 18900 RB size 100 RB Offset 0 20MHz BANDWIDTH)</b>				
3.4	1880	12.3	0.006531	2.5
3.85	1880	13.7	0.007295	2.5
4.2	1880	13.3	0.007090	2.5

**Frequency error vs. Temperature**

Temperature [° C]	Frequency [MHz]	Frequency* Error[Hz]	Frequency Error[ppm]	Limit [ppm]
<b>BAND 2 QPSK, (CH 18900 RB size 100 RB Offset 0 20MHz BANDWIDTH)</b>				
Normal (25C)	1880	13.2	0.006998	2.5
Extreme (50C)	1880	12.0	0.006366	2.5
Extreme (40C)	1880	13.8	0.007343	2.5
Extreme (30C)	1880	13.7	0.007308	2.5
Extreme (10C)	1880	13.8	0.007353	2.5
Extreme (0C)	1880	12.0	0.006370	2.5
Extreme (-10C)	1880	13.2	0.007012	2.5
Extreme (-20C)	1880	13.9	0.007389	2.5
Extreme (-30C)	1880	14.7	0.007842	2.5

**16QAM, (20MHz BANDWIDTH)**

**Frequency error vs. Voltage**

Voltage [Vdc]	Frequency [MHz]	Frequency* Error[Hz]	Frequency Error[ppm]	Limit [ppm]
<b>BAND 2 16QAM, (CH 18900 RB size 100 RB Offset 0 20MHz BANDWIDTH)</b>				
3.4	1880	9.8	0.005224	2.5
3.85	1880	8.7	0.004638	2.5
4.2	1880	7.6	0.004045	2.5

**Frequency error vs. Temperature**

Temperature [° C]	Frequency [MHz]	Frequency* Error[Hz]	Frequency Error[ppm]	Limit [ppm]
<b>BAND 2 16QAM, (CH 18900 RB size 100 RB Offset 0 20MHz BANDWIDTH)</b>				
Normal (25C)	1880	9.6	0.005088	2.5
Extreme (50C)	1880	8.9	0.004735	2.5
Extreme (40C)	1880	8.3	0.00441211	2.5
Extreme (30C)	1880	9.2	0.004905933	2.5
Extreme (10C)	1880	9.3	0.004937446	2.5
Extreme (0C)	1880	8.0	0.004279427	2.5
Extreme (-10C)	1880	9.1	0.004847342	2.5
Extreme (-20C)	1880	8.8	0.004687687	2.5
Extreme (-30C)	1880	7.7	0.004097695	2.5

\*Note: Frequency error measurements were made by using the build-in capability of the Wireless Communication Test Set.

10.2 LTE BAND 4

QPSK, (10MHz BANDWIDTH)

**Frequency error vs. Voltage**

Voltage [Vdc]	Frequency [MHz]	Frequency* Error[Hz]	Frequency Error[ppm]	Limit [ppm]
<b>BAND 4 QPSK, (CH 20175 RB size 100 RB Offset 0 20MHz BANDWIDTH)</b>				
3.4	1732.5	8.9	0.005146	2.5
3.85	1732.5	8.5	0.004913	2.5
4.2	1732.5	8.9	0.005127	2.5

**Frequency error vs. Temperature**

Temperature [°C]	Frequency [MHz]	Frequency* Error[Hz]	Frequency Error[ppm]	Limit [ppm]
<b>BAND 4 QPSK, (CH 20175 RB size 100 RB Offset 0 20MHz BANDWIDTH)</b>				
Normal (25C)	1732.5	8.6	0.004973	2.5
Extreme (50C)	1732.5	8.9	0.005159	2.5
Extreme (40C)	1732.5	7.0	0.004058	2.5
Extreme (30C)	1732.5	5.5	0.003193	2.5
Extreme (10C)	1732.5	7.4	0.004275	2.5
Extreme (0C)	1732.5	9.5	0.005468	2.5
Extreme (-10C)	1732.5	8.6	0.004943	2.5
Extreme (-20C)	1732.5	6.8	0.003925	2.5
Extreme (-30C)	1732.5	8.9	0.005121	2.5

**16QAM, (20MHz BANDWIDTH)**

**Frequency error vs. Voltage**

Voltage [Vdc]	Frequency [MHz]	Frequency* Error[Hz]	Frequency Error[ppm]	Limit [ppm]
<b>BAND 4 16QAM, (CH 20175 RB size 100 RB Offset 0 20MHz BANDWIDTH)</b>				
3.4	1732.5	10.2	0.005879	2.5
3.85	1732.5	8.5	0.004922	2.5
4.2	1732.5	8.1	0.004648	2.5

**Frequency error vs. Temperature**

Temperature [°C]	Frequency [MHz]	Frequency* Error[Hz]	Frequency Error[ppm]	Limit [ppm]
<b>BAND 4 16QAM, (CH 20175 RB size 100 RB Offset 0 20MHz BANDWIDTH)</b>				
Normal (25C)	1732.5	9.4	0.005425	2.5
Extreme (50C)	1732.5	8.4	0.004861	2.5
Extreme (40C)	1732.5	8.5	0.004927	2.5
Extreme (30C)	1732.5	8.8	0.005057	2.5
Extreme (10C)	1732.5	9.1	0.005264	2.5
Extreme (0C)	1732.5	8.0	0.004602	2.5
Extreme (-10C)	1732.5	9.3	0.005386	2.5
Extreme (-20C)	1732.5	9.3	0.005346	2.5
Extreme (-30C)	1732.5	7.6	0.004406	2.5

**\*Note:** Frequency error measurements were made by using the build-in capability of the Wireless Communication Test Set.

10.3 LTE BAND 7

QPSK, (20MHz BANDWIDTH)

**Frequency error vs. Voltage**

Voltage [Vdc]	Frequency [MHz]	Frequency* Error[Hz]	Frequency Error[ppm]	Limit [ppm]
<b>BAND 7 QPSK, (CH 21100 RB size 100 RB Offset 0 20MHz BANDWIDTH)</b>				
3.4	2535	10.3	0.004053	2.5
3.85	2535	9.1	0.003607	2.5
4.2	2535	8.1	0.003212	2.5

**Frequency error vs. Temperature**

Temperature [° C]	Frequency [MHz]	Frequency* Error[Hz]	Frequency Error[ppm]	Limit [ppm]
<b>BAND 7 QPSK, (CH 21100 RB size 100 RB Offset 0 20MHz BANDWIDTH)</b>				
Normal (25C)	2535	9.4	0.003726	2.5
Extreme (50C)	2535	9.3	0.003668	2.5
Extreme (40C)	2535	8.5	0.003360	2.5
Extreme (30C)	2535	9.2	0.003640	2.5
Extreme (10C)	2535	7.6	0.003003	2.5
Extreme (0C)	2535	8.1	0.003193	2.5
Extreme (-10C)	2535	9.5	0.003731	2.5
Extreme (-20C)	2535	9.3	0.003659	2.5
Extreme (-30C)	2535	8.3	0.003289	2.5

**16QAM, (20MHz BANDWIDTH)**

**Frequency error vs. Voltage**

Voltage [Vdc]	Frequency [MHz]	Frequency* Error[Hz]	Frequency Error[ppm]	Limit [ppm]
<b>BAND 7 16QAM, (CH 21100 RB size 100 RB Offset 0 20MHz BANDWIDTH)</b>				
3.4	2535	6.9	0.002722	2.5
3.85	2535	6.7	0.002627	2.5
4.2	2535	6.0	0.002380	2.5

**Frequency error vs. Temperature**

Temperature [° C]	Frequency [MHz]	Frequency* Error[Hz]	Frequency Error[ppm]	Limit [ppm]
<b>BAND 7 16QAM, (CH 21100 RB size 100 RB Offset 0 20MHz BANDWIDTH)</b>				
Normal (25C)	2535	6.9	0.002722	2.5
Extreme (50C)	2535	6.0	0.002356	2.5
Extreme (40C)	2535	5.1	0.002018	2.5
Extreme (30C)	2535	6.4	0.002521	2.5
Extreme (10C)	2535	6.1	0.002405	2.5
Extreme (0C)	2535	4.6	0.001824	2.5
Extreme (-10C)	2535	5.4	0.002137	2.5
Extreme (-20C)	2535	5.7	0.002237	2.5
Extreme (-30C)	2535	5.8	0.002285	2.5

**\*Note:** Frequency error measurements were made by using the build-in capability of the Wireless Communication Test Set.

## 11. Peak-to-Average Ratio

### 11.1 Description of the PAR Measurement

The peak-to-average ratio (PAR) of the transmission may not exceed 13 dB.

### 11.2 Measuring Instruments

See list of measuring instruments of this test report.

### 11.3 Test Procedures

1. The EUT was connected to Spectrum Analyzer and Base Station via power divider.
2. The RF output of EUT was connected to the spectrum analyzer by RF cable and attenuator. The path loss was compensated to the results for each measurement.
3. For GSM/EGPRS operating modes:
  - a. Set the RBW = 1MHz, VBW = 1MHz, Peak detector in spectrum analyzer.
  - b. Set EUT in maximum power output, and triggered the burst signal.
  - c. Measured respectively the Peak level and Mean level, and the deviation was recorded as Peak to Average Ratio.
4. For UMTS operating modes:
  - a. Set the CCDF (Complementary Cumulative Distribution Function) option in spectrum analyzer.
  - b. The highest RF powers were measured and recorded the maximum PAPR level associated with a probability of 0.1 %.

### 11.4 Test Setup

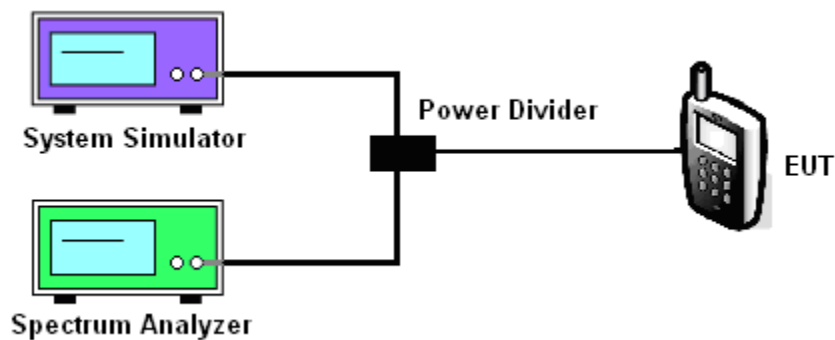

#### MODES TESTED

LTE Band 2/4/7

Test data reference attachment.

----END OF REPORT----