

(Channel 120: 5600MHz @ 802.11n-20MHz)

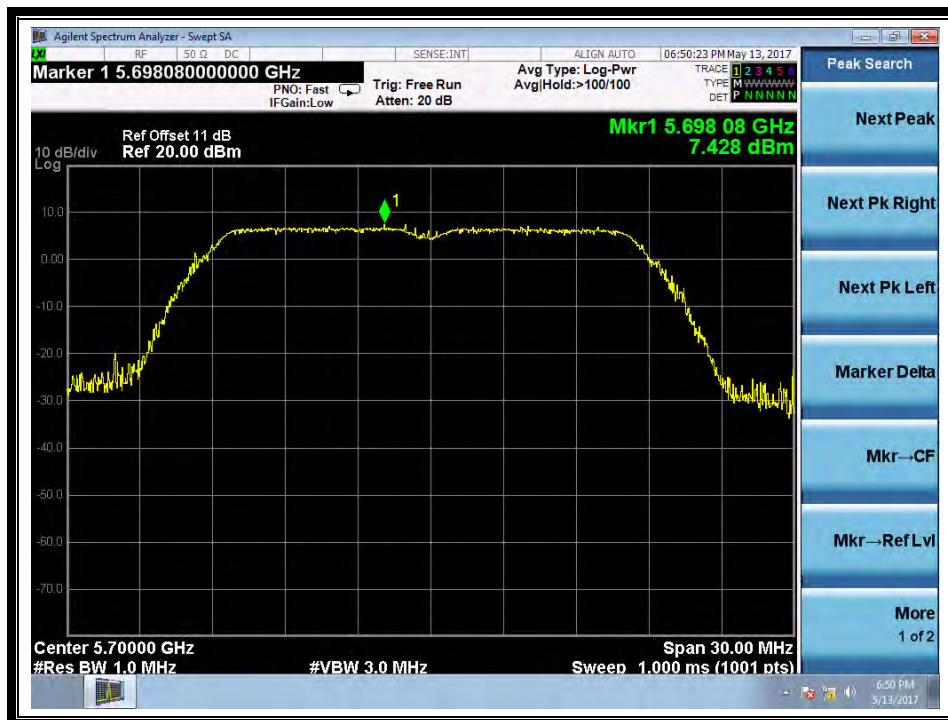

(Channel 140: 5700MHz @ 802.11n-20MHz)

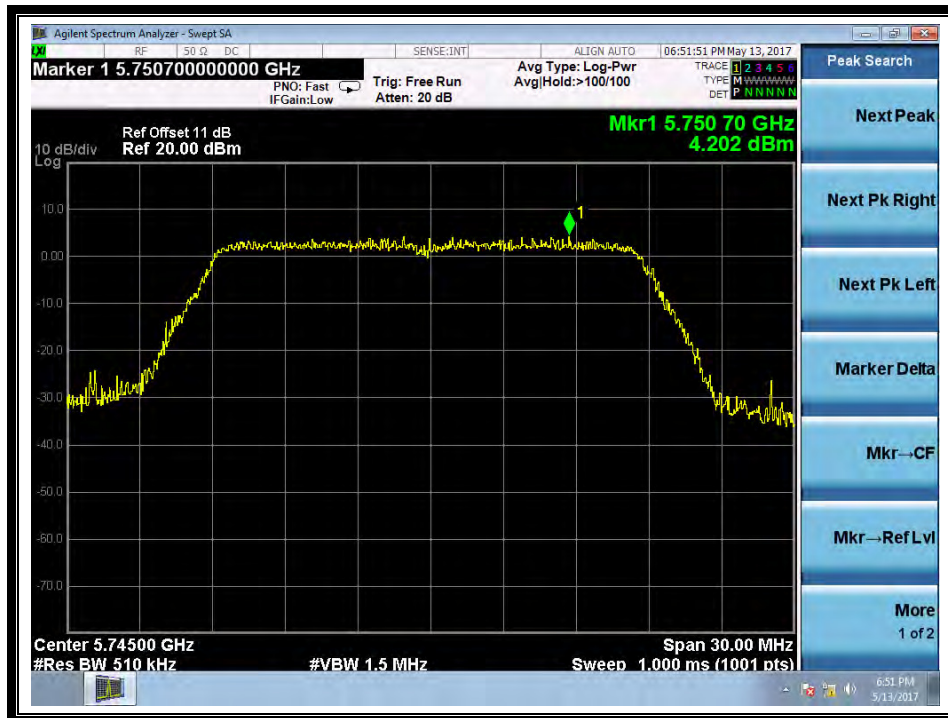

(Channel 149: 5745MHz @ 802.11n-20MHz)

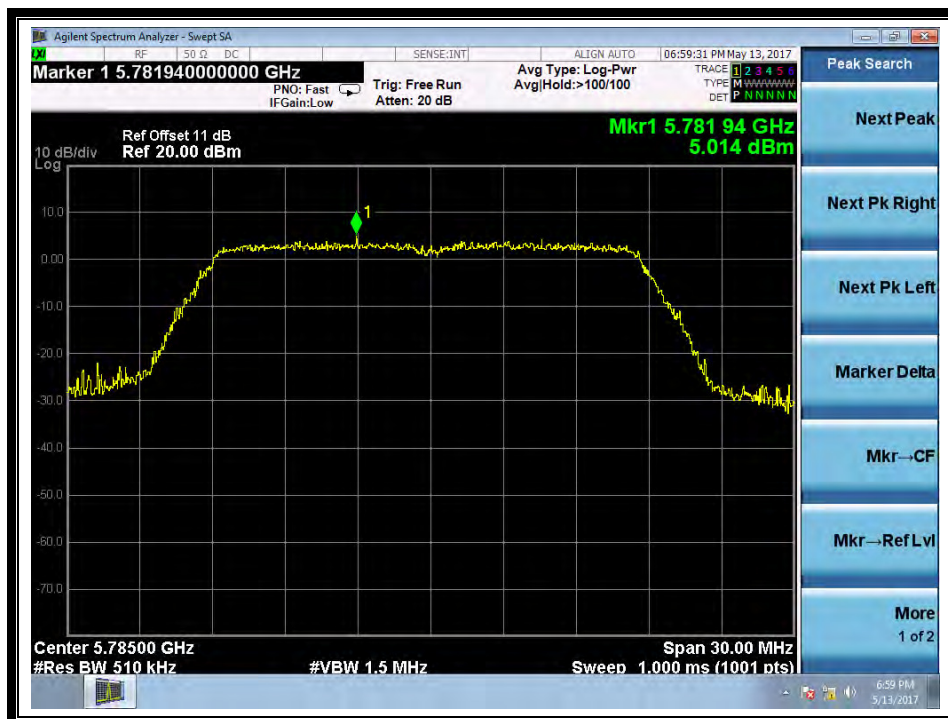

(Channel 157: 5785MHz @802.11n-20MHz)

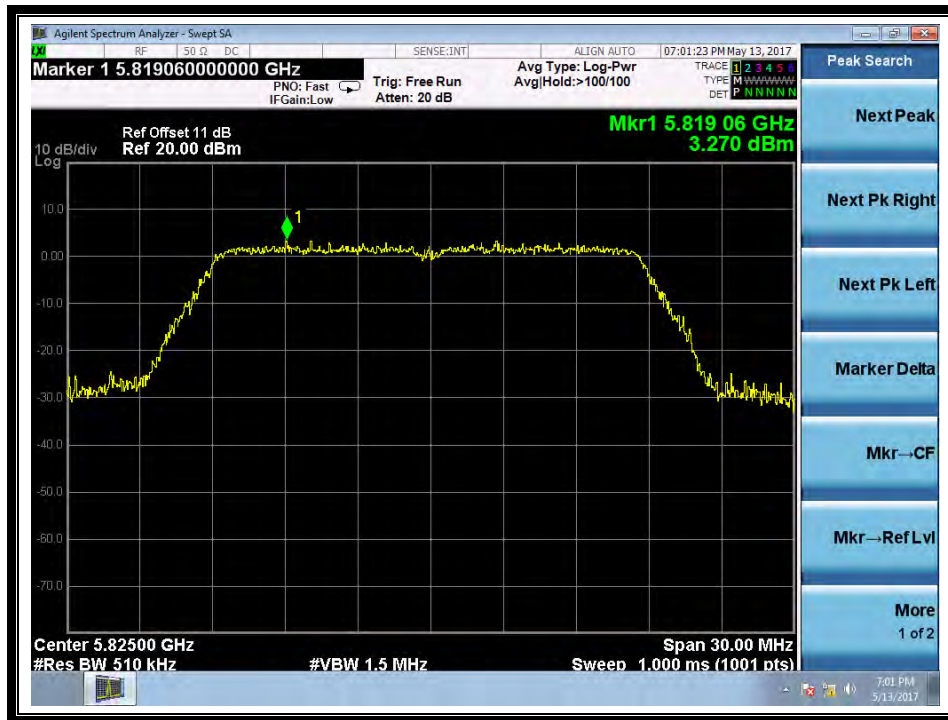

(Channel 165: 5825MHz @ 802.11n-20MHz)

2.4.3.5 802.11n-40MHz Test mode

A. Test Verdict:

Channel	Frequency (MHz)	Measured PPSD (dBm/MHz)	Limit (dBm/MHz)	Verdict
38	5190	1.66	11	PASS
46	5230	1.30		
54	5270	1.51		
62	5310	6.08		
102	5510	8.68		
126	5630	5.21		
142	5710	5.77	U-NII-2C:11dBm/MHz U-NII-3:30dBm/500KHz	
Channel	Frequency (MHz)	Measured PPSD (dBm/500KHz)	Limit (dBm/500KHz)	Verdict
151	5755	1.57	30	PASS
159	5795	0.68		

B. Test Plots

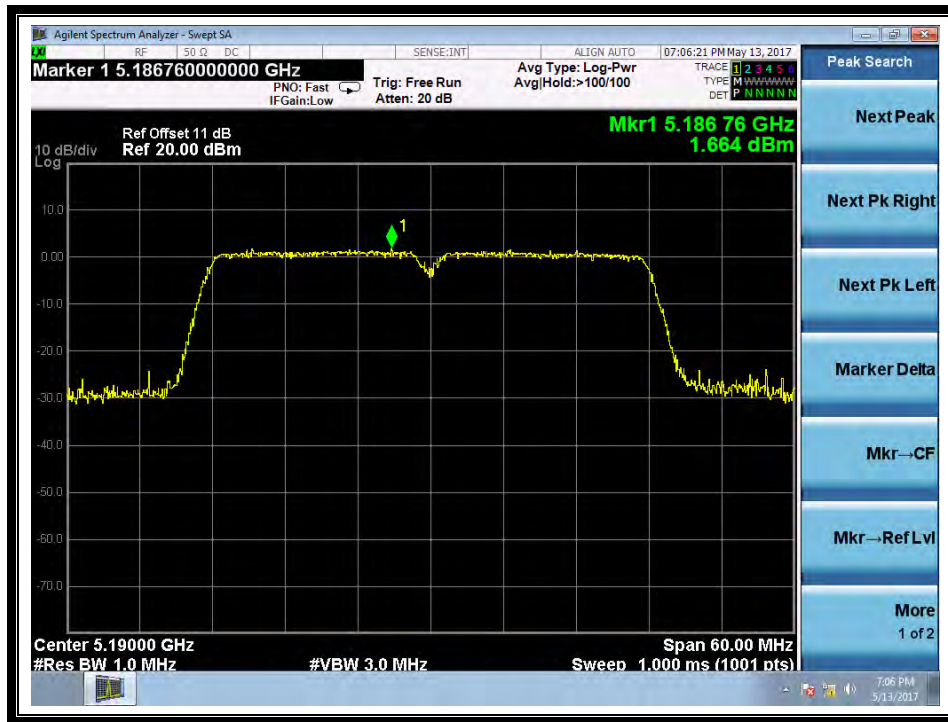

(Channel 38: 5190MHz @ 802.11n-40MHz)

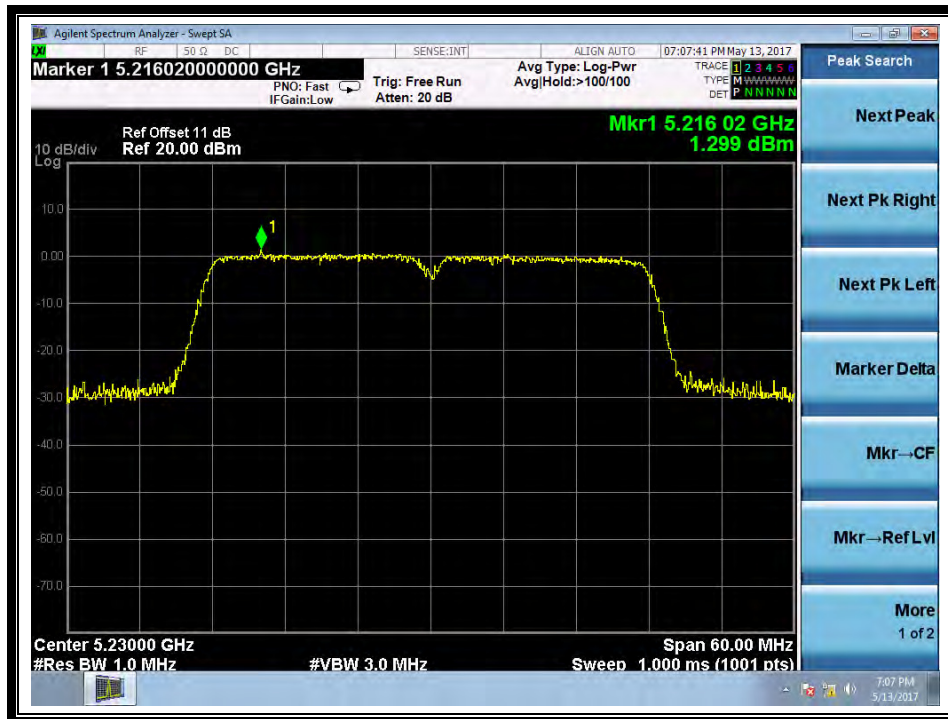

(Channel 46: 5230 MHz @ 802.11n-40MHz)

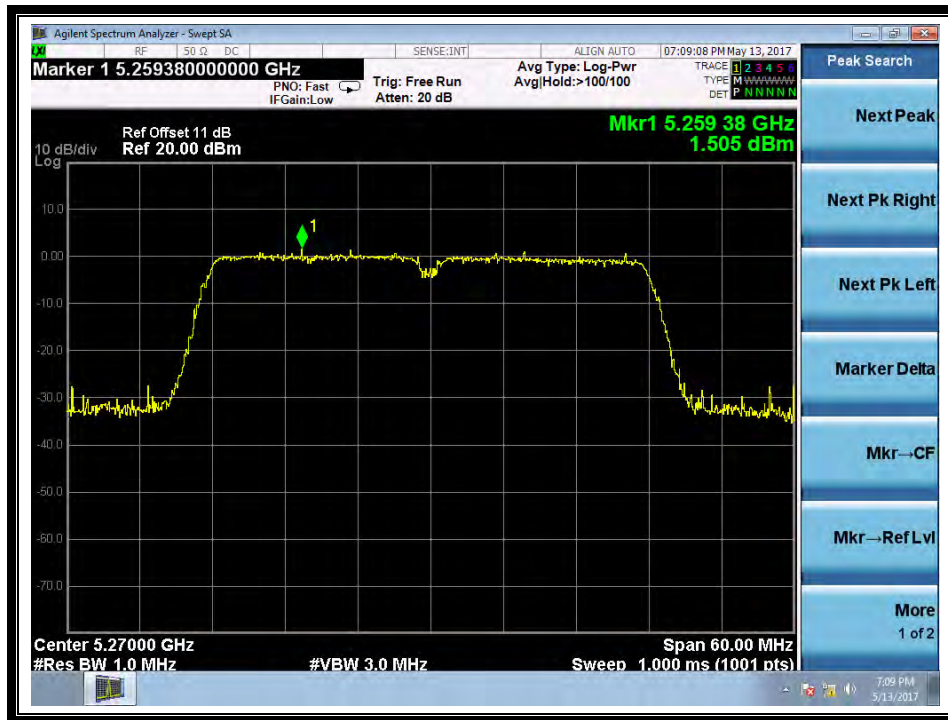

(Channel 54: 5270MHz @802.11n-40MHz)

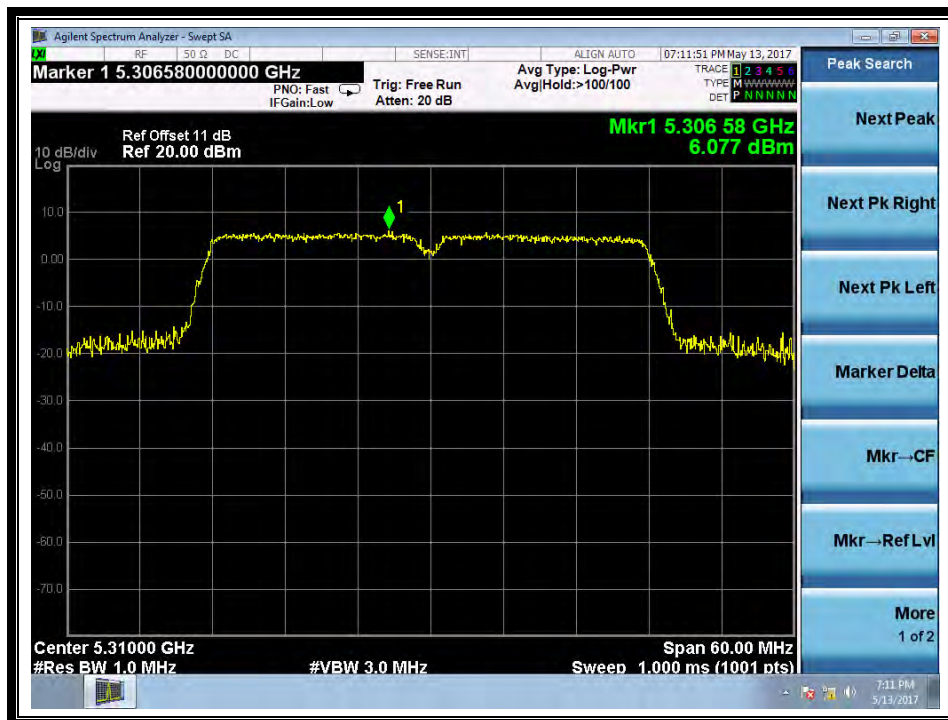

(Channel 62: 5310MHz @ 802.11n-40MHz)

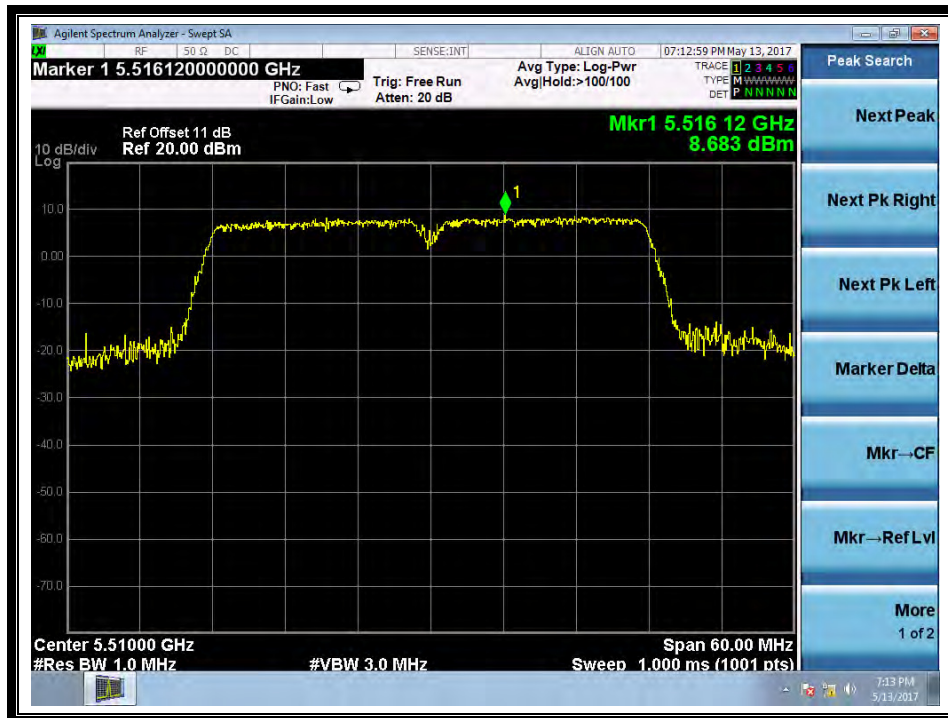

(Channel 102: 5510MHz @802.11n-40MHz)



(Channel 126: 5630MHz @ 802.11n-40MHz)

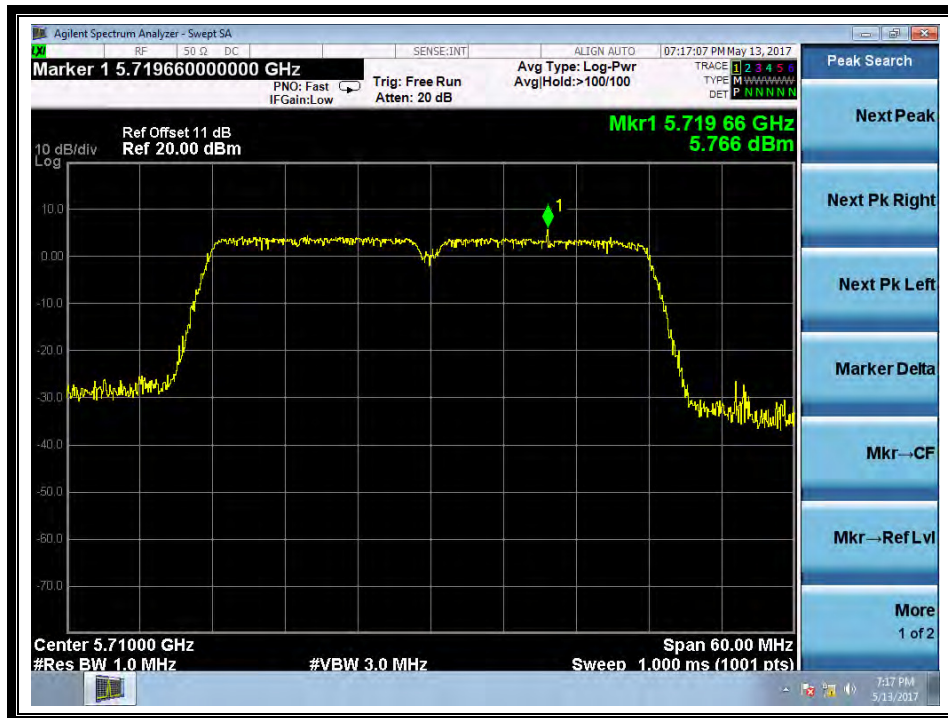

(Channel 142: 5710MHz @ 802.11n-40MHz)



(Channel 151: 5755MHz @ 802.11n-40MHz)

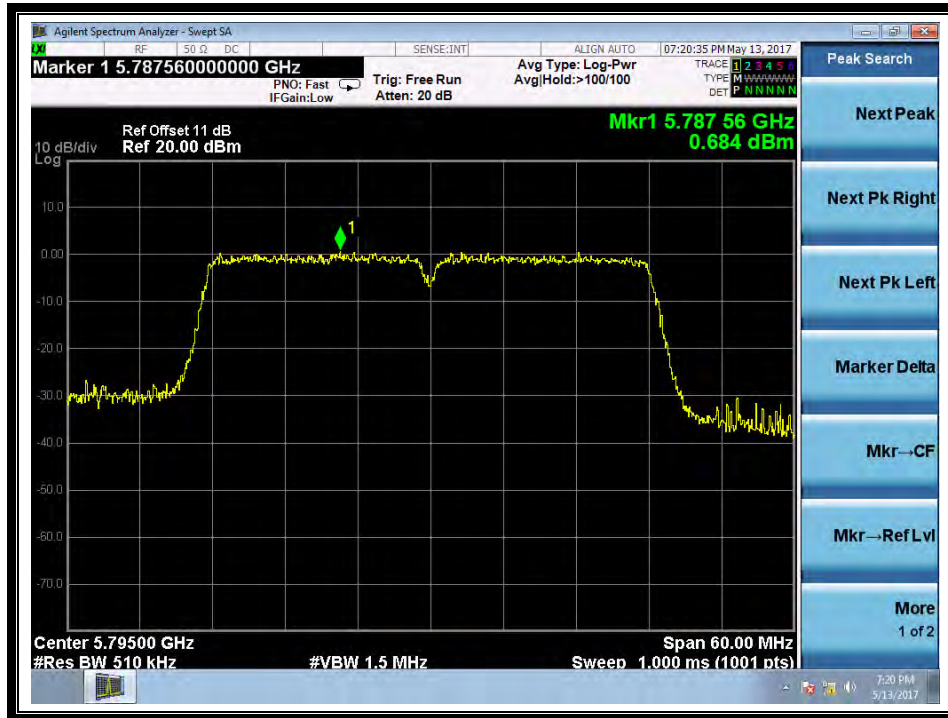

(Channel 159: 5795MHz @802.11n-40MHz)

2.5 Restricted Frequency Bands

2.5.1 Requirement

According to FCC section 15.407(b)(7), in any 100kHz bandwidth outside the frequency band in which the spread spectrum or digitally modulated intentional radiator is operating, the radio frequency power that is produced by the intentional radiator shall be at least 20dB below that in the 100kHz bandwidth within the band that contains the highest level of the desired power, In addition, radiated emissions which fall in the restricted bands, as defined in 15.205(a), must also comply with the radiated emission limits specified in 15.209(a).

2.5.2 Test Description

A. Test Setup

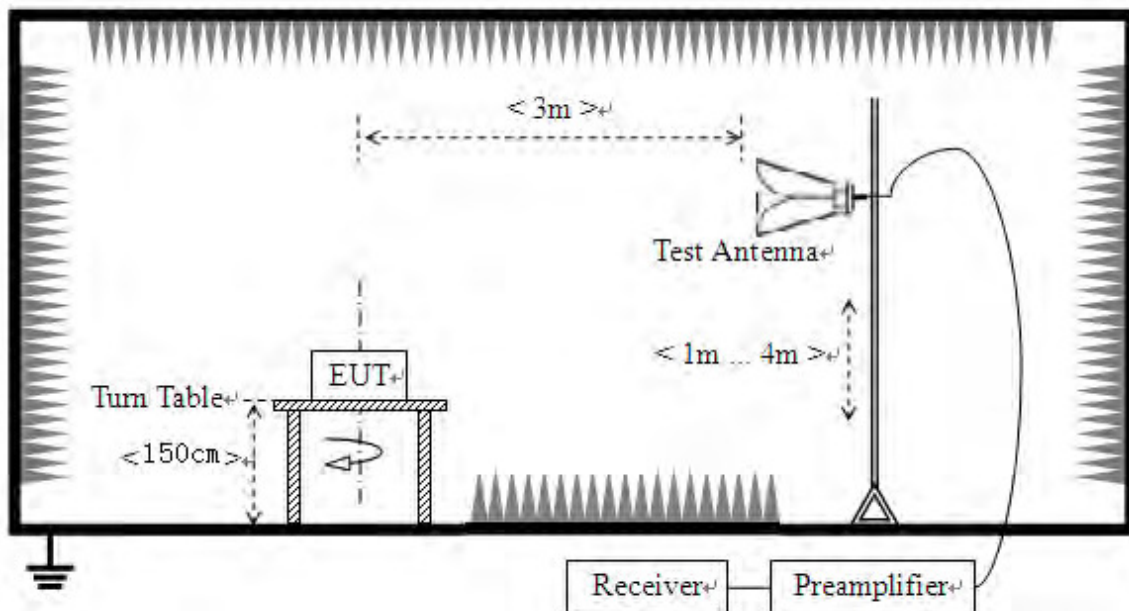

The Module is located in a 3m Semi-Anechoic Chamber; the antenna factors, cable loss and so on of the site as factors are calculated to correct the reading.

KDB 789033 Section H) 3)5)6(d)) was used in order to prove compliance

For the Test Antenna:

Test Antenna is 3m away from the EUT. Test Antenna height is varied from 1m to 4m above the ground to determine the maximum value of the field strength.



2.5.3 Test Result

The lowest and highest channels are tested to verify Restricted Frequency Bands.

The measurement results are obtained as below:

$$E \text{ [dB}\mu\text{V/m]} = U_R + A_T + A_{\text{Factor}} \text{ [dB]}; A_T = L_{\text{Cable loss}} \text{ [dB]} - G_{\text{preamp}} \text{ [dB]}$$

A_T : Total correction Factor except Antenna

U_R : Receiver Reading

G_{preamp} : Preamplifier Gain

A_{Factor} : Antenna Factor at 3m

Note: Restricted Frequency Bands were performed when antenna was at vertical and horizontal polarity, and only the worse test condition (vertical) was recorded in this test report.

2.5.3.1 802.11ac-20MHz Test mode

The lowest and highest channels are tested to verify the band edge emissions.

A. Test Verdict:

Channel	Frequency (MHz)	Detector	Receiver Reading	A_T (dB)	A_{Factor} (dB@3m)	Max. Emission E (dB μ V/m)	Limit (dB μ V/m)	Verdict
		PK/ AV	U_R (dB μ V)					
36	5105.13	PK	44.96	-50.65	32.11	26.42	74	Pass
36	5105.13	AV	33.82	-50.65	32.11	15.28	54	Pass
64	5354.80	PK	41.05	-50.65	32.11	22.51	74	Pass
64	5354.80	AV	32.43	-50.65	32.11	13.89	54	Pass
100	5449.50	PK	39.79	-50.65	32.11	21.25	74	Pass
100	5449.50	AV	32.22	-50.65	32.11	13.68	54	Pass
140	5760.00	PK	45.20	-50.65	32.11	26.66	74	Pass
140	5754.90	AV	33.63	-50.65	32.11	15.09	54	Pass

B. Test Plots:

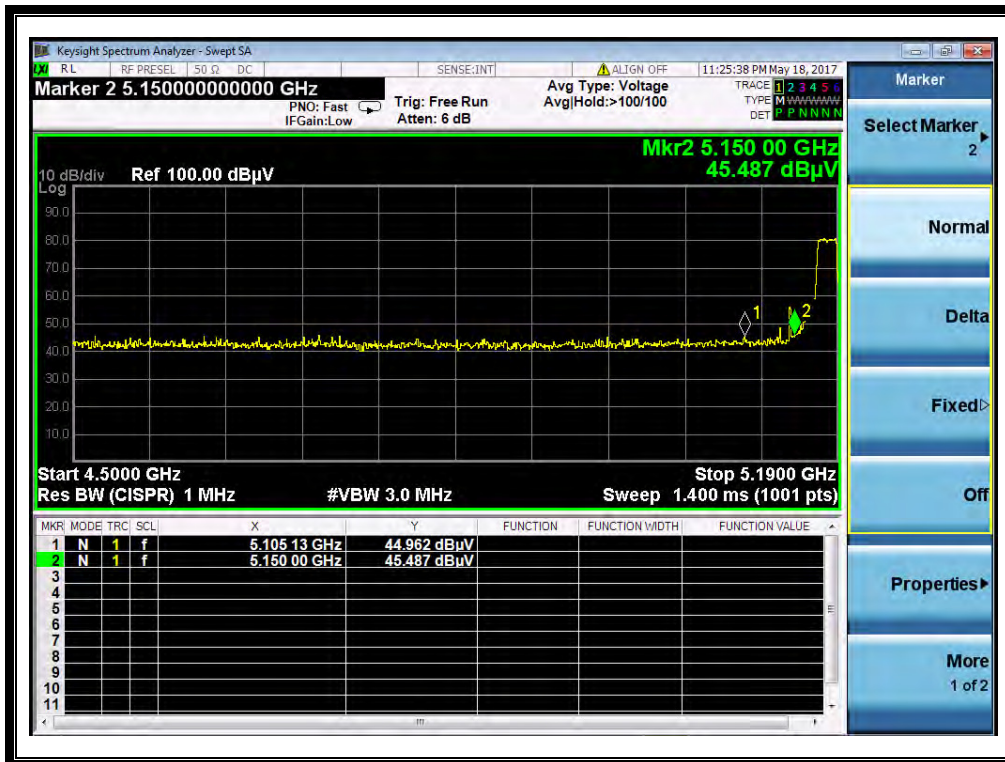

(Channel = 36 PEAK @ 802.11ac)

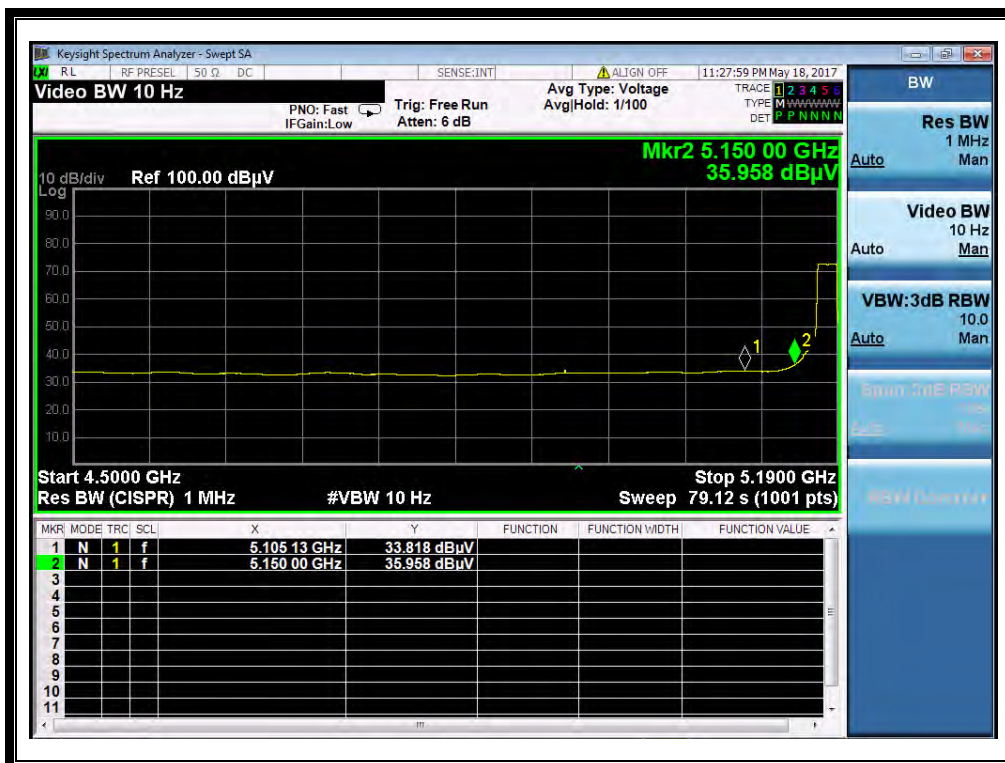

(Channel = 36 AVG @ 802.11ac)

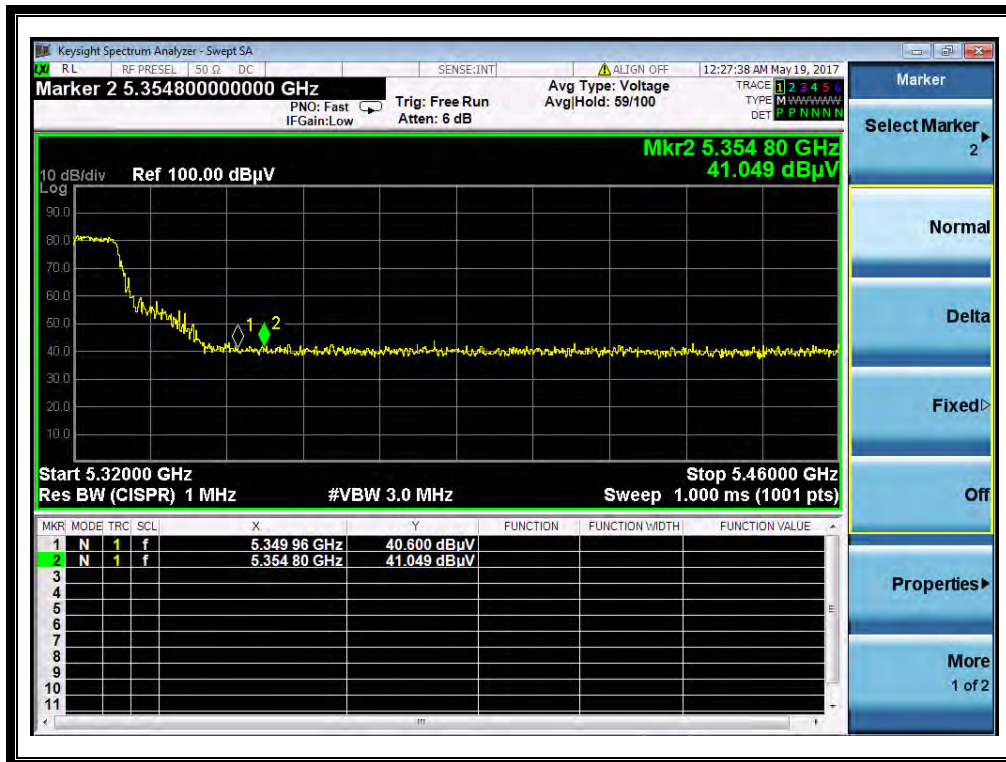

(Channel = 64 PEAK @ 802.11ac)

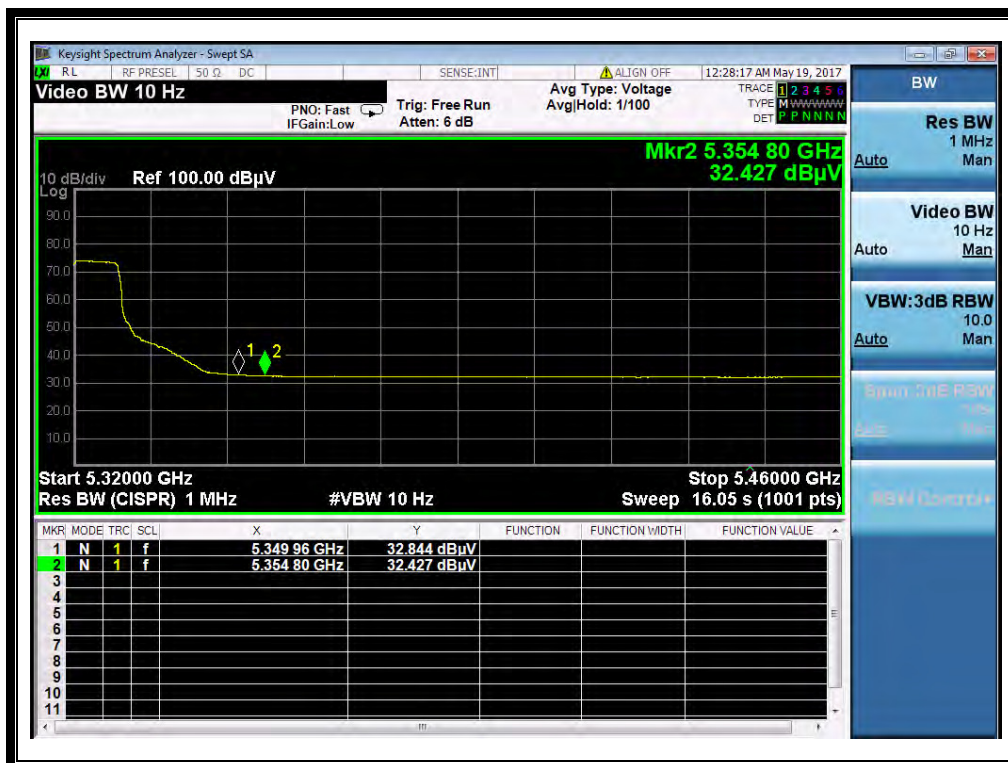

(Channel = 64 AVG @ 802.11ac)

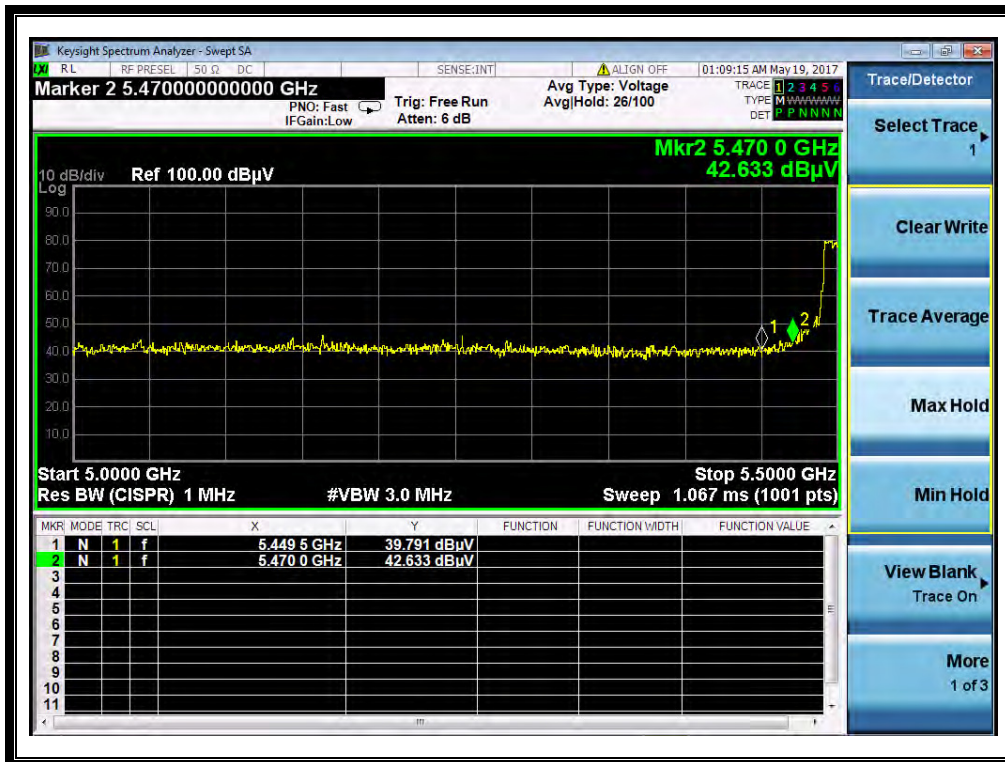

(Channel = 100 PEAK @ 802.11ac)

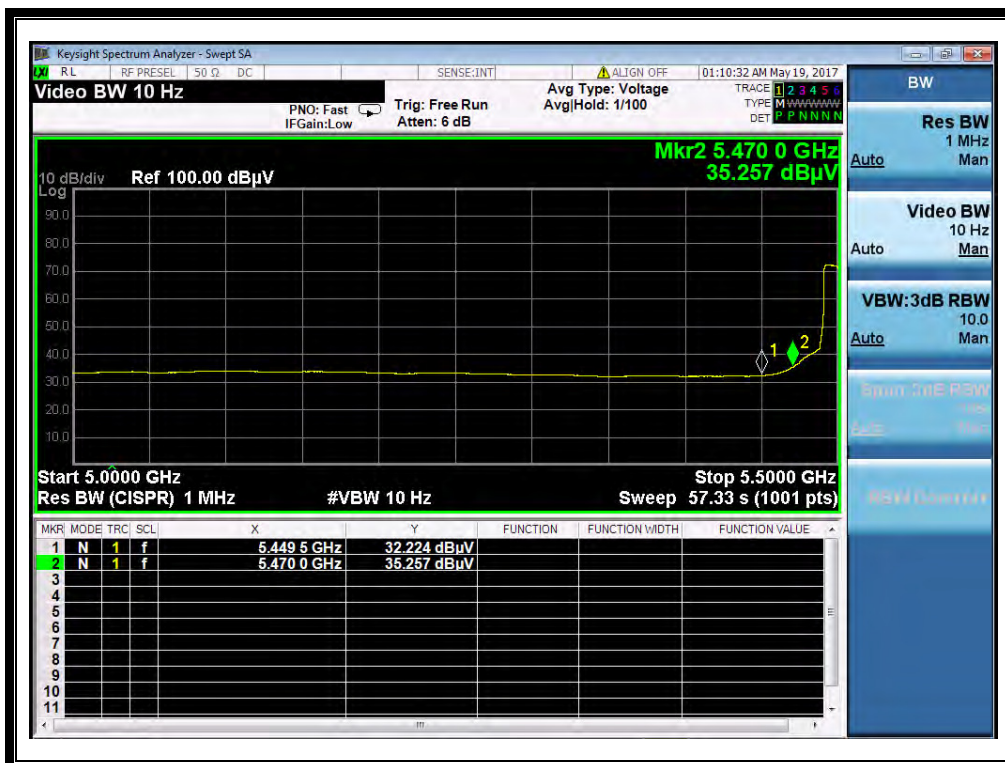

(Channel = 100 AVG @ 802.11ac)

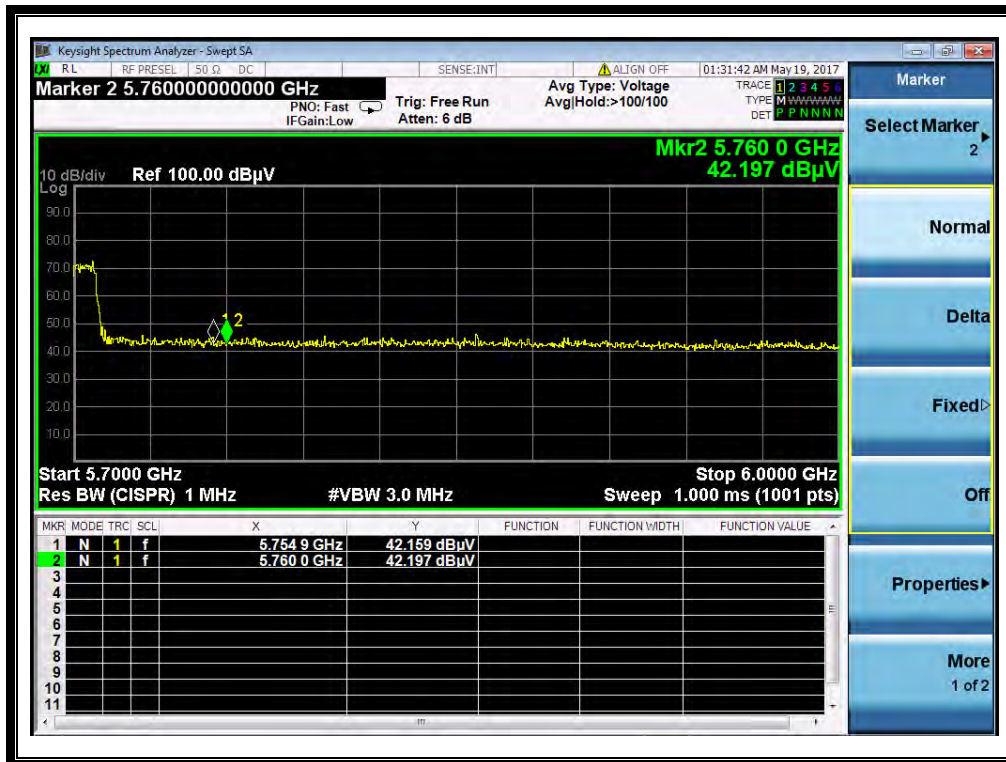

(Channel = 140 PEAK @ 802.11ac)

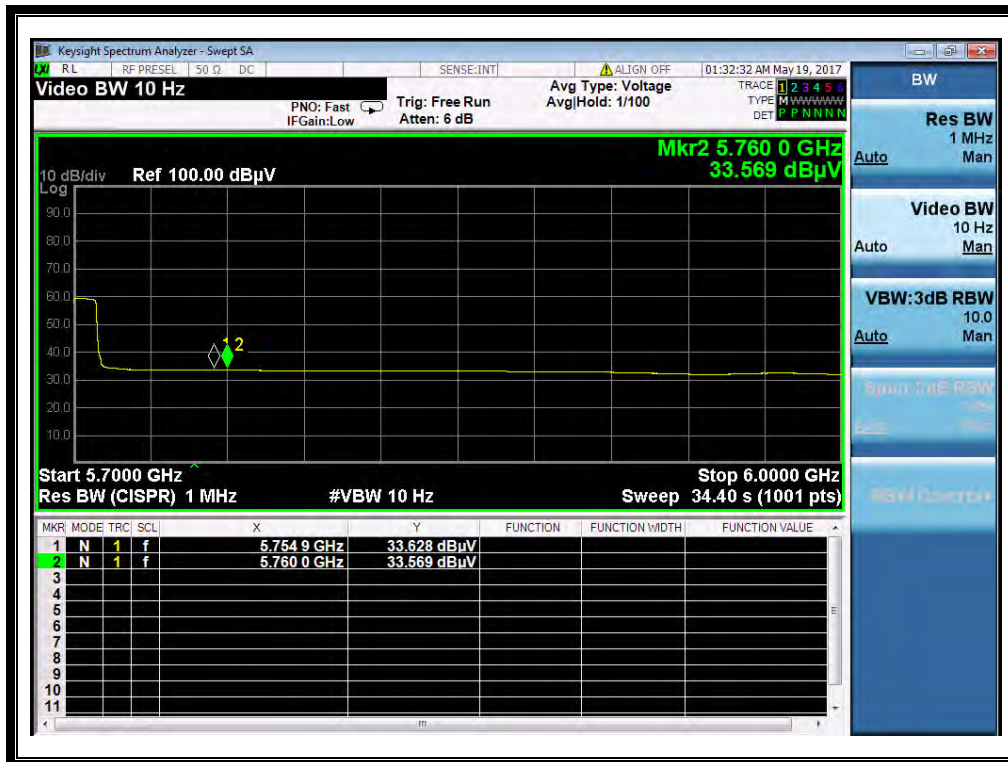

(Channel = 140 AVG @ 802.11ac)



2.5.3.2 802.11ac-40MHz Test mode

The lowest and highest channels are tested to verify the band edge emissions.

A. Test Verdict:

Channel	Frequency (MHz)	Detector	Receiver Reading U _R (dBuV)	A _T (dB)	A _{Factor} (dB@3m)	Max. Emission E (dBμV/m)	Limit (dBμV/m)	Verdict
		PK/ AV						
38	5138.25	PK	44.55	-50.65	32.11	26.01	74	Pass
38	5138.25	AV	34.24	-50.65	32.11	15.70	54	Pass
62	5356.00	PK	42.17	-50.65	32.11	23.63	74	Pass
62	5356.00	AV	32.44	-50.65	32.11	13.90	54	Pass
102	5453.50	PK	41.97	-50.65	32.11	23.43	74	Pass
102	5453.50	AV	32.44	-50.65	32.11	13.90	54	Pass
142	5746.25	PK	44.18	-50.65	32.11	25.64	74	Pass
142	5746.25	AV	34.01	-50.65	32.11	15.47	54	Pass

B. Test Plots:

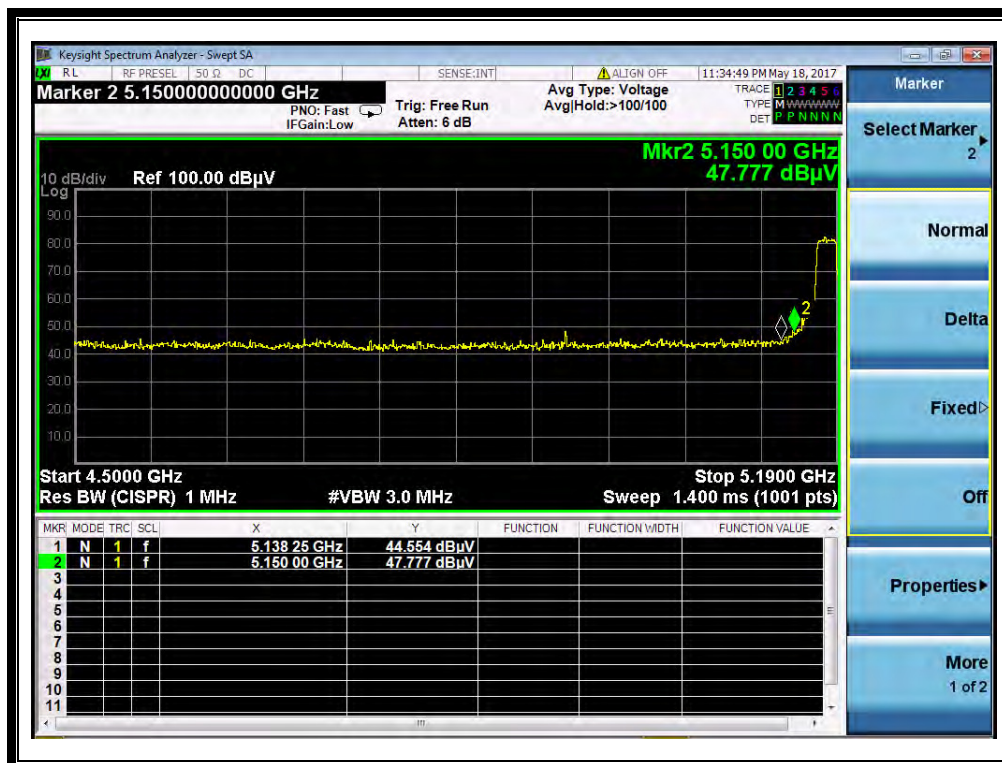

(Channel = 38 PEAK @ 802.11ac)

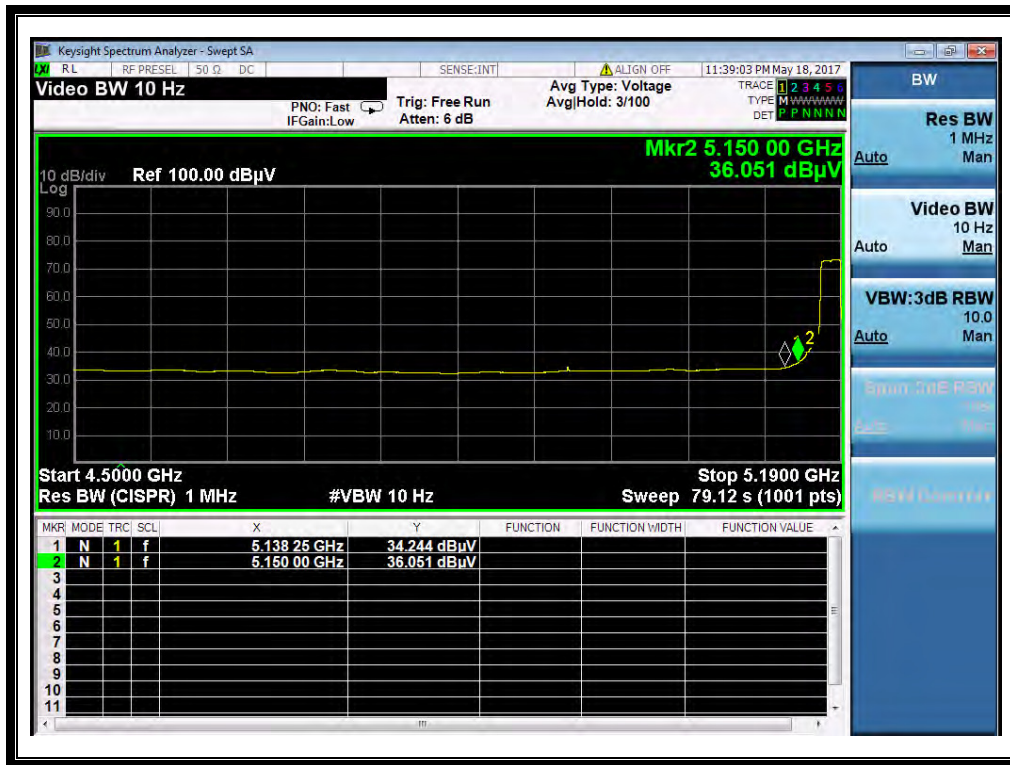

(Channel = 38 AVG @ 802.11ac)

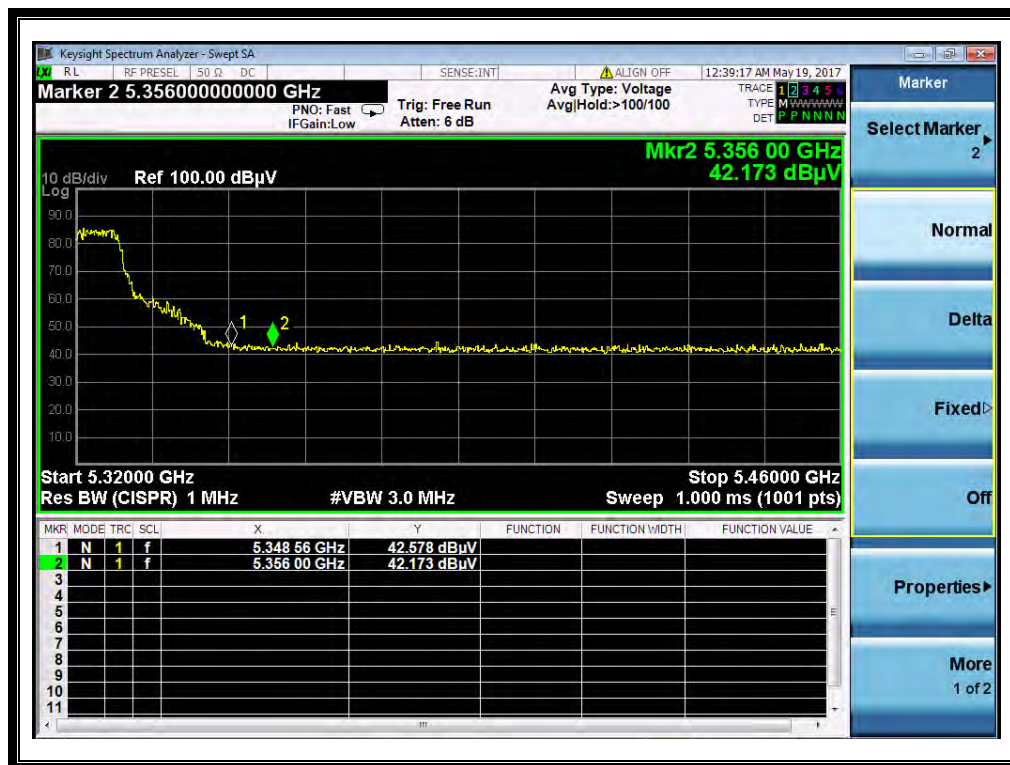

(Channel = 62 PEAK @ 802.11ac)

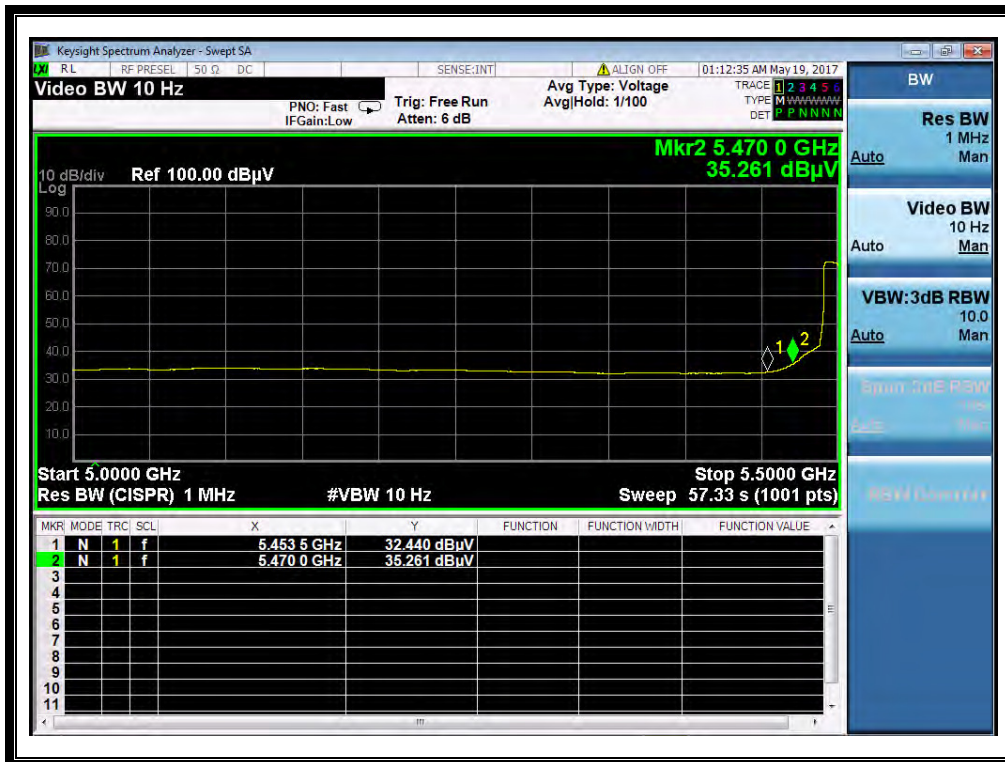

(Channel = 102AVG @ 802.11ac)

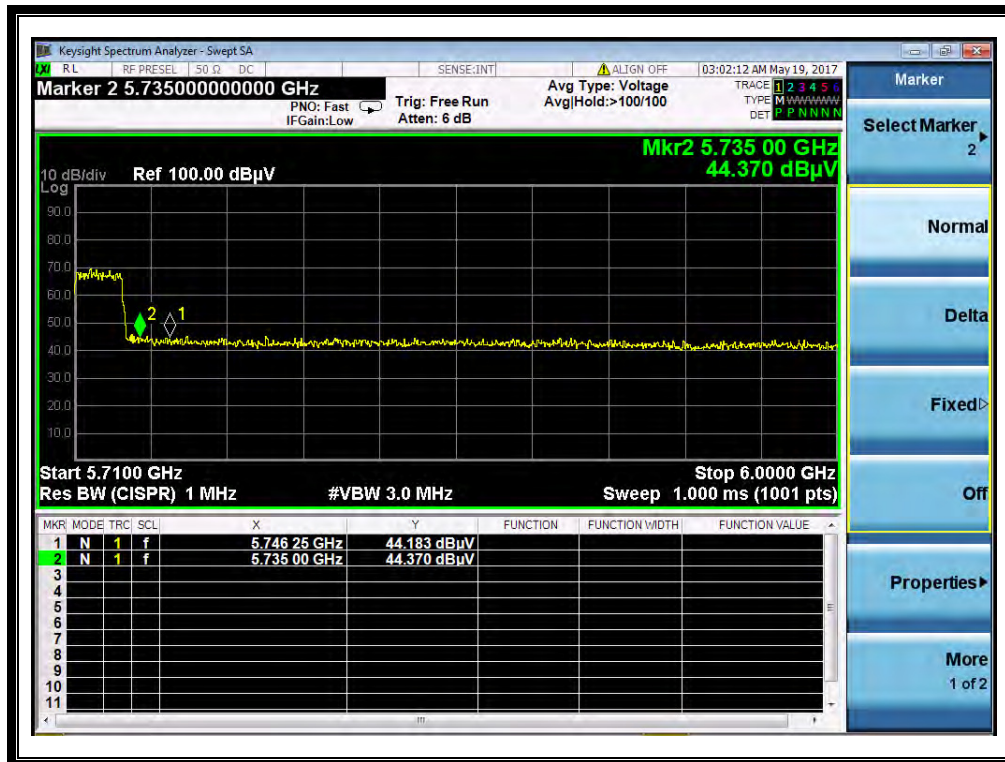

(Channel = 142 PEAK @ 802.11ac)

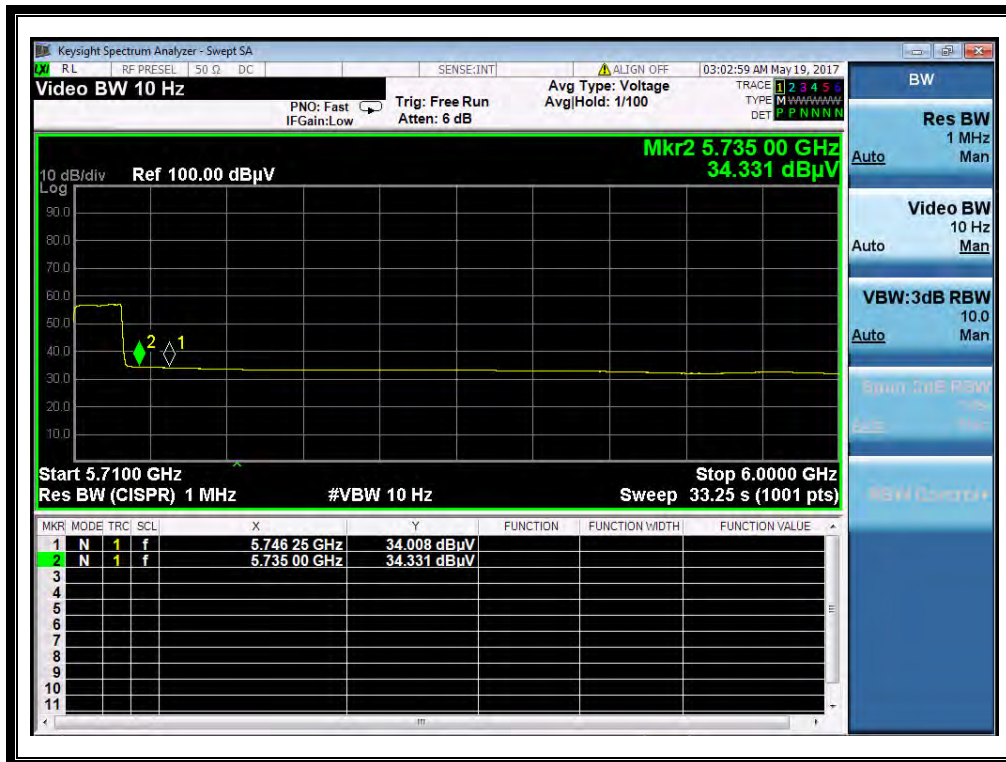

(Channel = 142 AVG @ 802.11ac)

2.5.3.3 802.11ac-80MHz Test mode

The lowest and highest channels are tested to verify the band edge emissions.

A. Test Verdict:

Channel	Frequency (MHz)	Detector	Receiver Reading U_R (dBuV)	A_T (dB)	A_{Factor} (dB@3m)	Max. Emission E (dBμV/m)	Limit (dBμV/m)	Verdict
		PK/ AV						
42	5121.00	PK	43.06	-50.65	32.11	24.52	74	Pass
42	5121.00	AV	33.83	-50.65	32.11	15.29	54	Pass
58	5371.00	PK	41.74	-50.65	32.11	23.20	74	Pass
58	5371.00	AV	32.20	-50.65	32.11	13.66	54	Pass
106	5415.52	PK	42.25	-50.65	32.11	23.71	74	Pass
106	5415.52	AV	32.30	-50.65	32.11	13.76	54	Pass
138	5753.24	PK	42.63	-50.65	32.11	24.09	74	Pass
138	5753.24	AV	33.84	-50.65	32.11	15.30	54	Pass

B. Test Plots:

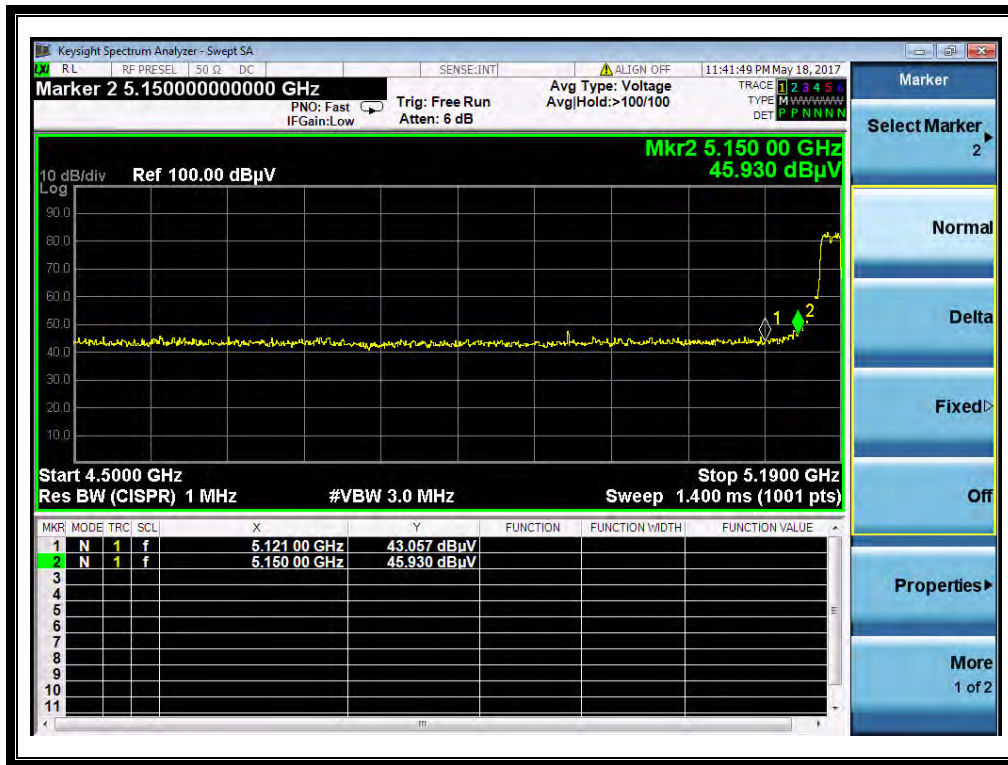

(Channel = 42 PEAK @ 802.11ac)

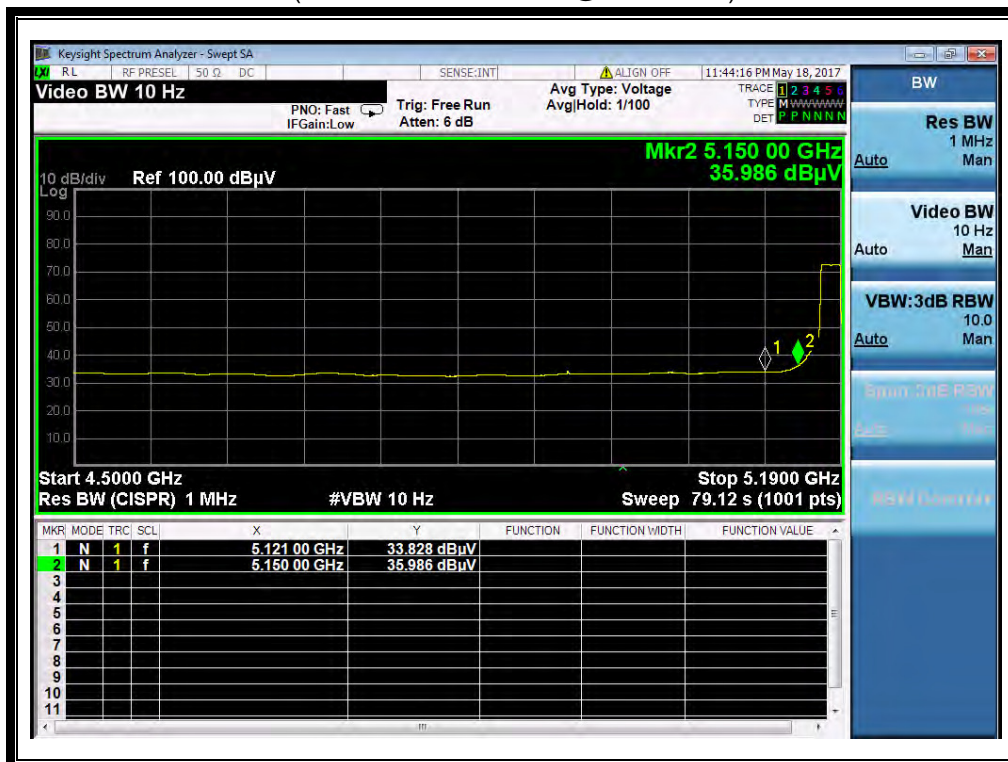

(Channel = 42 AVG @ 802.11ac)

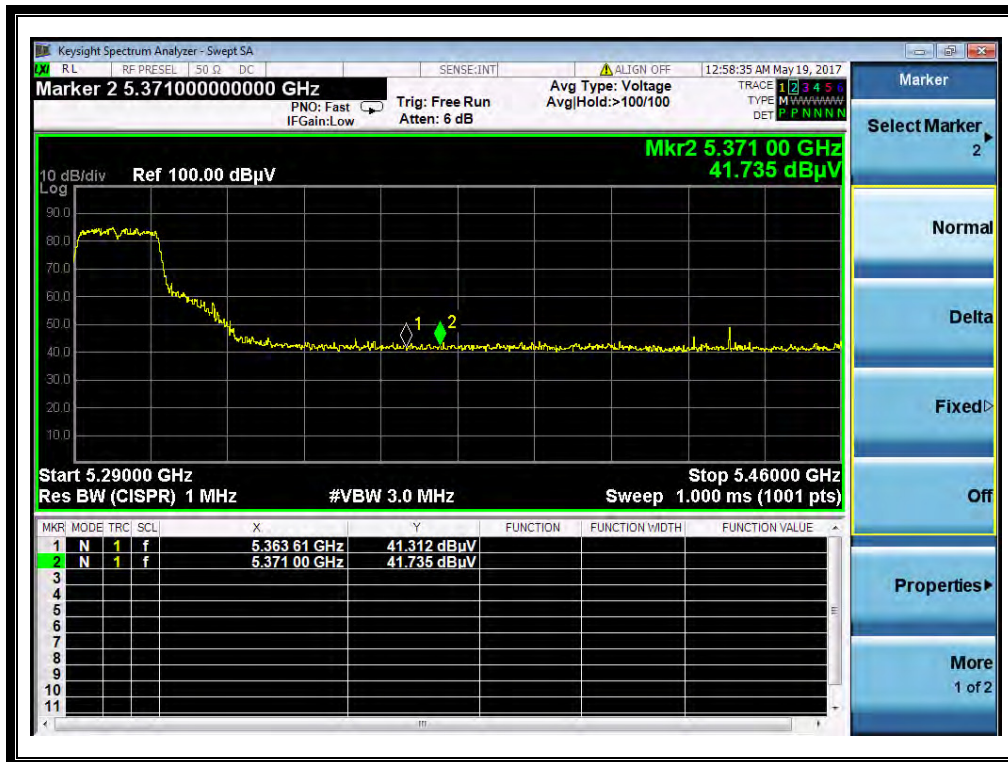

(Channel = 58 PEAK @ 802.11ac)

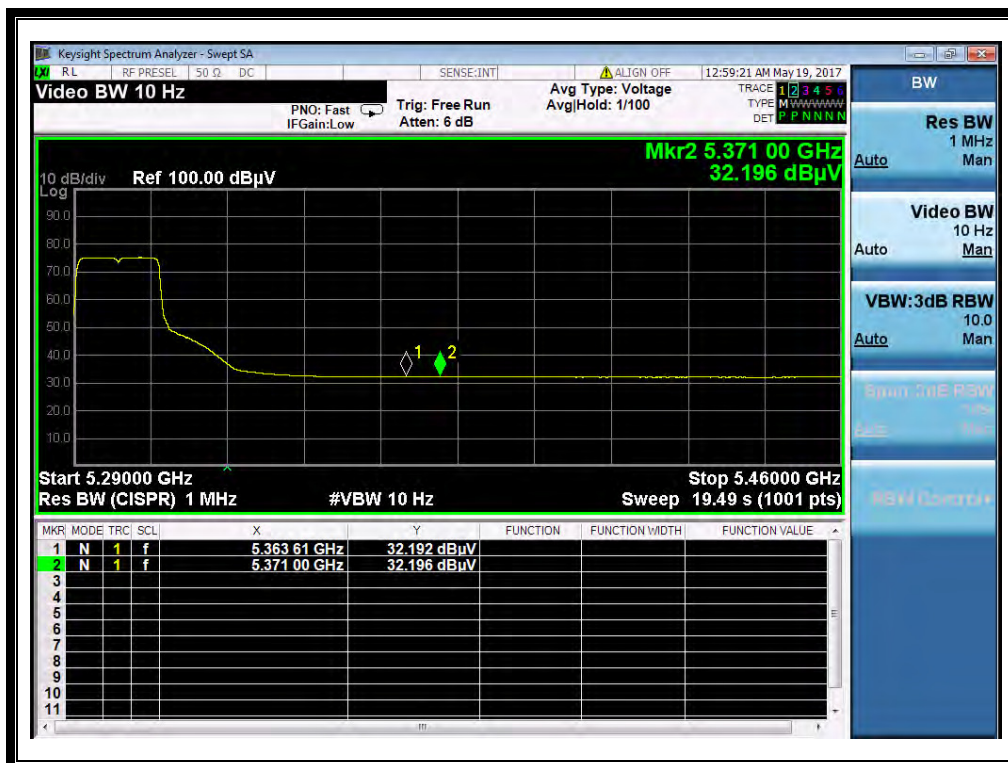

(Channel = 58 PEAK @ 802.11ac)

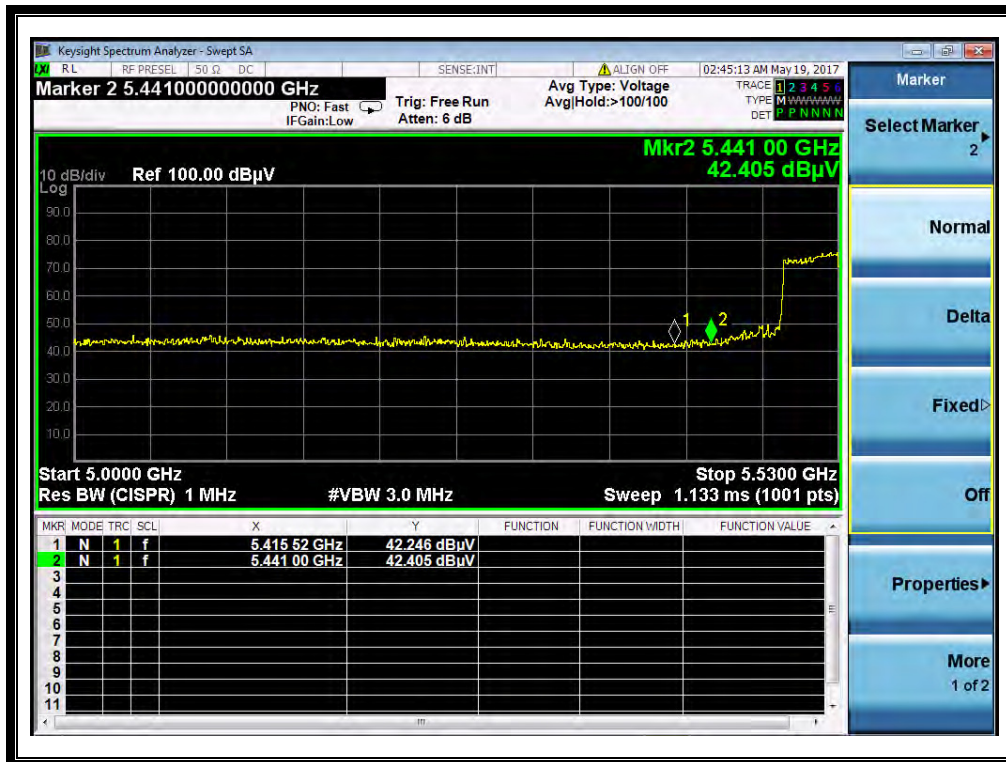

(Channel = 106 PEAK @ 802.11ac)

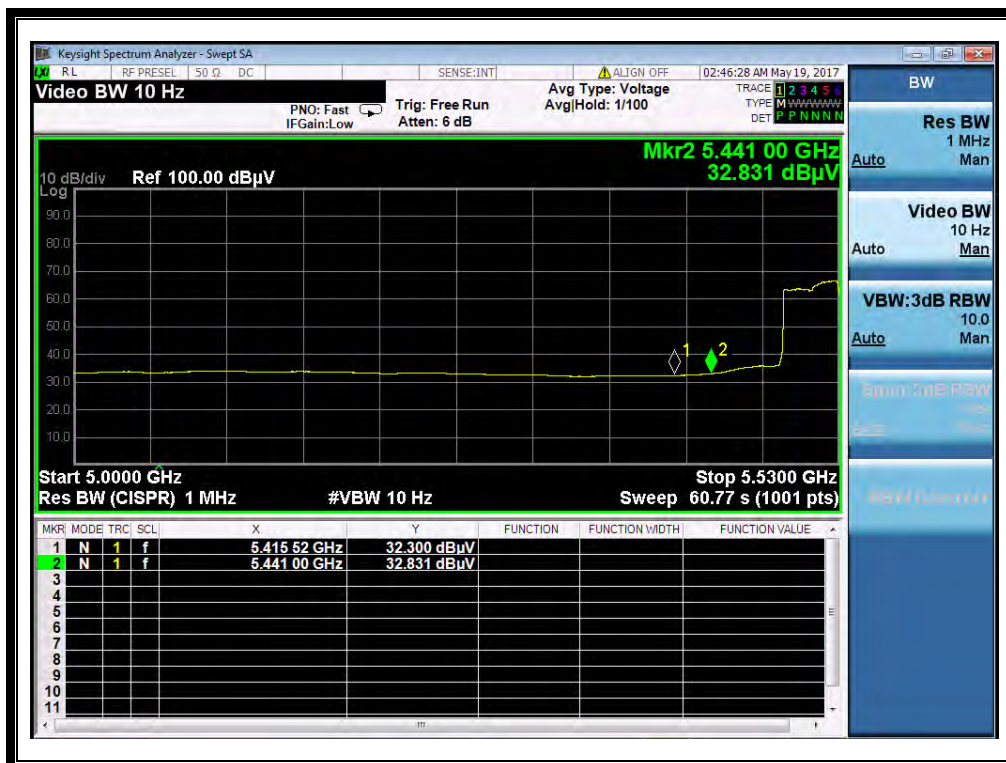

(Channel = 106 PEAK @ 802.11ac)

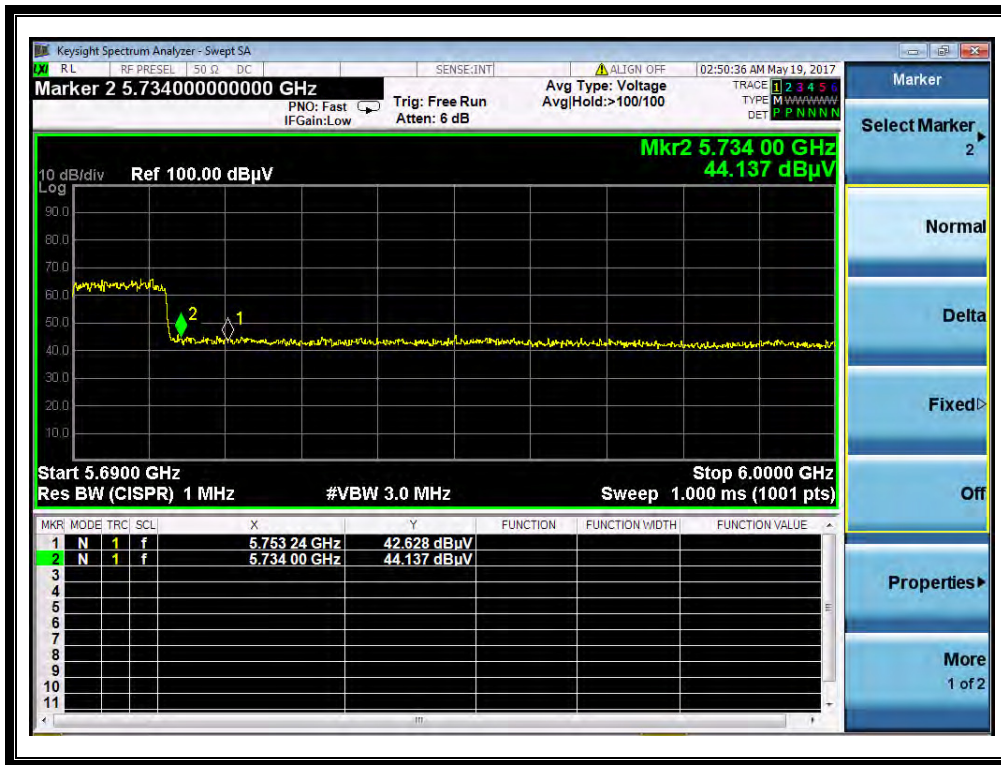

(Channel = 138 PEAK @ 802.11ac)

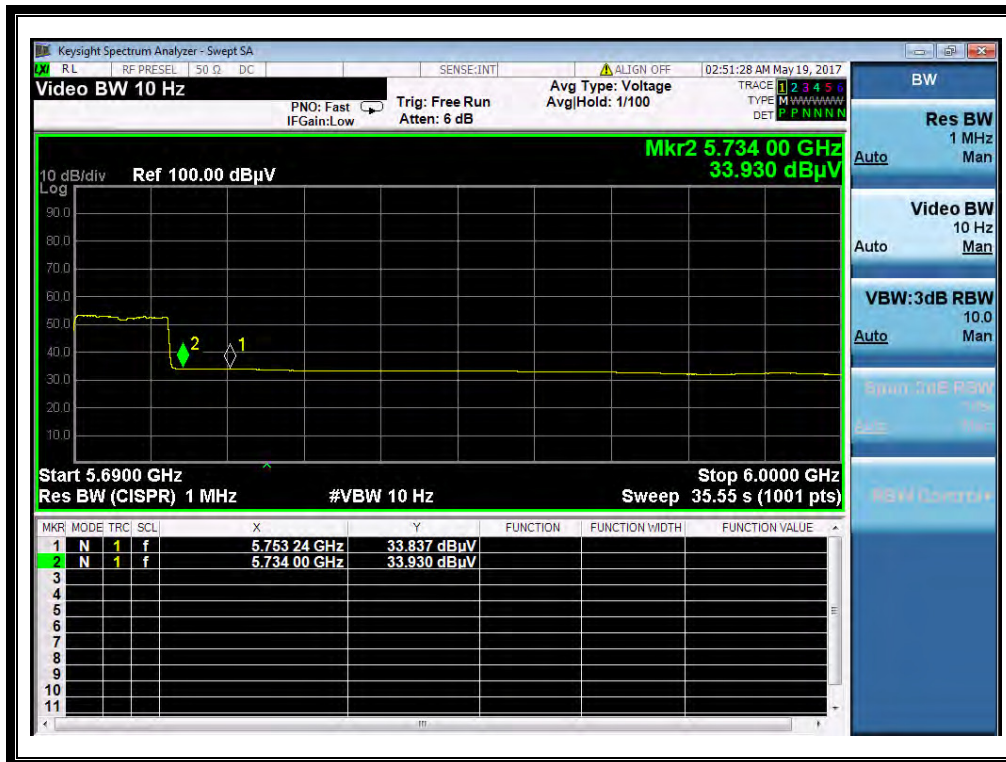

(Channel = 138 PEAK @ 802.11ac)



2.5.3.4 802.11n-20MHz Test mode

The lowest and highest channels are tested to verify the band edge emissions.

A. Test Verdict:

Channel	Frequency (MHz)	Detector	Receiver Reading	A _T (dB)	A _{Factor} (dB@3m)	Max. Emission E (dBμV/m)	Limit (dBμV/m)	Verdict
		PK/ AV	U _R (dBuV)					
36	5119.62	PK	45.67	-50.65	32.11	27.13	74	Pass
36	5119.62	AV	33.82	-50.65	32.11	15.28	54	Pass
64	5354.80	PK	42.37	-50.65	32.11	23.83	74	Pass
64	5354.80	AV	32.41	-50.65	32.11	13.87	54	Pass
100	5447.00	PK	42.35	-50.65	32.11	23.81	74	Pass
100	5447.00	AV	32.14	-50.65	32.11	13.60	54	Pass
140	5760.00	PK	41.15	-50.65	32.11	22.61	74	Pass
140	5760.00	AV	33.60	-50.65	32.11	15.06	54	Pass

B. Test Plots:

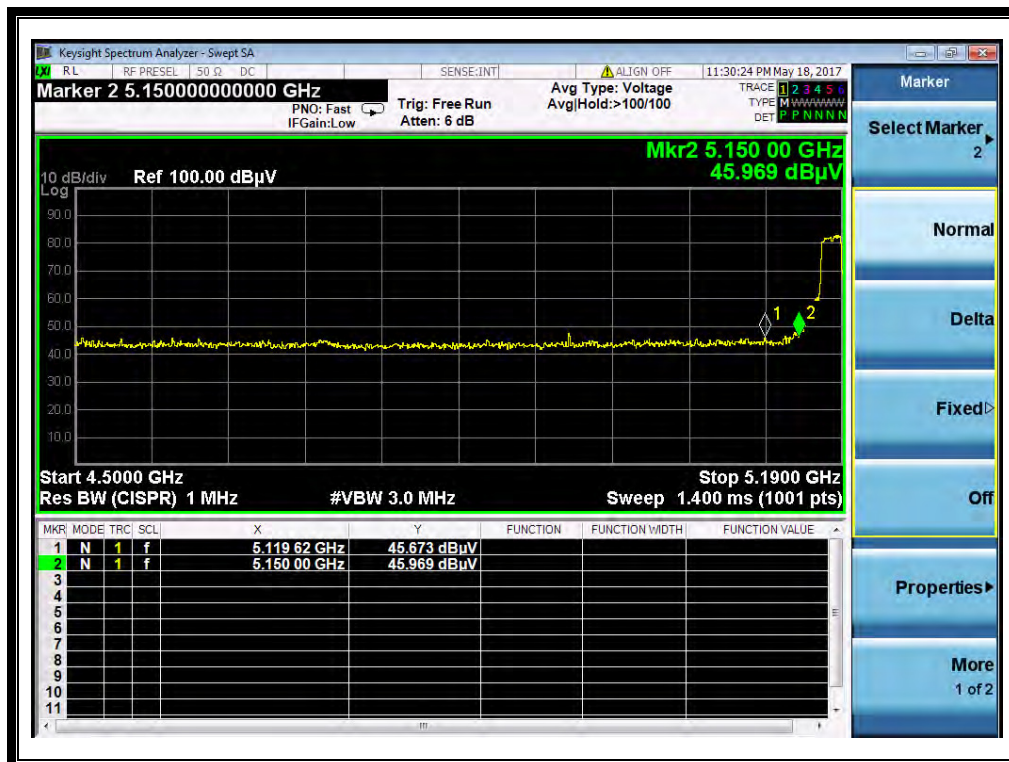

(Channel = 36 PEAK @ 802.11n 20MHz)

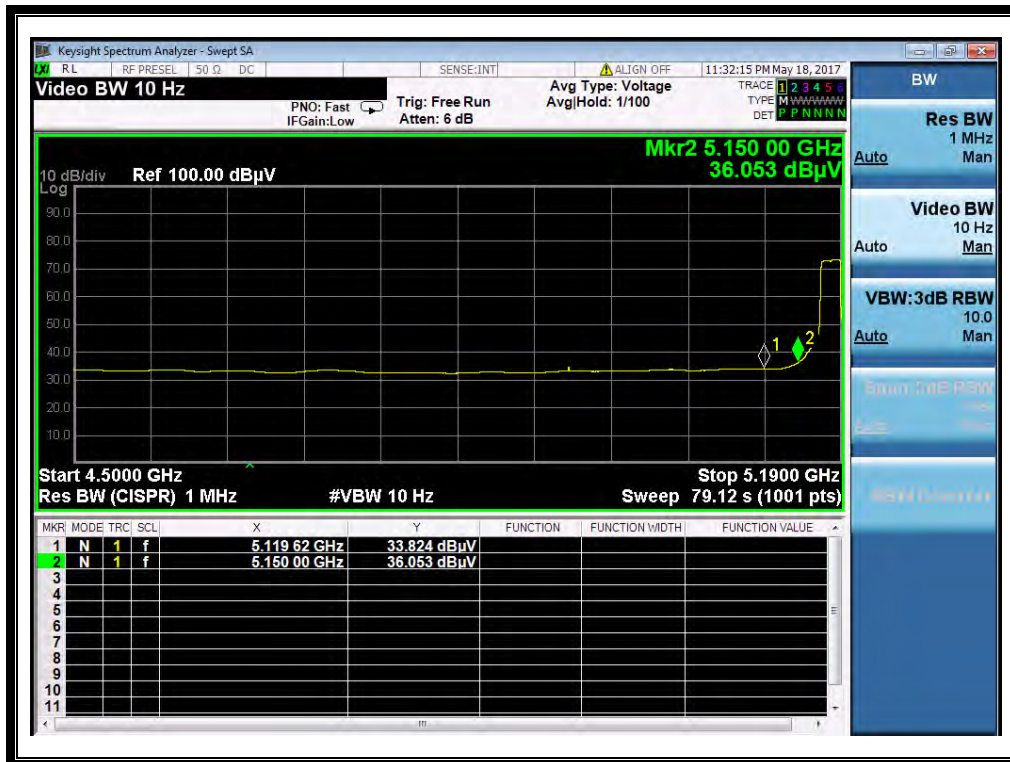

(Channel = 36 AVG @ 802.11n 20MHz)



(Channel = 64 PEAK @ 802.11n 20MHz)

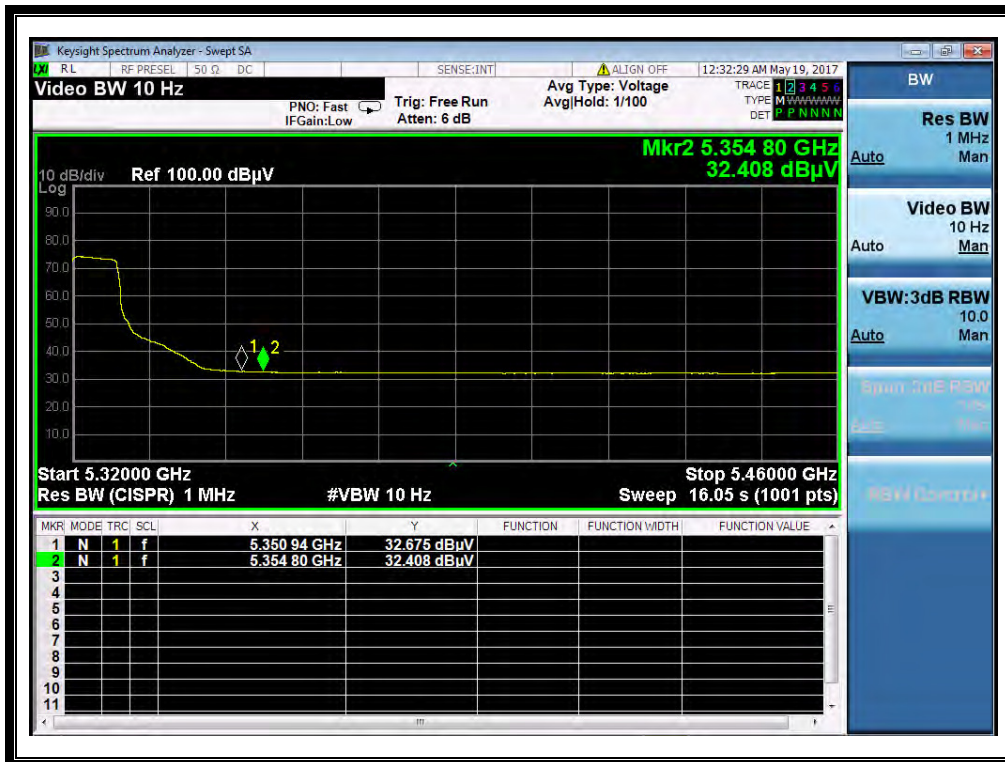

(Channel = 64 AVG @ 802.11n 20MHz)

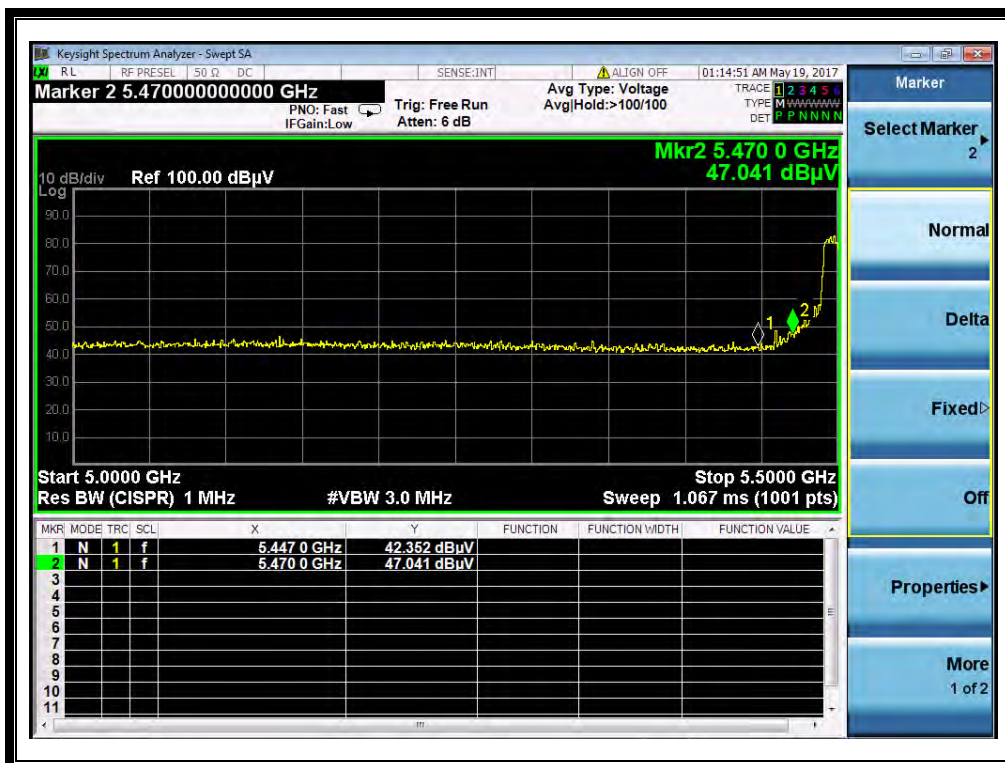

(Channel = 100 PEAK @ 802.11n 20MHz)

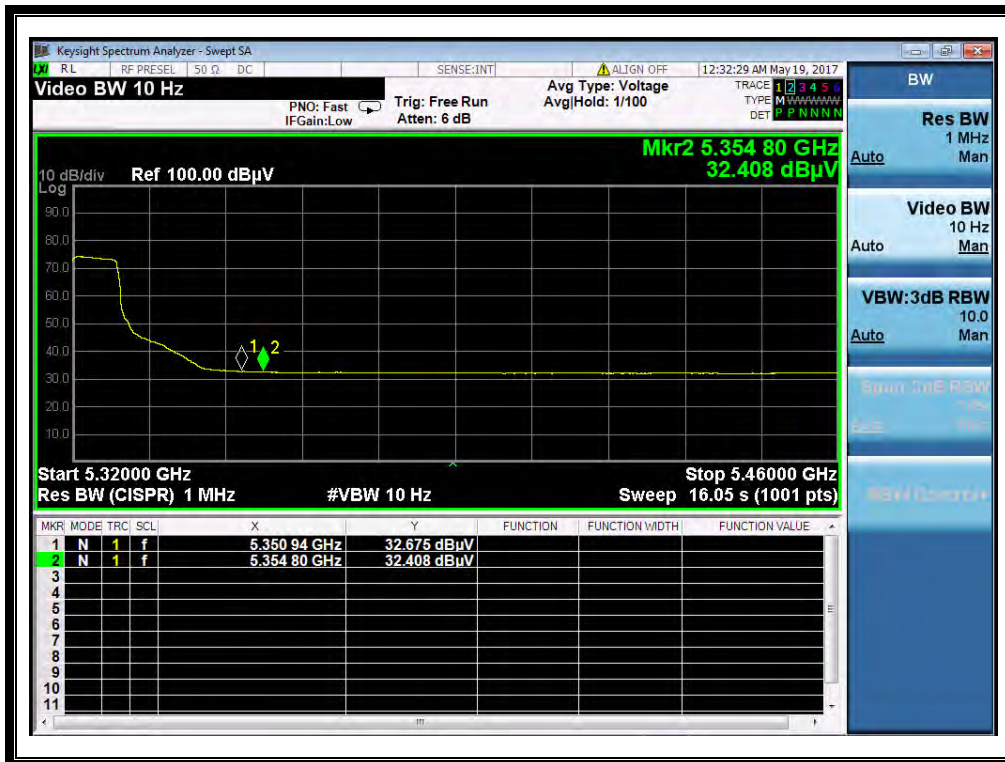

(Channel = 100 AVG @802.11n 20MHz)

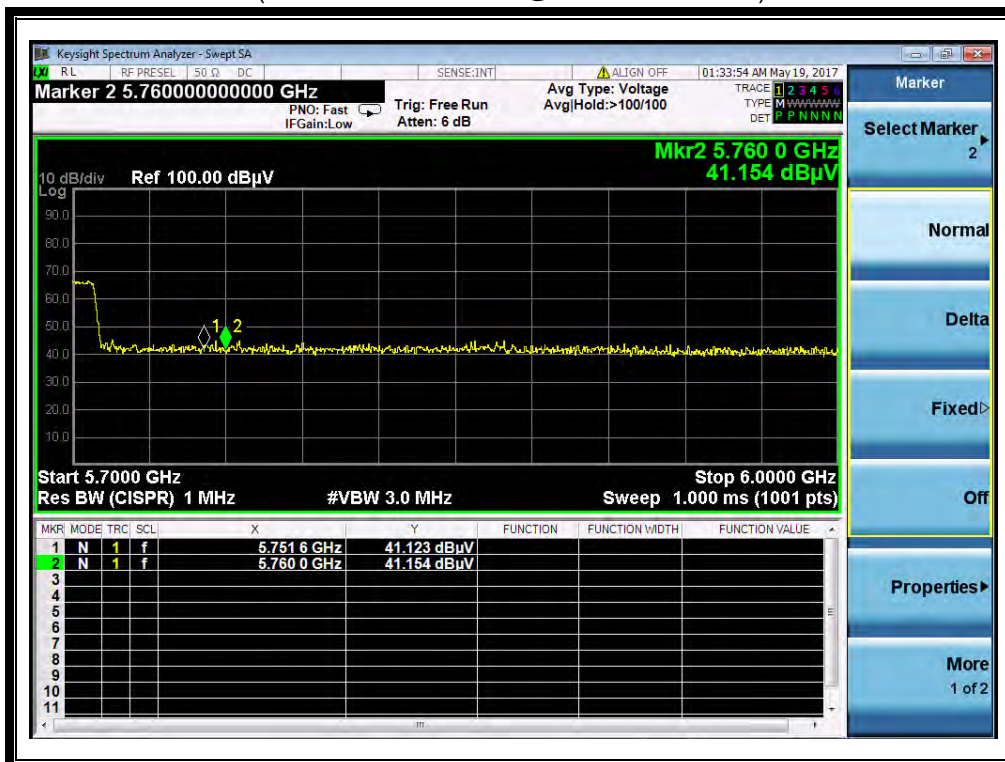

(Channel = 140 PEAK @802.11n 20MHz)

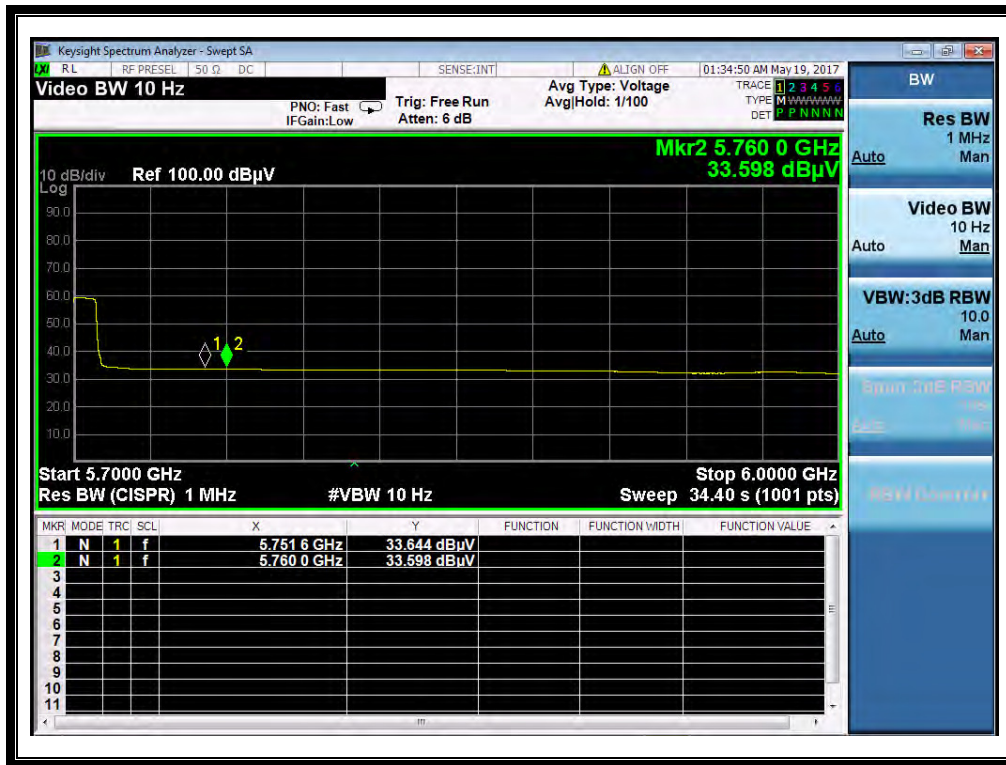

(Channel = 140 AVG @ 802.11n 20MHz)

2.5.3.5 802.11n-40MHz Test mode

The lowest and highest channels are tested to verify the band edge emissions.

A. Test Verdict:

Channel	Frequency (MHz)	Detector	Receiver Reading U_R (dBuV)	A_T (dB)	A_{Factor} (dB@3m)	Max. Emission E (dBuV/m)	Limit (dBuV/m)	Verdict
		PK/ AV						
38	5138.25	PK	44.55	-50.65	32.11	26.01	74	Pass
38	5138.25	AV	34.24	-50.65	32.11	15.70	54	Pass
62	5356.00	PK	42.35	-50.65	32.11	23.81	74	Pass
62	5356.00	AV	32.37	-50.65	32.11	13.83	54	Pass
102	5418.50	PK	42.03	-50.65	32.11	23.49	74	Pass
102	5418.50	AV	31.99	-50.65	32.11	13.45	54	Pass
142	5760.00	PK	43.01	-50.65	32.11	24.47	74	Pass
142	5760.00	AV	33.64	-50.65	32.11	15.10	54	Pass

B. Test Plots:

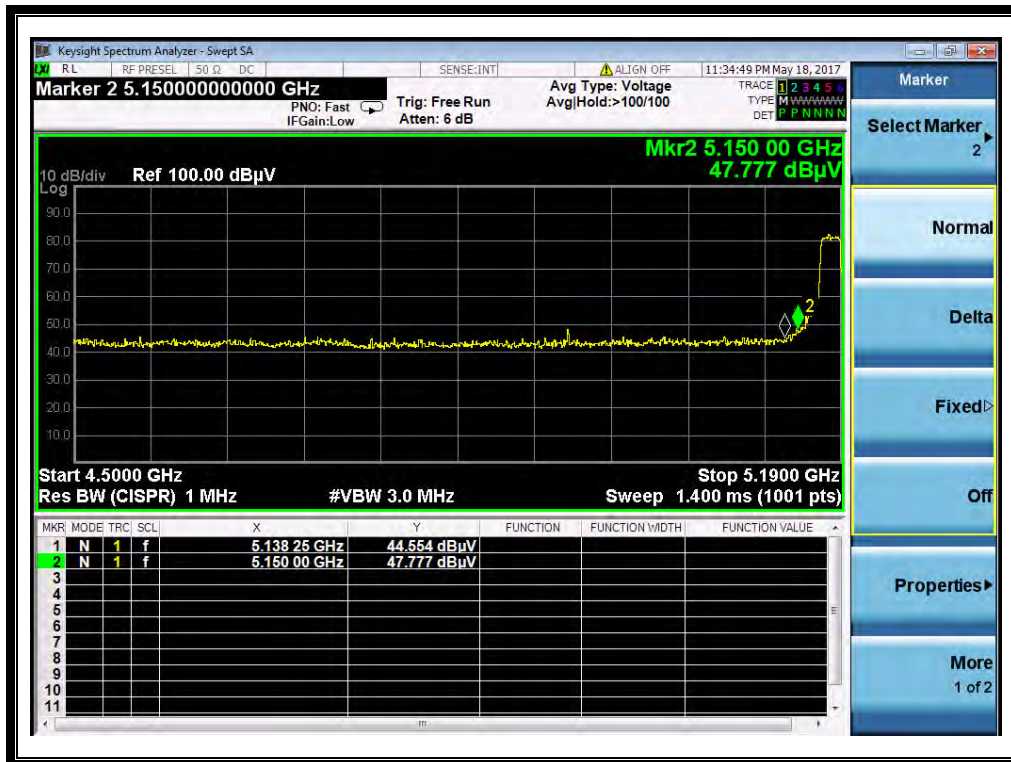

(Channel = 38 PEAK @ 802.11n 40MHz)

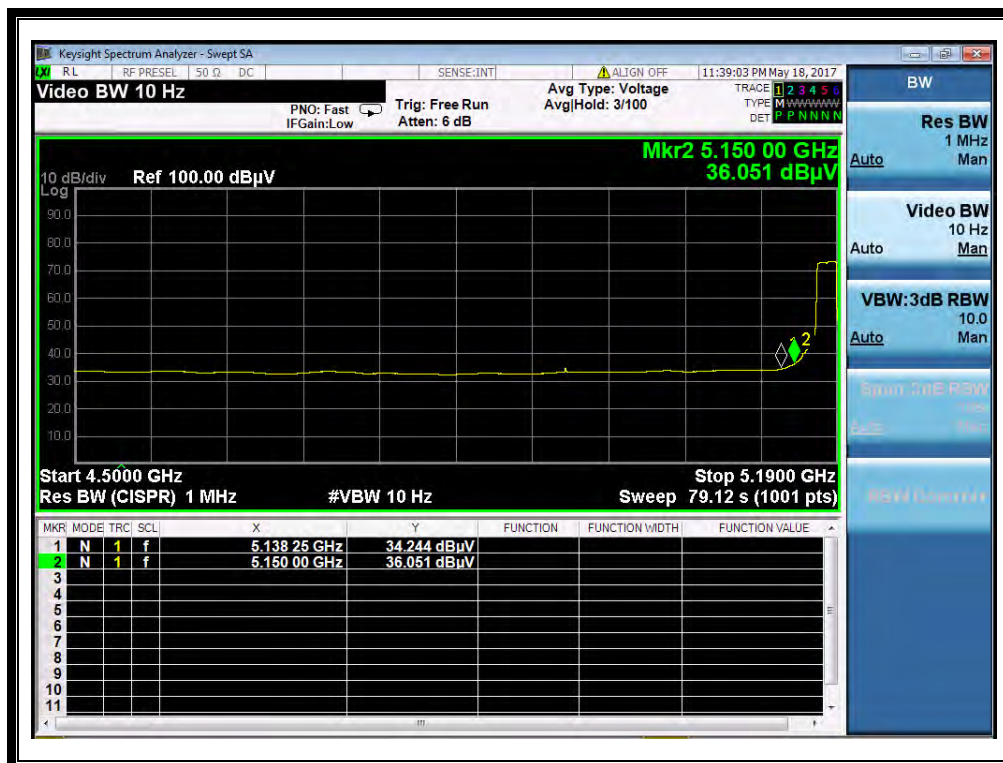

(Channel = 38 AVG @ 802.11n 40MHz)

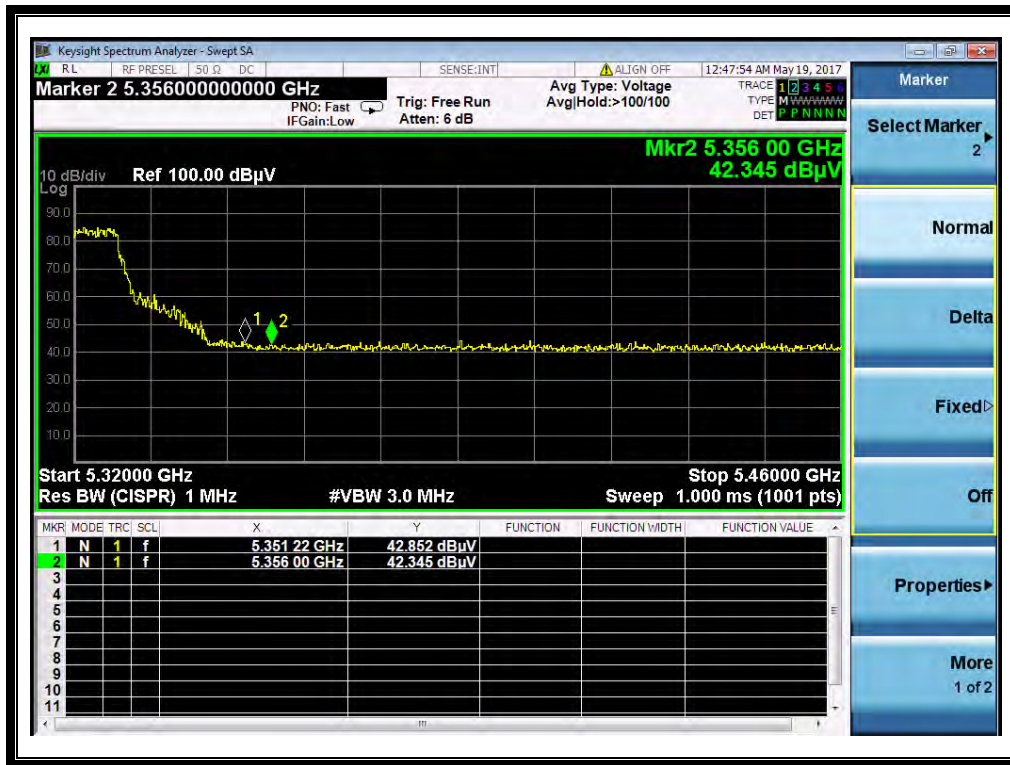

(Channel = 62 PEAK @ 802.11n 40MHz)

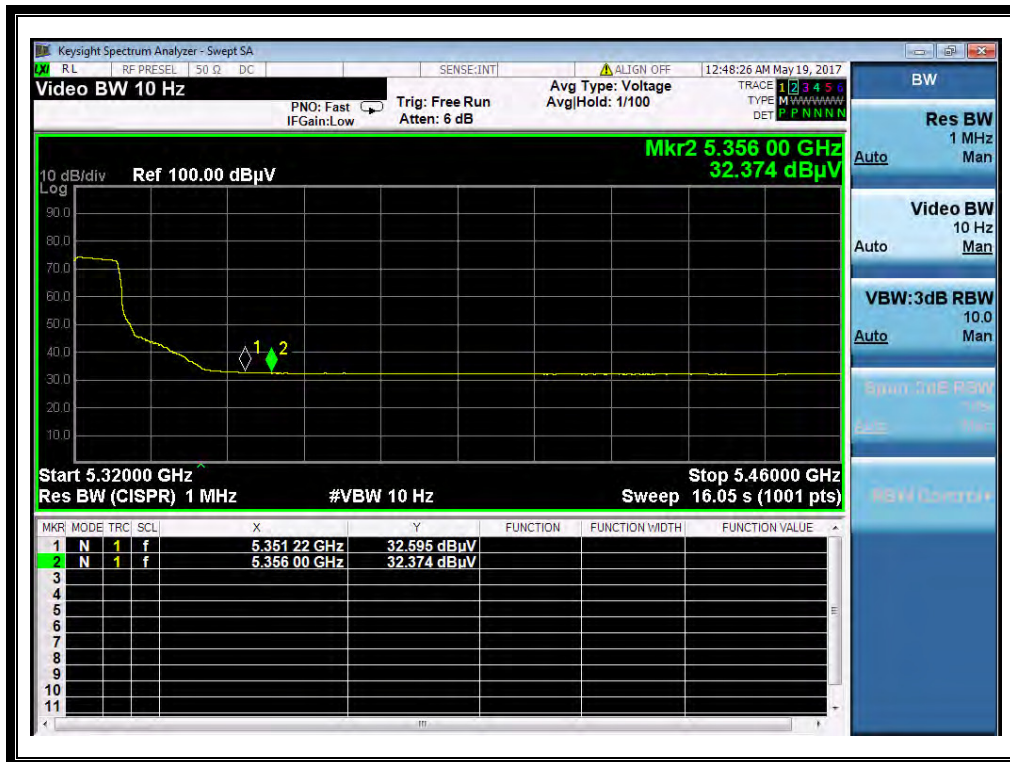

(Channel = 62 AVG @ 802.11n 40MHz)

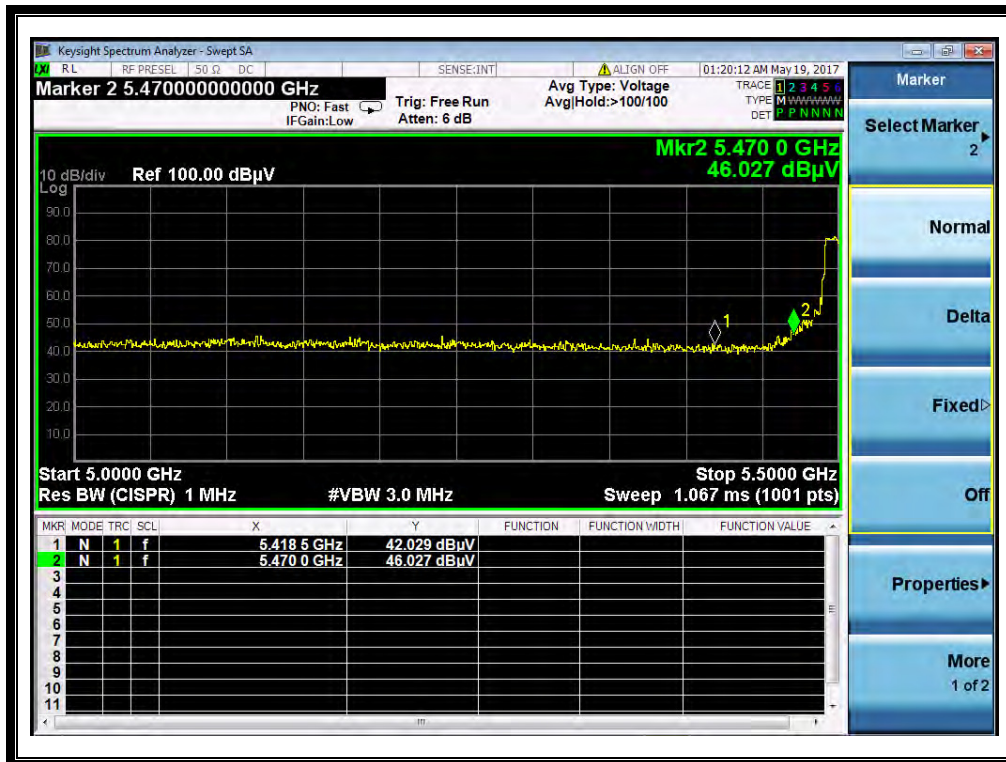

(Channel =102 PEAK @ 802.11n 40MHz)

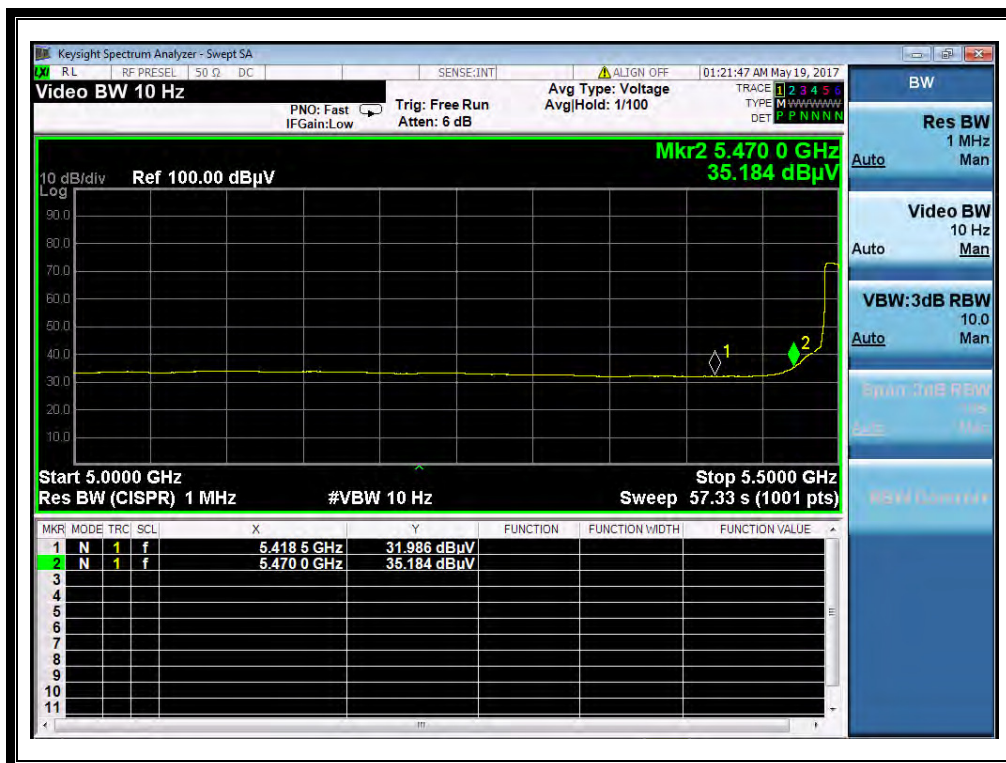

(Channel = 102AVG @ 802.11n 40MHz)

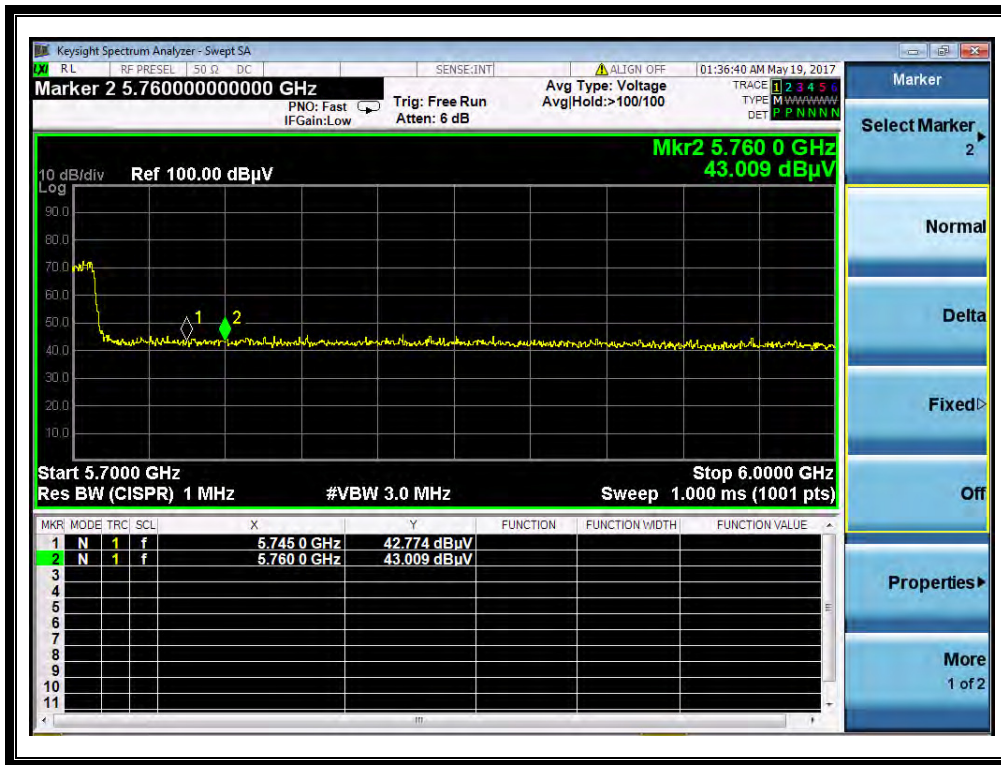

(Channel = 142 PEAK @ 802.11n 40MHz)

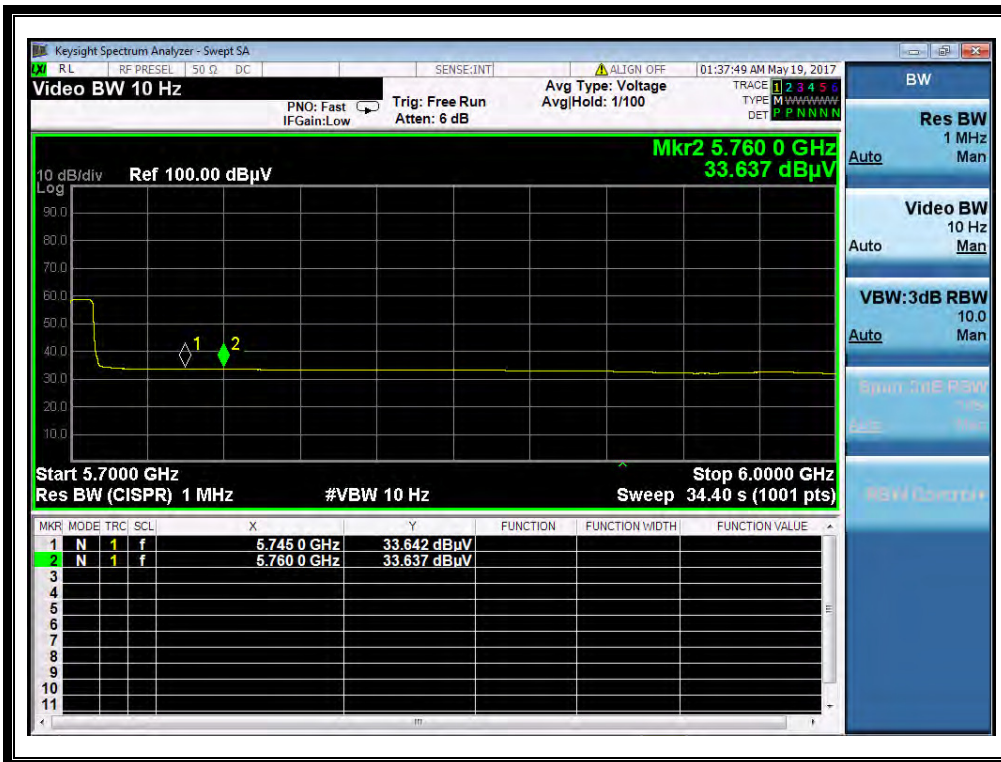

(Channel = 142 AVG @ 802.11n 40MHz)



2.6 Frequency Stability

2.6.1 Requirement

Manufacturers of U-NII devices are responsible for ensuring frequency stability such that an emission is maintained within the band of operation under all conditions of normal operation as specified in the user's manual.

2.6.2 Test Procedure

The EUT was placed inside of an environmental chamber as the temperature in the chamber was varied between -30°C and +50°C. The temperature was incremented by 10° intervals and the unit was allowed to stabilize at each temperature before each measurement. The center frequency of the transmitting channel was evaluated at each temperature and the frequency deviation from the channel's center frequency was recorded. Data for the worst case channel is shown below.

2.6.3 Test Result

Frequency Stability Measurements for UNII Band 1 (Ch. 36)

VOLTAGE (%)	POWER (VDC)	TEMP (°C)	FREQUENCY (Hz)	Freq Dev. (Hz)	Deviation (%)
100%	3.7	+20(Ref)	5,179,999,991	9	0.00000017
100%		-30	5,180,000,011	11	0.00000021
100%		-20	5,180,000,013	13	0.00000025
100%		-10	5,179,999,947	53	0.00000102
100%		0	5,179,999,995	5	0.00000010
100%		+10	5,180,000,031	31	0.00000060
100%		+20	5,179,999,996	4	0.00000008
100%		+30	5,179,999,999	1	0.00000002
100%		+40	5,180,000,015	15	0.00000029
100%		+50	5,180,000,005	5	0.00000010
85%		3.55	+20	5,180,000,011	11
115%	4.35	+20	5,179,999,999	1	0.00000002



Frequency Stability Measurements for UNII Band 2A (Ch. 52)

VOLTAGE (%)	POWER (VDC)	TEMP (°C)	FREQUENCY (Hz)	Freq Dev. (Hz)	Deviation (%)
100%	3.7	+20(Ref)	5,259,999,986	14	0.00000027
100%		-30	5,260,000,011	11	0.00000021
100%		-20	5,260,000,026	26	0.00000049
100%		-10	5,259,999,998	2	0.00000004
100%		0	5,259,999,989	11	0.00000021
100%		+10	5,260,000,016	16	0.00000030
100%		+20	5,260,000,025	25	0.00000048
100%		+30	5,259,999,985	15	0.00000029
100%		+40	5,259,999,986	14	0.00000027
100%		+50	5,260,000,099	99	0.00000188
85%		3.55	+20	5,260,000,022	22
115%	4.35	+20	5,259,999,974	26	0.00000049

Frequency Stability Measurements for UNII Band 2C (Ch. 100)

VOLTAGE (%)	POWER (VDC)	TEMP (°C)	FREQUENCY (Hz)	Freq Dev. (Hz)	Deviation (%)
100%	3.7	+20(Ref)	5,500,000,024	24	0.00000044
100%		-30	5,499,999,994	6	0.00000011
100%		-20	5,500,000,024	24	0.00000044
100%		-10	5,499,999,991	9	0.00000016
100%		0	5,500,000,026	26	0.00000047
100%		+10	5,499,999,986	14	0.00000025
100%		+20	5,500,000,016	16	0.00000029
100%		+30	5,500,000,028	28	0.00000051
100%		+40	5,500,000,026	26	0.00000047
100%		+50	5,499,999,982	18	0.00000033
85%		3.55	+20	5,500,000,015	15
115%	4.35	+20	5,499,999,996	4	0.00000007



Frequency Stability Measurements for UNII Band 3 (Ch. 149)

VOLTAGE (%)	POWER (VDC)	TEMP (°C)	FREQUENCY (Hz)	Freq Dev. (Hz)	Deviation (%)
100%	3.7	+20(Ref)	5,744,999,988	12	0.00000021
100%		-30	5,744,999,995	5	0.00000009
100%		-20	5,745,000,011	11	0.00000019
100%		-10	5,744,999,987	13	0.00000023
100%		0	5,745,000,031	31	0.00000054
100%		+10	5,745,000,021	21	0.00000037
100%		+20	5,745,000,002	2	0.00000003
100%		+30	5,745,000,012	12	0.00000021
100%		+40	5,744,999,996	4	0.00000007
100%		+50	5,745,000,011	11	0.00000019
85%		3.55	+20	5,745,000,017	17
115%	4.35	+20	5,744,999,988	12	0.00000021

Note: Based on the results of the frequency stability test shown above the frequency deviation results measured are very small. As such it is determined that the channels at the band edge would remain in-band when the maximum measured frequency deviation noted during the frequency stability tests is applied. Therefore the device is determined to remain operating in band over the temperature and voltage range as tested.



2.7 Transmit Power Control (TPC) and Dynamic Frequency Selection (DFS)

2.7.1 Requirement

According to FCC section 15.407(h), (1) Transmit power control (TPC). U-NII devices operating in the 5.25-5.35 GHz band and the 5.47-5.725 GHz band shall employ a TPC mechanism. The U-NII device is required to have the capability to operate at least 6 dB below the mean EIRP value of 30 dBm. A TPC mechanism is not required for systems with an e.i.r.p. of less than 500 mW.

(2) Radar Detection Function of Dynamic Frequency Selection (DFS). U-NII devices operating with any part of its 26 dB emission bandwidth in the 5.25-5.35 GHz and 5.47-5.725 GHz bands shall employ a DFS radar detection mechanism to detect the presence of radar systems and to avoid co-channel operation with radar systems. Operators shall only use equipment with a DFS mechanism that is turned on when operating in these bands. The device must sense for radar signals at 100 percent of its emission bandwidth. The minimum DFS detection threshold for devices with a maximum e.i.r.p. of 200 mW to 1 W is -64 dBm. For devices that operate with less than 200 mW e.i.r.p. and a power spectral density of less than 10 dBm in a 1 MHz band, the minimum detection threshold is -62 dBm. The detection threshold is the received power averaged over 1 microsecond referenced to a 0 dBi antenna. For the initial channel setting, the manufacturers shall be permitted to provide for either random channel selection or manual channel selection.

A U-NII network will employ a DFS function to detect signals from radar systems and to avoid co-channel operation with these systems. This applies to the 5250-5350 MHz and/or 5470-5725 MHz bands.¹

Within the context of the operation of the DFS function, a U-NII device will operate in either Master Mode or Client Mode. U-NII devices operating in Client Mode can only operate in a network controlled by a U-NII device operating in Master Mode.²

Tables 1 and 2 shown below summarize the information contained in sections 5.1.1 and 5.1.2.

Table 1: Applicability of DFS Requirements Prior to Use of a Channel

Requirement	Operational Mode		
	Master	Client Without Radar Detection	Client With Radar Detection
Non-Occupancy Period	Yes	Not required	Yes
DFS Detection Threshold	Yes	Not required	Yes
Channel Availability Check Time	Yes	Not required	Not required
U-NII Detection Bandwidth	Yes	Not required	Yes



Table 2: Applicability of DFS requirements during normal operation

Requirement	Operational Mode	
	Master	Client Without Radar Detection
DFS Detection Threshold	Yes	Not required
Channel Closing Transmission Time	Yes	Yes
Channel Move Time	Yes	Yes
U-NII Detection Bandwidth	Yes	Not required

Additional requirements for devices with multiple bandwidth modes	Master Device or Client with Radar Detection	Client Without Radar Detection
U-NII Detection Bandwidth and Statistical Performance Check	All BW modes must be tested	Not required
Channel Move Time and Channel Closing Transmission Time	Test using widest BW mode available	Test using the widest BW mode available for the link
All other tests	Any single BW mode	Not required

Note: Frequencies selected for statistical performance check (Section 7.8.4) should include several frequencies within the radar detection bandwidth and frequencies near the edge of the radar detection bandwidth. For 802.11 devices it is suggested to select frequencies in each of the bonded 20 MHz channels and the channel center frequency.

The operational behavior and individual DFS requirements that are associated with these modes are as follows:

2.7.1.1 Master Devices

- a) The Master Device will use DFS in order to detect Radar Waveforms with received signal strength above the DFS Detection Threshold in the 5250 – 5350 MHz and 5470 – 5725 MHz bands. DFS is not required in the 5150 – 5250 MHz or 5725 – 5825 MHz bands.
- b) Before initiating a network on a Channel, the Master Device will perform a Channel Availability Check for a specified time duration (Channel Availability Check Time) to ensure that there is no radar system operating on the Channel, using DFS described under subsection a) above.
- c) The Master Device initiates a U-NII network by transmitting control signals that will enable other U-NII devices to Associate with the Master Device.
- d) During normal operation, the Master Device will monitor the Channel (In-Service Monitoring) to ensure that there is no radar system operating on the Channel, using DFS described under a).
- e) If the Master Device has detected a Radar Waveform during In-Service Monitoring as described under d), the Operating Channel of the U-NII network is no longer an Available Channel. The Master Device will instruct all associated Client Device(s) to stop transmitting on this Channel within the Channel Move Time. The transmissions during the Channel Move Time will be limited to



the Channel Closing Transmission Time.

f) Once the Master Device has detected a Radar Waveform it will not utilize the Channel for the duration of the Non-Occupancy Period. 3

g) If the Master Device delegates the In-Service Monitoring to a Client Device, then the combination will be tested to the requirements described under d) through f) above.

2.7.1.2 Client Devices

a) A Client Device will not transmit before having received appropriate control signals from a Master Device.

b) A Client Device will stop all its transmissions whenever instructed by a Master Device to which it is associated and will meet the Channel Move Time and Channel Closing Transmission Time requirements. The Client Device will not resume any transmissions until it has again received control signals from a Master Device.

c) If a Client Device is performing In-Service Monitoring and detects a Radar Waveform above the DFS Detection Threshold, it will inform the Master Device. This is equivalent to the Master Device detecting the Radar Waveform and d) through f) of section 5.1.1 apply.

d) Irrespective of Client Device or Master Device detection the Channel Move Time and Channel Closing Transmission Time requirements remain the same.

e) The client test frequency must be monitored to ensure no transmission of any type has occurred for 30 minutes. Note: If the client moves with the master, the device is considered compliant if nothing appears in the client non-occupancy period test. For devices that shut down (rather than moving channels), no beacons should appear.

2.7.1.3 DFS Detection Thresholds

Table 3 below provides the DFS Detection Thresholds for Master Devices as well as Client Devices incorporating In-Service Monitoring.

Table 3: DFS Detection Thresholds for Master Devices and Client Devices With Radar Detection

Maximum Transmit Power	Value (See Notes 1, 2, and 3)
EIRP \geq 200 milliwatt	-64 dBm
EIRP < 200 milliwatt and power spectral density < 10 dBm/MHz	-62 dBm
EIRP < 200 milliwatt that do not meet the power spectral density requirement	-64 dBm

Note 1: This is the level at the input of the receiver assuming a 0 dBi receive antenna.

Note 2: Throughout these test procedures an additional 1 dB has been added to the amplitude of the test transmission waveforms to account for variations in measurement equipment. This will ensure that the test signal is at or above the detection threshold level to trigger a DFS response.

Note3: EIRP is based on the highest antenna gain. For MIMO devices refer to KDB Publication 662911 D01.

2.7.1.4 Response Requirements

Table 4 provides the response requirements for Master and Client Devices incorporating DFS.

Table 4: DFS Response Requirement Values

Parameter	Value
Non-occupancy period	Minimum 30 minutes
Channel Availability Check Time	60 seconds
Channel Move Time	10 seconds See Note 1.
Channel Closing Transmission Time	200 milliseconds + an aggregate of 60 milliseconds over remaining 10 second period. See Notes 1 and 2.
U-NII Detection Bandwidth	Minimum 100% of the U-NII 99% transmission power bandwidth. See Note 3.

Note 1: Channel Move Time and the Channel Closing Transmission Time should be performed with Radar Type 0. The measurement timing begins at the end of the Radar Type 0 burst.

Note 2: The Channel Closing Transmission Time is comprised of 200 milliseconds starting at the beginning of the Channel Move Time plus any additional intermittent control signals required to facilitate a Channel move (an aggregate of 60 milliseconds) during the remainder of the 10 second period. The aggregate duration of control signals will not count quiet periods in between transmissions.

Note 3: During the U-NII Detection Bandwidth detection test, radar type 0 should be used. For each frequency step the minimum percentage of detection is 90 percent. Measurements are performed with no data traffic.

2.7.2 Test Description

Section 7.2 of KDB 905462 D02 V01R01

B. Test Setup:

B.1 Setup for Master with injection at the Master

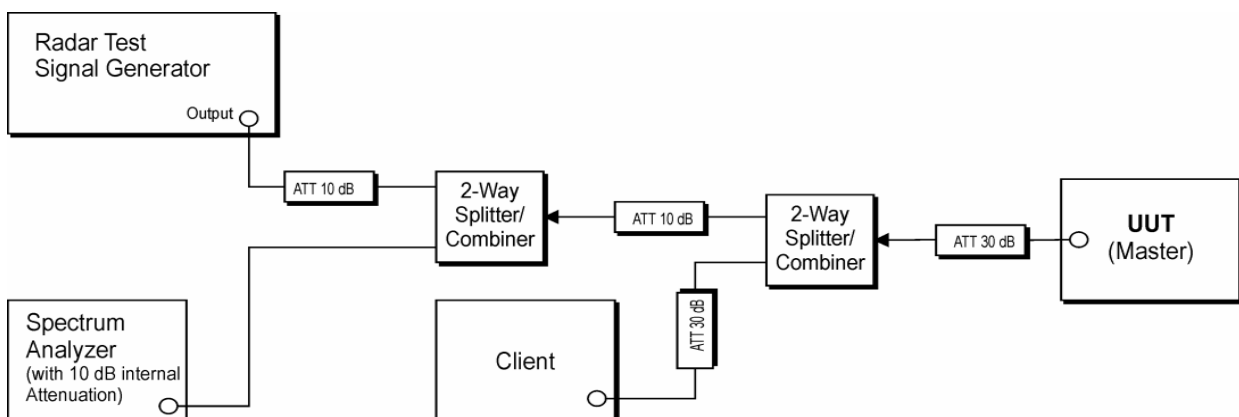

Figure 2: Example Conducted Setup where UUT is a Master and Radar Test Waveforms are injected into the Master

B.2 Setup for Client with injection at the Master

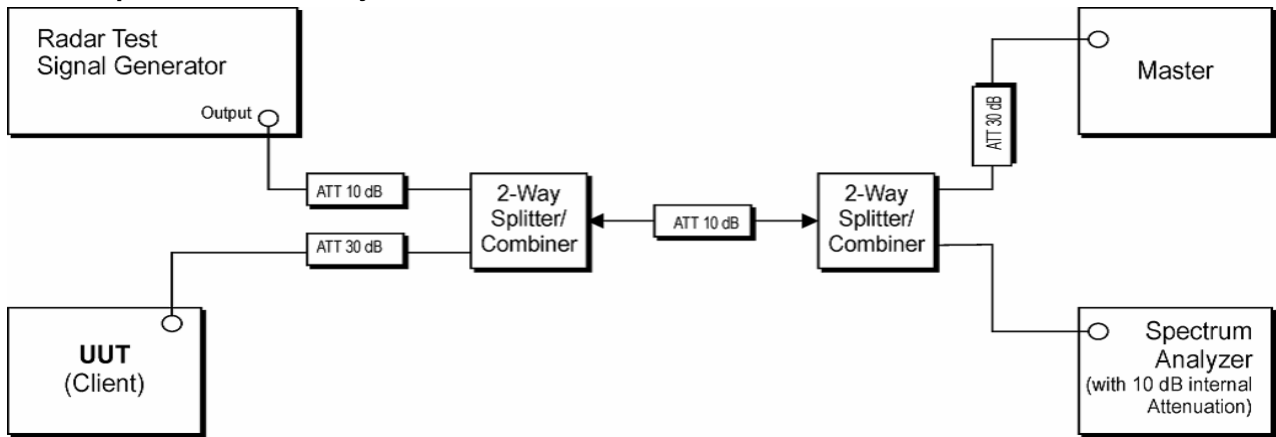

Figure 3: Example Conducted Setup where UUT is a Client and Radar Test Waveforms are injected into the Master

B.3 Setup for Client with injection at the Client

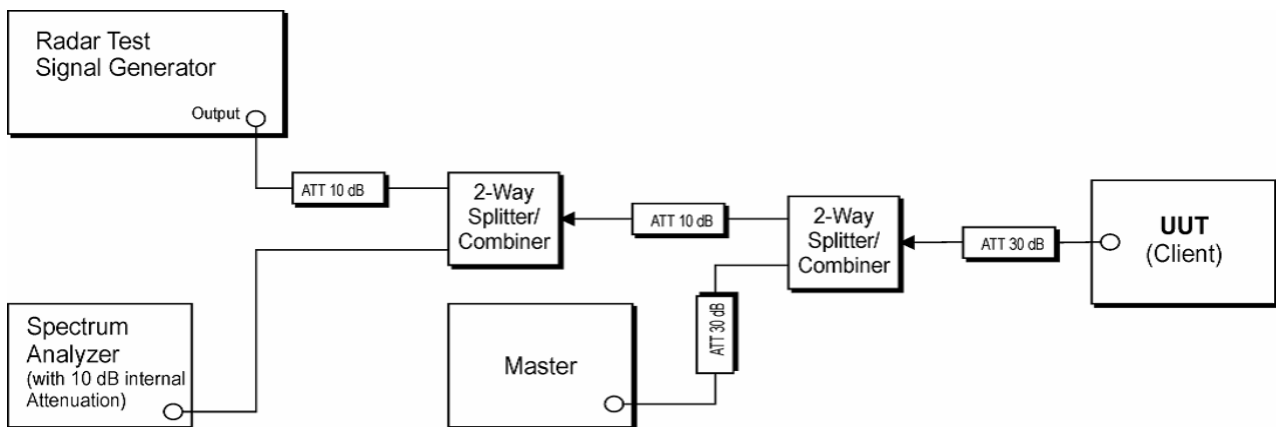
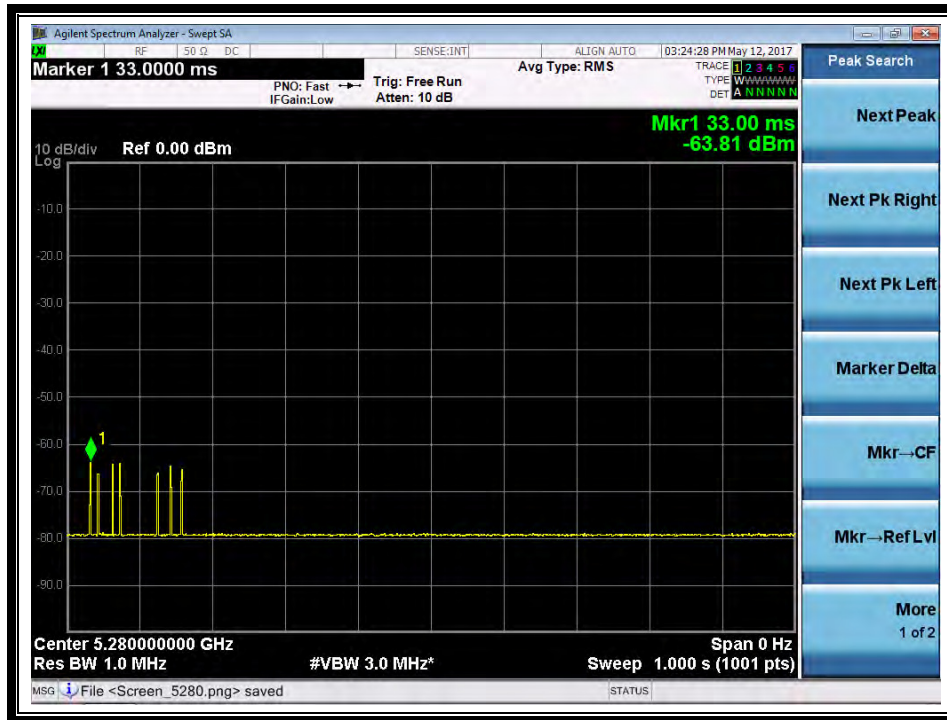

Figure 4: Example Conducted Setup where UUT is a Client and Radar Test Waveforms are injected into the Client



2.7.3 Test Result

2.7.3.1 Radar Test Waveforms are injected into the Master:



2.7.3.2 EUT is a Client Device Without Radar Detection :

Channel & Bandwidth	Requirement	Operational Mode	Test Result	Limit	Verdict
		Client Without Radar Detection			
20MHz 5260MHz	Channel Move Time	Yes	8.47s	<10s	Pass
	Channel Closing Transmission Time	Yes	0.03s	<1s	Pass
	Non-occupancy period	Yes	≥30	≥30 Minutes	Pass
40MHz 5510MHz	Channel Move Time	Yes	3.48s	<10s	Pass
	Channel Closing Transmission Time	Yes	0.08s	<1s	Pass
	Non-occupancy period	Yes	≥30	≥30 Minutes	Pass

2.7.3.3 Test Plots

Note: T0 denotes the start time of the Radar single transmitted, T1 denotes the end time of the Radar single transmit end. T2 denotes the data transmission time of 200ms from T1. T3 denotes the end of the Channel Move Time, the time of T3 from T1 is less than 12s.



20MHz/5300MHz:

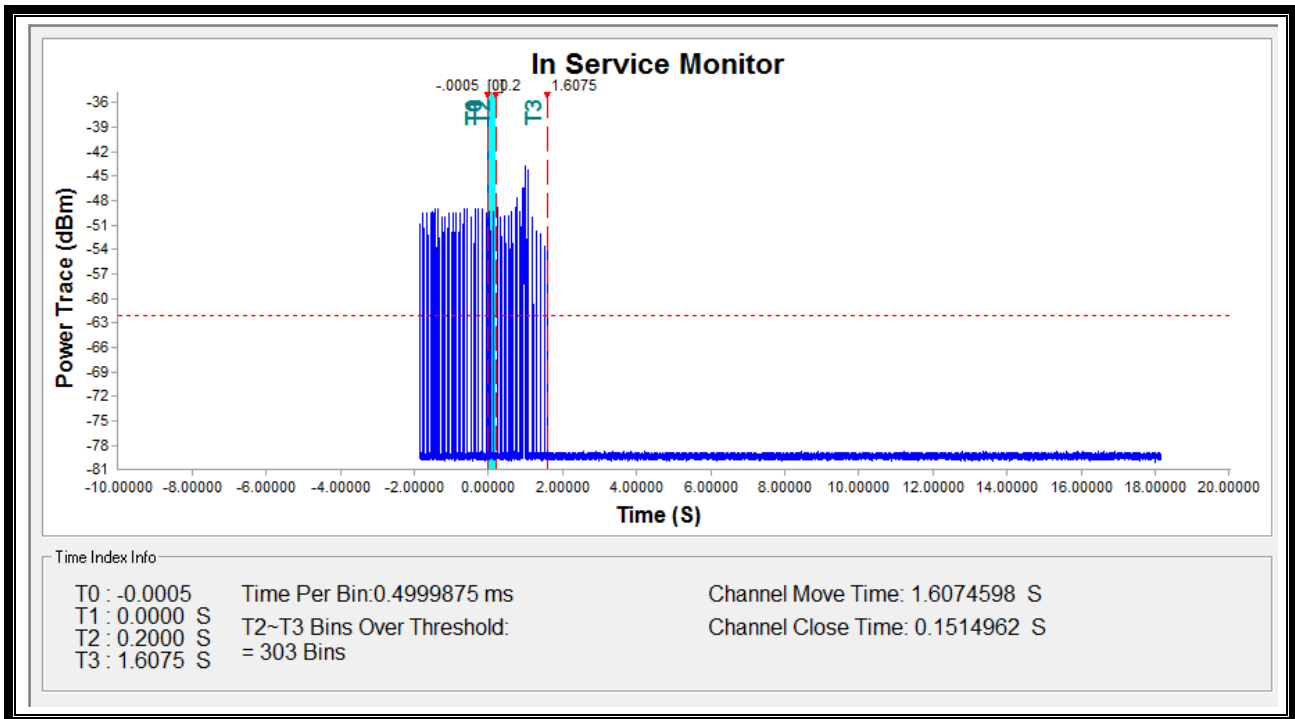

40MHz/5590MHz:

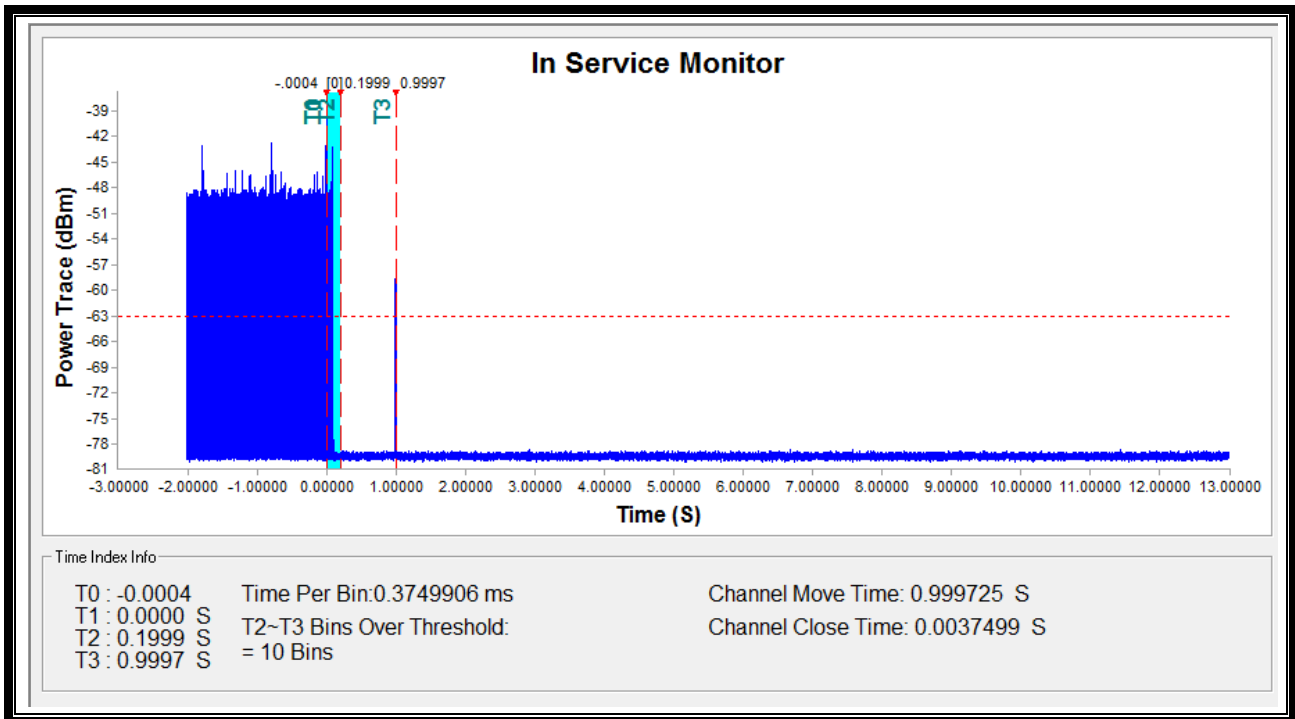

80MHz/5530MHz:

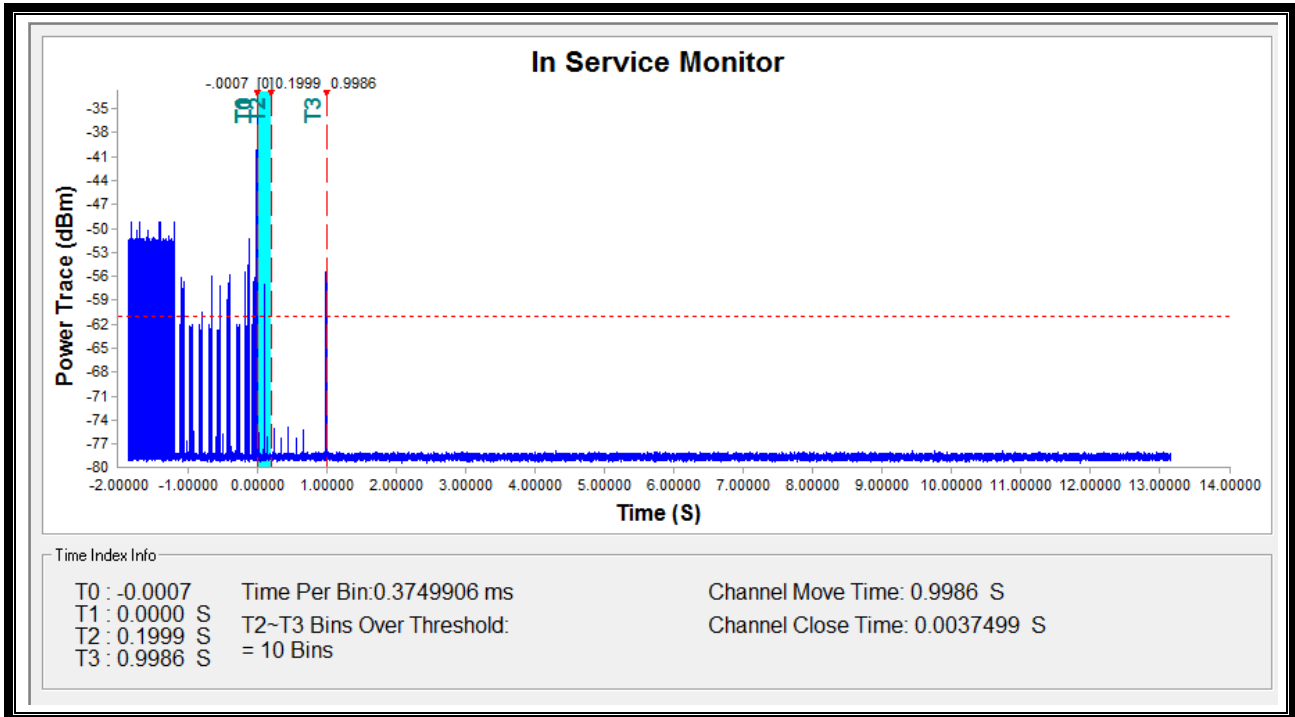

2.7.3.4 Test Photo for DFS



2.8 Conducted Emission

2.8.1 Requirement

According to FCC section 15.207, for an intentional radiator that is designed to be connected to the public utility (AC) power line, the radio frequency voltage that is conducted back onto the AC power line on any frequency within the band 150kHz to 30MHz shall not exceed the limits in the following table, as measured using a 50 μ H/50 Ω line impedance stabilization network (LISN).

Frequency range (MHz)	Conducted Limit (dB μ V)	
	Quai-peak	Average
0.15 - 0.50	66 to 56	56 to 46
0.50 - 5	56	46
5 - 30	60	50

NOTE:

- (a) The lower limit shall apply at the band edges.
- (b) The limit decreases linearly with the logarithm of the frequency in the range 0.15 - 0.50MHz.

2.8.2 Test Description

A. Test Setup:

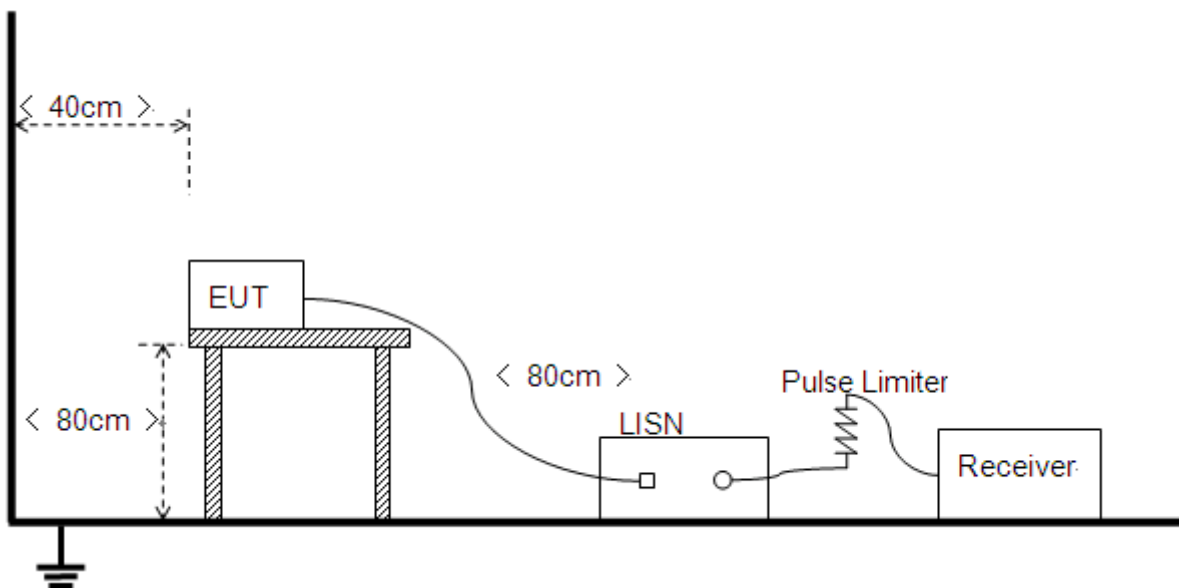

The Table-top EUT was placed upon a non-metallic table 0.8m above the horizontal metal reference ground plane. EUT was connected to LISN and LISN was connected to reference Ground Plane. EUT was 80cm from LISN. The set-up and test methods were according to ANSI C63.10: 2013.

The EUT is powered by the Battery charged with the AC Adapter which is powered by 120V, 60Hz AC mains supply. The factors of the site are calibrated to correct the reading. During the



measurement, the EUT is activated and controlled by the Wi-Fi Service Supplier (SS) via a Common Antenna.

2.8.3 Test Result

The maximum conducted interference is searched using Peak (PK), if the emission levels more than the AV and QP limits, and that have narrow margins from the AV and QP limits will be re-measured with AV and QP detectors. Tests for both L phase and N phase lines of the power mains connected to the EUT are performed. Refer to recorded points and plots below.

Note: All test modes are performed, only the worst case is recorded in this report.

A. Test setup:

The EUT configuration of the emission tests is EUT + Link.

Note: The test voltage is AC 120V/60Hz.

B. Test Plots:

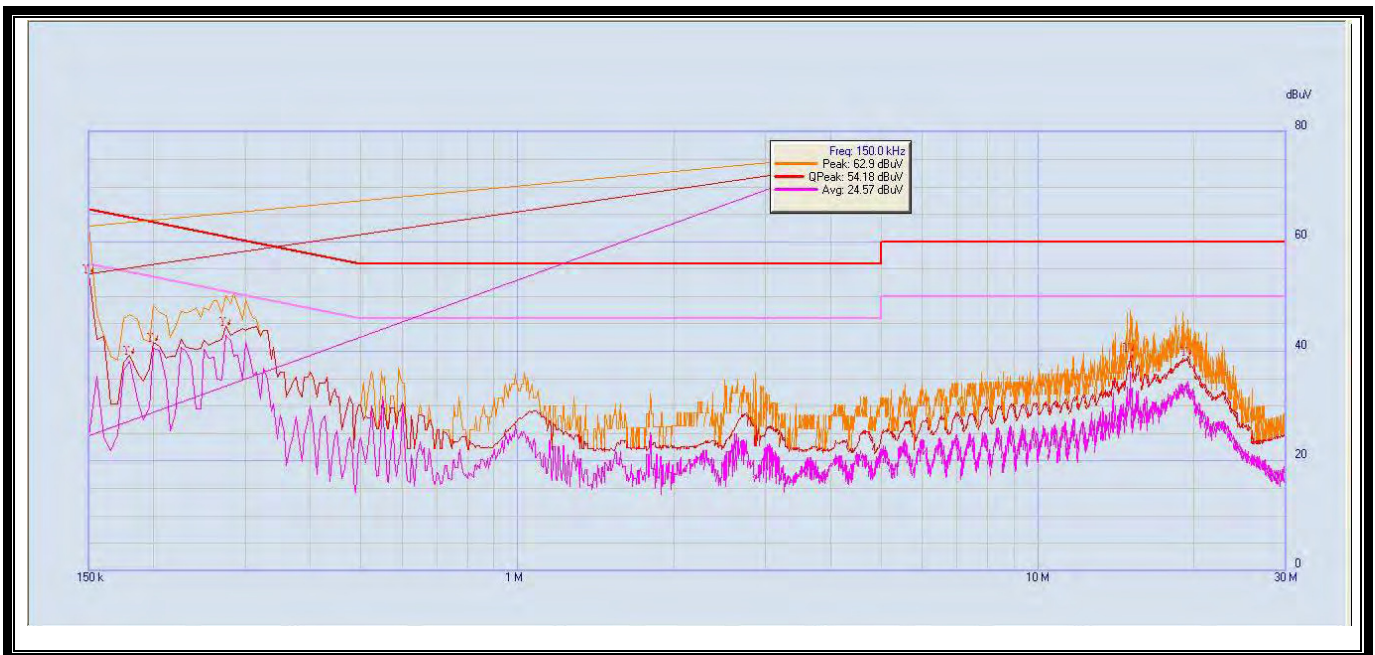

(Plot A: L Phase)

NO.	Fre. (MHz)	Emission Level (dBµV)		Limit (dBµV)		Power-line	Verdict
		Quai-peak	Average	Quai-peak	Average		
1	0.15	54.18	24.57	66	56	Line	PASS
2	0.18	39.24	38.12	65.14	55.14		PASS
3	0.2	41.61	40.59	64.57	54.57		PASS
4	0.275	44.50	42.92	62.43	52.43		PASS
5	15	39.05	35.03	60	50		PASS
6	19.305	38.40	33.14	60	50		PASS

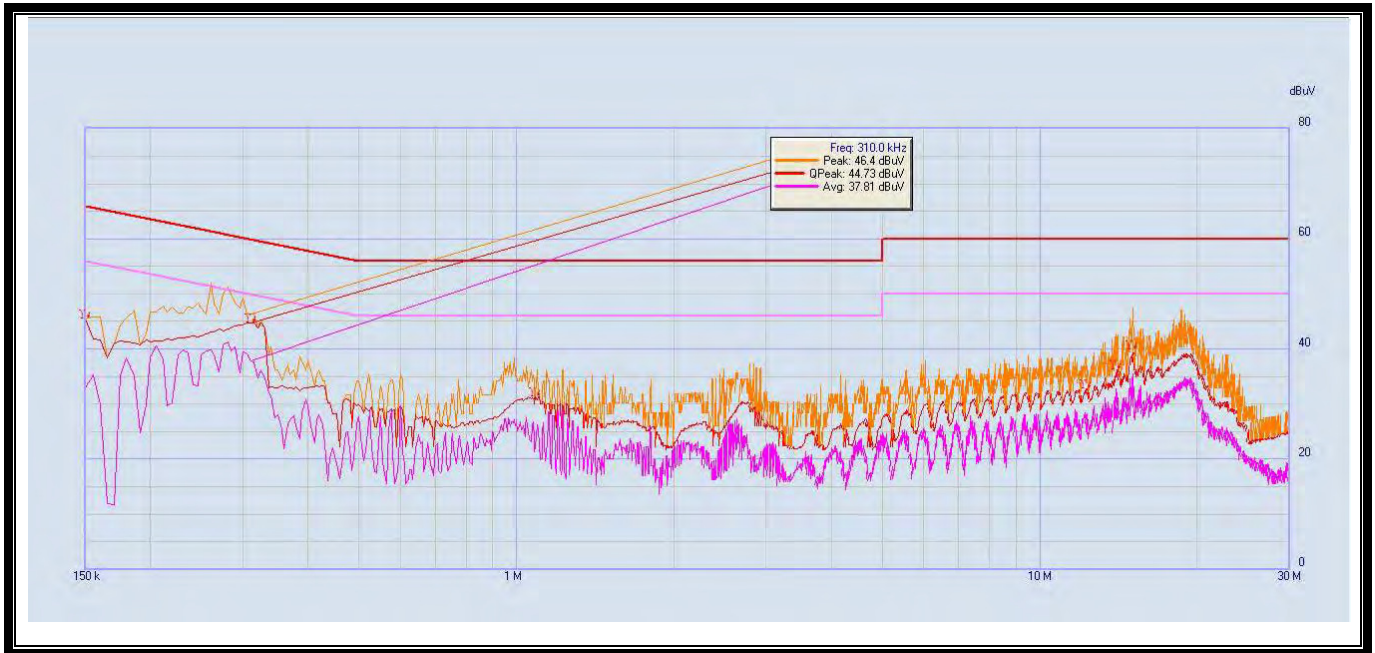

(Plot B: N Phase)

NO.	Fre. (MHz)	Emission Level (dBµV)		Limit (dBµV)		Power-line	Verdict
		Quai-peak	Average	Quai-peak	Average		
1	0.15	45.45	32.91	66	56	Neutral	PASS
2	0.31	44.73	37.81	61.43	51.43		PASS
3	1.09	31.33	22.30	39.14	29.14		PASS
4	12.225	32.72	27.91	60	50		PASS
5	13.96	35.41	31.96	60	50		PASS
6	14.985	38.99	35.23	60	50		PASS



2.9 Radiated Emission

2.9.1 Requirement

The peak emissions outside of the frequency bands of operation shall be attenuated in accordance with the following limits:

- (1) For transmitters operating in the 5.15–5.25 GHz band: all emissions outside of the 5.15–5.35 GHz band shall not exceed an EIRP of -27dBm/MHz.
- (2) For transmitters operating in the 5.25–5.35 GHz band: all emissions outside of the 5.15–5.35 GHz band shall not exceed an EIRP of -27dBm/MHz.
- (3) For transmitters operating in the 5.47–5.725 GHz band: all emissions outside of the 5.47–5.725 GHz band shall not exceed an EIRP of -27dBm/MHz.
- (4) For transmitters operating in the 5.725-5.85 GHz band: All emissions within the frequency range from the band edge to 10 MHz above or below the band edge shall not exceed an e.i.r.p. of -17 dBm/MHz; for frequencies 10 MHz or greater above or below the band edge, emissions shall not exceed an e.i.r.p. of -27 dBm/MHz.

The following formula is used to convert the equipment isotropic radiated power(eirp) to field strength (dBμV/m);

$$E = 1000000 \times \sqrt{30P} / 3 \mu\text{V/m}$$

where P is the EIRP in Watts

Therefore: -27 dBm/MHz = 68.23 dBuV/m

Unwanted emissions below 1 GHz must comply with the general field strength limits set forth in § 15.209. According to FCC section 15.209 (a), except as provided elsewhere in this subpart, the emissions from an intentional radiator shall not exceed the field strength levels specified in the following table:

Frequency (MHz)	Field Strength (μV/m)	Measurement Distance (m)
0.009 - 0.490	2400/F(kHz)	300
0.490 - 1.705	24000/F(kHz)	30
1.705 - 30.0	30	30
30 - 88	100	3
88 - 216	150	3
216 - 960	200	3
Above 960	500	3

Note:

For Above 1000MHz, the emission limit in this paragraph is based on measurement instrumentation employing an average detector, measurement using instrumentation with a peak detector function, corresponding to 20dB above the maximum permitted average limit.

In addition, radiated emissions which fall in the restricted bands, as defined in Section 15.205(a), also should comply with the radiated emission limits specified in Section 15.209(a)(above table)

2.9.2 Test Description

A. Test Setup:

- 1) For radiated emissions from 9kHz to 30MHz

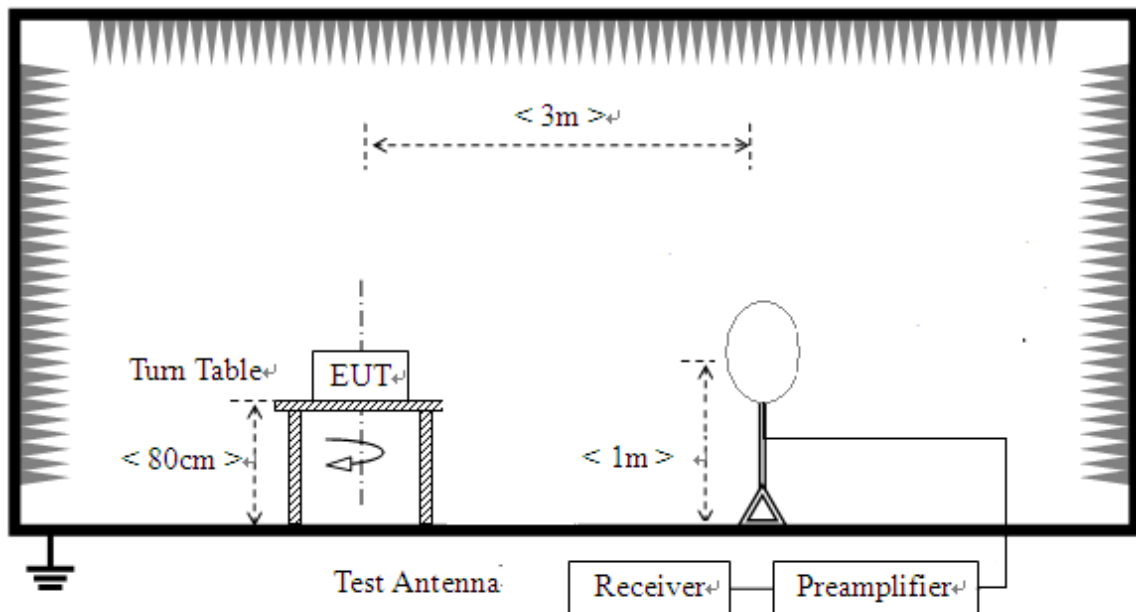

2) For radiated emissions from 30MHz to1GHz

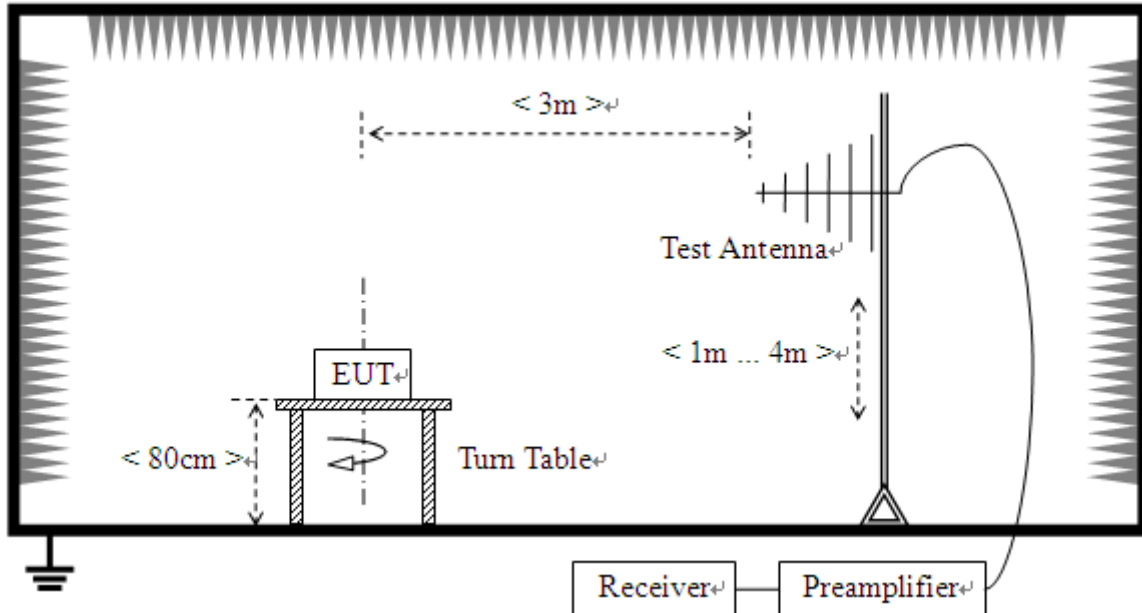

3) For radiated emissions above 1GHz

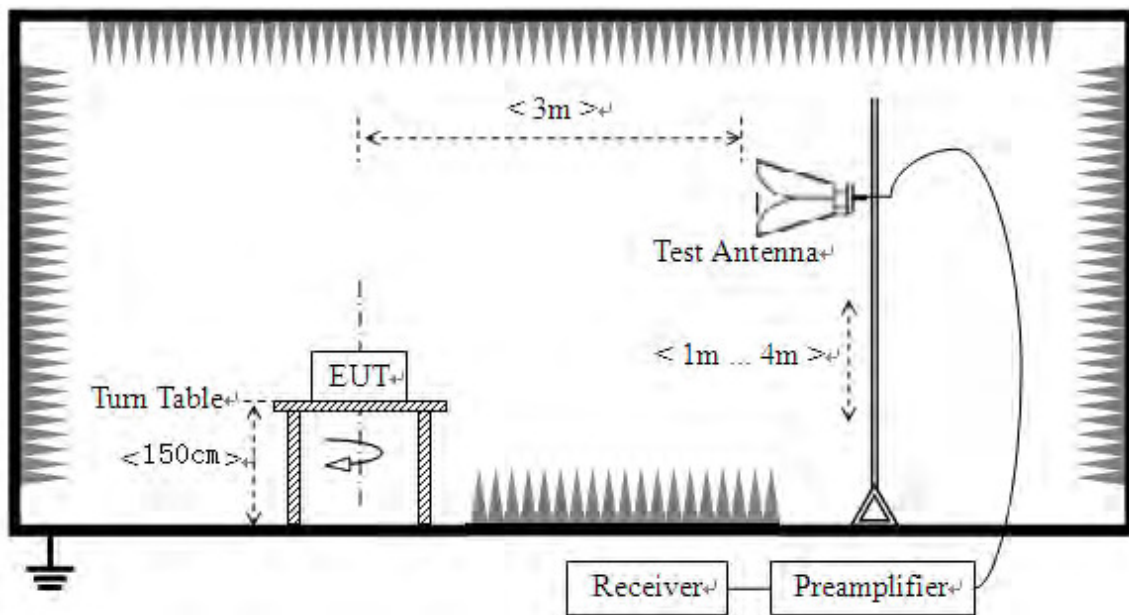

The RF absorbing material used on the reference ground plane and on the turntable have a maximum height (thickness) of 30 cm (12 in) and have a minimum-rated attenuation of 20 dB at all frequencies from 1 GHz to 18 GHz. Test site have a minimum area of the ground plane covered with RF absorbing material as specified in Figure 6 of ANSI C63.4: 2014.

The test site semi-anechoic chamber has met the requirement of NSA tolerance 4dB according to



the standards: ANSI C63.10 (2013). For radiated emissions below or equal to 1GHz, The EUT was set-up on insulator 80cm above the Ground Plane, For radiated emissions above 1GHz, The EUT was set-up on insulator 150cm above the Ground Plane. The set-up and test methods were according to ANSI C63.10

For the radiated emission test above 1GHz:

Place the measurement antenna away from each area of the EUT determined to be a source of emissions at the specified measurement distance, while keeping the measurement antenna aimed at the source of emissions at each frequency of significant emissions, with polarization oriented for maximum response. The measurement antenna may have to be higher or lower than the EUT, depending on the radiation pattern of the emission and staying aimed at the emission source for receiving the maximum signal. The final measurement antenna elevation shall be that which maximizes the emissions. The measurement antenna elevation for maximum emissions shall be restricted to a range of heights of from 1 m to 4 m above the ground or reference ground plane.

The EUT is located in a 3m Semi-Anechoic Chamber; the antenna factors, cable loss and so on of the site as factors are calculated to correct the reading

For the Test Antenna:

(a) In the frequency range of 9kHz to 30MHz, magnetic field is measured with Loop Test Antenna. The Test Antenna is positioned with its plane vertical at 1m distance from the EUT. The center of the Loop Test Antenna is 1m above the ground. During the measurement the Loop Test Antenna rotates about its vertical axis for maximum response at each azimuth about the EUT.

(b) In the frequency range above 30MHz, Bi-Log Test Antenna (30MHz to 1GHz) and Horn Test Antenna (above 1GHz) are used. Place the test antenna at 3m away from area of the EUT, while keeping the test antenna aimed at the source of emissions at each frequency of significant emissions, with polarization oriented for maximum response. The test antenna may have to be higher or lower than the EUT, depending on the radiation pattern of the emission and staying aimed at the emission source for receiving the maximum signal. The final test antenna elevation shall be that which maximizes the emissions. The test antenna elevation for maximum emissions shall be restricted to a range of heights of from 1 m to 4 m above the ground or reference ground plane. The emission levels at both horizontal and vertical polarizations should be tested.



2.9.3 Test Result

According to ANSI C63.4 selection 4.2.2, because of peak detection will yield amplitudes equal to or greater than amplitudes measured with the quasi-peak (or average) detector, the measurement data from a spectrum analyzer peak detector will represent the worst-case results, if the peak measured value complies with the quasi-peak limit, it is unnecessary to perform an quasi-peak measurement.

The measurement results are obtained as below:

$$E \text{ [dB}\mu\text{V/m]} = U_R + A_T + A_{\text{Factor}} \text{ [dB]}; A_T = L_{\text{Cable loss}} \text{ [dB]} - G_{\text{preamp}} \text{ [dB]}$$

A_T : Total correction Factor except Antenna

U_R : Receiver Reading

G_{preamp} : Preamplifier Gain

A_{Factor} : Antenna Factor at 3m

During the test, the total correction Factor A_T and A_{Factor} were built in test software.

Note1: All radiated emission tests were performed in X, Y, Z axis direction. And only the worst axis test condition was recorded in this test report.

Note2: The low frequency, which started from 9KHz to 30MHz, was pre-scanned and the result which was 20dB lower than the limit line per 15.31(o) was not reported.

For the frequency, which started from 25G to 40G, was pre-scanned and the result which was 10dB lower than the limit.



2.9.3.1 802.11ac-20MHz Test mode

A. Test Plots for the Whole Measurement Frequency Range:

Plots for Channel = 36

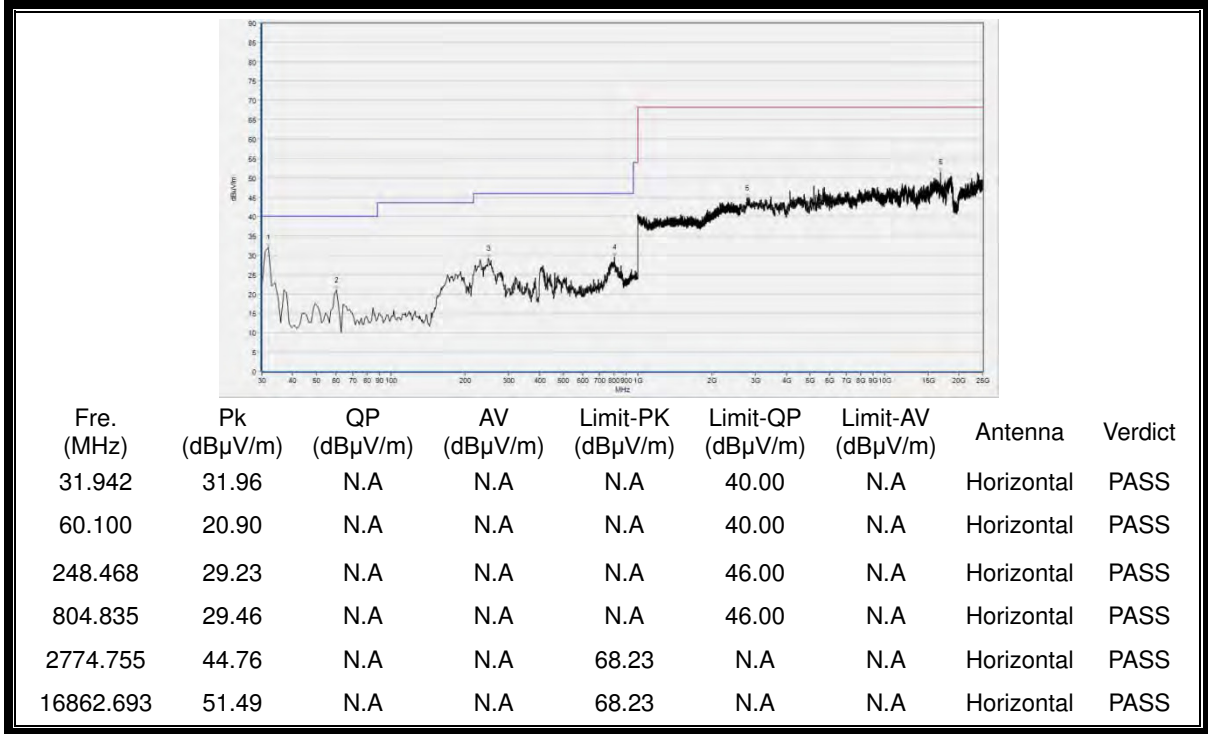

(Antenna Horizontal, 30MHz to 40GHz)

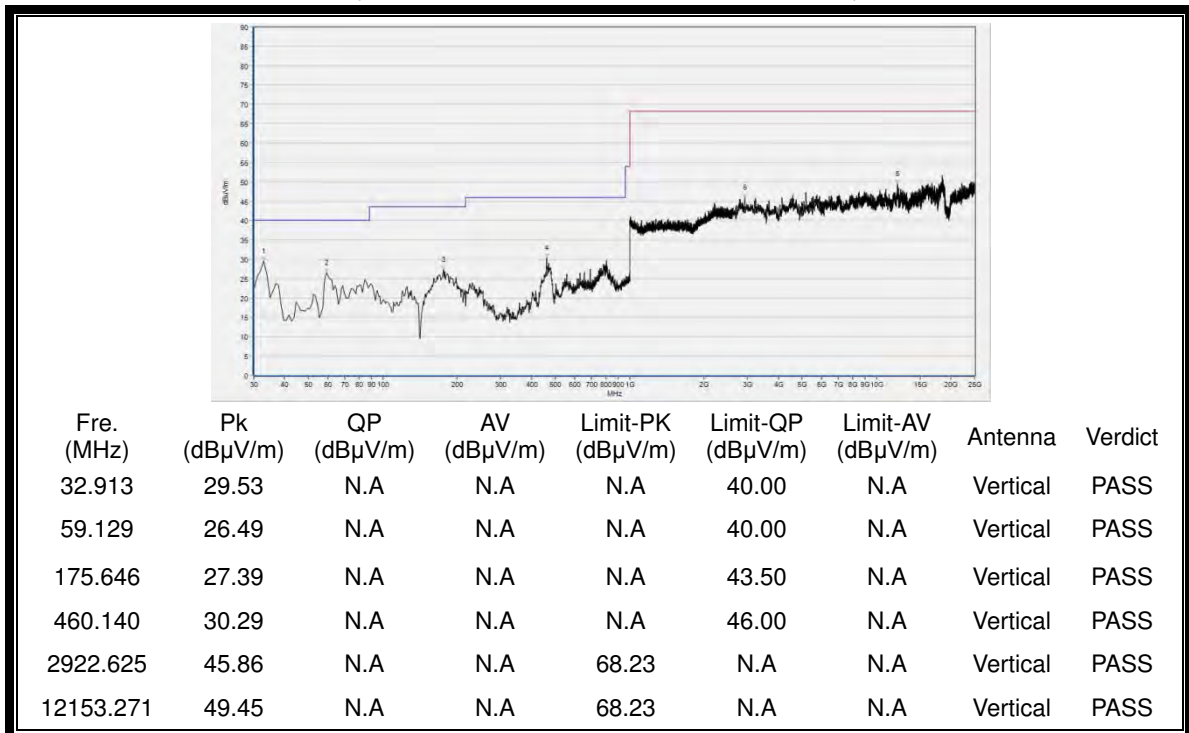

(Antenna Vertical, 30MHz to 40GHz)



Plot for Channel = 44

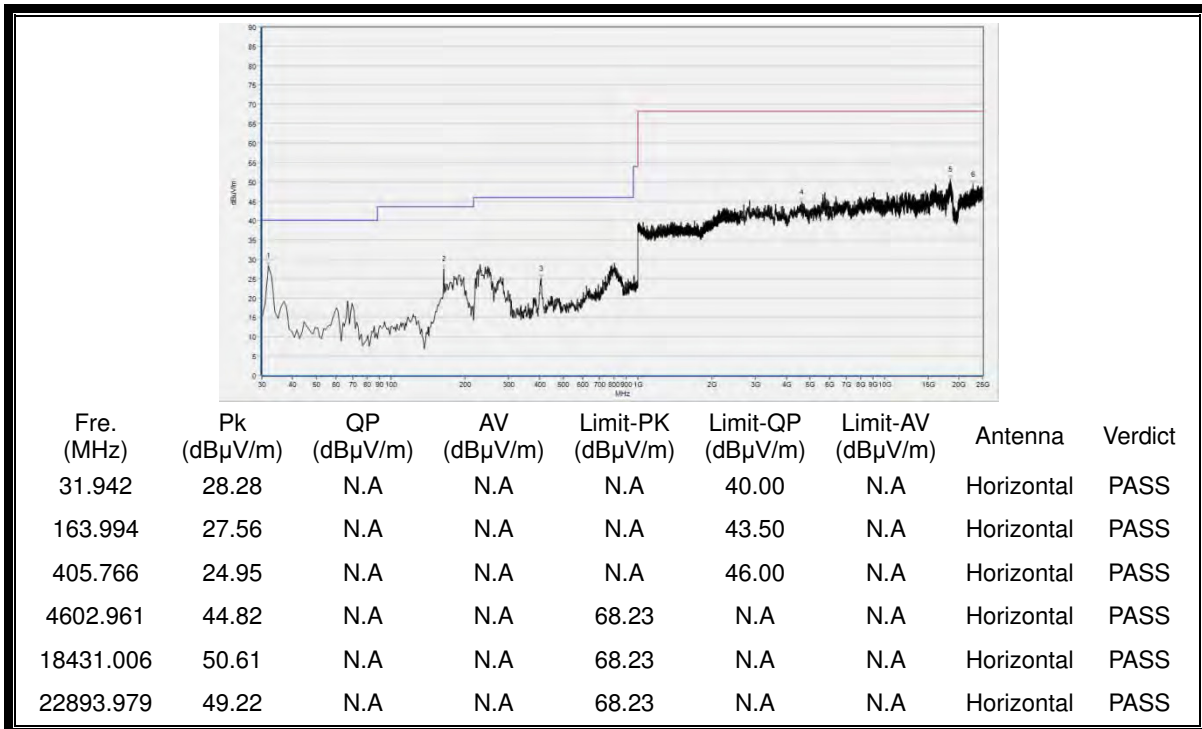

(Antenna Horizontal, 30MHz to 25GHz)

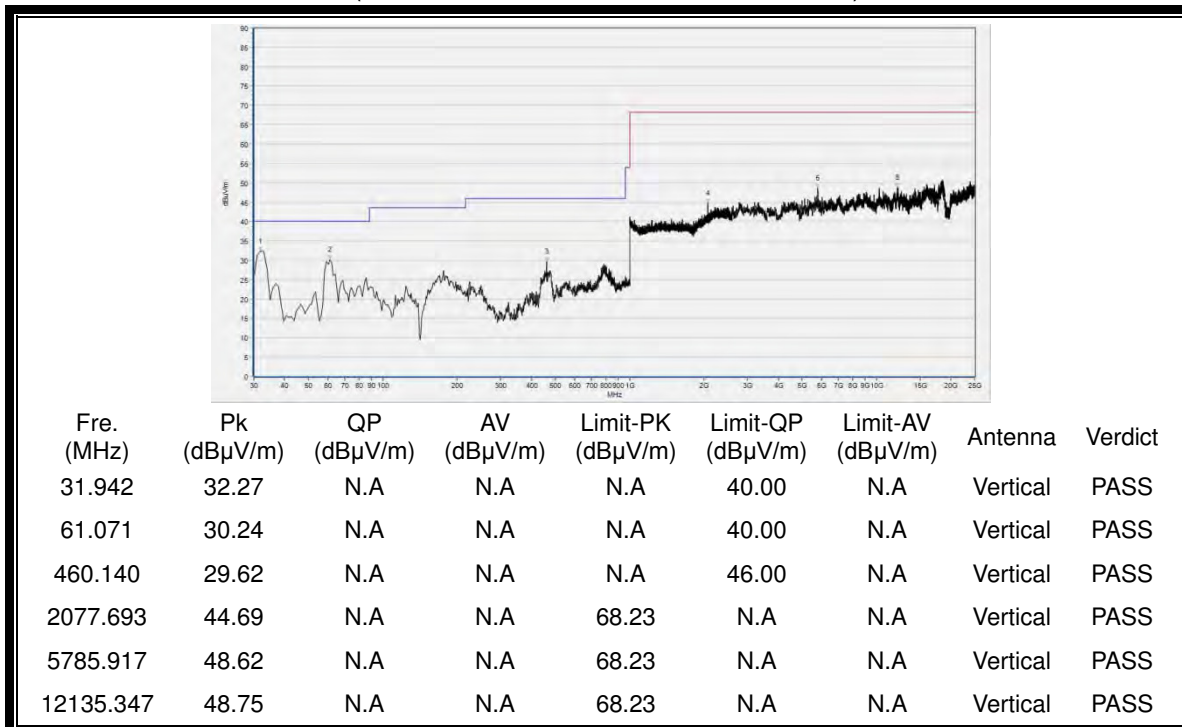

(Antenna Vertical, 30MHz to 40GHz)



Plot for Channel = 48

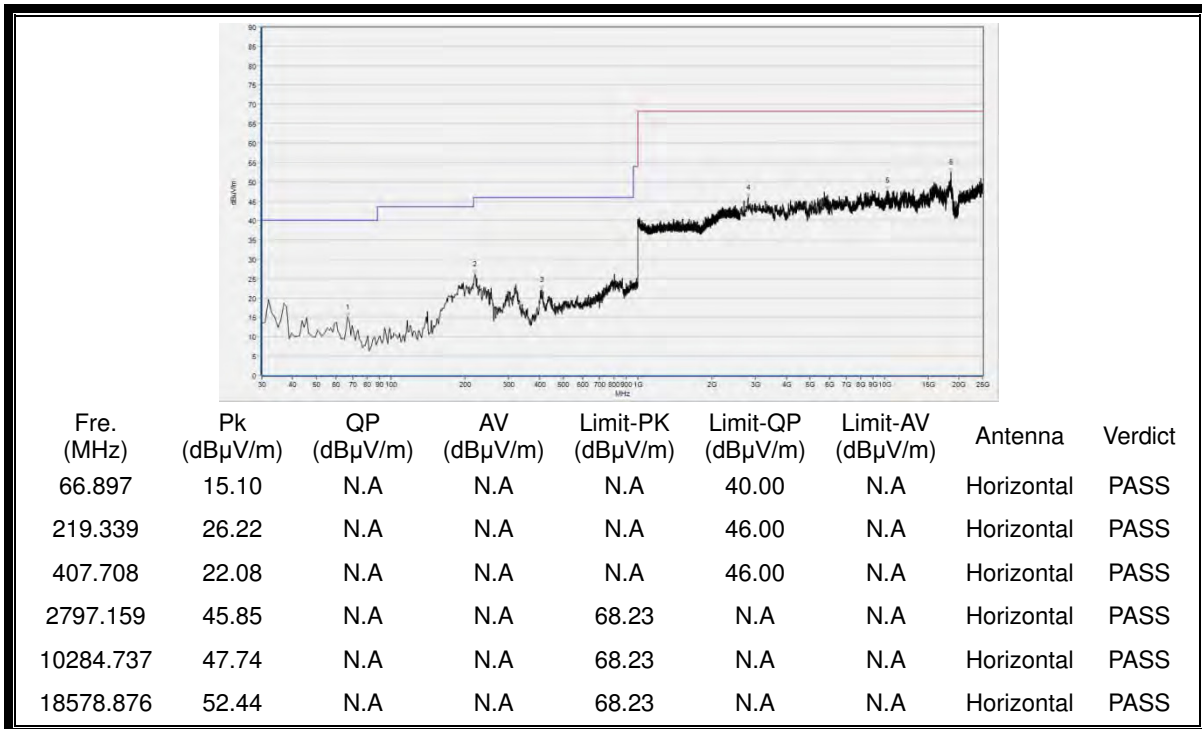

(Antenna Horizontal, 30MHz to 40GHz)

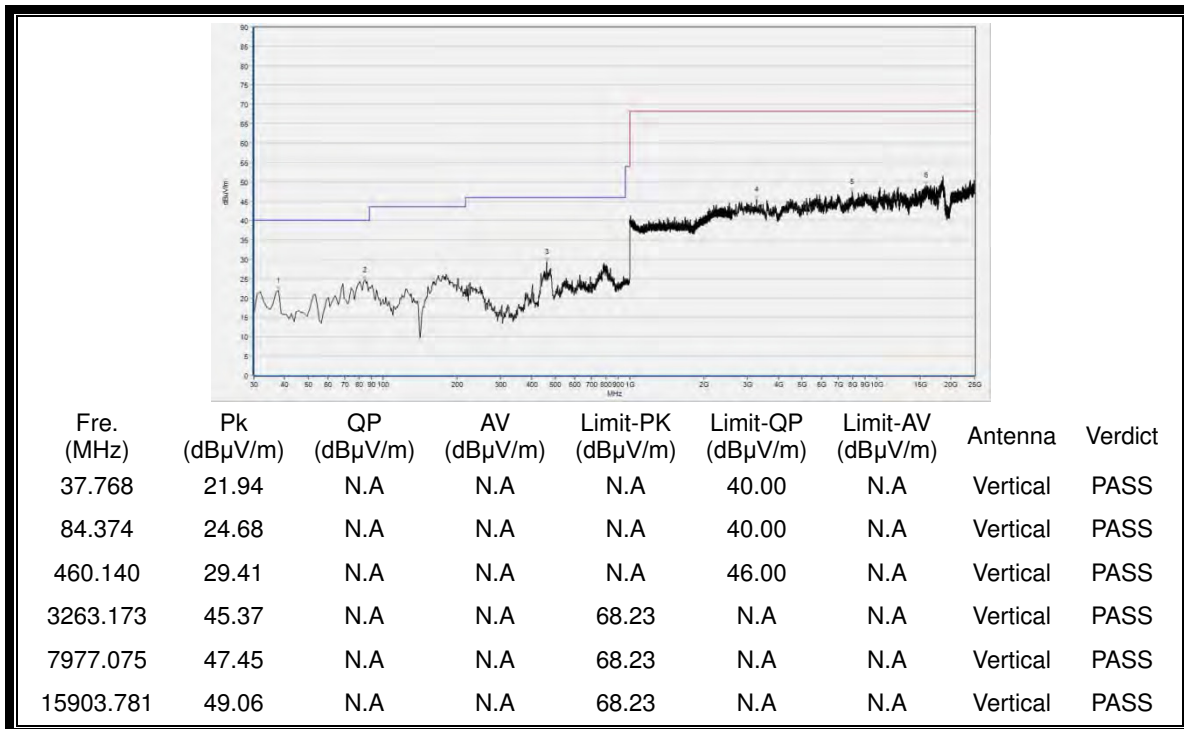

(Antenna Vertical, 30MHz to 40GHz)



Plots for Channel = 52

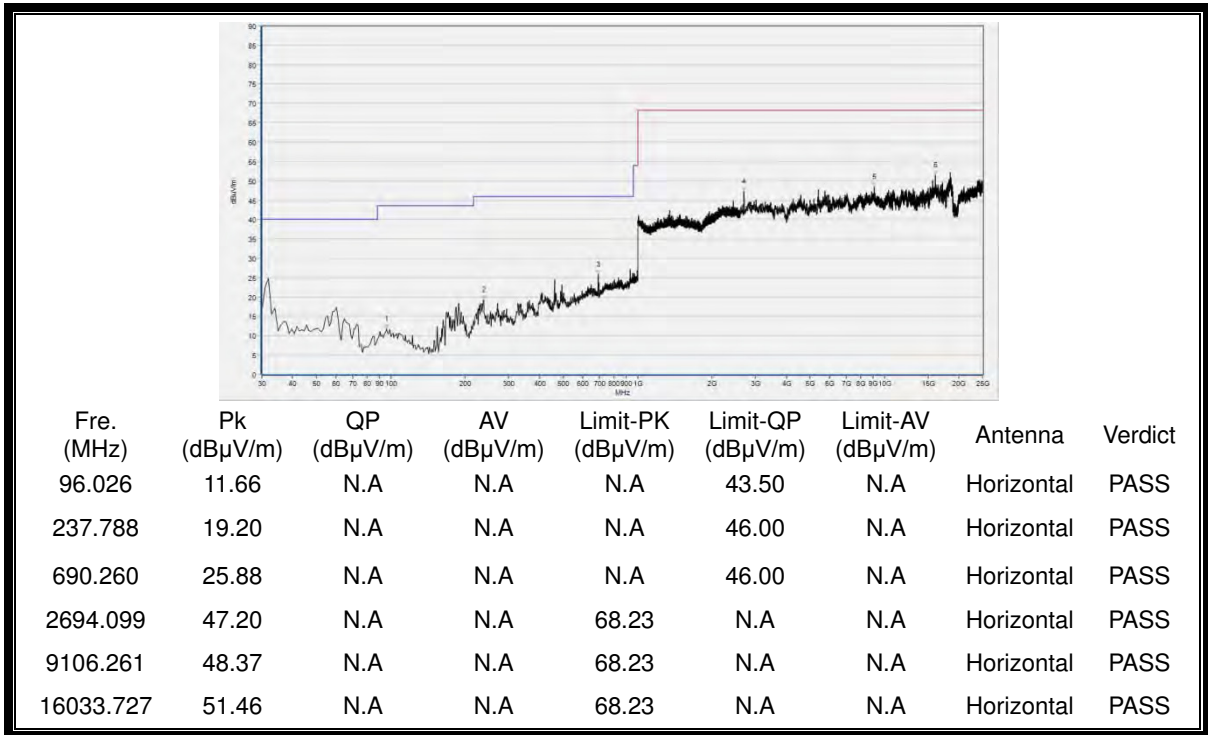

(Antenna Horizontal, 30MHz to 40GHz)

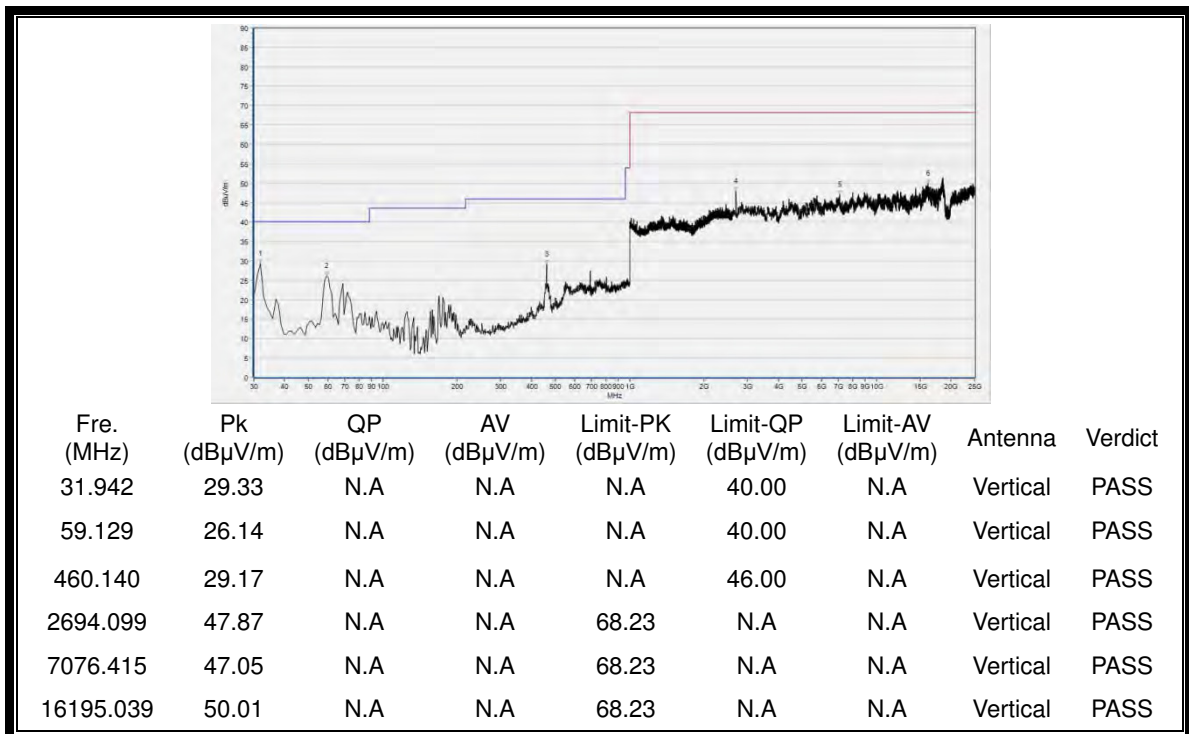

(Antenna Vertical, 30MHz to 40GHz)



Plot for Channel = 60

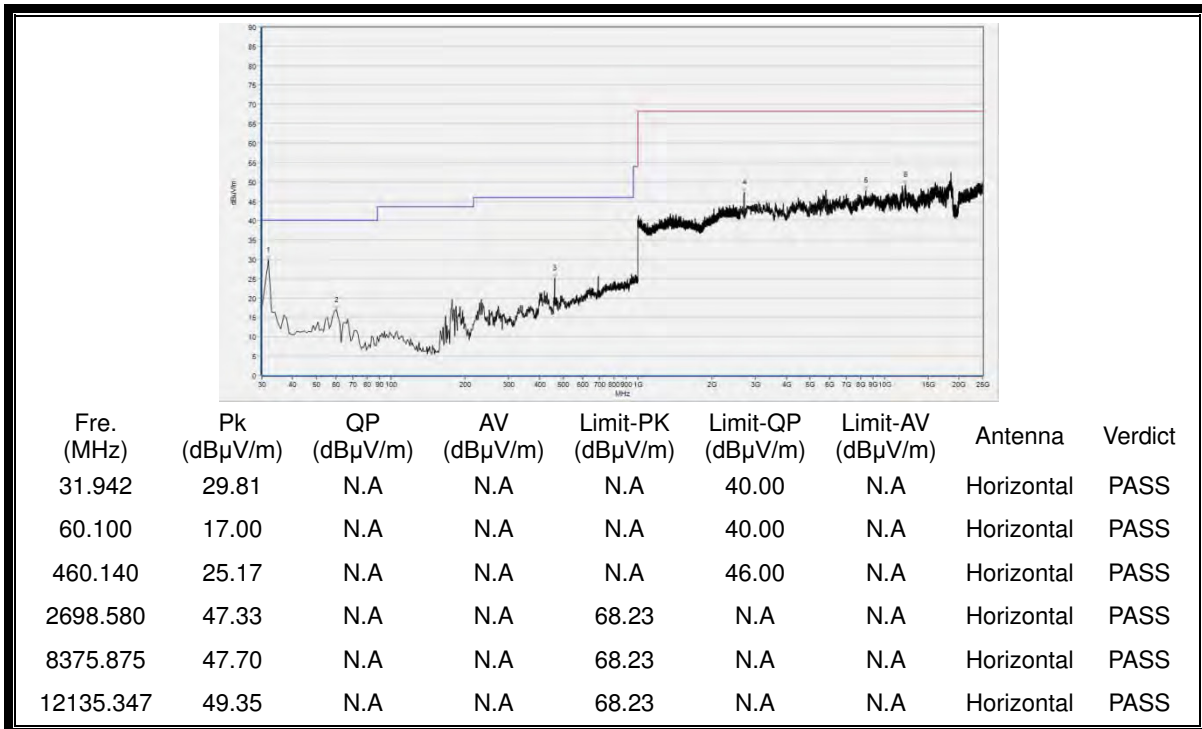

(Antenna Horizontal, 30MHz to 25GHz)

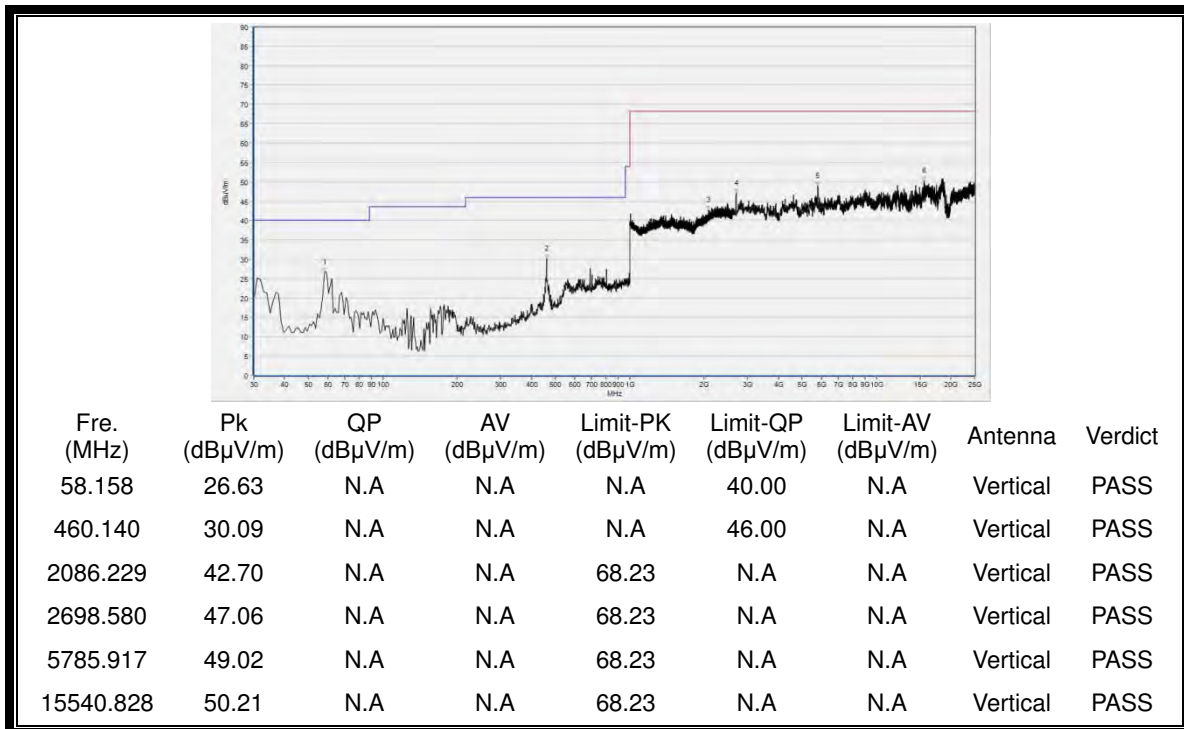

(Antenna Vertical, 30MHz to 40GHz)



Plot for Channel = 64

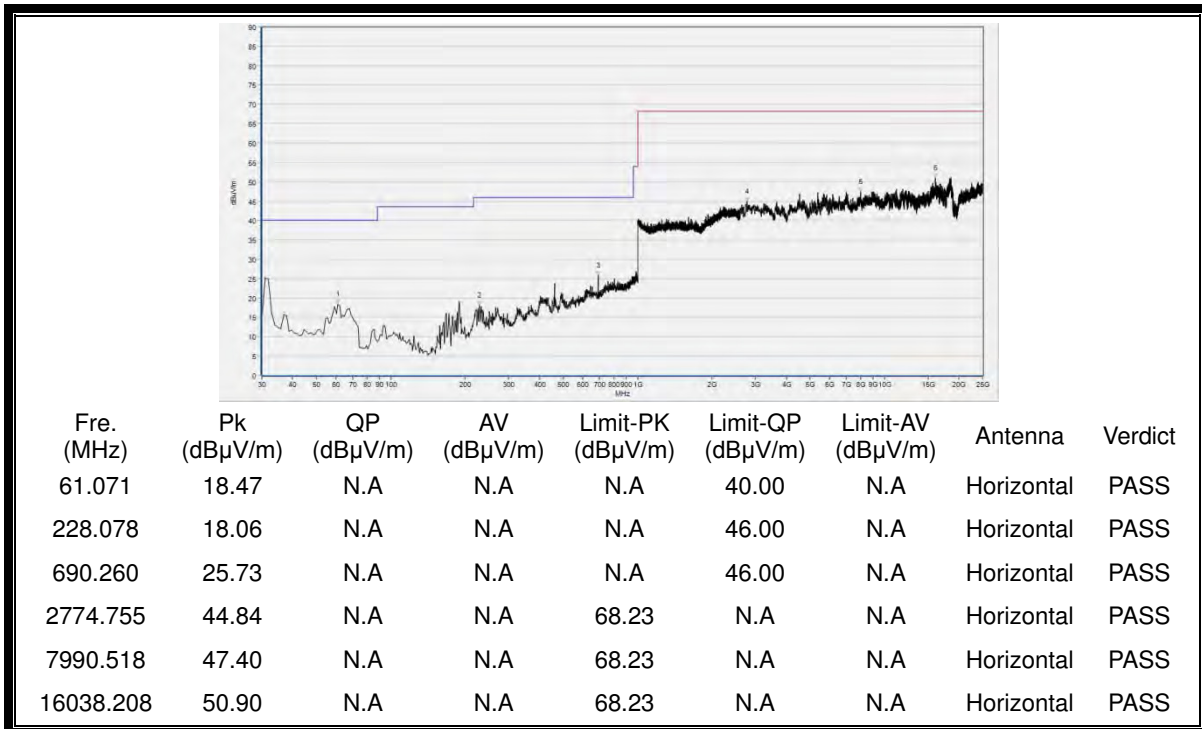

(Antenna Horizontal, 30MHz to 40GHz)

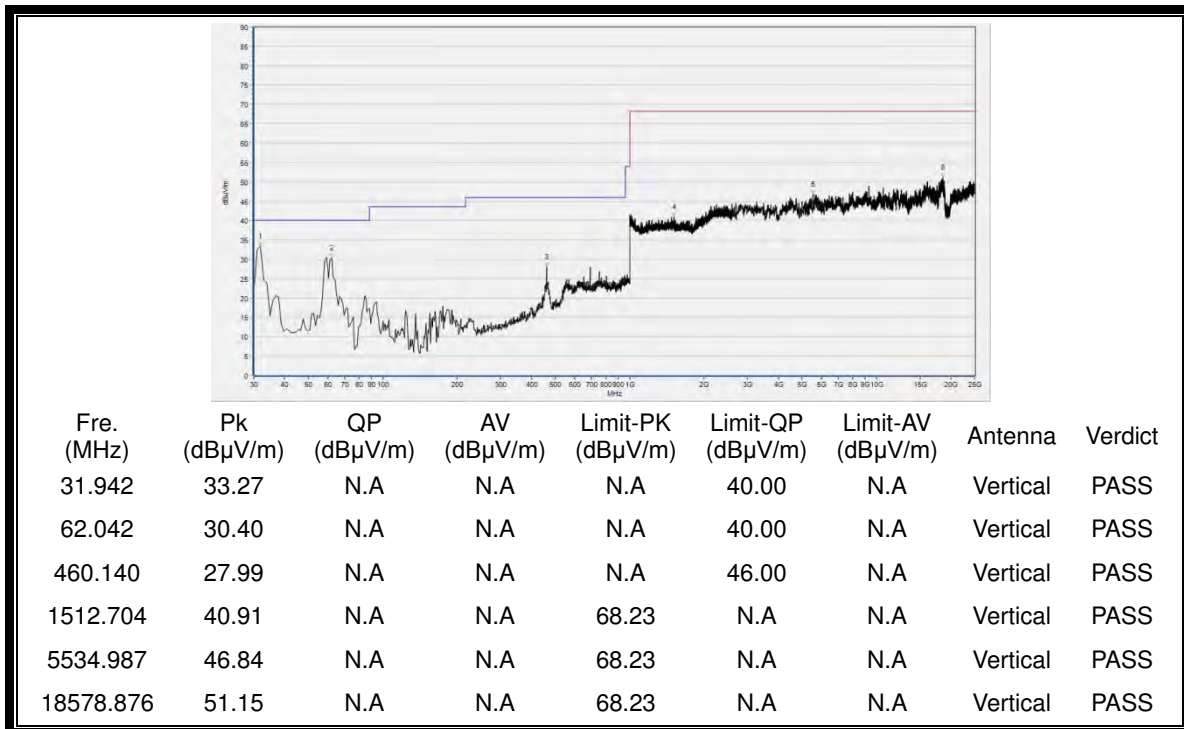

(Antenna Vertical, 30MHz to 40GHz)



Plots for Channel = 100

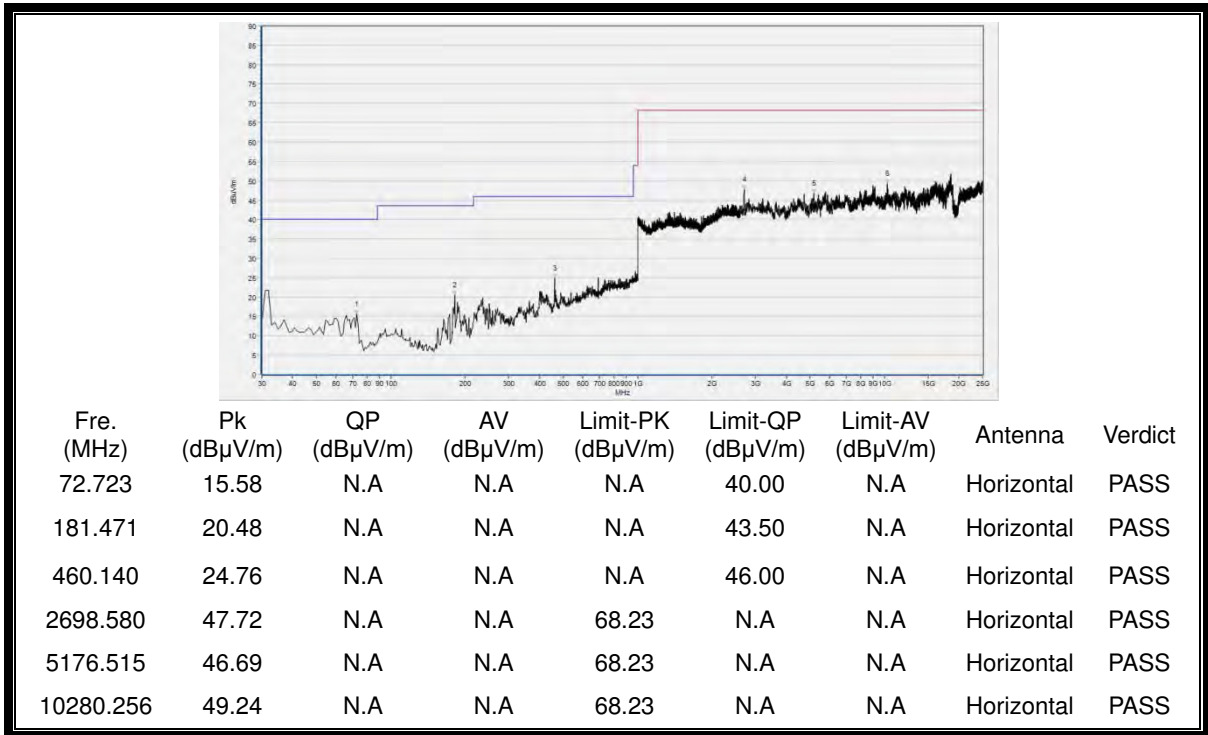

(Antenna Horizontal, 30MHz to 40GHz)

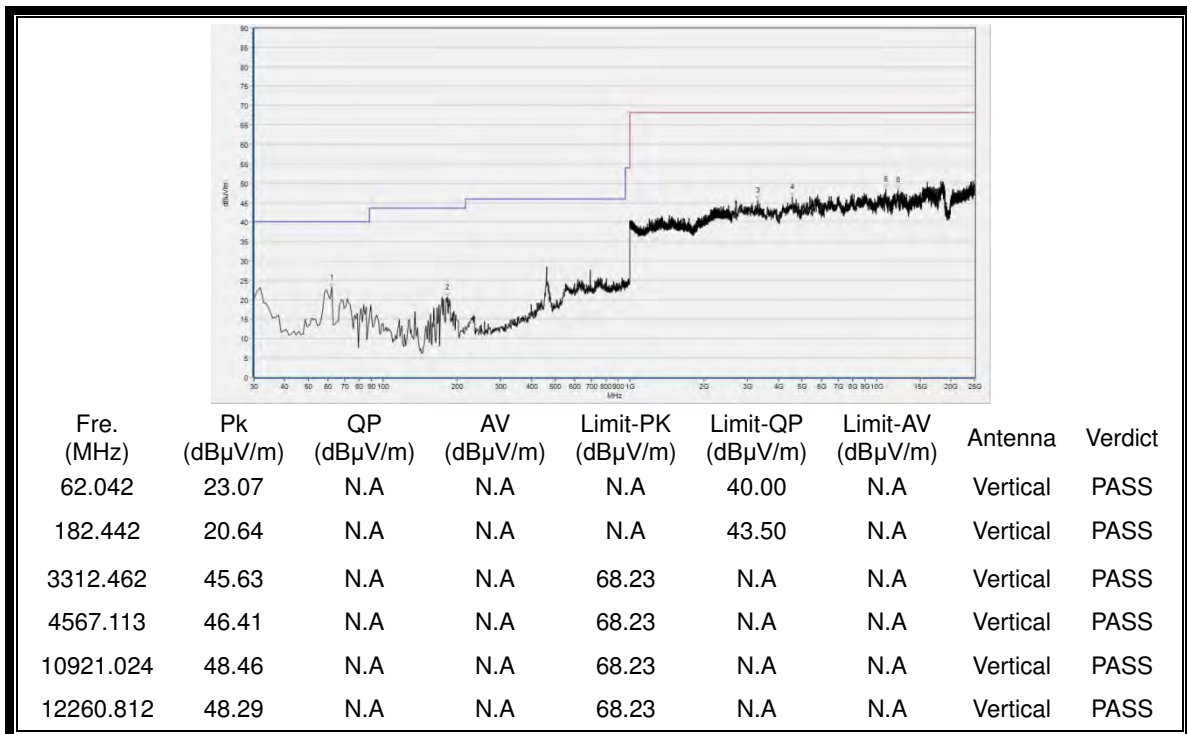

(Antenna Vertical, 30MHz to 40GHz)



Plot for Channel = 120

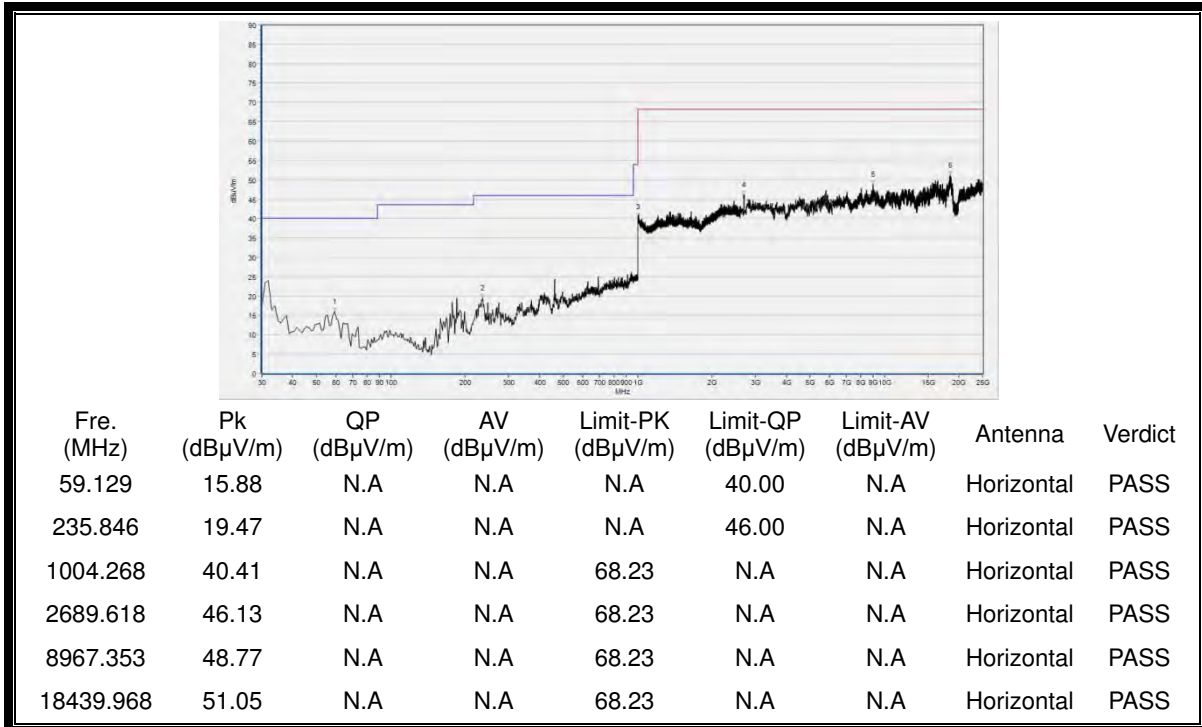

(Antenna Horizontal, 30MHz to 25GHz)

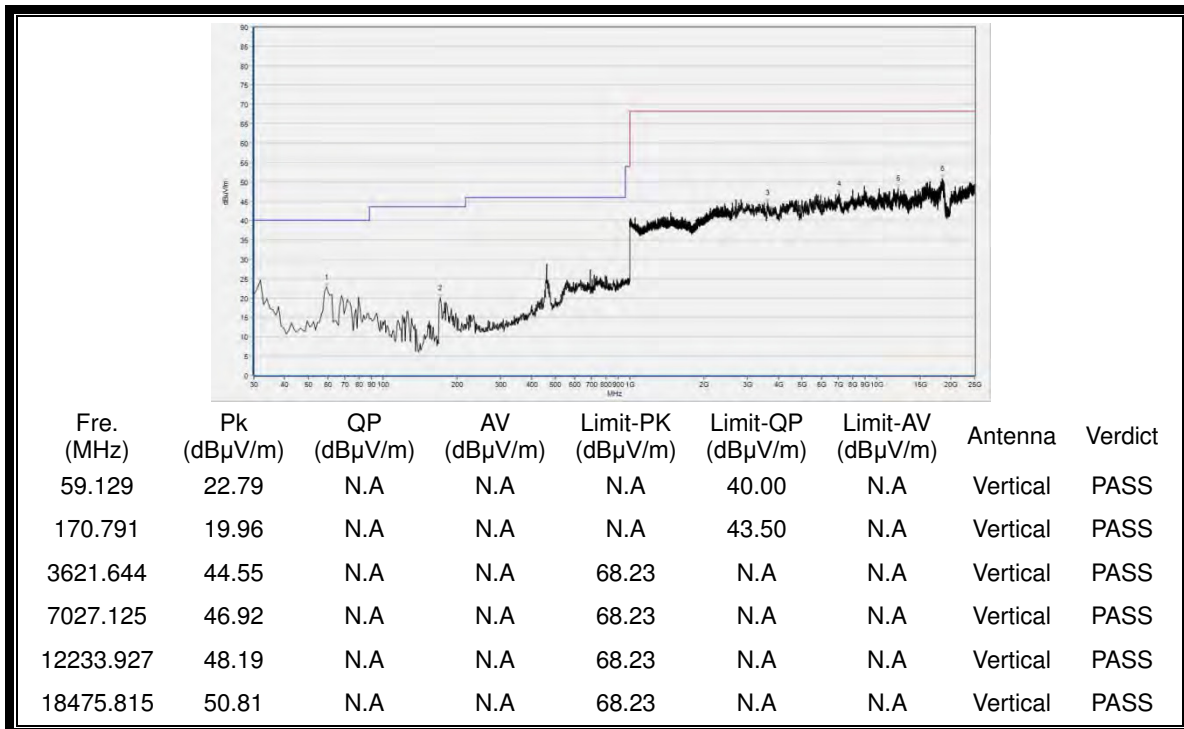

(Antenna Vertical, 30MHz to 40GHz)



Plot for Channel = 140

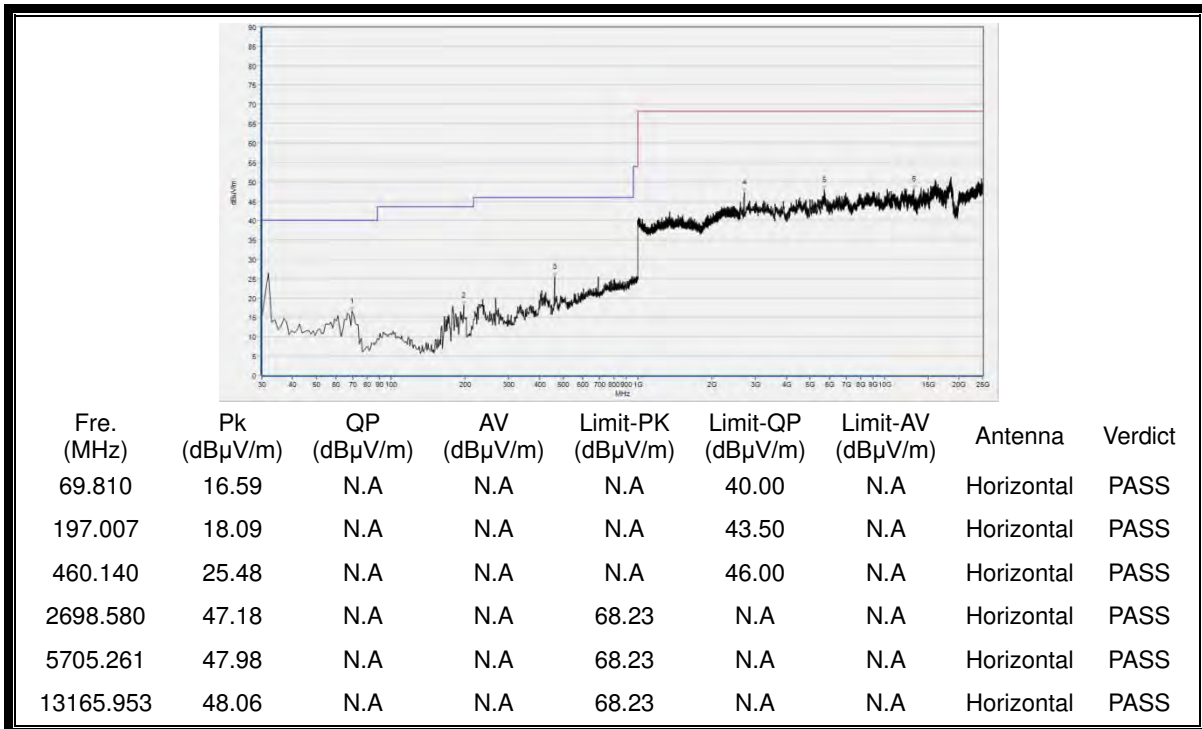

(Antenna Horizontal, 30MHz to 40GHz)

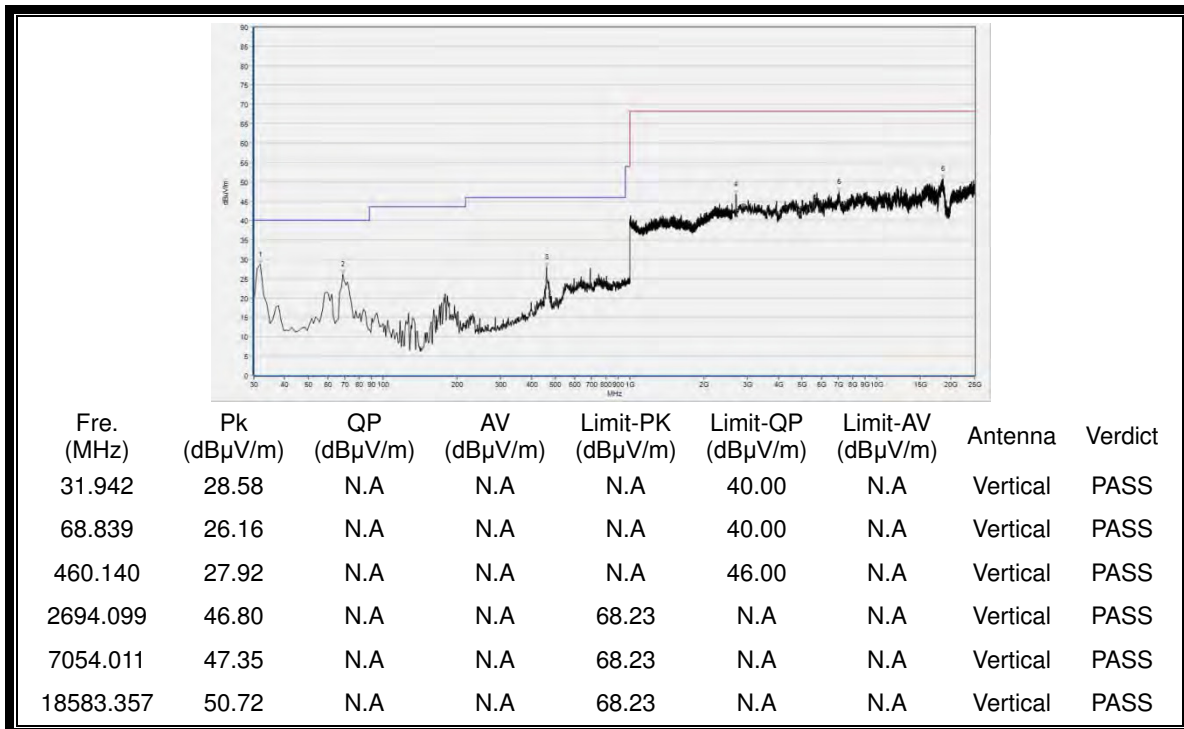

(Antenna Vertical, 30MHz to 40GHz)