

JAXJOX®

Kettlebell Connect™

Model: KB42



TABLE OF CONTENTS

Congratulations _____	2
What's in the box _____	3
Assembly _____	5
Get started with the JAXJOX® app _____	7
Use the Kettlebell Connect™ ____	13
Troubleshooting _____	18
Safety warnings _____	23
Satisfaction guarantee _____	25
Limited warranty _____	26
How to obtain warranty service _	27
Questions or Concerns _____	27
Notices _____	28

Congratulations

Congratulations on your purchase of the JAXJOX® Kettlebell Connect™, an innovative training tool designed to help you achieve your fitness goals. Its elegant design and advanced technology result in a single kettlebell that adjusts from 12 lbs (5.4 kg) to 42 lbs (19 kg). By connecting the Kettlebell Connect™ to the JAXJOX® app, you can set your goals, track your workouts, and fully grasp your fitness level with JAXJOX® fitness iQ™.

Read and understand the contents of this manual before attempting to use the Kettlebell Connect™.

What's in the box



Kettlebell Shell

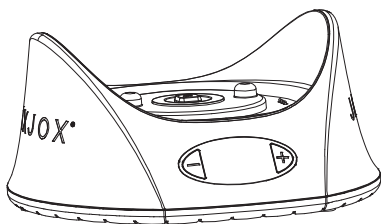

Base

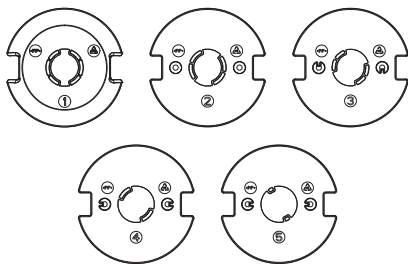

Weights

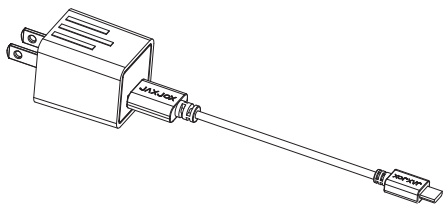

Charging cable & AC adapter

Carefully remove all items from the box and place them on the floor prior to assembly. Verify that all of the components have been included.

*Should you find any parts missing, return the product to your point of purchase or contact JAXJOX® at:
customer.services@jaxjox.com or
(425) 324-3017*

Assembly

Place the base on a solid, level floor

- We recommend using and storing your Kettlebell Connect™ on the floor to minimize risk of injury.

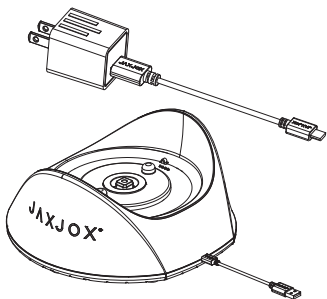

Charge the Kettlebell Connect™

- Plug the charging cable into the AC Adapter.
- Plug the other end of the charging cable into the base of the Kettlebell Connect™.
- Plug the AC Adapter into a power outlet.

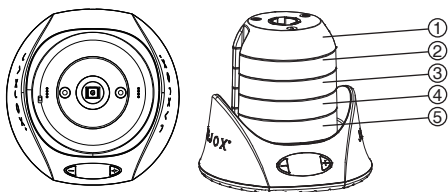

Stack the weights one at a time

- Facing the base's screen, place the weights on the base in reverse order, starting with 5 (on the bottom) and ending with 1 (on the top).

- Ensure the notches are directly to the side, towards the wings of the base. The number on the weight should appear right side up.
- Seat the weights completely, ensuring there are no spaces in between each of the weights.

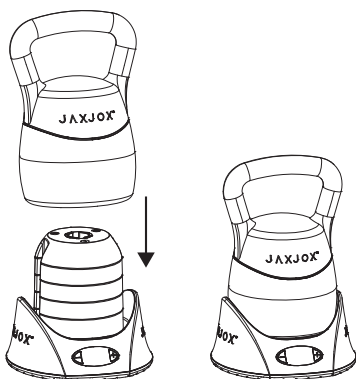

Place the kettlebell shell onto the base

- Lower the kettlebell shell over the top of the weights, ensuring the kettlebell's handles are aligned with the wings of the base.
- You should not need any additional force to seat the kettlebell shell in the base when all of the components are properly aligned.
- When properly seated and ready for use, the Kettlebell Connect™ will beep once.

IMPORTANT: All five weights must be stacked in the correct order for the Kettlebell Connect™ to function properly. Incorrect assembly of the weights and kettlebell shell may result in damage to the Kettlebell Connect™ or result in serious injury.

Get started with the JAXJOX[®] app

The JAXJOX[®] Kettlebell Connect[™] is compatible with mobile devices that support iOS and Android. To get the most from your Kettlebell Connect[™], install the JAXJOX[®] app and connect it with your device.

Download the app from the app store of your device.

- For iOS devices, you must have iOS version 10 or higher installed on your device.
- For Android devices, you must have Android version 5 or higher installed on your device.

If you already have a JAXJOX[®] account, sign in with your email address and password.

If you do not already have an account, create one by entering your email address and a password.

Carrier 10:20 AM

< Account Set Up ≡

 Samantha
Johnson

Height: 5ft 3in

Gender: Female Male

Weight: 123lbs

Birthday: Jun 16, 1987

Fitness Level: Intermediate

NEXT

To get the most out of the JAXJOX[®] app and obtain your JAXJOX[®] fitness iQ[™], complete your profile.

JAXJOX[®] uses your profile information to calculate your JAXJOX[®] fitness iQ[™], a simple, easy to understand measurement of your fitness level.

Note: If you do not have any additional JAXJOX[®] devices connected to the app, or have never tracked your workouts with the JAXJOX[®] app, it will take seven days of workouts before your JAXJOX[®] fitness iQ[™] is calculated.

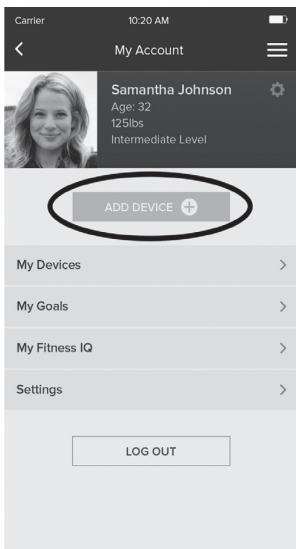

Ensure Bluetooth is turned on for your device.

- Refer to your device's documentation for instructions on how to turn on Bluetooth.

In the JAXJOX® app, press Add Device to add the Kettlebell Connect™.

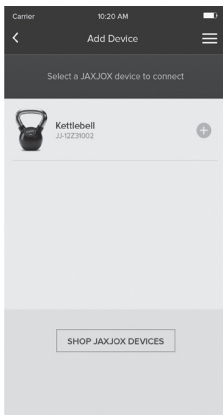

Ensure your Kettlebell Connect™ is charged and nearby.

Choose your Kettlebell Connect™.

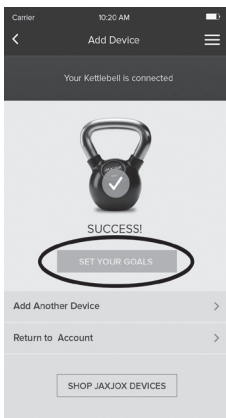

When successfully connected, the success screen displays.

Choose Set Your Goals to define your kettlebell workout goals.

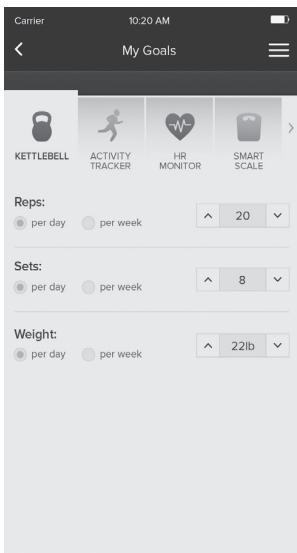

Set your kettlebell workout goals by defining:

- Reps
- Sets
- Weight

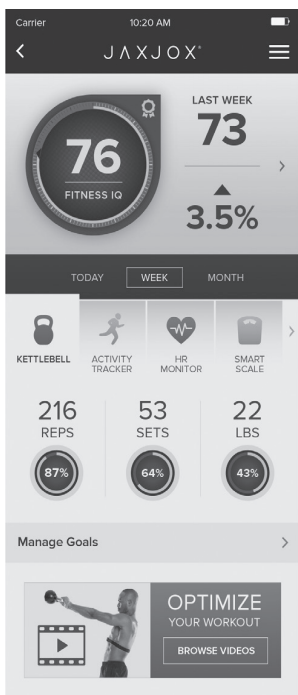

Use the app's dashboard to quickly see the progress you've made on your goals and on your overall fitness with JAXJOX® fitness iQ™.

Take advantage of workout videos in the app to take your fitness to the next level.

Use the Kettlebell Connect™

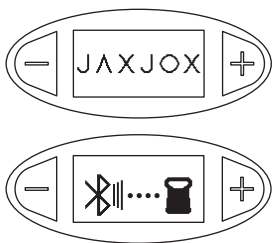

Activate the Kettlebell Connect™

- *Press* either the – or + on the base to activate the Kettlebell Connect™.
- The screen will display a bluetooth logo to remind you to connect the Kettlebell Connect™ with your mobile device and the JAXJOX® app.



Select the person using the Kettlebell Connect™

- *Press and hold* either the – or + button for three seconds and choose the person using the Kettlebell Connect™.
- The Kettlebell Connect™ supports up to 9 users, from P1 to P9.

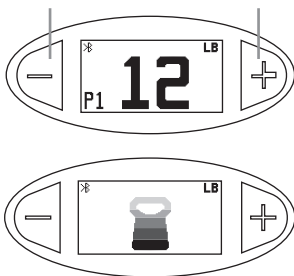

Adjust the weight of the kettlebell

- Press the – or + button to choose the desired weight for your workout.
- The Kettlebell Connect™ can be adjusted from 12 lbs (5.4 kg) to 42 lbs (19 kg) in increments of 6 lbs (2.7 kg).
- Note that you can cycle through the available weight continuously, meaning if you are on 42 lbs (19kg), you can quickly change to 12 lbs (5.4 kg) by pressing the + button.
- The Kettlebell Connect™ takes approximately 3 to 5 seconds to change to your selected weight. The weight loading animation plays while the weight is adjusting. Do not move the Kettlebell Connect™ while it is adjusting.
- The Kettlebell Connect™ will beep once when ready for use.

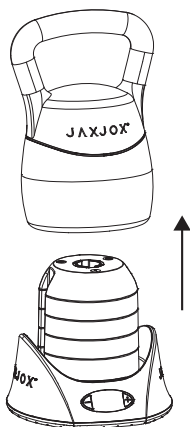

Lift the kettlebell shell from the base

- Wait for the single beep before moving the kettlebell shell.

IMPORTANT: Always lift the kettlebell shell straight up and clear the weights and base before attempting to use it. Not doing so may result in serious injury.

Workout with the kettlebell

- Before starting your workout, ensure your environment is free of anything that may interfere with your movements.
- Do not drop the kettlebell or use excessive force when moving the kettlebell.

IMPORTANT: Do not attempt to adjust any of the mechanisms on the underside of the kettlebell shell. Do not attempt to manually adjust the weight of the kettlebell shell. Doing so may result in serious injury and/or device malfunction.

Return the kettlebell shell to the base

- Avoid using excessive force when reseating the kettlebell shell into the base.
- Ensure the kettlebell shell and weights are aligned properly with the base when reseating. You should not need any additional force to reseat the kettlebell shell when all of the components are properly aligned.
- The kettlebell shell can be reseated with the JAXJOX® logo facing forwards or backwards.
- The Kettlebell Connect™ will beep once when properly seated.

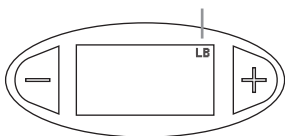

Change the unit of measurement

- Your chosen unit of measurement (LB or KG) appears in the top right corner of the screen.
- To change the unit of measurement between pounds and kilograms, *press both* – and + buttons at the same time and hold for two seconds.

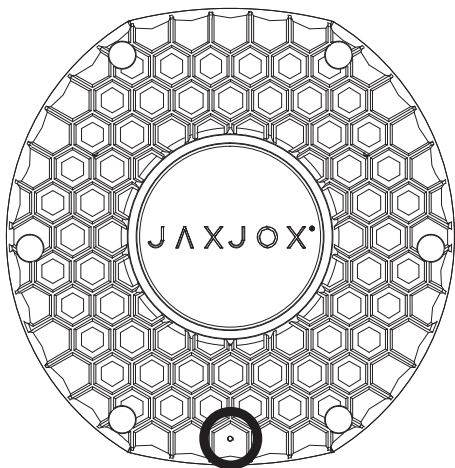

Reset the Kettlebell Connect™

- If you are experiencing issues with your Kettlebell Connect™, resetting the device may correct them.
- To reset the Kettlebell Connect™, press the reset button on the underside of the base, highlighted in the diagram.

Troubleshooting

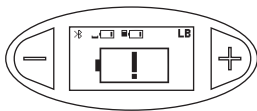

Low battery

- Charge the Kettlebell Connect™.
- Verify that the charging cable is fully inserted into the base and the AC adapter.
- Verify the AC adapter is plugged into a functioning power outlet.

connection



no connection



Bluetooth not connecting

- Verify the Kettlebell Connect™ has been added in the JAXJOX® app.
- Verify bluetooth is enabled on your mobile device.
- Follow the instructions in the *Get Started with the JAXJOX® App* section.

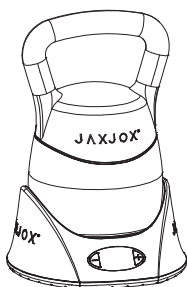

Kettlebell Connect™ is not adjusting weight

- Ensure the kettlebell shell is properly seated before adjusting the weight. The Kettlebell Connect™ will beep when seated correctly.
- Verify the weights are stacked correctly in the right order. Follow the instructions in the *Assembly* section.
- The weight of the kettlebell shell may be misaligned with the weight on the base. Follow the instructions below in *The weight on the kettlebell shell is not matched to the weight on the base* section.

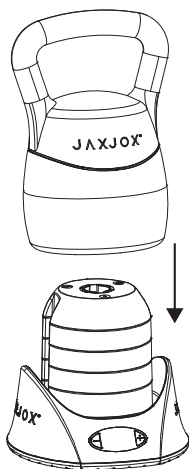

Kettlebell Connect™ is not beeping when reseating the kettlebell shell onto the base

- When reseating the kettlebell shell, ensure it is aligned correctly with the base. The handles should align with the wings on the base.
- Ensure the kettlebell shell is fully seated completely. It should sit fully against the base, without space in between.
- Verify the weights are stacked correctly in the right order. Follow the instructions in the *Assembly* section.
- The weight of the kettlebell shell may be misaligned with the weight on the base. Follow the instructions below in *The weight on the kettlebell shell is not matched to the weight on the base* section.

The weight on the kettlebell shell is not matched to the weight on the base.

- **WARNING:** Manually adjusting the weight of the kettlebell shell may cause serious injury or damage to the device. It may also cause a mismatch between the weight of the kettlebell shell and the base, causing the device to become inoperable. In this event, follow all safety precautions noted before attempting to fix the issue.
- **IMPORTANT:** Perform these actions low to the ground and keep all body parts out of the direct path of the kettlebell weights.
- Weight mismatch can be corrected by manually removing the weights in the kettlebell shell and adjusting the shaft to the correct position.
- Flip the kettlebell shell upside down so you are viewing the underside of the kettlebell shell.
- Locate the shaft in the center of the kettlebell shell. Press the locking pin and turn the shaft counter-clockwise.
- **IMPORTANT:** Pressing the locking pin will unlock any weights inside the kettlebell shell, and may result in serious injury if allowed to fall. Slowly rotate the kettlebell shell right side up, keeping one hand on the weights inside to slowly lower them out of the kettlebell shell and onto the ground.

- With the all weights removed from the kettlebell shell, press the locking pin and turn the shaft counter-clockwise until the teeth are aligned with the middle of the kettlebell shell, as illustrated in the diagram.

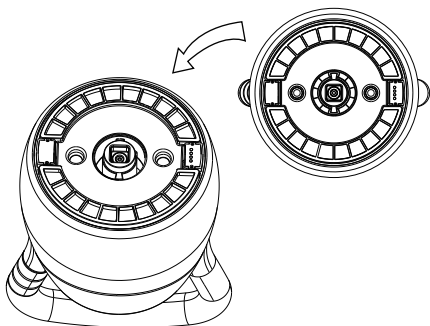

- Return the weights to the base in the right order. Follow the instructions in the *Assembly* section.
- Ensure the weight on the base is set to 12 lbs (5.4 kgs).
- Return the kettlebell shell to the base. The Kettlebell Connect™ should now operate correctly.

Safety warnings

The Kettlebell Connect™ is very heavy – we recommend placing it on the floor to minimize risk of injury. Before starting your workout, ensure your environment is free of anything that may interfere with your movements.

When moving the Kettlebell Connect™, disassemble all of the parts and reassemble them in the new location. Do not attempt to move the entire unit at one time.

Consult your physician before starting a workout plan. If you experience faintness, pain, or shortness of breath, stop exercising immediately and consult a physician.

Select a weight and perform a workout that is appropriate for your fitness level.

The Kettlebell Connect™ is not a toy. Do not allow children or pets to play with or around the device. Supervise and provide instruction to anyone under the age of 18 using the device.

Ensure weights are properly seated in the correct order. Ensure kettlebell shell is properly seated in the base (the Kettlebell Connect™ will beep once) before adjusting the weight.

Avoid using excessive force when reseating the kettlebell shell into the base. Ensure the kettlebell shell and weights are aligned properly with the base when reseating. It should not require any additional force when all of the components are properly aligned.

Do not drop the kettlebell or use excessive force when using the kettlebell. Do not move the Kettlebell Connect™ while the weight is being adjusted. Always lift the kettlebell shell straight up and clear the weights before attempting to use it. Do not attempt to adjust any of the mechanisms on the underside of the kettlebell shell. Do not attempt to manually adjust the weight of the kettlebell shell.

The Kettlebell Connect™ is for indoor use only. Avoid using it near water, or in high humidity areas such as a sauna or steam room.

Prior to cleaning, unplug the Kettlebell Connect™. To clean the kettlebell shell, use a dry or slightly damp cloth. Avoid using detergents. Avoid water coming in contact with the base, as it contains sensitive electronics.

Satisfaction guarantee

If you are not satisfied with your JAXJOX® Kettlebell Connect™ (hereafter referred to as the “Product”) for any reason, you have 30 days from the date of purchase to request a full refund.

To qualify for a refund, the following conditions must be met:

- You must contact JAXJOX® within 30 days of your purchase date.
- You must return the Product to JAXJOX® to receive a refund. Returned Product(s) must be in good physical condition (not broken or damaged). All components originally included with your purchase must be included with your return.

Shipping and handling charges, gift wrap fees, and taxes paid (such as state, customs, or VAT) are not refundable. You are responsible for all shipping charges and you assume the risk of loss or damage to the returned Product(s) while in transit back to JAXJOX®.

Limited warranty

JAXJOX® warrants to the original purchaser that your Kettlebell Connect™ (hereafter referred to as the “Product”) shall be free from defects in materials and workmanship under normal use for a period of one (1) year from the date of purchase.

If such a defect arises and a request is received by JAXJOX® within the applicable Warranty Period, JAXJOX® will, at its option and to the extent permitted by law, either (1) repair the Product at no charge, using new or refurbished replacement parts or (2) replace the Product with a new or refurbished Product. In the event of such a defect, to the extent permitted by law, these are your sole and exclusive remedies. Shipping and handling charges may apply except where prohibited by applicable law. This Limited Product Warranty is valid only in the jurisdictions where the Products are sold by JAXJOX® itself or through its authorized reseller or agent and is valid to the extent permitted by the applicable laws of such jurisdictions. Any replacement Product will be warranted for the remainder of the original warranty period or thirty (30) days, whichever is longer, or for any additional period of time that may be required by applicable law.

How to obtain warranty service

To be eligible for service under this Limited Warranty you must contact JAXJOX®. As may be required by applicable law, JAXJOX® may require you to furnish proof of purchase details and/or comply with other requirements before receiving warranty service.

Claims must be made within the specified warranty period.

Questions or concerns

JAXJOX® stands behind the quality of our products. We hope that our beautifully designed, interconnected fitness products and accessories meet your needs and get you where you want to be. If you need assistance or are experiencing issues with your product, please contact us for help and answers.



For customer services enquiries:

customer.services@jaxjox.com

For general enquires:

help@jaxjox.com



(425) 324-3017

(changes or modifications not expressly approved by the party responsible for compliance could void the user's authority to operate the equipment)

Notices

This device complies with part 15 of the FCC Rules. Operation is subject to the following two conditions: (1) this device must not cause harmful interference, and (2) this device must not accept any interference received, including interference that may cause undesired operation.

Note: This equipment has been tested and found to comply with the limits for a Class B digital device, pursuant to Part 15 of the FCC Rules. These limits are designed to provide reasonable protection against harmful interference in a residential installation. This equipment generates, uses and can radiate radio frequency energy and, if not installed and used in accordance with the instructions, may cause harmful interference to radio communications. However, there is no guarantee that interference will not occur in a particular installation. If this equipment does cause harmful interference to radio or television reception, which can be determined by turning the equipment off and on, the user is encouraged to try to correct the interference by one or more of the following measures:

- Reorient or relocate the receiving antenna.
- Increase the separation between the equipment and receiver.
- Connect the equipment into an outlet on a circuit different from that to which the receiver is connected.
- Consult the dealer or an experienced radio/TV technician for help. This device meets the FCC requirements for RF exposure in public or uncontrolled environments.

Waste electrical products should not be disposed of with household waste. Please recycle where facilities exist. Contact your local government or a retailer for additional information.

JAXJOX®