

## EUT Test Setup

### 8.1 Block Diagram

The following diagram shows basic EUT interconnections with cable type and cable lengths identified:

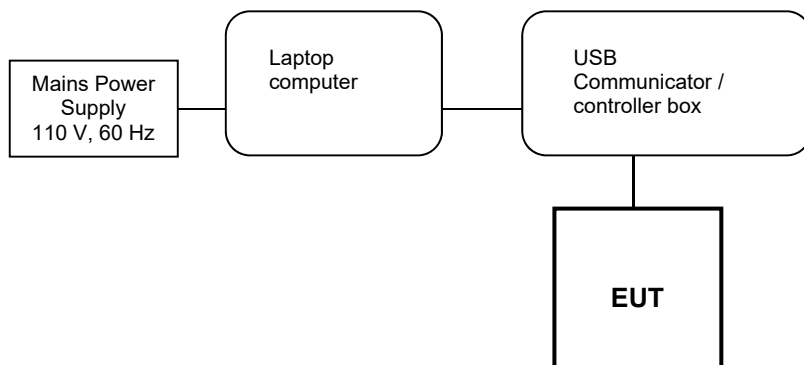

## 8.2 General Set-up Photograph

The following photograph shows basic EUT set-up:



### 10.4 Test Method

With the EUT setup as per section 9 of this report and connected as per Figure i, the emissions from the EUT were measured on a spectrum analyzer / EMI receiver.

Radiated electromagnetic emissions from the EUT are checked first by preview scans. Preview scans for all spectrum and modulation characteristics are checked, using a peak detector and where applicable worst-case determined for function, operation, orientation, etc. for both vertical and horizontal polarisations. Pre-scan plots are shown with a peak detector and 100 kHz RBW.

If the EUT connects to auxiliary equipment and is table or floor standing, the configurations prescribed in ANSI C63.10 are followed. Alternatively, a layout closest to normal use (as declared by the provider) is employed, (see EUT setup photographs for more detail).

Emissions between 30 MHz and 1 GHz are measured using calibrated broadband antennas. Emissions above 1 GHz are characterized using standard gain horn antennas. Pre-amplifiers and filters are used where required. Care is taken to ensure that test receiver resolution bandwidth, video bandwidth and detector type(s) meet the regulatory requirements.

For both horizontal and vertical polarizations, the EUT is then rotated through 360 degrees in azimuth until the highest emission is detected. At the previously determined azimuth the test antenna is raised and lowered from 1 to 4 m in height until a maximum emission level is detected, this maximum value is recorded.

Power values measured on the test receiver / analyzer are converted to field strength, FS, in dBµV/m at the regulatory distance, using:

$$FS = PR + CL + AF - PA + DC - CF$$

Where,

- PR is the power recorded on the receiver / spectrum analyzer in dBµV;
- CL is the cable loss in dB;
- AF is the test antenna factor in dB/m;
- PA is the pre-amplifier gain in dB (where used);
- DC is the duty correction factor in dB (where used, e.g. harmonics of pulsed fundamental);
- CF is the distance factor in dB (where measurement distance different to limit distance);

This field strength value is then compared with the regulatory limit.

**Figure i Test Setup**

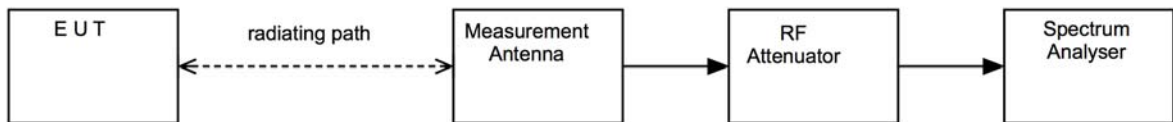

### 10.5 Test Set-up Photograph



### 10.6 Test Equipment

Equipment Type	Manufacturer	Equipment Description	Element No	Due For Calibration
FSU50	R&S	Spectrum Analyser	U544	27/04/2018
310	Sonoma	Pre-Amp (9kHz – 1GHz)	REF927	30/06/2018
8449B	Agilent	Pre-Amp (1 – 26.5GHz)	REF913	02/02/2018
Cable	AtlanTec	Short SMA RF Cable	REF2165	09/12/2017
Bandstop filter	Unknown	2.4 GHz ISM bandstop filter	REF2158	Cal before use
Cable	Teleydyne	K-Type RF coaxial cable	REF2184	27/03/2018
Cable	Teleydyne	K-Type RF coaxial cable	REF2185	27/03/2018
3115	EMCO	Horn Antenna	RFG129	09/02/2018
3146	EMCO	Log Periodic Antenna	RFG191	17/05/2019
Antenna	Q-Par	Horn Antenna	RFG630	24/11/2017
3109	EMCO	Biconical Antenna	RFG095	17/05/2019

**11.4 Test Method**

With the EUT setup in a screened room, as per section 9 of this report and connected as per Figure ii, the power line emissions were measured on a spectrum analyzer / EMI receiver.

AC power line conducted emissions from the EUT are checked first by preview scans with peak and average detectors covering both live and neutral lines. A spectrum analyzer is used to determine if any periodic emissions are present.

Formal measurements using the correct detector(s) and bandwidth are made on frequencies identified from the preview scans. Final measurements were performed with EUT set at its maximum duty in transmit and receive modes.

**Figure ii Test Setup**

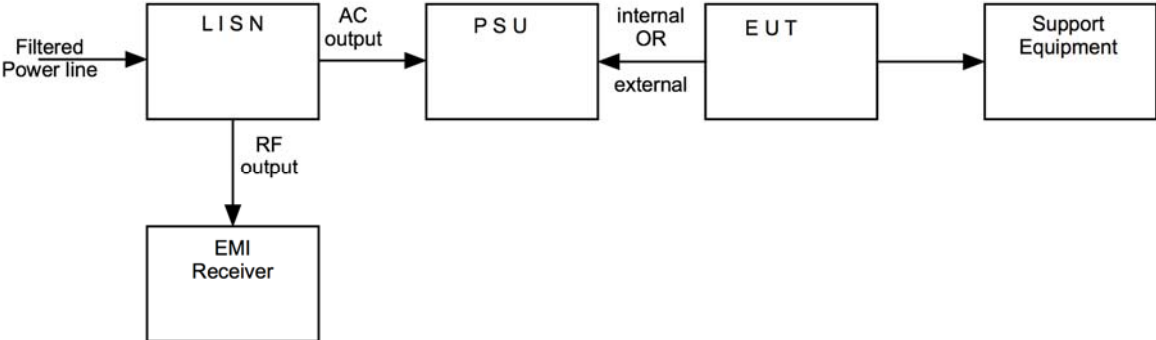

### 11.5 Test Set-up Photograph



### 11.6 Test Equipment

Equipment Type	Manufacturer	Equipment Description	Element No	Due For Calibration
LISN	R&S	ESH3-Z5	H189	7/8/2018
Pulse Limiter	R&S	ESH3-Z2	H674	6/4/2018
RF Chamber (Line Conducted Site)	Belling Lee	Lab 5	H705	N / A
Analyser/Receiver	R&S	ESCI 7	H715	11/10/2017
Vertical Ground Reference Plane	Element	2.5m x 2m	H737	N / A