

TEST REPORT

**STANDARD : FCC Part15C
RSS-210 Issue 9**

Applicant	Testing Laboratory
AIPHONE Co., LTD 2-18, Jinno-cho, Atsuta-ku, Nagoya 456-8666, JAPAN Tel: +81 52 681 8721	Intertek Japan K.K. Nagano Laboratory URL: http://www.japan.intertek-etlsemko.com 3226 Yokokawa, Tatsuno-machi, Kamiina-gun, Nagano 399-0511 Japan Tel. +81 266 47 5311

Equipment Type	Entrance station (Integrated Type)
Trademark	AIPHONE
Model(s)	GT-DMB-LVN / GT-DMB-N
Serial No.	0000169R(J725-2436)
Equipment Authorization	Certification
FCC ID	2ALNEGTDMBN
ISED CN and UPN	4361A-GTDMBN
Test Result	Complied
Report Number	17010363JNA-003
Original Issue Date	June 5, 2017
Revised Issue Date	June 14, 2017

This report is for the exclusive use of Intertek's Client and is provided pursuant to the agreement between Intertek and its Client. Intertek's responsibility and liability are limited to the terms and conditions of the agreement. Intertek assumes no liability to any party, other than to the Client in accordance with the agreement, for any loss, expense or damage occasioned by the use of this report. Only the Client is authorized to permit copying or distribution of this report and then only in its entirety. Any use of the Intertek name or one of its marks for the sale or advertisement of the tested material, product or service must first be approved in writing by Intertek. The observations and test results in this report are relevant only to the sample tested. This report by itself does not imply that the material, product, or service is or has ever been under an Intertek certification program.

Approved by



Hideaki Kosemura
[Technical Manager]

Tested by

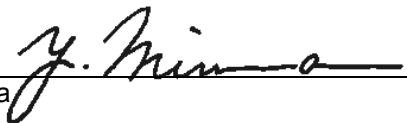

Yoshihide Mimura
[Test Engineer]

Responsible Party of Test Item (Product)

Responsible Party	:
Add.	:
Tel.	:
Fax.	:
Contact Person	:

TABLE OF CONTENTS

	Page
SECTION 1. GENERAL INFORMATION	3
SECTION 2. SUMMARY OF TEST RESULTS	4
SECTION 3. EQUIPMENT UNDER TEST	5
SECTION 4. SUPPORT EQUIPMENT.....	6
SECTION 5. USED CABLE(S).....	7
SECTION 6. TEST CONFIGURATION	8
SECTION 7. OPERATING CONDITION	9
SECTION 8. UNCERTAINTY	10
SECTION 9. EVALUATION OF TEST RESULTS	11
SECTION 10. LIST OF MEASURING INSTRUMENTS.....	30
ANNEX	32
APPENDIX PHOTOGRAPHS OF MAXIMUM EMISSION SET-UP	

FCC ID : 2ALNEGTDMBN
 ISED CN and UPN :4361A-GTDMBN

SECTION 1. GENERAL INFORMATION

Test Performed

EUT Received	February 14, 2017
Date of Test	From February 14, 2017 to March 17, 2017
Standard Applied	FCC Part15C RSS-210 Issue 9
Test methods	ANSI C63.10-2013
Deviation from Standard(s)	None

Qualifications of Testing Laboratory

Accreditation	Scope	Lab. Code	Remarks
VLAC	EMC Testing	VLAC-008-4	JAPAN
BSMI	EMC Testing	SL2-IN-E-6007	TAIWAN
Filing			
VCCI	EMC Testing	A-0128	JAPAN
FCC	EMC Testing	JP0010	USA
IC	EMC Testing	2042O-1	CANADA

Abbreviations

EUT	Equipment Under Test	DoC	Declaration of Conformity
AMN	Artificial Mains Network	ISN	Impedance Stabilization Network
LISN	Line Impedance Stabilization Network	Q-P	Quasi-peak
AMP	Amplifier	AVG	Average
ATT	Attenuator	PK	Peak
ANT	Antenna	Cal	Calibration
BBA	Broadband Antenna	N/A	Not applicable or Not available
DIP	Dipole Antenna	LCD	Liquid-Crystal Display
AE	Associated Equipment	HDMI	High-Definition Multimedia Interface
OBW	Occupied Bandwidth		

Revision Summary

Revised Date	Section	Description of Changes
June 14, 2017	3	3.4 Add Remarks
June 14, 2017	3	The Overview of EUT has been deleted.
June 14, 2017	7	The operation explanation has been added.
June 14, 2017	9	Page 14 Modification of the figures and tables
June 14, 2017	10	Add Measuring Instruments
June 14, 2017	ANNEX	Page 33, 34 Modification of the figures

FCC ID : 2ALNEGTDMBN
ISED CN and UPN :4361A-GTDMBN**SECTION 2. SUMMARY OF TEST RESULTS**

See Section9 for the detailed result.

Emission Tests

Standard Applied		FCC Part15C (15.207, 15.225, 15.209) RSS-210 Issue 9 (B.6)
Test Item	Minimum margin	Remarks
Conducted disturbance at mains terminals	24.3 dB (0.1564 MHz) [Q-P]	
Radiated disturbance (IN band)	52.3 dB (13.5670 MHz)	
Radiated disturbance (OUT band)	13.1 dB (800.04 MHz)	

Standard Applied		FCC Part15C (15.225) RSS-210 Issue 9 (B.6)
Test Item	Result	Remarks
Frequency Tolerance	PASS	

Standard Applied		FCC Part15C(15.215(c)) RSS-Gen Issue 4 (6.6)
Test Item	Result	Remarks
20dB OBW 99%OBW	N/A	See Note

Note : None Limit (for reporting purposes only)

FCC ID : 2ALNEGTDMBN
 ISED CN and UPN :4361A-GTDMBN

SECTION 3. EQUIPMENT UNDER TEST

The equipment under test (EUT) consisted of the following apparatus.

3.1 System Configuration

Symbol	Item	Model No.	Serial No.	Manufacturer	Remarks
A1	Entrance station (Integrated Type)	GT-DMB-LVN	0000169R(J725-2436)	AIPHONE Co., LTD	-
Rated Power : 100V-240 V, 50-60 Hz, 1.2-0.65 A					
Supplied Power : AC 120V, 60Hz					
Condition of Equipment		PreProduction			
Type		Wall hanging type			
Suppression Devices		No Modifications by the laboratory were made to the device			

3.2 Port(s)/Connector(s)

Port Name	Connector Type	Connector Pin	Remarks
R1R2	-	2 pin	-
A1A2	-	2 pin	-
B1B2	-	2 pin	-

3.3 Highest Frequency Generated / Used

Operating Frequency	Operating mode	Remarks
266.66 MHz	Confirmation of NFC reader	CPU (SH 7269) Internal operating frequency

3.4 Variation of Model(s)

Model No.	Remarks
GT-DMB-LVN	Tested model
GT-DMB-N	Family model

Note :

Compared to GT-DMB-LVN, GT-DMB-N has no magnetic loop for hearing aid T-mode, and no hole on the panel where a third party key cylinder not electrically connected with the EUT is attached.

3.5 RFID module specification

Model No.	ARI3030I
Operating Frequency	13.56 MHz
Number of Channel	1 ch
Modulation Technology	ISO/IEC 14443 Type A / MIFARE ISO/IEC 14443 Type A / MIFARE: Manchester coding MIFARE Higher Baud Rate: BPSK ISO/IEC 14443 Type B / BPSK ISO/IEC 18092 FeliCa: Manchester coding
Transfer rate	MIFARE: 106 kbps FeliCa: 212 kbps / 424 kbps
TX Power	Max. 20dBm (less than 100m W)

FCC ID : 2ALNEGTDMBN
ISED CN and UPN :4361A-GTDMBN**SECTION 4. SUPPORT EQUIPMENT**

The EUT was supported by the following equipment during the test.

Symbol	Item	Model No.	Serial No.	Manufacturer	FCC ID
B	Power supply	PS-2420	1536(J725-967)	AIPHONE Co., LTD	N/A
Supplied Power:					
B	AC120 V, 60 Hz				

SECTION 5. USED CABLE(S)

The following cable(s) was used for the test.

No.	Name	Length (m)	Shield	Metal Connector	Ferrite Core
1	Signal cable	2.00	No	No	
2	AC power cable for PS2420	1.90	No	No	
3	FG cable	2.00	No	No	

Note :

1. No ferrite core is attached to the outer cables.

SECTION 6. TEST CONFIGURATION

6.1 Conducted disturbance at mains terminals Tests and Radiated disturbance tests

* : EUT

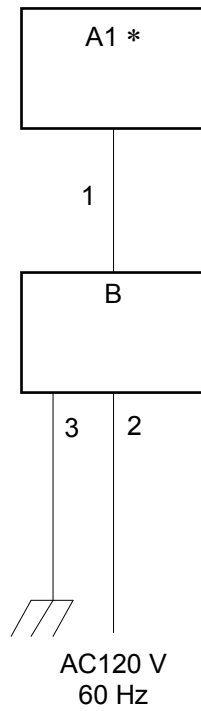

The symbols and numbers assigned to the equipments and cables on this diagram correspond to the ones in Sections 3 to 5.

SECTION 7. OPERATING CONDITION

The test was carried out under the following mode.
This operation mode is the worst.

7.1 Confirmation of NFC reader mode (Reader/Writer emulation and Card emulation)

Cycle time for operation: 500 ms

MIFARE: 106 kbps Modified Miller ASK 100%
FeliCa: 212 kbps Manchester coding ASK 10%
FeliCa: 424 kbps Manchester coding ASK 10%

The above-mentioned, movement consecutive in a period in about 500ms,
with above 3 modulation, Polling (reader state) and Card emulation (tag state)
while being irregular.

FCC ID : 2ALNEGTDMBN
ISED CN and UPN :4361A-GTDMBN**SECTION 8. UNCERTAINTY**

Traceability to national standard in SI units is ensured with these values.
Compliance with the limits in this standard are determined without in consideration of the measurement uncertainty of the measurement instrumentation.

8.1 Emission tests

Radiated disturbance at 3m	$U_{lab} [k = 2]$	U_{cispr}
30 MHz – 1000 MHz	+/- 4.28 dB	6.3 dB
Above 1 GHz	+/- 4.80 dB	5.2 dB
Radiated disturbance at 10m		
30 MHz – 1000 MHz	+/- 4.81 dB	6.3 dB
Radiated disturbance at 30m		
	N/A	Nil
Conducted disturbance at mains terminals		
9 kHz – 150 kHz	+/- 1.77 dB	3.8 dB
150 kHz – 30 MHz		3.4 dB
Conducted disturbance at telecommunication ports (ISN)		
150 kHz – 30 MHz	+/- 3.11 dB	5.0 dB
Conducted disturbance at telecommunication ports (Capacitive Voltage Probe)		
150 kHz – 30 MHz	+/- 3.06 dB	3.9 dB
Conducted disturbance at telecommunication ports (Current Probe)		
150 kHz – 30 MHz	+/- 1.89 dB	2.9 dB
Conducted disturbance at terminals		
150 kHz – 30 MHz	+/- 1.77 dB	2.9 dB
Disturbance power		
30 MHz – 300 MHz	+/- 2.49 dB	4.5 dB

The above expanded instrumentation uncertainty, U_{lab} , is estimated in accordance with CISPR 16-4-2:2011.

SECTION 9. EVALUATION OF TEST RESULTS**9.1 Emission tests****9.1.1 Conducted disturbance at mains terminals**

Location	Nagano No.3 Test Site
Test Engineer	Yoshihide Mimura

Frequency Range of Measurements

Required Measurement Frequency Range	Measured Frequency Range
0.15 – 30 MHz	0.15 – 30 MHz

Test Procedure

Item	Document number
Conducted disturbance at mains terminals	LEN-RJP-TE003

Setting for the Measuring instruments

Instrument	Detector	Resolution Bandwidth	Video Bandwidth
Receiver	Quasi Peak	10 kHz	N/A
	Average	10 kHz	N/A

< Measurement data correction >

Emission Level = Meter Reading + Factor

Margin = Limit- Emission Level

Factor = LISN Factor + Cable Loss + Attenuator

< Sample Calculations >

Sample @0.1564 MHz (Confirmation of NFC reader mode)

Emission Level = 31.2 [dBuV] + 10.1 [dB] = 41.3 [dBuV]

FCC ID : 2ALNEGTDMBN
 ISED CN and UPN :4361A-GTDMBN

Result of Conducted disturbance at mains terminals

Intertek Japan K.K.
Nagano No.3 Test Site
 AC Conducted Emission Test

APPLICANT : AIPHONE Co., LTD
 EUT NAME : Entrance station (Integrated Type)
 MODEL NO. : GT-DMB-LVN
 SERIAL NO. : 0000169R(J725-2436)
 TEST MODE : Confirmation of NFC reader
 POWER SOURCE : AC120 V, 60 Hz
 DATE TESTED : Feb 15 2017
 FILE NO. : -
 REGULATION : FCC part15C (15.207)
 TEST METHOD : ANSI C63.10-2013
 TEMPERATURE : 22.5 [degC]
 HUMIDITY : 38.0 [%]
 NOTE : AC Adapter:PS-240(1536J725-974)

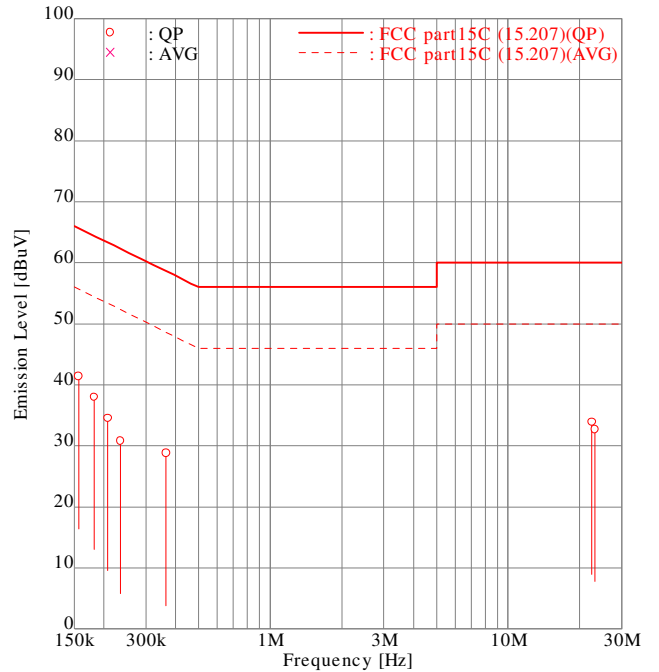

ENGINEER : Yoshhide Mimura

FREQUENCY [No]	MODE [MHz]		READING [dBuV]		FACTOR [dB]		EMISSION [dBuV]		LIMIT [dBuV]	MARGIN [dB]	
			Line1	Line2	Line1	Line2	Line1	Line2		Line1	Line2
1	0.1564	QP	31.2	<u>31.2</u>	10.1	10.2	41.3	<u>41.4</u>	65.7	24.4	<u>24.3</u>
2	0.1823	QP	27.8	<u>27.8</u>	10.1	10.2	37.9	<u>38.0</u>	64.4	26.5	<u>26.4</u>
3	0.2077	QP	24.1	<u>24.3</u>	10.1	10.2	34.2	<u>34.5</u>	63.3	29.1	<u>28.8</u>
4	0.2342	QP	20.3	<u>20.6</u>	10.1	10.2	30.4	<u>30.8</u>	62.3	31.9	<u>31.5</u>
5	0.3653	QP	18.5	<u>18.6</u>	10.2	10.2	28.7	<u>28.8</u>	58.6	29.9	<u>29.8</u>
6	22.4851	QP	22.3	<u>23.1</u>	10.8	10.8	33.1	<u>33.9</u>	60.0	26.9	<u>26.1</u>
7	23.1589	QP	21.5	<u>21.9</u>	10.8	10.8	32.3	<u>32.7</u>	60.0	27.7	<u>27.3</u>

Higher six points are underlined.
 Other frequencies : Below the FCC part15C (15.207) limit
 Emission Level = Read + Factor(LISN,Pad,Cable)

9.1.2 Radiated disturbance (IN band and OUT band)

Location	Nagano No.3 Test Site
Test Engineer	Yoshihide Mimura

Frequency Range of Measurements

Operating mode	Required Frequency Range	Measured Frequency Range
Confirmation of NFC reader	0.0090 – 2000 MHz	0.0090 – 2000 MHz

Test Procedure

Item	Document number
Radiated disturbance	LEN-RJP-TE003

Setting for the Measuring instruments

Frequency [MHz]	Instrument	Detector	Resolution Bandwidth	Video Bandwidth
0.009 - 30	Receiver	AVG : 0.009 - 0.090 MHz QP : 0.090 - 0.110 MHz AVG : 0.110 - 0.490 MHz QP : 0.490 - 30 MHz	200 Hz : 0.009 - 0.15 MHz 10 kHz : 0.15 – 30 MHz	N/A
30 – 1000	Receiver	Quasi Peak	120 kHz	N/A
Above 1000	Receiver	Peak	1 MHz	N/A
		Average	1 MHz	N/A

< Measurement data correction >

Emission Level = Meter Reading + Factor

Margin = Limit - Emission Level

Factor = Antenna Factor + Cable Loss - Amplifier Gain + Attenuator (+ Distance Conversion Factor)*

* For other than Standard distance:

Distance Conversion Factor = 20 log (Measurement distance / Standard distance)

< Sample Calculations >

Sample @94.92 MHz (Confirmation of NFC reader mode)

Emission Level = 32.0 [dBuV] - 13.4 [dB/m] = 18.6 [dBuV/m]

Operating Condition	EUT Axis	EUT Volume	Frequency Range	Measurement distance
Confirmation of NFC reader mode	X, Y, Z	-	0.009 -1000 MHz	3.00 m
	X	1.04 m	Above 1 GHz	3.88 m
	Y	1.04 m		3.88 m
	Z	1.16 m		3.82 m

Absorber placement and Receive Antenna location in Radiated disturbance above 1 GHz

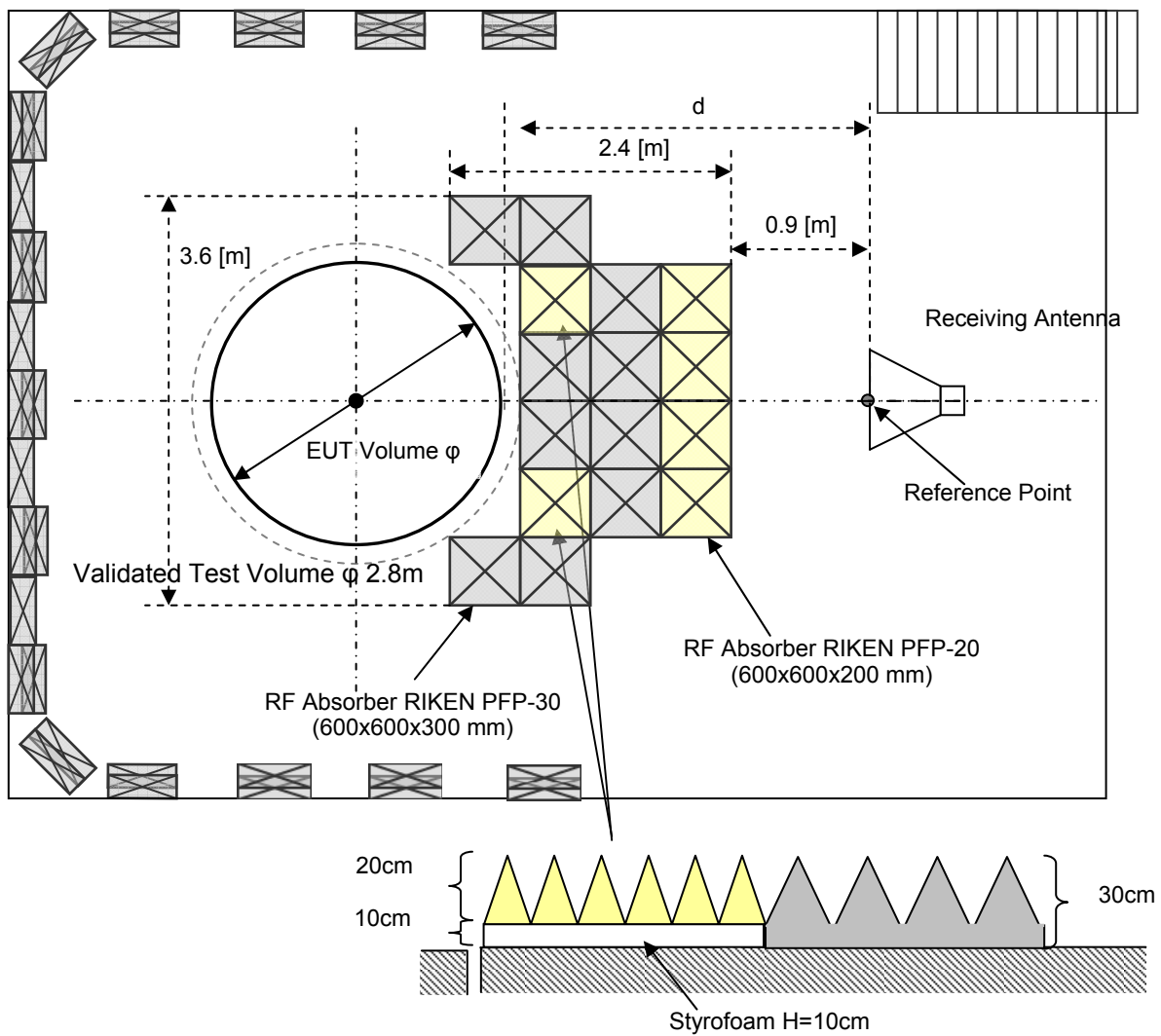

FCC ID : 2ALNEGTDMBN
 ISED CN and UPN :4361A-GTDMBN

Result of Radiated disturbances

9.1.2.1 IN band (X axis)

Intertek Japan K.K.
Nagano No.3 Test Site
 Field Strength Emission Test

APPLICANT : AIPHONE Co., LTD
 EUT NAME : Entrance station (Integrated Type)
 MODEL NO. : GT-DMB-LVN
 SERIAL NO. : 0000169R(J725-2436)
 TEST MODE : Confirmation of NFC reader
 POWER SOURCE : AC120 V, 60 Hz
 DATE TESTED : Mar 17 2017
 FILE NO. : -
 REGULATION : FCC part15C (15.225)
 TEST METHOD : ANSI C63.10 :2013
 DISTANCE : 3.00 [m]
 TEMPERATURE : 31.4 [degC]
 HUMIDITY : 37.0 [%]
 NOTE : X

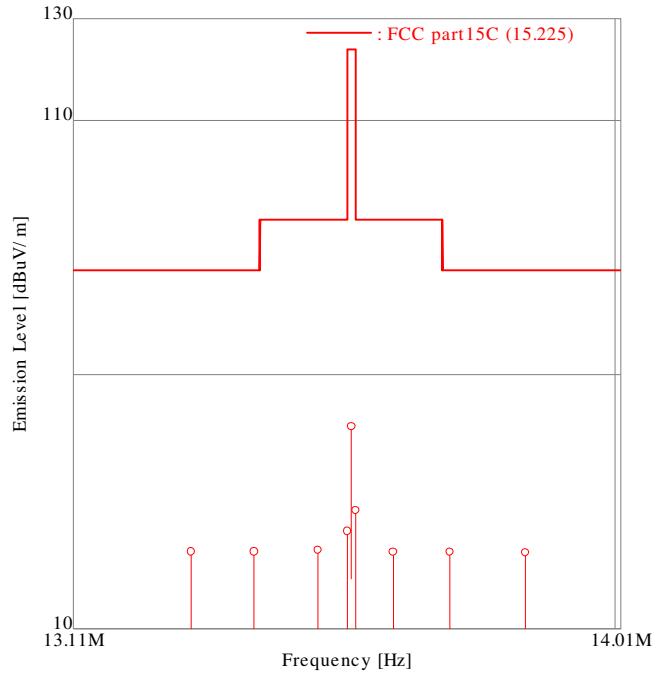

ENGINEER : Yoshihide Mimura

FREQUENCY [No]	FREQUENCY [MHz]	READING [dBuV]		FACTOR [dB]		EMISSION [dBuV/m]		LIMIT [dBuV/m]		MARGIN [dB]	
		Hori	Vert	Hori	Vert	Hori	Vert	Hori	Vert	Hori	Vert
1	13.2990	<u>24.5</u>	24.2	0.7	0.7	<u>25.2</u>	24.9	80.5		<u>55.3</u>	55.6
2	13.4011	<u>24.5</u>	24.4	0.7	0.7	<u>25.2</u>	25.1	80.5		<u>55.3</u>	55.4
3	13.5047	<u>24.8</u>	24.5	0.7	0.7	<u>25.5</u>	25.2	90.5		<u>65.0</u>	65.3
4	13.5530	<u>28.5</u>	27.2	0.7	0.7	<u>29.2</u>	27.9	90.5		<u>61.3</u>	62.6
5	13.5600	49.1	46.6	0.7	0.7	49.8	47.3	124.0		74.2	76.7
6	13.5670	<u>32.6</u>	30.7	0.7	0.7	<u>33.3</u>	31.4	90.5		<u>57.2</u>	59.1
7	13.6290	<u>24.3</u>	24.4	0.7	0.7	<u>25.0</u>	25.1	90.5		<u>65.5</u>	65.4
8	13.7224	<u>24.4</u>	24.2	0.7	0.7	<u>25.1</u>	24.9	80.5		<u>55.4</u>	55.6
9	13.8491	<u>24.3</u>	24.2	0.7	0.7	<u>25.0</u>	24.9	80.5		<u>55.5</u>	55.6

Higher six points are underlined.
 Other frequencies : Below the FCC part15C (15.225) limit
 Emission Level = Read + Factor(Antenna, Antenna Pad, Cable, Preamp)

FCC ID : 2ALNEGTDMBN
 ISED CN and UPN :4361A-GTDMBN

9.1.2.2 IN band (Y axis)

Intertek Japan K.K.
Nagano No.3 Test Site
 Field Strength Emission Test

APPLICANT : AIPHONE Co., LTD
 EUT NAME : Entrance station (Integrated Type)
 MODEL NO. : GT-DMB-LVN
 SERIAL NO. : 0000169R(J725-2436)
 TEST MODE : Confirmation of NFC reader
 POWER SOURCE : AC120 V, 60 Hz
 DATE TESTED : Mar 17 2017
 FILE NO. : -
 REGULATION : FCC part15C (15.225)
 TEST METHOD : ANSI C63.10 :2013
 DISTANCE : 3.00 [m]
 TEMPERATURE : 31.4 [degC]
 HUMIDITY : 37.0 [%]
 NOTE : Y

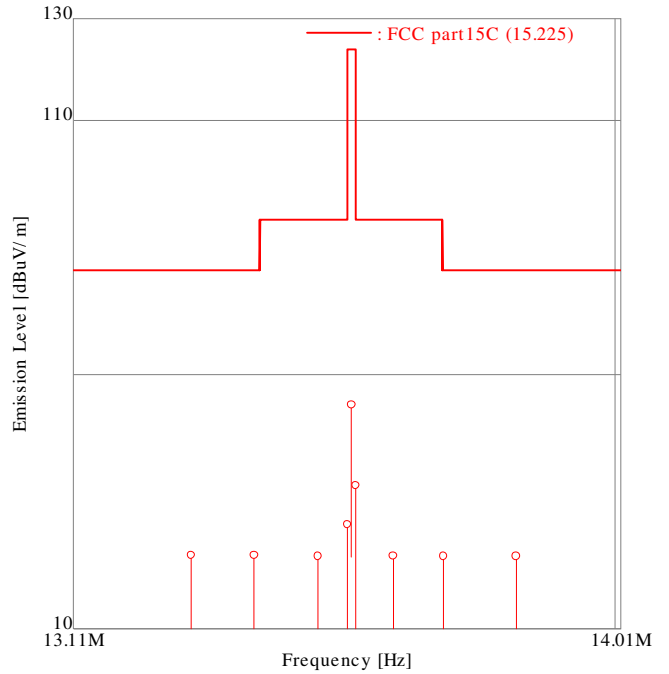

ENGINEER : Yoshihide Mimura

FREQUENCY [No]	FREQUENCY [MHz]	READING [dBuV]		FACTOR [dB]		EMISSION [dBuV/m]		LIMIT [dBuV/m]		MARGIN [dB]	
		Hori	Vert	Hori	Vert	Hori	Vert	Hori	Vert	Hori	Vert
1	13.2990	23.6	<u>23.8</u>	0.7	0.7	24.3	<u>24.5</u>	80.5	80.5	56.2	<u>56.0</u>
2	13.4011	<u>23.8</u>	23.5	0.7	0.7	<u>24.5</u>	24.2	80.5	80.5	<u>56.0</u>	56.3
3	13.5047	23.6	23.6	0.7	0.7	24.3	24.3	90.5	90.5	66.2	66.2
4	13.5530	<u>29.8</u>	24.8	0.7	0.7	<u>30.5</u>	25.5	90.5	90.5	<u>60.0</u>	65.0
5	13.5600	53.4	42.8	0.7	0.7	<u>54.1</u>	43.5	124.0	124.0	69.9	80.5
6	13.5670	<u>37.5</u>	29.1	0.7	0.7	<u>38.2</u>	29.8	90.5	90.5	<u>52.3</u>	60.7
7	13.6290	23.7	23.4	0.7	0.7	24.4	24.1	90.5	90.5	66.1	66.4
8	13.7122	<u>23.6</u>	23.4	0.7	0.7	<u>24.3</u>	24.1	80.5	80.5	<u>56.2</u>	56.4
9	13.8334	<u>23.6</u>	23.4	0.7	0.7	<u>24.3</u>	24.1	80.5	80.5	<u>56.2</u>	56.4

Higher six points are underlined.
 Other frequencies : Below the FCC part15C (15.225) limit
 Emission Level = Read + Factor(Antenna,Antenna Pad,Cable,Preamp)

FCC ID : 2ALNEGTDMBN
 ISED CN and UPN :4361A-GTDMBN

9.1.2.3 IN band (Z axis)

Intertek Japan K.K.
Nagano No.3 Test Site
 Field Strength Emission Test

APPLICANT : AIPHONE Co., LTD
 EUT NAME : Entrance station (Integrated Type)
 MODEL NO. : GT-DMB-LVN
 SERIAL NO. : 0000169R(J725-2436)
 TEST MODE : Confirmation of NFC reader
 POWER SOURCE : AC120 V, 60 Hz
 DATE TESTED : Mar 17 2017
 FILE NO. : -
 REGULATION : FCC part15C (15.225)
 TEST METHOD : ANSI C63.10 :2013
 DISTANCE : 3.00 [m]
 TEMPERATURE : 31.4 [degC]
 HUMIDITY : 37.0 [%]
 NOTE : Z

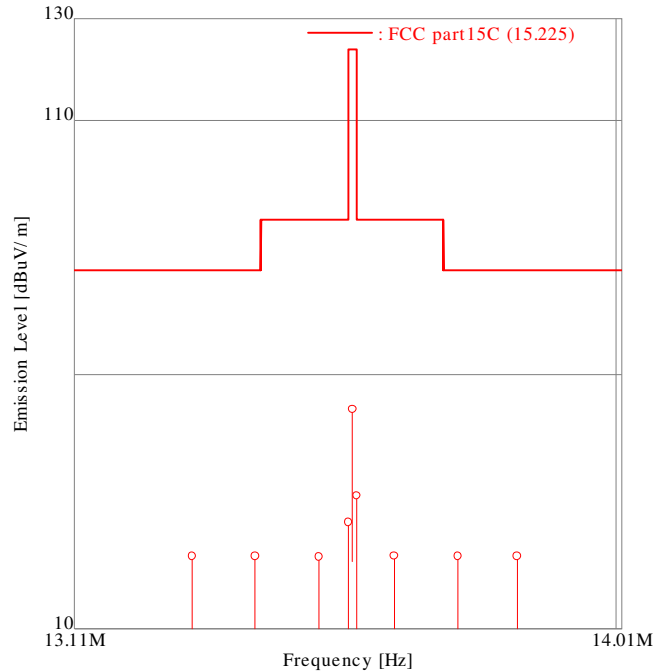

ENGINEER : Yoshihide Mimura

FREQUENCY [No]	FREQUENCY [MHz]	READING [dBuV]		FACTOR [dB]		EMISSION [dBuV/m]		LIMIT [dBuV/m]		MARGIN [dB]	
		Hori	Vert	Hori	Vert	Hori	Vert	Hori	Vert	Hori	Vert
1	13.2990	<u>23.6</u>	23.6	0.7	0.7	<u>24.3</u>	24.3	80.5	80.5	<u>56.2</u>	56.2
2	13.4011	<u>23.6</u>	23.5	0.7	0.7	<u>24.3</u>	24.2	80.5	80.5	<u>56.2</u>	56.3
3	13.5047	<u>23.5</u>	23.5	0.7	0.7	<u>24.2</u>	24.2	90.5	90.5	<u>66.3</u>	66.3
4	13.5530	<u>30.3</u>	27.8	0.7	0.7	<u>31.0</u>	28.5	90.5	90.5	<u>59.5</u>	62.0
5	13.5600	<u>52.5</u>	49.2	0.7	0.7	<u>53.2</u>	49.9	124.0	124.0	<u>70.8</u>	74.1
6	13.5670	<u>35.5</u>	33.8	0.7	0.7	<u>36.2</u>	34.5	90.5	90.5	<u>54.3</u>	56.0
7	13.6290	<u>23.7</u>	23.6	0.7	0.7	<u>24.4</u>	24.3	90.5	90.5	<u>66.1</u>	66.2
8	13.7346	<u>23.5</u>	<u>23.6</u>	0.7	0.7	<u>24.2</u>	<u>24.3</u>	80.5	80.5	<u>56.3</u>	<u>56.2</u>
9	13.8334	<u>23.6</u>	23.5	0.7	0.7	<u>24.3</u>	24.2	80.5	80.5	<u>56.2</u>	56.3

Higher six points are underlined.
 Other frequencies : Below the FCC part15C (15.225) limit
 Emission Level = Read + Factor(Antenna,Antenna Pad,Cable,Preamp)

FCC ID : 2ALNEGTDMBN
 ISED CN and UPN :4361A-GTDMBN

9.1.2.4 Out band
0.009 – 30 MHz (X axis)

Intertek Japan K.K.

Nagano No.3 Test Site

Spurious Emission - Radiated Test

APPLICANT : AIPHONE Co., LTD
 EUT NAME : Entrance station (Integrated Type)
 MODEL NO. : GT-DMB-LVN
 SERIAL NO. : 0000169R(J725-2436)
 TEST MODE : Confirmation of NFC reader
 POWER SOURCE : AC120 V, 60 Hz
 DATE TESTED : Feb 20 2017
 FILE NO. : -
 REGULATION : FCC part15C (15.209)
 TEST METHOD : ANSI C63.10-2013
 DISTANCE : 3.00 [m]
 TEMPERATURE : 18.0 [degC]
 HUMIDITY : 51.0 [%]
 NOTE : X

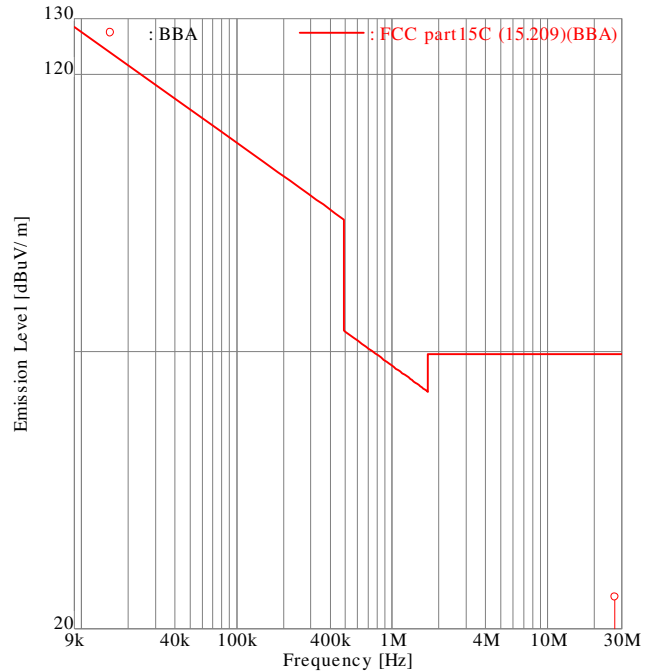

ENGINEER : Yoshihide Mimura

FREQUENCY [No]	FREQUENCY [MHz]	READING [dBuV]	FACTOR [dB]	EMISSION [dBuV/m]	LIMIT [dBuV/m]	MARGIN [dB]
1	27.1200	<u>24.2</u>	1.6	<u>25.8</u>	69.5	<u>43.7</u>

Higher six points are underlined.
 Other frequencies : Below the FCC part15C (15.209) limit
 Emission Level = Read + Factor(Antenna,Antenna Pad,Cable,Preamp)

FCC ID : 2ALNEGTDMBN
 ISED CN and UPN :4361A-GTDMBN

30 – 1000 MHz

Intertek Japan K.K.
Nagano No.3 Test Site
 Spurious Emissions - Radiated Test

APPLICANT : AIPHONE Co., LTD
 EUT NAME : Entrance station (Integrated Type)
 MODEL NO. : GT-DMB-LVN
 SERIAL NO. : 0000169R(J725-2436)
 TEST MODE : Confirmation of NFC reader
 POWER SOURCE : AC120 V, 60 Hz
 DATE TESTED : Feb 22 2017
 FILE NO. : -
 REGULATION : FCC part15C (15.209)
 TEST METHOD : ANSI C63.10-2013
 DISTANCE : 3.00 [m]
 TEMPERATURE : 24.2 [degC]
 HUMIDITY : 16.0 [%]
 NOTE : X

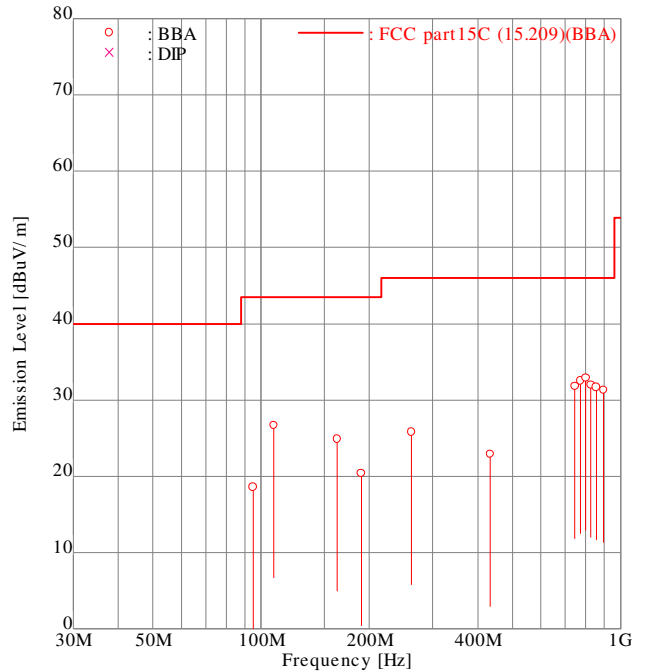

ENGINEER : Yoshihide Mimura

FREQ [No]	FREQ [MHz]	ANT.	READING [dBuV]		FACTOR [dB/m]		EMISSION [dBuV/m]		LIMIT [dBuV/m]		MARGIN [dB]	
			Hori	Vert	Hori	Vert	Hori	Vert	Hori	Vert		
1	94.92	BBA	-	32.0	-13.4	-13.4	-	18.6	43.5	-	24.9	
2	108.48	BBA	37.5	38.7	-12.0	-12.0	25.5	26.7	43.5	18.0	16.8	
3	162.72	BBA	-	38.0	-13.1	-13.1	-	24.9	43.5	-	18.6	
4	189.84	BBA	-	31.9	-11.5	-11.5	-	20.4	43.5	-	23.1	
5	261.37	BBA	33.2	-	-7.4	-7.4	25.8	-	46.0	20.2	-	
6	433.92	BBA	-	24.8	-1.9	-1.9	-	22.9	46.0	-	23.1	
7	745.80	BBA	<u>26.8</u>	-	5.0	5.0	<u>31.8</u>	-	46.0	<u>14.2</u>	-	
8	772.92	BBA	<u>26.8</u>	-	5.7	5.7	<u>32.5</u>	-	46.0	<u>13.5</u>	-	
9	800.04	BBA	<u>26.6</u>	-	6.3	6.3	<u>32.9</u>	-	46.0	<u>13.1</u>	-	
10	827.16	BBA	<u>25.3</u>	-	6.7	6.7	<u>32.0</u>	-	46.0	<u>14.0</u>	-	
11	854.28	BBA	<u>24.7</u>	-	7.0	7.0	<u>31.7</u>	-	46.0	<u>14.3</u>	-	
12	894.96	BBA	<u>23.6</u>	-	7.7	7.7	<u>31.3</u>	-	46.0	<u>14.7</u>	-	

Higher six points are underlined.
 Other frequencies : Below the FCC part15C (15.209) limit
 Emission Level = Read + Factor(Antenna, Antenna Pad, Cable, Preamp)
 ANT. : Used antenna(BBA = Broadband antenna, DIP = Dipole antenna)

FCC ID : 2ALNEGTDMBN
 ISED CN and UPN :4361A-GTDMBN

1000 – 2000 MHz

Intertek Japan K.K.
Nagano No.2 Test Site
 Radiated Electric Field

APPLICANT : AIPHONE Co., LTD
 EUT NAME : Entrance station (Integrated Type)
 MODEL NO. : GT-DMB-LVN
 SERIAL NO. : 0000169R(J725-2436)
 TEST MODE : Confirmation of NFC reader
 POWER SOURCE : AC120 V, 60 Hz
 DATE TESTED : Feb 16 2017
 FILE NO. : -
 REGULATION : FCC part15C (15.209)
 TEST METHOD : ANSI C63.10-2013
 DISTANCE : 3.88 [m]
 TEMPERATURE : 17.5 [degC]
 HUMIDITY : 24.0 [%]
 NOTE : X

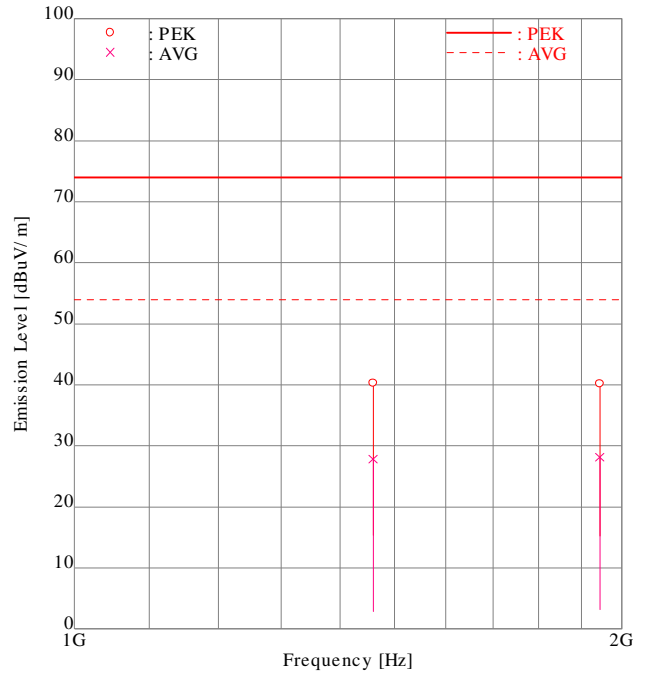

ENGINEER : Yoshihide Mimura

FREQUENCY [No]	MODE [MHz]		READING [dBuV]		FACTOR [dB]		EMISSION [dBuV/m]		LIMIT [dBuV/m]		MARGIN [dB]	
			Hori	Vert	Hori	Vert	Hori	Vert	Hori	Vert		
1	1460.06	PEK	<u>40.7</u>	40.3	-0.4	-0.4	<u>40.3</u>	39.9	74.0	<u>33.7</u>	34.1	
2	1460.06	AVG	28.1	<u>28.2</u>	-0.4	-0.4	27.7	<u>27.8</u>	54.0	26.3	<u>26.2</u>	
3	1945.38	PEK	-	<u>40.1</u>	0.1	0.1	-	<u>40.2</u>	74.0	-	<u>33.8</u>	
4	1945.38	AVG	-	<u>28.0</u>	0.1	0.1	-	<u>28.1</u>	54.0	-	<u>25.9</u>	

Higher six points are underlined.
 Other frequencies : Below the FCC part15C (15.209) limit
 Emission Level=Read+Fact.
 Fact.=Ant. Fact.+Cable Loss-Amp. Gain+ATT+Dist. Conversion

FCC ID : 2ALNEGTDMBN
 ISED CN and UPN :4361A-GTDMBN

9.1.2.5 Out band
0.009 – 30 MHz (Y axis)

Intertek Japan K.K.

Nagano No.3 Test Site

Spurious Emission - Radiated Test

APPLICANT : AIPHONE Co., LTD
 EUT NAME : Entrance station (Integrated Type)
 MODEL NO. : GT-DMB-LVN
 SERIAL NO. : 0000169R(J725-2436)
 TEST MODE : Confirmation of NFC reader
 POWER SOURCE : AC120 V, 60 Hz
 DATE TESTED : Feb 20 2017
 FILE NO. : -
 REGULATION : FCC part15C (15.209)
 TEST METHOD : ANSI C63.10-2013
 DISTANCE : 3.00 [m]
 TEMPERATURE : 18.0 [degC]
 HUMIDITY : 51.0 [%]
 NOTE : Y

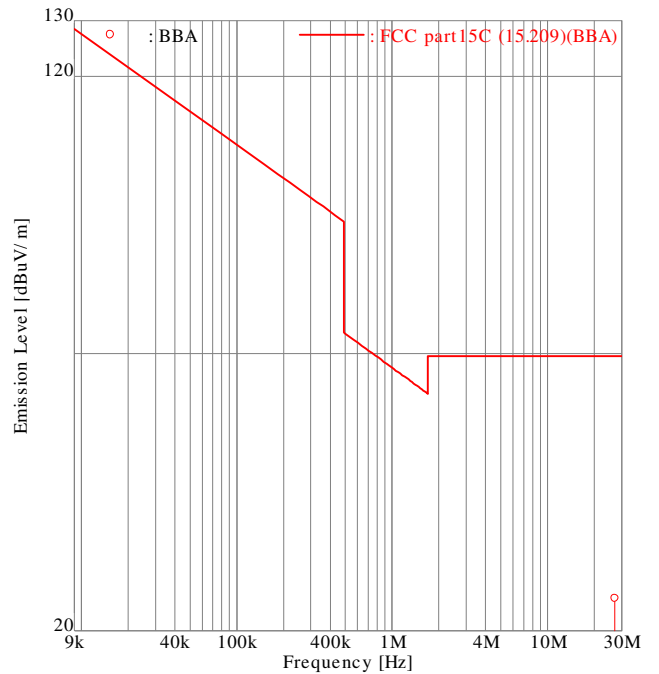

ENGINEER : Yoshihide Mimura

FREQUENCY [No]	FREQUENCY [MHz]	READING [dBuV]	FACTOR [dB]	EMISSION [dBuV/m]	LIMIT [dBuV/m]	MARGIN [dB]
1	27.1200	<u>24.3</u>	1.6	<u>25.9</u>	69.5	<u>43.6</u>

Higher six points are underlined.
 Other frequencies : Below the FCC part15C (15.209) limit
 Emission Level = Read + Factor(Antenna,Antenna Pad,Cable,Preamp)

FCC ID : 2ALNEGTDMBN
 ISED CN and UPN :4361A-GTDMBN

30 – 1000 MHz

Intertek Japan K.K.
Nagano No.3 Test Site
 Spurious Emissions - Radiated Test

APPLICANT : AIPHONE Co., LTD
 EUT NAME : Entrance station (Integrated Type)
 MODEL NO. : GT-DMB-LVN
 SERIAL NO. : 0000169R(J725-2436)
 TEST MODE : Confirmation of NFC reader
 POWER SOURCE : AC120 V, 60 Hz
 DATE TESTED : Feb 22 2017
 FILE NO. : -
 REGULATION : FCC part15C (15.209)
 TEST METHOD : ANSI C63.10-2013
 DISTANCE : 3.00 [m]
 TEMPERATURE : 24.2 [degC]
 HUMIDITY : 16.0 [%]
 NOTE : Y

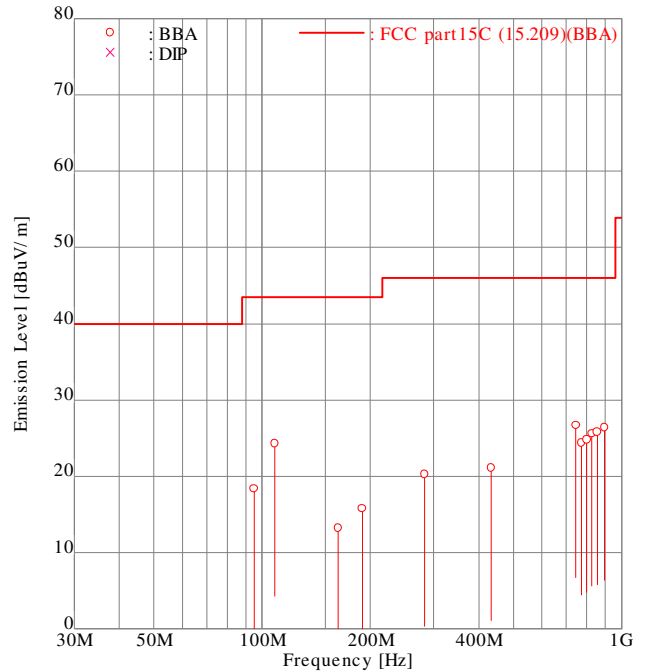

ENGINEER : Yoshihide Mimura

FREQ [No]	FREQ [MHz]	ANT.	READING [dBuV]		FACTOR [dB/m]		EMISSION [dBuV/m]		LIMIT [dBuV/m]		MARGIN [dB]	
			Hori	Vert	Hori	Vert	Hori	Vert	Hori	Vert		
1	94.92	BBA	-	31.8	-13.4	-13.4	-	18.4	43.5	-	25.1	
2	108.48	BBA	25.4	<u>36.3</u>	-12.0	-12.0	13.4	<u>24.3</u>	43.5	30.1	<u>19.2</u>	
3	162.72	BBA	-	26.3	-13.1	-13.1	-	13.2	43.5	-	30.3	
4	189.84	BBA	-	27.3	-11.5	-11.5	-	15.8	43.5	-	27.7	
5	283.24	BBA	26.9	-	-6.6	-6.6	20.3	-	46.0	25.7	-	
6	433.92	BBA	-	23.0	-1.9	-1.9	-	21.1	46.0	-	24.9	
7	745.80	BBA	<u>21.7</u>	21.5	5.0	5.0	<u>26.7</u>	26.5	46.0	<u>19.3</u>	19.5	
8	772.92	BBA	18.7	-	5.7	5.7	24.4	-	46.0	21.6	-	
9	800.04	BBA	<u>18.5</u>	-	6.3	6.3	<u>24.8</u>	-	46.0	<u>21.2</u>	-	
10	827.16	BBA	<u>18.9</u>	-	6.7	6.7	<u>25.6</u>	-	46.0	<u>20.4</u>	-	
11	854.28	BBA	<u>18.8</u>	-	7.0	7.0	<u>25.8</u>	-	46.0	<u>20.2</u>	-	
12	894.96	BBA	<u>18.7</u>	-	7.7	7.7	<u>26.4</u>	-	46.0	<u>19.6</u>	-	

Higher six points are underlined.
 Other frequencies : Below the FCC part15C (15.209) limit
 Emission Level = Read + Factor(Antenna, Antenna Pad, Cable, Preamp)
 ANT. : Used antenna(BBA = Broadband antenna, DIP = Dipole antenna)

FCC ID : 2ALNEGTDMBN
 ISED CN and UPN :4361A-GTDMBN

1000 – 2000 MHz

Intertek Japan K.K.
Nagano No.2 Test Site
 Radiated Electric Field

APPLICANT : AIPHONE Co., LTD
 EUT NAME : Entrance station (Integrated Type)
 MODEL NO. : GT-DMB-LVN
 SERIAL NO. : 0000169R(J725-2436)
 TEST MODE : Confirmation of NFC reader
 POWER SOURCE : AC120 V, 60 Hz
 DATE TESTED : Feb 16 2017
 FILE NO. : -
 REGULATION : FCC part15C (15.209)
 TEST METHOD : ANSI C63.10-2013
 DISTANCE : 3.88 [m]
 TEMPERATURE : 17.5 [degC]
 HUMIDITY : 24.0 [%]
 NOTE : Y

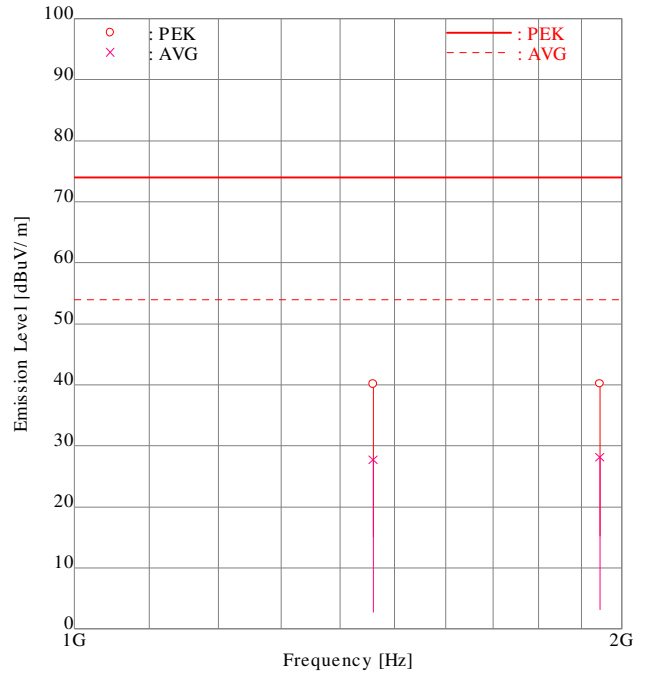

ENGINEER : Yoshihide Mimura

FREQUENCY [No]	MODE [MHz]		READING [dBuV]		FACTOR [dB]		EMISSION [dBuV/m]		LIMIT [dBuV/m]		MARGIN [dB]	
			Hori	Vert	Hori	Vert	Hori	Vert	Hori	Vert		
1	1460.02	PEK	<u>40.5</u>	40.3	-0.4	-0.4	<u>40.1</u>	39.9	74.0	<u>33.9</u>	34.1	
2	1460.02	AVG	28.0	<u>28.1</u>	-0.4	-0.4	27.6	<u>27.7</u>	54.0	26.4	<u>26.3</u>	
3	1945.37	PEK	-	<u>40.1</u>	0.1	0.1	-	<u>40.2</u>	74.0	-	<u>33.8</u>	
4	1945.37	AVG	-	<u>28.0</u>	0.1	0.1	-	<u>28.1</u>	54.0	-	<u>25.9</u>	

Higher six points are underlined.
 Other frequencies : Below the FCC part15C (15.209) limit
 Emission Level=Read+Fact.
 Fact.=Ant. Fact.+Cable Loss-Amp. Gain+ATT+Dist. Conversion

FCC ID : 2ALNEGTDMBN
 ISED CN and UPN :4361A-GTDMBN

9.1.2.6 Out band
0.009 – 30 MHz (Z axis)

Intertek Japan K.K.

Nagano No.3 Test Site

Spurious Emission - Radiated Test

APPLICANT : AIPHONE Co., LTD
 EUT NAME : Entrance station (Integrated Type)
 MODEL NO. : GT-DMB-LVN
 SERIAL NO. : 0000169R(J725-2436)
 TEST MODE : Confirmation of NFC reader
 POWER SOURCE : AC120 V, 60 Hz
 DATE TESTED : Feb 20 2017
 FILE NO. : -
 REGULATION : FCC part15C (15.209)
 TEST METHOD : ANSI C63.10-2013
 DISTANCE : 3.00 [m]
 TEMPERATURE : 18.0 [degC]
 HUMIDITY : 51.0 [%]
 NOTE : Z

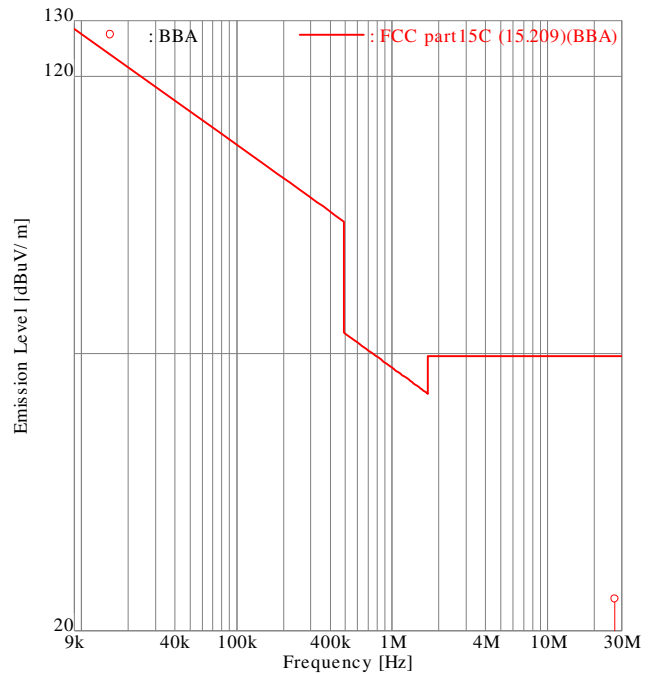

ENGINEER : Yoshihide Mimura

FREQUENCY [No]	FREQUENCY [MHz]	READING [dBuV]	FACTOR [dB]	EMISSION [dBuV/m]	LIMIT [dBuV/m]	MARGIN [dB]
1	27.1200	<u>24.2</u>	1.6	<u>25.8</u>	69.5	<u>43.7</u>

Higher six points are underlined.
 Other frequencies : Below the FCC part15C (15.209) limit
 Emission Level = Read + Factor(Antenna,Antenna Pad,Cable,Preamp)

FCC ID : 2ALNEGTDMBN
 ISED CN and UPN :4361A-GTDMBN

30 – 1000 MHz

Intertek Japan K.K.
Nagano No.3 Test Site
 Spurious Emissions - Radiated Test

APPLICANT : AIPHONE Co., LTD
 EUT NAME : Entrance station (Integrated Type)
 MODEL NO. : GT-DMB-LVN
 SERIAL NO. : 0000169R(J725-2436)
 TEST MODE : Confirmation of NFC reader
 POWER SOURCE : AC120 V, 60 Hz
 DATE TESTED : Feb 22 2017
 FILE NO. : -
 REGULATION : FCC part15C (15.209)
 TEST METHOD : ANSI C63.10-2013
 DISTANCE : 3.00 [m]
 TEMPERATURE : 24.2 [degC]
 HUMIDITY : 16.0 [%]
 NOTE : Z

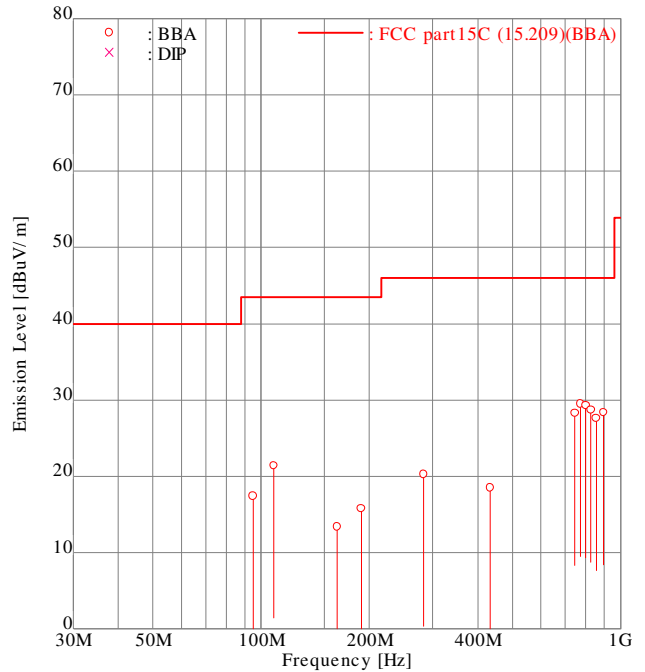

ENGINEER : Yoshihide Mimura

FREQUENCY [No]	ANT. [MHz]	READING [dBuV]		FACTOR [dB/m]		EMISSION [dBuV/m]		LIMIT [dBuV/m]	MARGIN [dB]		
		Hori	Vert	Hori	Vert	Hori	Vert		Hori	Vert	
1	94.92	BBA	-	30.8	-13.4	-13.4	-	17.4	43.5	-	26.1
2	108.48	BBA	27.8	33.4	-12.0	-12.0	15.8	21.4	43.5	27.7	22.1
3	162.72	BBA	-	26.5	-13.1	-13.1	-	13.4	43.5	-	30.1
4	189.84	BBA	-	27.3	-11.5	-11.5	-	15.8	43.5	-	27.7
5	283.24	BBA	26.9	-	-6.6	-6.6	20.3	-	46.0	25.7	-
6	433.92	BBA	-	20.4	-1.9	-1.9	-	18.5	46.0	-	27.5
7	745.80	BBA	21.7	<u>23.3</u>	5.0	5.0	26.7	<u>28.3</u>	46.0	19.3	<u>17.7</u>
8	772.92	BBA	<u>23.8</u>	-	5.7	5.7	<u>29.5</u>	-	46.0	<u>16.5</u>	-
9	800.04	BBA	<u>23.0</u>	-	6.3	6.3	<u>29.3</u>	-	46.0	<u>16.7</u>	-
10	827.16	BBA	<u>22.0</u>	-	6.7	6.7	<u>28.7</u>	-	46.0	<u>17.3</u>	-
11	854.28	BBA	<u>20.6</u>	-	7.0	7.0	<u>27.6</u>	-	46.0	<u>18.4</u>	-
12	894.96	BBA	<u>20.7</u>	-	7.7	7.7	<u>28.4</u>	-	46.0	<u>17.6</u>	-

Higher six points are underlined.
 Other frequencies : Below the FCC part15C (15.209) limit
 Emission Level = Read + Factor(Antenna, Antenna Pad, Cable, Preamp)
 ANT. : Used antenna(BBA = Broadband antenna, DIP = Dipole antenna)

FCC ID : 2ALNEGTDMBN
 ISED CN and UPN :4361A-GTDMBN

1000 – 2000 MHz

Intertek Japan K.K.
Nagano No.2 Test Site
 Radiated Electric Field

APPLICANT : AIPHONE Co., LTD
 EUT NAME : Entrance station (Integrated Type)
 MODEL NO. : GT-DMB-LVN
 SERIAL NO. : 0000169R(J725-2436)
 TEST MODE : Confirmation of NFC reader
 POWER SOURCE : AC120 V, 60 Hz
 DATE TESTED : Feb 16 2017
 FILE NO. : -
 REGULATION : FCC part15C (15.209)
 TEST METHOD : ANSI C63.10-2013
 DISTANCE : 3.82 [m]
 TEMPERATURE : 17.5 [degC]
 HUMIDITY : 24.0 [%]
 NOTE : Z

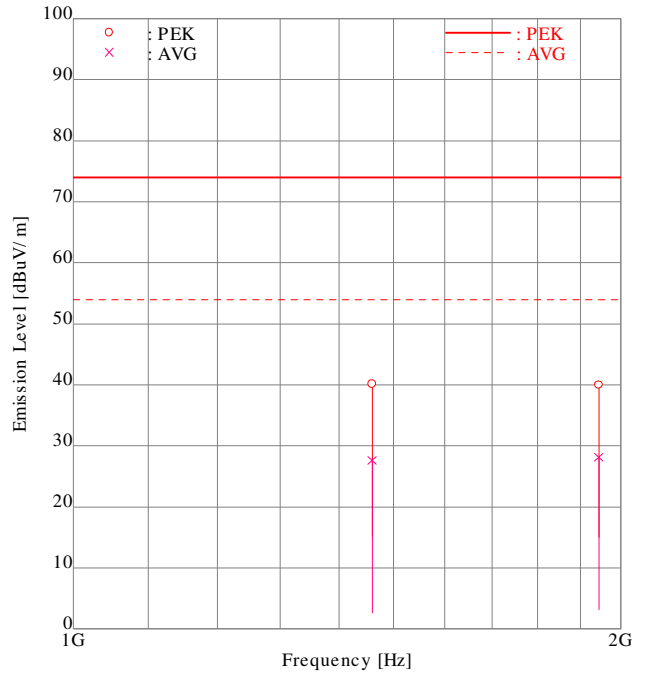

ENGINEER : Yoshihide Mimura

FREQUENCY [No]	MODE [MHz]		READING [dBuV]		FACTOR [dB]		EMISSION [dBuV/m]		LIMIT [dBuV/m]		MARGIN [dB]	
			Hori	Vert	Hori	Vert	Hori	Vert	Hori	Vert	Hori	Vert
1	1460.06	PEK	<u>40.6</u>	40.4	-0.5	-0.5	<u>40.1</u>	39.9	74.0	<u>33.9</u>	34.1	
2	1460.06	AVG	<u>28.1</u>	28.0	-0.5	-0.5	<u>27.6</u>	27.5	54.0	<u>26.4</u>	26.5	
3	1945.33	PEK	-	<u>40.0</u>	-0.0	-0.0	-	<u>40.0</u>	74.0	-	<u>34.0</u>	
4	1945.33	AVG	-	<u>28.1</u>	-0.0	-0.0	-	<u>28.1</u>	54.0	-	<u>25.9</u>	

Higher six points are underlined.
 Other frequencies : Below the FCC part15C (15.209) limit
 Emission Level=Read+Fact.
 Fact.=Ant. Fact.+Cable Loss-Amp. Gain+ATT+Dist. Conversion

9.2 Frequency Tolerance (Temperature Variation and Voltage Variation)

Location	Kashima No.1
Test date	March 9, 2017
Test Engineer	Yoshihide Mimura
Test Procedure	LEN-RJP-TE003

Test Procedure

Frequency Tolerance (Temperature Variation)

1. The EUT and test equipment were set up as shown on the following page.
2. Set the temperature -30 degrees C.
3. Leave the EUT for 1 hour after it became the temperature that was set up.
4. Make the EUT the transmitting.
5. Measure the output frequency. (Startup, 2min, 5min and 10min)
6. Set the temperature -20 degrees C to +50 degrees C.
7. Repeat test procedure 4 to 6

Frequency Tolerance (Voltage Variation)

1. The EUT and test equipment (Set the Supply Voltage 100%) were set up as shown on the following page.
2. Set the temperature +20 degrees C.
3. Leave the EUT for 1 hour after it became the temperature that was set up.
4. Make the EUT the transmitting.
5. Measure the output frequency.
6. Set the Supply Voltage 85% and 115%.
7. Repeat test procedure 4 to 6

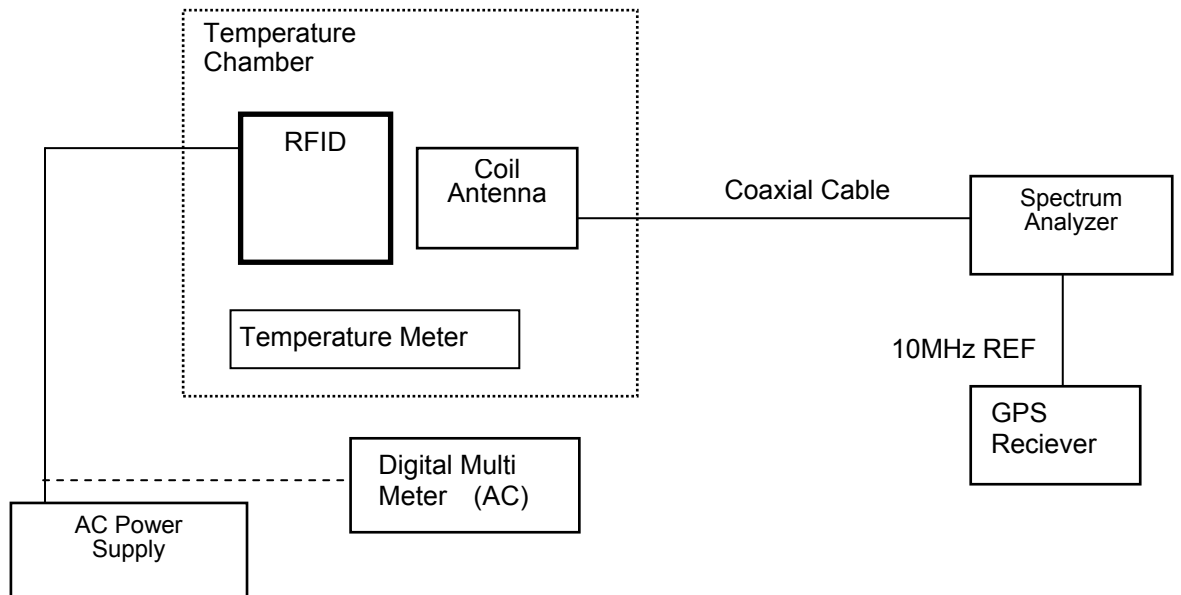

FCC ID : 2ALNEGTDMBN
ISED CN and UPN :4361A-GTDMBN**Result of Frequency Tolerance (Temperature Variation and Voltage Variation)****9.2.1 Temperature Variation**

Reference Frequency: 13.560000 MHz (FCC Stability) /13.560120 MHz (RSS Stability)

MHz	Temperature (Degree C)	Voltage (%)	Frequency (MHz)	Deviation (ppm)		Limit (+/-) (ppm)
				FCC	RSS	
13.56	-30	100	13.560115	8.48	-0.37	100.0
	-20	100	13.560116	8.55	-0.29	100.0
	-10	100	13.560120	8.85	0.00	100.0
	0	100	13.560120	8.85	0.00	100.0
	10	100	13.560121	8.92	0.07	100.0
	20	100	13.560120	8.85	0.00	100.0
	30	100	13.560112	8.26	-0.59	100.0
	40	100	13.560110	8.11	-0.74	100.0
	50	100	13.560113	8.33	-0.52	100.0

9.2.2 Voltage Variation

Reference Frequency: 13.560000 MHz (FCC Stability) /13.560120 MHz (RSS Stability)

MHz	Temperature (Degree C)	Voltage (%)	Frequency (MHz)	Deviation (ppm)		Supply Voltage		Limit (+/-) (ppm)
				FCC	RSS			
13.56	20	85	13.560120	8.85	0.00	102V	60Hz	100.0
		100	13.560120	8.85	0.00	120V	60Hz	100.0
		115	13.560120	8.85	0.00	138V	60Hz	100.0

FCC ID : 2ALNEGTDMBN
 ISED CN and UPN :4361A-GTDMBN

9.3 20dB OBW , 99% OBW

Location	Nagano No.3 Test Site
Test date	March 17, 2016
Test Engineer	Yoshihide Mimura
Test Procedure	LEN-RJP-TE003

Test Procedure

- 1 The EUT and test equipment were set up as shown on the following page.
- 2 Adjust the test instrument for the following setting:
 RBW : 1 % to 5 % of the Necessary bandwidth
 VBW : at least 3 times the RBW
 Detector : Peak
 Sweep Time : Auto
 Trace mode : Max Hold
- 3 Allow trace to fully stabilize.
- 4 Use "Occupied Bandwidth Measurement" function to measure the Occupied Bandwidth.

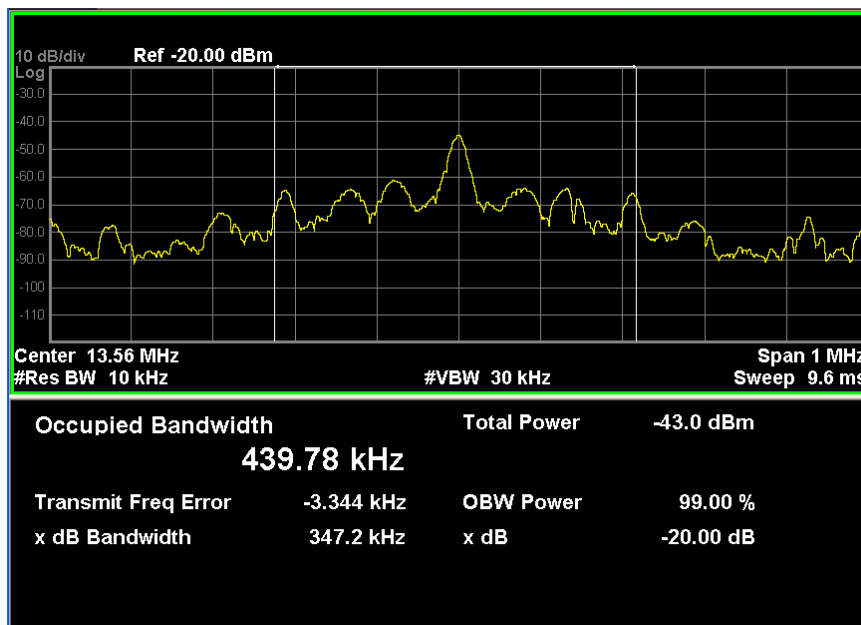

FCC ID : 2ALNEGTDMBN
ISED CN and UPN :4361A-GTDMBN**SECTION 10. LIST OF MEASURING INSTRUMENTS**

Test instruments are calibrated according to Quality Manual and Calibration Rules of Intertek Japan K.K.

All measurements equipment used for the measurement is calibrated based on standard.

Each measurement result is traceable to national or international standards.

Antenna used for the measurement is calibrated based on the ANSI C63.5.

Instrument	Model No.	Serial No.	Manufacturer	Cal. Interval	Effective period
Conducted disturbance at mains terminals					
LISN (EUT)	ESH2-Z5	892377/022	ROHDE & SCHWARZ	1 Y	May 31, 17
10 dB Attenuator	CFA-01	CEC052	TAMAGAWA		
Coaxial cable	5D-2W(5.5 m)	N3C-1	Intertek	1 Y	Jan. 31, 18
Coaxial cable	5D-2W(1.6 m)	N3C-2	Intertek		
Coaxial cable	5D-2W(0.7 m)	N3C-3	Intertek		
Coaxial cable	5D-2W(1.6 m)	N3C-4	Intertek		
RF Switch	ACX-150-1	CE3010	Intertek		
Test receiver	ESS (Firmware Version 1.21)	842886/011	ROHDE & SCHWARZ	1 Y	Feb. 28, 18
Radiated disturbance (30 MHz-1000 MHz)					
Loop Antenna	HFH2-Z2	892665/009	ROHDE & SCHWARZ	1 Y	Oct. 31, 18
Coaxial cable	3D-2V(15m)	CL1	Intertek	1 Y	Sep. 30, 17
Broad Band antenna	LPB-2513/A	1092	A.R.A.	1 Y	Jun. 30, 17
6 dB Attenuator	8491A	36306	HEWLETT PACKARD	1 Y	Jan. 31, 18
Step Attenuator	8494B	2812A15596	HEWLETT PACKARD		
Amplifier	8447D	2727A05731	HEWLETT PACKARD		
Coaxial cable	5D-SFA(9.8 m)	N3R-1	Intertek		
Coaxial cable	12D-SFA(8.0 m)	N3R-2	Intertek		
Coaxial cable	5D-2W(1.6 m)	N3R-3	Intertek		
Coaxial cable	5D-2W(0.4 m)	N3R-4	Intertek		
Coaxial cable	5D-2W(0.4 m)	N3R-5	Intertek		
Coaxial cable	5D-2W(0.7 m)	N3R-6	Intertek		
Coaxial cable	5D-2W(1.6 m)	N3R-7	Intertek		
RF Switch	ACX-150-1	CE3010	Intertek		
Test receiver	ESS (Firmware Version 1.21)	842886/011	ROHDE & SCHWARZ	1 Y	Feb. 28, 18
Site Attenuation	-	-	-	1 Y	Apr. 30, 17

FCC ID : 2ALNEGTDMBN
ISED CN and UPN :4361A-GTDMBN

Instrument	Model No.	Serial No.	Manufacturer	Cal. Interval	Effective period
Radiated disturbance (Above 1 GHz)					
Double Ridged antenna	BBHA9120D	278	Schwarzbeck	1 Y	May, 2017
6 dB Attenuator	SFA-01A 6 dB	CEC039	TAMAGAWA	1 Y	Jun, 2017
Amplifier (1-18 GHz)	EAU-3018GXA	10315	ELENA	1 Y	Jun, 2017
Coaxial cable	SUCOFLEX 100 (0.2 m)	G2 (1513/2EA) CEC023	SUHNER	1 Y	Jun, 2017
Coaxial cable	S04272B (8.0m)	G5 (11SMA/8m)	SUHNER	1 Y	Aug, 2017
EMC Analyzer	E7403A (Firmware Rev.: A.11.00)	MY42000068	Agilent	1 Y	Jun, 2017
SVSWR	-	-	-	1 Y	Aug, 2017
Frequency Tolerance and OBW					
Spectrum Analyzer	N9030A	US51350220	Agilent	1 Y	Feb. 28, 18
Spectrum Analyzer	E7401	US39440254	Agilent	1 Y	Nov. 30, 17
Digital Multi Meter	34401A	US36043517	Hewlett Packard	1 Y	Jan. 31, 18
Temperature Chamber	PL-3F	5103661	Tabai	-	None
Temperature Meter	PC-5000TRH-II	A11999972	Sato	1 Y	Feb. 28, 18
Coil antenna	None	None	Intertek Japan	-	None
GPS Receiver	HP Z3801A	3542A02414	Hewlett Packard	-	None
Coaxial Cable	3D-2V	KSR00100	Daiyu Densen	1 Y	Jan. 31, 18

ANNEX

A. TEST PROCEDURE(S)

Test was carried out under the following conditions.

Conducted disturbance at mains terminals

Test setup as per standard

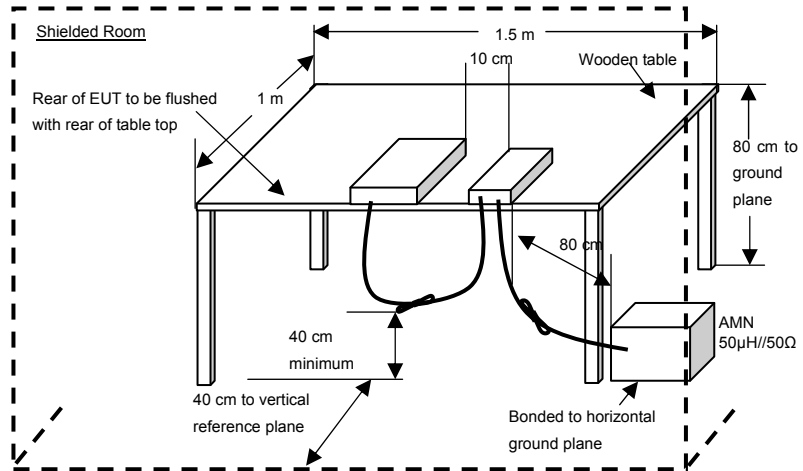

* Reference Ground plane : greater than 2 x 2m

Diagram of the measuring instruments

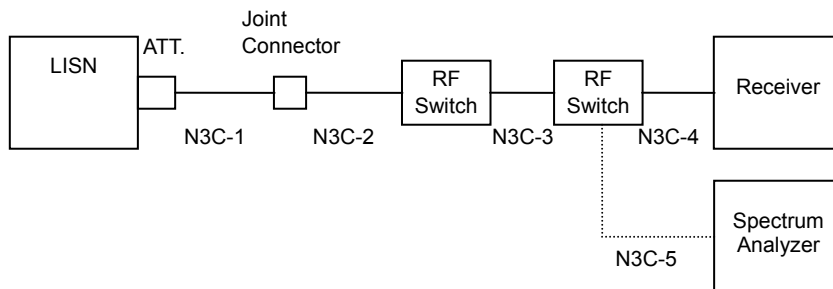

Setting for the instruments

Frequency [MHz]	Instrument	Detector Function	Resolution Bandwidth	Video Bandwidth
0.15 – 30	Receiver	Quasi Peak	10 kHz	N/A
		Average	10 kHz	N/A

[Preliminary Measurement]

EUT is tested on all operating conditions.

The spectrum analyzer is controlled by the computer program to sweep the frequency range to be measured, then spectrum chart is plotted out to find the worst emission conditions in operating mode and/or configuration decision for the final test.

All leads other than safety ground are tested.

[Final Measurement]

The EUT is operated in the worst emission condition found by the preliminary test.

The equipment and cables are arranged or manipulated within the range of the test standard in the above condition.

At least six highest spectrum are measured in quasi-peak and average (if necessary) using the test receiver.

Radiated disturbance
Test setup as per standard

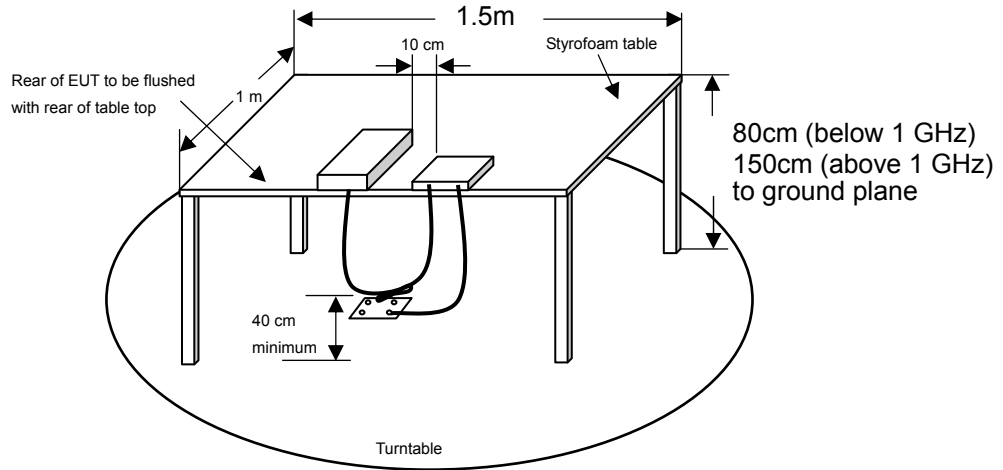
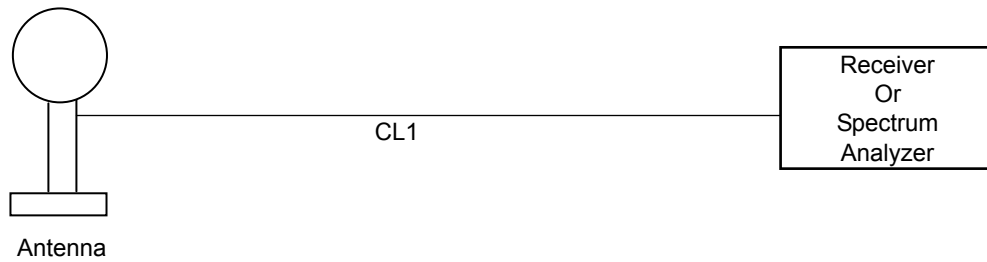
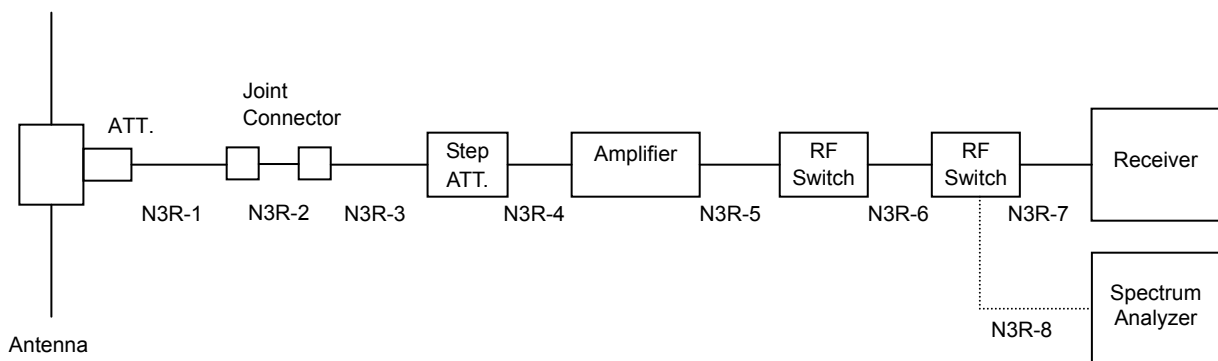

Diagram of the measuring instruments

0.009 – 30MHz



30 – 1000 MHz



Above 1GHz

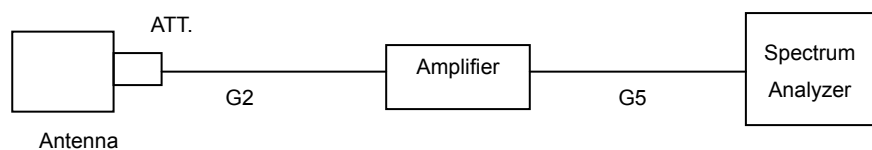

Test was carried out under the following conditions.