

深圳鸿日晟威科技有限公司
Shenzhen Hongri Shengwei Technology Co., LTD

产品规格承认书

SPECIFICATON APPROVAL

客户名称:

CUSTOMER: TRANSTYLE TECHNOLOGY CO., LIMITED

客户品名:

Product Name ofCustomer: Wireless charging
transmitter coil

我方产品名 (材质):

product Mame

ofOurs(Maternal):D43.5MM-10TS-6.5UH

Manufacturer: Shenzhen Hongri Shengwei Technology
Co., LTD

Address: 201, 48 Huanguan Middle Road, Guancheng
Community, Guanhu Street, Longhua District, Shenzhen

Specification 规格内容		CUSTOMER/N: 客户品名	Wireless charging transmitter coil
		PARTNUMBER: 制造商料号	D43.5MM-10TS-6.5UH

1.DIMENSIONS(外形尺寸): Unit (mm)

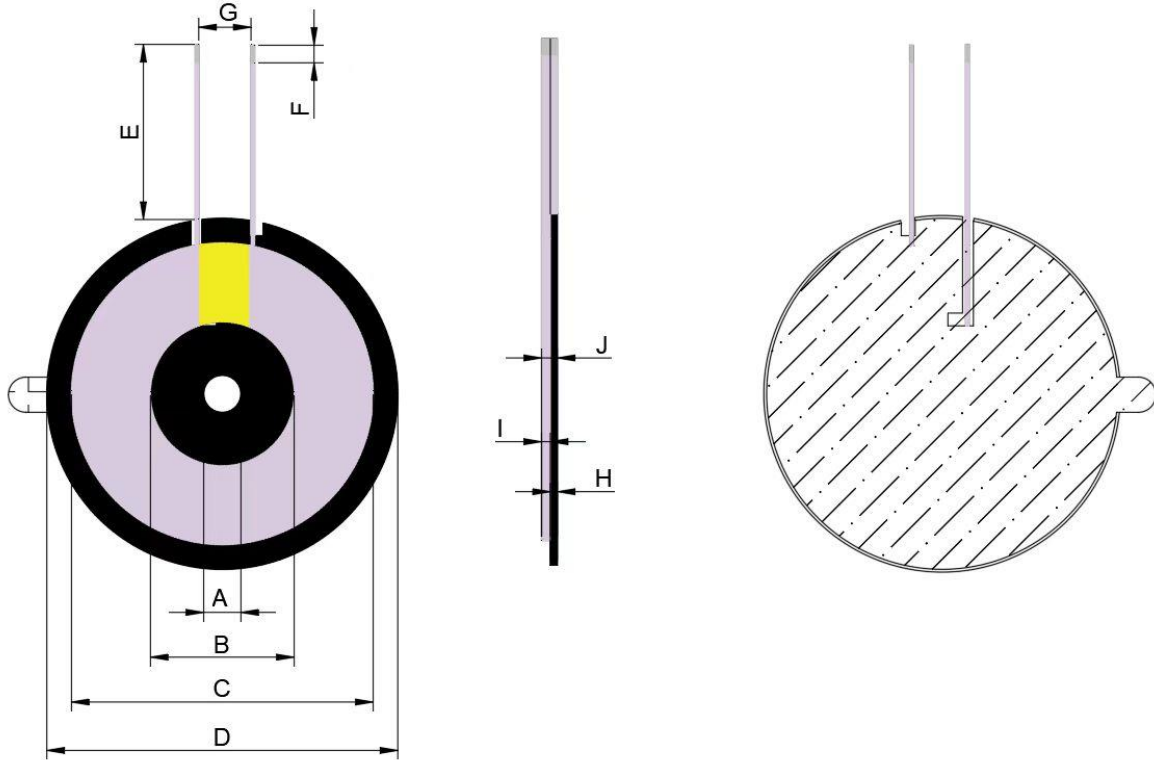

	A	B	C	D	E	F	G				
尺寸(Dim)	5	20.5	38.5	43.5	35	2	1.6				
公差(Tol.)	±0.2	±0.5	±0.5	±0.5	±2	±1	±0.2				

Specifcation 规格内容	CUSTOMERP/N: 客户名称	Wireless charging transmitter coil
	PARTNUMBER: 制造商料号	D43.5MM-10TS-6.5UH

5.WINDING DETAILS(绕线详细说明):

Wdy.NO. 绕组	Start 开始	Finish 结束	Turns 圈数	Wire Dia 线径	Wdg.TyepSprad/lose 绕线方法疏/密绕	Wdg.Direction 绕线方向	Layer 层数
	S	F	20TS	0.08*24P	Dense winding	Counterclockwise	1 Layer

6.ELECTRICAL CHARACTERISTICS(电气特性):

PARAMETERS	UNIN	LIMTI
Inductance $I_s@100KHz/1v$	UH	$6.5UH \pm 10\%$
Q @100KHz/1v	Q	$43 \pm 10\%$
DCR	Ω	$0.085 \pm 10\%$

MATERIAL LIST 材料清单		CUSTOMER P/N: 客户品名		Wireless charging transmitter coil
		PARTNUMBER: 制造商料号		D43.5MM-10TS-6.8UH
NO.	Material name 材料名称	Description 品名描述	Manufacturer 制造商	UL NO. 编号
1	Hot air line	0.08mm*24P		
2	Lead-free tin bars	high temperature		
3	Ferrite hard magnetic sheets	43.5MM*5MM*0.8M M		
4	Pearl cotton	38CM*27CM*5.5CM		
5	carton	45CM*29CM*35CM		
6				
7				
8				
9				
10				