

FCC

RF

TEST REPORT

ISSUED BY  
Shenzhen BALUN Technology Co., Ltd.



FOR  
**Motion Controller**

ISSUED TO  
Guangdong Virtual Reality Technology Co., Ltd

Shenzhen Flour Limited, South Gate 3rd Floor, 9106 Beihuan Avenue,  
Nanshan District, Shenzhen, Guangdong

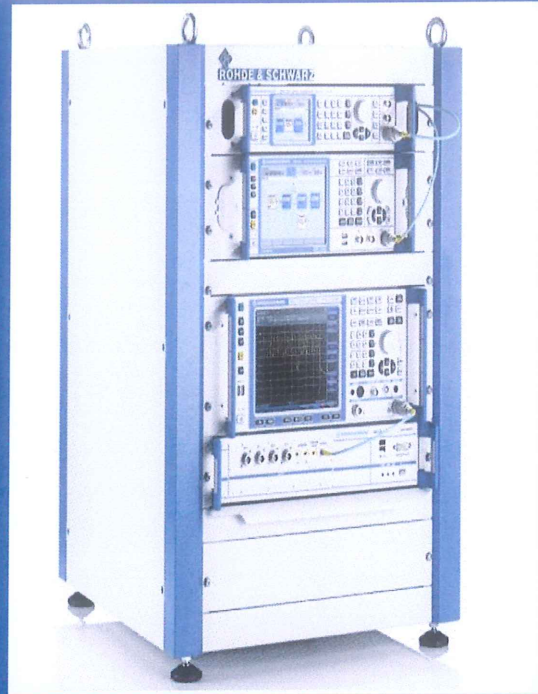

Tested by:

*Zheng Muyi*

Zheng Muyi  
(Engineer)

Date

*Jul. 14, 2017*

Approved by:

*Tu Lang*

Tu Lang

(Engineer Manager)

Date

*Jul. 14, 2017*

Report No.: BL-SZ1750414-601

EUT Name: Motion Controller

Model Name: XCV01-CB, IH D100

Brand Name: Ximmerse

Test Standard: 47 CFR Part 15 Subpart C

FCC ID: 2ALLR-XCV01-CB

Test conclusion: Pass

Test Date: Jun. 01, 2017 ~ Jun. 13, 2017

Date of Issue: Jul. 14, 2017

*NOTE: This test report of test results only related to testing samples, which can be duplicated completely for the legal use with the approval of the applicant; it shall not be reproduced except in full, without the written approval of Shenzhen BALUN Technology Co., Ltd. BALUN Laboratory. Any objections should be raised within thirty days from the date of issue. To validate the report, please contact us.*

**Revision History**

<u>Version</u>	<u>Issue Date</u>	<u>Revisions</u>
<u>Rev. 01</u>	<u>Jun. 30, 2017</u>	<u>Initial Issue</u>
<u>Rev. 02</u>	<u>Jul. 14, 2017</u>	<u>Increase the brand name, Update setup photo and power limit</u>

**TABLE OF CONTENTS**

- 1 ADMINISTRATIVE DATA (GENERAL INFORMATION) ..... 5
  - 1.1 Identification of the Testing Laboratory ..... 5
  - 1.2 Identification of the Responsible Testing Location ..... 5
  - 1.3 Laboratory Condition ..... 5
  - 1.4 Announce ..... 5
- 2 PRODUCT INFORMATION ..... 6
  - 2.1 Applicant Information ..... 6
  - 2.2 Manufacturer Information ..... 6
  - 2.3 Factory Information ..... 6
  - 2.4 General Description for Equipment under Test (EUT) ..... 6
  - 2.5 Ancillary Equipment ..... 6
  - 2.6 Technical Information ..... 7
- 3 SUMMARY OF TEST RESULTS ..... 9
  - 3.1 Test Standards ..... 9
  - 3.2 Verdict ..... 9
- 4 GENERAL TEST CONFIGURATIONS ..... 10
  - 4.1 Test Environments ..... 10
  - 4.2 Test Equipment List ..... 10
  - 4.3 Description of Test Setup ..... 11
    - 4.3.1 For Antenna Port Test ..... 11
    - 4.3.2 For AC Power Supply Port Test ..... 11
    - 4.3.3 For Radiated Test (Below 30 MHz) ..... 12
    - 4.3.4 For Radiated Test (30 MHz-1 GHz) ..... 12
    - 4.3.5 For Radiated Test (Above 1 GHz) ..... 13
  - 4.4 Measurement Results Explanation Example ..... 13
    - 4.4.1 For conducted test items: ..... 13

4.4.2	For radiated band edges and spurious emission test:.....	13
5	TEST ITEMS .....	14
5.1	Antenna Requirements .....	14
5.1.1	Standard Applicable .....	14
5.1.2	Antenna Anti-Replacement Construction .....	14
5.1.3	Antenna Gain .....	14
5.2	Number of Hopping Frequency .....	15
5.2.1	Limit.....	15
5.2.2	Test Setup .....	15
5.2.3	Test Procedure .....	15
5.2.4	Test Result .....	15
5.3	Peak Output Power .....	16
5.3.1	Test Limit.....	16
5.3.2	Test Setup .....	16
5.3.3	Test Procedure .....	16
5.3.4	Test Result .....	16
5.4	Occupied Bandwidth.....	17
5.4.1	Limit.....	17
5.4.2	Test Setup .....	17
5.4.3	Test Procedure .....	17
5.4.4	Test Result .....	17
5.5	Carrier Frequency Separation.....	18
5.5.1	Limit.....	18
5.5.2	Test Setup .....	18
5.5.3	Test Procedure .....	18
5.5.4	Test Result .....	18
5.6	Time of Occupancy (Dwell time) .....	19
5.6.1	Limit.....	19
5.6.2	Test Setup .....	19
5.6.3	Test Procedure .....	19
5.6.4	Test Result .....	19
5.7	Conducted Spurious Emission & Authorized-band band-edge.....	20

5.7.1	Limit.....	20
5.7.2	Test Setup.....	20
5.7.3	Test Procedure.....	20
5.7.4	Test Result.....	20
5.8	Conducted Emission.....	21
5.8.1	Limit.....	21
5.8.2	Test Setup.....	21
5.8.3	Test Procedure.....	21
5.8.4	Test Result.....	21
5.9	Radiated Spurious Emission.....	22
5.9.1	Limit.....	22
5.9.2	Test Setup.....	22
5.9.3	Test Procedure.....	22
5.9.4	Test Result.....	23
5.10	Band Edge (Restricted-band band-edge).....	24
5.10.1	Limit.....	24
5.10.2	Test Setup.....	24
5.10.3	Test Procedure.....	24
5.10.4	Test Result.....	24
ANNEX A	TEST RESULT.....	25
A.1	Number of Hopping Frequency.....	25
A.2	Peak Output Power.....	26
A.3	20 dB and 99% bandwidth.....	27
A.4	Hopping Frequency Separation.....	29
A.5	Average Time of Occupancy.....	30
A.6	Conducted Spurious Emissions & Authorized-band band-edge.....	31
A.7	Conducted Emissions.....	34
A.8	Radiated Emission.....	35
A.9	Band Edge (Restricted-band band-edge).....	40
ANNEX B	TEST SETUP PHOTOS.....	42
ANNEX C	EUT EXTERNAL PHOTOS.....	42
ANNEX D	EUT INTERNAL PHOTOS.....	42

# 1 ADMINISTRATIVE DATA (GENERAL INFORMATION)

## 1.1 Identification of the Testing Laboratory

Company Name	Shenzhen BALUN Technology Co., Ltd.
Address	Block B, 1st FL, Baisha Science and Technology Park, Shahe Xi Road, Nanshan District, Shenzhen, Guangdong Province, P. R. China
Phone Number	+86 755 6685 0100

## 1.2 Identification of the Responsible Testing Location

Test Location	Shenzhen BALUN Technology Co., Ltd.
Address	Block B, 1st FL, Baisha Science and Technology Park, Shahe Xi Road, Nanshan District, Shenzhen, Guangdong Province, P. R. China
Accreditation Certificate	<p>The laboratory has been listed by Industry Canada to perform electromagnetic emission measurements. The recognition numbers of test site are 11524A-1.</p> <p>The laboratory has been listed by US Federal Communications Commission to perform electromagnetic emission measurements. The recognition numbers of test site are 832625.</p> <p>The laboratory is a testing organization accredited by China National Accreditation Service for Conformity Assessment (CNAS) according to ISO/IEC 17025. The accreditation certificate number is L6791.</p>
Description	All measurement facilities used to collect the measurement data are located at Block B, FL 1, Baisha Science and Technology Park, Shahe Xi Road, Nanshan District, Shenzhen, Guangdong Province, P. R. China 518055

## 1.3 Laboratory Condition

Ambient Temperature	20 to 25°C
Ambient Relative Humidity	45% - 55%
Ambient Pressure	100 kPa - 102 kPa

## 1.4 Announce

- (1) The test report reference to the report template version v2.1.
- (2) The test report is invalid if not marked with the signatures of the persons responsible for preparing and approving the test report.
- (3) The test report is invalid if there is any evidence and/or falsification.
- (4) The results documented in this report apply only to the tested sample, under the conditions and modes of operation as described herein.
- (5) This document may not be altered or revised in any way unless done so by BALUN and all revisions are duly noted in the revisions section.
- (6) Content of the test report, in part or in full, cannot be used for publicity and/or promotional purposes without prior written approval from the laboratory.

## 2 PRODUCT INFORMATION

### 2.1 Applicant Information

Applicant	Guangdong Virtual Reality Technology Co.,Ltd
Address	Shenzhen Flour Limited, South Gate 3rd Floor,9106 Beihuan Avenue, Nanshan District, Shenzhen, Guangdong

### 2.2 Manufacturer Information

Manufacturer	Guangdong Virtual Reality Technology Co.,Ltd
Address	Shenzhen Flour Limited, South Gate 3rd Floor,9106 Beihuan Avenue, Nanshan District, Shenzhen, Guangdong

### 2.3 Factory Information

Factory	Shenzhen Kaifa Technology Co.,Ltd
Address	Caitian Road 7006, Futian district, Shenzhen

### 2.4 General Description for Equipment under Test (EUT)

EUT Name	Motion Controller
Model Name Under Test	XCV01-CB
Series Model Name	XCV01-CB, IH D100
Description of Model name differentiation	All models are same with electrical parameters and internal circuit structure, but only differ in model name and outer decoration.
Hardware Version	B
Software Version	V2.0
Dimensions (Approx.)	N/A
Weight (Approx.)	N/A
Network and Wireless connectivity	2.4G ISM Band( GFSK modulation)

### 2.5 Ancillary Equipment

N/A

## 2.6 Technical Information

The requirement for the following technical information of the EUT was tested in this report:

Modulation Technology	FHSS
Modulation Type	GFSK
Product Type	<input checked="" type="checkbox"/> Mobile
Transfer Rate	2 Mbps
Frequency Range	The frequency range used is 2402 MHz – 2480 MHz; The frequency block is 2400 MHz to 2483.5 MHz.
Number of channel	15
Tested Channel	Low channel (2402 MHz), Middle channel(2451 MHz), High channel (2480 MHz)
Antenna Type	PCB Antenna
Antenna Gain	2 dBi (All involve the antenna gain test item, has been included in the final results)
Adaptive or non-adaptive	non-adaptive
The Max RF Output power	4.29 dBm

### Channel List

Number	Frequency (MHz)	Number	Frequency (MHz)
1	2402(Low)	9	2453
2	2404	10	2463
3	2423	11	2471
4	2425	12	2473
5	2427	13	2475
6	2442	14	2477
7	2449	15	2480(High)
8	2451(Middle)		

Test Case	Test Conditions			
	Modulation Technology	Modulation Type	Date rate	channel
Number of Hopping Frequency	FHSS	GFSK	2 Mbps	Hopping
Peak Output Power	FHSS	GFSK	2 Mbps	Low/Middle/High
Occupied Bandwidth	FHSS	GFSK	2 Mbps	Low/Middle/High
Carrier Frequency Separation	FHSS	GFSK	2 Mbps	Hopping
Time of Occupancy (Dwell time)	FHSS	GFSK	2 Mbps	Hopping
Conducted Spurious Emission	FHSS	GFSK	2 Mbps	Low/Middle/High
Conducted Emission	FHSS	GFSK	2 Mbps	Low/Middle/High
Radiated Emission	FHSS	GFSK	2 Mbps	Low/Middle/High
Band Edge	FHSS	GFSK	2 Mbps	Low/High



### 3 SUMMARY OF TEST RESULTS

#### 3.1 Test Standards

No.	Identity	Document Title
1	47 CFR Part 15, Subpart C (10-1-14 Edition)	Miscellaneous Wireless Communications Services
2	FCC PUBLIC NOTICE DA 00-705 (Mar. 30, 2000)	Filling and Measurement Guidelines for Frequency Hopping Spread Spectrum Systems
3	ANSI C63.10-2013	American National Standard for Testing Unlicensed Wireless Devices

#### 3.2 Verdict

No.	Description	FCC Part No.	Test Result	Verdict
1	Antenna Requirement	15.203	--	Pass <sup>Note 1</sup>
2	Number of Hopping Frequency	15.247(a)	ANNEX A.1	Pass
3	Peak Output Power	15.247(b)	ANNEX A.2	Pass
4	Occupied Bandwidth	15.247(a)	ANNEX A.3	Pass
5	Carrier Frequency Separation	15.247(a)	ANNEX A.4	Pass
6	Time of Occupancy (Dwell time)	15.247(a)	ANNEX A.5	Pass
7	Conducted Spurious Emission & Authorized-band band-edge	15.247(d)	ANNEX A.6	Pass
8	Conducted Emission	15.207	ANNEX A.7	Pass
9	Radiated Spurious Emission	15.209 15.247(d)	ANNEX A.8	Pass
10	Band Edge (Restricted-band band-edge)	15.209 15.247(d)	ANNEX A.9	Pass

Note <sup>1</sup>: The EUT has a permanently and irreplaceable attached antenna, which complies with the requirement FCC 15.203.

## 4 GENERAL TEST CONFIGURATIONS

### 4.1 Test Environments

During the measurement, the normal environmental conditions were within the listed ranges:

Relative Humidity	45% - 55%	
Atmospheric Pressure	100 kPa - 102 kPa	
Temperature	NT (Normal Temperature)	20°C to +25°C
Working Voltage of the EUT	NV (Normal Voltage)	3 V

### 4.2 Test Equipment List

Description	Manufacturer	Model	Serial No.	Cal. Date	Cal. Due
Spectrum Analyzer	ROHDE&SCHWARZ	FSV-30	103118	2016.07.13	2017.07.12
Vector Signal Generator	ROHDE&SCHWARZ	SMBV100A	177746	2016.07.13	2017.07.12
Signal Generator	ROHDE&SCHWARZ	SMB100A	260592	2016.07.13	2017.07.12
Switch Unit with OSP-B157	ROHDE&SCHWARZ	OSP120	101270	2016.07.13	2017.07.12
Spectrum Analyzer	AGILENT	E4440A	MY45304434	2016.11.08	2017.11.07
EMI Receiver	ROHDE&SCHWARZ	ESRP	101036	2016.07.05	2017.07.04
LISN	SCHWARZBECK	NSLK 8127	8127-687	2016.07.05	2017.07.04
Bluetooth Tester	ROHDE&SCHWARZ	CBT	101005	2016.07.13	2017.07.12
Power Splitter	KMW	DCPD-LDC	1305003215	--	--
Power Sensor	ROHDE&SCHWARZ	NRP-Z21	103971	2016.07.13	2017.07.12
Attenuator (20 dB)	KMW	ZA-S1-201	110617091	--	--
Attenuator (6 dB)	KMW	ZA-S1-61	1305003189	--	--
DC Power Supply	ROHDE&SCHWARZ	HMP2020	18141664	2016.07.13	2017.07.12
Temperature Chamber	ANGELANTIONI SCIENCE	NTH64-40A	1310	2016.07.13	2017.07.12
Test Antenna-Loop(9 kHz-30 MHz)	SCHWARZBECK	FMZB 1519	1519-037	2015.07.22	2017.07.21
Test Antenna-Bi-Log(30 MHz-3 GHz)	SCHWARZBECK	VULB 9163	9163-624	2015.07.22	2017.07.21
Test Antenna-Horn(1-18 GHz)	SCHWARZBECK	BBHA 9120D	9120D-1148	2015.07.22	2017.07.21
Test Antenna-Horn(15-26.5 GHz)	SCHWARZBECK	BBHA 9170	9170-305	2015.07.22	2017.07.21
Anechoic Chamber	RAINFORD	9m*6m*6m	N/A	2017.02.21	2019.02.20
Anechoic Chamber	EMC TECHNOLOGY LTD	21.1m*11.6m*7.35m	N/A	2016.08.09	2018.08.08
Shielded Enclosure	ChangNing	CN-130701	130703	--	--
Signal Generator	ROHDE&SCHWARZ	SMB100A	177746	2016.07.13	2017.07.12
Power Amplifier	OPHIR RF	5225F	1037	2017.02.17	2018.02.16
Power Amplifier	OPHIR RF	5273F	1016	2017.02.17	2018.02.16
Directional Coupler	Werlantone	C5982-10	109275	N/A	N/A

Description	Manufacturer	Model	Serial No.	Cal. Date	Cal. Due
Directional Coupler	Werlantone	CHP-273E	S00801z-01	N/A	N/A
Feld Strength Meter	Narda	EP601	511WX51129	2017.02.23	2018.02.22
Mouth Simulator	B&K	4227	2423931	2016.11.15	2017.11.14
Sound Calibrator	B&K	4231	2430337	2016.11.09	2017.11.08
Sound Level Meter	B&K	NL-20	00844023	2016.11.11	2017.11.10
Ear Simulator	B&K	4185	2409449	2016.11.15	2017.11.14
Ear Simulator	B&K	4195	2418189	2016.11.15	2017.11.14
Audio analyzer	B&K	UPL 16	100129	2016.11.08	2017.11.07

### 4.3 Description of Test Setup

#### 4.3.1 For Antenna Port Test



(Diagram 1)

#### 4.3.2 For AC Power Supply Port Test

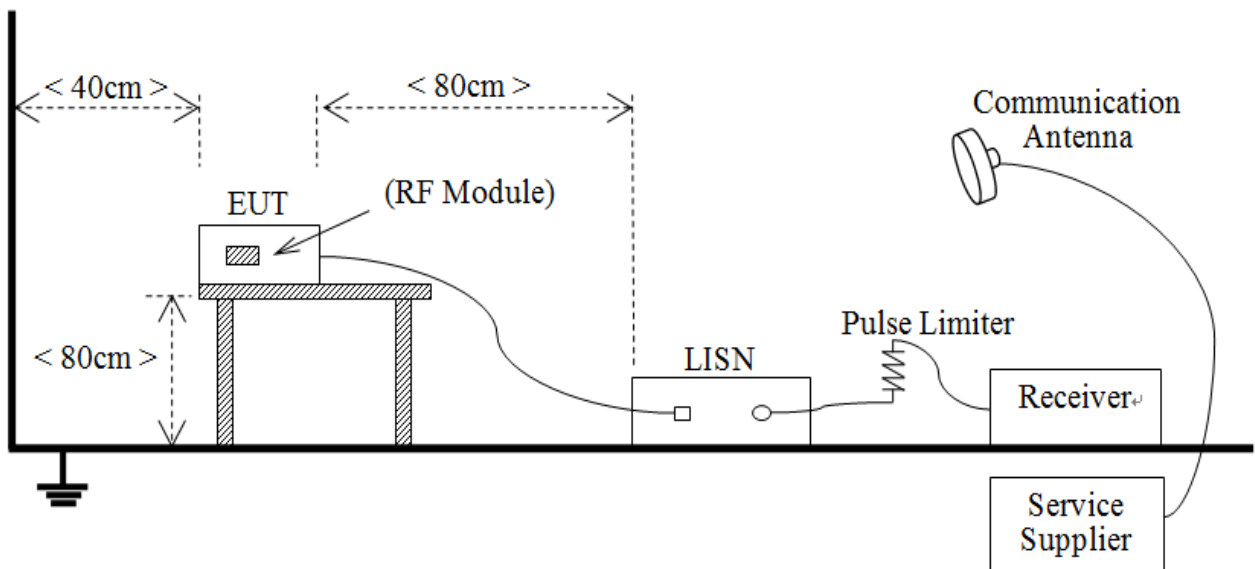

(Diagram 2)

4.3.3 For Radiated Test (Below 30 MHz)

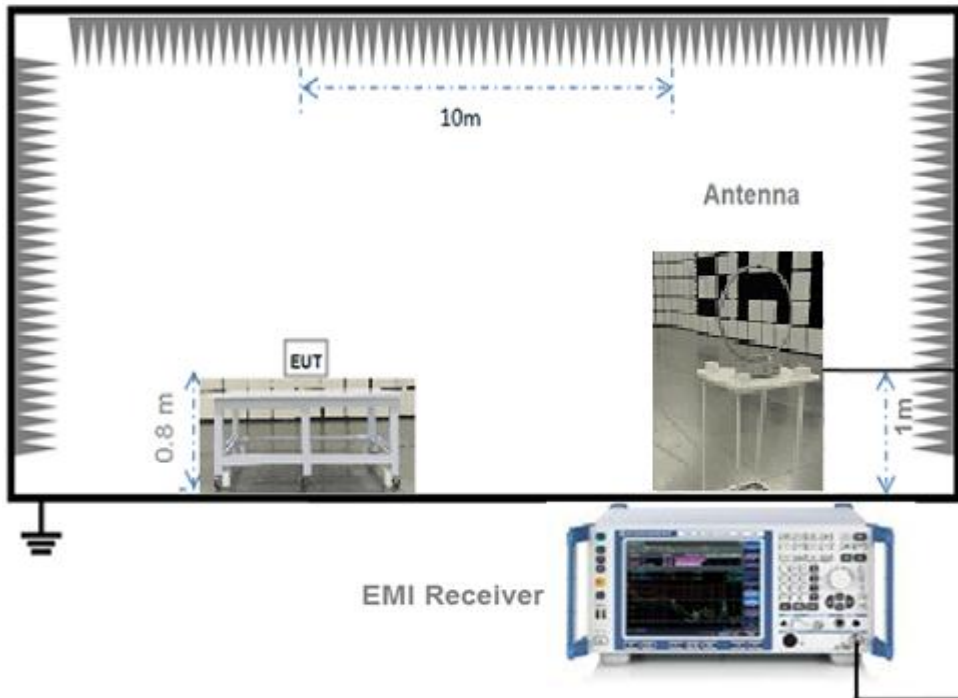

(Diagram 3)

4.3.4 For Radiated Test (30 MHz-1 GHz)

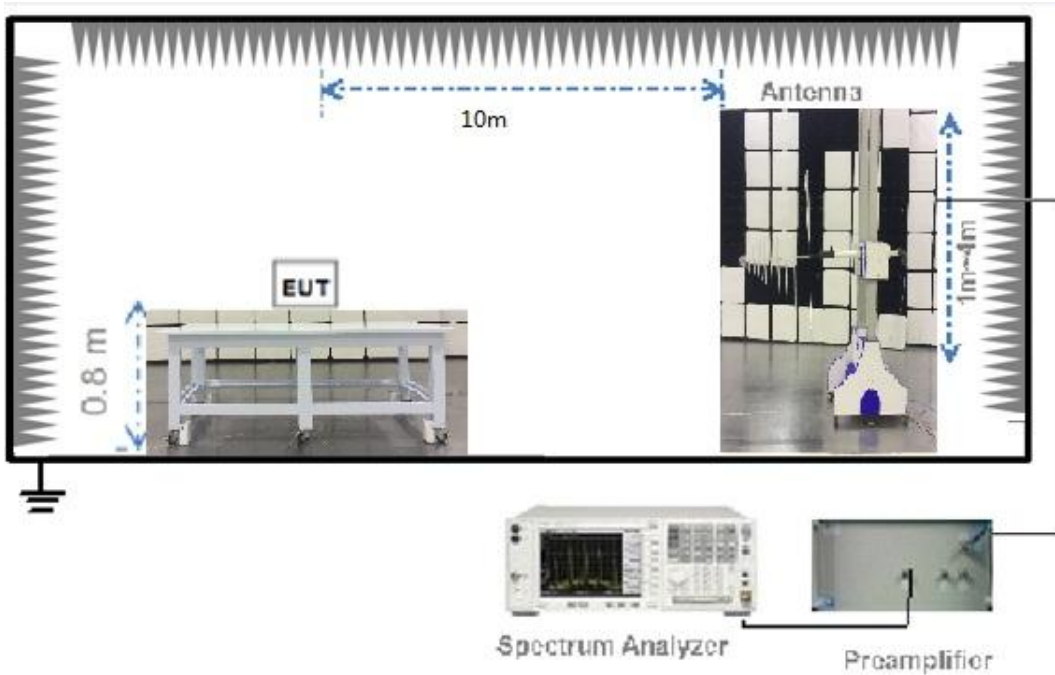

(Diagram 4)

#### 4.3.5 For Radiated Test (Above 1 GHz)

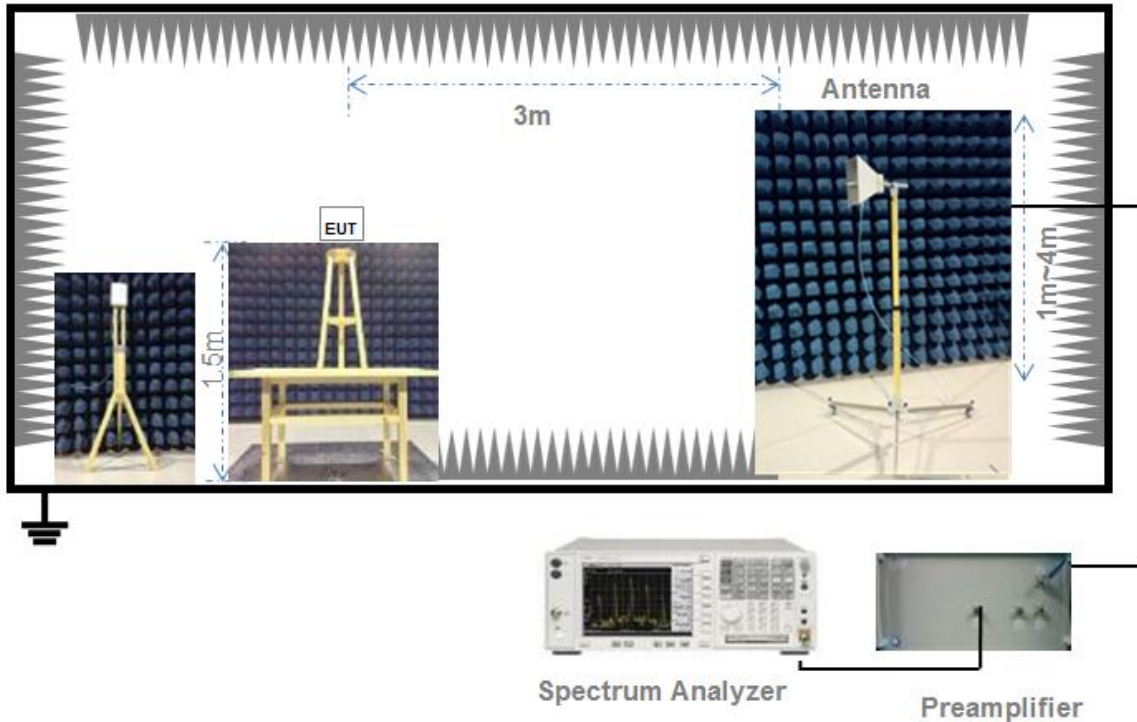

(Diagram 5)

### 4.4 Measurement Results Explanation Example

#### 4.4.1 For conducted test items:

The offset level is set in the spectrum analyzer to compensate the RF cable loss and attenuator between EUT conducted output port and spectrum analyzer. With the offset compensation, the spectrum analyzer reading level is exactly the EUT RF output level.

The spectrum analyzer offset is derived from RF cable loss and attenuator factor.

Offset = RF cable loss + attenuator factor.

#### 4.4.2 For radiated band edges and spurious emission test:

Per part 15.35(c), the EUT Bluetooth average emission level could be determined by the peak emission level applying duty cycle correction factor, to represent averaging over the whole pulse train.

The average level is derived from the peak level corrected with "Duty cycle correction factor".

Average Emission Level (dBuV/m) = Peak Emission Level (dBuV/m) + Duty cycle correction factor (dB)

Duty cycle correction factor (dB) =  $20 * \log(\text{Duty cycle})$ .

Duty cycle = on time / 100 milliseconds

On time = dwell time \* hopping number in 100 ms

For example: bluetooth with dwell time 2.9 ms and 3 hops in 100 ms, then

Duty cycle correction factor (dB) =  $20 * \log((2.9 * 3) / 100) = -21.21 \text{ dB}$

Following shows an average computation example with duty cycle correction factor = -21.21 dB, and the peak emission level is 45.61 dBuV/m.

Example:

Average Emission Level (dBuV/m) = Peak Emission Level (dBuV/m) + duty cycle correction factor (dB)  
 =  $45.61 + (-21.21) = 24.4 \text{ (dBuV/m)}$

## 5 TEST ITEMS

### 5.1 Antenna Requirements

#### 5.1.1 Standard Applicable

FCC §15.203 & 15.247(b); RSS-247, 5.4 (6)

An intentional radiator shall be designed to ensure that no antenna other than that furnished by the responsible party shall be used with the device. The use of a permanently attached antenna or of an antenna that uses a unique coupling to the intentional radiator shall be considered sufficient to comply with the provisions of this section. The manufacturer may design the unit so that a broken antenna can be replaced by the user, but the use of a standard antenna jack or electrical connector is prohibited. This requirement does not apply to carrier current devices or to devices operated under the provisions of § 15.211, § 15.213, § 15.217, § 15.219, or § 15.221. Further, this requirement does not apply to intentional radiators that must be professionally installed, such as perimeter protection systems and some field disturbance sensors, or to other intentional radiators which, in accordance with § 15.31(d), must be measured at the installation site. However, the installer shall be responsible for ensuring that the proper antenna is employed so that the limits in this part are not exceeded.

If directional gain of transmitting antennas is greater than 6 dBi, the power shall be reduced by the same level in dB comparing to gain minus 6 dBi. For the fixed point-to-point operation, the power shall be reduced by one dB for every 3 dB that the directional gain of the antenna exceeds 6 dBi. The use of a permanently attached antenna or of an antenna that uses a unique coupling to the intentional radiator shall be considered sufficient to comply with the FCC rule.

#### 5.1.2 Antenna Anti-Replacement Construction

The Antenna Anti-Replacement as following method:

Protected Method	Description
The antenna is An embedded-in	The antenna is welded on the mainboard, can't be replaced by the consumer

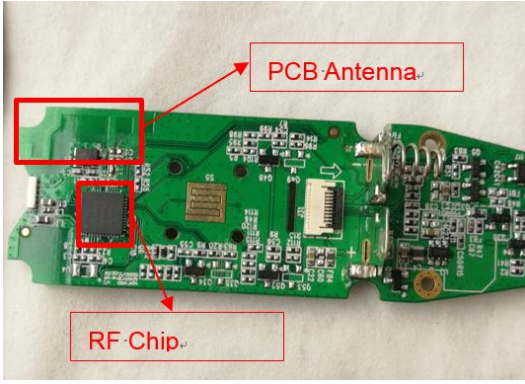
Reference Documents	Item
Photo	

#### 5.1.3 Antenna Gain

The antenna peak gain of EUT is less than 6 dBi. Therefore, it is not necessary to reduce maximum peak output power limit.

## 5.2 Number of Hopping Frequency

### 5.2.1 Limit

FCC §15.247(a) (1) (iii); RSS-247, 5.1 (4)

Frequency hopping systems operating in the 2400 MHz to 2483.5 MHz bands shall use at least 15 hopping frequencies.

### 5.2.2 Test Setup

See section 4.4.1 for test setup description for the antenna port. The photo of test setup please refer to ANNEX B.

### 5.2.3 Test Procedure

The EUT must have its hopping function enabled. Use the following spectrum analyzer settings:

Span = the frequency band of operation

RBW  $\geq$  1% of the span

VBW  $\geq$  RBW

Sweep = auto

Detector function = peak

Trace = max hold

Allow the trace to stabilize

### 5.2.4 Test Result

Please refer to ANNEX A.1.

## 5.3 Peak Output Power

### 5.3.1 Test Limit

FCC § 15.247(b)

For frequency hopping systems operating in the 2400-2483.5 MHz band employing at least 75 non-overlapping hopping channels. For all other frequency hopping systems in the 2400-2483.5 MHz band: 0.125 watts.

RSS-247, 5.4 (2)

For FHSs operating in the band 2400-2483.5 MHz, the maximum peak conducted output power shall not exceed 1.0 W and the e.i.r.p. shall not exceed 4 W if the hopset uses 75 or more hopping channels; the maximum peak conducted output power shall not exceed 0.125 W and the e.i.r.p. shall not exceed 0.5 W if the hopset uses less than 75 hopping channels (see Section 5.4(5) for exceptions).

### 5.3.2 Test Setup

See section 4.4.1 for test setup description for the antenna port. The photo of test setup please refer to ANNEX B.

### 5.3.3 Test Procedure

The Bluetooth Module operates at hopping-off test mode. The lowest, middle and highest channels are selected to perform testing to verify the conducted RF output peak power of the Module.

Use the following spectrum analyzer settings:

Span = approximately 5 times the 20 dB bandwidth, centered on a hopping channel

RBW > the 20 dB bandwidth of the emission being measured

VBW  $\geq$  RBW

Sweep = auto

Detector function = peak

Trace = max hold

Allow the trace to stabilize.

### 5.3.4 Test Result

Please refer to ANNEX A.2.



## 5.4 Occupied Bandwidth

### 5.4.1 Limit

FCC §15.247(a); RSS-247, 5.1 (1)

Measurement of the 20dB bandwidth of the modulated signal.

### 5.4.2 Test Setup

See section 4.4.1 for test setup description for the antenna port. The photo of test setup please refer to ANNEX B.

### 5.4.3 Test Procedure

Use the following spectrum analyzer settings:

Span = approximately 2 to 3 times the 20 dB bandwidth, centered on a hopping channel

RBW  $\geq$  1% of the 20 dB bandwidth

VBW  $\geq$  RBW

Sweep = auto

Detector function = peak

Trace = max hold

The EUT should be transmitting at its maximum data rate, Allow the trace to stabilize.

### 5.4.4 Test Result

Please refer to ANNEX A.3.

## 5.5 Carrier Frequency Separation

### 5.5.1 Limit

FCC §15.247(a); RSS-247, 5.1 (2)

Frequency hopping systems shall have hopping channel carrier frequencies separated by a minimum of 25 kHz or the 20 dB bandwidth of the hopping channel, whichever is greater. Alternatively, Frequency hopping systems shall have hopping channel carrier frequencies separated by a minimum of 25 kHz or two-thirds of the 20 dB bandwidth of the hopping channel, whichever is greater, provided the systems operate with an output power no greater than 125 mW.

### 5.5.2 Test Setup

See section 4.4.1 for test setup description for the antenna port. The photo of test setup please refer to ANNEX B.

### 5.5.3 Test Procedure

The EUT must have its hopping function enabled. Use the following spectrum analyzer settings:

Span = wide enough to capture the peaks of two adjacent channels

Resolution (or IF) Bandwidth (RBW)  $\geq$  1% of the span

Video (or Average) Bandwidth (VBW)  $\geq$  RBW

Sweep = auto

Detector function = peak

Trace = max hold

Allow the trace to stabilize. Use the marker-delta function to determine the separation between the peaks of the adjacent channels.

### 5.5.4 Test Result

Please refer to ANNEX A.4.

## 5.6 Time of Occupancy (Dwell time)

### 5.6.1 Limit

FCC §15.247(a); RSS-247, 5.1 (4)

Frequency hopping systems in the 2400 MHz - 2483.5 MHz band shall use at least 15 non-overlapping channels. The average time of occupancy on any channel shall not be greater than 0.4 seconds within a period of 0.4 seconds multiplied by the number of hopping channels employed. Frequency hopping systems may avoid or suppress transmissions on a particular hopping frequency provided that a minimum of 15 channels are used.

### 5.6.2 Test Setup

See section 4.4.1 for test setup description for the antenna port. The photo of test setup please refer to ANNEX B.

### 5.6.3 Test Procedure

The lowest, middle and highest channels are selected to perform testing to record the dwell time of each occupation measured in this channel, which is called Pulse Time here.

### 5.6.4 Test Result

Please refer to ANNEX A.5

## 5.7 Conducted Spurious Emission & Authorized-band band-edge

### 5.7.1 Limit

FCC §15.247(d); RSS-247, 5.5

In any 100 kHz bandwidth outside the frequency band in which the spread spectrum or digitally modulated intentional radiator is operating, the radio frequency power that is produced by the intentional radiator shall be at least 20 dB below that in the 100 kHz bandwidth within the band that contains the highest level of the desired power, based on either an RF conducted or a radiated measurement.

### 5.7.2 Test Setup

See section 4.4.1 for test setup description for the antenna port. The photo of test setup please refer to ANNEX B.

### 5.7.3 Test Procedure

Use the following spectrum analyzer settings:

Span = wide enough to capture the peak level of the in-band emission and all spurious emissions (e.g., harmonics) from the lowest frequency generated in the EUT up through the 10th harmonic. Typically, several plots are required to cover this entire span.

RBW = 100 kHz

VBW  $\geq$  RBW

Sweep = auto

Detector function = peak

Trace = max hold

Allow the trace to stabilize

### 5.7.4 Test Result

Please refer to ANNEX A.6.

## 5.8 Conducted Emission

### 5.8.1 Limit

FCC §15.207; RSS-GEN, 8.8

For an intentional radiator that is designed to be connected to the public utility (AC) power line, the radio frequency voltage that is conducted back onto the AC power line on any frequency within the band 150 kHz to 30 MHz shall not exceed the limits in the following table, as measured using a 50 $\mu$ H/50 $\Omega$  line impedance stabilization network (LISN).

Frequency range (MHz)	Conducted Limit (dB $\mu$ V)	
	Quai-peak	Average
0.15 - 0.50	66 to 56	56 to 46
0.50 - 5	56	46
0.50 - 30	60	50

### 5.8.2 Test Setup

See section 4.4.2 for test setup description for the AC power supply port. The photo of test setup please refer to ANNEX B.

### 5.8.3 Test Procedure

The maximum conducted interference is searched using Peak (PK), if the emission levels more than the AV and QP limits, and that have narrow margins from the AV and QP limits will be re-measured with AV and QP detectors. Tests for both L phase and N phase lines of the power mains connected to the EUT are performed. Refer to recorded points and plots below.

### 5.8.4 Test Result

Please refer to ANNEX A.7.

## 5.9 Radiated Spurious Emission

### 5.9.1 Limit

FCC §15.209&15.247(d); RSS-247, 5.5

Radiated emission outside the frequency band attenuation below the general limits specified in FCC section 15.209(a) is not required. In addition, radiated emissions which fall in the restricted bands, as defined in FCC section 15.205(a), must also comply with the radiated emission limits specified in FCC section 15.209(a).

According to FCC section 15.209 (a), except as provided elsewhere in this subpart, the emissions from an intentional radiator shall not exceed the field strength levels specified in the following table:

Frequency (MHz)	Field Strength ( $\mu\text{V}/\text{m}$ )	Measurement Distance (m)
0.009 - 0.490	2400/F(kHz)	300
0.490 - 1.705	24000/F(kHz)	30
1.705 - 30.0	30	30
30 - 88	100	3
88 - 216	150	3
216 - 960	200	3
Above 960	500	3

Note:

1. Field Strength (dB $\mu\text{V}/\text{m}$ ) =  $20 \cdot \log[\text{Field Strength } (\mu\text{V}/\text{m})]$ .
2. In the emission tables above, the tighter limit applies at the band edges.
3. For Above 1000 MHz, the emission limit in this paragraph is based on measurement instrumentation employing an average detector, measurement using instrumentation with a peak detector function, corresponding to 20dB above the maximum permitted average limit.
4. For above 1000 MHz, limit field strength of harmonics: 54dBuV/m@3m (AV) and 74dBuV/m@3m (PK).

### 5.9.2 Test Setup

See section 4.4.3 to 4.4.5 for test setup description for the antenna port. The photo of test setup please refer to ANNEX B.

### 5.9.3 Test Procedure

The measurement frequency range is from 9 kHz to the 10th harmonic of the fundamental frequency. The Turn Table is actuated to turn from 0° to 360°, and both horizontal and vertical polarizations of the Test Antenna are used to find the maximum radiated power. Mid channels on all channel bandwidth verified. Only the worst RB size/offset presented.

The power of the EUT transmitting frequency should be ignored.

All Spurious Emission tests were performed in X, Y, Z axis direction. And only the worst axis test condition was recorded in this test report.

Use the following spectrum analyzer settings:

Span = wide enough to fully capture the emission being measured

RBW = 1 MHz for  $f \geq 1$  GHz, 100 kHz for  $f < 1$  GHz

VBW  $\geq$  RBW

Sweep = auto

Detector function = peak

Trace = max hold

For measurement below 1GHz, If the emission level of the EUT measured by the peak detector is 3 dB lower than the applicable limit, the peak emission level will be reported, Otherwise, the emission measurement will be repeated using the quasi-peak detector and reported.

#### 5.9.4 Test Result

Please refer to ANNEX A.8.

## 5.10 Band Edge (Restricted-band band-edge)

### 5.10.1 Limit

FCC §15.209&15.247(d); RSS-247, 5.5

Radiated emission outside the frequency band attenuation below the general limits specified in FCC section 15.209(a) is not required. In addition, radiated emissions which fall in the restricted bands, as defined in FCC section 15.205(a), must also comply with the radiated emission limits specified in FCC section 15.209(a).

### 5.10.2 Test Setup

See section 4.4.3 to 4.4.5 for test setup description for the antenna port. The photo of test setup please refer to ANNEX B.

### 5.10.3 Test Procedure

The measurement frequency range is from 9 kHz to the 10th harmonic of the fundamental frequency. The Turn Table is actuated to turn from 0° to 360°, and both horizontal and vertical polarizations of the Test Antenna are used to find the maximum radiated power. Mid channels on all channel bandwidth verified. Only the worst RB size/offset presented.

The power of the EUT transmitting frequency should be ignored.

All Spurious Emission tests were performed in X, Y, Z axis direction. And only the worst axis test condition was recorded in this test report.

Use the following spectrum analyzer settings:

Span = wide enough to fully capture the emission being measured

RBW = 1 MHz for  $f \geq 1$  GHz, 100 kHz for  $f < 1$  GHz

VBW  $\geq$  RBW

Sweep = auto

Detector function = peak

Trace = max hold

For measurement below 1GHz, If the emission level of the EUT measured by the peak detector is 3 dB lower than the applicable limit, the peak emission level will be reported, Otherwise, the emission measurement will be repeated using the quasi-peak detector and reported.

### 5.10.4 Test Result

Please refer to ANNEX A.9.



# ANNEX A TEST RESULT

## A.1 Number of Hopping Frequency

### Test Data

ANT 1

Test Mode	Frequency Block (MHz)	Measured Channel Numbers	Min. Limit	Verdict
GFSK	2400 - 2483.5	15	15	Pass

### Test plots

GFSK 2.4 GHz ~ 2.4835 GHz

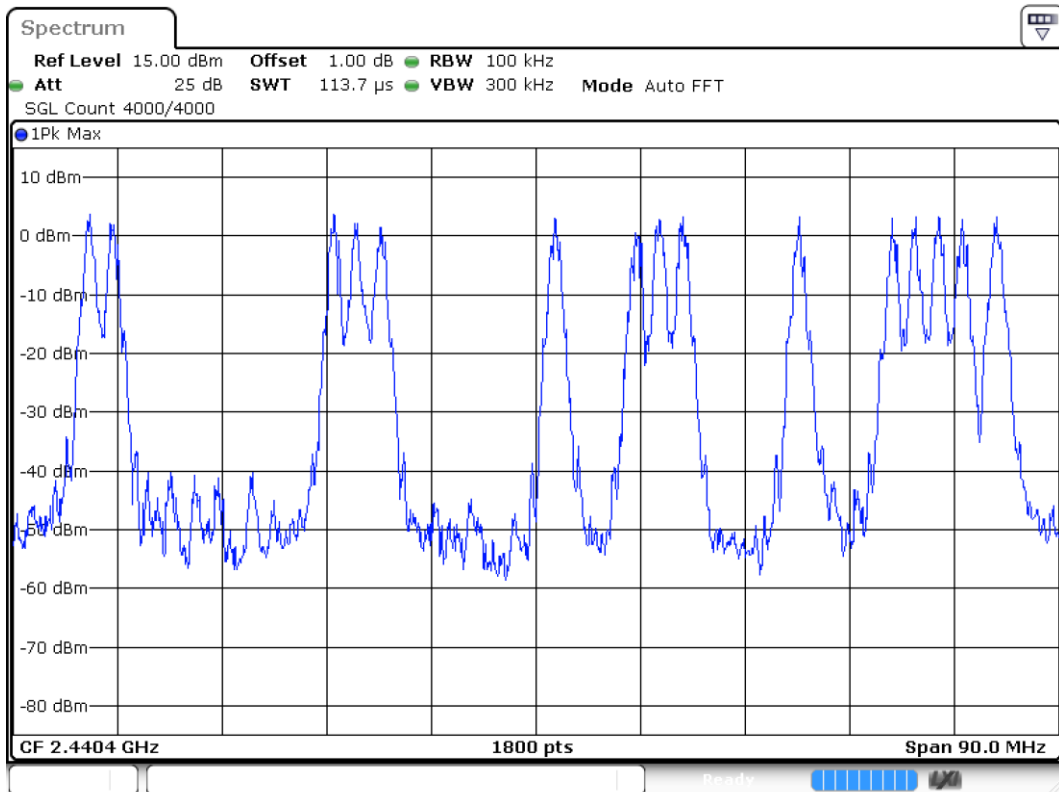

Date: 8.JUN.2017 22:39:12

## A.2 Peak Output Power

### Peak Power Test Data

Channel	Measured Output Peak Power		Limit		Verdict
	dBm	mW	dBm	mW	
Low	4.29	2.69	21	125	Pass
Middle	4.20	2.63			Pass
High	4.05	2.54			Pass

### Test plots

#### GFSK LOW CHANNEL

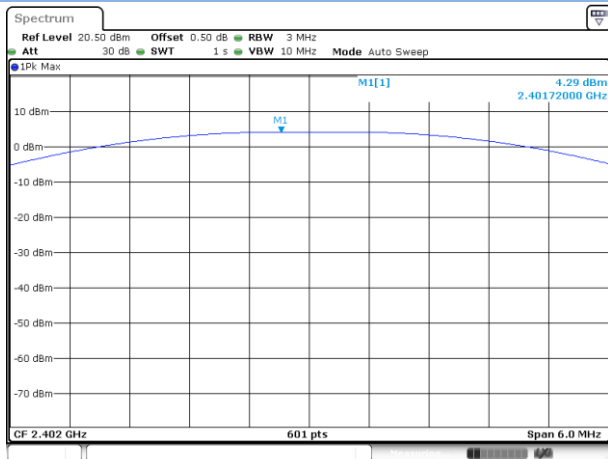

Date: 8 JUN 2017 17:18:32

#### GFSK MIDDLE CHANNEL

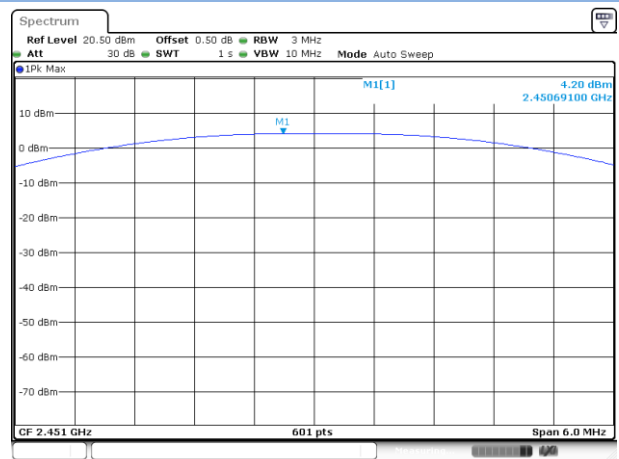

Date: 8 JUN 2017 17:25:34

#### GFSK HIGH CHANNEL

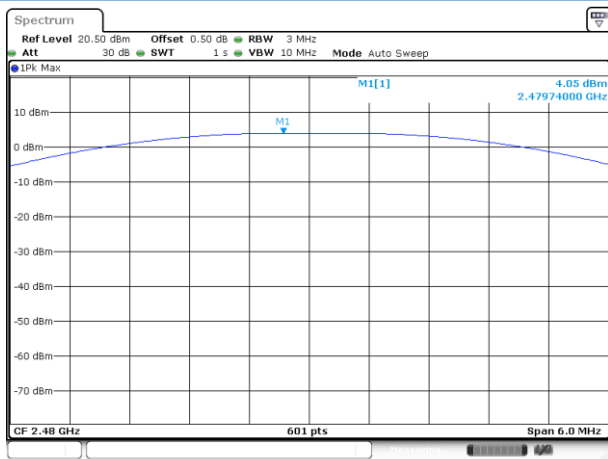

Date: 8 JUN 2017 17:29:46

# A.3 20 dB and 99% bandwidth

## Test Data

GFSK Mode:

Channel	20 dB Bandwidth (MHz)	99% Bandwidth (MHz)
Low	1.898	1.585
Middle	2.058	1.597
High	2.065	1.609

## Test plots

### 20 dB Bandwidth

#### GFSK LOW CHANNEL

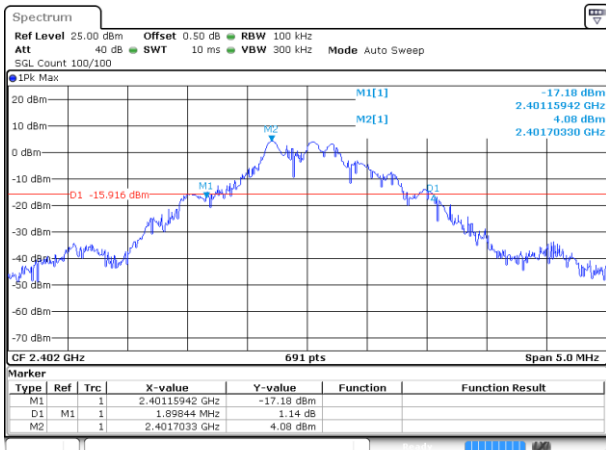

Date: 8 JUN 2017 17:18:45

#### GFSK MIDDLE CHANNEL



Date: 8 JUN 2017 17:25:40

#### GFSK HIGH CHANNEL

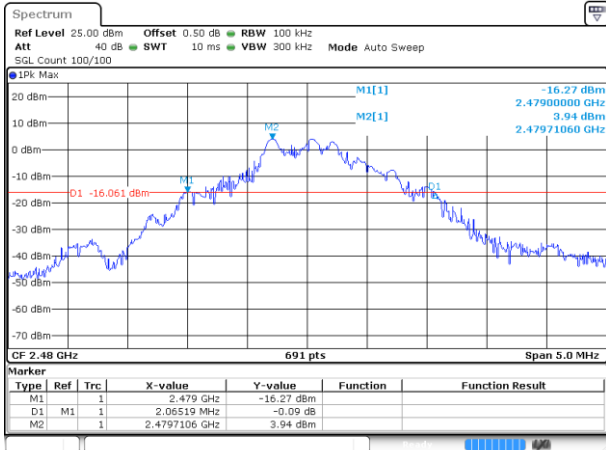

Date: 8 JUN 2017 17:29:51

# 99% Bandwidth

## GFSK LOW CHANNEL

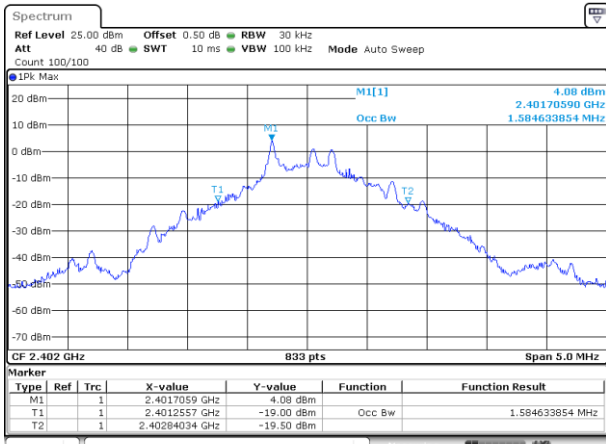

## GFSK MIDDLE CHANNEL

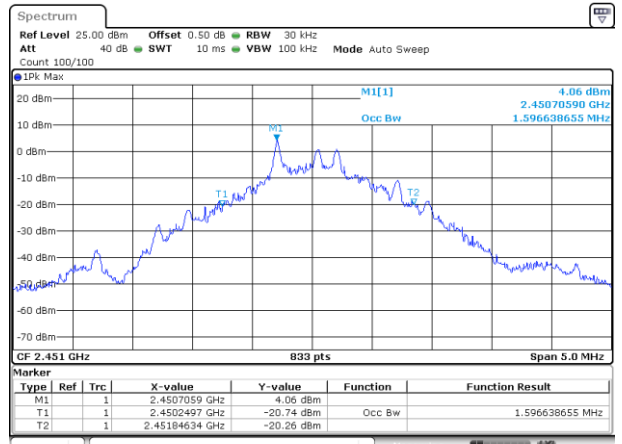

## GFSK HIGH CHANNEL

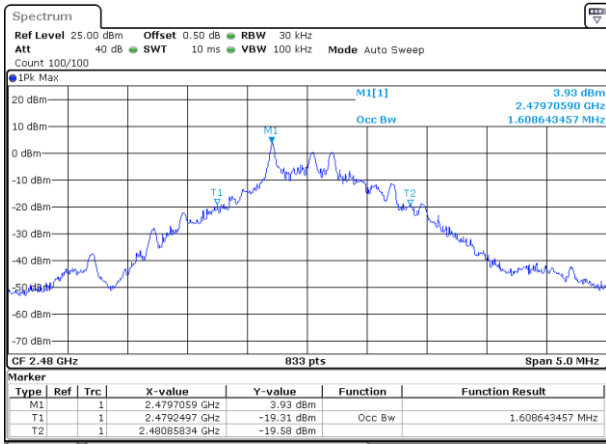

## A.4 Hopping Frequency Separation

### Test Data

Mode	Frequency separation (MHz)	Max 20 dB Bandwidth (MHz)	Two-thirds of the 20 dB bandwidth (MHz)	Verdict
GFSK	1.997	2.065	1.377	Pass

### Test Plots

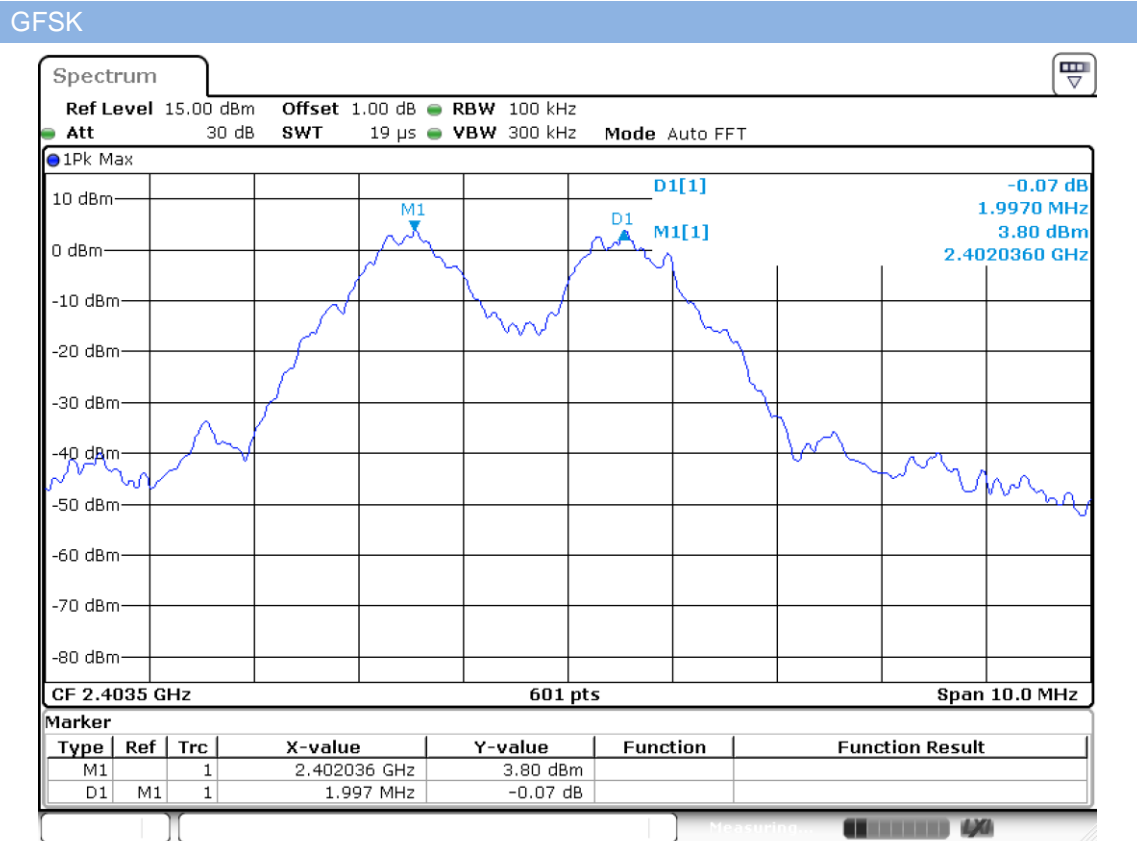

Date: 8.JUN.2017 22:41:25

# A.5 Average Time of Occupancy

## Test Data

Note: Average time (ms) = Pulse Width (ms) × Number of hopping channels with 0.4 seconds × number of hopping channels.

Pulse Width (ms)	Number with period	Average time (ms)	Limit (ms)	Verdict
0.091	226	20.566	400	Pass

## Test Plots

### Single

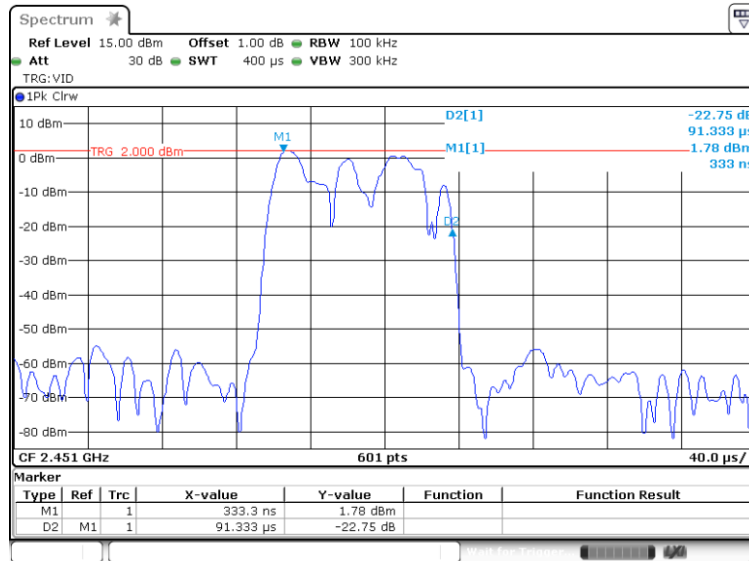

Date: 8 JUN 2017 22:47:20

### Number with period

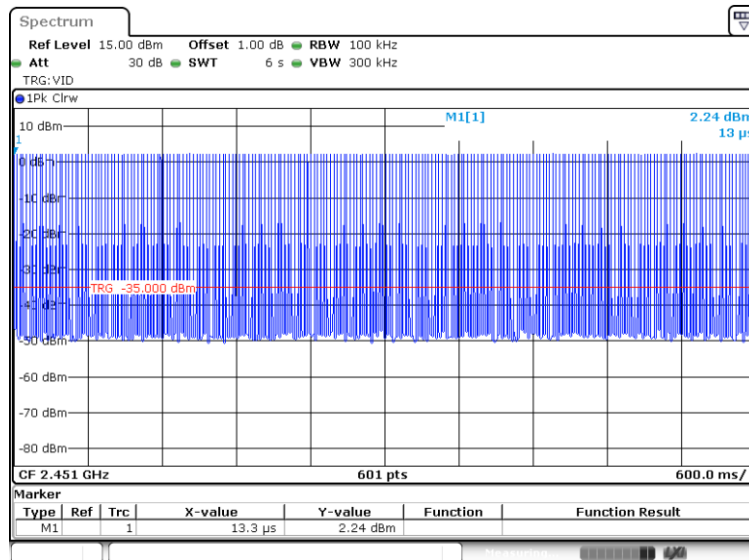

Date: 8 JUN 2017 22:44:35

# A.6 Conducted Spurious Emissions & Authorized-band band-edge

## Test Data

GFSK Mode:

Channel	Measured Max. Out of Band Emission (dBm)	Limit (dBm)		Verdict
		Carrier Level	Calculated 20 dBc Limit	
Low	-37.50	4.23	-15.77	Pass
Middle	-38.19	4.08	-15.92	Pass
High	-37.92	4.01	-15.99	Pass

Hopping Mode:

Channel	Measured Max. Out of Band Emission (dBm)	Limit (dBm)		Verdict
		Carrier Level	Calculated 20 dBc Limit	
Low	-38.00	3.80	-16.2	Pass

## Test Plots

GFSK LOW CHANNEL, CARRIER LEVEL

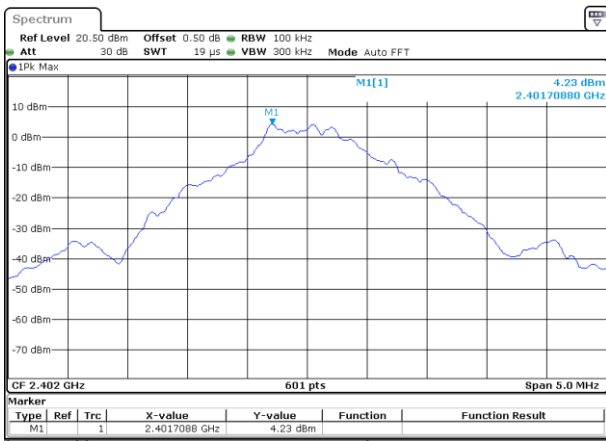

Date: 8 JUN 2017 17:21:49

GFSK LOW CHANNEL, BAND EDGE

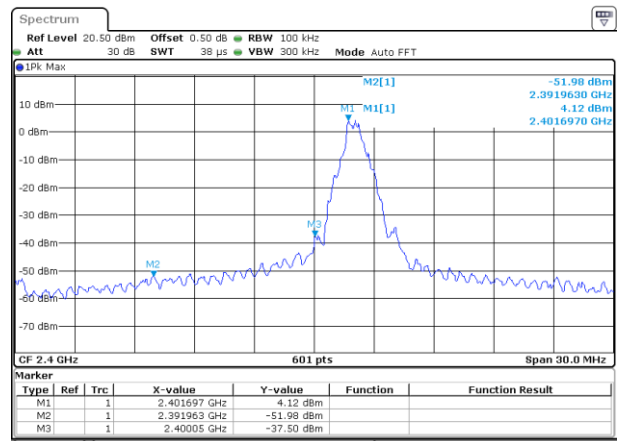

Date: 8 JUN 2017 17:23:51

GFSK LOW CHANNEL, SPURIOUS 30 MHz ~ 3 GHz

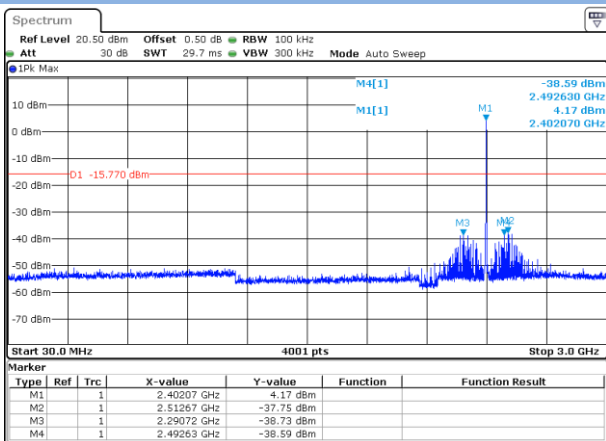

Date: 8 JUN 2017 17:22:29

GFSK LOW CHANNEL, SPURIOUS 3 GHz ~ 25 GHz

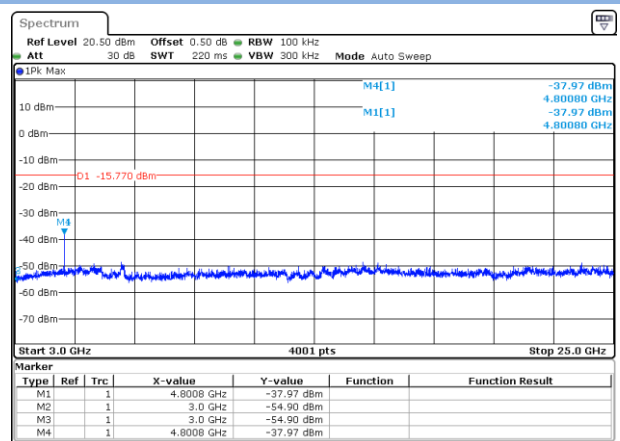

Date: 8 JUN 2017 17:22:49

## GFSK MIDDLE CHANNEL, CARRIER LEVEL

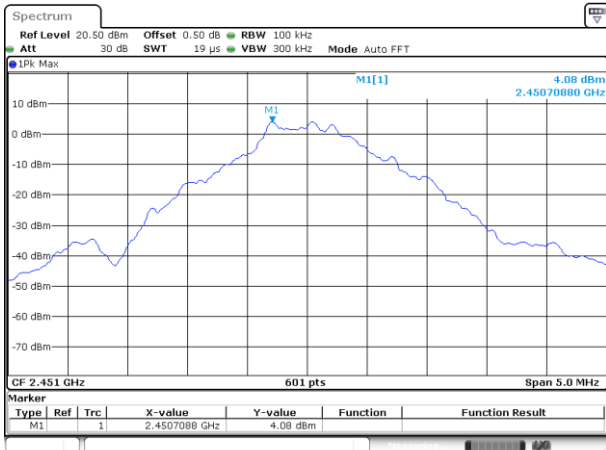

Date: 8 JUN 2017 17:25:58

## GFSK MIDDLE CHANNEL, SPURIOUS 30 MHz ~ 3 GHz

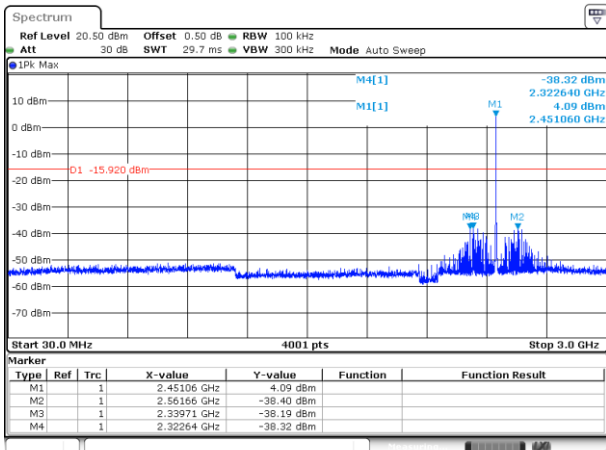

Date: 8 JUN 2017 17:26:33

## GFSK MIDDLE CHANNEL, SPURIOUS 3 GHz ~ 25 GHz

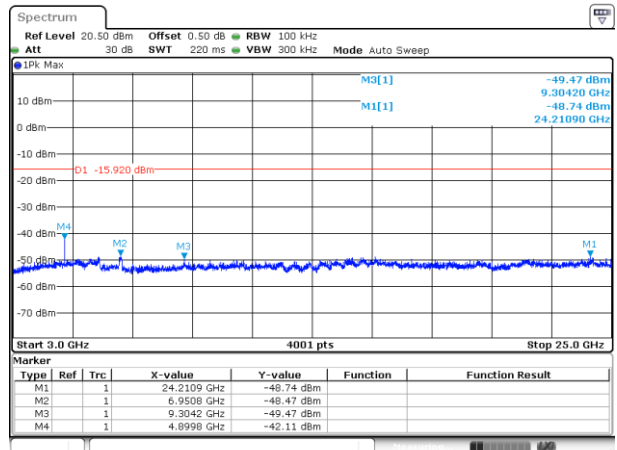

Date: 8 JUN 2017 17:27:16

## GFSK HIGH CHANNEL, CARRIER LEVEL

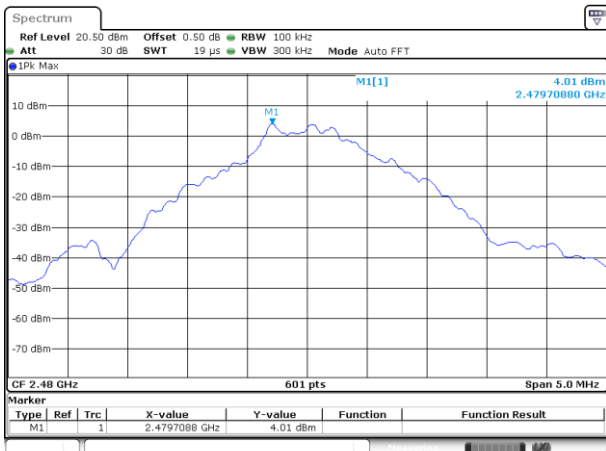

Date: 8 JUN 2017 17:31:55

## GFSK HIGH CHANNEL, BAND EDGE

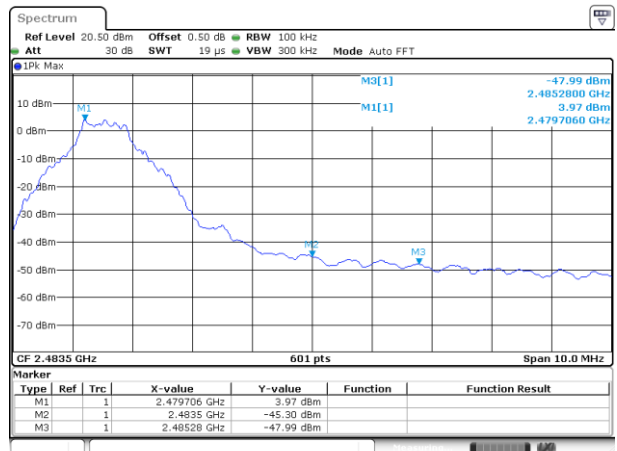

Date: 8 JUN 2017 17:36:45



## GFSK HIGH CHANNEL , SPURIOUS 30 MHz ~ 3 GHz

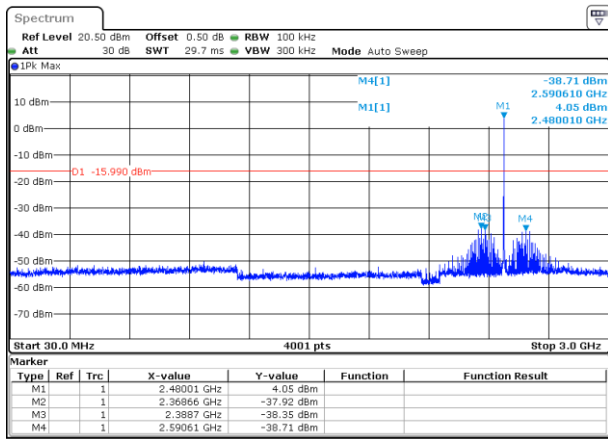

Date: 8 JUN 2017 17:32:26

## GFSK HIGH CHANNEL , SPURIOUS 3 GHz ~ 25 GHz

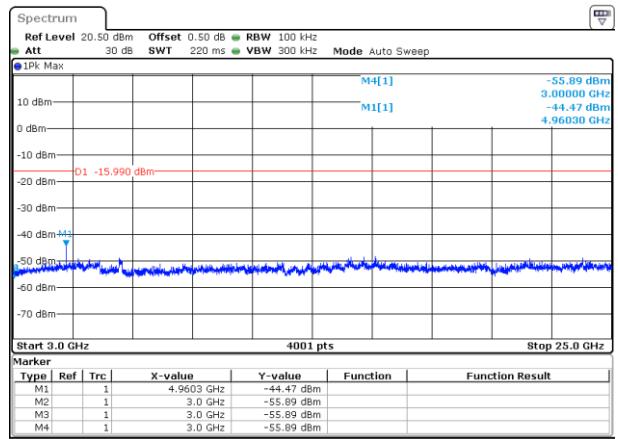

Date: 8 JUN 2017 17:32:40

## Hopping Mode:

### GFSK HOPPING, CARRIER LEVEL

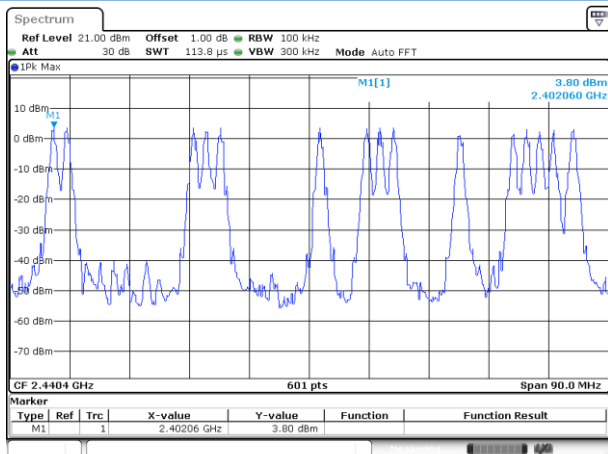

Date: 8 JUN 2017 22:52:28

### GFSK HOPPING BAND EDGE (LOW)

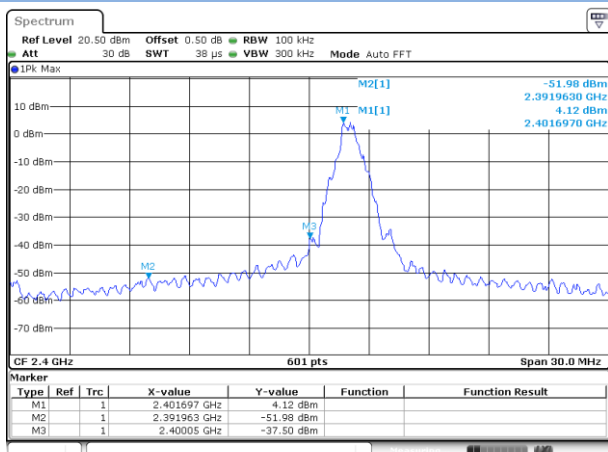

Date: 8 JUN 2017 17:23:51

### GFSK HOPPING BAND EDGE (HIGH)

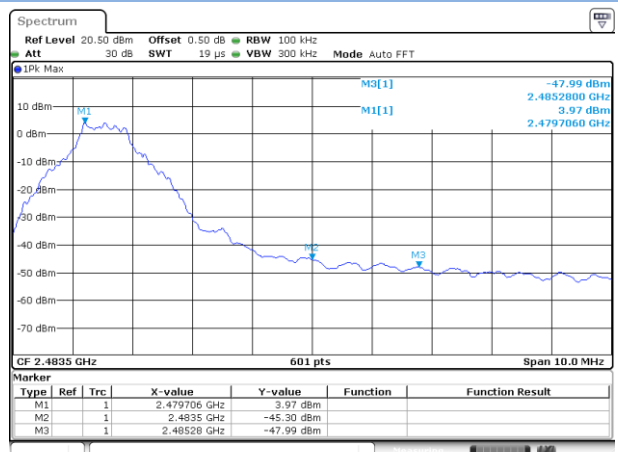

Date: 8 JUN 2017 17:36:45

GFSK Hopping Mode, SPURIOUS 30 MHz ~ 3 GHz

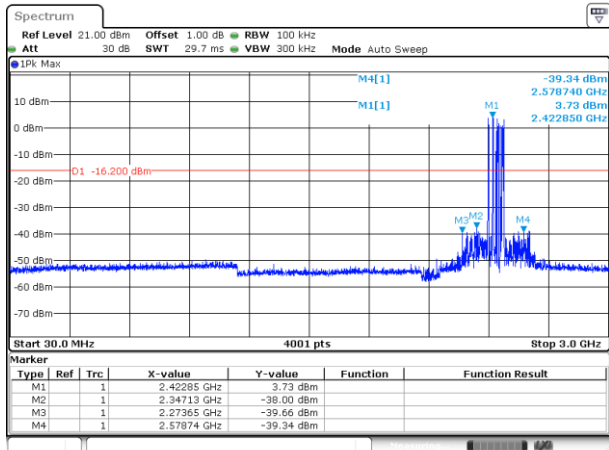

Date: 8 JUN 2017 22:53:51

GFSK Hopping Mode, SPURIOUS 30 3GHz ~ 25 GHz

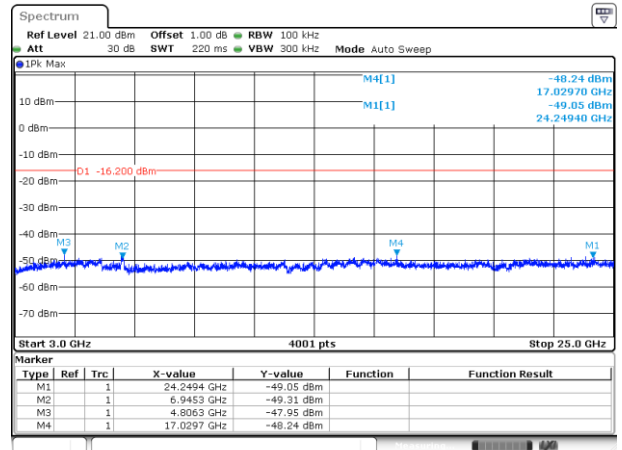

Date: 8 JUN 2017 22:54:18

## A.7 Conducted Emissions

Not applicable. it is supply by battery.

## A.8 Radiated Emission

Note<sup>1</sup>: The symbol of "--" in the table which means not application.

Note<sup>2</sup>: For the test data above 1 GHz, according the ANSI C63.4-2014, where limits are specified for both average and peak (or quasi-peak) detector functions, if the peak (or quasi-peak) measured value complies with the average limit, it is unnecessary to perform an average measurement.

Note<sup>3</sup>: The EUT is working in the Normal link mode for below 1GHz.

### Test Data and Plots

The low frequency, which started from 9 kHz to 30 MHz, was pre-scanned and the result which was 20 dB lower than the limit line per 15.31(o) was not reported.

30 MHz to 1 GHz, ANT V

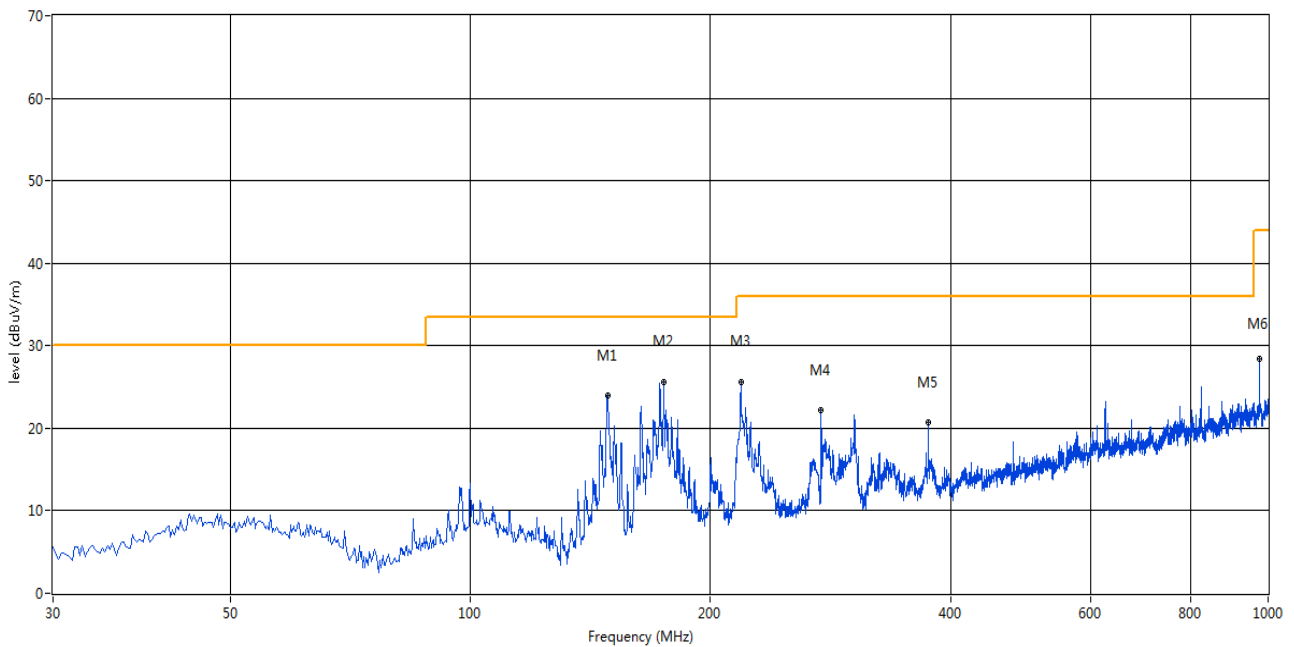

No.	Frequency (MHz)	Results (dBuV/m)	Factor (dB)	Limit (dBuV/m)	Margin (dB)	Detector	Table (o)	Height (cm)	ANT	Verdict
1	148.553	23.92	-18.76	33.5	9.58	Peak	305.00	100	Vertical	Pass
2	174.979	25.63	-17.36	33.5	7.87	Peak	36.00	100	Vertical	Pass
3	218.375	25.63	-14.90	36.0	10.37	Peak	341.00	100	Vertical	Pass
4	274.864	22.13	-13.02	36.0	13.87	Peak	281.00	100	Vertical	Pass
5	374.749	20.67	-10.46	36.0	15.33	Peak	102.00	100	Vertical	Pass
6	974.786	28.37	-0.48	44.0	15.63	Peak	0.00	300	Vertical	Pass

30 MHz to 1 GHz, ANT H

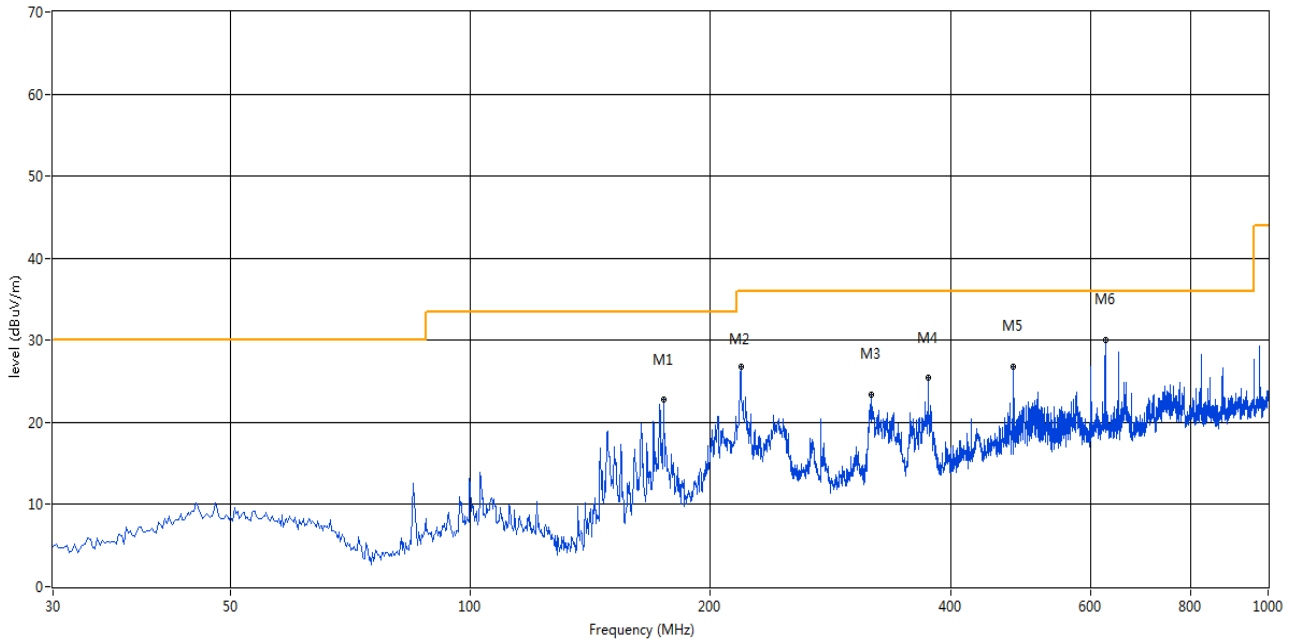

No.	Frequency (MHz)	Results (dBuV/m)	Factor (dB)	Limit (dBuV/m)	Margin (dB)	Detector	Table (o)	Height (cm)	ANT	Verdict
1	174.979	22.73	-17.36	33.5	10.77	Peak	326.00	300	Horizontal	Pass
2	218.375	26.83	-14.90	36.0	9.17	Peak	2.00	300	Horizontal	Pass
3	318.503	23.35	-11.85	36.0	12.65	Peak	360.00	200	Horizontal	Pass
4	374.991	25.39	-10.47	36.0	10.61	Peak	128.00	300	Horizontal	Pass
5	479.968	26.80	-8.21	36.0	9.20	Peak	243.00	200	Horizontal	Pass
6	624.946	30.00	-5.12	36.0	6.00	Peak	113.00	200	Horizontal	Pass

Note 1: The marked spikes near 2400 MHz with circle should be ignored because they are Fundamental signal.

Test Data (1 GHz ~ 10th Harmonic)

1 GHz to 25 GHz, Low channel

No.	Frequency (MHz)	Results (dBuV/m)	Factor (dB)	Limit (dBuV/m)	Margin (dB)	Detector	Table (o)	Height (cm)	ANT	Verdict
1	1626.40	49.62	-6.00	74	24.38	Peak	9.6	150	Vertical	Pass
2	2401.56	87.54	-2.35	74	-13.54	Peak	94.9	150	Vertical	N/A
3	4803.87	51.61	10.39	74	22.39	Peak	279	150	Vertical	Pass
4	11727.95	43.07	14.81	74	30.93	Peak	147.9	150	Vertical	Pass
5	13145.18	44.25	9.23	74	29.75	Peak	105.6	150	Vertical	Pass
6	19000.00	43.76	10.64	74	30.24	Peak	156.3	150	Vertical	Pass

1 GHz to 25 GHz, Low channel

No.	Frequency (MHz)	Results (dBuV/m)	Factor (dB)	Limit (dBuV/m)	Margin (dB)	Detector	Table (o)	Height (cm)	ANT	Verdict
1	2067.10	46.70	-3.82	74	27.30	Peak	30.4	150	Horizontal	Pass
2	2402.02	96.14	-2.35	74	-22.14	Peak	14.3	150	Horizontal	N/A
3**	2529.89	49.95	-2.08	54.0	4.05	AV	100.3	150	Horizontal	Pass
3	2529.89	55.67	-2.08	74	18.33	Peak	100.3	150	Horizontal	Pass
4	9369.38	45.28	14.61	74	28.72	Peak	25.2	150	Horizontal	Pass
5	15256.24	42.42	9.04	74	31.58	Peak	343.8	150	Horizontal	Pass
6	21256.24	46.08	12.16	74	27.92	Peak	348.5	150	Horizontal	Pass

1 GHz to 25 GHz, Middle channel

No.	Frequency (MHz)	Results (dBuV/m)	Factor (dB)	Limit (dBuV/m)	Margin (dB)	Detector	Table (o)	Height (cm)	ANT	Verdict
1	1881.52	48.72	-5.03	74	25.28	Peak	67.4	150	Vertical	Pass
2	2451.02	88.07	-2.77	74	-14.07	Peak	354.2	150	Vertical	N/A
3	4904.96	52.68	10.35	74	21.32	Peak	53.4	150	Vertical	Pass
4	10941.76	47.98	19.29	74	26.02	Peak	73.3	150	Vertical	Pass
5	15079.45	45.95	9.03	74	28.05	Peak	117.2	150	Vertical	Pass
6	20417.64	43.30	10.63	74	30.70	Peak	108.6	150	Vertical	Pass

1 GHz to 25 GHz, Middle channel

No.	Frequency (MHz)	Results (dBuV/m)	Factor (dB)	Limit (dBuV/m)	Margin (dB)	Detector	Table (o)	Height (cm)	ANT	Verdict
1	2066.01	46.19	-3.81	74	27.81	Peak	210.5	150	Horizontal	Pass
2	2450.58	95.86	-2.76	74	-21.86	Peak	304.4	150	Horizontal	N/A
3**	2561.91	50.28	-2.14	54.0	3.72	AV	99	150	Horizontal	Pass
3	2561.91	55.16	-2.14	74	18.84	Peak	99	150	Horizontal	Pass
4	7662.23	48.07	14.35	74	25.93	Peak	171.7	150	Horizontal	Pass
5	14382.70	43.53	9.77	74	30.47	Peak	66.7	150	Horizontal	Pass
6	20128.12	42.88	12.55	74	31.12	Peak	240.7	150	Horizontal	Pass

1 GHz to 25 GHz, High channel

No.	Frequency (MHz)	Results (dBuV/m)	Factor (dB)	Limit (dBuV/m)	Margin (dB)	Detector	Table (o)	Height (cm)	ANT	Verdict
1	2075.99	43.97	-3.78	74	30.03	Peak	278.2	150	Vertical	Pass
2	2480.02	95.81	-2.65	74	-21.81	Peak	205.6	150	Vertical	N/A
3	2588.70	51.28	-1.34	74	22.72	Peak	216.2	150	Vertical	Pass
4	10683.44	46.17	18.89	74	27.83	Peak	321	150	Vertical	Pass
5	15381.03	44.38	9.47	74	29.62	Peak	82.8	150	Vertical	Pass
6	23742.10	45.89	10.70	74	28.12	Peak	212.2	150	Vertical	Pass

1 GHz to 25 GHz, High channel

No.	Frequency (MHz)	Results (dBuV/m)	Factor (dB)	Limit (dBuV/m)	Margin (dB)	Detector	Table (o)	Height (cm)	ANT	Verdict
1	2077.72	43.96	-3.78	74	30.04	Peak	344.7	150	Horizontal	Pass
2	2480.01	96.22	-2.65	74	-22.22	Peak	121.2	150	Horizontal	N/A
3**	2589.99	50.63	-1.37	54.0	3.37	AV	285.2	150	Horizontal	Pass
3	2589.99	56.12	-1.37	74	17.88	Peak	285.2	150	Horizontal	Pass
4	8122.71	50.38	14.24	74	23.62	Peak	23.6	150	Horizontal	Pass
5	15693.01	51.61	9.06	74	22.39	Peak	185.6	150	Horizontal	Pass
6	21565.72	45.74	9.90	74	28.26	Peak	66.5	150	Horizontal	Pass

## Hopping mode

### 1 GHz to 25 GHz, ANT V Hopping

No.	Frequency (MHz)	Results (dBuV/m)	Factor (dB)	Limit (dBuV/m)	Margin (dB)	Detector	Table (o)	Height (cm)	ANT	Verdict
1**	1995.02	31.94	-4.52	54.0	22.06	AV	193.7	150	Vertical	PASS
1	1995.02	55.72	-4.52	74	18.28	Peak	193.7	150	Vertical	PASS
2	2476.58	93.87	-2.68	74	-19.87	Peak	331	150	Vertical	N/A
3	2554.56	51.90	-2.21	74	22.10	Peak	159.6	150	Vertical	PASS
4	6853.58	44.97	20.14	74	29.03	Peak	11	150	Vertical	PASS
5	12937.19	42.41	9.04	74	31.59	Peak	287.6	150	Vertical	PASS
6	21016.64	44.71	9.88	74	29.29	Peak	301.8	150	Vertical	PASS

### 1 GHz to 25 GHz, ANT H Hopping

No.	Frequency (MHz)	Results (dBuV/m)	Factor (dB)	Limit (dBuV/m)	Margin (dB)	Detector	Table (o)	Height (cm)	ANT	Verdict
1	1992.39	48.97	-4.53	74	25.03	Peak	232.1	150	Horizontal	PASS
2	2425.03	95.55	-2.66	74	-21.55	Peak	29.3	150	Horizontal	N/A
3**	4960.32	37.69	10.62	54.0	16.31	AV	64	150	Horizontal	PASS
3	4960.32	55.58	10.62	74	18.42	Peak	64	150	Horizontal	PASS
4	6157.24	49.05	15.24	74	24.95	Peak	355.1	150	Horizontal	PASS
5	15724.21	44.54	9.72	74	29.46	Peak	12.7	150	Horizontal	PASS
6	22753.74	47.01	14.08	74	26.99	Peak	152.5	150	Horizontal	PASS

## A.9 Band Edge (Restricted-band band-edge)

### Test Data

Note 1: The lowest and highest channels are tested to verify the band edge emissions. Please refer to the following the plots for emissions values.

Note 2: The test data all are tested in the vertical and horizontal antenna which the trace is max hold. So these plots have shown the worst case.

Note 3: According the ANSI C63.10-2013, where limits are specified for both average and peak (or quasi-peak) detector functions, if the peak (or quasi-peak) measured value complies with the average limit, it is unnecessary to perform an average measurement.

### Test Plots

Test Mode	Test Channel	Frequency (MHz)	Level (dBuV/m)	Limit Line (dBuV/m)	Margin (dB)	Remark	Verdict
GFSK	Low	2337.8	48.80	74	25.20	PEAK	Pass
		2337.8	N/A	54	N/A	AVERAGE	Pass
GFSK	HIGH	2483.5	50.21	74	23.79	PEAK	Pass
		2483.5	N/A	54	N/A	AVERAGE	Pass
GFSK(Hopping)	Low	2390	47.92	74	26.08	PEAK	Pass
		2390	N/A	54	N/A	AVERAGE	Pass
GFSK(Hopping)	HIGH	2483.5	49.14	74	24.86	PEAK	Pass
		2483.5	N/A	54	N/A	AVERAGE	Pass

GFSK LOW CHANNEL , PEAK

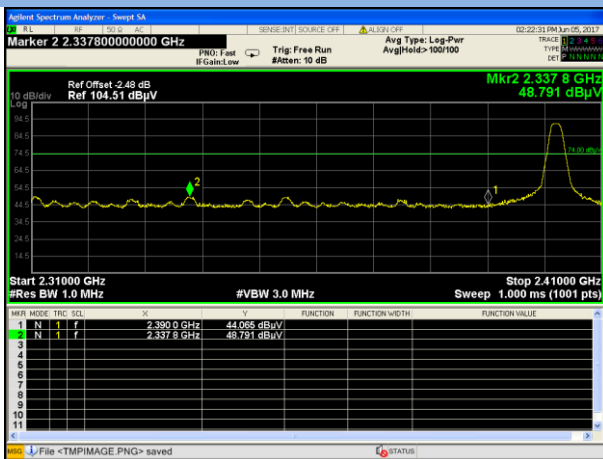

GFSK HIGH CHANNEL , PEAK

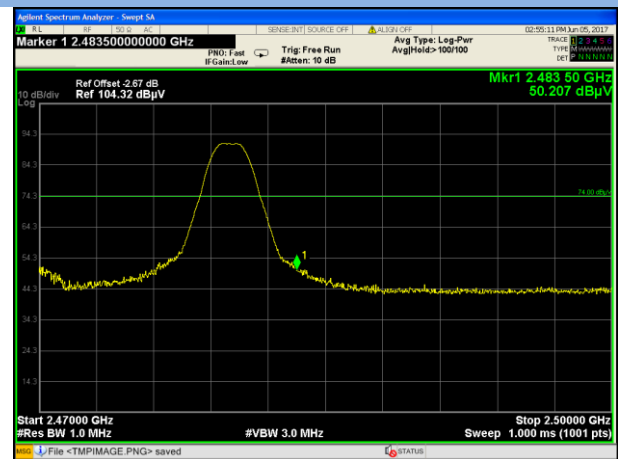



## Hopping Mode:

### GFSK LOW FREQUENCY BAND, PEAK

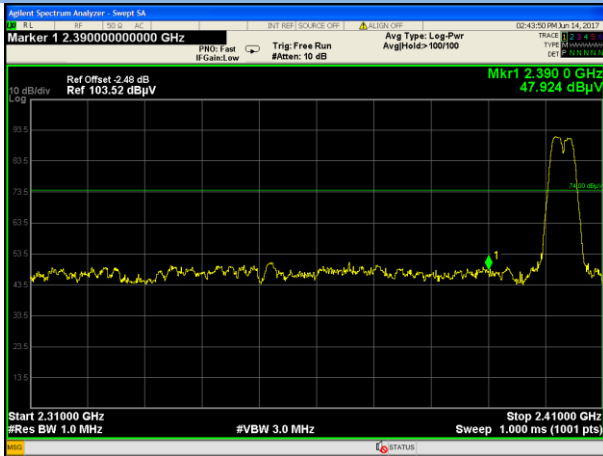

### GFSK HIGH FREQUENCY BAND, PEAK

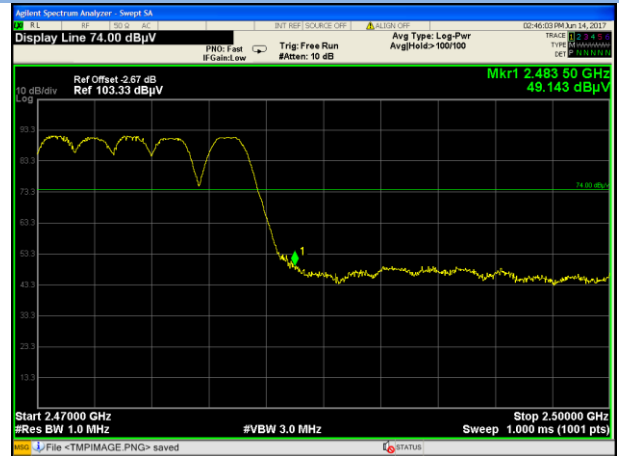

---

## **ANNEX B TEST SETUP PHOTOS**

Please refer the document "BL-SZ1750414-AR.PDF".

## **ANNEX C EUT EXTERNAL PHOTOS**

Please refer the document "BL-SZ1750414-AW.PDF".

## **ANNEX D EUT INTERNAL PHOTOS**

Please refer the document "BL-SZ1750414-AI.PDF".

--END OF REPORT--