



# FCC Part 15C Test Report

## FCC ID: 2ALKI-P20

Product Name:	Smart POS / Wireless POS
Trademark:	N/A
Model Name :	P20
Prepared For :	Wuhan Tianyu Information Industry Co., Ltd.
Address :	HUST Industry Park, East-Lake Development Zone, Wuhan 430223, Hubei, China
Prepared By :	Shenzhen BCTC Technology Co., Ltd.
Address :	No.101, Yousong Road, Longhua New District, Shenzhen, China
Test Date:	Jun. 10 – Jul. 01, 2017
Date of Report :	Jul. 01, 2017
Report No.:	BCTC-FY170603965-1E



### TEST RESULT CERTIFICATION

**Applicant's name**..... : Wuhan Tianyu Information Industry Co., Ltd.  
**Address**..... : HUST Industry Park, East-Lake Development Zone, Wuhan  
 430223, Hubei, China  
**Manufacture's Name**..... : Wuhan Tianyu Information Industry Co., Ltd.  
**Address**..... : HUST Industry Park, East-Lake Development Zone, Wuhan  
 430223, Hubei, China  
**Product description**  
**Product name**.....: Smart POS / Wireless POS  
**Trademark**.....: N/A  
**Model and/or type reference** : P20  
**Standards**..... : FCC Part15B  
 ANSI C63.4-2014

This device described above has been tested by BCTC, and the test results show that the equipment under test (EUT) is in compliance with the FCC requirements. And it is applicable only to the tested sample identified in the report.

This report shall not be reproduced except in full, without the written approval of BCTC, this document may be altered or revised by BCTC, personal only, and shall be noted in the revision of the document.

Testing Engineer : Eric Yang  
 Eric Yang

Reviewer Supervisor : Jade Yang  
 Jade Yang

Approved & Authorized Manager: Carson Zhang  



<b>Table of Contents</b>	<b>Page</b>
<b>1 . SUMMARY OF TEST RESULTS</b>	<b>4</b>
1.1 TEST FACILITY	4
1.2 MEASUREMENT UNCERTAINTY	4
<b>2 . GENERAL INFORMATION</b>	<b>5</b>
2.1 GENERAL DESCRIPTION OF EUT	5
2.2 DESCRIPTION OF TEST MODES	6
2.3 BLOCK DIGRAM SHOWING THE CONFIGURATION OF SYSTEM TESTED	7
2.4 DESCRIPTION OF SUPPORT UNITS(CONDUCTED MODE)	7
2.5 EQUIPMENTS LIST FOR ALL TEST ITEMS	8
<b>3 . EMC EMISSION TEST</b>	<b>9</b>
3.1 CONDUCTED EMISSION MEASUREMENT	9
3.1.1 POWER LINE CONDUCTED EMISSION LIMITS	9
3.1.2 TEST PROCEDURE	9
3.1.3 DEVIATION FROM TEST STANDARD	9
3.1.4 TEST SETUP	10
3.1.5 EUT OPERATING CONDITIONS	10
3.1.6 TEST RESULTS	10
3.2 RADIATED EMISSION MEASUREMENT	15
3.2.1 RADIATED EMISSION LIMITS	15
3.2.2 TEST PROCEDURE	15
3.2.3 DEVIATION FROM TEST STANDARD	16
3.2.4 TEST SETUP	16
3.2.5 EUT OPERATING CONDITIONS	17
3.2.6 TEST RESULTS (BETWEEN 9KHZ – 30 MHZ)	18
3.2.7 TEST RESULTS (BETWEEN 30MHZ – 1GHZ)	19
3.2.8 TEST RESULTS (BETWEEN 1GHZ– 15GHZ)	21
<b>4 . TEST SETUP PHOTO</b>	<b>23</b>
<b>5 . EUT PHOTO</b>	<b>25</b>



## 1. SUMMARY OF TEST RESULTS

Test procedures according to the technical standards:

FCC Part15			
Standard Section	Test Item	Judgment	Remark
Part 15.107	Conducted Emission	PASS	
Part 15.109	Radiated Spurious Emission	PASS	

### NOTE:

(1) "N/A" denotes test is not applicable in this Test Report

### 1.1 TEST FACILITY

Shenzhen BCTC Technology Co., Ltd.

Add. : No.101,Yousong Road,Longhua New District, Shenzhen,China

FCC Registered No.: 187086

### 1.2 MEASUREMENT UNCERTAINTY

The reported uncertainty of measurement  $y \pm U$ , where expanded uncertainty  $U$  is based on a standard uncertainty multiplied by a coverage factor of  $k=2$ , providing a level of confidence of approximately **95 %**.

No.	Item	Uncertainty
1	Conducted Emission Test	$\pm 1.38\text{dB}$
2	RF power,conducted	$\pm 0.16\text{dB}$
3	Spurious emissions,conducted	$\pm 0.21\text{dB}$
4	All emissions,radiated(<1G)	$\pm 4.68\text{dB}$
5	All emissions,radiated(>1G)	$\pm 4.89\text{dB}$
6	Temperature	$\pm 0.5^{\circ}\text{C}$
7	Humidity	$\pm 2\%$



## 2. GENERAL INFORMATION

### 2.1 GENERAL DESCRIPTION OF EUT

Equipment	Smart POS / Wireless POS
Trade Name	N/A
Model Name	P20
Model Difference	N/A
Product Description	The EUT is a Smart POS / Wireless POS Based on the application, features, or specification exhibited in User's Manual, the EUT is considered as an ITE/Computing Device. More details of EUT technical specification, please refer to the User's Manual.
Power	DC 3.7V from battery DC 5V from adapter
Adapter	Model:SAP050200CN-C I/P: AC 100-240V 50/60Hz O/P: DC 5V 2.0A
hardware version	--
Software version	--
Serial number	--
Connecting I/O Port(s)	Please refer to the User's Manual
Max Operation Frequency	2.7GHz

Note:

1. For a more detailed features description, please refer to the manufacturer's specifications or the User's Manual.



## 2.2 DESCRIPTION OF TEST MODES

To investigate the maximum EMI emission characteristics generated from EUT, the test system was pre-scanning tested based on the consideration of following EUT operation mode or test configuration mode which possibly have effect on EMI emission level. Each of these EUT operation mode(s) or test configuration mode(s) mentioned above was evaluated respectively.

Pretest Mode	Description
Mode 1	Data Transmission
Mode 2	Charging mode
<b>For Conducted &amp; Radiated Emission</b>	
Final Test Mode	Description
Mode 1	Data Transmission

### 2.3 BLOCK DIGRAM SHOWING THE CONFIGURATION OF SYSTEM TESTED

Conducted and Radiated Emission Test

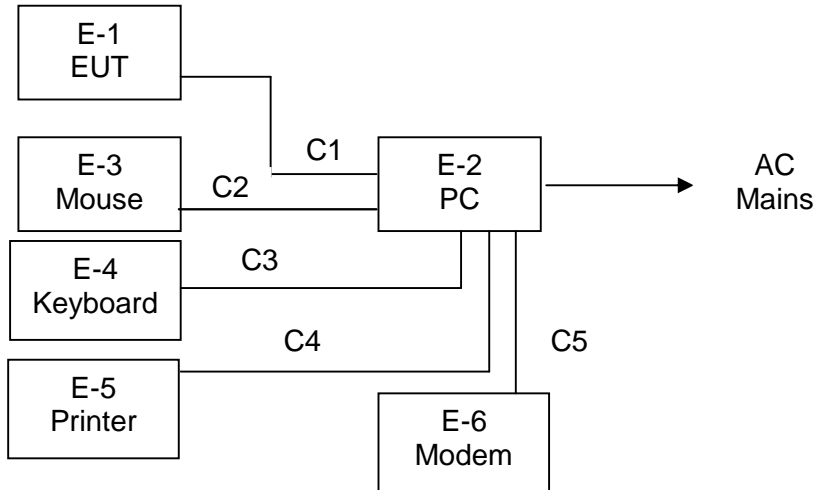

### 2.4 DESCRIPTION OF SUPPORT UNITS(CONDUCTED MODE)

The EUT has been tested as an independent unit together with other necessary accessories or support units. The following support units or accessories were used to form a representative test configuration during the tests.

Item	Equipment	Mfr/Brand	Model/Type No.	Series No.	Note
E-1	Smart POS / Wireless POS	N/A	P20	N/A	EUT
E-2	PC	BCTC	BC036	N/A	
E-3	Mouse	LJIAN	LM025C	N/A	
E-4	Keyboard	LJIAN	LK019D	N/A	
E-5	Printer	HP	CC418A	N/A	
E-6	Modem	SIHAI	MV2400	N/A	

Item	Shielded Type	Ferrite Core	Length	Note
C1	No	No	0.8m	USB Line
C2	No	No	1.2m	RJ45 Line
C3	No	No	0.8m	USB Cable
C4	No	No	1.2m	USB Cable
C5	No	No	1.2m	USB Cable

Note:

(1) For detachable type I/O cable should be specified the length in cm in 『Length』 column.



## 2.5 EQUIPMENTS LIST FOR ALL TEST ITEMS

### Radiation Test equipment

Item	Kind of Equipment	Manufacturer	Type No.	Serial No.	Last calibration	Calibrated until
1	Spectrum Analyzer	Agilent	E4407B	MY45109572	2016.08.27	2017.08.26
2	Test Receiver	R&S	ESPI	101396	2016.08.27	2017.08.26
3	Bilog Antenna	SCHWARZBECK	VULB9160	VULB9160-3369	2016.08.27	2017.08.26
4	50Ω Coaxial Switch	Anritsu	MP59B	6200264416	2016.08.27	2017.08.26
5	Spectrum Analyzer	Agilent	N9020A	MY5051041	2016.08.27	2017.08.26
6	Horn Antenna	SCHWARZBECK	9120D	9120D-1275	2016.08.29	2017.08.28
7	Horn Ant	Schwarzbeck	BBHA 9170	9170-181	2016.08.29	2017.08.28
8	Amplifier	SCHWARZBECK	BBV9718	9718-270	2016.08.29	2017.08.28
9	Amplifier	SCHWARZBECK	BBV9743	9743-119	2016.08.29	2017.08.28
10	Loop Antenna	ARA	PLP20MI-BT H0730/B	1029	2016.07.06	2017.07.05
11	Power Meter	R&S	NRVS	100696	2016.08.27	2017.08.26
12	Power Sensor	R&S	URV5-Z4	0395.1619.05	2016.08.27	2017.08.26
13	RF cables	R&S	N/A	N/A	2016.08.27	2017.08.26
14	966 chamber	ChengYu	966 Room	966	2016.08.27	2017.08.26

### Conduction Test equipment

Item	Kind of Equipment	Manufacturer	Type No.	Serial No.	Last calibration	Calibrated until
1	Test Receiver	R&S	ESCI	1166.5950K03-101165-ha	2016.08.27	2017.08.26
2	LISN	R&S	NSLK8126	8126466	2016.08.27	2017.08.26
3	LISN	R&S	NSLK8126	8126487	2016.08.27	2017.08.26
4	50Ω Coaxial Switch	Anritsu	MP59B	6200264417	2016.08.27	2017.08.26
5	RF cables	R&S	R204	R20X	2016.08.27	2017.08.26





### 3. EMC EMISSION TEST

#### 3.1 CONDUCTED EMISSION MEASUREMENT

##### 3.1.1 POWER LINE CONDUCTED EMISSION Limits (Frequency Range 150KHz-30MHz)

FREQUENCY (MHz)	Class A (dBuV)		Class B (dBuV)		Standard
	Quasi-peak	Average	Quasi-peak	Average	
0.15 -0.5	79.00	66.00	66 - 56 *	56 - 46 *	FCC
0.50 -5.0	73.00	60.00	56.00	46.00	FCC
5.0 -30.0	73.00	60.00	60.00	50.00	FCC

Note:

- (1) The tighter limit applies at the band edges.
- (2) The limit of " \* " marked band means the limitation decreases linearly with the logarithm of the frequency in the range.

The following table is the setting of the receiver

Receiver Parameters	Setting
Attenuation	10 dB
Start Frequency	0.15 MHz
Stop Frequency	30 MHz
IF Bandwidth	9 kHz

##### 3.1.2 TEST PROCEDURE

- a. The EUT was placed 0.8 meters from the horizontal ground plane with EUT being connected to the power mains through a line impedance stabilization network (LISN). All other support equipments powered from additional LISN(s). The LISN provide 50 Ohm/ 50uH of coupling impedance for the measuring instrument.
- b. Interconnecting cables that hang closer than 40 cm to the ground plane shall be folded back and forth in the center forming a bundle 30 to 40 cm long.
- c. I/O cables that are not connected to a peripheral shall be bundled in the center. The end of the cable may be terminated, if required, using the correct terminating impedance. The overall length shall not exceed 1 m.
- d. LISN at least 80 cm from nearest part of EUT chassis.
- e. For the actual test configuration, please refer to the related Item –EUT Test Photos.

##### 3.1.3 DEVIATION FROM TEST STANDARD

No deviation

### 3.1.4 TEST SETUP

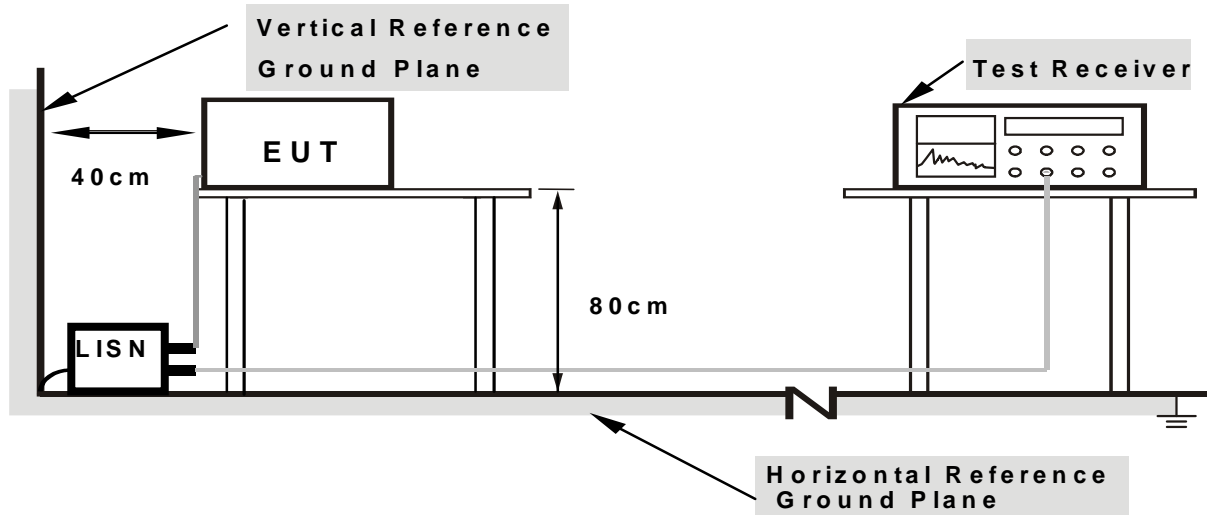

Note: 1.Support units were connected to second LISN.

2.Both of LISNs (AMN) are 80 cm from EUT and at least 80 cm from other units and other metal planes

### 3.1.5 EUT OPERATING CONDITIONS

The EUT was configured for testing in a typical fashion (as a customer would normally use it). The EUT has been programmed to continuously transmit during test. This operating condition was tested and used to collect the included data.

We pretest AC 120V and AC 240V, the worst voltage was AC 120V and the data recording in the report.

### 3.1.6 TEST RESULTS



Temperature :	25 °C	Relative Humidity :	54%
Pressure :	1010hPa	Phase :	L
Test Voltage :	DC 5V from PC input AC 120V/60Hz	Test Mode :	Mode 1

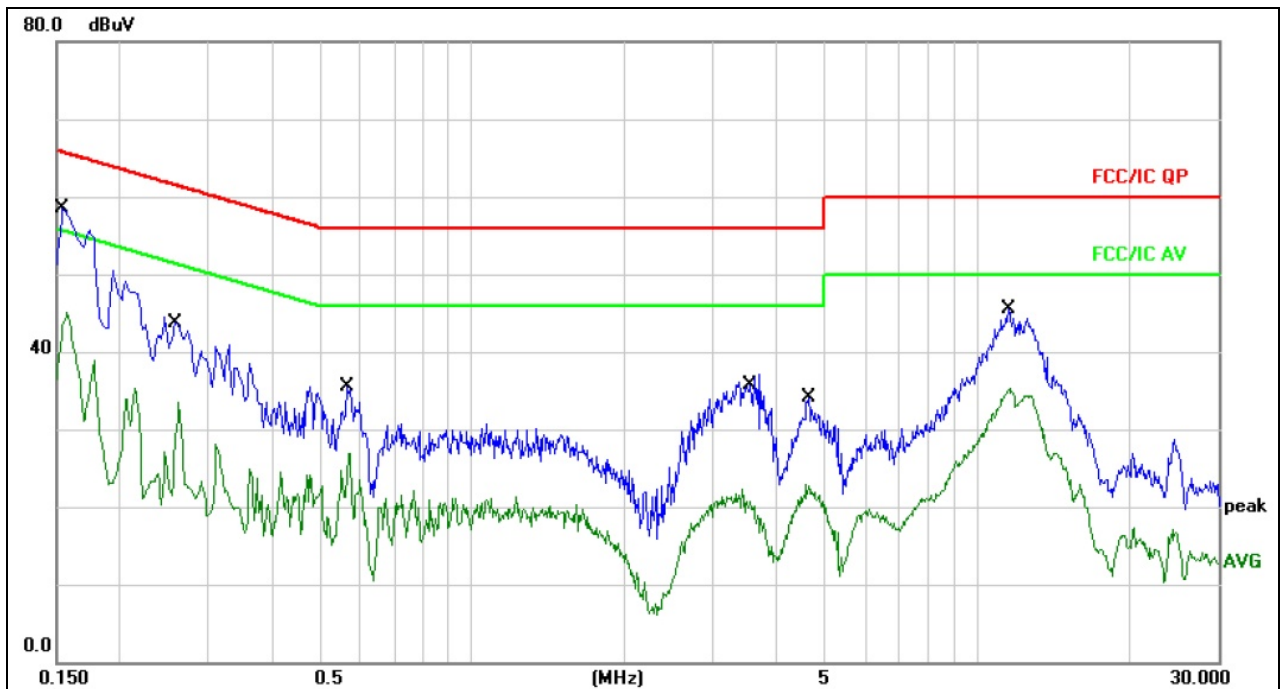

Remark:

1. All readings are Quasi-Peak and Average values.
2. Factor = Insertion Loss + Cable Loss.

No.	Mk.	Freq.	Reading Level	Correct Factor	Measurement	Limit	Over	Detector	Comment
		MHz	dBuV	dB	dBuV	dBuV	dB		
1	*	0.1539	48.40	10.05	58.45	65.78	-7.33	QP	
2		0.1539	34.95	10.05	45.00	55.78	-10.78	AVG	
3		0.2620	32.69	10.08	42.77	61.36	-18.59	QP	
4		0.2620	23.35	10.08	33.43	51.36	-17.93	AVG	
5		0.5660	25.44	10.12	35.56	56.00	-20.44	QP	
6		0.5660	16.75	10.12	26.87	46.00	-19.13	AVG	
7		3.5580	27.01	10.17	37.18	56.00	-18.82	QP	
8		3.5580	10.62	10.17	20.79	46.00	-25.21	AVG	
9		4.6460	23.92	10.15	34.07	56.00	-21.93	QP	
10		4.6460	12.57	10.15	22.72	46.00	-23.28	AVG	
11		11.5380	35.34	10.13	45.47	60.00	-14.53	QP	
12		11.5380	25.21	10.13	35.34	50.00	-14.66	AVG	



Temperature :	25 °C	Relative Humidity :	54%
Pressure :	1010hPa	Phase :	N
Test Voltage :	DC 5V from PC input AC 120V/60Hz	Test Mode :	Mode 1

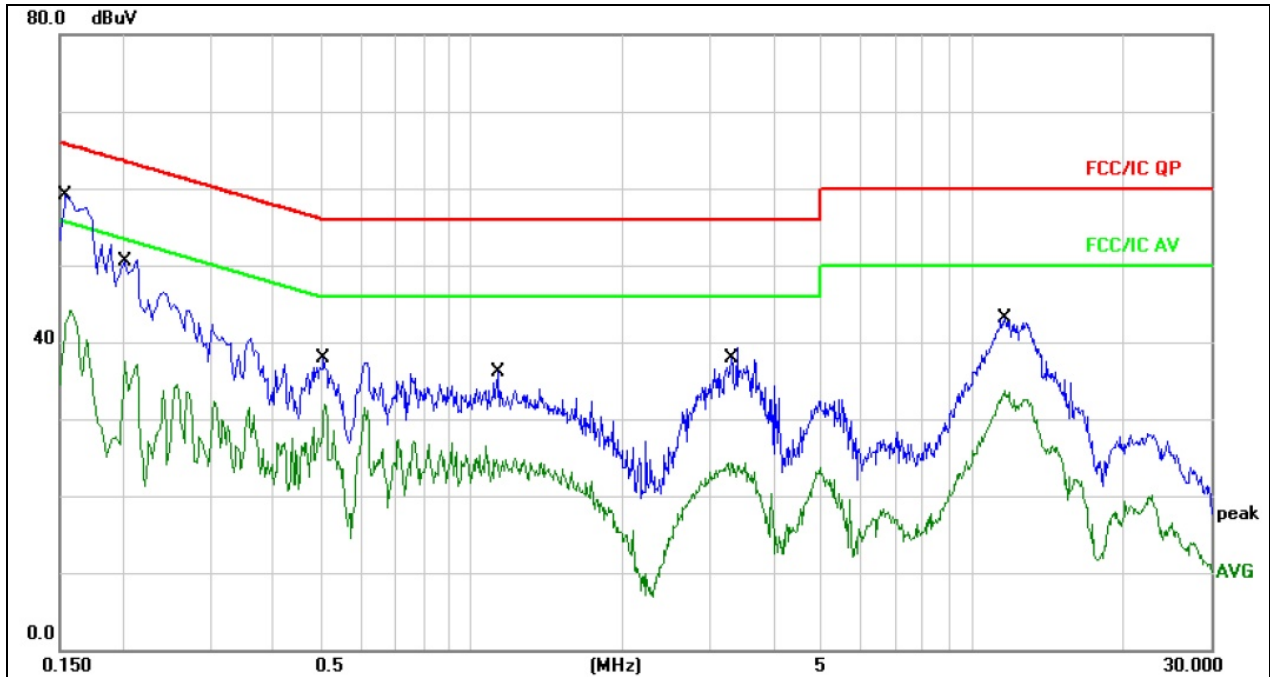

Remark:

1. All readings are Quasi-Peak and Average values.
2. Factor = Insertion Loss + Cable Loss.

No.	Mk.	Freq.	Reading Level	Correct Factor	Measurement	Limit	Over	Detector	Comment
		MHz	dBuV	dB	dBuV	dBuV	dB		
1	*	0.1539	49.06	10.05	59.11	65.78	-6.67	QP	
2		0.1539	34.09	10.05	44.14	55.78	-11.64	AVG	
3		0.2020	40.63	10.07	50.70	63.52	-12.82	QP	
4		0.2020	27.38	10.07	37.45	53.52	-16.07	AVG	
5		0.5060	27.83	10.12	37.95	56.00	-18.05	QP	
6		0.5060	21.69	10.12	31.81	46.00	-14.19	AVG	
7		1.1300	26.02	10.17	36.19	56.00	-19.81	QP	
8		1.1300	14.79	10.17	24.96	46.00	-21.04	AVG	
9		3.2740	29.17	10.18	39.35	56.00	-16.65	QP	
10		3.2740	14.22	10.18	24.40	46.00	-21.60	AVG	
11		11.6540	32.89	10.13	43.02	60.00	-16.98	QP	
12		11.6540	23.62	10.13	33.75	50.00	-16.25	AVG	



Temperature :	25 °C	Relative Humidity :	54%
Pressure :	1010hPa	Phase :	L
Test Voltage :	DC 5V from PC input AC 120V/60Hz	Test Mode :	Mode 2

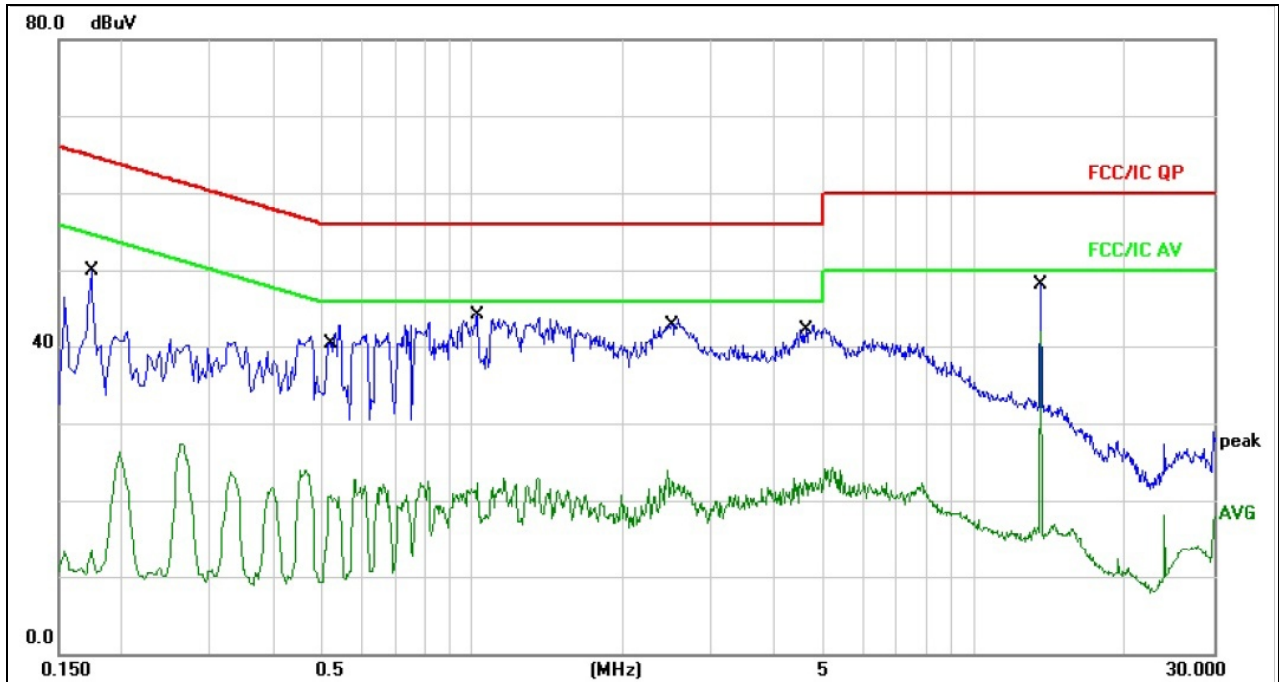

Remark:

1. All readings are Quasi-Peak and Average values.
2. Factor = Insertion Loss + Cable Loss.

No.	Mk.	Freq. MHz	Reading Level dBuV	Correct Factor dB	Measure- ment dBuV	Limit dBuV	Over dB	Detector	Comment
1		0.1740	39.86	10.06	49.92	64.76	-14.84	QP	
2		0.1740	5.92	10.06	15.98	54.76	-38.78	AVG	
3		0.5220	32.63	10.12	42.75	56.00	-13.25	QP	
4		0.5220	10.51	10.12	20.63	46.00	-25.37	AVG	
5		1.0260	33.96	10.17	44.13	56.00	-11.87	QP	
6		1.0260	12.10	10.17	22.27	46.00	-23.73	AVG	
7		2.5100	33.40	10.19	43.59	56.00	-12.41	QP	
8		2.5100	12.29	10.19	22.48	46.00	-23.52	AVG	
9		4.6100	32.46	10.15	42.61	56.00	-13.39	QP	
10		4.6100	12.60	10.15	22.75	46.00	-23.25	AVG	
11		13.5620	38.05	10.14	48.19	60.00	-11.81	QP	
12	*	13.5620	31.83	10.14	41.97	50.00	-8.03	AVG	



Temperature :	25 °C	Relative Humidity :	54%
Pressure :	1010hPa	Phase :	N
Test Voltage :	DC 5V from PC input AC 120V/60Hz	Test Mode :	Mode 2

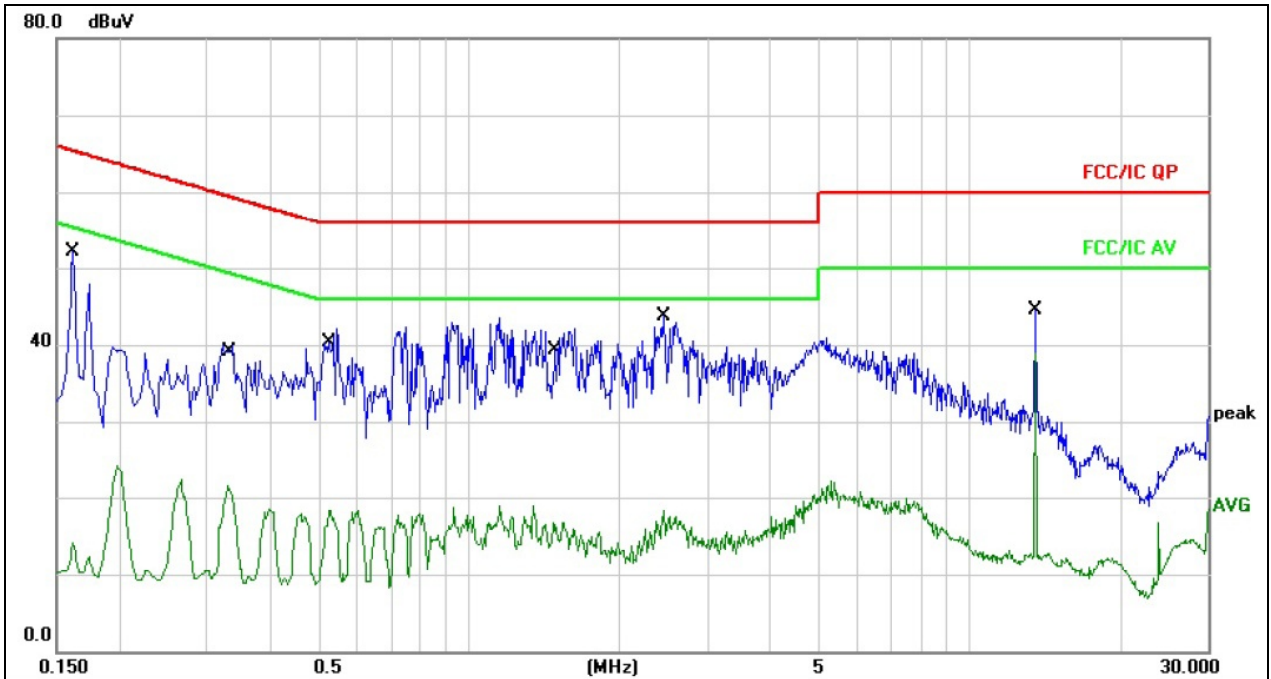

Remark:

1. All readings are Quasi-Peak and Average values.
2. Factor = Insertion Loss + Cable Loss.

No.	Mk.	Freq.	Reading Level	Correct Factor	Measurement	Limit	Over	Detector	Comment
		MHz	dBuV	dB	dBuV	dBuV	dB		
1		0.1620	41.97	10.05	52.02	65.36	-13.34	QP	
2		0.1620	4.12	10.05	14.17	55.36	-41.19	AVG	
3		0.3300	29.77	10.10	39.87	59.45	-19.58	QP	
4		0.3300	11.61	10.10	21.71	49.45	-27.74	AVG	
5		0.5260	31.97	10.12	42.09	56.00	-13.91	QP	
6		0.5260	8.25	10.12	18.37	46.00	-27.63	AVG	
7		1.4780	31.92	10.17	42.09	56.00	-13.91	QP	
8		1.4780	6.63	10.17	16.80	46.00	-29.20	AVG	
9		2.4500	33.48	10.18	43.66	56.00	-12.34	QP	
10		2.4500	8.16	10.18	18.34	46.00	-27.66	AVG	
11		13.5620	34.41	10.14	44.55	60.00	-15.45	QP	
12	*	13.5620	28.79	10.14	38.93	50.00	-11.07	AVG	



## 3.2 RADIATED EMISSION MEASUREMENT

### 3.2.1 RADIATED EMISSION LIMITS (Frequency Range 9kHz-1000MHz)

1. The field strength of any emissions within the band 13.553–13.567 MHz shall not exceed 15,848 microvolts/ meter at 30 meters
2. In case the emission fall within the restricted band specified on 15.205(a), then the 15.209(a) limit in the table below has to be followed.

Frequencies (MHz)	Field Strength (micorvolts/meter)	Measurement Distance (meters)
0.009~0.490	2400/F(KHz)	300
0.490~1.705	24000/F(KHz)	30
1.705~30.0	30	30
30~88	100	3
88~216	150	3
216~960	200	3
Above 960	500	3

Receiver Parameter	Setting
Attenuation	Auto
Start ~ Stop Frequency	9kHz~150kHz / RB 200Hz for QP
Start ~ Stop Frequency	150kHz~30MHz / RB 9kHz for QP
Start ~ Stop Frequency	30MHz~1000MHz / RB 120kHz for QP

### 3.2.2 TEST PROCEDURE

Below 1GHz test procedure as below:

- a. The EUT was placed on the top of a rotating table 0.8 meters above the ground at a 3 meter semi-anechoic chamber. The table was rotated 360 degrees to determine the position of the highest radiation.
- b. The EUT was set 3 meters away from the interference-receiving antenna, which was mounted on the top of a variable-height antenna tower.
- c. The antenna height is varied from one meter to four meters above the ground to determine the maximum value of the field strength. Both horizontal and vertical polarizations of the antenna are set to make the measurement.
- d. For each suspected emission, the EUT was arranged to its worst case and then the antenna was tuned to heights from 1 meter to 4 meters (for the test frequency of below 30MHz, the antenna was tuned to heights 1 meter) and the rotatable table was turned from 0 degrees to 360 degrees to find the maximum reading.
- e. The test-receiver system was set to Peak Detect Function and Specified Bandwidth with Maximum Hold Mode.
- f. If the emission level of the EUT in peak mode was 10dB lower than the limit specified, then testing could be stopped and the peak values of the EUT would be reported. Otherwise the emissions that did not have 10dB margin would be re-tested one by one using peak, quasi-peak or average method as specified and then reported in a data sheet.

### 3.2.3 DEVIATION FROM TEST STANDARD

No deviation

### 3.2.4 TEST SETUP

(A) Radiated Emission Test-Up Frequency Below 30MHz

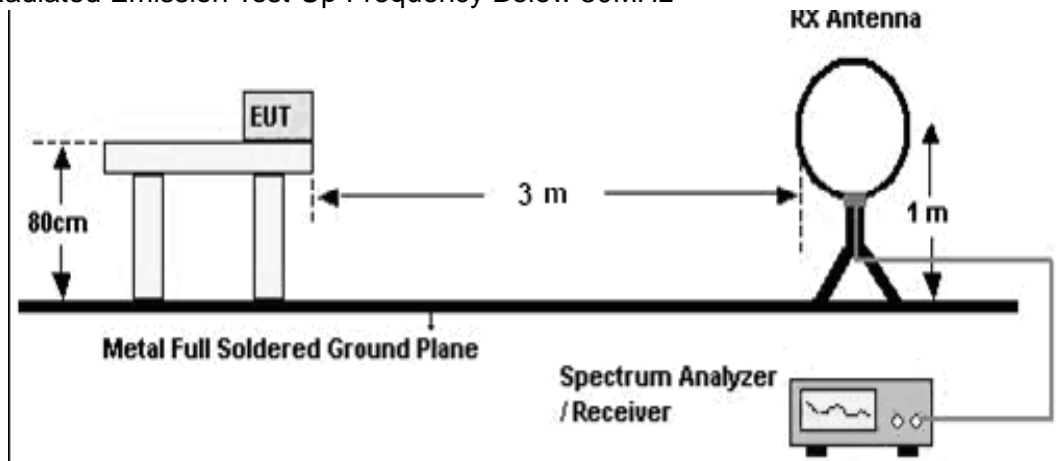



## (B) Radiated Emission Test-Up Frequency 30MHz~1GHz

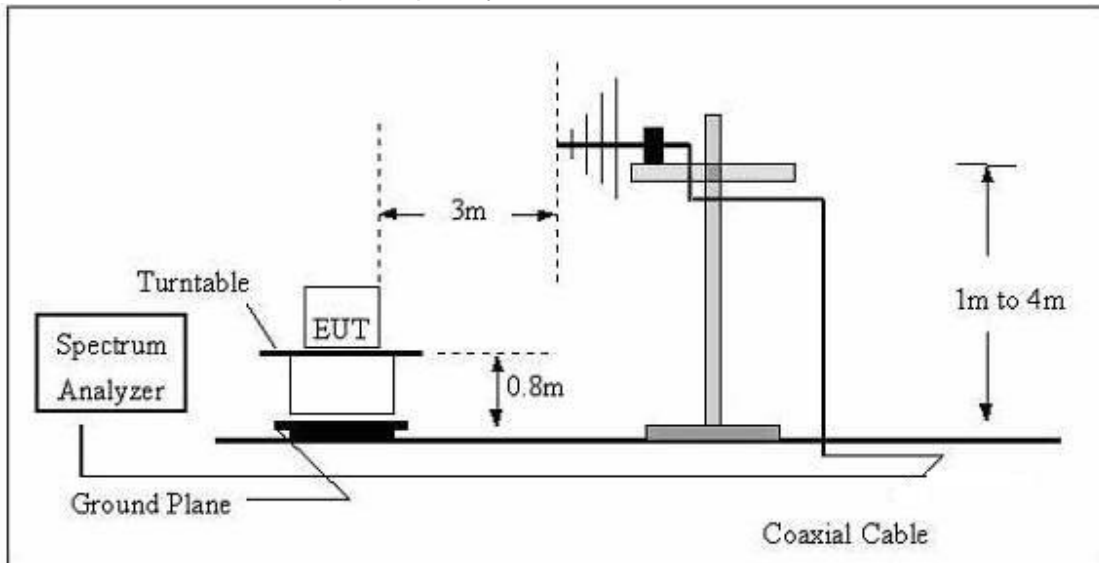

## (C) Radiated Emission Test-Up Frequency Above 1GHz

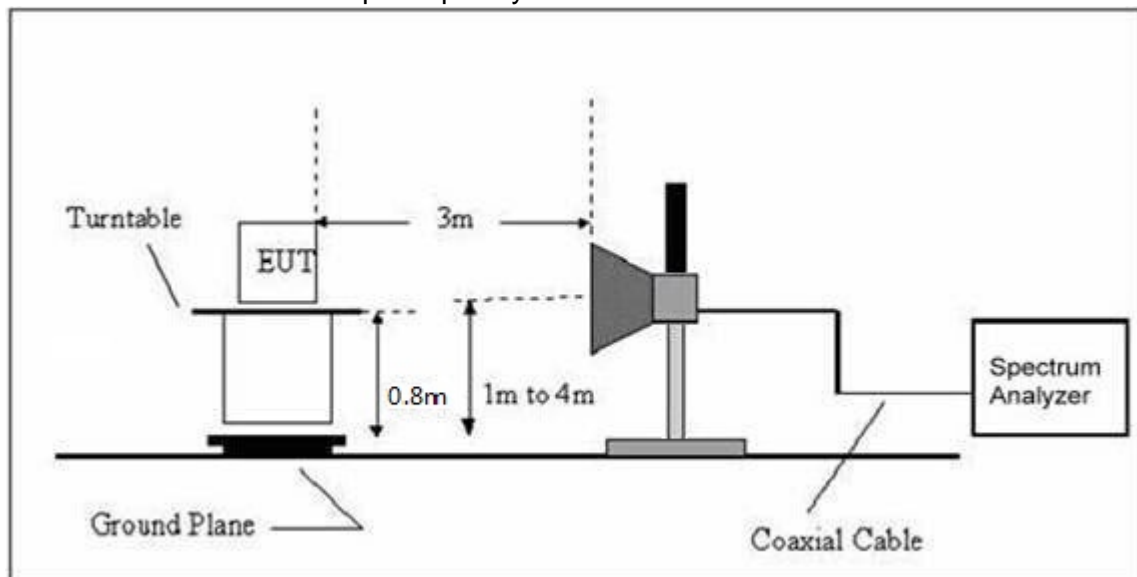

### 3.2.5 EUT OPERATING CONDITIONS

The EUT tested system was configured as the statements of 2.3 Unless otherwise a special operating condition is specified in the follows during the testing.

We pretest AC 120V and AC 240V, the worst voltage was AC 120V and the data recording in the report.

**3.2.6 TEST RESULTS (BETWEEN 9KHZ – 30 MHZ)**

Temperature:	20°C	Relative Humidity:	48%
Pressure:	1010 hPa	Test Voltage :	DC 5V from PC input AC 120V/60Hz
Test Mode :	Mode 1	Polarization :	--

Freq. (MHz)	Reading (dBuV/m)	Limit (dBuV/m)	Margin (dB)	State P/F
--	--	--	--	PASS
--	--	--	--	PASS

**NOTE:**

The amplitude of spurious emissions which are attenuated by more than 20dB below the permissible value has no need to be reported.

Distance extrapolation factor =  $40 \log(\text{specific distance}/\text{test distance})$ (dB);

Limit line = specific limits(dBuv) + distance extrapolation factor.



**3.2.7 TEST RESULTS (BETWEEN 30MHZ – 1GHZ)**

Temperature :	26°C	Relative Humidity :	54%
Pressure :	1010 hPa	Polarization :	Horizontal
Test Voltage :	DC 5V from PC input AC 120V/60Hz		
Test Mode :	Mode 1		

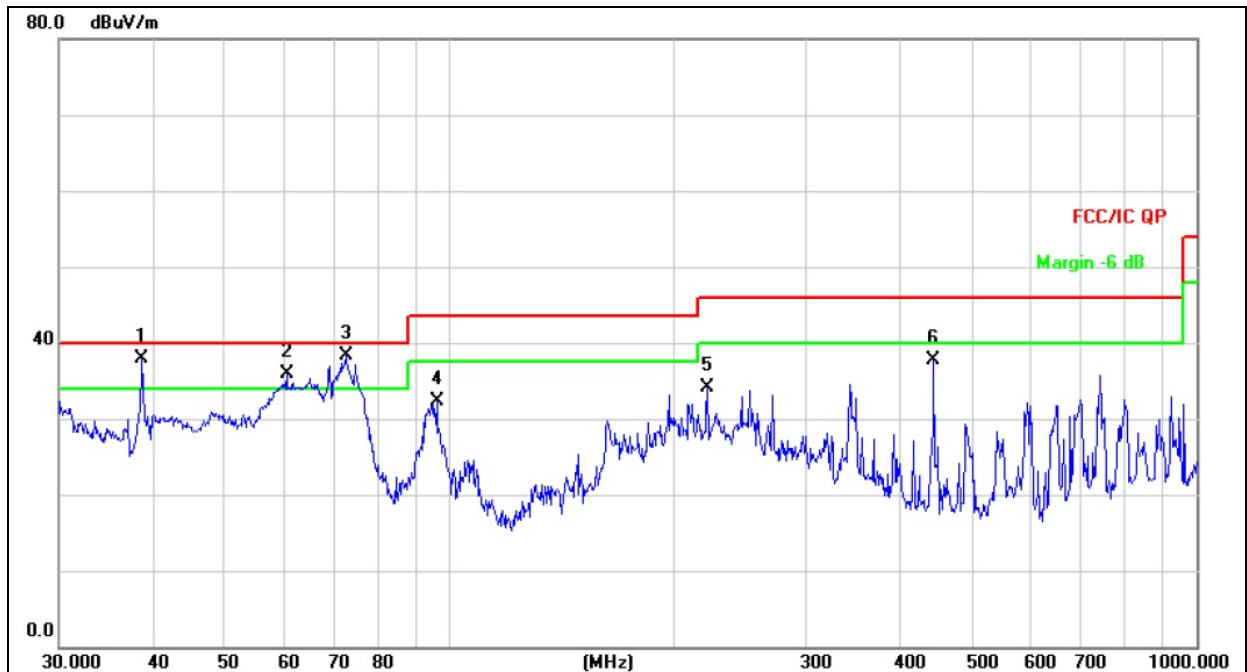

Remark:  
Factor = Antenna Factor + Cable Loss – Pre-amplifier.

No.	Mk.	Freq.	Reading Level	Correct Factor	Measurement	Limit	Over	Detector
		MHz	dBuV	dB/m	dBuV/m	dBuV/m	dB	
1	!	38.7518	46.67	-8.79	37.88	40.00	-2.12	QP
2	!	60.4919	47.61	-11.61	36.00	40.00	-4.00	QP
3	*	72.5916	53.86	-15.46	38.40	40.00	-1.60	QP
4		96.0986	49.29	-16.90	32.39	43.50	-11.11	QP
5		221.3921	49.60	-15.54	34.06	46.00	-11.94	QP
6		444.8514	46.82	-9.12	37.70	46.00	-8.30	QP



Temperature :	26°C	Relative Humidity :	54%
Pressure :	1010 hPa	Polarization :	Vertical
Test Voltage :	DC 5V from PC input AC 120V/60Hz		
Test Mode :	Mode 1		

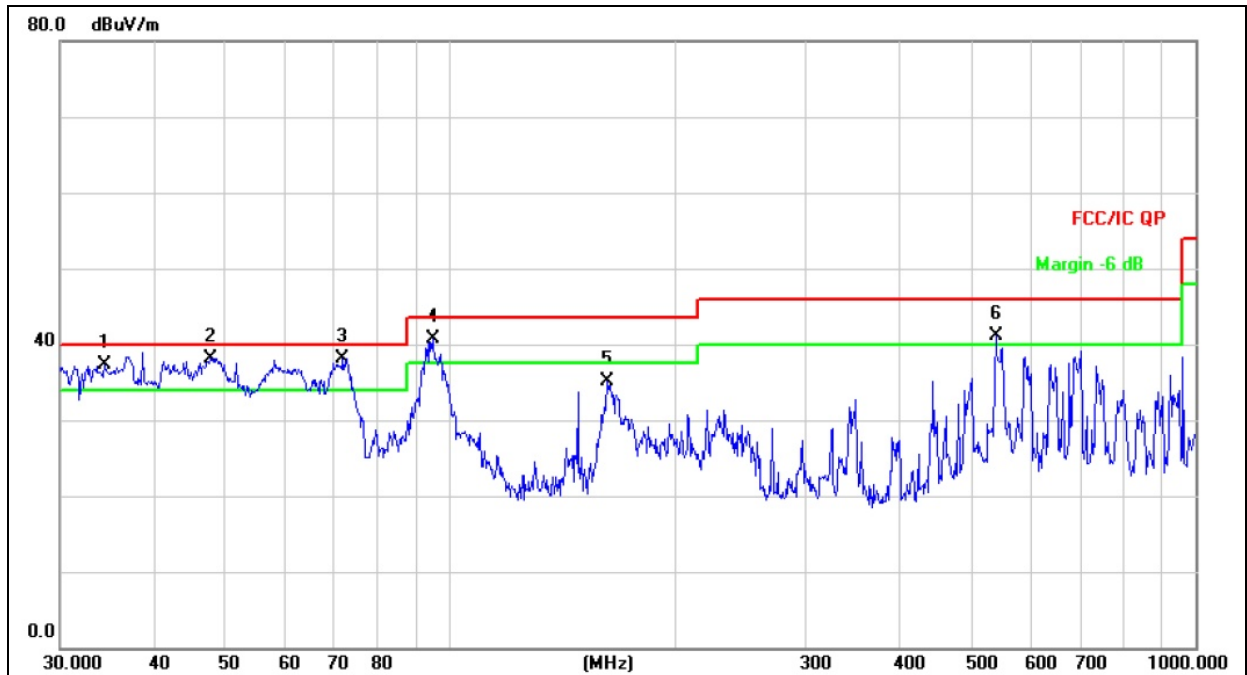

Remark:  
Factor = Antenna Factor + Cable Loss – Pre-amplifier.

No.	Mk.	Freq.	Reading Level	Correct Factor	Measurement	Limit	Over	Detector
		MHz	dBuV	dB/m	dBuV/m	dBuV/m	dB	
1	!	34.3964	45.76	-8.48	37.28	40.00	-2.72	QP
2	*	47.8260	48.08	-9.94	38.14	40.00	-1.86	QP
3	!	71.8320	53.33	-15.19	38.14	40.00	-1.86	QP
4	!	94.7601	57.71	-17.04	40.67	43.50	-2.83	QP
5		162.6106	48.04	-13.02	35.02	43.50	-8.48	QP
6	!	539.4775	48.60	-7.41	41.19	46.00	-4.81	QP



**3.2.8 TEST RESULTS (BETWEEN 1GHZ– 15GHZ)**

Temperature :	26°C	Relative Humidity :	54%
Pressure :	1010 hPa	Polarization :	Horizontal
Test Voltage :	DC 5V from PC input AC 120V/60Hz		
Test Mode :	Mode 1		

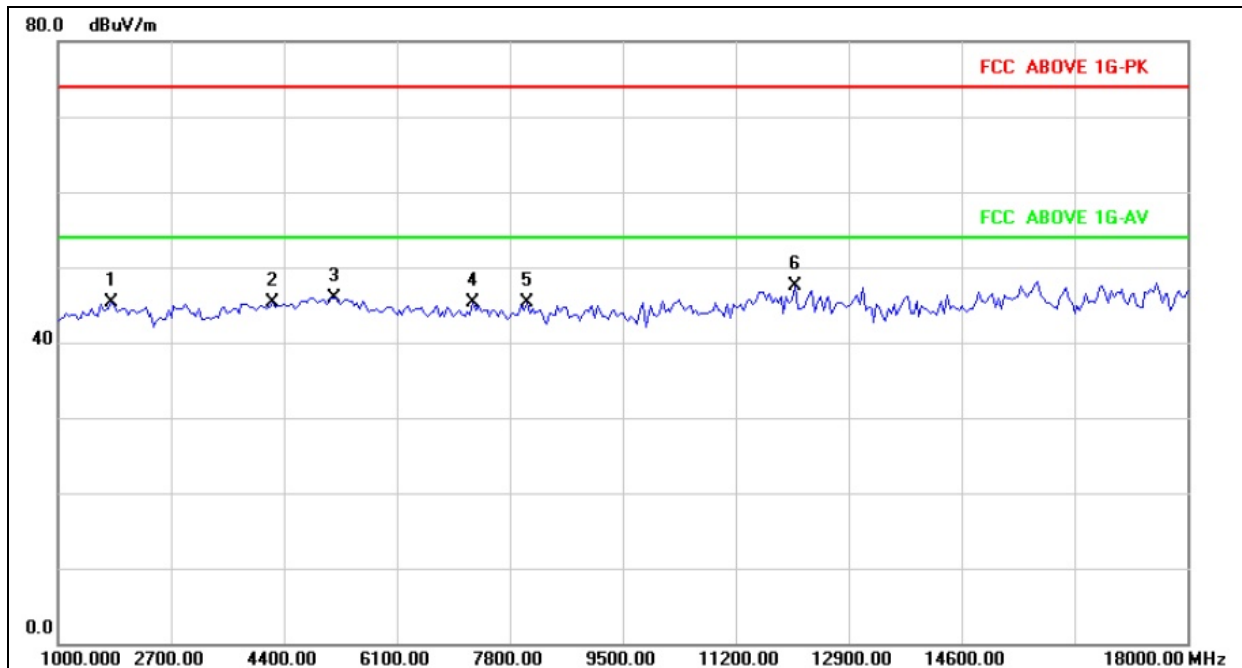

Remark:  
Factor = Antenna Factor + Cable Loss – Pre-amplifier.

No.	Mk.	Freq.	Reading Level	Correct Factor	Measurement	Limit	Over	
		MHz	dBuV	dB/m	dBuV/m	dBuV/m	dB	Detector
1		1807.500	37.65	7.61	45.26	74.00	-28.74	peak
2		4230.000	30.86	14.38	45.24	74.00	-28.76	peak
3		5165.000	29.87	16.01	45.88	74.00	-28.12	peak
4		7247.500	29.28	16.08	45.36	74.00	-28.64	peak
5		8055.000	28.00	17.27	45.27	74.00	-28.73	peak
6	*	12092.500	29.50	18.07	47.57	74.00	-26.43	peak



Temperature :	26°C	Relative Humidity :	54%
Pressure :	1010 hPa	Polarization :	Vertical
Test Voltage :	DC 5V from PC input AC 120V/60Hz		
Test Mode :	Mode 1		

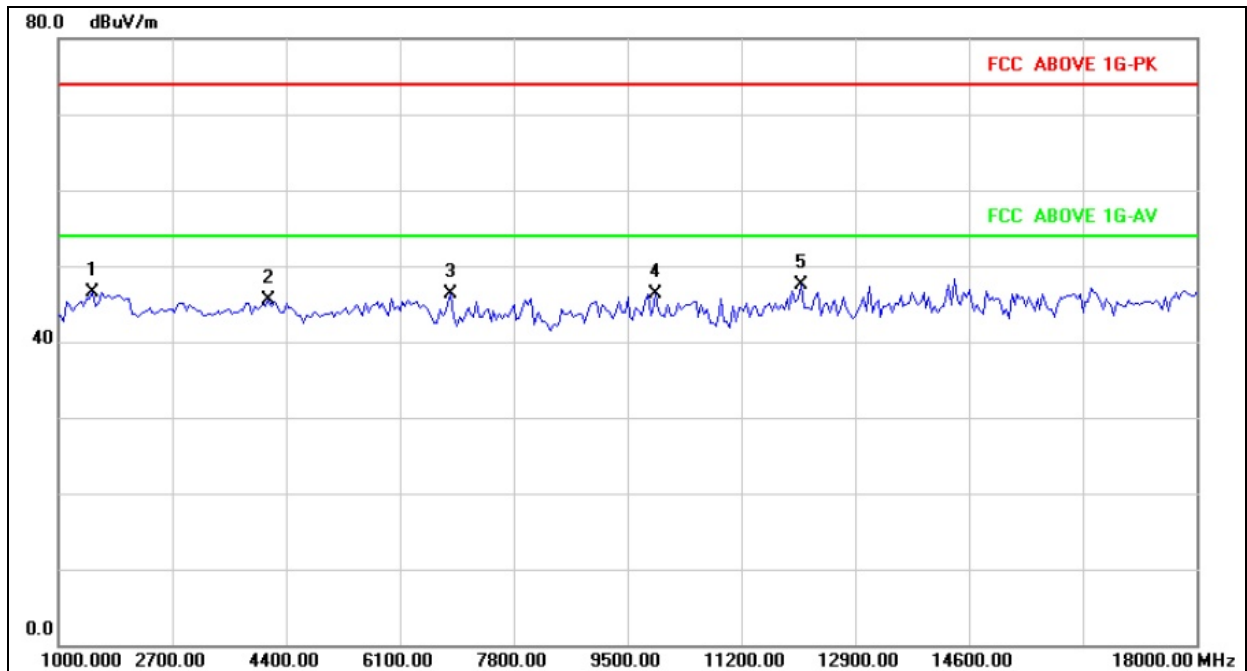

Remark:  
Factor = Antenna Factor + Cable Loss – Pre-amplifier.

No.	Mk.	Freq.	Reading Level	Correct Factor	Measurement	Limit	Over	Detector
		MHz	dBuV	dB/m	dBuV/m	dBuV/m	dB	
1		1510.000	39.02	7.55	46.57	74.00	-27.43	peak
2		4145.000	31.25	14.25	45.50	74.00	-28.50	peak
3		6865.000	30.25	15.98	46.23	74.00	-27.77	peak
4		9925.000	28.38	18.01	46.39	74.00	-27.61	peak
5		12092.500	29.50	18.07	47.57	74.00	-26.43	peak
6	*	14387.500	28.79	19.45	48.24	74.00	-25.76	peak

#### 4. TEST SETUP PHOTO

##### Radiated Measurement Photos

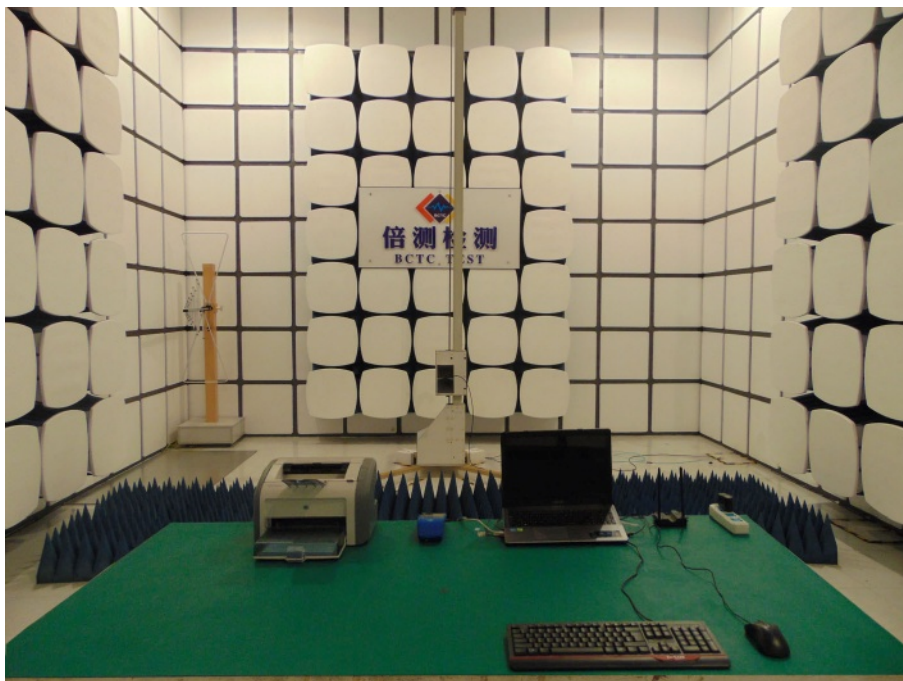
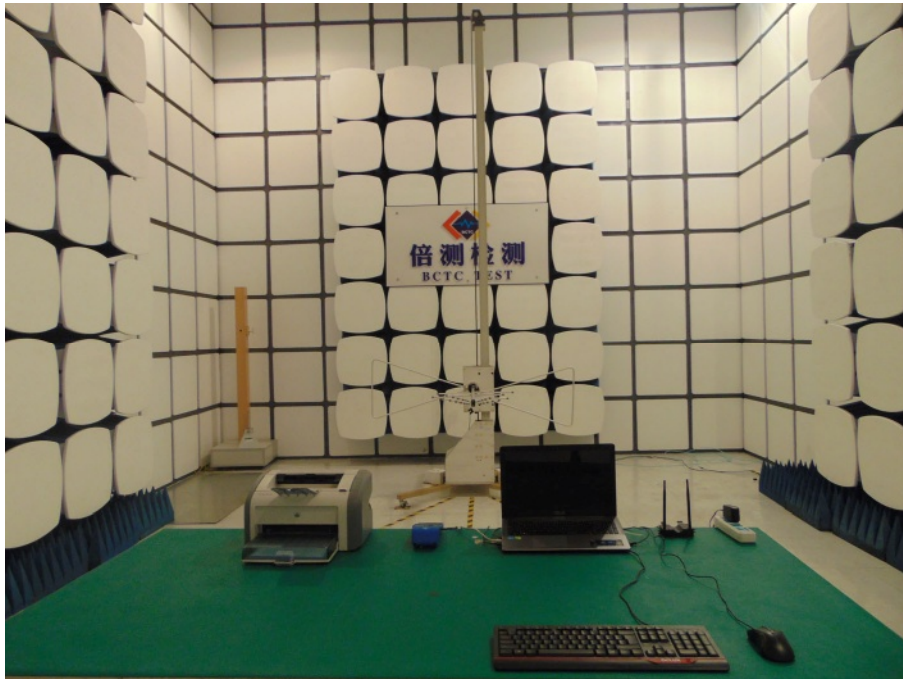



### Conducted Measurement Photos





## 5. EUT PHOTO







\*\*\*\*\* END OF REPORT \*\*\*\*\*