

RF TEST REPORT

FCC ID: 2ALKI-P10

Product Name : Smart POS Terminal
Brand Name : 
Test Model : P10
Applicant : Wuhan Tianyu Information Industry Co., Ltd.
Address : Huazhong University of Sci. & Tech., East Lake Dev. Zone, Wuhan
430223,Hubei,China
Manufacturer : Wuhan Tianyu Information Industry Co., Ltd.
Address : Huazhong University of Sci. & Tech., East Lake Dev. Zone, Wuhan
430223,Hubei,China
Date of Receipt : 2023.04.05
Date of Test : 2023.04.05~2023.04.28
Issued Date : 2023.04.28
Report Version : V1.0
Test Sample : Engineering Sample No.: AIT23040404-1
Standard(s) : FCC Part22 Rules;FCC Part24 Rules
FCC Part27 Rules;FCC Part 90 Rules;
ANSI C63.26:2015

Lab:Dongguan Yaxu (AiT) Technology Limited
Add:No.22,Jinqianling3rd Street,Jitigang,Huangjiang,Dongguan,
Guangdong,China
Tel.: +86-769-8202 0499 Fax.: +86-769-8202 0495

This device described above has been tested by Dongguan Yaxu (AiT) Technology Limited and the test results show that the equipment under test (EUT) is in compliance with the FCC requirements. And it is applicable only to the tested sample identified in the report.

Note: This report shall not be reproduced except in full, without the written approval of Dongguan Yaxu (AiT) Technology Limited, this document may be altered or revised by Dongguan Yaxu (AiT) Technology Limited, personal only, and shall be noted in the revision of the document. This test report must not be used by the client to claim product endorsement.

Reviewed by:



Simba huang



Seal Chen

Table of Contents

1. General Information.....	5
1.1 Applicant.....	5
1.2 Manufacturer	5
Basic Description of Equipment Under Test	5
1.3 Technical Specification	6
2. Summary of Test Results.....	8
2.1 TEST CONDITION : CONDUCTED TEST	8
2.2 TEST CONDITION : RADIATED TEST	8
3. General Test Frequency and Configuration	9
3.1 Test Modes	9
3.2 Test Frequency	9
3.3 Test Environment.....	12
3.4 Test Instruments	13
3.5 Measurement Uncertainty	14
3.6 Test Location	14
3.7 Deviation from Standards	14
3.8 Abnormalities from Standard Conditions	14
4. Test Setup and Conditions	15
4.1 Test Setup 1	15
4.2 Test Setup 2	15
4.3 Test Setup 3	16
Step 1: Pre-test	16
Step 2: Substitution method to verify the maximum ERP/EIRP	16
4.4 Test Conditions	17
5. Description of Tests	19
5.1 Effective (Isotropic) Radiated Power	19
5.2 Peak-Average Ratio	20



5.3 Occupied Bandwidth21

5.4 Band Edge Compliance.....22

5.5 Spurious and Harmonic Emissions at Antenna Terminal23

5.6 Field Strength of Spurious Radiation24

5.7 Frequency Stability / Temperature Variation34

Revision History

Revision	Issue Date	Revisions	Revised By
V1.0	2023.04.28	Initial Issue	Seal Chen

1. General Information

1.1 Applicant

Wuhan Tianyu Information Industry Co., Ltd.

Huazhong University of Sci. & Tech., East Lake Dev. Zone, Wuhan 430223,Hubei,China

1.2 Manufacturer

Wuhan Tianyu Information Industry Co., Ltd.

Huazhong University of Sci. & Tech., East Lake Dev. Zone, Wuhan 430223,Hubei,China

Basic Description of Equipment Under Test

Items	Description	
Equipment Name	Smart POS Terminal	
Trademark		
Test Model Number	P10	
Series Model	N/A	
Difference Description	N/A	
Power Supply	DC 5V 2A by Adapter	
Battery	DC 3.80V by Built-in Li-ion Battery	
Antenna Type:	FPC antenna	
Operating Temperature	-10~50°C	
Hardware Version	V1.00	
Software Version	V1.00	
EUT Stage	<input type="radio"/> Product Unit	<input checked="" type="radio"/> Final-Sample
Radio SystemType	LTE	
Operating Band	Band 5,Band 7,Band 19,Band 26,Band 40,Band 41	

1.3 Technical Specification

Characteristics	Description	
Radio System Type	LTE	
Supported Frequency Range	LTE BAND5	Transmission (TX): 824 to 849 MHz
		Receiving (RX): 869 to 894 MHz
	LTE BAND7	Transmission (TX): 2500to 2570MHz
		Receiving (RX): 2620to 2690 MHz
	LTE BAND19	Transmission (TX): 830to 845MHz
		Receiving (RX): 875to 890 MHz
	LTE BAND26A	Transmission (TX): 824 to 849 MHz
		Receiving (RX): 869 to 894 MHz
	LTE BAND26B	Transmission (TX): 814 to 824MHz
		Receiving (RX): 859 to 869MHz
	LTE BAND40	Transmission (TX): 2300to 2360MHz
		Receiving (RX): 2300to 2360MHz
LTE BAND41	Transmission (TX): 2535 to 2655MHz	
	Receiving (RX): 2535 to 2655MHz	
TX and RX Antenna Ports	TX & RX port:	1
	TX-only port:	0
	RX-only port:	1
Target TX Output Power	LTE BAND4:24.39dBm;	
Antenna Gain:	LTE BAND5:1.03dBi;LTE BAND7:-0.92dBi;LTE BAND19:-4.10dBi; LTE BAND26:-4.10dBi;LTE BAND40:-1.34dBi;LTE BAND41:-0.92dBi;	
Supported Channel Bandwidth	LTE BAND5	1.4 MHz, 3 MHz, 5 MHz, 10 MHz
	LTE BAND7	5 MHz, 10 MHz, 15 MHz, 20 MHz
	LTE BAND19	5 MHz, 10 MHz, 15 MHz
	LTE BAND26	1.4 MHz, 3 MHz, 5 MHz, 10 MHz, 15 MHz
	LTE BAND40	5 MHz, 10 MHz
	LTE BAND41	5 MHz, 10 MHz, 15 MHz, 20 MHz
Designation of Emissions (Note: the necessary bandwidth of which is the worst value from the measured occupied bandwidths for each type of channel bandwidth configuration.)	LTE BAND5:	1M11G7D (1.4 MHz QPSK modulation), 1M11W7D (1.4 MHz 16QAM modulation) 2M69G7D (3 MHz QPSK modulation), 2M69W7D (3 MHz 16QAM modulation) 4M48G7D (5 MHz QPSK modulation) 4M48W7D (5 MHz 16QAM modulation) 8M96G7D (10 MHz QPSK modulation) 8M97W7D (10 MHz 16QAM modulation)
	LTE BAND7:	4M48G7D (5 MHz QPSK modulation) 4M48W7D (5 MHz 16QAM modulation) 8M96G7D (10 MHz QPSK modulation) 8M97W7D (10 MHz 16QAM modulation)

Characteristics	Description	
		13M5G7D (15 MHz QPSK modulation) 13M5W7D (15 MHz 16QAM modulation) 17M9G7D (20 MHz QPSK modulation) 18M0W7D (20 MHz 16QAM modulation)
	LTE BAND19:	4M48G7D (5 MHz QPSK modulation) 4M48W7D (5 MHz 16QAM modulation) 8M96G7D (10 MHz QPSK modulation) 8M97W7D (10 MHz 16QAM modulation) 13M5G7D (15 MHz QPSK modulation) 13M5W7D (15 MHz 16QAM modulation)
	LTE BAND26:	1M11G7D (1.4 MHz QPSK modulation), 1M11W7D (1.4 MHz 16QAM modulation) 2M69G7D (3 MHz QPSK modulation), 2M69W7D (3 MHz 16QAM modulation) 4M48G7D (5 MHz QPSK modulation) 4M48W7D (5 MHz 16QAM modulation) 8M96G7D (10 MHz QPSK modulation) 8M97W7D (10 MHz 16QAM modulation) 13M5G7D (15 MHz QPSK modulation) 13M5W7D (15 MHz 16QAM modulation)
	LTE BAND40:	4M48G7D (5 MHz QPSK modulation) 4M48W7D (5 MHz 16QAM modulation) 8M96G7D (10 MHz QPSK modulation) 8M97W7D (10 MHz 16QAM modulation)
	LTE BAND41:	4M48G7D (5 MHz QPSK modulation) 4M48W7D (5 MHz 16QAM modulation) 8M96G7D (10 MHz QPSK modulation) 8M97W7D (10 MHz 16QAM modulation) 13M5G7D (15 MHz QPSK modulation) 13M5W7D (15 MHz 16QAM modulation) 17M9G7D (20 MHz QPSK modulation) 18M0W7D (20 MHz 16QAM modulation)

2. Summary of Test Results

2.1 TEST CONDITION : CONDUCTED TEST

Item	Test Description	FCC Rules	Result
1	Occupied Bandwidth	§2.1049	Pass
2	Band Edge / Spurious and Harmonic Emissions at Antenna Terminal	§2.1051, §24.238(a) , §27.53(h) §27.53(m) (4), §27.53(g) , §90.691 §22.917(a)	Pass
3	Conducted Output Power	§2.1046, §90.635	Pass
4	Frequency stability / variation of ambient temperature	§2.1055, §24.235, §27.54 §90.213, §22.355	Pass
5	Peak- to- Average Ratio	§24.232(d), §27.50(d)(5)	Pass

Note:

*Since it was not possible to set the resolution bandwidth to 6.25 kHz with the available equipment, a bandwidth of 10kHz was used instead to show compliance.

2.2 TEST CONDITION : RADIATED TEST

Item	Test Description	FCC Rules	Result
1	Effective Radiated Power Equivalent Isotropic Radiated Power	§24.232(c), §27.50(d)(4), §27.50(h)(2) §27.50(c)(10), §22.913(a)(5)	Pass
2	Radiated Spurious and Harmonic Emissions	§2.1053, §24.238(a) , §27.53(h) §27.53(m)(4) , §27.53(g) , §90.691 §22.917(a)	Pass

3. General Test Frequency and Configuration

3.1 Test Modes

Test Mode	Test Modes Description
LTE/TM1	LTE system, QPSK modulation
LTE/TM2	LTE system, 16QAM modulation

3.2 Test Frequency

LTE Band 5 Channel and Frequency List				
BW [MHz]	Channel/Frequency (MHz)	Lowest	Middle	Highest
10	Channel	20450	20525	20600
	Frequency	829	836.5	844
5	Channel	20425	20525	20625
	Frequency	826.5	836.5	846.5
3	Channel	20415	20525	20635
	Frequency	825.5	836.5	847.5
1.4	Channel	20407	20525	20643
	Frequency	824.7	836.5	848.3

LTE Band 7 Channel and Frequency List				
BW [MHz]	Channel/Frequency (MHz)	Lowest	Middle	Highest
20	Channel	20850	21100	21350
	Frequency	2510	2535	2560
15	Channel	20825	21100	21375
	Frequency	2507.5	2535	2562.5
10	Channel	20800	21100	21400
	Frequency	2505	2535	2565
5	Channel	20775	21100	21425
	Frequency	2502.5	2535	2567.5

LTE Band 19 Channel and Frequency List				
BW [MHz]	Channel/Frequency (MHz)	Lowest	Middle	Highest
15	Channel	24075	-	--
	Frequency	837.5		
10	Channel	24050	24075	24100
	Frequency	835	837.5	840
5	Channel	24025	24075	24125
	Frequency	832.5	837.5	842.5

LTE Band 26A Channel and Frequency List				
BW [MHz]	Channel/Frequency (MHz)	Lowest	Middle	Highest
15	Channel	26865	26915	26965
	Frequency	831.5	836.5	841.5
10	Channel	26840	26915	26990
	Frequency	829	836.5	844
5	Channel	26815	26915	27015
	Frequency	826.5	836.5	846.5
3	Channel	26805	26915	27025
	Frequency	825.5	836.5	847.5
1.4	Channel	26797	26915	27033
	Frequency	824.7	836.5	848.3

LTE Band 26B Channel and Frequency List				
BW [MHz]	Channel/Frequency (MHz)	Lowest	Middle	Highest
15	Channel	26765	--	--
	Frequency	821.5	--	--
10	Channel	--	26740	--
	Frequency	--	819.0	--
5	Channel	26715	26740	26765
	Frequency	816.5	819.0	821.5
3	Channel	26705	26740	26775
	Frequency	815.5	819.0	822.5
1.4	Channel	26697	26740	26783
	Frequency	814.7	819.0	823.3



LTE Band 40 Channel and Frequency List				
BW [MHz]	Channel/Frequency (MHz)	Lowest	Middle	Highest
10	Channel	--	38750	--
	Frequency	--	2310.0	--
5	Channel	38675	38750	39225
	Frequency	2302.5	2310.0	2357.5

Test Mode	TX / RX	RF Channel		
		Low (B)	Middle (M)	High (T)
LTE Band 41	TX(5M)	Channel 40065	Channel40640	Channel 41215
		2537.5 MHz	2595 MHz	2652.5 MHz
	TX(10M)	Channel 40090	Channel40640	Channel 41190
		2540 MHz	2595 MHz	2650 MHz
	TX(15M)	Channel 40115	Channel40640	Channel 41165
		2542.5 MHz	2595 MHz	2647.5 MHz
	TX(20M)	Channel 40140	Channel40640	Channel 41140
		2545 MHz	2595 MHz	2645 MHz
	RX(5M)	Channel 40065	Channel40640	Channel 41215
		2537.5 MHz	2595 MHz	2652.5 MHz
	RX (10M)	Channel 40090	Channel40640	Channel 41190
		2540 MHz	2595 MHz	2650 MHz
	RX(15M)	Channel 40115	Channel40640	Channel 41165
		2542.5 MHz	2595 MHz	2647.5 MHz
	RX (20M)	Channel 40140	Channel40640	Channel 41140
		2545 MHz	2595 MHz	2645 MHz
		2115 MHz	2145MHz	2195 MHz
	RX(15M)	Channel 66511	Channel 66786	Channel 67261
2117.5 MHz		2145MHz	2192.5 MHz	
RX (20M)	Channel 66536	Channel 66786	Channel 67236	
	2120 MHz	2145MHz	2190 MHz	

3.3 Test Environment

Applicable to	Environmental conditions	Input Power	Tested by
Transmitter Conducted Power Output	24.5°C, 52 % RH	120Vac, 60Hz	Simba Huang
Peak-Average Ratio	24.5°C, 52 % RH	120Vac, 60Hz	Simba Huang
Modulation Characteristics	24.5°C, 52 % RH	120Vac, 60Hz	Simba Huang
Bandwidth	24.5°C, 52 % RH	120Vac, 60Hz	Simba Huang
Emission Mask	24.5°C, 52 % RH	120Vac, 60Hz	Simba Huang
Spurious Emission at Antenna Terminals	24.5°C, 53 % RH	120Vac, 60Hz	Simba Huang
Field Strength of Spurious Radiation	24.4°C, 53 % RH	120Vac, 60Hz	Simba Huang
Frequency Stability	24.5°C, 52 % RH	120Vac, 60Hz	Simba Huang

The applicant declare the operating environment of EUT as below:

Normal conditions: 3.8V DC, 15°C ~35°C

Extreme conditions: 3.42V DC~4.18V DC, -10°C ~50°C

VL= lower extreme test voltage, VN= nominal voltage, VH= upper extreme test voltage

TL= lower extreme test temperature, TN= normal temperature, TH= upper extreme test temperature

3.4 Test Instruments

No	Test Equipment	Manufacturer	Model No	Serial No	Cal. Date	Cal. Due Date
1	Spectrum Analyzer	R&S	FSV40	101470	2022.09.02	2023.09.01
2	EMI Measuring Receiver	R&S	ESR	101660	2022.09.02	2023.09.01
3	Low Noise Pre Amplifier	HP	HP8447E	1937A01855	2022.09.02	2023.09.01
4	Low Noise Pre Amplifier	Tsj	MLA-0120-A02-34	2648A04738	2022.09.02	2023.09.01
5	Passive Loop	ETS	6512	00165355	2020.09.05	2022.09.04
6	TRILOG Super Broadband test Antenna	SCHWARZBEC K	VULB9160	9160-3206	2021.08.29	2024.08.28
7	Broadband Horn Antenna	SCHWARZBEC K	BBHA9120D	452	2021.08.29	2024.08.28
8	SHF-EHF Horn Antenna 15-40GHz	SCHWARZBEC K	BBHA9170	BBHA9170367d	2020.11.24	2023.11.23
9	EMI Test Receiver	R&S	ESCI	100124	2022.09.02	2023.09.01
10	LISN	Kyoritsu	KNW-242	8-837-4	2022.09.02	2023.09.01
11	LISN	R&S	ESH3-Z2	0357.8810.54-101161-S2	2022.09.02	2023.09.01
12	Pro.Temp&Humi.chamber	MENTEK	MHP-150-1C	MAA08112501	2022.09.02	2023.09.01
13	RF Automatic Test system	MW	MW100-RFCB	21033016	2022.09.02	2023.09.01
14	Signal Generator	Agilent	N5182A	MY50143009	2022.09.02	2023.09.01
15	Wideband Radio communication tester	R&S	CMW500	1201.0002K50	2022.09.02	2023.09.01
16	RF Automatic Test system	MW	MW100-RFCB	21033016	2022.09.02	2023.09.01
17	DC power supply	ZHAOXIN	RXN-305D-2	28070002559	N/A	N/A
18	RE Software	EZ	EZ-EMC_RE	Ver.AIT-03A	N/A	N/A
19	CE Software	EZ	EZ-EMC_CE	Ver.AIT-03A	N/A	N/A
20	RF Software	MW	MTS 8310	2.0.0.0	N/A	N/A
21	temporary antenna connector(Note)	NTS	R001	N/A	N/A	N/A
22	Spectrum Analyzer	Agilent	N9020A	MT21033052	2022.09.02	2023.09.01

Note: The temporary antenna connector is soldered on the PCB board in order to perform conducted tests and this temporary antenna connector is listed in the equipment list.

3.5 Measurement Uncertainty

Where relevant, the following measurement uncertainty levels have been estimated for tests performed on the EUT.

This uncertainty represents an expanded uncertainty expressed at approximately the 95% confidence level using a coverage factor of k=2.

Uncertainty	
Parameter	Uncertainty
Occupied Channel Bandwidth	±142.08KHz
RF power conducted	±0.74dB
Band Edge Compliance	±1.24dB
Frequency stability	±0.12 ppm
Spurious emissions, radiated (0.009MHz~30MHz)	3.10dB
Spurious emissions, radiated (30MHz~1GHz)	3.75dB
Spurious emissions, radiated (1GHz~18GHz)	3.88dB
Spurious emissions, radiated (18GHz ~ 40GHz)	3.88dB
Humidity	±4.0%
Temperature	±0.5°C
Time	±1.20%

3.6 Test Location

Company:	Dongguan Yaxu (AiT) Technology Limited
Address:	No.22, Jinqianling 3rd Street, Jitigang, Huangjiang, Dongguan, Guangdong, China
CNAS Registration Number:	CNAS L14158
A2LA Registration Number:	6317.01
FCC Accredited Lab. Designation Number:	CN1313
FCC Test Firm Registration Number:	703111

3.7 Deviation from Standards

None

3.8 Abnormalities from Standard Conditions

None

4. Test Setup and Conditions

4.1 Test Setup 1

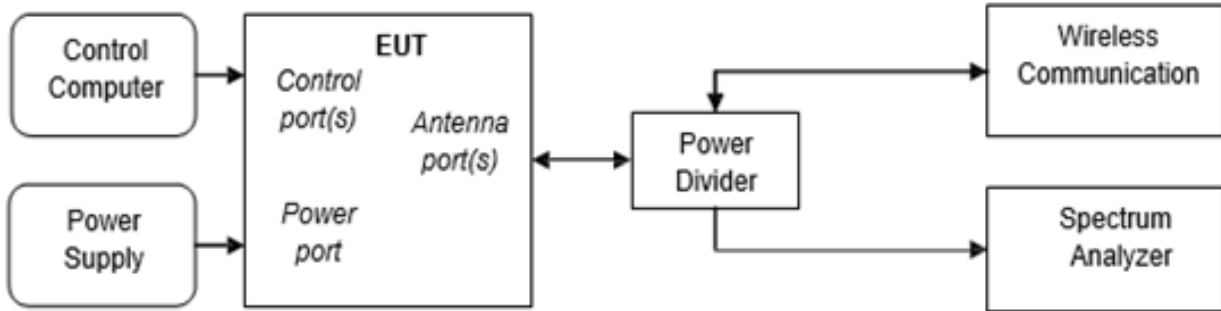

4.2 Test Setup 2

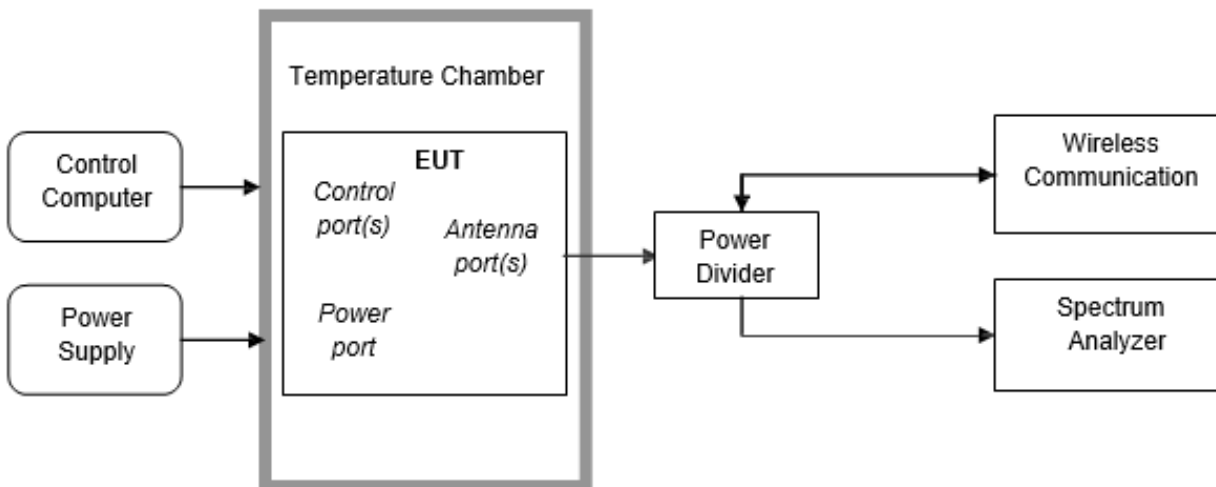

4.3 Test Setup 3

NOTE: Effective radiated power (ERP) and Equivalent Isotropic Radiated Power (EIRP) refers to the radiation power output of the EUT, assuming all emissions are radiated from half-wave dipole antennas.

Step 1: Pre-test

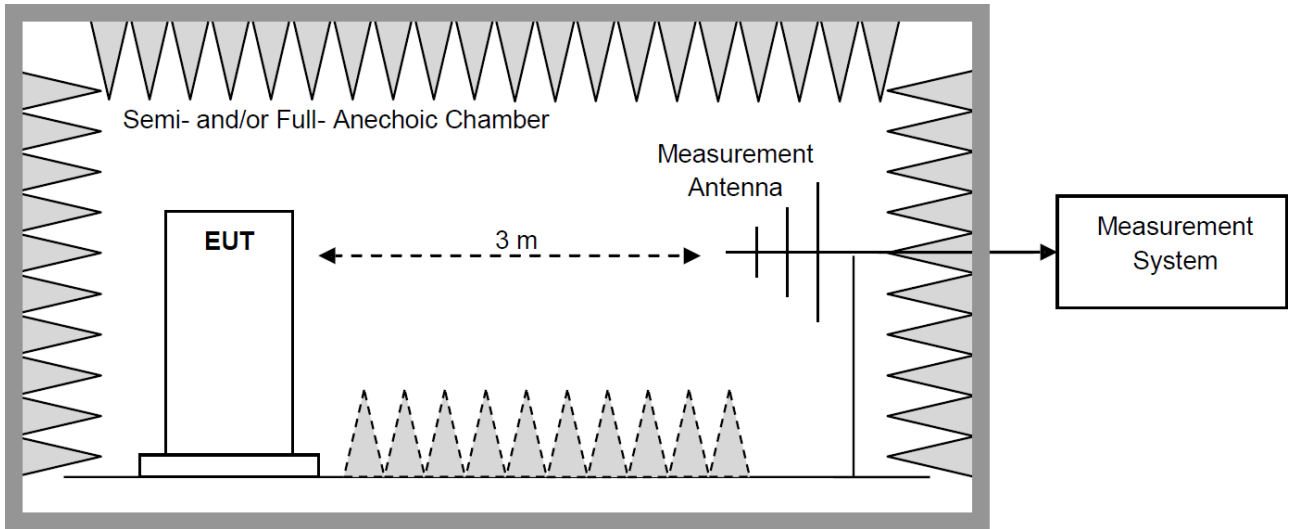

Step 2: Substitution method to verify the maximum ERP/EIRP

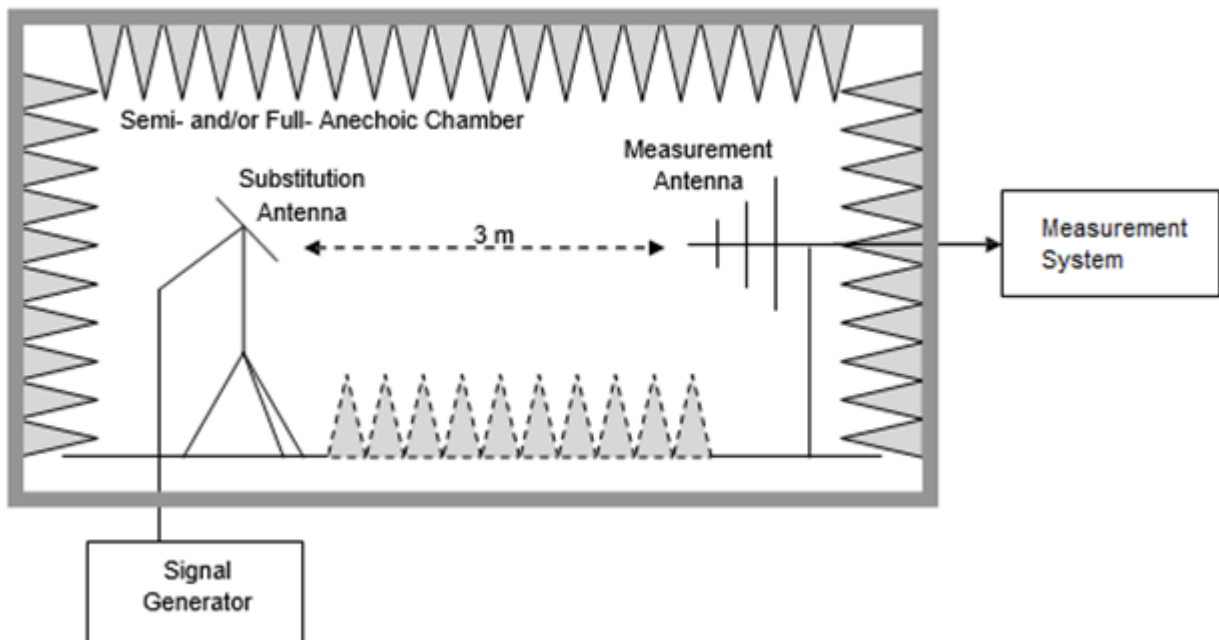

4.4 Test Conditions

Test Case		Test Conditions	
Transmit Output Power Data	Average Power, Total	Test Env.	Ambient Climate & Rated Voltage
		Test Setup	Test Setup 1
		RF Channels (TX)	L, M, H (L= low channel, M= middle channel, H= high channel)
		Test Mode	LTE/TM1, LTE/TM2
	Average Power, Spectral Density (if required)	Test Env.	Ambient Climate & Rated Voltage
		Test Setup	Test Setup 1
		RF Channels (TX)	L, M, H (L= low channel, M= middle channel, H= high channel)
		Test Mode	LTE/TM1,LTE/TM2
Peak-to-Average Ratio (if required)		Test Env.	Ambient Climate & Rated Voltage
		Test Setup	Test Setup 1
		RF Channels (TX)	L, M, H (L= low channel, M= middle channel, H= high channel)
		Test Mode	LTE/TM1,LTE/TM2
Bandwidth	Occupied Bandwidth	Test Env.	Ambient Climate & Rated Voltage
		Test Setup	Test Setup 1
		RF Channels (TX)	L, M, H (L= low channel, M= middle channel, H= high channel)
		Test Mode	LTE/TM1,LTE/TM2
	Emission Bandwidth (if required)	Test Env.	Ambient Climate & Rated Voltage
		Test Setup	Test Setup 1
		RF Channels (TX)	L, M, H (L= low channel, M= middle channel, H= high channel)
		Test Mode	LTE/TM1,LTE/TM2
Band Edges Compliance		Test Env.	Ambient Climate & Rated Voltage
		Test Setup	Test Setup 1
		RF Channels (TX)	L, H (L= low channel, M= middle channel, H= high channel)
		Test Mode	LTE/TM1,LTE/TM2
Spurious Emission at AntennaTerminals		Test Env.	Ambient Climate & Rated Voltage
		Test Setup	Test Setup 1
		RF Channels (TX)	L, M, H (L= low channel, M= middle channel, H= high channel)
		Test Mode	LTE/TM1,LTE/TM2
Field Strength of SpuriousRadiation		Test Env.	Ambient Climate & Rated Voltage
		Test Setup	Test Setup 3
		RF Channels (TX)	L, M, H (L= low channel, M= middle channel, H= high channel)
		Test Mode	LTE/TM1, LTE/TM2 NOTE: If applicable, the EUT conf. that has maximum



		power density (based on the equivalent power level) is selected.
Frequency Stability	Test Env.	(1) -30 °C to +50 °C with step 10 °C at Rated Voltage; (2) VL, VN and VH of Rated Voltage at Ambient Climate.
	Test Setup	Test Setup 2
	RF Channels (TX)	L, M, H (L= low channel, M= middle channel, H= high channel)
	Test Mode	LTE/TM1, LTE/TM2

5. Description of Tests

5.1 Effective (Isotropic) Radiated Power

Below 1GHz test procedure as below:

- 1). The EUT was powered ON and placed on a 0.8m high table in the chamber. The antenna of the transmitter was extended to its maximum length.
- 2). The disturbance of the transmitter was maximized on the test receiver display by raising and lowering from 1m to 4m the receive antenna and by rotating through 360° the turntable. After the fundamental emission was maximized, a field strength measurement was made.
- 3). Steps 1) and 2) were performed with the EUT and the receive antenna in both vertical and horizontal polarization.
- 4). The transmitter was then removed and replaced with another antenna. The center of the antenna was approximately at the same location as the center of the transmitter.
- 5). A signal at the disturbance was fed to the substitution antenna by means of a non-radiating cable. With both the substitution and the receive antennas horizontally polarized, the receive antenna was raised and lowered to obtain a maximum reading at the test receiver. The level of the signal generator was adjusted until the measured field strength level in step 2) is obtained for this set of conditions.
- 6). The output power into the substitution antenna was then measured.
- 7). Steps 5) and 6) were repeated with both antennas polarized.
- 8). Calculate power in dBm by the following formula: $ERP \text{ (dBm)} = Pg \text{ (dBm)} - \text{cable loss (dB)} + \text{antenna gain (dBd)}$ Where: Pg is the generator output power into the substitution antenna.

Above 1GHz test procedure as below:

- 1). Different between above is the test site, change from Semi- Anechoic Chamber to fully Anechoic Chamber
- 2). Calculate power in dBm by the following formula: $EIRP \text{ (dBm)} = Pg \text{ (dBm)} - \text{cable loss (dB)} + \text{antenna gain (dBi)}$ $EIRP = ERP + 2.15 \text{ dB}$ Where: Pg is the generator output power into the substitution antenna.
- 3). Test the EUT in the lowest channel, the middle channel the Highest channel
- 4). The radiation measurements are performed in X, Y, Z axis positioning. And found the X axis positioning which it is worse case, Only the test worst case mode is recorded in the report.
- 5). Repeat above procedures until all frequencies measured was complete.

Test Procedures Used

FCC KDB 971168 D01 V03r01 ; ANSI/ C63.10

Note: Reference test setup 3

Test Result

Please refer to AIT23040404FW5_Appendix _Test Data LTE-Band5:

Please refer to AIT23040404FW5_Appendix _Test Data LTE-Band7:

Please refer to AIT23040404FW5_Appendix _Test Data LTE-Band19:

Please refer to AIT23040404FW5_Appendix _Test Data LTE-Band26:

Please refer to AIT23040404FW5_Appendix _Test Data LTE-Band40:

Please refer to AIT23040404FW5_Appendix _Test Data LTE-Band41:

5.2 Peak-Average Ratio

A peak to average ratio measurement is performed at the conducted port of the EUT. For WCDMA signals, the spectrum analyzers Complementary Cumulative Distribution Function (CCDF) measurement profile is used to determine the largest deviation between the average and the peak power of the EUT in a given bandwidth. The CCDF curve shows how much time the peak waveform spends at or above a given average power level. The percent of time the signal spends at or above the level defines the probability for that particular power level. For GSM signals, an average and a peak trace are used on a spectrum analyzer to determine the largest deviation between the average and the peak power of the EUT in a bandwidth greater than the emission bandwidth. The traces are generated with the spectrum analyzer set to zero span mode.

Test Settings

1. The signal analyzer's CCDF measurement profile is enabled
2. Frequency = carrier center frequency
3. Measurement BW > Emission bandwidth of signal
4. The signal analyzer was set to collect one million samples to generate the CCDF curve
5. The measurement interval was set depending on the type of signal analyzed. For continuous signals (>98% duty cycle), the measurement interval was set to 1ms. For burst transmissions, the spectrum analyzer is set to use an internal "RF Burst" trigger that is synced with an incoming pulse and the measurement interval is set to less than the duration of the "on time" of one burst to ensure that energy is only captured during a time in which the transmitter is operating at maximum power

Test Procedures Used

FCC KDB 971168 D01 V03r01 Section 5.7.1

Note: Reference test setup 1

Test result

Please refer to AIT23040404FW5_Appendix _Test Data LTE-Band5:

Please refer to AIT23040404FW5_Appendix _Test Data LTE-Band7:

Please refer to AIT23040404FW5_Appendix _Test Data LTE-Band19:

Please refer to AIT23040404FW5_Appendix _Test Data LTE-Band26:

Please refer to AIT23040404FW5_Appendix _Test Data LTE-Band40:

Please refer to AIT23040404FW5_Appendix _Test Data LTE-Band41:

5.3 Occupied Bandwidth

The occupied bandwidth, that is the frequency bandwidth such that, below its lower and above its upper frequency limits, the mean powers radiated are each equal to 0.5 percent of the total mean power radiated by a given emission shall be measured. The transmitter output was connected to a calibrated coaxial cable, attenuator and Spectrum analyser, the other end of which was connected to a Base Station Simulator. The Base Station Simulator was set to force the EUT to its maximum power setting. The tests were performed at three frequencies (low channel, middle channel and high channel). The span of the analyzer shall be set to capture all products of the modulation process, including the emission skirts. The resolution bandwidth shall be set to as close to 1 percent of the selected span as is possible without being below 1 percent. The video bandwidth shall be set to 3 times the resolution bandwidth. Video averaging is not permitted. Where practical, a sampling detector shall be used since a peak or, peak hold, may produce a wider bandwidth than actual. The trace data points are recovered and are directly summed in linear terms. The recovered amplitude data points, beginning at the lowest frequency, are placed in a running sum until 0.5 percent of the total is reached and that frequency recorded. The process is repeated for the highest frequency data points. This frequency is recorded. The span between the two recorded frequencies is the occupied bandwidth.

Test Procedures Used:

FCC KDB 971168 D01 V03r01 Section 4.2

Test Settings

1. The signal analyzer's automatic bandwidth measurement capability was used to perform the 99% occupied bandwidth and the 26dB bandwidth. The bandwidth measurement was not influenced by any intermediate power nulls in the fundamental emission.
2. RBW = 1 – 5% of the expected OBW
3. VBW \geq 3 x RBW
4. Detector = Peak
5. Trace mode = max hold
6. Sweep = auto couple
7. The trace was allowed to stabilize
8. If necessary, steps 2 – 7 were repeated after changing the RBW such that it would be within 1 – 5% of the 99% occupied bandwidth observed in Step 7

Note: Reference test setup 1.

Test Result

Please refer to AIT23040404FW5_Appendix _Test Data LTE-Band5:

Please refer to AIT23040404FW5_Appendix _Test Data LTE-Band7:

Please refer to AIT23040404FW5_Appendix _Test Data LTE-Band19:

Please refer to AIT23040404FW5_Appendix _Test Data LTE-Band26:

Please refer to AIT23040404FW5_Appendix _Test Data LTE-Band40:

Please refer to AIT23040404FW5_Appendix _Test Data LTE-Band41:

5.4 Band Edge Compliance

The transmitter output was connected to a calibrated coaxial cable, attenuator and Spectrum analyser, the other end of which was connected to a Base Station Simulator. The Base Station Simulator was set to force the EUT to its maximum power setting. The tests were performed at three frequencies (low channel and high channel).in the 1MHz bands immediately outside and adjacent to the frequency block a resolution bandwidth of 100kHz or 1% of the emission bandwidth of the fundamental emission of the transmitter may be employed. The EUT emission bandwidth is measured as the width of the signal between two points, outside of which all emission are attenuated at least 26dB below the transmitter power. The video bandwidth of the spectrum analyzer was set at thrice the resolution bandwidth. Detector Mode was set to peak or peak hold power.

Test Procedures Used

FCC KDB 971168 D01 V03r01 Section 6.0

Test Settings

1. Start and stop frequency were set such that the band edge would be placed in the center of the plot
2. Span was set large enough so as to capture all out of band emissions near the band edge
3. RBW \geq 1% of the emission bandwidth
4. VBW \geq 3 x RBW
5. Detector = RMS
6. Number of sweep points \geq 2 x Span/RBW
7. Trace mode = trace average for continuous emissions, max hold for pulse emissions
8. Sweep time = auto couple
9. The trace was allowed to stabilize

Note: Reference test setup 1.

Test Result

Please refer to AIT23040404FW5_Appendix _Test Data LTE-Band5:

Please refer to AIT23040404FW5_Appendix _Test Data LTE-Band7:

Please refer to AIT23040404FW5_Appendix _Test Data LTE-Band19:

Please refer to AIT23040404FW5_Appendix _Test Data LTE-Band26:

Please refer to AIT23040404FW5_Appendix _Test Data LTE-Band40:

Please refer to AIT23040404FW5_Appendix _Test Data LTE-Band41:

5.5 Spurious and Harmonic Emissions at Antenna Terminal

The transmitter output was connected to a calibrated coaxial cable, attenuator and Spectrum analyzer, the other end of which was connected to a Base Station Simulator. The Base Station Simulator was set to force the EUT to its maximum power setting. The tests were performed at three frequencies (low channel and high channel). The level of the carrier and the various conducted spurious and harmonic frequencies is measured by means of a calibrated spectrum analyzer. The spectrum is scanned from the lowest frequency generated in the equipment up to a frequency including its 10th harmonic. On any frequency outside a licensee's frequency block, the power of any emission shall be attenuated below the transmitter power (P) by at least $43 + 10 \log(P)$ dB. Compliance with these provisions is based on the use of measurement instrumentation employing a resolution bandwidth of 1 MHz or greater. However, in the 1 MHz bands immediately outside and adjacent to the frequency block a resolution bandwidth of at least one percent of the emission bandwidth of the fundamental emission of the transmitter may be employed. The emission bandwidth is defined as the width of the signal between two points, one below the carrier center frequency and one above the carrier center frequency, outside of which all emission are attenuated at least 26 dB below the transmitter power.

Test Procedures Used

FCC KDB 971168 D01 V03r01

Test Settings

1. Start frequency was set to 30MHz and stop frequency was set to at least $10 \times$ the fundamental frequency (separated into at least two plots per channel)
2. Detector = RMS
3. Trace mode = trace average for continuous emissions, max hold for pulse emissions
4. Sweep time = auto couple
5. The trace was allowed to stabilize
6. Please see test notes below for RBW and VBW settings

Note: Reference test setup 1.

Test Result:

Please refer to AIT23040404FW5_Appendix _Test Data LTE-Band5:

Please refer to AIT23040404FW5_Appendix _Test Data LTE-Band7:

Please refer to AIT23040404FW5_Appendix _Test Data LTE-Band19:

Please refer to AIT23040404FW5_Appendix _Test Data LTE-Band26:

Please refer to AIT23040404FW5_Appendix _Test Data LTE-Band40:

Please refer to AIT23040404FW5_Appendix _Test Data LTE-Band41:

5.6 Field Strength of Spurious Radiation

PROVISIONS APPLICABLE:

(A) On any frequency outside a licensee's frequency block (e.g. A, D, B, etc.) within the USPCS spectrum, the power of any emission shall be attenuated below the transmitter power (P, in Watts) by at least $43+10\log(P)$ dB. The specification that emissions shall be attenuated below the transmitter power (P) by at least $43 + 10 \log(P)$ dB, translates in the relevant power range (1 to 0.001 W) to -13 dBm.

At 1 W the specified minimum attenuation becomes 43 dB and relative to a 30 dBm (1 W) carrier becomes a limit of -13 dBm. At 0.001 W (0 dBm) the minimum attenuation is 13 dB, which again yields a limit of -13 dBm. In this way a translation of the specification from relative to absolute terms is carried out.

(B) For specific criteria, please refer to the description in section 10.2 of the report for corresponding evaluation.

MEASUREMENT PROCEDURE:

- 1). The EUT was placed on the top of the turntable 0.8 or 1.5 meter above ground. The phase center of the receiving antenna mounted on the top of a height-variable antenna tower was placed 3 meters far away from the turntable.
- 2). Power on the EUT and all the supporting units. The turntable was rotated by 360 degrees to determine the position of the highest radiation.
- 3). The height of the broadband receiving antenna was varied between one meter and four meters above ground to find the maximum emissions field strength of both horizontal and vertical polarization.
- 4). For each suspected emissions, the antenna tower was scan (from 1 M to 4 M) and then the turntable was rotated (from 0 degree to 360 degrees) to find the maximum reading.
- 5). Set the test-receiver system to Peak or CISPR quasi-peak Detect Function with specified bandwidth under Maximum Hold Mode.
- 6). For emissions above 1GHz, use 1MHz VBW and RBW for peak reading. Then 1MHz RBW and 10Hz VBW for average reading in spectrum analyzer. Place the measurement antenna away from each area of the EUT determined to be a source of emissions at the specified measurement distance, while keeping the measurement antenna aimed at the source of emissions at each frequency of significant emissions, with polarization oriented for maximum response. The measurement antenna may have to be higher or lower than the EUT, depending on the radiation pattern of the emission and staying aimed at the emission source for receiving the maximum signal. The final measurement antenna elevation shall be that which maximizes the emissions. The measurement antenna elevation for maximum emissions shall be restricted to a range of heights of from 1 m to 4 m above the ground or reference ground plane.
- 7). When the radiated emissions limits are expressed in terms of the average value of the emissions, and pulsed operation is employed, the measurement field strength shall be determined by averaging over one complete pulse train, including blanking intervals, as long as the pulse train does not exceed 0.1 seconds. As an alternative (provided the transmitter operates for longer than 0.1 seconds) or in cases where the pulse train exceeds 0.1 seconds, the measured field strength shall be determined from the average absolute voltage during a 0.1 second interval during which the field strength is at its maximum values.
- 8). If the emissions level of the EUT in peak mode was 3 dB lower than the average limit specified, then testing will be stopped and peak values of EUT will be reported, otherwise, the emissions which do not have 3 dB margin will be repeated one by one using the quasi-peak method for below 1GHz.
- 9). For testing above 1GHz, the emissions level of the EUT in peak mode was lower than average limit

(that means the emissions level in peak mode also complies with the limit in average mode), then testing will be stopped and peak values of EUT will be reported, otherwise, the emissions will be measured in average mode again and reported.

10). In case the emission is lower than 30MHz, loop antenna has to be used for measurement and the recorded data should be QP measured by receiver. High - Low scan is not required in this case.

11). For spurious emissions above 1GHz, a horn antenna is substituted in place of the EUT. The substitute antenna is driven by a signal generator and the previously recorded signal was duplicated.

The spurious emissions is calculated by the following formula;

$$\text{Result(dBm)} = \text{Pg(dBm)} + \text{Factor(dB)}$$

$$\text{Factor(dB)} = \text{Ant Gain(dB)} - \text{Cable Loss(dB)} + \text{Power Splitter(dB)} \text{ (Above 1GHz)}$$

$$\text{Factor(dB)} = \text{Ant Gain(dB)} - \text{Cable Loss(dB)} \text{ (Below 1GHz)}$$

Where: P_g is the generator output power into the substitution antenna.

If the fundamental frequency is below 1GHz, RF output power has been converted to EIRP.

$$\text{EIRP(dBm)} = \text{ERP(dBm)} + 2.15$$

Examples of Factor parameters for testing radiation spurious:

FrequencyRange(MHz)	Factor(dB)
30-500	6.18
500-1000	9.37
1000-1500	27.56
1500-2000	28.27
2000-3000	29.45
3000-5000	30.15
5000-10000	31.26
10000-15000	32.78
15000-20000	33.99
Above 20GHz	35.04

Test Procedures Used

FCC KDB 971168 D01 V03r01; ANSI/ C63.10

Note: Reference test setup 3.

Test Result:

**LTE Band 5_TX Mode
Lowchannel**

Frequency (MHz)	Polarity (H/V)	Emission Level (dBm)	Limit (dBm)	Margin (dB)
5160	V	-40.31	-13	-27.31
3440	V	-40.35	-13	-27.35
745.5	V	-44.81	-13	-31.81
528.1	V	-48.56	-13	-35.56
5160	H	-40.75	-13	-27.75
3440	H	-41.18	-13	-28.18
520.5	H	-47.74	-13	-34.74
395.8	H	-44.19	-13	-31.19

Middlechannel

Frequency (MHz)	Polarity (H/V)	Emission Level (dBm)	Limit (dBm)	Margin (dB)
5197.5	V	-39.16	-13	-26.16
3465	V	-38.95	-13	-25.95
669.4	V	-47.23	-13	-34.23
512.5	V	-48.96	-13	-35.96
5197.5	H	-40.02	-13	-27.02
3465	H	-39.35	-13	-26.35
569.4	H	-48.21	-13	-35.21
469.3	H	-46.53	-13	-33.53

Highchannel

Frequency (MHz)	Polarity (H/V)	Emission Level (dBm)	Limit (dBm)	Margin (dB)
5235	V	-38.89	-13	-25.89
3490	V	-40.06	-13	-27.06
711.1	V	-48.57	-13	-35.57
528.7	V	-48.38	-13	-35.38
5235	H	-39.19	-13	-26.19
3490	H	-40.26	-13	-27.26
612.5	H	-46.35	-13	-33.35
553.9	H	-45.34	-13	-32.34

**LTE Band 7
Lowchannel**

Frequency (MHz)	Polarity (H/V)	Emission Level (dBm)	Limit (dBm)	Margin (dB)
7507.5	V	-44.14	-25	-19.14
5005	V	-43.41	-25	-18.41
925.7	V	-50.26	-25	-25.26
678.9	V	-52.95	-25	-27.95
7507.5	H	-42.95	-25	-17.95
5005	H	-43.14	-25	-18.14
873.6	H	-50.83	-25	-25.83
662.7	H	-52.58	-25	-27.58

Middlechannel

Frequency (MHz)	Polarity (H/V)	Emission Level (dBm)	Limit (dBc)	Margin (dB)
7605	V	-44.01	-25	-19.01
5070	V	-41.73	-25	-16.73
833.7	V	-51.41	-25	-26.41
521.2	V	-52.95	-25	-27.95
7605	H	-40.71	-25	-15.71
5070	H	-42.86	-25	-17.86
819.6	H	-51.43	-25	-26.43
520.5	H	-48.75	-25	-23.75

Highchannel

Frequency (MHz)	Polarity (H/V)	Emission Level (dBm)	Limit (dBm)	Margin (dB)
7702.5	V	-43.76	-25	-18.76
5135	V	-45.11	-25	-20.11
752.6	V	-53.86	-25	-28.86
511.4	V	-53.08	-25	-28.08
7702.5	H	-41.04	-25	-16.04
5135	H	-44.37	-25	-19.37
701.1	H	-51.00	-25	-26.00
507.1	H	-48.84	-25	-23.84

**LTE Band 19
Lowchannel**

Frequency (MHz)	Polarity (H/V)	Emission Level (dBm)	Limit (dBm)	Margin (dB)
2119.5	V	-27.18	-13	-28.71
1413	V	-33.73	-13	-33.20
652.8	V	-34.84	-13	-36.51
431.2	V	-31.82	-13	-34.43
2119.5	H	-26.19	-13	-27.90
1413	H	-34.22	-13	-38.40
547.1	H	-34.95	-13	-34.90
425.3	H	-35.66	-13	-32.56

Middlechannel

Frequency (MHz)	Polarity (H/V)	Emission Level (dBm)	Limit (dBm)	Margin (dB)
2130	V	-27.18	-13	-28.92
1420	V	-33.73	-13	-29.48
625.5	V	-34.84	-13	-33.63
498.3	V	-31.82	-13	-37.33
2130	H	-26.19	-13	-28.85
1420	H	-34.22	-13	-32.52
515.3	H	-34.95	-13	-37.28
412.5	H	-35.66	-13	-36.11

Highchannel

Frequency (MHz)	Polarity (H/V)	Emission Level (dBm)	Limit (dBm)	Margin (dB)
2140.5	V	-27.18	-13	-27.18
1427	V	-33.73	-13	-33.73
577.8	V	-34.84	-13	-34.84
412.3	V	-31.82	-13	-31.82
2140.5	H	-26.19	-13	-26.19
1427	H	-34.22	-13	-34.22
505.6	H	-34.95	-13	-34.95
401.4	H	-35.66	-13	-35.66

**LTE Band 26A_TX Mode
Lowchannel**

Frequency (MHz)	Polarity (H/V)	Emission Level (dBm)	Limit (dBm)	Margin (dB)
2494.5	V	-47.53	-13	-34.53
1663	V	-45.91	-13	-32.91
563.4	V	-48.47	-13	-35.47
315.0	V	-53.31	-13	-40.31
2494.5	H	-46.04	-13	-33.04
1663	H	-44.11	-13	-31.11
463.8	H	-54.25	-13	-41.25
367.5	H	-49.65	-13	-36.65

Middlechannel

Frequency (MHz)	Polarity (H/V)	Emission Level (dBm)	Limit (dBm)	Margin (dB)
2509.5	V	-44.76	-13	-31.76
1673	V	-45.82	-13	-32.82
654.5	V	-50.74	-13	-37.74
543.2	V	-53.54	-13	-40.54
2509.5	H	-44.66	-13	-31.66
1673	H	-45.70	-13	-32.70
615.8	H	-48.44	-13	-35.44
363.1	H	-53.51	-13	-40.51

Highchannel

Frequency (MHz)	Polarity (H/V)	Emission Level (dBm)	Limit (dBm)	Margin (dB)
2524.5	V	-45.36	-13	-32.36
1683	V	-43.61	-13	-30.61
526.8	V	-48.77	-13	-35.77
364.5	V	-51.88	-13	-38.88
2524.5	H	-44.87	-13	-31.87
1683	H	-43.92	-13	-30.92
683.4	H	-50.92	-13	-37.92
475.9	H	-49.63	-13	-36.63

**LTE Band 26B_TX Mode
Lowchannel**



Frequency (MHz)	Polarity (H/V)	Emission Level (dBm)	Limit (dBm)	Margin (dB)
2444.1	V	-50.27	-13	-37.27
1638	V	-49.10	-13	-36.10
842.3	V	-53.47	-13	-40.47
596.5	V	-55.66	-13	-42.66
2444.1	H	-48.57	-13	-35.57
1638	H	-47.23	-13	-34.23
774.5	H	-56.59	-13	-43.59
617.2	H	-51.44	-13	-38.44

Middlechannel

Frequency (MHz)	Polarity (H/V)	Emission Level (dBm)	Limit (dBm)	Margin (dB)
2457	V	-47.29	-13	-34.29
1638	V	-47.31	-13	-34.31
745.5	V	-53.74	-13	-40.74
512.8	V	-56.77	-13	-43.77
2457	H	-46.83	-13	-33.83
1638	H	-46.85	-13	-33.85
693.7	H	-50.57	-13	-37.57
497.2	H	-56.46	-13	-43.46

Highchannel

Frequency (MHz)	Polarity (H/V)	Emission Level (dBm)	Limit (dBm)	Margin (dB)
2469.9	V	-62.04	-13	-49.04
1646.6	V	-57.50	-13	-44.50
882.2	V	-63.56	-13	-50.56
694.7	V	-68.14	-13	-55.14
2469.9	H	-59.02	-13	-46.02
1646.6	H	-59.56	-13	-46.56
745.1	H	-65.64	-13	-52.64
569.3	H	-66.65	-13	-53.65

**LTE Band 40_TX Mode
Lowchannel**

Frequency (MHz)	Polarity (H/V)	Emission Level (dBm)	Limit (dBm)	Margin (dB)
5132.1	V	-43.04	-13	-30.04
3421.4	V	-42.10	-13	-29.10
698.3	V	-46.28	-13	-33.28
417.5	V	-48.73	-13	-35.73
5132.1	H	-42.19	-13	-29.19
3421.4	H	-42.80	-13	-29.80
504.9	H	-50.36	-13	-37.36
431.9	H	-47.65	-13	-34.65

Middlechannel

Frequency (MHz)	Polarity (H/V)	Emission Level (dBm)	Limit (dBm)	Margin (dB)
5235	V	-43.00	-13	-30.00
3490	V	-42.14	-13	-29.14
578.2	V	-48.18	-13	-35.18
345.7	V	-49.34	-13	-36.34
5235	H	-42.18	-13	-29.18
3490	H	-42.16	-13	-29.16
634.8	H	-46.71	-13	-33.71
412.9	H	-50.33	-13	-37.33

Highchannel

Frequency (MHz)	Polarity (H/V)	Emission Level (dBm)	Limit (dBm)	Margin (dB)
5337.9	V	-41.28	-13	-28.28
3558.6	V	-40.51	-13	-27.51
752.6	V	-46.42	-13	-33.42
546.1	V	-48.96	-13	-35.96
5337.9	H	-41.57	-13	-28.57
3558.6	H	-41.28	-13	-28.28
687.3	H	-47.81	-13	-34.81
436.6	H	-46.75	-13	-33.75

**LTEBand41_TX Mode
Lowchannel**

Frequency (MHz)	Polarity (H/V)	Emission Level (dBm)	Limit (dBm)	Margin (dB)
5580	V	-40.42	-13	-27.42
3720	V	-39.69	-13	-26.69
695.5	V	-47.11	-13	-34.11
412.1	V	-49.20	-13	-36.20
5580	H	-38.78	-13	-25.78
3720	H	-40.10	-13	-27.10
678.3	H	-47.39	-13	-34.39
452.1	H	-49.04	-13	-36.04

Middlechannel

Frequency (MHz)	Polarity (H/V)	Emission Level (dBm)	Limit (dBm)	Margin (dB)
5640	V	-40.22	-13	-27.22
3760	V	-39.16	-13	-26.16
885.1	V	-47.35	-13	-34.35
618.7	V	-48.50	-13	-35.50
5640	H	-48.20	-13	-35.20
3760	H	-40.84	-13	-27.84
851.3	H	-44.05	-13	-31.05
732.5	H	-47.89	-13	-34.89

Highchannel

Frequency (MHz)	Polarity (H/V)	Emission Level (dBm)	Limit (dBm)	Margin (dB)
5700	V	-40.44	-13	-27.44
3800	V	-41.05	-13	-28.05
664.5	V	-46.14	-13	-33.14
525.8	V	-45.39	-13	-32.39
5700	H	-38.99	-13	-25.99
3800	H	-38.27	-13	-25.27
669.8	H	-47.39	-13	-34.39
574.4	H	-47.01	-13	-34.01

Note:1. Margin (dB) = Emission Level(dBm) -Limit(dBm)

Emission Level(dBm)=Measurement Reading(dBm)+Factor(dB)

Factor(dB) = ANT Gain -Cable Loss + Power Splitter

-
2. The test refers to the value of Factor, please refer to the results listed in the test method in this section of the report.
 3. The radiated spurious emission has been tested with maximum bandwidth QPSK modulation, resource block size 1 and resource block offset 0.
 4. Below 30MHz, no spurious emission was found, and only the worst mode data above 30MHz is recorded in the report.

5.7 Frequency Stability / Temperature Variation

The frequency stability of the transmitter is measured by:

- a.) Temperature: The temperature is varied from -10°C to $+50^{\circ}\text{C}$ in 10°C increments using an environmental chamber.
- b.) Primary Supply Voltage: The primary supply voltage is varied from 85% to 115% of the nominal value for non hand-carried battery and AC powered equipment. For hand-carried, battery-powered equipment, primary supply voltage is reduced to the battery operating end point which shall be specified by the manufacturer. Specification – The frequency stability shall be sufficient to ensure that the fundamental emission stays within the authorized frequency block. The frequency stability of the transmitter shall be maintained within $\pm 0.00025\%$ (± 2.5 ppm) of the center frequency.

Time Period and Procedure:

1. The carrier frequency of the transmitter is measured at room temperature (20°C to provide a reference).
2. The equipment is turned on in a “standby” condition for fifteen minutes before applying power to the transmitter. Measurement of the carrier frequency of the transmitter is made within one minute after applying power to the transmitter.
3. Frequency measurements are made at 10°C intervals ranging from -10°C to $+50^{\circ}\text{C}$. A period of at least one half-hour is provided to allow stabilization of the equipment at each temperature level.

Test Procedures Used

Frequency stability testing is performed in accordance with the guidelines of FCC KDB 971168 D01 V03r01; ANSI/ C63.10

Note: Reference test setup 2.

Test Result

PASS

(END OF REPORT)