

RF TEST REPORT

FCC ID: 2ALKI-CS20-1

Product Name : Cloud Speaker
Test Model : CS20-1
Test Model : 
Applicant : Wuhan Tianyu Information Industry Co., Ltd.
Address : Huazhong University of Sci. & Tech., East Lake Dev. Zone, Wuhan
430223, Hubei, China
Manufacturer : Wuhan Tianyu Information Industry Co., Ltd.
Address : Huazhong University of Sci. & Tech., East Lake Dev. Zone, Wuhan
430223, Hubei, China
Date of Receipt : 2023.04.30
Date of Test : 2023.04.30~2023.06.20
Issued Date : 2023.06.20
Report Version : V1.0
Test Sample : Engineering Sample No.: AIT23042708-1
Standard(s) : FCC Part 22H & 24E & 27C Rules;
ANSI C63.26:2015

Lab: Dongguan Yaxu (AiT) Technology Limited
Add: No. 22, Jinqianling 3rd Street, Jitigang, Huangjiang, Dongguan,
Guangdong, China
Tel.: +86-769-8202 0499 Fax.: +86-769-8202 0495

This device described above has been tested by Dongguan Yaxu (AiT) Technology Limited and the test results show that the equipment under test (EUT) is in compliance with the FCC requirements. And it is applicable only to the tested sample identified in the report.

Note: This report shall not be reproduced except in full, without the written approval of Dongguan Yaxu (AiT) Technology Limited, this document may be altered or revised by Dongguan Yaxu (AiT) Technology Limited, personal only, and shall be noted in the revision of the document. This test report must not be used by the client to claim product endorsement.

Reviewed by: 
Simba huang

Approved by: 
Seal Chen

Table of Contents

1. General Information	5
1.1 Applicant.....	5
1.2 Manufacturer	5
Basic Description of Equipment Under Test	5
1.3 Technical Specification	6
2. Summary of Test Results.....	8
2.1 Application of Standard.....	8
2.2 Band4 (1710-1755MHz paired with 2110-2155MHz).....	8
3. General Test Frequency and Configuration.....	12
3.1 Test Modes	12
3.2 Test Frequency	12
3.3 Test Environment.....	14
3.4 Test Instruments	15
3.5 Measurement Uncertainty	16
3.6 Test Location	16
3.7 Deviation from Standards	16
3.8 Abnormalities from Standard Conditions	16
4. Test Setup and Conditions	17
4.1 Test Setup 1	17
4.2 Test Setup 2	17
4.3 Test Setup 3	18
Step 1: Pre-test.....	18
Step 2: Substitution method to verify the maximum ERP/EIRP	18
4.4 Test Conditions	19
5. Description of Tests	21
5.1 Effective (Isotropic) Radiated Power	21
5.2 Peak-Average Ratio	22
5.3 Occupied Bandwidth	23
5.4 Band Edge Compliance.....	24



5.5 Spurious and Harmonic Emissions at Antenna Terminal	25
5.6 Field Strength of Spurious Radiation	26
5.7 Frequency Stability / Temperature Variation	33



Revision History

Revision	Issue Date	Revisions	Revised By
V1.0	2023.06.20	Initial Issue	Seal Chen

1. General Information

1.1 Applicant

Wuhan Tianyu Information Industry Co., Ltd.

Huazhong University of Sci. & Tech., East Lake Dev. Zone, Wuhan 430223, Hubei, China

1.2 Manufacturer

Wuhan Tianyu Information Industry Co., Ltd.

Huazhong University of Sci. & Tech., East Lake Dev. Zone, Wuhan 430223, Hubei, China

Basic Description of Equipment Under Test

Items	Description
Equipment Name	Cloud Speaker
Trademark	
Test Model Number	CS20-1
Series Model	N/A
Difference Description	N/A
Battery	DC 3.8V4000mAhby Built-in Li-ion Battery
Antenna Type:	FPC antenna
Operating Temperature	-10~50℃
Hardware Version	V1.00
Software Version	V1.00
EUT Stage	<input type="radio"/> Product Unit <input checked="" type="radio"/> Final-Sample
Radio SystemType	LTE
Operating Band	Band 2,Band 4,Band 7,Band 12

1.3 Technical Specification

Characteristics	Description	
Radio System Type	LTE	
Supported Frequency Range	LTE BAND2	Transmission (TX): 1850 to 1910 MHz
		Receiving (RX): 1930 to 1990 MHz
	LTE BAND4	Transmission (TX): 1710 to 1755 MHz
		Receiving (RX): 2110 to 2155 MHz
	LTE BAND7	Transmission (TX): 2500 to 2570 MHz
		Receiving (RX): 2620 to 2690 MHz
LTE BAND12	Transmission (TX): 699 to 716 MHz	
	Receiving (RX): 729 to 746 MHz	
TX and RX Antenna Ports	TX & RX port:	1
	TX-only port:	0
	RX-only port:	1
Target TX Output Power	LTE BAND2:24.39dBm; LTE BAND4:24.39dBm; LTE BAND7:24.39dBm; LTE BAND12:24.39dBm;	
Antenna Gain:	LTE BAND2:1.51dBi; LTE BAND4:1.38dBi; LTE BAND7:0.69dBi; LTE BAND12:-2.23dBi;	
Supported Channel Bandwidth	LTE BAND2	1.4 MHz, 3 MHz, 5 MHz, 10 MHz, 15 MHz, 20 MHz
	LTE BAND4	1.4 MHz, 3 MHz, 5 MHz, 10 MHz, 15 MHz, 20 MHz
	LTE BAND7	5 MHz, 10 MHz, 15 MHz, 20 MHz
	LTE BAND12	1.4 MHz, 3 MHz, 5 MHz, 10 MHz
Designation of Emissions (Note: the necessary bandwidth of which is the worst value from the measured occupied bandwidths for each type of channel bandwidth configuration.)	LTE BAND2:	1M1G7D (1.4 MHz QPSK modulation), 1M09W7D (1.4 MHz 16QAM modulation) 2M70G7D (3 MHz QPSK modulation), 2M70W7D (3 MHz 16QAM modulation) 4M52G7D (5 MHz QPSK modulation), 4M51W7D (5 MHz 16QAM modulation) 8M98G7D (10 MHz QPSK modulation), 8M97W7D (10 MHz 16QAM modulation) 13M5G7D (15 MHz QPSK modulation), 13M5W7D (15 MHz 16QAM modulation) 17M9G7D (20 MHz QPSK modulation), 17M9W7D (20 MHz 16QAM modulation)
	LTE BAND4:	1M11G7D (1.4 MHz QPSK modulation), 1M11W7D (1.4 MHz 16QAM modulation) 2M69G7D (3 MHz QPSK modulation), 2M69W7D (3 MHz 16QAM modulation) 4M48G7D (5 MHz QPSK modulation)



Characteristics	Description	
		4M48W7D (5 MHz 16QAM modulation) 8M96G7D (10 MHz QPSK modulation) 8M97W7D (10 MHz 16QAM modulation) 13M5G7D (15 MHz QPSK modulation) 13M5W7D (15 MHz 16QAM modulation) 17M9G7D (20 MHz QPSK modulation) 18M0W7D (20 MHz 16QAM modulation)
	LTE BAND7:	4M53G7D (5 MHz QPSK modulation), 4M50W7D (5 MHz 16QAM modulation) 8M97G7D (10 MHz QPSK modulation), 8M96W7D (10 MHz 16QAM modulation) 13M4G7D (15 MHz QPSK modulation), 13M4W7D (15 MHz 16QAM modulation) 17M9G7D (20 MHz QPSK modulation), 17M9W7D (20 MHz 16QAM modulation)
	LTE BAND12:	1M1G7D (1.4 MHz QPSK modulation), 1M1W7D (1.4 MHz 16QAM modulation) 2M70G7D (3 MHz QPSK modulation), 2M70W7D (3 MHz 16QAM modulation) 4M50G7D (5 MHz QPSK modulation), 4M50W7D (5 MHz 16QAM modulation) 8M96G7D (10 MHz QPSK modulation), 8M98W7D (10 MHz 16QAM modulation)

2. Summary of Test Results

2.1 Application of Standard

47 CFR FCC Part 22

47 CFR FCC Part 24

47 CFR FCC Part 27

KDB 971168 D01 Power Meas License Digital Systems v03r01

ANSI C63.26:2015

Band2 (1850-1910MHz paired with 1930-1990MHz)

TestItem	FCCRule No.	Requirements	TestResult	Verdict (Note1)
Effective(Isotropic) RadiatedPowerOutput Data	Part 2.1046, 24.232	EIRP≤2W	AppendixA	Pass
Peak-AverageRatio	Part 2.1046, 24.232	Limit≤13dB	AppendixA	Pass
ModulationCharacteristics	Part 2.1047	Digitalmodulation	AppendixA	Pass
Bandwidth	Part 2.1049	OBW:Nolimit. EBW:Nolimit.	AppendixA	Pass
BandEdgesCompliance	Part 2.1051, 24.238	≤ -13 dBm/1%*EBW, in 1 MHz bands immediately outside and adjacent to the frequency block.	AppendixA	Pass
SpuriousEmissionat AntennaTerminals	Part 2.1051, 24.238	≤ -13 dBm/1 MHz, from 9 kHz to 10th harmonics but outside authorized operating frequency ranges.	AppendixA	Pass
FieldStrengthof Spurious Radiation	Part 2.1053, 24.238	≤ -13dBm/1MHz.	AppendixA	Pass
FrequencyStability	Part 2.1055, 24.235	≤ ±2.5ppm.	AppendixA	Pass

Note1: Fortheverdict,the“N/A”denotes“notapplicable”,the“N/T”denotes“nottested”.

Band4 (1710-1755MHz paired with 2110-2155MHz)

TestItem	FCC Rule No.	Requirements	TestResult	Verdict (Note1)
Effective(Isotropic) RadiatedPower OutputData	Part 2.1046, 27.50(d)	EIRP ≤ 1W	AppendixA	Pass
Peak-AverageRatio	Part 2.1046, 27.50(d)	Limit≤13 dB	AppendixB	Pass
Bandwidth	Part 2.1049	OBW:No limit. EBW:No limit.	AppendixC	Pass
BandEdges Compliance	Part 2.1051, 27.53(h)	≤ -13 dBm/1%*EBW, in1MHz bands immediately outsideandadjacentto the frequencyblock.	AppendixD	Pass
Spurious Emissionat AntennaTerminals	Part 2.1051, 27.53(h)	≤ -13 dBm/1MHz, from9 kHzto 10 th harmonicsbutoutsideauthorized operatingfrequencyranges.	AppendixE	Pass
FieldStrengthof SpuriousRadiation	Part 2.1053, 27.53(h)	≤ -13 dBm/1MHz.	AppendixF	Pass
FrequencyStability	Part 2.1055, 27.54	≤ ±2.5ppm.	AppendixG	Pass
Note1: For the verdict, the "N/A" denotes "not applicable", the "N/T" denotes "not tested".				

Band7 (2496-2690MHz paired with 2496-2690MHz)

TestItem	FCC Rule No.	Requirements	TestResult	Verdict (Note1)
Effective (Isotropic) Radiated Power Output Data	Part 2.1046 27.50(h)	EIRP ≤ 2W	Appendix Cof Bnad7, Appendix Fof Bnad41	Pass
Peak-Average Ratio	Part 27.50(a)	Limit≤13 dB	Appendix Cof Bnad7, Appendix Fof Bnad41	Pass
Modulation Characteristics	Part 2.1047	Digitalmodulation	Appendix Cof Bnad7, Appendix Fof Bnad41	Pass
Bandwidth	Part 2.1049	OBW:No limit. EBW:No limit.	Appendix Cof Bnad7,	Pass

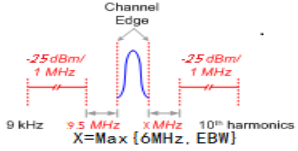
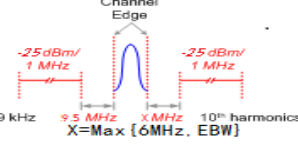
			Appendix Fof Bnad41	
Band Edges Compliance	Part 2.1051, 27.53(m4)	For mobile digital stations, the attenuation factor shall be not less than $40 + 10 \log (P)$ dB on all frequencies between the channel edge and 5 megahertz from the channel edge, $43 + 10 \log (P)$ dB on all frequencies between 5 megahertz and X megahertz from the channel edge, and $55 + 10 \log (P)$ dB on all frequencies more than X megahertz from the channel edge, where X is the greater of 6 megahertz or the actual emission bandwidth as defined in paragraph (m)(6) of this section.	Appendix Cof Bnad7, Appendix Fof Bnad41	Pass
Spurious Emission at Antenna Terminals	Part 2.1051, 27.53(m)		Appendix Cof Bnad7, Appendix Fof Bnad41	Pass
Field Strength of Spurious Radiation	Part 2.1053, 27.53(m)		Appendix Cof Bnad7, Appendix Fof Bnad41	Pass
Frequency Stability	Part 2.1055, 27.54	Within authorized bands of operation/frequency block.	Appendix Cof Bnad7, Appendix Fof Bnad41	Pass
Note1: For the verdict, the “N/A” denotes “not applicable”, the “N/T” denotes “not tested”.				

Band12 (633-716MHz paired with 729-746 MHz)

Test Item	FCC Rule No	Requirements	Test Result	Verdict (Note1)
Effective (Isotropic) Radiated Power Output Data	Part 27.50(c)	FCC: ERP ≤ 3 W.	Appendix Dof Bnad12, Appendix Hof Bnad71	Pass
Peak-Average Ratio	Part 2.1046, Part 27.50(c)	Limit≤13 dB	Appendix Dof Bnad12, Appendix Hof Bnad71	Pass
Modulation Characteristics	Part 2.1047	Digital modulation	Appendix Dof Bnad12, Appendix Hof Bnad71	Pass
Bandwidth	Part 2.1049	OBW: No limit. EBW: No limit.	Appendix Dof Bnad12, Appendix Hof Bnad7	Pass
Band Edges Compliance	Part 2.1051, Part 27.53(g) ,	≤ -13 dBm/1%*EBW, in 1 MHz bands immediately outside and adjacent to the frequency block.	Appendix Dof Bnad12, Appendix Hof Bnad71	Pass
Spurious Emission at Antenna Terminals	Part 2.1051, 27.53(g)	FCC: ≤ -13 dBm/100 kHz, from 9 kHz to 10th harmonics but outside authorized operating frequency ranges.	Appendix Dof Bnad12, Appendix Hof Bnad71	Pass
Field Strength of Spurious Radiation	Part 2.1053, 27.53(g)	FCC: ≤ -13 dBm/100 kHz.	Appendix Dof Bnad12, Appendix Hof Bnad71	Pass
Frequency Stability	Part 2.1055 27.54	≤ ±2.5ppm.	Appendix Dof Bnad12, Appendix Hof Bnad71	Pass
Note1: For the verdict, the “N/A” denotes “not applicable”, the “N/T” denotes “not tested”.				

3. General Test Frequency and Configuration

3.1 Test Modes

Test Mode	Test Modes Description
LTE/TM1	LTE system, QPSK modulation
LTE/TM2	LTE system, 16QAM modulation

3.2 Test Frequency

Test Mode	TX / RX	RF Channel		
		Low (B)	Middle (M)	High (T)
LTE Band 2	TX(1.4M)	Channel 18607	Channel 18900	Channel 19193
		1850.7 MHz	1880 MHz	1909.3 MHz
	TX(3M)	Channel 18615	Channel 18900	Channel 19185
		1851.5 MHz	1880 MHz	1908.5 MHz
	TX(5M)	Channel 18625	Channel 18900	Channel 19175
		1852.5 MHz	1880 MHz	1907.5 MHz
	TX(10M)	Channel 18650	Channel 18900	Channel 19150
		1855 MHz	1880 MHz	1905 MHz
	TX(15M)	Channel 18675	Channel 18900	Channel 19125
		1857.5 MHz	1880 MHz	1902.5 MHz
	TX(20M)	Channel 18700	Channel 18900	Channel 19100
		1860 MHz	1880 MHz	1900 MHz
	RX(1.4M)	Channel 607	Channel 900	Channel 1193
		1930.7 MHz	1960 MHz	1989.3 MHz
	RX(3M)	Channel 615	Channel 900	Channel 1185
		1931.5 MHz	1960 MHz	1988.5 MHz
	RX(5M)	Channel 625	Channel 900	Channel 1175
		1932.5 MHz	1960 MHz	1987.5 MHz
	RX(10M)	Channel 650	Channel 900	Channel 1150
		1935 MHz	1960 MHz	1985 MHz
RX(15M)	Channel 675	Channel 900	Channel 1125	
	1937.5 MHz	1960 MHz	1982.5 MHz	
RX(20M)	Channel 700	Channel 900	Channel 1100	
	1940 MHz	1960 MHz	1980 MHz	
Test Mode	TX / RX	RF Channel		
		Low (B)	Middle (M)	High (T)
LTE Band 4	TX(1.4M)	Channel 19957	Channel 20175	Channel 20393
		1710.7 MHz	1732.5 MHz	1754.3 MHz
	TX(3M)	Channel 19965	Channel 20175	Channel 20385
		1711.5 MHz	1732.5 MHz	1753.5 MHz



	TX(5M)	Channel 19975	Channel 20175	Channel 20375
		1712.5 MHz	1732.5 MHz	1752.5 MHz
	TX(10M)	Channel 20000	Channel 20175	Channel 20350
		1715 MHz	1732.5 MHz	1750 MHz
	TX(15M)	Channel 20025	Channel 20175	Channel 20325
		1717.5 MHz	1732.5 MHz	1747.5 MHz
	TX(20M)	Channel 20050	Channel 20175	Channel 20300
		1720 MHz	1732.5 MHz	1745 MHz
	RX(1.4M)	Channel 1975	Channel 2175	Channel 2375
		2112.5 MHz	2132.5MHz	2152.5 MHz
	RX(3M)	Channel 2000	Channel 2175	Channel 2350
		2115 MHz	2132.5MHz	2150 MHz
	RX(5M)	Channel 1975	Channel 2175	Channel 2375
		2112.5 MHz	2132.5MHz	2152.5 MHz
	RX(10M)	Channel 2000	Channel 2175	Channel 2350
		2115 MHz	2132.5MHz	2150 MHz
RX(15M)	Channel 2025	Channel 2175	Channel 2325	
	2117.5 MHz	2132.5MHz	2147.5 MHz	
RX(20M)	Channel 2050	Channel 2175	Channel 2300	
	2120 MHz	2132.5MHz	2145 MHz	
Test Mode	TX / RX	RF Channel		
		Low (B)	Middle (M)	High (T)
LTE Band 7	TX(5M)	CH20775	CH21100	CH21425
		2502.5MHz	2535MHz	2567.5MHz
	TX(10M)	CH20800	CH21100	CH21400
		2505MHz	2535MHz	2565MHz
	TX(15M)	CH20825	CH21100	CH21375
		2507.5MHz	2535MHz	2562.5MHz
	TX(20M)	CH20850	CH21100	CH21350
		2510MHz	2535MHz	2560MHz
	RX(5M)	Channel 2775	Channel 3100	Channel 5825
		2622.5 MHz	2655 MHz	2687.5 MHz
	RX (10M)	Channel 2800	Channel 3100	Channel 3400
		2625 MHz	2655 MHz	2685 MHz
	RX(15M)	Channel 2825	Channel 3100	Channel 3375
		2627.5 MHz	2655 MHz	2682.5 MHz
	RX (20M)	Channel 2850	Channel 3100	Channel 3350
		2630 MHz	2655 MHz	2680 MHz
Test Mode	TX / RX	RF Channel		
		Low (B)	Middle (M)	High (T)
LTE Band 12	TX(1.4M)	Channel 23017	Channel 23095	Channel 23173
		699.7 MHz	707.5 MHz	715.3 MHz
	TX(3M)	Channel 23025	Channel 23095	Channel 23165

		700.5 MHz	707.5 MHz	714.5 MHz
TX(5M)		Channel 23035	Channel 23095	Channel 23155
		701.5 MHz	707.5 MHz	713.5 MHz
TX(10M)		Channel 23060	Channel 23095	Channel 23130
		704 MHz	707.5 MHz	711 MHz
RX(1.4M)		Channel 5017	Channel 5095	Channel 5173
		729.7 MHz	737.5 MHz	745.3 MHz
RX (3M)		Channel 5025	Channel 5095	Channel 5165
		730.5 MHz	737.5 MHz	744.5 MHz
RX(5M)		Channel 5035	Channel 5095	Channel 5155
		731.5 MHz	737.5 MHz	743.5 MHz
RX (10M)		Channel 5060	Channel 5095	Channel 5130
		734 MHz	737.5 MHz	741 MHz

3.3 Test Environment

Applicable to	Environmental conditions	Input Power	Tested by
Transmitter Conducted Power Output	24.5°C, 52 % RH	120Vac, 60Hz	Simba Huang
Peak-Average Ratio	24.5°C, 52 % RH	120Vac, 60Hz	Simba Huang
Modulation Characteristics	24.5°C, 52 % RH	120Vac, 60Hz	Simba Huang
Bandwidth	24.5°C, 52 % RH	120Vac, 60Hz	Simba Huang
Emission Mask	24.5°C, 52 % RH	120Vac, 60Hz	Simba Huang
Spurious Emission at Antenna Terminals	24.5°C, 53 % RH	120Vac, 60Hz	Simba Huang
Field Strength of Spurious Radiation	24.4°C, 53 % RH	120Vac, 60Hz	Simba Huang
Frequency Stability	24.5°C, 52 % RH	120Vac, 60Hz	Simba Huang

The applicant declare the operating environment of EUT as below:

Normal conditions: 3.85V DC, 15°C ~35°C

Extreme conditions: 3.465V DC~4.235V DC, -10°C ~50°C

VL= lower extreme test voltage, VN= nominal voltage, VH= upper extreme test voltage

TL= lower extreme test temperature, TN= normal temperature, TH= upper extreme test temperature

3.4 Test Instruments

No	Test Equipment	Manufacturer	Model No	Serial No	Cal. Date	Cal. Due Date
1	Spectrum Analyzer	R&S	FSV40	101470	2022.09.02	2023.09.01
2	EMI Measuring Receiver	R&S	ESR	101660	2022.09.02	2023.09.01
3	Low Noise Pre Amplifier	HP	HP8447E	1937A01855	2022.09.02	2023.09.01
4	Low Noise Pre Amplifier	Tsj	MLA-0120-A02-34	2648A04738	2022.09.02	2023.09.01
5	Passive Loop	ETS	6512	00165355	2020.09.05	2022.09.04
6	TRILOG Super Broadband test Antenna	SCHWARZBEC K	VULB9160	9160-3206	2021.08.29	2024.08.28
7	Broadband Horn Antenna	SCHWARZBEC K	BBHA9120D	452	2021.08.29	2024.08.28
8	SHF-EHF Horn Antenna 15-40GHZ	SCHWARZBEC K	BBHA9170	BBHA9170367 d	2020.11.24	2023.11.23
9	EMI Test Receiver	R&S	ESCI	100124	2022.09.02	2023.09.01
10	LISN	Kyoritsu	KNW-242	8-837-4	2022.09.02	2023.09.01
11	LISN	R&S	ESH3-Z2	0357.8810.54- 101161-S2	2022.09.02	2023.09.01
12	Pro.Temp&Humi.chamber	MENTEK	MHP-150-1C	MAA08112501	2022.09.02	2023.09.01
13	RF Automatic Test system	MW	MW100-RFCB	21033016	2022.09.02	2023.09.01
14	Signal Generator	Agilent	N5182A	MY50143009	2022.09.02	2023.09.01
15	Wideband Radio communication tester	R&S	CMW500	1201.0002K50	2022.09.02	2023.09.01
16	RF Automatic Test system	MW	MW100-RFCB	21033016	2022.09.02	2023.09.01
17	DC power supply	ZHAOXIN	RXN-305D-2	28070002559	N/A	N/A
18	RE Software	EZ	EZ-EMC_RE	Ver.AIT-03A	N/A	N/A
19	CE Software	EZ	EZ-EMC_CE	Ver.AIT-03A	N/A	N/A
20	RF Software	MW	MTS 8310	2.0.0.0	N/A	N/A
21	temporary antenna connector(Note)	NTS	R001	N/A	N/A	N/A
22	Spectrum Analyzer	Agilent	N9020A	MT21033052	2022.09.02	2023.09.01

Note: The temporary antenna connector is soldered on the PCB board in order to perform conducted tests and this temporary antenna connector is listed in the equipment list.

3.5 Measurement Uncertainty

Where relevant, the following measurement uncertainty levels have been estimated for tests performed on the EUT.

This uncertainty represents an expanded uncertainty expressed at approximately the 95% confidence level using a coverage factor of k=2.

Uncertainty	
Parameter	Uncertainty
Occupied Channel Bandwidth	±142.08KHz
RF power conducted	±0.74dB
Band Edge Compliance	±1.24dB
Frequency stability	±0.12 ppm
Spurious emissions, radiated (0.009MHz~30MHz)	3.10dB
Spurious emissions, radiated (30MHz~1GHz)	3.75dB
Spurious emissions, radiated (1GHz~18GHz)	3.88dB
Spurious emissions, radiated (18GHz ~ 40GHz)	3.88dB
Humidity	±4.0%
Temperature	±0.5°C
Time	±1.20%

3.6 Test Location

Company:	Dongguan Yaxu (AiT) Technology Limited
Address:	No.22, Jinqianling 3rd Street, Jitigang, Huangjiang, Dongguan, Guangdong, China
CNAS Registration Number:	CNAS L14158
A2LA Registration Number:	6317.01
FCC Accredited Lab. Designation Number:	CN1313
FCC Test Firm Registration Number:	703111

3.7 Deviation from Standards

None

3.8 Abnormalities from Standard Conditions

None

4. Test Setup and Conditions

4.1 Test Setup 1

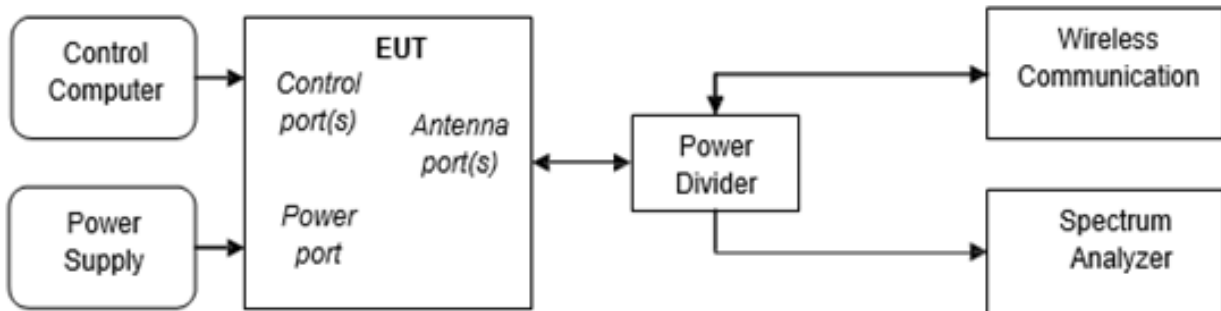

4.2 Test Setup 2

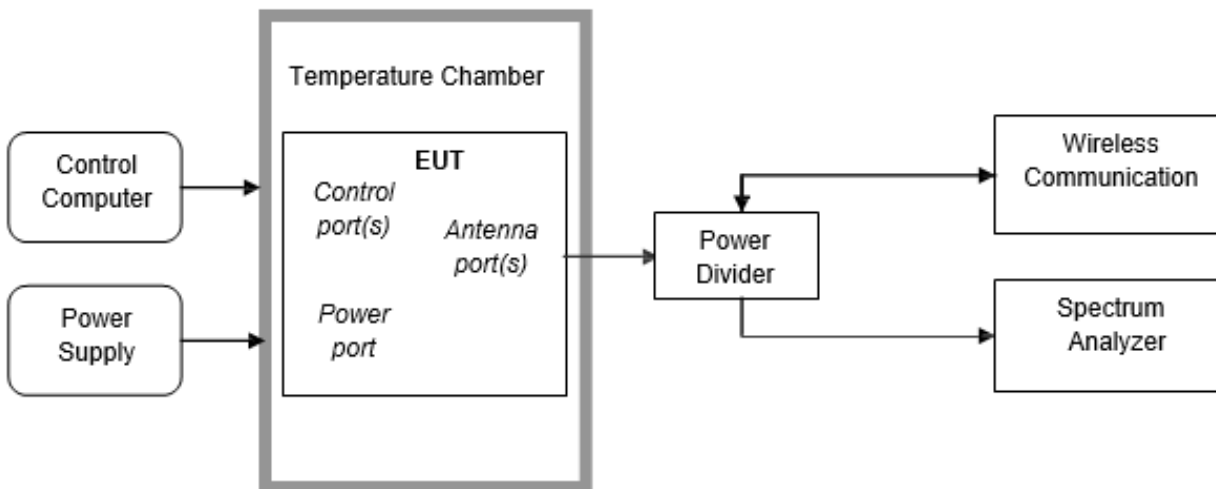

4.3 Test Setup 3

NOTE: Effective radiated power (ERP) and Equivalent Isotropic Radiated Power (EIRP) refers to the radiation power output of the EUT, assuming all emissions are radiated from half-wave dipole antennas.

Step 1: Pre-test

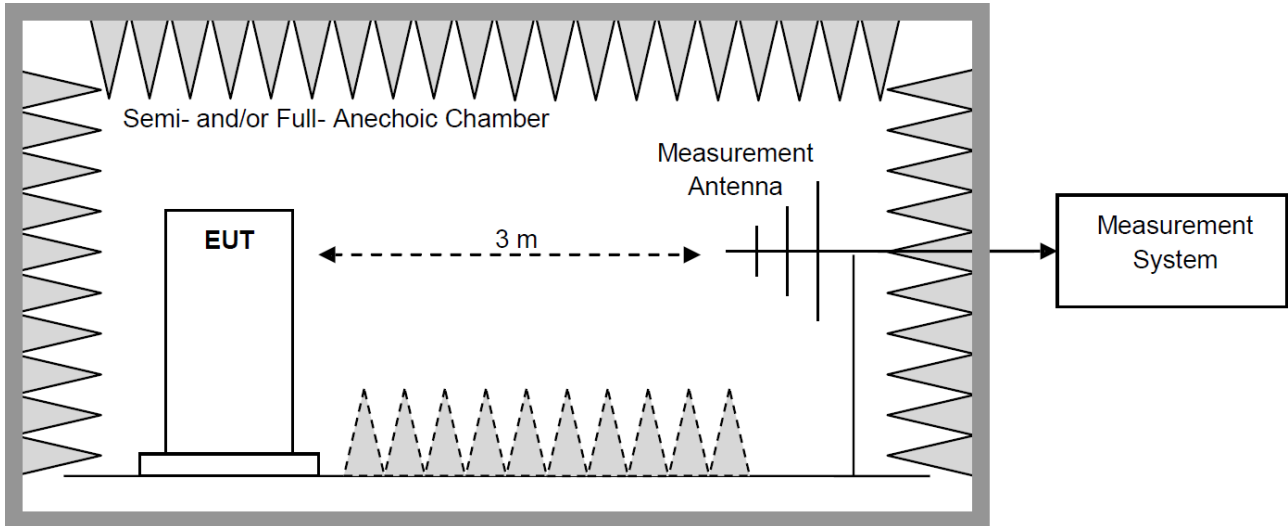

Step 2: Substitution method to verify the maximum ERP/EIRP

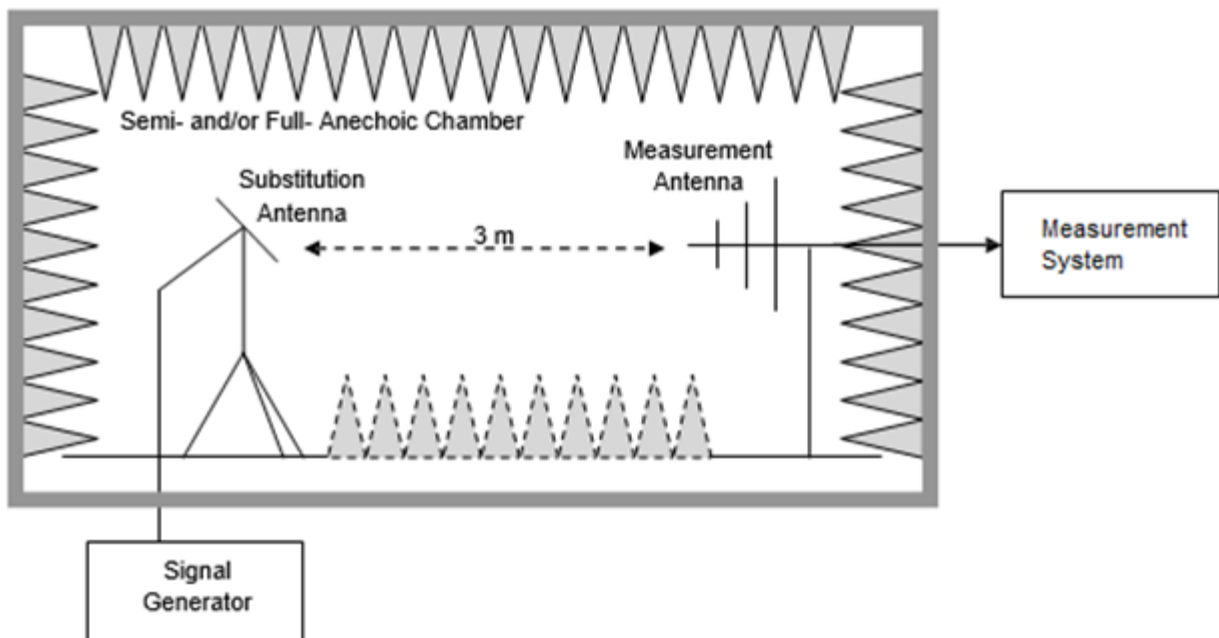

4.4 Test Conditions

Test Case		Test Conditions	
- Transmit - Output Power Data - -	Average Power, Total	Test Env.	Ambient Climate & Rated Voltage
		Test Setup	Test Setup 1
		RF Channels (TX)	L, M, H (L= low channel, M= middle channel, H= high channel)
		Test Mode	LTE/TM1, LTE/TM2
	Average Power, Spectral Density (if required)	Test Env.	Ambient Climate & Rated Voltage
		Test Setup	Test Setup 1
		RF Channels (TX)	L, M, H (L= low channel, M= middle channel, H= high channel)
		Test Mode	LTE/TM1,LTE/TM2
- Peak-to-Average Ratio (if required) -	Test Env.	Ambient Climate & Rated Voltage	
	Test Setup	Test Setup 1	
	RF Channels (TX)	L, M, H (L= low channel, M= middle channel, H= high channel)	
	Test Mode	LTE/TM1,LTE/TM2	
Bandwidth	Occupied Bandwidth	Test Env.	Ambient Climate & Rated Voltage
		Test Setup	Test Setup 1
		RF Channels (TX)	L, M, H (L= low channel, M= middle channel, H= high channel)
		Test Mode	LTE/TM1,LTE/TM2
	Emission Bandwidth (if required)	Test Env.	Ambient Climate & Rated Voltage
		Test Setup	Test Setup 1
		RF Channels (TX)	L, M, H (L= low channel, M= middle channel, H= high channel)
		Test Mode	LTE/TM1,LTE/TM2
Band Edges Compliance	Test Env.	Ambient Climate & Rated Voltage	
	Test Setup	Test Setup 1	
	RF Channels (TX)	L, H (L= low channel, M= middle channel, H= high channel)	
	Test Mode	LTE/TM1,LTE/TM2	
Spurious Emission at AntennaTerminals	Test Env.	Ambient Climate & Rated Voltage	
	Test Setup	Test Setup 1	
	RF Channels (TX)	L, M, H (L= low channel, M= middle channel, H= high channel)	
	Test Mode	LTE/TM1,LTE/TM2	
Field Strength of SpuriousRadiation	Test Env.	Ambient Climate & Rated Voltage	
	Test Setup	Test Setup 3	
	RF Channels (TX)	L, M, H (L= low channel, M= middle channel, H= high channel)	
	Test Mode	LTE/TM1, LTE/TM2	
		NOTE: If applicable, the EUT conf. that has maximum	



		power density (based on the equivalent power level) is selected.
Frequency Stability	Test Env.	(1) -30 °C to +50 °C with step 10 °C at Rated Voltage; (2) VL, VN and VH of Rated Voltage at Ambient Climate.
	Test Setup	Test Setup 2
	RF Channels (TX)	L, M, H (L= low channel, M= middle channel, H= high channel)
	Test Mode	LTE/TM1, LTE/TM2

5. Description of Tests

5.1 Effective (Isotropic) Radiated Power

Below 1GHz test procedure as below:

- 1). The EUT was powered ON and placed on a 0.8m high table in the chamber. The antenna of the transmitter was extended to its maximum length.
- 2). The disturbance of the transmitter was maximized on the test receiver display by raising and lowering from 1m to 4m the receive antenna and by rotating through 360° the turntable. After the fundamental emission was maximized, a field strength measurement was made.
- 3). Steps 1) and 2) were performed with the EUT and the receive antenna in both vertical and horizontal polarization.
- 4). The transmitter was then removed and replaced with another antenna. The center of the antenna was approximately at the same location as the center of the transmitter.
- 5). A signal at the disturbance was fed to the substitution antenna by means of a non-radiating cable. With both the substitution and the receive antennas horizontally polarized, the receive antenna was raised and lowered to obtain a maximum reading at the test receiver. The level of the signal generator was adjusted until the measured field strength level in step 2) is obtained for this set of conditions.
- 6). The output power into the substitution antenna was then measured.
- 7). Steps 5) and 6) were repeated with both antennas polarized.
- 8). Calculate power in dBm by the following formula: $ERP\ (dBm) = Pg\ (dBm) - \text{cable loss}\ (dB) + \text{antenna gain}\ (dBd)$ Where: Pg is the generator output power into the substitution antenna.

Above 1GHz test procedure as below:

- 1). Different between above is the test site, change from Semi- Anechoic Chamber to fully Anechoic Chamber
- 2). Calculate power in dBm by the following formula: $EIRP\ (dBm) = Pg\ (dBm) - \text{cable loss}\ (dB) + \text{antenna gain}\ (dBi)$ $EIRP = ERP + 2.15\ dB$ Where: Pg is the generator output power into the substitution antenna.
- 3). Test the EUT in the lowest channel, the middle channel the Highest channel
- 4). The radiation measurements are performed in X, Y, Z axis positioning. And found the X axis positioning which it is worse case, Only the test worst case mode is recorded in the report.
- 5). Repeat above procedures until all frequencies measured was complete.

Test Procedures Used

FCC KDB 971168 D01 V03r01 ; ANSI/ C63.10

Note: Reference test setup 3

Test Result

Please refer to AIT23042708FW7_Appendix H_Test Data LTE-Band4:

AIT23042708FW7_Appendix H. A

5.2 Peak-Average Ratio

A peak to average ratio measurement is performed at the conducted port of the EUT. For WCDMA signals, the spectrum analyzers Complementary Cumulative Distribution Function (CCDF) measurement profile is used to determine the largest deviation between the average and the peak power of the EUT in a given bandwidth. The CCDF curve shows how much time the peak waveform spends at or above a given average power level. The percent of time the signal spends at or above the level defines the probability for that particular power level. For GSM signals, an average and a peak trace are used on a spectrum analyzer to determine the largest deviation between the average and the peak power of the EUT in a bandwidth greater than the emission bandwidth. The traces are generated with the spectrum analyzer set to zero span mode.

Test Settings

1. The signal analyzer's CCDF measurement profile is enabled
2. Frequency = carrier center frequency
3. Measurement BW > Emission bandwidth of signal
4. The signal analyzer was set to collect one million samples to generate the CCDF curve
5. The measurement interval was set depending on the type of signal analyzed. For continuous signals (>98% duty cycle), the measurement interval was set to 1ms. For burst transmissions, the spectrum analyzer is set to use an internal "RF Burst" trigger that is synced with an incoming pulse and the measurement interval is set to less than the duration of the "on time" of one burst to ensure that energy is only captured during a time in which the transmitter is operating at maximum power

Test Procedures Used

FCC KDB 971168 D01 V03r01 Section 5.7.1

Note: Reference test setup 1

Test result

Please refer to AIT23042708FW7_Appendix H _Test Data LTE-Band4:

AIT23042708FW7_Appendix H. B

5.3 Occupied Bandwidth

The occupied bandwidth, that is the frequency bandwidth such that, below its lower and above its upper frequency limits, the mean powers radiated are each equal to 0.5 percent of the total mean power radiated by a given emission shall be measured. The transmitter output was connected to a calibrated coaxial cable, attenuator and Spectrum analyser, the other end of which was connected to a Base Station Simulator. The Base Station Simulator was set to force the EUT to its maximum power setting. The tests were performed at three frequencies (low channel, middle channel and high channel). The span of the analyzer shall be set to capture all products of the modulation process, including the emission skirts. The resolution bandwidth shall be set to as close to 1 percent of the selected span as is possible without being below 1 percent. The video bandwidth shall be set to 3 times the resolution bandwidth. Video averaging is not permitted. Where practical, a sampling detector shall be used since a peak or, peak hold, may produce a wider bandwidth than actual. The trace data points are recovered and are directly summed in linear terms. The recovered amplitude data points, beginning at the lowest frequency, are placed in a running sum until 0.5 percent of the total is reached and that frequency recorded. The process is repeated for the highest frequency data points. This frequency is recorded. The span between the two recorded frequencies is the occupied bandwidth.

Test Procedures Used:

FCC KDB 971168 D01 V03r01 Section 4.2

Test Settings

1. The signal analyzer's automatic bandwidth measurement capability was used to perform the 99% occupied bandwidth and the 26dB bandwidth. The bandwidth measurement was not influenced by any intermediate power nulls in the fundamental emission.
2. RBW = 1 – 5% of the expected OBW
3. VBW \geq 3 x RBW
4. Detector = Peak
5. Trace mode = max hold
6. Sweep = auto couple
7. The trace was allowed to stabilize
8. If necessary, steps 2 – 7 were repeated after changing the RBW such that it would be within 1 – 5% of the 99% occupied bandwidth observed in Step 7

Note: Reference test setup 1.

Test Result

Please refer to AIT23042708FW7_Appendix H_Test Data LTE-Band4:
AIT23042708FW7_Appendix H. C

5.4 Band Edge Compliance

The transmitter output was connected to a calibrated coaxial cable, attenuator and Spectrum analyser, the other end of which was connected to a Base Station Simulator. The Base Station Simulator was set to force the EUT to its maximum power setting. The tests were performed at three frequencies (low channel and high channel).in the 1MHz bands immediately outside and adjacent to the frequency block a resolution bandwidth of 100kHz or 1% of the emission bandwidth of the fundamental emission of the transmitter may be employed. The EUT emission bandwidth is measured as the width of the signal between two points, outside of which all emission are attenuated at least 26dB below the transmitter power. The video bandwidth of the spectrum analyzer was set at thrice the resolution bandwidth. Detector Mode was set to peak or peak hold power.

Test Procedures Used

FCC KDB 971168 D01 V03r01 Section 6.0

Test Settings

1. Start and stop frequency were set such that the band edge would be placed in the center of the plot
2. Span was set large enough so as to capture all out of band emissions near the band edge
3. RBW \geq 1% of the emission bandwidth
4. VBW \geq 3 x RBW
5. Detector = RMS
6. Number of sweep points \geq 2 x Span/RBW
7. Trace mode = trace average for continuous emissions, max hold for pulse emissions
8. Sweep time = auto couple
9. The trace was allowed to stabilize

Note: Reference test setup 1.

Test Result

Please refer to AIT23042708FW7_Appendix H _Test Data LTE-Band4:
AIT23042708FW7_Appendix H. D

5.5 Spurious and Harmonic Emissions at Antenna Terminal

The transmitter output was connected to a calibrated coaxial cable, attenuator and Spectrum analyzer, the other end of which was connected to a Base Station Simulator. The Base Station Simulator was set to force the EUT to its maximum power setting. The tests were performed at three frequencies (low channel and high channel). The level of the carrier and the various conducted spurious and harmonic frequencies is measured by means of a calibrated spectrum analyzer. The spectrum is scanned from the lowest frequency generated in the equipment up to a frequency including its 10th harmonic. On any frequency outside a licensee's frequency block, the power of any emission shall be attenuated below the transmitter power (P) by at least $43 + 10 \log(P)$ dB. Compliance with these provisions is based on the use of measurement instrumentation employing a resolution bandwidth of 1 MHz or greater. However, in the 1 MHz bands immediately outside and adjacent to the frequency block a resolution bandwidth of at least one percent of the emission bandwidth of the fundamental emission of the transmitter may be employed. The emission bandwidth is defined as the width of the signal between two points, one below the carrier center frequency and one above the carrier center frequency, outside of which all emission are attenuated at least 26 dB below the transmitter power.

Test Procedures Used

FCC KDB 971168 D01 V03r01

Test Settings

1. Start frequency was set to 30MHz and stop frequency was set to at least 10 * the fundamental frequency (separated into at least two plots per channel)
2. Detector = RMS
3. Trace mode = trace average for continuous emissions, max hold for pulse emissions
4. Sweep time = auto couple
5. The trace was allowed to stabilize
6. Please see test notes below for RBW and VBW settings

Note: Reference test setup 1.

Test Result:

Please refer to AIT23042708FW7_Appendix H_Test Data LTE-Band4:
AIT23042708FW7_Appendix H. E

5.6 Field Strength of Spurious Radiation

PROVISIONS APPLICABLE:

(A) On any frequency outside a licensee's frequency block (e.g. A, D, B, etc.) within the USPCS spectrum, the power of any emission shall be attenuated below the transmitter power (P, in Watts) by at least $43+10\log(P)$ dB. The specification that emissions shall be attenuated below the transmitter power (P) by at least $43 + 10 \log (P)$ dB, translates in the relevant power range (1 to 0.001 W) to -13 dBm.

At 1 W the specified minimum attenuation becomes 43 dB and relative to a 30 dBm (1 W) carrier becomes a limit of -13 dBm. At 0.001 W (0 dBm) the minimum attenuation is 13 dB, which again yields a limit of -13 dBm. In this way a translation of the specification from relative to absolute terms is carried out.

(B) For specific criteria, please refer to the description in section 10.2 of the report for corresponding evaluation.

MEASUREMENT PROCEDURE:

- 1). The EUT was placed on the top of the turntable 0.8 or 1.5 meter above ground. The phase center of the receiving antenna mounted on the top of a height-variable antenna tower was placed 3 meters far away from the turntable.
- 2). Power on the EUT and all the supporting units. The turntable was rotated by 360 degrees to determine the position of the highest radiation.
- 3). The height of the broadband receiving antenna was varied between one meter and four meters above ground to find the maximum emissions field strength of both horizontal and vertical polarization.
- 4). For each suspected emissions, the antenna tower was scan (from 1 M to 4 M) and then the turntable was rotated (from 0 degree to 360 degrees) to find the maximum reading.
- 5). Set the test-receiver system to Peak or CISPR quasi-peak Detect Function with specified bandwidth under Maximum Hold Mode.
- 6). For emissions above 1GHz, use 1MHz VBW and RBW for peak reading. Then 1MHz RBW and 10Hz VBW for average reading in spectrum analyzer. Place the measurement antenna away from each area of the EUT determined to be a source of emissions at the specified measurement distance, while keeping the measurement antenna aimed at the source of emissions at each frequency of significant emissions, with polarization oriented for maximum response. The measurement antenna may have to be higher or lower than the EUT, depending on the radiation pattern of the emission and staying aimed at the emission source for receiving the maximum signal. The final measurement antenna elevation shall be that which maximizes the emissions. The measurement antenna elevation for maximum emissions shall be restricted to a range of heights of from 1 m to 4 m above the ground or reference ground plane.
- 7). When the radiated emissions limits are expressed in terms of the average value of the emissions, and pulsed operation is employed, the measurement field strength shall be determined by averaging over one complete pulse train, including blanking intervals, as long as the pulse train does not exceed 0.1 seconds. As an alternative (provided the transmitter operates for longer than 0.1 seconds) or in cases where the pulse train exceeds 0.1 seconds, the measured field strength shall be determined from the average absolute voltage during a 0.1 second interval during which the field strength is at its maximum values.
- 8). If the emissions level of the EUT in peak mode was 3 dB lower than the average limit specified, then testing will be stopped and peak values of EUT will be reported, otherwise, the emissions which do not have 3 dB margin will be repeated one by one using the quasi-peak method for below 1GHz.

- 9). For testing above 1GHz, the emissions level of the EUT in peak mode was lower than average limit (that means the emissions level in peak mode also complies with the limit in average mode), then testing will be stopped and peak values of EUT will be reported, otherwise, the emissions will be measured in average mode again and reported.
- 10). In case the emission is lower than 30MHz, loop antenna has to be used for measurement and the recorded data should be QP measured by receiver. High - Low scan is not required in this case.
- 11). For spurious emissions above 1GHz, a horn antenna is substituted in place of the EUT. The substitute antenna is driven by a signal generator and the previously recorded signal was duplicated.

The spurious emissions is calculated by the following formula;

$$\text{Result(dBm)} = \text{Pg(dBm)} + \text{Factor(dB)}$$

$$\text{Factor(dB)} = \text{Ant Gain(dB)} - \text{Cable Loss(dB)} + \text{Power Splitter(dB)} \text{ (Above 1GHz)}$$

$$\text{Factor(dB)} = \text{Ant Gain(dB)} - \text{Cable Loss(dB)} \text{ (Below 1GHz)}$$

Where: P_g is the generator output power into the substitution antenna.

If the fundamental frequency is below 1GHz, RF output power has been converted to EIRP.

$$\text{EIRP(dBm)} = \text{ERP(dBm)} + 2.15$$

Examples of Factor parameters for testing radiation spurious:

FrequencyRange(MHz)	Factor(dB)
30-500	6.18
500-1000	9.37
1000-1500	27.56
1500-2000	28.27
2000-3000	29.45
3000-5000	30.15
5000-10000	31.26
10000-15000	32.78
15000-20000	33.99
Above 20GHz	35.04

Test Procedures Used

FCC KDB 971168 D01 V03r01; ANSI/ C63.10

Note: Reference test setup 3.

Test Result:

**LTEBand2_TX Mode
Lowchannel**

Frequency (MHz)	Polarity (H/V)	Emission Level (dBm)	Limit (dBm)	Margin (dB)
5580	V	-42.37	-13	-29.37
3720	V	-40.27	-13	-27.27
695.5	V	-47.47	-13	-34.47
412.1	V	-49.53	-13	-36.53
5580	H	-39.60	-13	-26.60
3720	H	-40.46	-13	-27.46
678.3	H	-48.19	-13	-35.19
452.1	H	-49.74	-13	-36.74

Middlechannel

Frequency (MHz)	Polarity (H/V)	Emission Level (dBm)	Limit (dBm)	Margin (dB)
5640	V	-41.82	-13	-28.82
3760	V	-40.12	-13	-27.12
885.1	V	-47.23	-13	-34.23
618.7	V	-48.23	-13	-35.23
5640	H	-48.75	-13	-35.75
3760	H	-41.91	-13	-28.91
851.3	H	-45.49	-13	-32.49
732.5	H	-48.24	-13	-35.24

Highchannel

Frequency (MHz)	Polarity (H/V)	Emission Level (dBm)	Limit (dBm)	Margin (dB)
5700	V	-41.76	-13	-28.76
3800	V	-41.68	-13	-28.68
664.5	V	-47.96	-13	-34.96
525.8	V	-46.98	-13	-33.98
5700	H	-39.61	-13	-26.61
3800	H	-39.70	-13	-26.70
669.8	H	-47.77	-13	-34.77
574.4	H	-47.36	-13	-34.36

**LTE Band 4_TX Mode
Lowchannel**

Frequency (MHz)	Polarity (H/V)	Emission Level (dBm)	Limit (dBm)	Margin (dB)
5160	V	-39.37	-13	-26.37
3440	V	-39.45	-13	-26.45
745.5	V	-44.62	-13	-31.62
528.1	V	-48.12	-13	-35.12
5160	H	-40.00	-13	-27.00
3440	H	-40.52	-13	-27.52
520.5	H	-47.51	-13	-34.51
395.8	H	-43.25	-13	-30.25

Middlechannel

Frequency (MHz)	Polarity (H/V)	Emission Level (dBm)	Limit (dBm)	Margin (dB)
5197.5	V	-38.24	-13	-25.24
3465	V	-38.90	-13	-25.90
669.4	V	-46.39	-13	-33.39
512.5	V	-48.41	-13	-35.41
5197.5	H	-39.26	-13	-26.26
3465	H	-39.14	-13	-26.14
569.4	H	-47.31	-13	-34.31
469.3	H	-45.96	-13	-32.96

Highchannel

Frequency (MHz)	Polarity (H/V)	Emission Level (dBm)	Limit (dBm)	Margin (dB)
5235	V	-38.54	-13	-25.54
3490	V	-39.76	-13	-26.76
711.1	V	-48.19	-13	-35.19
528.7	V	-47.99	-13	-34.99
5235	H	-38.42	-13	-25.42
3490	H	-39.28	-13	-26.28
612.5	H	-45.55	-13	-32.55
553.9	H	-45.05	-13	-32.05

LTE Band 7_TX Mode

Low channel

Frequency (MHz)	Polarity (H/V)	Emission Level (dBm)	Limit (dBm)	Margin (dB)
2487	V	-40.05	-25	-27.05
1658	V	-41.99	-25	-28.99
512.2	V	-45.70	-25	-32.70
365.5	V	-46.11	-25	-33.11
2487	H	-39.67	-25	-26.67
1658	H	-39.41	-25	-26.41
521.1	H	-44.33	-25	-31.33
336.5	H	-44.30	-25	-31.30

Middle channel

Frequency (MHz)	Polarity (H/V)	Emission Level (dBm)	Limit (dBm)	Margin (dB)
2509.5	V	-41.81	-25	-28.81
1673	V	-42.49	-25	-29.49
725.8	V	-45.57	-25	-32.57
616.6	V	-46.11	-25	-33.11
2509.5	H	-40.80	-25	-27.80
1673	H	-41.37	-25	-28.37
705.5	H	-45.36	-25	-32.36
558.9	H	-45.08	-25	-32.08

High channel

Frequency (MHz)	Polarity (H/V)	Emission Level (dBm)	Limit (dBm)	Margin (dB)
2532	V	-39.12	-25	-26.12
1688	V	-39.80	-25	-26.80
648.3	V	-45.53	-25	-32.53
482.7	V	-45.66	-25	-32.66
2532	H	-40.05	-25	-27.05
1688	H	-40.01	-25	-27.01
785.6	H	-45.80	-25	-32.80
615.7	H	-47.38	-25	-34.38

**LTE Band 12_TX Mode
Lowchannel**

Frequency (MHz)	Polarity (H/V)	Emission Level (dBm)	Limit (dBm)	Margin (dB)
2112.0	V	-41.89	-13	-28.89
1408	V	-40.60	-13	-27.60
658.1	V	-49.79	-13	-36.79
516.9	V	-49.27	-13	-36.27
2112	H	-41.10	-13	-28.10
1408	H	-41.20	-13	-28.20
714.4	H	-48.02	-13	-35.02
669.5	H	-47.99	-13	-34.99

Middlechannel

Frequency (MHz)	Polarity (H/V)	Emission Level (dBm)	Limit (dBm)	Margin (dB)
2122.5	V	-43.24	-13	-30.24
1415	V	-42.87	-13	-29.87
651.5	V	-47.62	-13	-34.62
512.7	V	-49.85	-13	-36.85
2122.5	H	-42.76	-13	-29.76
1415	H	-43.03	-13	-30.03
525.4	H	-48.75	-13	-35.75
498.7	H	-49.21	-13	-36.21

Highchannel

Frequency (MHz)	Polarity (H/V)	Emission Level (dBm)	Limit (dBm)	Margin (dB)
2133	V	-43.52	-13	-30.52
1422	V	-42.90	-13	-29.90
653.3	V	-47.00	-13	-34.00
592.7	V	-48.16	-13	-35.16
2133	H	-43.48	-13	-30.48
1422	H	-43.86	-13	-30.86
641.5	H	-50.84	-13	-37.84
558.3	H	-48.76	-13	-35.76

Note:1. Margin (dB) = Emission Level(dBm) -Limit(dBm)

Emission Level(dBm)=Measurement Reading(dBm)+Factor(dB)

Factor(dB) = ANT Gain -Cable Loss + Power Splitter

-
2. The test refers to the value of Factor, please refer to the results listed in the test method in this section of the report.
 3. The radiated spurious emission has been tested with maximum bandwidth QPSK modulation, resource block size 1 and resource block offset 0.
 4. Below 30MHz, no spurious emission was found, and only the worst mode data above 30MHz is recorded in the report.

5.7 Frequency Stability / Temperature Variation

The frequency stability of the transmitter is measured by:

- a.) Temperature: The temperature is varied from -10°C to +50°C in 10°C increments using an environmental chamber.
- b.) Primary Supply Voltage: The primary supply voltage is varied from 85% to 115% of the nominal value for non hand-carried battery and AC powered equipment. For hand-carried, battery-powered equipment, primary supply voltage is reduced to the battery operating end point which shall be specified by the manufacturer. Specification – The frequency stability shall be sufficient to ensure that the fundamental emission stays within the authorized frequency block. The frequency stability of the transmitter shall be maintained within $\pm 0.00025\%$ (± 2.5 ppm) of the center frequency.

Time Period and Procedure:

1. The carrier frequency of the transmitter is measured at room temperature (20°C to provide a reference).
2. The equipment is turned on in a “standby” condition for fifteen minutes before applying power to the transmitter. Measurement of the carrier frequency of the transmitter is made within one minute after applying power to the transmitter.
3. Frequency measurements are made at 10°C intervals ranging from -10°C to +50°C. A period of at least one half-hour is provided to allow stabilization of the equipment at each temperature level.

Test Procedures Used

Frequency stability testing is performed in accordance with the guidelines of FCC KDB 971168 D01 V03r01; ANSI/ C63.10

Note: Reference test setup 2.

Test Result

PASS

(END OF REPORT)