

# HAN NETWORKS AP211H Installation Guide

XXXX Rev. A

\*XXXXXX Rev. A\*

## Introduction

The Multi-functional AP211H access point is a highly versatile, and performance rich access point providing operational simplicity and a quality user experience. The AP211H indoor WiFi access point provides high-performance Gigabit WiFi for in-room applications such as hotels, classrooms, dormitories, clinics, remote/home office and more.

The AP211H offers Gigabit ethernet uplink, 3x Gigabit downlink one of which supports 802.3af PSE to power the attached device, one pair of RJ-45 pass through ports, and a USB 2.0 port.

The AP211H ships with a mounting plate to attach the AP to a single-gang wall-box (most international variations covered). A desk mount kit can be ordered separately.

## Package Contents

Figure 1

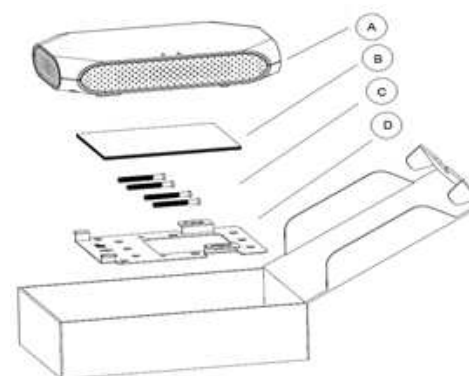

- A. AP211H Access Point
- B. Documents:
  - 1) Installation Guide (this document)
  - 2) Quick Start Guide
  - 3) User Guide Info Card
  - 4) Regulatory Compliance and Safety Information
- C. (2x) #6-32 slotted screws & (2x) M4 Phillips screws  
【backup for different country usage】
- D. Single-gang wall-box mounting plate

Inform your supplier if there are any incorrect, missing, or damaged parts. If possible, retain the carton, including the original packing materials. Use these materials to repack and return the unit to the supplier if needed.

## Hardware Overview

The following sections outline the hardware components of the AP211H access point.

Figure 2 AP211H Front View

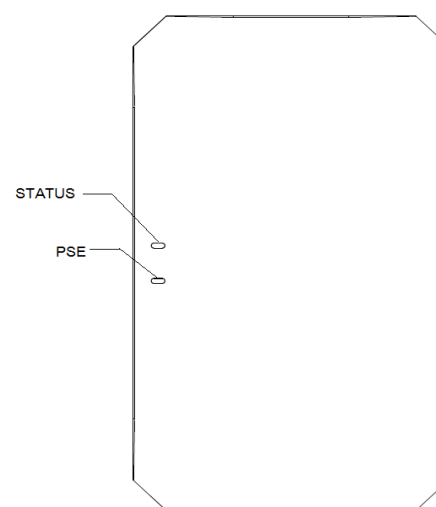

### LED

The LED displays located on the front of the access point indicate the following functions:

**STATUS:** System status (Tri-color LED)

**PSE:** PoE-PSE status

For the details of the LED status, please refer to the Quick Start Guide.

Figure 3 AP211H Rear View

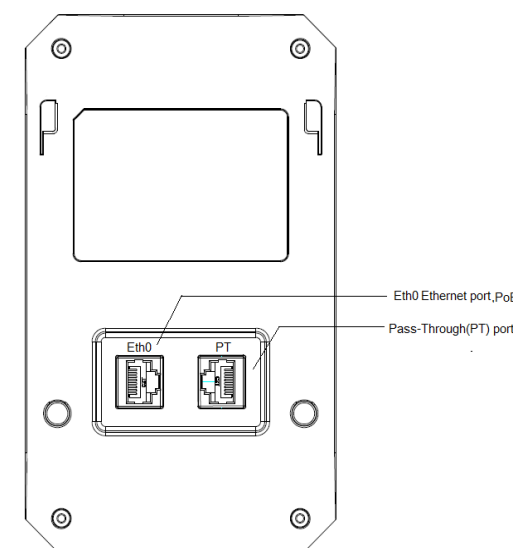

### Ethernet Ports

The AP211H access point is equipped with four active Ethernet ports. One is shown in Figure 3 (Eth0) and the others are shown in Figure 4 (Eth1-Eth3/PSE).

In addition, the AP211H AP has one pair of RJ-45 passive pass through ports, which provide an electrical connection between the back and the bottom of the access point.

Figure 4 AP211H Bottom View

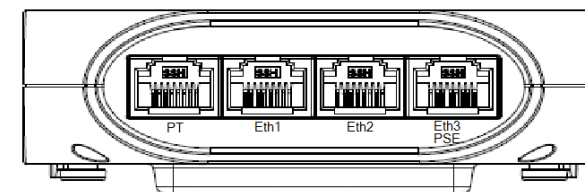

Table 1

Interface	Description
Eth0	1 × 10/100/1000Base-T auto-sensing uplink connectivity (RJ-45) port. IEEE 802.3af/802.3at PoE compliant.
Eth1- -Eth2	2 × 10/100/1000Base-T auto-sensing downlink connectivity (RJ-45) ports.
☆Eth3/PSE	1 × 10/100/1000Base-T auto-sensing downlink connectivity (RJ-45) port. IEEE 802.3af PoE-PSE compliant.
PT	One pair passive Pass-Through ports (two RJ-45, back and bottom)

☆ Note: When the AP211H is powered by an 802.3at or DC power source, the PoE-out (PoE-PSE) functionality could be enabled on port Eth3/PSE, supplying (1) maximum output of 12W while USB is active, or (2) maximum output of 802.3af PSE while USB is inactive.

Figure 5 Gigabit Ethernet Port Pin-Out

Table 2  
Eth0 Port Pinout

Connector	Pin	Signal Name	Function
	1	BI_DA+	Bi-directional pair +A, PoE Negative
	2	BI_DA-	Bi-directional pair -A, PoE Negative
	3	BI_DB+	Bi-directional pair +B, PoE Positive
	4	BI_DC+	Bi-directional pair +C, PoE Positive
	5	BI_DC-	Bi-directional pair -C, PoE Positive
	6	BI_DB-	Bi-directional pair -B, PoE Positive
	7	BI_DD+	Bi-directional pair +D, PoE Negative
	8	BI_DD-	Bi-directional pair -D, PoE Negative

Table 3

Eth1-Eth2 Port Pinout

Connector	Pin	Signal Name	Function
	1	BI_DA+	Bi-directional pair +A
	2	BI_DA-	Bi-directional pair -A
	3	BI_DB+	Bi-directional pair +B
	4	BI_DC+	Bi-directional pair +C
	5	BI_DC-	Bi-directional pair -C
	6	BI_DB-	Bi-directional pair -B
	7	BI_DD+	Bi-directional pair +D
	8	BI_DD-	Bi-directional pair -D

Table 4

Eth3/PSE Port Pinout

Connector	Pin	Signal Name	Function
	1	BI_DA+	Bi-directional pair +A
	2	BI_DA-	Bi-directional pair -A
	3	BI_DB+	Bi-directional pair +B
	4	BI_DC+	Bi-directional pair +C, PoE Positive
	5	BI_DC-	Bi-directional pair -C, PoE Positive
	6	BI_DB-	Bi-directional pair -B
	7	BI_DD+	Bi-directional pair +D, PoE Negative
	8	BI_DD-	Bi-directional pair -D, PoE Negative

Figure 6 AP211H Side View

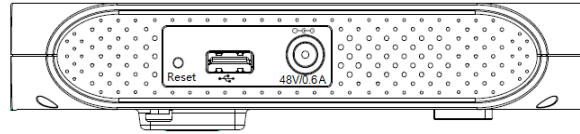

#### USB Interface

The AP211H access point is equipped with a USB 2.0 interface (Type A). When active, the USB port can supply up to 5V/0.5A power to an attached device.

#### Reset button

Factory reset. Press reset button for 5s, AP LEDs will quickly flash for 3s, then AP will restart and restore factory configurations.

#### Power

The AP211H access point supports direct DC power adapter (48V DC nominal, sold separately) and Power over Ethernet (PoE).

The DC power connector port is located on the side of the device, as shown in Figure 6.

*When both power sources are available, DC power takes priority over PoE. AP211H supports the power adapter provided by HAN ONLY.*

The PoE-in allows the Eth0 port to draw power from an 802.3at (preferred) source, or an 802.3af (optional) source.

When powered by an 802.3at or DC power source, the PoE-out (PoE-PSE) functionality could be enabled on port Eth3/PSE.

### Before You Begin

Refer to the sections below before beginning the installation process.

#### Pre-Installation Checklist

Before installing your AP211H access point, be sure that you have the following items:

- Gigabit Ethernet cable of required length, CAT5 or CAT6 is preferred.
- One of the following power sources:
  - IEEE 802.3af/at compliant Power over Ethernet (PoE) source.
  - HAN AC-DC adapter (sold separately), Output voltage DC 48V, output current  $\geq 0.6A$  is recommended.
- A PC terminal or a notebook

#### Identifying Specific Installation Locations

The AP211H access point must be secured to an HAN-approved wall or to a desk mount kit (sold separately).

The installation position should be as close as possible to the center of the required coverage area and should be free from obstructions or obvious sources of interference.

- Minimize the number of obstructions (such as walls) between the AP and user terminals.
- Electronic equipment or devices (such as microwave ovens) which may produce radio frequency noise should be away from the installation position of the AP.

*It is strictly prohibited to install around stagnant water, water seepage, leakage or condensation. Avoid cable condensation or water seepage along the cables connecting to the AP.*

### Installing the Access Point

The AP211H can be mounted into a single-gang wall-box with shipped mounting plate.

#### Use the steps below to install your AP211H.

1. Begin by removing the existing data wall plate (if applicable).
2. Make sure that there is an uplink Ethernet cable with RJ-45 plug in the wall-box. If not, please crimp an RJ-45 plug (not supplied) on the Ethernet cable.
3. Align the mounting holes of the AP211H mounting plate with mounting holes in your gang box, as shown in Figure 7 and Figure 8. For worldwide single gang outlet box, the mounting plate has two sets of mounting holes to meet the individual installation position requirement.

Figure 7 Mounting Plate to Gang Box(1)

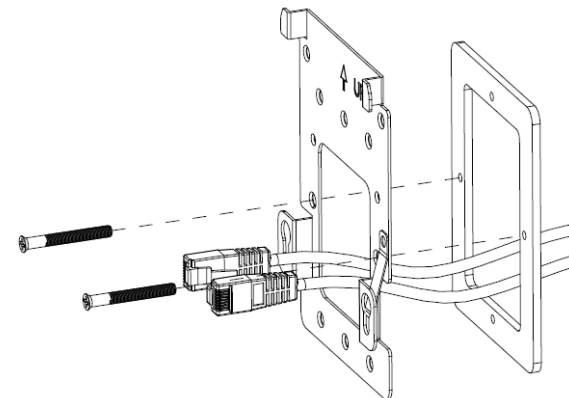
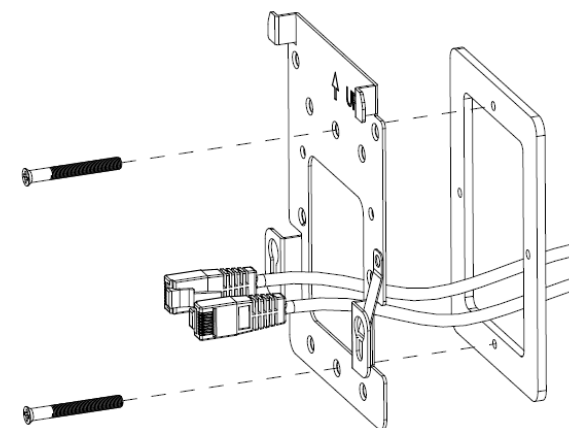

Figure 8 Mounting Plate to Gang Box (2)



4. Insert the two included slotted screws (or the two M4 screws, according to onsite requirement ) and tighten them to secure the mounting plate.

5. Connect the uplink Ethernet cable to the Eth0 port on the back of the AP211H. Do the same for the PT port, if used.

6. Align the mounting slots on the back of the AP211H with the corresponding mounting posts on the wall mounting plate as shown in Figure 9.

7. Push the access point against the posts and downward until the posts engage the slots at the top of the slots.

Figure 9 Attaching AP211H to wall mounting plate

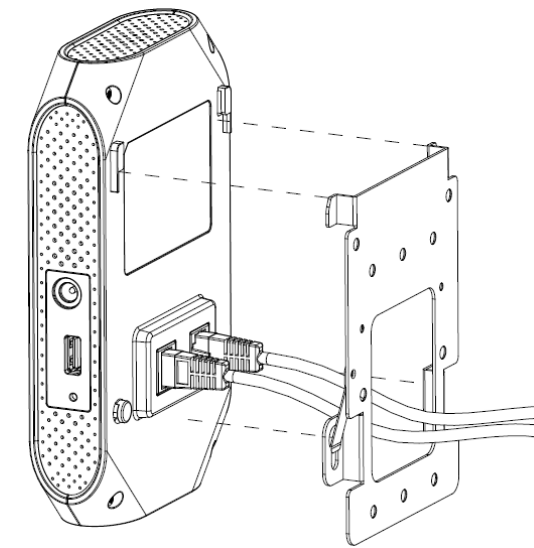

#### Verifying Post-Installation Connectivity

The integrated LED on the access point can be used to verify that the AP is receiving power and initializing successfully.

### Product Specifications

#### Dimensions/Weight

- Single AP excluding packing box and accessories:
  - 95 mm (W) x 34.45 mm (D) x 161.5 mm (H)
  - 3.74" (W) x 1.35" (D) x 6.35" (H)
  - 237g/0.522lb
- Single AP including packing box and accessories:
  - 115 mm (W) x 54 mm (D) x 182 mm (H)
  - 4.52" (W) x 2.13" (D) x 7.17"(H)
  - 417g/0.919lb

#### Power

- Supports direct DC power and Power over Ethernet (PoE)
- Power over Ethernet (PoE): 48 V DC (nominal) IEEE 802.3af/ 802.3at compliant source
- Maximum power consumption with PSE function and USB load: 25.5W

#### Environmental

- Operating :
  - Temperature: 0°C to +45°C (+32°F to +113°F)
  - Humidity: 5% to 95% non-condensing
- Storage and transportation :
  - Temperature: -40°C to +70°C (-40°F to +158°F)

For additional specifications on this product, please refer to the Datasheet.