

nMode™ Wireless Sensor Module

DATA SHEET

OSM-1-1313

Description:

Samtec's nMode™ Wireless Sensor Module enables remote sensing and measurement of inertial, environmental, and acoustical parameters. Leveraging standard ICs and compatibility with ST Microelectronics' STM32 ecosystem, Samtec's pre-engineered modules integrate industry standard, fully tested and certified wireless (Bluetooth® low energy technology), microcontroller and sensor components.

The modular design affords easy, functional customization during design and development and significantly reduces time to market for production.

Applications:

- Wearables
- Gaming Accessories
- Smart Homes
- Smart Agriculture
- Smart Industry
- Environmental Sensing
- Free-Fall Detection
- Internet of Things
- Security Detection
- Proximity Detection

Features:

- Highly integrated sensor platform

- Free fall /pedometer/tilt/single & double tap detection
- Compact size: 13.5 mm x 13.5 mm
- Single +3.6 V Supply (1.9 to 5.5V range) input
- Regulated 1.8 V output for external sensors
- Integrated 32 kHz & 32 MHz oscillators
- Multiple industry-standard serial interfaces
- Voice recognition using integrated microphone
- Bluetooth® low energy technology
- Onboard antenna included
- Full link controller and host security
- Compliant with radio frequency regulations:

- ETSI EN 300 328
- EN 300 440
- FCC CFR47 Part 15
- ARIB STD-T66



OSM-1-1313 Functional Block Diagram

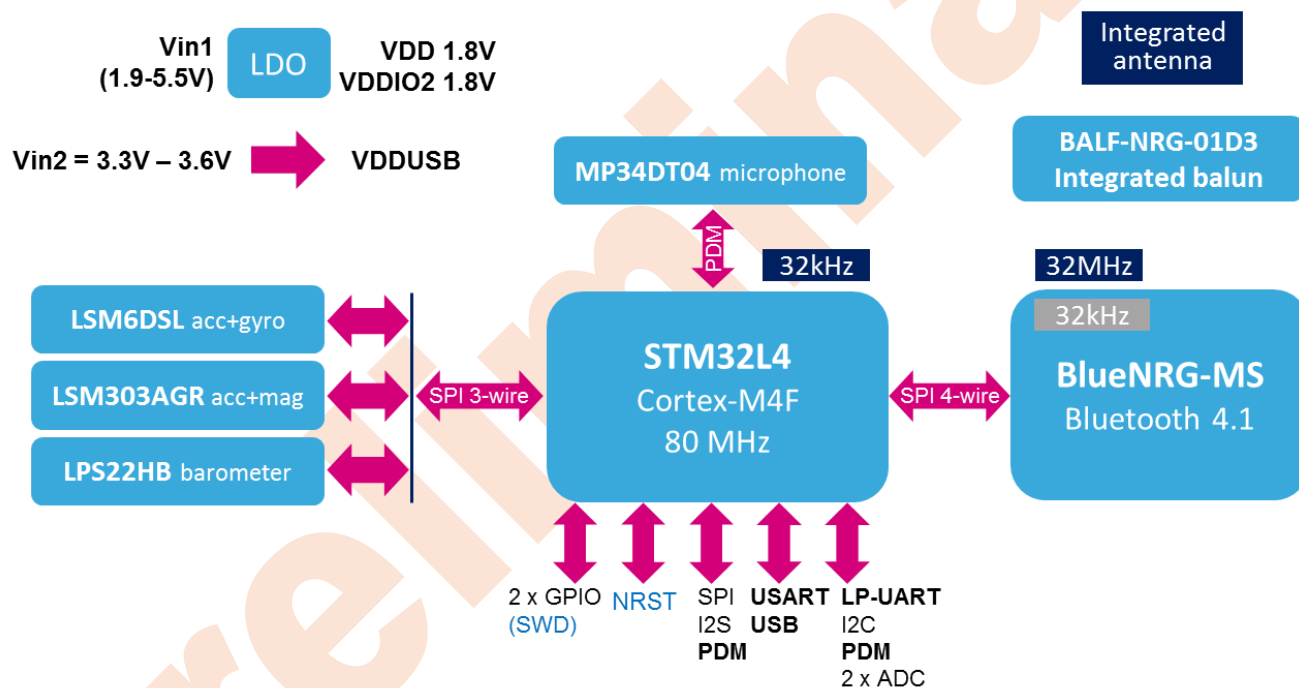

Figure 1 - OSM-1-1313 Functional Block Diagram



TABLE OF CONTENTS

Description..... 1
Applications..... 1
Features..... 1
Functional Block Diagram..... 2
Table of Contents..... 3
Detailed Descriptions..... 4
Pinout and Pin Descriptions..... 7
Power Supply Block Diagrams..... 8
Application Notes..... 9
Mechanical Dimensions.....10
Device Markings 10
Contact Samte nMode™ 11

Preliminary



OSM-1-1313 Detailed Description

The Samtec nMode™ Wireless Sensor Module is a highly-integrated reference design that can be plugged into form-factor prototypes and adds sensing and connectivity capabilities to new designs through a smart hub solution. It can also easily support development of monitoring and tracking applications as standalone sensor node connected to iOS/Android smartphone applications.

The nMode™ Wireless Sensor Module comes in a small 13.5 x 13.5 mm package. All the electronic components are on the top side of the PCB, while the bottom side has 19 PCB pads that render the nMode™ Wireless Sensor Module a surface mount solderable system for custom applications.

The module can be loaded with the BLUEMICROSYSTEM2 software that initializes all the sensors and the Bluetooth low energy radio. The “ST BlueMS” app, available free of charge on Apple Store™ and Google Play™, is the easiest and fastest way to start using the nMode™ Wireless Sensor Module board and to experience a real activity monitoring system.

The nMode™ Wireless Sensor Module firmware package, built on the STM32Cube software technology, includes all the low-level drivers to manage the on-board devices and system level interfaces. It has been designed in order to be easily extended and personalized as starting point for development and customization of new dedicated applications.

All the firmware packages are freely available on www.samtec.com.

Microcontroller

- STM32L476 Ultra-low-power with FPU ARM® Cortex®-M4 MCU
- Memory
 - 512 kB Flash, 2 banks read-while-write, proprietary code readout protection
 - 128 KB SRAM including 32 KB with hardware parity check
- External interfaces
 - UART
 - SPI
 - SAI (Serial Audio Interface)
 - I²C
 - DFSDM
 - USB OTG
 - ADC
 - GPIOs
- Ultra-low-power
 - Down to 30 nA for I/O wake-up
- Development support
 - Serial wire debug (SWD)
 - JTAG
 - Embedded Trace Macrocell™



Sensors

- LSM6DSL 3D Accelerometer + 3D Gyroscope:
 - Angular rate: ± 125 / ± 245 / ± 500 / ± 1000 / ± 2000 dps full scale
 - Acceleration: ± 2 / ± 4 / ± 8 / ± 16 g full scale
- LSM303AGR 3D Magnetometer + 3D Accelerometer:
 - Magnetic field: ± 50 gauss dynamic range
 - Acceleration: ± 2 / ± 4 / ± 8 / ± 16 g selectable full scale
- LPS22HB water & dust resistant pressure sensor / barometer:
 - Pressure: 260-1260 hPa absolute
- MP34DT04 Digital MEMS Microphone:
 - 64 dB SNR and -26 dBFS sensitivity

Wireless

- BlueNRG-MS Bluetooth® low energy network processor supporting Bluetooth® 4.1 core specification
- Embedded Bluetooth® low energy protocol stack
 - GAP
 - GATT
 - SM
 - L2CAP
 - LL
 - RF-PHY
- Integrated antenna enables 70+ foot range
- BALF-NRG-01D3 Integrated Balun Filter
- Compliant with radio frequency regulations:
 - ETSI EN 300 328
 - EN 300 440
 - FCC CFR47 Part 15,
 - ARIB STD-T66

Power

- Input voltage range
 - 1.9 V - 5.5 V
- Operating current
 - 20 uA standby
 - 8.5 mA typical
- LD39115J18R low quiescent, low current, low noise LDO for external sensors
- Maximum current for external sensors
 - 20 mA



System Level Support

- Very compact module for motion, audio and environmental sensing and Bluetooth low energy connectivity with a complete set of firmware examples
- Supported by the BLUEMICROSYSTEM1 and BLUEMICROSYSTEM2 software expansion package for STM32Cube and the STM32 ODE functional pack FP-SNSALLMEMS1 from STMicroelectronics.
- Mobile connectivity via the ST BlueMS app, available for iOS and Android
- Solderable surface mount interface
- SWD interface for debugging and programming capability

Preliminary



OSM-1-1313 Pinout and Pin Descriptions



Figure 3 - OSM-1-1313 Top View

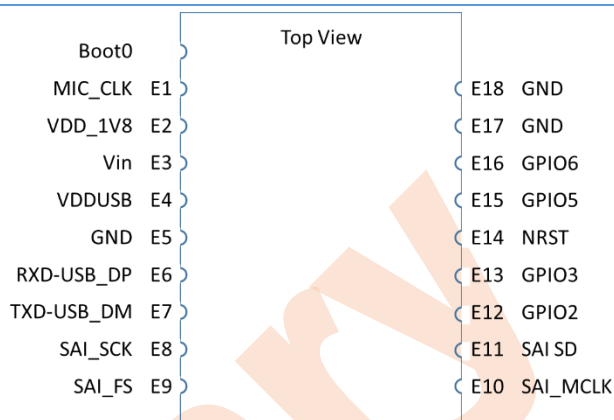

Figure 2 - OSM-1-1313 Pinout

Pin #	Name	Description
E0	Boot0	Logic high activates the boot loader – sampled at reset (see programming section)
E1	MIC_CLK	
E2	VDD_1V8	1.8 V regulated output for powering external sensors
E3	Vin	Input voltage with a 1.9 to 5.5 volt range
E4	VDDUSB	Input voltage form – apply 3.3 volts to enable the processor USB functionality otherwise ground this pin for best UART operation
E5	GND	Common ground connection for module – should be connected to common ground on circuit card
E6	RXD-USB_DP	Can be configured as USART Rx or USB_DP
E7	TXD-USB_DM	Can be configured as USART Tx or USB_DM
E8	SAI_SCK	Can be configured as SPI3_SCK or Serial Audio Interface SAI2_SCK_A
E9	SAI_FS	Can be configured as SPI3_MISO or Serial Audio Interface SAI2_FS_A
E10	SAI_MCLK	Can be configured as SPI3_MOSI or Serial Audio Interface SAI2_MCLK_A
E11	SAI_SD	Can be configured as SPI3_NSS or Serial Audio Interface SAI2_SD_A
E12	GPIO2	User definable general purpose input/output (LP_UART_TX, I2C3_SDA, ADC_IN2, DFSDM_CKIN4 [DFSDM_DATIN6])
E13	GPIO3	User definable general purpose input/output (LP_UART_RX, I2C3_SCL, ADC_IN1, DFSDM_DATIN4)
E14	NRST	SWD_RST or main processor reset line – a logic low (GND) resets the processor
E15	GPIO5	SWD_CLK or user definable general purpose input/output
E16	GPIO6	SWD_IO or user definable general purpose input/output
E17	GND	SWD_GND or common ground connection for module – should be connected to common ground on circuit card
E18	GND	Common ground connection for module – should be connected to common ground on circuit card

Figure 4 - OSM-1-1313 Pin Descriptions



Power Supply Block Diagrams

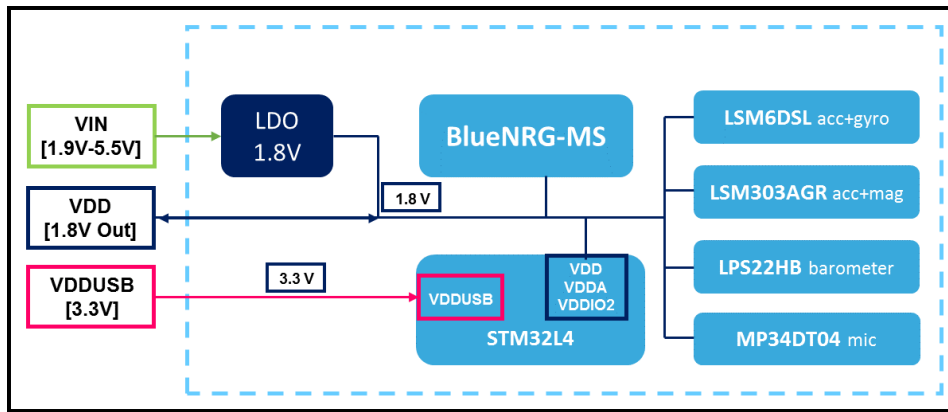

Figure 5 - USB Operation with VDD as Output

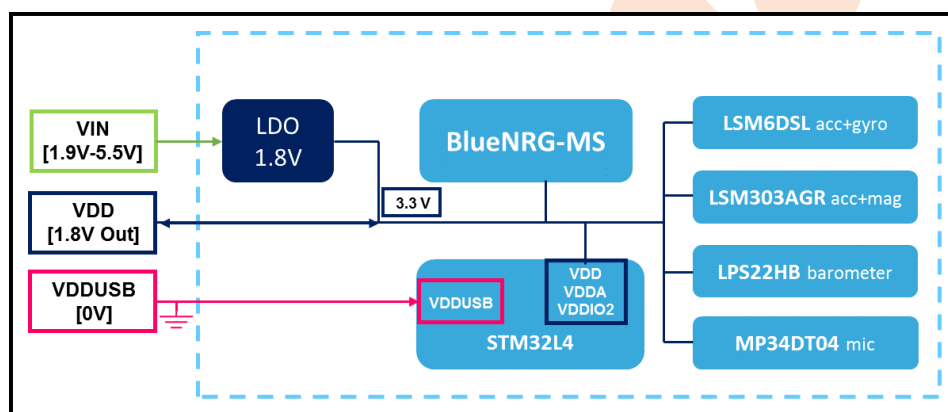

Figure 6 - UART Operations with VDD Pin as Output



ELECTRICAL SPECIFICATIONS**Absolute Maximum Ratings**

Symbol	Description	Min	Max	Unit	
VCC	Digital Input Value	1.9	5.5	V	
	Voltage on any digital pin	Digital I/O	-0.3	4	V

Recommended Operating Conditions

Test conditions: Ambient Temp = 25°C

Symbol	Min	Typ	Max	Unit
VCC	1.9	3.3	3.6	V
ICC (BLE Tx -2dBm MCU 80Mhz)*	-	30	-	mA
ICC (BLE Active MCU 80Mhz)*	-	18	-	mA
ICC (BLE Active MCU 20Mhz)*	-	8	-	mA
ICC (Standby)	-	20	-	uA

*Mag & Mag Accel at 100 Hz Output Data Rate (ODR); Gyro & Gyro Accel at 208 ODR

General Characteristics

Characteristic	Description
Model Name	nMode™ Wireless Sensor Module
Product Description	Bluetooth Low Energy Wireless Module
Dimension	13.5mm x 13.5mm 2.44 mm (W*L*T)
Operating Temperature	0°C to 70°C
Storage Temperature	-40°C to 85°C
Humidity	Operating Humidity 10% to 95% Non-Condensing Storage Humidity 5% to 95% Non-Condensing
Weight	0.68g +/- 0.009g



MODULE OUTPUT CONFIGURATION (Minimal)

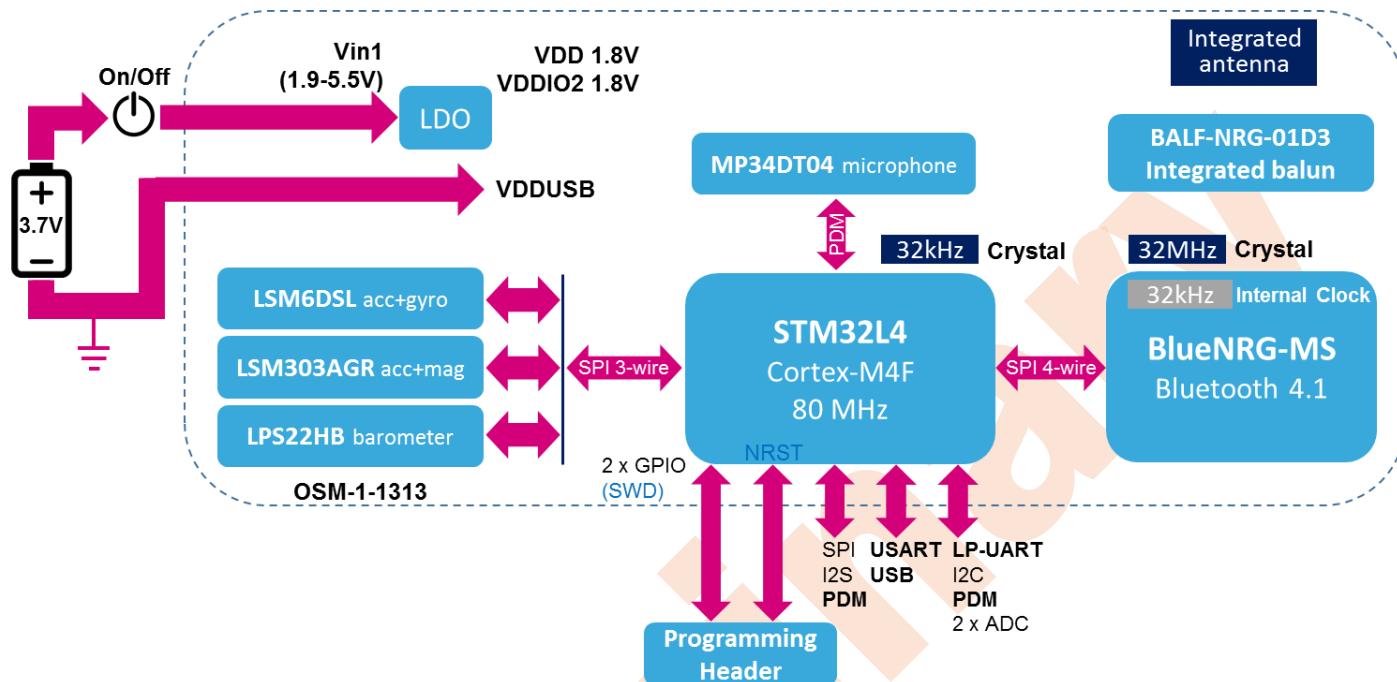

Figure 7 – Minimal Connections to Operate Module

SOLDERING RECOMMENDATIONS

Recommended Reflow Profile for Lead Free Solder

Do we need to add anything here? David Decker is working this

CLEANING

In general, cleaning the populated modules is strongly discouraged. Residuals under the module cannot be easily removed with any cleaning process.

- Cleaning with water can lead to capillary effects where water is absorbed into the gap between the host board and the module. The combination of soldering flux residuals and encapsulated water could lead to short circuits between neighboring pads. Water could also damage any stickers or labels.
- Cleaning with alcohol or a similar organic solvent will likely flood soldering flux residuals into the RF shield, which is not accessible for post-washing inspection. The solvent could also damage any stickers or labels.
- Ultrasonic cleaning could damage the module permanently.



OPTICAL INSPECTION

After soldering the Module to the host board, consider optical inspection to check the following:

- Proper alignment and centering of the module over the pads.
- Proper solder joints on all pads.
- Excessive solder or contacts to neighboring pads, or vias.

REWORK

The module can be unsoldered from the host board if the Moisture Sensitivity Level (MSL) requirements are met as described in this datasheet.

NOTE: Never attempt a rework on the module itself, e.g. replacing individual components. Such actions will terminate warranty coverage.

Preliminary



SHIPPING

Bulk orders of the Samtec nMode™ Wireless Sensor Module are delivered in reels of xxxx.

HANDLING

The Samtec nMode™ Wireless Sensor Module contains highly sensitive electronic circuitry. Handling without proper ESD protection may damage the module permanently.

MOISTURE SENSITIVITY LEVEL (MSL)

Per J-STD-020, devices rated as MSL 4 and not stored in a sealed bag with desiccant pack should be baked prior to use.

Devices are packaged in a Moisture Barrier Bag with a desiccant pack and Humidity Indicator Card (HIC). Devices that will be subjected to reflow should reference the HIC and J-STD-033 to determine if baking is required.

If baking is required, refer to J-STD-033 for bake procedure.

Storage

Per J-STD-033, the shelf life of devices in a Moisture Barrier Bag is 12 months at <40°C and <90% room humidity (RH).

Do not store in salty air or in an environment with a high concentration of corrosive gas, such as Cl₂, H₂S, NH₃, SO₂, or NO_x.

Do not store in direct sunlight.

The product should not be subject to excessive mechanical shock.

REPEATING REFLOW SOLDERING

Only a single reflow process is encouraged for host boards.

FCC Label



Wireless Sensor Module
FCC ID: 2ALII-OSM-1-1313
IC: 22500-OSM11313
Model: OSM-1-1313



Agency Certifications

Compliant with the following Federal Communications Commission(FCC) standards:

- FCC Part 15B (15.107 & 15.109)
- FCC Part 15C (15.203, 15.205, 15.207, 15.209 & 15.247)

Compliant with the following Industry Canada (IC) standards:

- ICES-003
- RSS-102
- RSS-247

Compliant with the following European Union (CE) standards:

- ETSI EN 300 328
- ETSI EN 301 489-1
- ETSI EN 301 489-17

Agency Statements

FCC Interference Statement

This equipment has been tested and found to comply with the limits for a Class B digital device, pursuant to Part 15 of the FCC Rules. These limits are designed to provide reasonable protection against harmful interference in a residential installation. This equipment generates uses and can radiate radio frequency energy and, if not installed and used in accordance with the instructions, may cause harmful interference to radio communications. However, there is no guarantee that interference will not occur in a particular installation. If this equipment does cause harmful interference to radio or television reception, which can be determined by turning the equipment off and on, the user is encouraged to try to correct the interference by one of the following measures:

- Reorient or relocate the receiving antenna.
- Increase the separation between the equipment and receiver.
- Connect the equipment into an outlet on a circuit different from that to which the receiver is connected.
- Consult the dealer or an experienced radio/TV technician for help.

This device complies with Part 15 of the FCC Rules. Operation is subject to the following two conditions: (1) This device may not cause harmful interference, and (2) this device must accept any interference received, including interference that may cause undesired operation.

This portable transmitter with its antenna complies with FCC/IC RF exposure limits for general population /uncontrolled exposure.

FCC CAUTION: Any changes or modifications not expressly approved by the party responsible for compliance could void the user's authority to operate this equipment.



Industry Canada Statements

This device complies with Industry Canada License-exempt RSS standard(s). Operation is subject to the following two conditions: (1) this device may not cause interference, and (2) this device must accept any interference, including interference that may cause undesired operation of the device.

To reduce potential radio interference to other users, the antenna type and its gain should be so chosen that the equivalent isotropically radiated power (e.i.r.p.) is not more than that permitted for successful communication.

This device has been designed to operate with the antenna(s) listed below, and having a maximum gain of 0 dBi (PCB Trace). Antennas not included in this list or having a gain greater than 0 dB are strictly prohibited for use with this device. The required antenna impedance is 50 ohms.

List of all Antennas Acceptable for use with the Transmitter

- TDK ANT016008LCS2442MA1 2400-2484MHz Multilayer Antenna

Cet appareil est conforme aux normes d'Industrie Canada exempts de licence RSS (s). L'opération est soumise aux deux conditions suivantes: (1) cet appareil ne peut pas provoquer d'interférences et (2) cet appareil doit accepter toute interférence, y compris les interférences qui peuvent causer un mauvais fonctionnement de l'appareil.

Pour réduire le risque d'interférence aux autres utilisateurs, le type d'antenne et son gain doivent être choisis de manière que la puissance isotrope rayonnée équivalente (PIRE) ne dépasse pas celle permise pour une communication réussie.

Cet appareil a été conçu pour fonctionner avec l'antenne (s) ci-dessous, et ayant un gain maximum de 0 dBi (PCB Trace). Antennes pas inclus dans cette liste ou présentant un gain supérieur à 0 dBi sont strictement interdite pour une utilisation avec cet appareil. L'impédance d'antenne requise est de 50 ohms.

Liste de toutes les antennes acceptables pour utilisation avec l'émetteur

- TDK ANT016008LCS2442MA1 antenne multicouche 2,400-2,484 MHz



IC RSS-102 Compliance Statement

This system has been evaluated for RF Exposure per RSS-102 and is in compliance with the limits specified by Health Canada Safety Code 6. The system must be installed at a minimum separation distance from the antenna to a general bystander of 7.9 inches (20 cm) to maintain compliance with the General Population limits.

L'exposition aux radiofréquences de ce système a été évaluée selon la norme RSS-102 et est jugée conforme aux limites établies par le Code de sécurité 6 de Santé Canada. Le système doit être installé à une distance minimale de 7.9 pouces (20 cm) séparant l'antenne d'une personne présente en conformité avec les limites permises d'exposition du grand public.

IC RSS-Gen 8.4 Compliance Statement

This device complies with Industry Canada license-exempt RSS standard(s). Operation is subject to the following two conditions: (1) this device may not cause interference, and (2) this device must accept any interference, including interference that may cause undesired operation of the device.

Le présent appareil est conforme aux CNR d'Industrie Canada applicables aux appareils radio exempts de licence. L'exploitation est autorisée aux deux conditions suivantes : (1) l'appareil ne doit pas produire de brouillage, et (2) l'utilisateur de l'appareil doit accepter tout brouillage radioélectrique subi, même si le brouillage est susceptible d'en compromettre le fonctionnement.



OEM RESPONSIBILITIES TO COMPLY WITH FCC AND INDUSTRY CANADA REGULATIONS

The nMode™ Wireless Sensor Module has been certified for integration into products only by OEM integrators under the following conditions:

The antennas for this transmitter must not be co-located with any other transmitters except in accordance with FCC and Industry Canada multi-transmitter procedures. Co-location means having a separation distance of less than 20 cm between transmitting antennas.

As long as the two conditions above are met, further transmitter testing will not be required. However, the OEM integrator is still responsible for testing their end-product for any additional compliance requirements required with this module installed (for example, digital device emissions, PC peripheral requirements, etc.).

IMPORTANT NOTE: In the event that these conditions cannot be met (for certain configurations or colocation with another transmitter), then the FCC and Industry Canada authorizations are no longer considered valid and the FCC ID and IC Certification Number cannot be used on the final product. In these circumstances, the OEM integrator will be responsible for re-evaluating the end product (including the transmitter) and obtaining a separate FCC and Industry Canada authorization.

Le module de nMode™ Wireless Sensor Module été certifié pour l'intégration dans des produits uniquement par des intégrateurs OEM dans les conditions suivantes:

Les antennes pour ce transmetteur ne doit pas être co-localisés avec les autres émetteurs sauf en conformité avec la FCC et Industrie Canada multi-émetteur procédures. Co-localisation des moyens ayant une distance de séparation inférieure à 20 cm entre les antennes d'émission.

Tant que les deux conditions précitées sont réunies, les tests de transmetteurs supplémentaires ne seront pas tenus. Toutefois, l'intégrateur OEM est toujours responsable de tester leur produit final pour toutes les exigences de conformité supplémentaires requis avec ce module installé (par exemple, les émissions appareil numérique, les exigences de périphériques PC, etc.)

NOTE IMPORTANTE: Dans le cas où ces conditions ne peuvent être satisfaites (pour certaines configurations ou de co-implantation avec un autre émetteur), puis la FCC et Industrie autorisations Canada ne sont plus considérés comme valides et l'ID de la FCC et IC numéro de certification ne peut pas être utilisé sur la produit final. Dans ces circonstances, l'intégrateur OEM sera chargé de réévaluerle produit final (y compris l'émetteur) et l'obtention d'un distincte de la FCC et Industrie Canada l'autorisation.



OEM LABELING REQUIREMENTS FOR END-PRODUCT

The nMode™ Wireless Sensor Module is labeled with its own FCC ID and IC Certification Number. The FCC ID and IC certification numbers are not visible when the module is installed inside another device, as such the end device into which the module is installed must display a label referring to the enclosed module. The final end product must be labeled in a visible area with the following:

“Contains Transmitter Module FCC ID: 2ALII - OSM-1-1313”

“Contains Transmitter Module IC ID: 22500 – OSM11313”

or

“Contains FCC ID: 2ALII - OSM-1-1313”

“Contains IC ID : 22500 – OSM11313”

The OEM of the nMode™ Wireless Sensor Module must only use the approved antenna(s) listed above, which have been certified with this module.

Le module de nMode™ Wireless Sensor Module est étiqueté avec son propre ID de la FCC et IC numéro de certification. L'ID de la FCC et IC numéros de certification ne sont pas visibles lorsque le module est installé à l'intérieur d'un autre appareil, comme par exemple le terminal dans lequel le module est installé doit afficher une étiquette faisant référence au module ci-joint. Le produit final doit être étiqueté dans un endroit visible par le suivant:

“Contient Module émetteur FCC ID: 2ALII - OSM-1-1313”

“Contient Module émetteur IC ID: 22500 – OSM11313”

ou

“Contient FCC ID: 2ALII - OSM-1-1313”

“Contient IC ID: 22500 – OSM11313”

Les OEM du module nMode™ Wireless Sensor Module ne doit utiliser l'antenne approuvée (s) ci-dessus, qui ont été certifiés avec ce module.



OEM END PRODUCT USER MANUAL STATEMENTS

The OEM integrator should not provide information to the end user regarding how to install or remove this RF module or change RF related parameters in the user manual of the end product.

Other user manual statements may apply.

EUROPE

CE Notice

This device has been tested and certified for use in the European Union. See the Declaration of Conformity (DOC) for specifics.

If this device is used in a product, the OEM has responsibility to verify compliance of the final product to the EU standards. A Declaration of Conformity must be issued and kept on file as described in the Radio and Telecommunications Terminal Equipment (R&TTE) Directive.

The 'CE' mark must be placed on the OEM product per the labeling requirements of the Directive.

Declaration of Conformity (DOC)

The DOC is available from Samtec.

BLUETOOTH CERTIFICATION

The nMode™ Wireless Sensor Module enables module has been certified as a Component (Tested) and has a QDID of XXXXX



Application Notes

Bluetooth Antenna

There is a required ground clearance area, indicated on the module package dimensions page, where all metallization should be removed from all PWB layers. This ground clearance area will ensure proper operation of the embedded antenna.

NOTE: We need the following:

[PCB Trace Antenna Pattern Measurement Planes](#)

[PCB Trace Antenna Gain Summary](#)

[PCB Trace Antenna Patterns](#)

Programming

Our smart module microprocessor comes pre-loaded with software which enables the user to evaluate the module mounted onto the smart module evaluation board. This preloaded software makes full use of the onboard Bluetooth low energy, accelerometer/gyroscope, and magnetometer. Our provided Windows OS application will show how to obtain values from each sensor as well as how to establish a Bluetooth connection. In addition, users may explore other options in the smart module software stack which enables another smart module to be used in order to create an instant ad-hoc (P2P) meshing connection. This will allow for evaluation of the smart modules [simultaneous master/slave capability]. The smart module microprocessor comes pre-programmed with default software that allows you to connect up to the GUI and interface wirelessly through the embedded low energy Bluetooth network immediately.

[Need more detail here. Do we have screen captures of the system GUI?](#)



Mechanical Dimensions

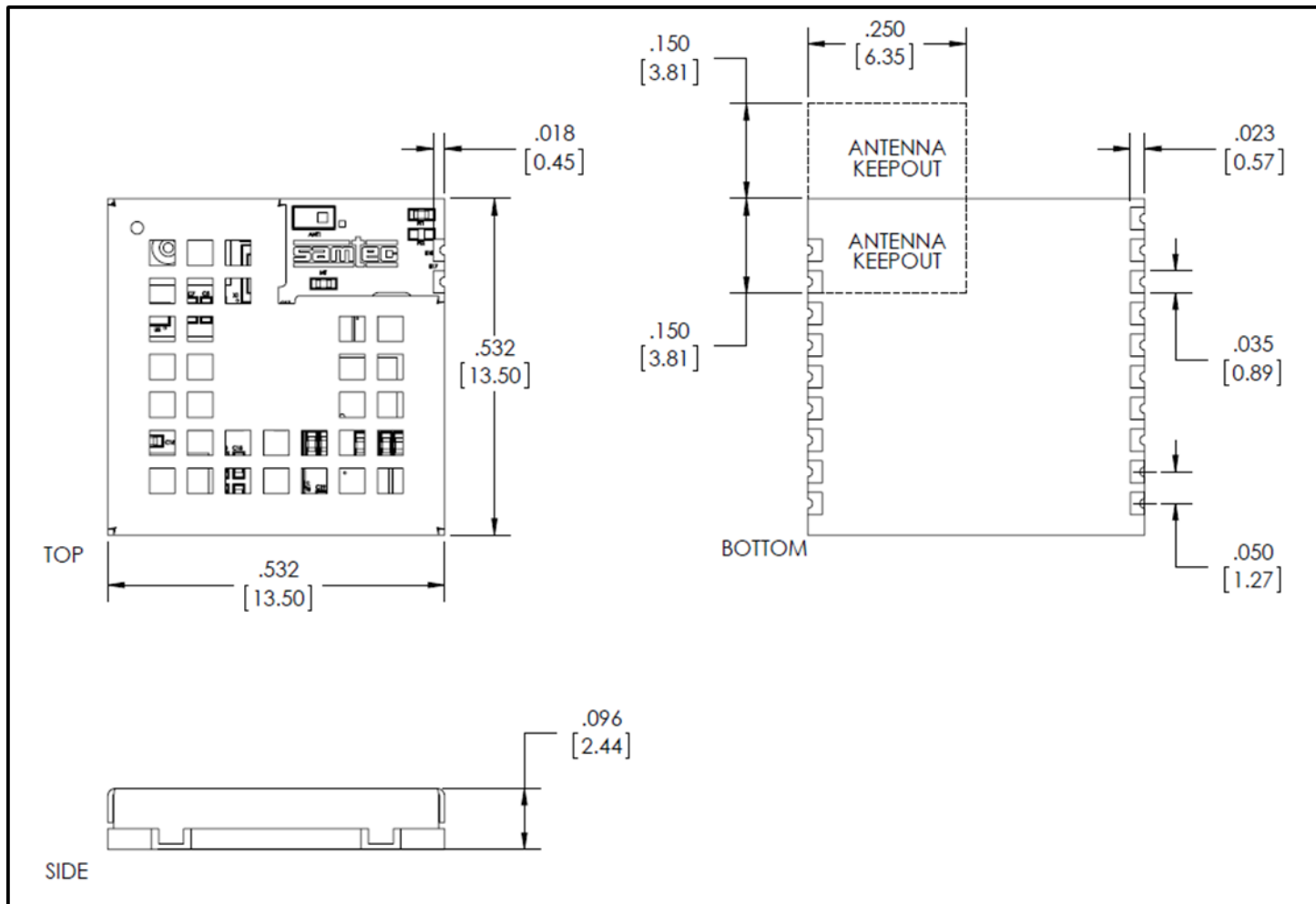

Figure 8 - OSM-1-1313 Mechanical Dimensions

Device Markings (Not sure about marking yet - JB)

YYWW – Date Code 2 Digit Year and Week

XXXX – Part Number



Contact Samtec nMode™

Website

www.samtec.com/modules

E-mail

SamrtModules@samtec.com

Preliminary

