

## FCC Test Report

**Report No.:** RF180710E01

**FCC ID:** 2ALI9V-VJETM2

**Test Model:** V-JETm2

**Received Date:** July 10, 2018

**Test Date:** Aug. 27 to 31, 2018

**Issued Date:** Sep. 21, 2018

**Applicant:** WISEJET, INC.

**Address:** 401, IT Venture Town, 35, Techno 9-ro, Yuseong-gu, Daejun, South Korea

**Issued By:** Bureau Veritas Consumer Products Services (H.K.) Ltd., Taoyuan Branch  
Hsin Chu Laboratory

**Lab Address:** E-2, No.1, Li Hsin 1st Road, Hsinchu Science Park, Hsinchu City 300,  
Taiwan R.O.C.

**Test Location:** E-2, No.1, Li Hsin 1st Road, Hsinchu Science Park, Hsinchu City 300,  
Taiwan R.O.C.

**FCC Registration /  
Designation Number:** 723255 / TW2022



This report is for your exclusive use. Any copying or replication of this report to or for any other person or entity, or use of our name or trademark, is permitted only with our prior written permission. This report sets forth our findings solely with respect to the test samples identified herein. The results set forth in this report are not indicative or representative of the quality or characteristics of the lot from which a test sample was taken or any similar or identical product unless specifically and expressly noted. Our report includes all of the tests requested by you and the results thereof based upon the information that you provided to us. You have 60 days from date of issuance of this report to notify us of any material error or omission caused by our negligence, provided, however, that such notice shall be in writing and shall specifically address the issue you wish to raise. A failure to raise such issue within the prescribed time shall constitute your unqualified acceptance of the completeness of this report, the tests conducted and the correctness of the report contents. Unless specific mention, the uncertainty of measurement has been explicitly taken into account to declare the compliance or non-compliance to the specification. The report must not be used by the client to claim product certification, approval, or endorsement by TAF or any government agencies.

## Table of Contents

<b>Release Control Record</b> .....	<b>4</b>
<b>1 Certificate of Conformity</b> .....	<b>5</b>
<b>2 Summary of Test Results</b> .....	<b>6</b>
2.1 Measurement Uncertainty .....	6
2.2 Modification Record .....	6
<b>3 General Information</b> .....	<b>7</b>
3.1 General Description of EUT .....	7
3.2 Description of Test Modes .....	8
3.2.1 Test Mode Applicability and Tested Channel Detail .....	9
3.3 Description of Support Units .....	11
3.3.1 Configuration of System under Test .....	12
3.4 General Description of Applied Standards .....	13
<b>4 Test Types and Results</b> .....	<b>14</b>
4.1 Radiated Emission Measurement .....	14
4.1.1 Limits of Radiated Emission Measurement .....	14
4.1.2 Test Instruments .....	15
4.1.3 Test Procedures .....	17
4.1.4 Deviation from Test Standard .....	18
4.1.5 Test Setup .....	19
4.1.6 EUT Operating Conditions .....	20
4.1.7 Test Results (LRP mode) .....	21
4.1.8 Test Results (HRP mode) .....	51
4.2 Conducted Emission Measurement .....	61
4.2.1 Limits of Conducted Emission Measurement .....	61
4.2.2 Test Instruments .....	61
4.2.3 Test Procedures .....	62
4.2.4 Deviation from Test Standard .....	62
4.2.5 Test Setup .....	62
4.2.6 EUT Operating Conditions .....	62
4.2.7 Test Results .....	63
4.3 6dB Bandwidth Measurement .....	65
4.3.1 Limits of 6dB Bandwidth Measurement .....	65
4.3.2 Test Setup .....	65
4.3.3 Test Instruments .....	65
4.3.4 Test Procedure .....	65
4.3.5 Deviation from Test Standard .....	65
4.3.6 EUT Operating Conditions .....	65
4.3.7 Test Result (LRP Mode) .....	66
4.3.8 Test Result (HRP Mode) .....	68
4.4 Output Power Measurement .....	69
4.4.1 Limits of Output Power Measurement .....	69
4.4.2 Test Setup .....	70
4.4.3 Test Instruments .....	70
4.4.4 Test Procedures .....	71
4.4.5 Deviation from Test Standard .....	71
4.4.6 EUT Operating Conditions .....	72
4.4.7 Test Results (LRP Mode) .....	72
4.4.8 Test Results (HRP Mode) .....	72
4.5 Frequency Stability Measurement .....	73
4.5.1 Limits of Frequency Stability Measurement .....	73
4.5.2 Test Setup .....	73
4.5.3 Test Instruments .....	73
4.5.4 Test Procedure .....	73

4.5.5 Deviation from Test Standard .....	73
4.5.6 EUT Operating Condition .....	73
4.5.7 Test Results .....	74
<b>5 Pictures of Test Arrangements .....</b>	<b>75</b>
<b>Appendix – Information on the Testing Laboratories .....</b>	<b>76</b>

### Release Control Record

Issue No.	Description	Date Issued
RF180710E01	Original release.	Sep. 21, 2018

## 1 Certificate of Conformity

**Product:** V-JET  
**Brand:** WISEJET  
**Test Model:** V-JETm2  
**Sample Status:** ENGINEERING SAMPLE  
**Applicant:** WISEJET, INC.  
**Test Date:** Aug. 27 to 31, 2018  
**Standards:** 47 CFR FCC Part 15, Subpart C (Section 15.255)  
ANSI C63.10: 2013

The above equipment has been tested by **Bureau Veritas Consumer Products Services (H.K.) Ltd., Taoyuan Branch**, and found compliance with the requirement of the above standards. The test record, data evaluation & Equipment Under Test (EUT) configurations represented herein are true and accurate accounts of the measurements of the sample's EMC characteristics under the conditions specified in this report.

**Prepared by :** Wendy Wu , **Date:** Sep. 21, 2018  
Wendy Wu / Specialist

**Approved by :** May Chen , **Date:** Sep. 21, 2018  
May Chen / Manager

## 2 Summary of Test Results

47 CFR FCC Part 15, Subpart C (Section 15.255)			
FCC Clause	Test Item	Result	Remarks
15.207	AC Power Conducted Emission	PASS	Meet the requirement of limit. Minimum passing margin is -13.24dB at 0.54356MHz.
15.255(e)	6dB Bandwidth	-	Reference only.
15.255 (c) & (e)	Output Power	PASS	Meet the requirement of limit.
15.255(d)	Spurious Emissions	PASS	Meet the requirement of limit. Minimum passing margin is -3.6dB at 891.26MHz.
15.255(f)	Frequency Stability	PASS	Meet the requirement of limit.

### 2.1 Measurement Uncertainty

Where relevant, the following measurement uncertainty levels have been estimated for tests performed on the EUT as specified in CISPR 16-4-2:

Measurement	Frequency	Expanded Uncertainty (k=2) ( $\pm$ )
Conducted Emissions at mains ports	150kHz ~ 30MHz	1.84 dB
Radiated Emissions up to 1 GHz	30MHz ~ 1GHz	5.53 dB
Radiated Emissions above 1 GHz	1GHz ~ 6GHz	5.08 dB
	6GHz ~ 18GHz	4.98 dB
	18GHz ~ 40GHz	5.19 dB

### 2.2 Modification Record

There were no modifications required for compliance.

### 3 General Information

#### 3.1 General Description of EUT

Product	V-JET
Brand	WISEJET
Test Model	V-JETm2
Status of EUT	ENGINEERING SAMPLE
Power Supply Rating	DC 5V from host equipment
Modulation Type	16QAM, QPSK, BPSK
Modulation Technology	OFDM
Transfer Rate	LRP-BPSK (20.337Mb/s) HRP-QPSK (0.952Gbs -Quarter Rate,1.904Gb/s-Half Rate) HRP-16QAM (3.807 Gb/s-Full Rate)
Operating Frequency	LRP: 60.16GHz ~ 62.96GHz HRP: 60.48GHz ~ 62.64GHz
Output Power	LRP: 10.48 dBm HRP: 12.11 dBm
Antenna Type	Refer to Note
Antenna Connector	NA
Accessory Device	NA
Data Cable Supplied	NA

Note:

1. The antenna provided to the EUT, please refer to the following table:

Brand	Model	Antenna Gain (dBi)	Frequency range	Antenna Type	Connector Type
Lattice Semiconductor	Sil6400	9	59.4~63.56GHz	dipole array antenna	none

2. The above EUT information is declared by manufacturer and for more detailed features description, please refer to the manufacturer's specifications or user's manual.

### 3.2 Description of Test Modes

LRP MODE							
Frequency Band	Channel Plan	Channel	Frequency	Channel	Frequency	Channel	Frequency
60.16 – 60.80GHz	A	1	60.16GHz	2	60.48GHz	3	60.80GHz
62.32 – 62.96GHz	B	1	62.32GHz	2	62.64GHz	3	62.96GHz

HRP MODE	
Channel	Frequency
1	60.48GHz
2	62.64GHz



### 3.2.1 Test Mode Applicability and Tested Channel Detail

EUT CONFIGURE MODE	APPLICABLE TO						DESCRIPTION
	PLC	BW	OP	FS	RE < 1G	RE ≥ 1G	
L	-	√	√	-	√	√	LRP Mode
H	√	√	√	√	√	√	HRP Mode

Where **PLC**: Power Line Conducted Emission      **BW**: 6dB Bandwidth  
**OP**: Output Power      **FS**: Frequency Stability  
**RE < 1G**: Radiated Emission below 1GHz      **RE ≥ 1G**: Radiated Emission above 1GHz

**NOTE:** The EUT had been pre-tested on the positioned of each 3 axis. The worst case was found when positioned on **X-plane**.

#### **Power Line Conducted Emission Test:**

- Pre-Scan has been conducted to determine the worst-case mode from all possible combinations between available modulations, data rates and antenna ports (if EUT with antenna diversity architecture).
- Following channel(s) was (were) selected for the final test as listed below.

EUT CONFIGURE MODE	AVAILABLE CHANNEL	TESTED CHANNEL	MODULATION TECHNOLOGY	MODULATION TYPE	DATA RATE (Mbps)
H	1	1	OFDM	QPSK	3.807Gb/s

#### **6dB Bandwidth Test:**

- Pre-Scan has been conducted to determine the worst-case mode from all possible combinations between available modulations, data rates and antenna ports (if EUT with antenna diversity architecture).
- Following channel(s) was (were) selected for the final test as listed below.

EUT CONFIGURE MODE	AVAILABLE CHANNEL	TESTED CHANNEL	MODULATION TECHNOLOGY	MODULATION TYPE	DATA RATE (Mbps)
L	3	1, 2, 3	OFDM	BPSK	20.337 Mb/s
H	1	1, 2	OFDM	QPSK	3.807Gb/s

### Frequency stability test:

- Pre-Scan has been conducted to determine the worst-case mode from all possible combinations between available modulations, data rates and antenna ports (if EUT with antenna diversity architecture).
- Following channel(s) was (were) selected for the final test as listed below.

EUT CONFIGURE MODE	AVAILABLE CHANNEL	TESTED CHANNEL	MODULATION TECHNOLOGY	MODULATION TYPE	DATA RATE (Mbps)
H	1	1	OFDM	QPSK	3.807Gb/s

### Radiated Emission Test (Below 1GHz):

- Pre-Scan has been conducted to determine the worst-case mode from all possible combinations between available modulations, data rates and antenna ports (if EUT with antenna diversity architecture).
- Following channel(s) was (were) selected for the final test as listed below.

EUT CONFIGURE MODE	AVAILABLE CHANNEL	TESTED CHANNEL	MODULATION TECHNOLOGY	MODULATION TYPE	DATA RATE (Mbps)
L	3	1, 2, 3	OFDM	BPSK	20.337 Mb/s
H	1	1, 2	OFDM	QPSK	3.807Gb/s

### Radiated Emission Test (Above 1GHz):

- Pre-Scan has been conducted to determine the worst-case mode from all possible combinations between available modulations, data rates and antenna ports (if EUT with antenna diversity architecture).
- Following channel(s) was (were) selected for the final test as listed below.

EUT CONFIGURE MODE	AVAILABLE CHANNEL	TESTED CHANNEL	MODULATION TECHNOLOGY	MODULATION TYPE	DATA RATE (Mbps)
L	3	1, 2, 3	OFDM	BPSK	20.337 Mb/s
H	1	1, 2	OFDM	QPSK	3.807Gb/s

### Test Condition:

APPLICABLE TO	ENVIRONMENTAL CONDITIONS	INPUT POWER	TESTED BY
RE≥1G	23deg. C, 68%RH 25deg. C, 60%RH	120Vac, 60Hz	Eason Tseng Weiwei Lo
RE<1G	25deg. C, 71%RH	120Vac, 60Hz	Andy Ho
PLC	24deg. C, 76%RH	120Vac, 60Hz	Andy Ho
APCM	25deg. C, 60%RH	120Vac, 60Hz	Weiwei Lo

### 3.3 Description of Support Units

The EUT has been tested as an independent unit together with other necessary accessories or support units. The following support units or accessories were used to form a representative test configuration during the tests.

ID	Product	Brand	Model No.	Serial No.	FCC ID	Remarks
A.	Mobile Phone	SAMSUNG	S8	NA	NA	Supplied by client
B.	Test Tool	NA	NA	NA	NA	Supplied by client
C.	USB Adapter	SAMSUNG	EP-TA300	NA	NA	Supplied by client
D.	Laptop	DELL	E6420	B92T3R1	FCC DoC	Provided by Lab
E.	Test Tool	NA	NA	NA	NA	Supplied by client
F.	RX Test Tool	NA	NA	NA	NA	Supplied by client
G.	USB Adapter	SAMSUNG	ETA-U90EWE	NA	NA	Supplied by client
H.	Monitor	DELL	P2415Q	CN-0J1P7F-QDC00-8 5L-13GB-A09	FCC DoC	Provided by Lab

Note:

1. All power cords of the above support units are non-shielded (1.8m).

ID	Descriptions	Qty.	Length (m)	Shielding (Yes/No)	Cores (Qty.)	Remarks
1.	USB Type-C Cable	1	0.7	Yes	0	Supplied by client
2.	USB Type-C Cable	1	1.5	Yes	0	Supplied by client
3.	microUSB Cable	1	1	Yes	0	Supplied by client
4.	Cable	1	0.9	No	0	Supplied by client
5.	microUSB Cable	1	1	Yes	0	Supplied by client
6.	HDMI Cable	1	1.5	Yes	2	Supplied by client

Note: The core(s) is(are) originally attached to the cable(s).

### 3.3.1 Configuration of System under Test

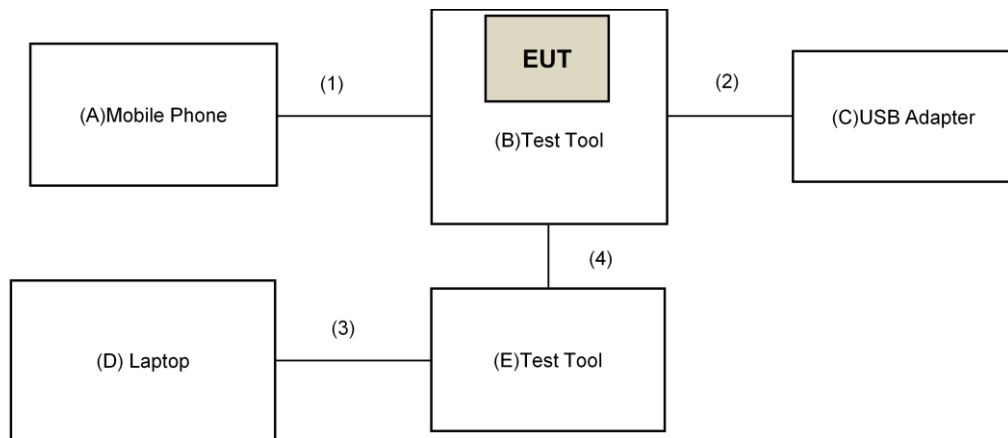

-----  
**Remote Site**

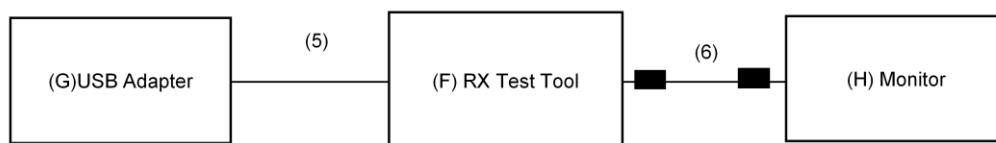

### **3.4 General Description of Applied Standards**

The EUT is a RF Product. According to the specifications of the manufacturer, it must comply with the requirements of the following standards:

**FCC Part 15, Subpart C (15.255)**

**ANSI C63.10-2013**

**FCC KDB 200443 D02 RF Detector Method v01**

All test items have been performed and recorded as per the above standards.

## 4 Test Types and Results

### 4.1 Radiated Emission Measurement

#### 4.1.1 Limits of Radiated Emission Measurement

Spurious Emission	
Frequency Range	Average
Radiated emissions below 40GHz	Part 15.209
Between 40GHz and 200GHz	90pW/cm <sup>2</sup> (at 3 meter)
Note: The levels of the spurious emissions shall not exceed the level of the fundamental emission	

Emissions radiated outside of the specified bands, shall be according to the general radiated limits in 15.209 as following:

Frequencies (MHz)	Field strength (microvolts/meter)	Measurement distance (meters)
0.009-0.490	2400/F(kHz)	300
0.490-1.705	24000/F(kHz)	30
1.705-30.0	30	30
30-88	100	3
88-216	150	3
216-960	200	3
Above 960	500	3

**NOTE:**

1. The lower limit shall apply at the transition frequencies.
2. Emission level (dBuV/m) = 20 log Emission level (uV/m).
3. As shown in 15.35(b), for frequencies above 1000MHz, the field strength limits are based on average detector, however, the peak field strength of any emission shall not exceed the maximum permitted average limits, specified above by more than 20dB under any condition of modulation.
4. Section 15.205 restricted bands of operation shall compliance with the limits in Section 15.209.

#### 4.1.2 Test Instruments

##### Below 40GHz test:

DESCRIPTION & MANUFACTURER	MODEL NO.	SERIAL NO.	CALIBRATED DATE	CALIBRATED UNTIL
Test Receiver Agilent	N9038A	MY50010156	July 12, 2018	July 11, 2019
Pre-Amplifier EMCI	EMC001340	980142	Feb. 09, 2018	Feb. 08, 2019
Loop Antenna(*) Electro-Metrics	EM-6879	264	Dec. 16, 2016	Dec. 15, 2018
RF Cable	NA	LOOPCAB-00 1	Jan. 15, 2018	Jan. 14, 2019
RF Cable	NA	LOOPCAB-00 2	Jan. 15, 2018	Jan. 14, 2019
Pre-Amplifier Mini-Circuits	ZFL-1000VH2 B	AMP-ZFL-05	May 05, 2018	May 04, 2019
Trilog Broadband Antenna SCHWARZBECK	VULB 9168	9168-361	Nov. 29, 2017	Nov. 28, 2018
RF Cable	8D	966-3-1	Mar. 20, 2018	Mar. 19, 2019
RF Cable	8D	966-3-2	Mar. 20, 2018	Mar. 19, 2019
RF Cable	8D	966-3-3	Mar. 20, 2018	Mar. 19, 2019
Fixed attenuator Mini-Circuits	UNAT-5+	PAD-3m-3-01	Oct. 03, 2017	Oct. 02, 2018
Horn_Antenna SCHWARZBECK	BBHA9120-D	9120D-406	Dec. 12, 2017	Dec. 11, 2018
Pre-Amplifier EMCI	EMC12630SE	980384	Jan. 29, 2018	Jan. 28, 2019
RF Cable	EMC104-SM- SM-1200	160922	Jan. 29, 2018	Jan. 28, 2019
RF Cable	EMC104-SM- SM-2000	150317	Jan. 29, 2018	Jan. 28, 2019
RF Cable	EMC104-SM- SM-5000	150322	Jan. 29, 2018	Jan. 28, 2019
Spectrum Analyzer Keysight	N9030A	MY54490679	July 23, 2018	July 22, 2019
Pre-Amplifier EMCI	EMC184045S E	980386	Jan. 29, 2018	Jan. 28, 2019
Horn_Antenna SCHWARZBECK	BBHA 9170	BBHA9170608	Dec. 14, 2017	Dec. 13, 2018
RF Cable	EMC102-KM- KM-1200	160924	Jan. 29, 2018	Jan. 28, 2019
Software	ADT_Radiated _V8.7.08	NA	NA	NA
Antenna Tower & Turn Table Max-Full	MF-7802	MF780208406	NA	NA
Boresight Antenna Fixture	FBA-01	FBA-SIP01	NA	NA

##### Note:

1. The calibration interval of the above test instruments is 12 months and the calibrations are traceable to NML/ROC and NIST/USA.
2. \*The calibration interval of the above test instruments is 24 months and the calibrations are traceable to NML/ROC and NIST/USA.
3. The test was performed in 966 Chamber No. 3.
4. The CANADA Site Registration No. is 20331-1
5. Loop antenna was used for all emissions below 30 MHz.
6. Tested Date: Aug. 27 to 28, 2018

**Above 40GHz test:**

DESCRIPTION & MANUFACTURER	MODEL NO.	SERIAL NO.	CALIBRATED DATE	CALIBRATED UNTIL
Spectrum Analyzer Agilent	E4446A	MY48250254	Nov. 21, 2017	Nov. 20, 2018
*Harmonic Mixer (33~55GHz) OML	M22HWD	110215-1	Oct. 17, 2017	Oct. 16, 2019
*Horn Antenna (33~55GHz) OML	M22RH	110215-1	Oct. 17, 2017	Oct. 16, 2019
*Harmonic Mixer (50~75GHz) OML	M15RH	110215-1	Oct. 17, 2017	Oct. 16, 2019
*Horn Antenna (50~75GHz) OML	M15HWD	110215-1	Oct. 17, 2017	Oct. 16, 2019
*Harmonic Mixer (75~110GHz) OML	M10HWD	110215-1	Oct. 17, 2017	Oct. 16, 2019
*Horn Antenna (75~110GHz) OML	M10RH	110215-1	Oct. 17, 2017	Oct. 16, 2019
*Harmonic Mixer (110~170GHz) OML	M06RH	110215-1	Oct. 17, 2017	Oct. 16, 2019
*Horn Antenna(110~170GHz) OML	M06HWD	110215-1	Oct. 17, 2017	Oct. 16, 2019
*Harmonic Mixer (140~220GHz) OML	M05HWD	110215-1	Oct. 17, 2017	Oct. 16, 2019
*Horn Antenna (140~220GHz) OML	M05RH	110215-1	Oct. 17, 2017	Oct. 16, 2019
*Diplexer EMCI	DPL26	DPL26_01	Oct. 17, 2017	Oct. 16, 2019
*Diplexer EMCI	DPL26	DPL26_02	Oct. 17, 2017	Oct. 16, 2019
*Precision 30dB Attenuator Keysight	11708A	MY55260015	Oct. 17, 2017	Oct. 16, 2019
*Zero-Bias Detector (50~75GHz) Vdi	WR15ZBD	WR15R5 1-30	Oct. 17, 2017	Oct. 16, 2019
4CH Infiniivision Oscilloscope Keysight	DSOX6004A	MY55190202	Dec. 13, 2017	Dec. 12, 2018
*WR15CH Conical Horn Keysight	WR15CH	WR15CH-01	Oct. 17, 2017	Oct. 16, 2019
*WR10CH Conical Horn Keysight	WR10CH	WR10CH-01	Oct. 17, 2017	Oct. 16, 2019
*Millimeter-Wave Signal Generator Frequency Extension Module (50~75 GHz) Keysight	E8257DV15	US54250106	Oct. 17, 2017	Oct. 16, 2019
PSG analog signal generator Keysight	E8257D	MY53401987	June 26, 2018	June 25, 2019
Antenna Tower & Turn Table CT	NA	NA	NA	NA

**Note:**

1. The calibration interval of the above test instruments is 12 months and the calibrations are traceable to NML/ROC and NIST/USA.
2. \*The calibration interval of the above test instruments is 24 months and the calibrations are traceable to NML/ROC and NIST/USA.
3. The test was performed in 966 Chamber No. 3.
4. The CANADA Site Registration No. is 20331-1
6. Tested Date: Aug. 31, 2018



#### 4.1.3 Test Procedures

##### **For Radiated emission below 30MHz**

- a. The EUT was placed on the top of a rotating table 0.8 meters above the ground at a 3 meter chamber room. The table was rotated 360 degrees to determine the position of the highest radiation.
- b. The EUT was set 3 meters away from the interference-receiving antenna, which was mounted on the top of a variable-height antenna tower.
- c. Parallel, perpendicular, and ground-parallel orientations of the antenna are set to make the measurement.
- d. For each suspected emission, the EUT was arranged to its worst case and the rotatable table was turned from 0 degrees to 360 degrees to find the maximum reading.
- e. The test-receiver system was set to Quasi-Peak Detect Function and Specified Bandwidth with Maximum Hold Mode.

##### **NOTE:**

1. The resolution bandwidth and video bandwidth of test receiver/spectrum analyzer is 9kHz at frequency below 30MHz.

##### **For Radiated emission above 30MHz**

- a. The EUT was placed on the top of a rotating table 0.8 meters (for 30MHz ~ 1GHz) / 1.5 meters (for above 1GHz) above the ground at 3 meter chamber room for test. The table was rotated 360 degrees to determine the position of the highest radiation.
- b. The EUT was set 3 meters away from the interference-receiving antenna, which was mounted on the top of a variable-height antenna tower.
- c. The height of antenna is varied from one meter to four meters above the ground to determine the maximum value of the field strength. Both horizontal and vertical polarizations of the antenna are set to make the measurement.
- d. For each suspected emission, the EUT was arranged to its worst case and then the antenna was tuned to heights from 1 meter to 4 meters and the rotatable table was turned from 0 degrees to 360 degrees to find the maximum reading.
- e. The test-receiver system was set to quasi-peak detect function and specified bandwidth with maximum hold mode when the test frequency is below 1 GHz.
- f. The test-receiver system was set to peak and average detects function and specified bandwidth with maximum hold mode when the test frequency is above 1 GHz. If the peak reading value also meets average limit, measurement with the average detector is unnecessary.

##### **Note:**

1. The resolution bandwidth and video bandwidth of test receiver/spectrum analyzer is 120kHz for Quasi-peak detection (QP) at frequency below 1GHz.
2. The resolution bandwidth of test receiver/spectrum analyzer is 1 MHz and the video bandwidth is 3 MHz for Peak detection (PK) at frequency above 1GHz.
3. The resolution bandwidth of test receiver/spectrum analyzer is 1MHz and the video bandwidth is  $\geq 1/T$  (Duty cycle < 98%) or 10Hz (Duty cycle  $\geq 98\%$ ) for Average detection (AV) at frequency above 1GHz.
4. All modes of operation were investigated and the worst-case emissions are reported.

#### **For Radiated emission above 40GHz**

- a. Connect the test antenna covering the appropriate frequency range to a spectrum analyzer via an external mixer to the spectrum analyzer.
- b. Set spectrum analyzer RBW = 1 MHz, VBW = 3 MHz, average detector.
- c. Calculate the distance to the far field boundary and determine the maximum measurement distance.
- d. Perform an exploratory search for emissions and determine the approximate direction at which each observed emission emanates from the EUT.
- e. Exploratory measurements be made at a closer distance than the validated maximum measurement distance.
- f. Perform a final measurement; begin with the test antenna at the approximate position where the maximum level occurred during the exploratory scan.
- g. Slowly scan the test antenna around this position, slowly vary the test antenna polarization by rotating through at least 0° to 180°, and slowly vary the orientation of the test antenna to find the final position, polarization, and orientation at which the maximum level of the emission is observed.
- h. Record the measured reading with the test antenna fixed at this maximized position, polarization, and orientation. Record the measurement distance.
- i. Calculate the maximum field strength of the emission at the measurement distance and the adjusted/corrected power at the output of the test antenna.
- j. Calculate the EIRP from the measured field strength and then convert to the linear.
- k. Extrapolate the maximum measured field strength to the field strength at the distance specified by the limit, and then convert to the field strength in V/m.
- l. Calculate the power density at the distance specified by the limit from the field strength at the distance specified by the limit.
- m. Repeat the preceding sequence for every emission observed in the frequency band under investigation.

#### **4.1.4 Deviation from Test Standard**

No deviation.

#### 4.1.5 Test Setup

##### For Radiated emission below 30MHz

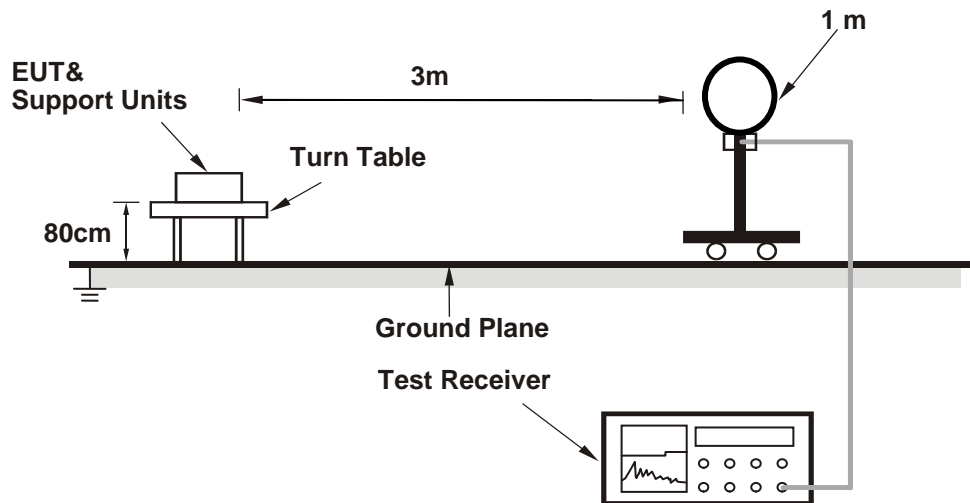

##### For Radiated emission 30MHz to 1GHz

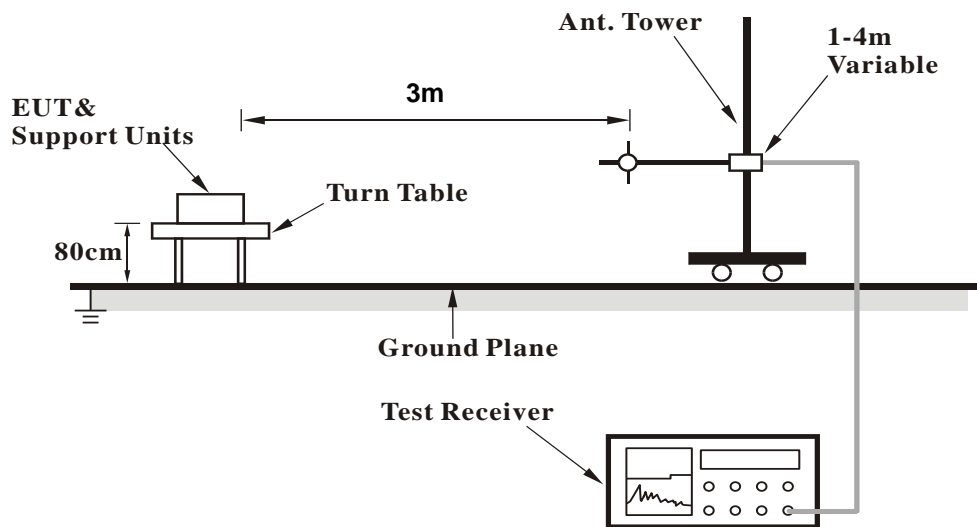

**For Radiated emission 1GHz to 40GHz**

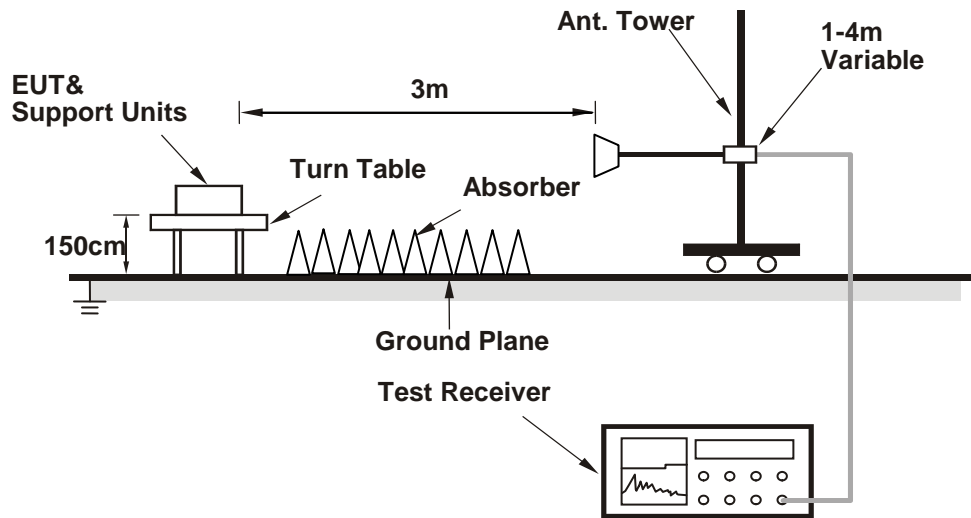

**For Radiated emission above 40 GHz**

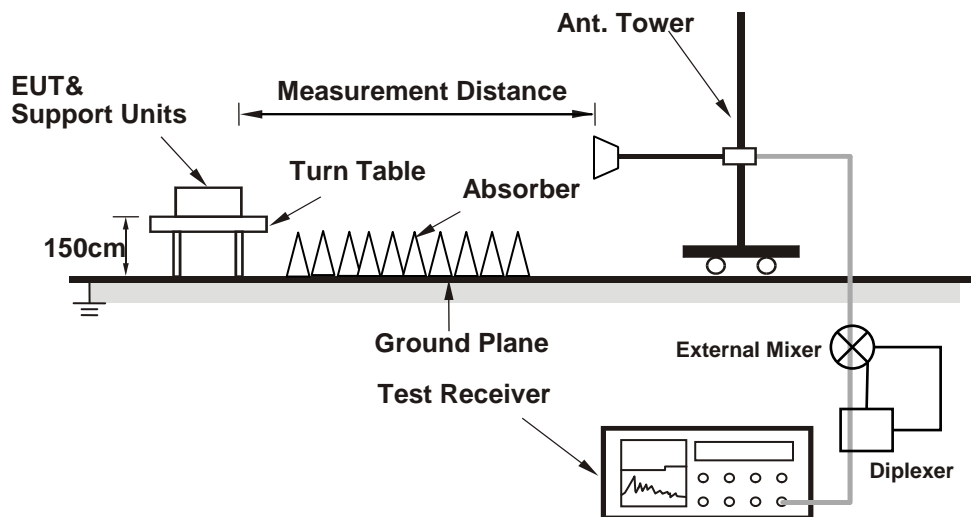

For the actual test configuration, please refer to the attached file (Test Setup Photo).

**4.1.6 EUT Operating Conditions**

- a. Connected the EUT with the Laptop which is placed on remote site.
- b. Controlling software has been activated to set the EUT on specific status.

#### 4.1.7 Test Results (LRP mode)

##### Channel Plan A

##### Above 1GHz Data:

<b>CHANNEL</b>	TX Channel 1	<b>DETECTOR FUNCTION</b>	Peak (PK)
<b>FREQUENCY RANGE</b>	1GHz ~ 18GHz		Average (AV)

#### ANTENNA POLARITY & TEST DISTANCE: HORIZONTAL AT 3 M

NO.	FREQ. (MHz)	EMISSION LEVEL (dBuV/m)	LIMIT (dBuV/m)	MARGIN (dB)	ANTENNA HEIGHT (m)	TABLE ANGLE (Degree)	RAW VALUE (dBuV)	CORRECTION FACTOR (dB/m)
1	2835.62	44.1 PK	74.0	-29.9	1.50 H	172	46.2	-2.1
2	2835.62	35.8 AV	54.0	-18.2	1.50 H	172	37.9	-2.1
3	10528.36	36.5 AV	54.0	-17.5	1.00 H	293	24.3	12.2
4	10528.36	47.5 PK	74.0	-26.5	1.00 H	293	35.3	12.2
5	14713.73	57.3 PK	74.0	-16.7	1.50 H	249	41.6	15.7
6	14713.73	47.4 AV	54.0	-6.6	1.50 H	249	31.7	15.7

#### ANTENNA POLARITY & TEST DISTANCE: VERTICAL AT 3 M

NO.	FREQ. (MHz)	EMISSION LEVEL (dBuV/m)	LIMIT (dBuV/m)	MARGIN (dB)	ANTENNA HEIGHT (m)	TABLE ANGLE (Degree)	RAW VALUE (dBuV)	CORRECTION FACTOR (dB/m)
1	3775.02	44.1 PK	74.0	-29.9	1.00 V	83	43.4	0.7
2	3775.02	33.9 AV	54.0	-20.1	1.00 V	83	33.2	0.7
3	8706.22	47.8 PK	74.0	-26.2	1.50 V	138	37.6	10.2
4	8706.22	36.2 AV	54.0	-17.8	1.50 V	138	26.0	10.2
5	13333.58	47.6 PK	74.0	-26.4	1.00 V	208	33.4	14.2
6	13333.58	34.9 AV	54.0	-19.1	1.00 V	208	20.7	14.2

#### REMARKS:

1. Emission Level(dBuV/m) = Raw Value(dBuV) + Correction Factor(dB/m)
2. Correction Factor(dB/m) = Antenna Factor(dB/m) + Cable Factor(dB) – Pre-Amplifier Factor(dB)
3. The other emission levels were very low against the limit.
4. Margin value = Emission Level – Limit value

<b>CHANNEL</b>	TX Channel 1	<b>DETECTOR FUNCTION</b>	Peak (PK)
<b>FREQUENCY RANGE</b>	18GHz ~ 40GHz		Average (AV)

**ANTENNA POLARITY & TEST DISTANCE: HORIZONTAL AT 3 M**

NO.	FREQ. (MHz)	EMISSION LEVEL (dBuV/m)	LIMIT (dBuV/m)	MARGIN (dB)	ANTENNA HEIGHT (m)	TABLE ANGLE (Degree)	RAW VALUE (dBuV)	CORRECTION FACTOR (dB/m)
1	24192.45	44.8 PK	74.0	-29.2	1.50 H	126	63.7	-18.9
2	24192.45	34.1 AV	54.0	-19.9	1.50 H	126	53.0	-18.9
3	29600.16	44.8 PK	74.0	-29.2	1.00 H	279	63.4	-18.6
4	29600.16	37.4 AV	54.0	-16.6	1.00 H	279	56.0	-18.6
5	34491.53	45.6 PK	74.0	-28.4	1.50 H	262	64.8	-19.2
6	34491.53	36.1 AV	54.0	-17.9	1.50 H	262	55.3	-19.2

**ANTENNA POLARITY & TEST DISTANCE: VERTICAL AT 3 M**

NO.	FREQ. (MHz)	EMISSION LEVEL (dBuV/m)	LIMIT (dBuV/m)	MARGIN (dB)	ANTENNA HEIGHT (m)	TABLE ANGLE (Degree)	RAW VALUE (dBuV)	CORRECTION FACTOR (dB/m)
1	21112.94	45.2 PK	74.0	-28.8	1.00 V	197	65.2	-20.0
2	21112.94	34.6 AV	54.0	-19.4	1.00 V	197	54.6	-20.0
3	27246.35	36.8 AV	54.0	-17.2	1.50 V	52	54.6	-17.8
4	27246.35	44.4 PK	74.0	-29.6	1.50 V	52	62.2	-17.8
5	31281.71	46.3 PK	74.0	-27.7	1.00 V	151	64.2	-17.9
6	31281.71	35.4 AV	54.0	-18.6	1.00 V	151	53.3	-17.9

**REMARKS:**

1. Emission Level(dBuV/m) = Raw Value(dBuV) + Correction Factor(dB/m)
2. Correction Factor(dB/m) = Antenna Factor(dB/m) + Cable Factor(dB) – Pre-Amplifier Factor(dB)
3. The other emission levels were very low against the limit.
4. Margin value = Emission Level – Limit value

<b>CHANNEL</b>	TX Channel 1	<b>DETECTOR FUNCTION</b>	Peak (PK)
<b>FREQUENCY RANGE</b>	40GHz ~ 200GHz		Average (AV)

**ANTENNA POLARITY & TEST DISTANCE: HORIZONTAL AT 3 M**

NO.	Frequency (GHz)	EIRP Level (dBm)	Reading Value (dBm)	Transmit Antenna Gain (dBi)	Power Density (pW/cm <sup>2</sup> )	Power Density Limit (pW/cm <sup>2</sup> )
1	43.15	-45.54	-69.54	24	0.025 PK	90
2	120.32	-35.08	-58.68	23.6	0.275 PK	90

**ANTENNA POLARITY & TEST DISTANCE: VERTICAL AT 3 M**

NO.	Frequency (GHz)	EIRP Level (dBm)	Reading Value (dBm)	Transmit Antenna Gain (dBi)	Power Density (pW/cm <sup>2</sup> )	Power Density Limit (pW/cm <sup>2</sup> )
1	43.43	-45.36	-69.36	24	0.026 PK	90
2	120.32	-35.12	-58.72	23.6	0.272 PK	90

<b>CHANNEL</b>	TX Channel 2	<b>DETECTOR FUNCTION</b>	Peak (PK)
<b>FREQUENCY RANGE</b>	1GHz ~ 18GHz		Average (AV)

**ANTENNA POLARITY & TEST DISTANCE: HORIZONTAL AT 3 M**

NO.	FREQ. (MHz)	EMISSION LEVEL (dBuV/m)	LIMIT (dBuV/m)	MARGIN (dB)	ANTENNA HEIGHT (m)	TABLE ANGLE (Degree)	RAW VALUE (dBuV)	CORRECTION FACTOR (dB/m)
1	2836.37	44.4 PK	74.0	-29.6	1.50 H	177	46.5	-2.1
2	2836.37	33.6 AV	54.0	-20.4	1.50 H	177	35.7	-2.1
3	10529.76	47.8 PK	74.0	-26.2	1.00 H	279	35.6	12.2
4	10529.76	36.2 AV	54.0	-17.8	1.00 H	279	24.0	12.2
5	14714.62	58.4 PK	74.0	-15.6	1.00 H	242	42.7	15.7
6	14714.62	47.3 AV	54.0	-6.7	1.00 H	242	31.6	15.7

**ANTENNA POLARITY & TEST DISTANCE: VERTICAL AT 3 M**

NO.	FREQ. (MHz)	EMISSION LEVEL (dBuV/m)	LIMIT (dBuV/m)	MARGIN (dB)	ANTENNA HEIGHT (m)	TABLE ANGLE (Degree)	RAW VALUE (dBuV)	CORRECTION FACTOR (dB/m)
1	3775.46	44.3 PK	74.0	-29.7	1.00 V	95	44.6	-0.3
2	3775.46	34.1 AV	54.0	-19.9	1.00 V	95	34.4	-0.3
3	8707.23	47.7 PK	74.0	-26.3	1.50 V	124	38.5	9.2
4	8707.23	36.4 AV	54.0	-17.6	1.50 V	124	27.2	9.2
5	13333.86	47.8 PK	74.0	-26.2	1.00 V	195	34.2	13.6
6	13333.86	34.8 AV	54.0	-19.2	1.00 V	195	21.2	13.6

**REMARKS:**

1. Emission Level(dBuV/m) = Raw Value(dBuV) + Correction Factor(dB/m)
2. Correction Factor(dB/m) = Antenna Factor(dB/m) + Cable Factor(dB) – Pre-Amplifier Factor(dB)
3. The other emission levels were very low against the limit.
4. Margin value = Emission Level – Limit value



<b>CHANNEL</b>	TX Channel 2	<b>DETECTOR FUNCTION</b>	Peak (PK)
<b>FREQUENCY RANGE</b>	18GHz ~ 40GHz		Average (AV)

**ANTENNA POLARITY & TEST DISTANCE: HORIZONTAL AT 3 M**

NO.	FREQ. (MHz)	EMISSION LEVEL (dBuV/m)	LIMIT (dBuV/m)	MARGIN (dB)	ANTENNA HEIGHT (m)	TABLE ANGLE (Degree)	RAW VALUE (dBuV)	CORRECTION FACTOR (dB/m)
1	24192.86	44.6 PK	74.0	-29.4	1.50 H	118	63.5	-18.9
2	24192.86	33.8 AV	54.0	-20.2	1.50 H	118	52.7	-18.9
3	29601.98	44.7 PK	74.0	-29.3	1.00 H	262	63.3	-18.6
4	29601.98	37.2 AV	54.0	-16.8	1.00 H	262	55.8	-18.6
5	34491.75	45.8 PK	74.0	-28.2	1.50 H	283	65.0	-19.2
6	34491.75	35.9 AV	54.0	-18.1	1.50 H	283	55.1	-19.2

**ANTENNA POLARITY & TEST DISTANCE: VERTICAL AT 3 M**

NO.	FREQ. (MHz)	EMISSION LEVEL (dBuV/m)	LIMIT (dBuV/m)	MARGIN (dB)	ANTENNA HEIGHT (m)	TABLE ANGLE (Degree)	RAW VALUE (dBuV)	CORRECTION FACTOR (dB/m)
1	21112.72	34.5 AV	54.0	-19.5	1.00 V	180	54.5	-20.0
2	21112.72	45.4 PK	74.0	-28.6	1.00 V	180	65.4	-20.0
3	27246.67	44.7 PK	74.0	-29.3	1.50 V	62	62.5	-17.8
4	27246.67	37.0 AV	54.0	-17.0	1.50 V	62	54.8	-17.8
5	31281.29	35.1 AV	54.0	-18.9	1.00 V	139	53.0	-17.9
6	31281.29	46.5 PK	74.0	-27.5	1.00 V	139	64.4	-17.9

**REMARKS:**

1. Emission Level(dBuV/m) = Raw Value(dBuV) + Correction Factor(dB/m)
2. Correction Factor(dB/m) = Antenna Factor(dB/m) + Cable Factor(dB) – Pre-Amplifier Factor(dB)
3. The other emission levels were very low against the limit.
4. Margin value = Emission Level – Limit value

<b>CHANNEL</b>	TX Channel 2	<b>DETECTOR FUNCTION</b>	Peak (PK)
<b>FREQUENCY RANGE</b>	40GHz ~ 200GHz		Average (AV)

**ANTENNA POLARITY & TEST DISTANCE: HORIZONTAL AT 3 M**

NO.	Frequency (GHz)	EIRP Level (dBm)	Reading Value (dBm)	Transmit Antenna Gain (dBi)	Power Density (pW/cm <sup>2</sup> )	Power Density Limit (pW/cm <sup>2</sup> )
1	43.35	-45.35	-69.35	24	0.026 PK	90
2	120.96	-34.64	-58.24	23.6	0.304 PK	90

**ANTENNA POLARITY & TEST DISTANCE: VERTICAL AT 3 M**

NO.	Frequency (GHz)	EIRP Level (dBm)	Reading Value (dBm)	Transmit Antenna Gain (dBi)	Power Density (pW/cm <sup>2</sup> )	Power Density Limit (pW/cm <sup>2</sup> )
1	43.67	-45.24	-69.24	24	0.026 PK	90
2	120.96	-34.77	-58.37	23.6	0.295 PK	90

<b>CHANNEL</b>	TX Channel 3	<b>DETECTOR FUNCTION</b>	Peak (PK)
<b>FREQUENCY RANGE</b>	1GHz ~ 18GHz		Average (AV)

**ANTENNA POLARITY & TEST DISTANCE: HORIZONTAL AT 3 M**

NO.	FREQ. (MHz)	EMISSION LEVEL (dBuV/m)	LIMIT (dBuV/m)	MARGIN (dB)	ANTENNA HEIGHT (m)	TABLE ANGLE (Degree)	RAW VALUE (dBuV)	CORRECTION FACTOR (dB/m)
1	2834.41	44.2 PK	74.0	-29.8	1.50 H	163	46.3	-2.1
2	2834.41	33.3 AV	54.0	-20.7	1.50 H	163	35.4	-2.1
3	10525.49	48.2 PK	74.0	-25.8	1.00 H	257	36.0	12.2
4	10525.49	36.3 AV	54.0	-17.7	1.50 H	257	24.1	12.2
5	14713.96	58.2 PK	74.0	-15.8	1.50 H	233	42.5	15.7
6	14713.96	46.6 AV	54.0	-7.4	1.50 H	233	30.9	15.7

**ANTENNA POLARITY & TEST DISTANCE: VERTICAL AT 3 M**

NO.	FREQ. (MHz)	EMISSION LEVEL (dBuV/m)	LIMIT (dBuV/m)	MARGIN (dB)	ANTENNA HEIGHT (m)	TABLE ANGLE (Degree)	RAW VALUE (dBuV)	CORRECTION FACTOR (dB/m)
1	3775.23	44.6 PK	74.0	-29.4	1.00 V	81	44.9	-0.3
2	3775.23	33.8 AV	54.0	-20.2	1.00 V	81	34.1	-0.3
3	8707.92	47.5 PK	74.0	-26.5	1.50 V	118	38.3	9.2
4	8707.92	36.8 AV	54.0	-17.2	1.50 V	118	27.6	9.2
5	13333.53	47.6 PK	74.0	-26.4	1.00 V	180	34.0	13.6
6	13333.53	34.7 AV	54.0	-19.3	1.00 V	180	21.1	13.6

**REMARKS:**

1. Emission Level(dBuV/m) = Raw Value(dBuV) + Correction Factor(dB/m)
2. Correction Factor(dB/m) = Antenna Factor(dB/m) + Cable Factor(dB) – Pre-Amplifier Factor(dB)
3. The other emission levels were very low against the limit.
4. Margin value = Emission Level – Limit value

<b>CHANNEL</b>	TX Channel 3	<b>DETECTOR FUNCTION</b>	Peak (PK)
<b>FREQUENCY RANGE</b>	18GHz ~ 40GHz		Average (AV)

**ANTENNA POLARITY & TEST DISTANCE: HORIZONTAL AT 3 M**

NO.	FREQ. (MHz)	EMISSION LEVEL (dBuV/m)	LIMIT (dBuV/m)	MARGIN (dB)	ANTENNA HEIGHT (m)	TABLE ANGLE (Degree)	RAW VALUE (dBuV)	CORRECTION FACTOR (dB/m)
1	24193.63	44.9 PK	74.0	-29.1	1.00 H	107	63.8	-18.9
2	24193.63	33.6 AV	54.0	-20.4	1.00 H	107	52.5	-18.9
3	29602.16	44.9 PK	74.0	-29.1	1.00 H	248	63.5	-18.6
4	29602.16	37.0 AV	54.0	-17.0	1.00 H	248	55.6	-18.6
5	34491.31	45.6 PK	74.0	-28.4	1.50 H	298	64.8	-19.2
6	34491.31	35.7 AV	54.0	-18.3	1.50 H	298	54.9	-19.2

**ANTENNA POLARITY & TEST DISTANCE: VERTICAL AT 3 M**

NO.	FREQ. (MHz)	EMISSION LEVEL (dBuV/m)	LIMIT (dBuV/m)	MARGIN (dB)	ANTENNA HEIGHT (m)	TABLE ANGLE (Degree)	RAW VALUE (dBuV)	CORRECTION FACTOR (dB/m)
1	21113.15	34.3 AV	54.0	-19.7	1.00 V	165	54.3	-20.0
2	21113.15	45.1 PK	74.0	-28.9	1.00 V	165	65.1	-20.0
3	27246.43	37.7 AV	54.0	-16.3	1.50 V	79	55.5	-17.8
4	27246.43	44.8 PK	74.0	-29.2	1.50 V	79	62.6	-17.8
5	31282.71	46.7 PK	74.0	-27.3	1.00 V	153	64.6	-17.9
6	31282.71	35.2 AV	54.0	-18.8	1.00 V	153	53.1	-17.9

**REMARKS:**

1. Emission Level(dBuV/m) = Raw Value(dBuV) + Correction Factor(dB/m)
2. Correction Factor(dB/m) = Antenna Factor(dB/m) + Cable Factor(dB) – Pre-Amplifier Factor(dB)
3. The other emission levels were very low against the limit.
4. Margin value = Emission Level – Limit value

<b>CHANNEL</b>	TX Channel 3	<b>DETECTOR FUNCTION</b>	Peak (PK)
<b>FREQUENCY RANGE</b>	40GHz ~ 200GHz		Average (AV)

**ANTENNA POLARITY & TEST DISTANCE: HORIZONTAL AT 3 M**

NO.	Frequency (GHz)	EIRP Level (dBm)	Reading Value (dBm)	Transmit Antenna Gain (dBi)	Power Density (pW/cm <sup>2</sup> )	Power Density Limit (pW/cm <sup>2</sup> )
1	43.46	-45.12	-69.12	24	0.027 PK	90
2	121.6	-34.99	-58.59	23.6	0.28 PK	90

**ANTENNA POLARITY & TEST DISTANCE: VERTICAL AT 3 M**

NO.	Frequency (GHz)	EIRP Level (dBm)	Reading Value (dBm)	Transmit Antenna Gain (dBi)	Power Density (pW/cm <sup>2</sup> )	Power Density Limit (pW/cm <sup>2</sup> )
1	43.22	-45.34	-69.34	24	0.026 PK	90
2	121.6	-35.02	-58.62	23.6	0.278 PK	90

**Below 1GHz Data:**

<b>CHANNEL</b>	TX Channel 1	<b>DETECTOR FUNCTION</b>	Quasi-Peak (QP)
<b>FREQUENCY RANGE</b>	9kHz ~ 1GHz		

ANTENNA POLARITY & TEST DISTANCE: HORIZONTAL AT 3 M								
NO.	FREQ. (MHz)	EMISSION LEVEL (dBuV/m)	LIMIT (dBuV/m)	MARGIN (dB)	ANTENNA HEIGHT (m)	TABLE ANGLE (Degree)	RAW VALUE (dBuV)	CORRECTION FACTOR (dB/m)
1	32.40	35.1 QP	40.0	-4.9	1.53 H	265	44.1	-9.0
2	237.35	41.6 QP	46.0	-4.4	1.50 H	221	51.0	-9.4
3	503.60	40.3 QP	46.0	-5.7	1.50 H	241	42.2	-1.9
4	575.72	42.1 QP	46.0	-3.9	2.00 H	194	42.5	-0.4
5	791.79	40.3 QP	46.0	-5.7	2.50 H	313	36.6	3.7
6	891.01	41.7 QP	46.0	-4.3	1.50 H	241	36.9	4.8

**REMARKS:**

1. Emission Level(dBuV/m) = Raw Value(dBuV) + Correction Factor(dB/m)
2. Correction Factor(dB/m) = Antenna Factor(dB/m) + Cable Factor(dB) – Pre-Amplifier Factor(dB)
3. The other emission levels were very low against the limit.
4. Margin value = Emission Level – Limit value

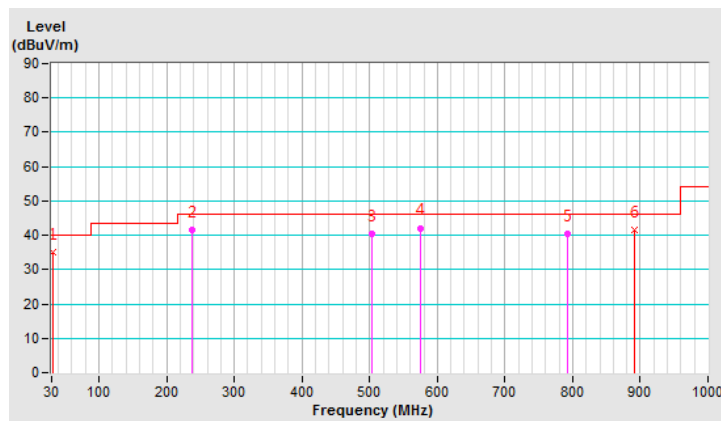

<b>CHANNEL</b>	TX Channel 1	<b>DETECTOR FUNCTION</b>	Quasi-Peak (QP)
<b>FREQUENCY RANGE</b>	9kHz ~ 1GHz		

**ANTENNA POLARITY & TEST DISTANCE: VERTICAL AT 3 M**

NO.	FREQ. (MHz)	EMISSION LEVEL (dBuV/m)	LIMIT (dBuV/m)	MARGIN (dB)	ANTENNA HEIGHT (m)	TABLE ANGLE (Degree)	RAW VALUE (dBuV)	CORRECTION FACTOR (dB/m)
1	32.33	35.5 QP	40.0	-4.5	1.00 V	162	44.5	-9.0
2	431.87	41.2 QP	46.0	-4.8	1.00 V	231	44.4	-3.2
3	503.85	41.3 QP	46.0	-4.7	1.00 V	118	43.2	-1.9
4	575.74	41.4 QP	46.0	-4.6	1.00 V	264	41.8	-0.4
5	863.93	40.4 QP	46.0	-5.6	1.50 V	261	36.0	4.4
6	891.15	41.7 QP	46.0	-4.3	1.00 V	331	36.9	4.8

**REMARKS:**

1. Emission Level(dBuV/m) = Raw Value(dBuV) + Correction Factor(dB/m)
2. Correction Factor(dB/m) = Antenna Factor(dB/m) + Cable Factor(dB) – Pre-Amplifier Factor(dB)
3. The other emission levels were very low against the limit.
4. Margin value = Emission Level – Limit value

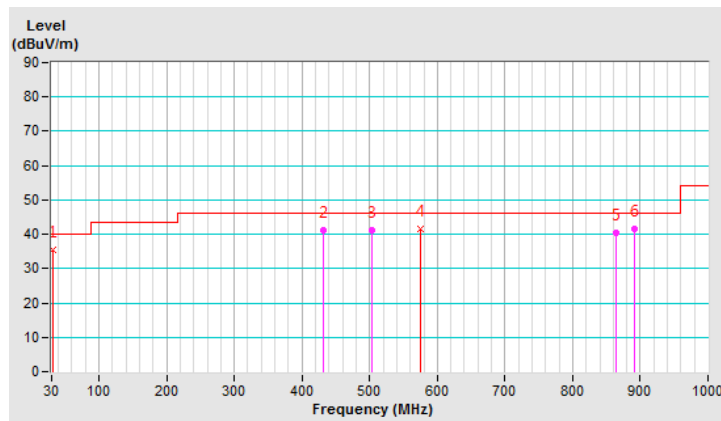

<b>CHANNEL</b>	TX Channel 2	<b>DETECTOR FUNCTION</b>	Quasi-Peak (QP)
<b>FREQUENCY RANGE</b>	9kHz ~ 1GHz		

**ANTENNA POLARITY & TEST DISTANCE: HORIZONTAL AT 3 M**

NO.	FREQ. (MHz)	EMISSION LEVEL (dBuV/m)	LIMIT (dBuV/m)	MARGIN (dB)	ANTENNA HEIGHT (m)	TABLE ANGLE (Degree)	RAW VALUE (dBuV)	CORRECTION FACTOR (dB/m)
1	32.40	35.2 QP	40.0	-4.8	1.62 H	360	44.2	-9.0
2	237.34	41.8 QP	46.0	-4.2	1.50 H	360	51.2	-9.4
3	503.60	40.4 QP	46.0	-5.6	1.50 H	308	42.3	-1.9
4	575.72	42.2 QP	46.0	-3.8	2.00 H	360	42.6	-0.4
5	791.79	40.4 QP	46.0	-5.6	2.50 H	300	36.7	3.7
6	891.01	41.8 QP	46.0	-4.2	1.50 H	299	37.0	4.8

**REMARKS:**

1. Emission Level(dBuV/m) = Raw Value(dBuV) + Correction Factor(dB/m)
2. Correction Factor(dB/m) = Antenna Factor(dB/m) + Cable Factor(dB) – Pre-Amplifier Factor(dB)
3. The other emission levels were very low against the limit.
4. Margin value = Emission Level – Limit value

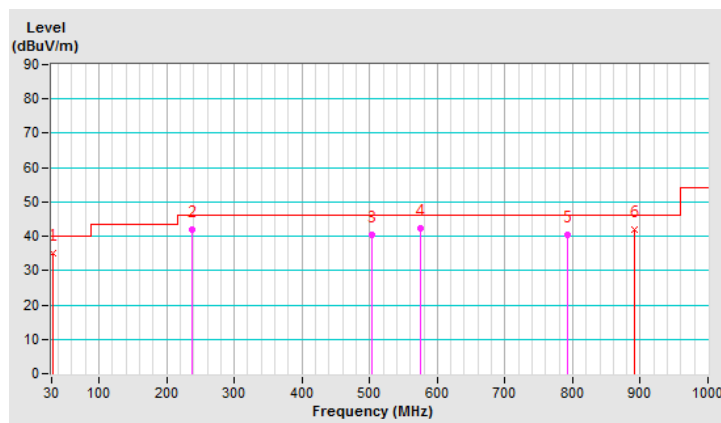



<b>CHANNEL</b>	TX Channel 2	<b>DETECTOR FUNCTION</b>	Quasi-Peak (QP)
<b>FREQUENCY RANGE</b>	9kHz ~ 1GHz		

**ANTENNA POLARITY & TEST DISTANCE: VERTICAL AT 3 M**

NO.	FREQ. (MHz)	EMISSION LEVEL (dBuV/m)	LIMIT (dBuV/m)	MARGIN (dB)	ANTENNA HEIGHT (m)	TABLE ANGLE (Degree)	RAW VALUE (dBuV)	CORRECTION FACTOR (dB/m)
1	32.33	35.6 QP	40.0	-4.4	1.00 V	215	44.6	-9.0
2	431.87	41.0 QP	46.0	-5.0	1.00 V	149	44.2	-3.2
3	503.85	41.4 QP	46.0	-4.6	1.00 V	267	43.3	-1.9
4	575.74	41.5 QP	46.0	-4.5	1.01 V	305	41.9	-0.4
5	863.93	40.6 QP	46.0	-5.4	2.00 V	327	36.2	4.4
6	891.14	41.9 QP	46.0	-4.1	1.00 V	360	37.1	4.8

**REMARKS:**

1. Emission Level(dBuV/m) = Raw Value(dBuV) + Correction Factor(dB/m)
2. Correction Factor(dB/m) = Antenna Factor(dB/m) + Cable Factor(dB) – Pre-Amplifier Factor(dB)
3. The other emission levels were very low against the limit.
4. Margin value = Emission Level – Limit value

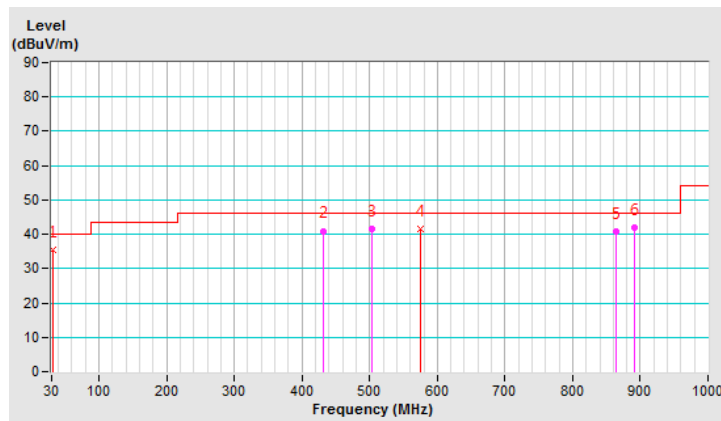

<b>CHANNEL</b>	TX Channel 3	<b>DETECTOR FUNCTION</b>	Quasi-Peak (QP)
<b>FREQUENCY RANGE</b>	9kHz ~ 1GHz		

**ANTENNA POLARITY & TEST DISTANCE: HORIZONTAL AT 3 M**

NO.	FREQ. (MHz)	EMISSION LEVEL (dBuV/m)	LIMIT (dBuV/m)	MARGIN (dB)	ANTENNA HEIGHT (m)	TABLE ANGLE (Degree)	RAW VALUE (dBuV)	CORRECTION FACTOR (dB/m)
1	32.40	35.0 QP	40.0	-5.0	1.49 H	187	44.0	-9.0
2	237.35	41.4 QP	46.0	-4.6	1.50 H	305	50.8	-9.4
3	503.60	40.5 QP	46.0	-5.5	2.00 H	221	42.4	-1.9
4	575.72	41.9 QP	46.0	-4.1	1.50 H	206	42.3	-0.4
5	791.79	40.5 QP	46.0	-5.5	2.00 H	334	36.8	3.7
6	891.01	41.5 QP	46.0	-4.5	1.19 H	281	36.7	4.8

**REMARKS:**

1. Emission Level(dBuV/m) = Raw Value(dBuV) + Correction Factor(dB/m)
2. Correction Factor(dB/m) = Antenna Factor(dB/m) + Cable Factor(dB) – Pre-Amplifier Factor(dB)
3. The other emission levels were very low against the limit.
4. Margin value = Emission Level – Limit value

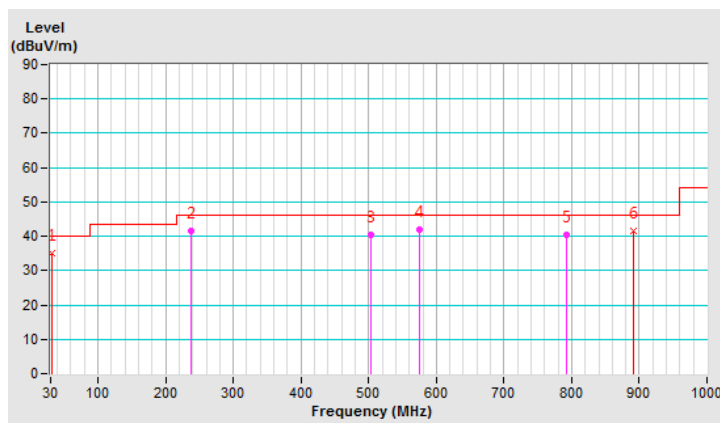

<b>CHANNEL</b>	TX Channel 3	<b>DETECTOR FUNCTION</b>	Quasi-Peak (QP)
<b>FREQUENCY RANGE</b>	9kHz ~ 1GHz		

**ANTENNA POLARITY & TEST DISTANCE: VERTICAL AT 3 M**

NO.	FREQ. (MHz)	EMISSION LEVEL (dBuV/m)	LIMIT (dBuV/m)	MARGIN (dB)	ANTENNA HEIGHT (m)	TABLE ANGLE (Degree)	RAW VALUE (dBuV)	CORRECTION FACTOR (dB/m)
1	32.34	35.7 QP	40.0	-4.3	1.00 V	89	44.7	-9.0
2	431.86	41.3 QP	46.0	-4.7	1.00 V	313	44.5	-3.2
3	503.85	41.4 QP	46.0	-4.6	1.09 V	287	43.3	-1.9
4	575.74	41.6 QP	46.0	-4.4	1.00 V	224	42.0	-0.4
5	863.93	40.6 QP	46.0	-5.4	1.50 V	360	36.2	4.4
6	891.15	41.3 QP	46.0	-4.7	1.00 V	254	36.5	4.8

**REMARKS:**

1. Emission Level(dBuV/m) = Raw Value(dBuV) + Correction Factor(dB/m)
2. Correction Factor(dB/m) = Antenna Factor(dB/m) + Cable Factor(dB) – Pre-Amplifier Factor(dB)
3. The other emission levels were very low against the limit.
4. Margin value = Emission Level – Limit value

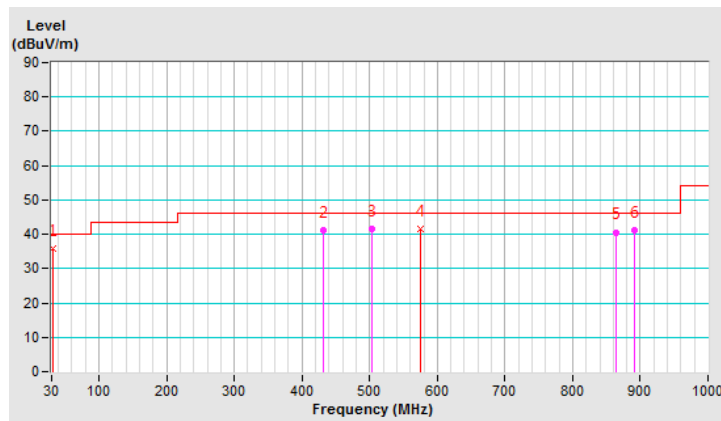

## Channel Plan B

### Above 1GHz Data:

<b>CHANNEL</b>	TX Channel 1	<b>DETECTOR FUNCTION</b>	Peak (PK)
<b>FREQUENCY RANGE</b>	1GHz ~ 18GHz		Average (AV)

#### ANTENNA POLARITY & TEST DISTANCE: HORIZONTAL AT 3 M

NO.	FREQ. (MHz)	EMISSION LEVEL (dBuV/m)	LIMIT (dBuV/m)	MARGIN (dB)	ANTENNA HEIGHT (m)	TABLE ANGLE (Degree)	RAW VALUE (dBuV)	CORRECTION FACTOR (dB/m)
1	2835.55	45.1 PK	74.0	-28.9	1.00 H	184	47.2	-2.1
2	2835.55	33.7 AV	54.0	-20.3	1.00 H	184	35.8	-2.1
3	10526.15	47.5 PK	74.0	-26.5	1.50 H	241	35.3	12.2
4	10526.15	36.9 AV	54.0	-17.1	1.50 H	241	24.7	12.2
5	14712.83	58.1 PK	74.0	-15.9	1.50 H	219	42.4	15.7
6	14712.83	46.4 AV	54.0	-7.6	1.50 H	219	30.7	15.7

#### ANTENNA POLARITY & TEST DISTANCE: VERTICAL AT 3 M

NO.	FREQ. (MHz)	EMISSION LEVEL (dBuV/m)	LIMIT (dBuV/m)	MARGIN (dB)	ANTENNA HEIGHT (m)	TABLE ANGLE (Degree)	RAW VALUE (dBuV)	CORRECTION FACTOR (dB/m)
1	3775.56	44.3 PK	74.0	-29.7	1.00 V	99	44.6	-0.3
2	3775.56	34.2 AV	54.0	-19.8	1.00 V	99	34.5	-0.3
3	8706.95	47.4 PK	74.0	-26.6	1.50 V	104	38.2	9.2
4	8706.95	36.5 AV	54.0	-17.5	1.50 V	104	27.3	9.2
5	13333.79	47.7 PK	74.0	-26.3	1.00 V	195	34.1	13.6
6	13333.79	34.3 AV	54.0	-19.7	1.00 V	195	20.7	13.6

#### REMARKS:

1. Emission Level(dBuV/m) = Raw Value(dBuV) + Correction Factor(dB/m)
2. Correction Factor(dB/m) = Antenna Factor(dB/m) + Cable Factor(dB) – Pre-Amplifier Factor(dB)
3. The other emission levels were very low against the limit.
4. Margin value = Emission Level – Limit value

<b>CHANNEL</b>	TX Channel 1	<b>DETECTOR FUNCTION</b>	Peak (PK)
<b>FREQUENCY RANGE</b>	18GHz ~ 40GHz		Average (AV)

**ANTENNA POLARITY & TEST DISTANCE: HORIZONTAL AT 3 M**

NO.	FREQ. (MHz)	EMISSION LEVEL (dBuV/m)	LIMIT (dBuV/m)	MARGIN (dB)	ANTENNA HEIGHT (m)	TABLE ANGLE (Degree)	RAW VALUE (dBuV)	CORRECTION FACTOR (dB/m)
1	24194.12	45.2 PK	74.0	-28.8	1.00 H	139	64.1	-18.9
2	24194.12	34.5 AV	54.0	-19.5	1.00 H	139	53.4	-18.9
3	29602.83	44.7 PK	74.0	-29.3	1.00 H	227	63.3	-18.6
4	29602.83	37.2 AV	54.0	-16.8	1.00 H	227	55.8	-18.6
5	34491.77	45.8 PK	74.0	-28.2	1.50 H	281	65.0	-19.2
6	34491.77	35.6 AV	54.0	-18.4	1.50 H	281	54.8	-19.2

**ANTENNA POLARITY & TEST DISTANCE: VERTICAL AT 3 M**

NO.	FREQ. (MHz)	EMISSION LEVEL (dBuV/m)	LIMIT (dBuV/m)	MARGIN (dB)	ANTENNA HEIGHT (m)	TABLE ANGLE (Degree)	RAW VALUE (dBuV)	CORRECTION FACTOR (dB/m)
1	21113.82	45.5 PK	74.0	-28.5	1.00 V	144	65.5	-20.0
2	21113.82	34.1 AV	54.0	-19.9	1.00 V	144	54.1	-20.0
3	27246.75	44.4 PK	74.0	-29.6	1.50 V	64	62.2	-17.8
4	27246.75	37.9 AV	54.0	-16.1	1.50 V	64	55.7	-17.8
5	31283.04	46.6 PK	74.0	-27.4	1.00 V	148	64.5	-17.9
6	31283.04	35.1 AV	54.0	-18.9	1.00 V	148	53.0	-17.9

**REMARKS:**

1. Emission Level(dBuV/m) = Raw Value(dBuV) + Correction Factor(dB/m)
2. Correction Factor(dB/m) = Antenna Factor(dB/m) + Cable Factor(dB) – Pre-Amplifier Factor(dB)
3. The other emission levels were very low against the limit.
4. Margin value = Emission Level – Limit value

<b>CHANNEL</b>	TX Channel 1	<b>DETECTOR FUNCTION</b>	Peak (PK)
<b>FREQUENCY RANGE</b>	40GHz ~ 200GHz		Average (AV)

**ANTENNA POLARITY & TEST DISTANCE: HORIZONTAL AT 3 M**

NO.	Frequency (GHz)	EIRP Level (dBm)	Reading Value (dBm)	Transmit Antenna Gain (dBi)	Power Density (pW/cm <sup>2</sup> )	Power Density Limit (pW/cm <sup>2</sup> )
1	48.41	-44.11	-68.11	24	0.034 PK	90
2	124.64	-34.85	-58.45	23.6	0.289 PK	90

**ANTENNA POLARITY & TEST DISTANCE: VERTICAL AT 3 M**

NO.	Frequency (GHz)	EIRP Level (dBm)	Reading Value (dBm)	Transmit Antenna Gain (dBi)	Power Density (pW/cm <sup>2</sup> )	Power Density Limit (pW/cm <sup>2</sup> )
1	48.35	-45.24	-69.24	24	0.026 PK	90
2	124.64	-35.07	-58.67	23.6	0.275 PK	90

<b>CHANNEL</b>	TX Channel 2	<b>DETECTOR FUNCTION</b>	Peak (PK)
<b>FREQUENCY RANGE</b>	1GHz ~ 18GHz		Average (AV)

**ANTENNA POLARITY & TEST DISTANCE: HORIZONTAL AT 3 M**

NO.	FREQ. (MHz)	EMISSION LEVEL (dBuV/m)	LIMIT (dBuV/m)	MARGIN (dB)	ANTENNA HEIGHT (m)	TABLE ANGLE (Degree)	RAW VALUE (dBuV)	CORRECTION FACTOR (dB/m)
1	2835.93	45.3 PK	74.0	-28.7	1.00 H	169	47.4	-2.1
2	2835.93	33.2 AV	54.0	-20.8	1.00 H	169	35.3	-2.1
3	10527.48	47.7 PK	74.0	-26.3	1.50 H	228	35.5	12.2
4	10527.48	36.7 AV	54.0	-17.3	1.50 H	228	24.5	12.2
5	14711.69	58.4 PK	74.0	-15.6	1.50 H	209	42.7	15.7
6	14711.69	46.2 AV	54.0	-7.8	1.50 H	209	30.5	15.7

**ANTENNA POLARITY & TEST DISTANCE: VERTICAL AT 3 M**

NO.	FREQ. (MHz)	EMISSION LEVEL (dBuV/m)	LIMIT (dBuV/m)	MARGIN (dB)	ANTENNA HEIGHT (m)	TABLE ANGLE (Degree)	RAW VALUE (dBuV)	CORRECTION FACTOR (dB/m)
1	3775.34	44.2 PK	74.0	-29.8	1.00 V	87	44.5	-0.3
2	3775.34	33.9 AV	54.0	-20.1	1.00 V	87	34.2	-0.3
3	8705.72	46.9 PK	74.0	-27.1	1.50 V	93	37.7	9.2
4	8705.72	35.2 AV	54.0	-18.8	1.50 V	93	26.0	9.2
5	13334.62	47.4 PK	74.0	-26.6	1.50 V	182	33.8	13.6
6	13334.62	33.8 AV	54.0	-20.2	1.50 V	182	20.2	13.6

**REMARKS:**

1. Emission Level(dBuV/m) = Raw Value(dBuV) + Correction Factor(dB/m)
2. Correction Factor(dB/m) = Antenna Factor(dB/m) + Cable Factor(dB) – Pre-Amplifier Factor(dB)
3. The other emission levels were very low against the limit.
4. Margin value = Emission Level – Limit value

<b>CHANNEL</b>	TX Channel 2	<b>DETECTOR FUNCTION</b>	Peak (PK)
<b>FREQUENCY RANGE</b>	18GHz ~ 40GHz		Average (AV)

**ANTENNA POLARITY & TEST DISTANCE: HORIZONTAL AT 3 M**

NO.	FREQ. (MHz)	EMISSION LEVEL (dBuV/m)	LIMIT (dBuV/m)	MARGIN (dB)	ANTENNA HEIGHT (m)	TABLE ANGLE (Degree)	RAW VALUE (dBuV)	CORRECTION FACTOR (dB/m)
1	24194.44	46.4 PK	74.0	-27.6	1.00 H	152	65.3	-18.9
2	24194.44	35.7 AV	54.0	-18.3	1.00 H	152	54.6	-18.9
3	29602.59	37.4 AV	54.0	-16.6	1.00 H	205	56.0	-18.6
4	29602.59	44.9 PK	74.0	-29.1	1.00 H	205	63.5	-18.6
5	34491.33	45.9 PK	74.0	-28.1	1.50 H	292	65.1	-19.2
6	34491.33	36.2 AV	54.0	-17.8	1.50 H	292	55.4	-19.2

**ANTENNA POLARITY & TEST DISTANCE: VERTICAL AT 3 M**

NO.	FREQ. (MHz)	EMISSION LEVEL (dBuV/m)	LIMIT (dBuV/m)	MARGIN (dB)	ANTENNA HEIGHT (m)	TABLE ANGLE (Degree)	RAW VALUE (dBuV)	CORRECTION FACTOR (dB/m)
1	21113.38	34.4 AV	54.0	-19.6	1.50 V	127	54.4	-20.0
2	21113.38	44.7 PK	74.0	-29.3	1.50 V	127	64.7	-20.0
3	27247.08	44.6 PK	74.0	-29.4	1.50 V	77	62.4	-17.8
4	27247.08	37.7 AV	54.0	-16.3	1.50 V	77	55.5	-17.8
5	31283.66	46.8 PK	74.0	-27.2	1.00 V	138	64.7	-17.9
6	31283.66	35.2 AV	54.0	-18.8	1.00 V	138	53.1	-17.9

**REMARKS:**

1. Emission Level(dBuV/m) = Raw Value(dBuV) + Correction Factor(dB/m)
2. Correction Factor(dB/m) = Antenna Factor(dB/m) + Cable Factor(dB) – Pre-Amplifier Factor(dB)
3. The other emission levels were very low against the limit.
4. Margin value = Emission Level – Limit value



<b>CHANNEL</b>	TX Channel 2	<b>DETECTOR FUNCTION</b>	Peak (PK)
<b>FREQUENCY RANGE</b>	40GHz ~ 200GHz		Average (AV)

**ANTENNA POLARITY & TEST DISTANCE: HORIZONTAL AT 3 M**

NO.	Frequency (GHz)	EIRP Level (dBm)	Reading Value (dBm)	Transmit Antenna Gain (dBi)	Power Density (pW/cm <sup>2</sup> )	Power Density Limit (pW/cm <sup>2</sup> )
1	48.32	-44.25	-68.25	24	0.033 PK	90
2	125.28	-34.76	-58.36	23.6	0.296 PK	90

**ANTENNA POLARITY & TEST DISTANCE: VERTICAL AT 3 M**

NO.	Frequency (GHz)	EIRP Level (dBm)	Reading Value (dBm)	Transmit Antenna Gain (dBi)	Power Density (pW/cm <sup>2</sup> )	Power Density Limit (pW/cm <sup>2</sup> )
1	48.47	-45.13	-69.13	24	0.027 PK	90
2	125.28	-34.94	-58.54	23.6	0.284 PK	90

<b>CHANNEL</b>	TX Channel 3	<b>DETECTOR FUNCTION</b>	Peak (PK)
<b>FREQUENCY RANGE</b>	1GHz ~ 18GHz		Average (AV)

**ANTENNA POLARITY & TEST DISTANCE: HORIZONTAL AT 3 M**

NO.	FREQ. (MHz)	EMISSION LEVEL (dBuV/m)	LIMIT (dBuV/m)	MARGIN (dB)	ANTENNA HEIGHT (m)	TABLE ANGLE (Degree)	RAW VALUE (dBuV)	CORRECTION FACTOR (dB/m)
1	2836.61	45.1 PK	74.0	-28.9	1.00 H	157	47.2	-2.1
2	2836.61	33.4 AV	54.0	-20.6	1.00 H	157	35.5	-2.1
3	10526.81	36.9 AV	54.0	-17.1	1.50 H	204	24.7	12.2
4	10526.81	47.5 PK	74.0	-26.5	1.50 H	204	35.3	12.2
5	14712.77	58.2 PK	74.0	-15.8	1.50 H	197	42.5	15.7
6	14712.77	46.5 AV	54.0	-7.5	1.50 H	197	30.8	15.7

**ANTENNA POLARITY & TEST DISTANCE: VERTICAL AT 3 M**

NO.	FREQ. (MHz)	EMISSION LEVEL (dBuV/m)	LIMIT (dBuV/m)	MARGIN (dB)	ANTENNA HEIGHT (m)	TABLE ANGLE (Degree)	RAW VALUE (dBuV)	CORRECTION FACTOR (dB/m)
1	3775.66	44.0 PK	74.0	-30.0	1.00 V	72	44.3	-0.3
2	3775.66	34.3 AV	54.0	-19.7	1.00 V	72	34.6	-0.3
3	8704.88	46.5 PK	74.0	-27.5	1.50 V	109	37.3	9.2
4	8704.88	35.5 AV	54.0	-18.5	1.50 V	109	26.3	9.2
5	13333.95	34.1 AV	54.0	-19.9	1.50 V	177	20.5	13.6
6	13333.95	47.1 PK	74.0	-26.9	1.50 V	177	33.5	13.6

**REMARKS:**

1. Emission Level(dBuV/m) = Raw Value(dBuV) + Correction Factor(dB/m)
2. Correction Factor(dB/m) = Antenna Factor(dB/m) + Cable Factor(dB) – Pre-Amplifier Factor(dB)
3. The other emission levels were very low against the limit.
4. Margin value = Emission Level – Limit value

<b>CHANNEL</b>	TX Channel 3	<b>DETECTOR FUNCTION</b>	Peak (PK)
<b>FREQUENCY RANGE</b>	18GHz ~ 40GHz		Average (AV)

**ANTENNA POLARITY & TEST DISTANCE: HORIZONTAL AT 3 M**

NO.	FREQ. (MHz)	EMISSION LEVEL (dBuV/m)	LIMIT (dBuV/m)	MARGIN (dB)	ANTENNA HEIGHT (m)	TABLE ANGLE (Degree)	RAW VALUE (dBuV)	CORRECTION FACTOR (dB/m)
1	24193.87	46.5 PK	74.0	-27.5	1.00 H	169	65.4	-18.9
2	24193.87	35.9 AV	54.0	-18.1	1.00 H	169	54.8	-18.9
3	29602.77	45.0 PK	74.0	-29.0	1.00 H	219	63.6	-18.6
4	29602.77	37.6 AV	54.0	-16.4	1.00 H	219	56.2	-18.6
5	34491.70	45.7 PK	74.0	-28.3	1.50 H	280	64.9	-19.2
6	34491.70	36.4 AV	54.0	-17.6	1.50 H	280	55.6	-19.2

**ANTENNA POLARITY & TEST DISTANCE: VERTICAL AT 3 M**

NO.	FREQ. (MHz)	EMISSION LEVEL (dBuV/m)	LIMIT (dBuV/m)	MARGIN (dB)	ANTENNA HEIGHT (m)	TABLE ANGLE (Degree)	RAW VALUE (dBuV)	CORRECTION FACTOR (dB/m)
1	21113.85	44.1 PK	74.0	-29.9	1.50 V	140	64.1	-20.0
2	21113.85	34.2 AV	54.0	-19.8	1.50 V	140	54.2	-20.0
3	27247.51	44.9 PK	74.0	-29.1	1.50 V	97	62.7	-17.8
4	27247.51	36.8 AV	54.0	-17.2	1.50 V	97	54.6	-17.8
5	31283.98	46.6 PK	74.0	-27.4	1.00 V	125	64.5	-17.9
6	31283.98	35.1 AV	54.0	-18.9	1.00 V	125	53.0	-17.9

**REMARKS:**

1. Emission Level(dBuV/m) = Raw Value(dBuV) + Correction Factor(dB/m)
2. Correction Factor(dB/m) = Antenna Factor(dB/m) + Cable Factor(dB) – Pre-Amplifier Factor(dB)
3. The other emission levels were very low against the limit.
4. Margin value = Emission Level – Limit value

<b>CHANNEL</b>	TX Channel 3	<b>DETECTOR FUNCTION</b>	Peak (PK)
<b>FREQUENCY RANGE</b>	40GHz ~ 200GHz		Average (AV)

**ANTENNA POLARITY & TEST DISTANCE: HORIZONTAL AT 3 M**

NO.	Frequency (GHz)	EIRP Level (dBm)	Reading Value (dBm)	Transmit Antenna Gain (dBi)	Power Density (pW/cm <sup>2</sup> )	Power Density Limit (pW/cm <sup>2</sup> )
1	48.46	-44.14	-68.14	24	0.034 PK	90
2	125.92	-34.66	-58.26	23.6	0.302 PK	90

**ANTENNA POLARITY & TEST DISTANCE: VERTICAL AT 3 M**

NO.	Frequency (GHz)	EIRP Level (dBm)	Reading Value (dBm)	Transmit Antenna Gain (dBi)	Power Density (pW/cm <sup>2</sup> )	Power Density Limit (pW/cm <sup>2</sup> )
1	48.72	-45.05	-69.05	24	0.028 PK	90
2	125.92	-34.73	-58.33	23.6	0.298 PK	90

**Below 1GHz Data:**

<b>CHANNEL</b>	TX Channel 1	<b>DETECTOR FUNCTION</b>	Quasi-Peak (QP)
<b>FREQUENCY RANGE</b>	9kHz ~ 1GHz		

**ANTENNA POLARITY & TEST DISTANCE: HORIZONTAL AT 3 M**

NO.	FREQ. (MHz)	EMISSION LEVEL (dBuV/m)	LIMIT (dBuV/m)	MARGIN (dB)	ANTENNA HEIGHT (m)	TABLE ANGLE (Degree)	RAW VALUE (dBuV)	CORRECTION FACTOR (dB/m)
1	33.09	35.0 QP	40.0	-5.0	1.82 H	360	44.0	-9.0
2	239.62	41.9 QP	46.0	-4.1	1.50 H	0	51.1	-9.2
3	575.72	41.4 QP	46.0	-4.6	2.00 H	360	41.8	-0.4
4	791.84	40.2 QP	46.0	-5.8	2.50 H	299	36.5	3.7
5	864.01	40.4 QP	46.0	-5.6	1.50 H	302	36.0	4.4
6	891.00	41.4 QP	46.0	-4.6	2.50 H	273	36.6	4.8

**REMARKS:**

1. Emission Level(dBuV/m) = Raw Value(dBuV) + Correction Factor(dB/m)
2. Correction Factor(dB/m) = Antenna Factor(dB/m) + Cable Factor(dB) – Pre-Amplifier Factor(dB)
3. The other emission levels were very low against the limit.
4. Margin value = Emission Level – Limit value

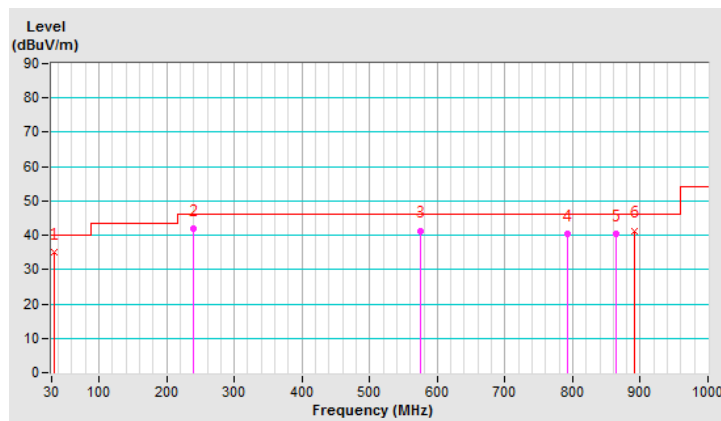

<b>CHANNEL</b>	TX Channel 1	<b>DETECTOR FUNCTION</b>	Quasi-Peak (QP)
<b>FREQUENCY RANGE</b>	9kHz ~ 1GHz		

**ANTENNA POLARITY & TEST DISTANCE: VERTICAL AT 3 M**

NO.	FREQ. (MHz)	EMISSION LEVEL (dBuV/m)	LIMIT (dBuV/m)	MARGIN (dB)	ANTENNA HEIGHT (m)	TABLE ANGLE (Degree)	RAW VALUE (dBuV)	CORRECTION FACTOR (dB/m)
1	30.59	35.9 QP	40.0	-4.1	1.01 V	264	45.0	-9.1
2	155.57	35.4 QP	43.5	-8.1	1.00 V	348	43.0	-7.6
3	503.41	39.9 QP	46.0	-6.1	1.00 V	161	41.8	-1.9
4	575.46	38.2 QP	46.0	-7.8	1.00 V	125	38.7	-0.5
5	791.67	38.3 QP	46.0	-7.7	2.00 V	283	34.7	3.6
6	891.18	40.6 QP	46.0	-5.4	1.50 V	360	35.8	4.8

**REMARKS:**

1. Emission Level(dBuV/m) = Raw Value(dBuV) + Correction Factor(dB/m)
2. Correction Factor(dB/m) = Antenna Factor(dB/m) + Cable Factor(dB) – Pre-Amplifier Factor(dB)
3. The other emission levels were very low against the limit.
4. Margin value = Emission Level – Limit value

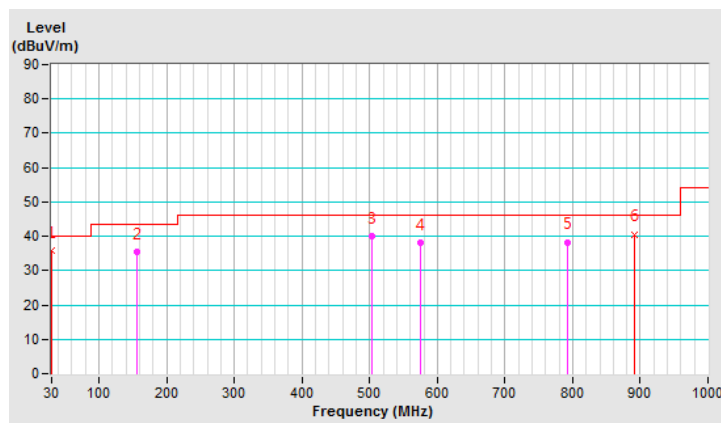

<b>CHANNEL</b>	TX Channel 2	<b>DETECTOR FUNCTION</b>	Quasi-Peak (QP)
<b>FREQUENCY RANGE</b>	9kHz ~ 1GHz		

**ANTENNA POLARITY & TEST DISTANCE: HORIZONTAL AT 3 M**

NO.	FREQ. (MHz)	EMISSION LEVEL (dBuV/m)	LIMIT (dBuV/m)	MARGIN (dB)	ANTENNA HEIGHT (m)	TABLE ANGLE (Degree)	RAW VALUE (dBuV)	CORRECTION FACTOR (dB/m)
1	33.09	35.2 QP	40.0	-4.8	1.56 H	287	44.2	-9.0
2	239.62	41.7 QP	46.0	-4.3	1.00 H	134	50.9	-9.2
3	575.72	41.5 QP	46.0	-4.5	1.56 H	226	41.9	-0.4
4	791.84	40.3 QP	46.0	-5.7	2.50 H	146	36.6	3.7
5	864.01	40.7 QP	46.0	-5.3	1.50 H	279	36.3	4.4
6	891.00	41.2 QP	46.0	-4.8	2.00 H	301	36.4	4.8

**REMARKS:**

1. Emission Level(dBuV/m) = Raw Value(dBuV) + Correction Factor(dB/m)
2. Correction Factor(dB/m) = Antenna Factor(dB/m) + Cable Factor(dB) – Pre-Amplifier Factor(dB)
3. The other emission levels were very low against the limit.
4. Margin value = Emission Level – Limit value

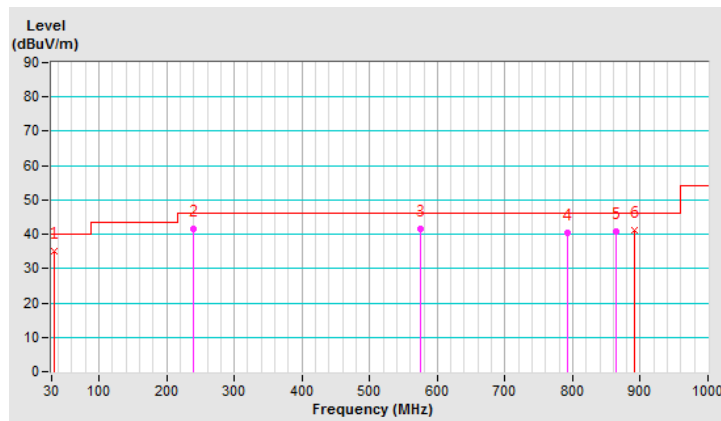

<b>CHANNEL</b>	TX Channel 2	<b>DETECTOR FUNCTION</b>	Quasi-Peak (QP)
<b>FREQUENCY RANGE</b>	9kHz ~ 1GHz		

**ANTENNA POLARITY & TEST DISTANCE: VERTICAL AT 3 M**

NO.	FREQ. (MHz)	EMISSION LEVEL (dBuV/m)	LIMIT (dBuV/m)	MARGIN (dB)	ANTENNA HEIGHT (m)	TABLE ANGLE (Degree)	RAW VALUE (dBuV)	CORRECTION FACTOR (dB/m)
1	30.59	35.8 QP	40.0	-4.2	1.00 V	115	44.9	-9.1
2	155.57	36.3 QP	43.5	-7.2	1.00 V	264	43.9	-7.6
3	503.41	40.2 QP	46.0	-5.8	1.00 V	183	42.1	-1.9
4	575.45	38.4 QP	46.0	-7.6	1.00 V	261	38.9	-0.5
5	791.67	38.5 QP	46.0	-7.5	1.50 V	318	34.9	3.6
6	891.18	40.4 QP	46.0	-5.6	1.50 V	115	35.6	4.8

**REMARKS:**

1. Emission Level(dBuV/m) = Raw Value(dBuV) + Correction Factor(dB/m)
2. Correction Factor(dB/m) = Antenna Factor(dB/m) + Cable Factor(dB) – Pre-Amplifier Factor(dB)
3. The other emission levels were very low against the limit.
4. Margin value = Emission Level – Limit value

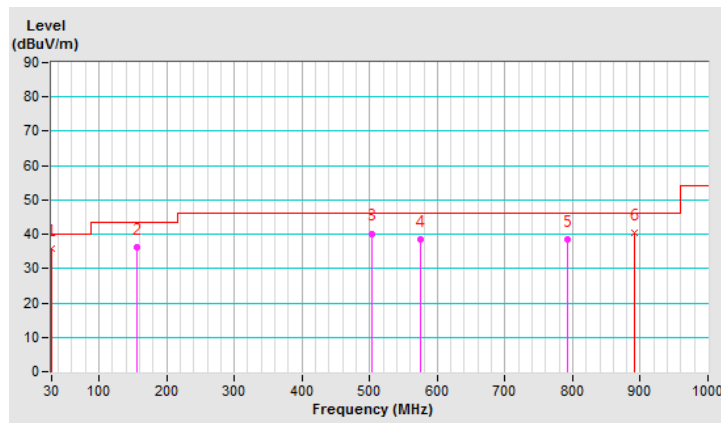



<b>CHANNEL</b>	TX Channel 3	<b>DETECTOR FUNCTION</b>	Quasi-Peak (QP)
<b>FREQUENCY RANGE</b>	9kHz ~ 1GHz		

**ANTENNA POLARITY & TEST DISTANCE: HORIZONTAL AT 3 M**

NO.	FREQ. (MHz)	EMISSION LEVEL (dBuV/m)	LIMIT (dBuV/m)	MARGIN (dB)	ANTENNA HEIGHT (m)	TABLE ANGLE (Degree)	RAW VALUE (dBuV)	CORRECTION FACTOR (dB/m)
1	33.10	35.3 QP	40.0	-4.7	1.53 H	192	44.3	-9.0
2	239.62	41.5 QP	46.0	-4.5	1.00 H	263	50.7	-9.2
3	575.72	41.6 QP	46.0	-4.4	1.50 H	177	42.0	-0.4
4	791.84	40.4 QP	46.0	-5.6	2.43 H	281	36.7	3.7
5	864.01	40.5 QP	46.0	-5.5	1.62 H	231	36.1	4.4
6	891.00	41.1 QP	46.0	-4.9	2.00 H	266	36.3	4.8

**REMARKS:**

1. Emission Level(dBuV/m) = Raw Value(dBuV) + Correction Factor(dB/m)
2. Correction Factor(dB/m) = Antenna Factor(dB/m) + Cable Factor(dB) – Pre-Amplifier Factor(dB)
3. The other emission levels were very low against the limit.
4. Margin value = Emission Level – Limit value

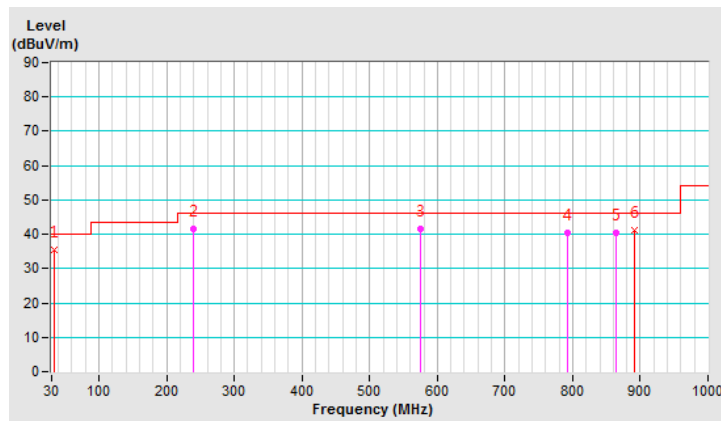

<b>CHANNEL</b>	TX Channel 3	<b>DETECTOR FUNCTION</b>	Quasi-Peak (QP)
<b>FREQUENCY RANGE</b>	9kHz ~ 1GHz		

**ANTENNA POLARITY & TEST DISTANCE: VERTICAL AT 3 M**

NO.	FREQ. (MHz)	EMISSION LEVEL (dBuV/m)	LIMIT (dBuV/m)	MARGIN (dB)	ANTENNA HEIGHT (m)	TABLE ANGLE (Degree)	RAW VALUE (dBuV)	CORRECTION FACTOR (dB/m)
1	30.59	35.8 QP	40.0	-4.2	1.00 V	138	44.9	-9.1
2	155.56	35.6 QP	43.5	-7.9	1.00 V	131	43.2	-7.6
3	503.40	40.3 QP	46.0	-5.7	1.00 V	223	42.2	-1.9
4	575.46	38.4 QP	46.0	-7.6	1.00 V	302	38.9	-0.5
5	791.67	38.5 QP	46.0	-7.5	1.50 V	301	34.9	3.6
6	891.18	40.7 QP	46.0	-5.3	1.50 V	112	35.9	4.8

**REMARKS:**

1. Emission Level(dBuV/m) = Raw Value(dBuV) + Correction Factor(dB/m)
2. Correction Factor(dB/m) = Antenna Factor(dB/m) + Cable Factor(dB) – Pre-Amplifier Factor(dB)
3. The other emission levels were very low against the limit.
4. Margin value = Emission Level – Limit value

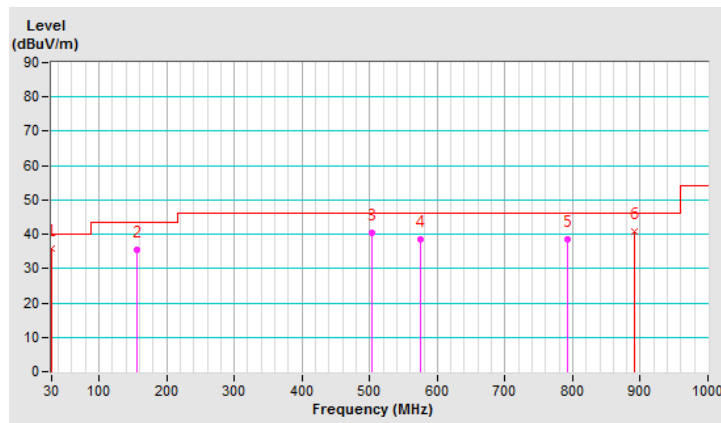

#### 4.1.8 Test Results (HRP mode)

##### Channel Plan A

##### Above 1GHz Data:

<b>CHANNEL</b>	TX Channel 1	<b>DETECTOR FUNCTION</b>	Peak (PK)
<b>FREQUENCY RANGE</b>	1GHz ~ 18GHz		Average (AV)

#### ANTENNA POLARITY & TEST DISTANCE: HORIZONTAL AT 3 M

NO.	FREQ. (MHz)	EMISSION LEVEL (dBuV/m)	LIMIT (dBuV/m)	MARGIN (dB)	ANTENNA HEIGHT (m)	TABLE ANGLE (Degree)	RAW VALUE (dBuV)	CORRECTION FACTOR (dB/m)
1	2836.63	43.5 PK	74.0	-30.5	1.50 H	205	45.6	-2.1
2	2836.63	36.6 AV	54.0	-17.4	1.50 H	205	38.7	-2.1
3	10542.13	46.9 PK	74.0	-27.1	1.00 H	311	34.7	12.2
4	10542.13	37.3 AV	54.0	-16.7	1.00 H	311	25.1	12.2
5	14710.53	57.7 PK	74.0	-16.3	1.00 H	245	42.0	15.7
6	14710.53	48.3 AV	54.0	-5.7	1.00 H	245	32.6	15.7

#### ANTENNA POLARITY & TEST DISTANCE: VERTICAL AT 3 M

NO.	FREQ. (MHz)	EMISSION LEVEL (dBuV/m)	LIMIT (dBuV/m)	MARGIN (dB)	ANTENNA HEIGHT (m)	TABLE ANGLE (Degree)	RAW VALUE (dBuV)	CORRECTION FACTOR (dB/m)
1	3773.79	44.2 PK	74.0	-29.8	1.00 V	72	44.5	-0.3
2	3773.79	34.2 AV	54.0	-19.8	1.00 V	72	34.5	-0.3
3	8706.24	48.4 PK	74.0	-25.6	1.50 V	134	39.2	9.2
4	8706.24	35.9 AV	54.0	-18.1	1.50 V	134	26.7	9.2
5	13333.87	48.2 PK	74.0	-25.8	1.50 V	211	34.6	13.6
6	13333.87	34.5 AV	54.0	-19.5	1.50 V	211	20.9	13.6

#### REMARKS:

1. Emission Level(dBuV/m) = Raw Value(dBuV) + Correction Factor(dB/m)
2. Correction Factor(dB/m) = Antenna Factor(dB/m) + Cable Factor(dB) – Pre-Amplifier Factor(dB)
3. The other emission levels were very low against the limit.
4. Margin value = Emission Level – Limit value

<b>CHANNEL</b>	TX Channel 1	<b>DETECTOR FUNCTION</b>	Peak (PK)
<b>FREQUENCY RANGE</b>	18GHz ~ 40GHz		Average (AV)

**ANTENNA POLARITY & TEST DISTANCE: HORIZONTAL AT 3 M**

NO.	FREQ. (MHz)	EMISSION LEVEL (dBuV/m)	LIMIT (dBuV/m)	MARGIN (dB)	ANTENNA HEIGHT (m)	TABLE ANGLE (Degree)	RAW VALUE (dBuV)	CORRECTION FACTOR (dB/m)
1	24193.60	45.1 PK	74.0	-28.9	1.50 H	94	64.0	-18.9
2	24193.60	34.5 AV	54.0	-19.5	1.50 H	94	53.4	-18.9
3	29599.72	43.4 PK	74.0	-30.6	1.00 H	284	62.0	-18.6
4	29599.72	37.2 AV	54.0	-16.8	1.00 H	284	55.8	-18.6
5	34490.57	45.5 PK	74.0	-28.5	1.50 H	251	64.7	-19.2
6	34490.57	36.1 AV	54.0	-17.9	1.50 H	251	55.3	-19.2

**ANTENNA POLARITY & TEST DISTANCE: VERTICAL AT 3 M**

NO.	FREQ. (MHz)	EMISSION LEVEL (dBuV/m)	LIMIT (dBuV/m)	MARGIN (dB)	ANTENNA HEIGHT (m)	TABLE ANGLE (Degree)	RAW VALUE (dBuV)	CORRECTION FACTOR (dB/m)
1	21113.84	45.8 PK	74.0	-28.2	1.00 V	217	65.8	-20.0
2	21113.84	35.4 AV	54.0	-18.6	1.00 V	217	55.4	-20.0
3	27246.06	44.2 PK	74.0	-29.8	1.50 V	25	62.0	-17.8
4	27246.06	36.9 AV	54.0	-17.1	1.50 V	25	54.7	-17.8
5	31280.91	46.4 PK	74.0	-27.6	1.00 V	148	64.3	-17.9
6	31280.91	35.9 AV	54.0	-18.1	1.00 V	148	53.8	-17.9

**REMARKS:**

1. Emission Level(dBuV/m) = Raw Value(dBuV) + Correction Factor(dB/m)
2. Correction Factor(dB/m) = Antenna Factor(dB/m) + Cable Factor(dB) – Pre-Amplifier Factor(dB)
3. The other emission levels were very low against the limit.
4. Margin value = Emission Level – Limit value

<b>CHANNEL</b>	TX Channel 1	<b>DETECTOR FUNCTION</b>	Peak (PK)
<b>FREQUENCY RANGE</b>	40GHz ~ 200GHz		Average (AV)

**ANTENNA POLARITY & TEST DISTANCE: HORIZONTAL AT 3 M**

NO.	Frequency (GHz)	EIRP Level (dBm)	Reading Value (dBm)	Transmit Antenna Gain (dBi)	Power Density (pW/cm <sup>2</sup> )	Power Density Limit (pW/cm <sup>2</sup> )
1	43.24	-45.23	-69.23	24	0.027 PK	90
2	120.96	-34.74	-58.34	23.6	0.297 PK	90

**ANTENNA POLARITY & TEST DISTANCE: VERTICAL AT 3 M**

NO.	Frequency (GHz)	EIRP Level (dBm)	Reading Value (dBm)	Transmit Antenna Gain (dBi)	Power Density (pW/cm <sup>2</sup> )	Power Density Limit (pW/cm <sup>2</sup> )
1	43.03	-45.47	-69.47	24	0.025 PK	90
2	120.96	-35.03	-58.63	23.6	0.278 PK	90

<b>CHANNEL</b>	TX Channel 2	<b>DETECTOR FUNCTION</b>	Peak (PK)
<b>FREQUENCY RANGE</b>	1GHz ~ 18GHz		Average (AV)

**ANTENNA POLARITY & TEST DISTANCE: HORIZONTAL AT 3 M**

NO.	FREQ. (MHz)	EMISSION LEVEL (dBuV/m)	LIMIT (dBuV/m)	MARGIN (dB)	ANTENNA HEIGHT (m)	TABLE ANGLE (Degree)	RAW VALUE (dBuV)	CORRECTION FACTOR (dB/m)
1	2833.47	43.9 PK	74.0	-30.1	1.50 H	184	46.0	-2.1
2	2833.47	36.2 AV	54.0	-17.8	1.50 H	184	38.3	-2.1
3	10525.26	47.2 PK	74.0	-26.8	1.50 H	285	35.0	12.2
4	10525.26	36.8 AV	54.0	-17.2	1.50 H	285	24.6	12.2
5	14711.62	57.6 PK	74.0	-16.4	1.00 H	238	41.9	15.7
6	14711.62	47.8 AV	54.0	-6.2	1.00 H	238	32.1	15.7

**ANTENNA POLARITY & TEST DISTANCE: VERTICAL AT 3 M**

NO.	FREQ. (MHz)	EMISSION LEVEL (dBuV/m)	LIMIT (dBuV/m)	MARGIN (dB)	ANTENNA HEIGHT (m)	TABLE ANGLE (Degree)	RAW VALUE (dBuV)	CORRECTION FACTOR (dB/m)
1	3774.35	44.5 PK	74.0	-29.5	1.00 V	95	44.8	-0.3
2	3774.35	33.8 AV	54.0	-20.2	1.00 V	95	34.1	-0.3
3	8705.57	48.1 PK	74.0	-25.9	1.50 V	127	38.9	9.2
4	8705.57	35.6 AV	54.0	-18.4	1.50 V	127	26.4	9.2
5	13333.10	35.2 AV	54.0	-18.8	1.50 V	199	21.6	13.6
6	13333.10	48.4 PK	74.0	-25.6	1.50 V	199	34.8	13.6

**REMARKS:**

1. Emission Level(dBuV/m) = Raw Value(dBuV) + Correction Factor(dB/m)
2. Correction Factor(dB/m) = Antenna Factor(dB/m) + Cable Factor(dB) – Pre-Amplifier Factor(dB)
3. The other emission levels were very low against the limit.
4. Margin value = Emission Level – Limit value

<b>CHANNEL</b>	TX Channel 2	<b>DETECTOR FUNCTION</b>	Peak (PK)
<b>FREQUENCY RANGE</b>	18GHz ~ 40GHz		Average (AV)

**ANTENNA POLARITY & TEST DISTANCE: HORIZONTAL AT 3 M**

NO.	FREQ. (MHz)	EMISSION LEVEL (dBuV/m)	LIMIT (dBuV/m)	MARGIN (dB)	ANTENNA HEIGHT (m)	TABLE ANGLE (Degree)	RAW VALUE (dBuV)	CORRECTION FACTOR (dB/m)
1	24192.93	45.3 PK	74.0	-28.7	1.50 H	107	64.2	-18.9
2	24192.93	34.3 AV	54.0	-19.7	1.50 H	107	53.2	-18.9
3	29599.04	43.5 PK	74.0	-30.5	1.00 H	277	62.1	-18.6
4	29599.04	37.1 AV	54.0	-16.9	1.00 H	277	55.7	-18.6
5	34490.76	45.8 PK	74.0	-28.2	1.50 H	274	65.0	-19.2
6	34490.76	36.2 AV	54.0	-17.8	1.50 H	274	55.4	-19.2

**ANTENNA POLARITY & TEST DISTANCE: VERTICAL AT 3 M**

NO.	FREQ. (MHz)	EMISSION LEVEL (dBuV/m)	LIMIT (dBuV/m)	MARGIN (dB)	ANTENNA HEIGHT (m)	TABLE ANGLE (Degree)	RAW VALUE (dBuV)	CORRECTION FACTOR (dB/m)
1	21113.40	45.4 PK	74.0	-28.6	1.00 V	208	65.4	-20.0
2	21113.40	34.9 AV	54.0	-19.1	1.00 V	208	54.9	-20.0
3	27246.69	44.1 PK	74.0	-29.9	1.50 V	38	61.9	-17.8
4	27246.69	36.6 AV	54.0	-17.4	1.50 V	38	54.4	-17.8
5	31281.29	46.2 PK	74.0	-27.8	1.00 V	133	64.1	-17.9
6	31281.29	35.7 AV	54.0	-18.3	1.00 V	133	53.6	-17.9

**REMARKS:**

1. Emission Level(dBuV/m) = Raw Value(dBuV) + Correction Factor(dB/m)
2. Correction Factor(dB/m) = Antenna Factor(dB/m) + Cable Factor(dB) – Pre-Amplifier Factor(dB)
3. The other emission levels were very low against the limit.
4. Margin value = Emission Level – Limit value

<b>CHANNEL</b>	TX Channel 2	<b>DETECTOR FUNCTION</b>	Peak (PK)
<b>FREQUENCY RANGE</b>	40GHz ~ 200GHz		Average (AV)

**ANTENNA POLARITY & TEST DISTANCE: HORIZONTAL AT 3 M**

NO.	Frequency (GHz)	EIRP Level (dBm)	Reading Value (dBm)	Transmit Antenna Gain (dBi)	Power Density (pW/cm <sup>2</sup> )	Power Density Limit (pW/cm <sup>2</sup> )
1	48.56	-44.31	-68.31	24	0.033 PK	90
2	125.28	-35.07	-58.67	23.6	0.275 PK	90

**ANTENNA POLARITY & TEST DISTANCE: VERTICAL AT 3 M**

NO.	Frequency (GHz)	EIRP Level (dBm)	Reading Value (dBm)	Transmit Antenna Gain (dBi)	Power Density (pW/cm <sup>2</sup> )	Power Density Limit (pW/cm <sup>2</sup> )
1	48.13	-45.12	-69.12	24	0.027 PK	90
2	125.28	-35.29	-58.89	23.6	0.262 PK	90



Below 1GHz Data:

<b>CHANNEL</b>	TX Channel 1	<b>DETECTOR FUNCTION</b>	Quasi-Peak (QP)
<b>FREQUENCY RANGE</b>	9kHz ~ 1GHz		

ANTENNA POLARITY & TEST DISTANCE: HORIZONTAL AT 3 M								
NO.	FREQ. (MHz)	EMISSION LEVEL (dBuV/m)	LIMIT (dBuV/m)	MARGIN (dB)	ANTENNA HEIGHT (m)	TABLE ANGLE (Degree)	RAW VALUE (dBuV)	CORRECTION FACTOR (dB/m)
1	32.82	34.8 QP	40.0	-5.2	1.81 H	360	43.8	-9.0
2	186.92	37.0 QP	43.5	-6.5	1.50 H	92	47.0	-10.0
3	238.55	38.0 QP	46.0	-8.0	1.50 H	17	47.3	-9.3
4	575.62	41.6 QP	46.0	-4.4	1.50 H	14	42.1	-0.5
5	791.93	41.9 QP	46.0	-4.1	1.34 H	288	38.2	3.7
<b>6</b>	<b>891.26</b>	<b>42.4 QP</b>	<b>46.0</b>	<b>-3.6</b>	<b>1.01 H</b>	<b>57</b>	<b>37.6</b>	<b>4.8</b>

REMARKS:

1. Emission Level(dBuV/m) = Raw Value(dBuV) + Correction Factor(dB/m)
2. Correction Factor(dB/m) = Antenna Factor(dB/m) + Cable Factor(dB) – Pre-Amplifier Factor(dB)
3. The other emission levels were very low against the limit.
4. Margin value = Emission Level – Limit value

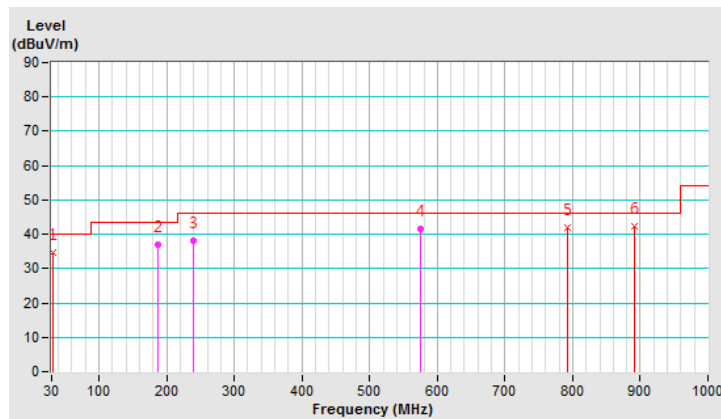

<b>CHANNEL</b>	TX Channel 1	<b>DETECTOR FUNCTION</b>	Quasi-Peak (QP)
<b>FREQUENCY RANGE</b>	9kHz ~ 1GHz		

**ANTENNA POLARITY & TEST DISTANCE: VERTICAL AT 3 M**

NO.	FREQ. (MHz)	EMISSION LEVEL (dBuV/m)	LIMIT (dBuV/m)	MARGIN (dB)	ANTENNA HEIGHT (m)	TABLE ANGLE (Degree)	RAW VALUE (dBuV)	CORRECTION FACTOR (dB/m)
1	32.19	34.7 QP	40.0	-5.3	1.01 V	240	43.7	-9.0
2	395.76	38.3 QP	46.0	-7.7	1.00 V	325	42.9	-4.6
3	431.60	39.3 QP	46.0	-6.7	2.00 V	295	42.5	-3.2
4	575.36	41.5 QP	46.0	-4.5	2.00 V	208	42.0	-0.5
5	791.33	39.9 QP	46.0	-6.1	2.00 V	324	36.3	3.6
6	890.97	39.8 QP	46.0	-6.2	2.75 V	265	35.0	4.8

**REMARKS:**

1. Emission Level(dBuV/m) = Raw Value(dBuV) + Correction Factor(dB/m)
2. Correction Factor(dB/m) = Antenna Factor(dB/m) + Cable Factor(dB) – Pre-Amplifier Factor(dB)
3. The other emission levels were very low against the limit.
4. Margin value = Emission Level – Limit value

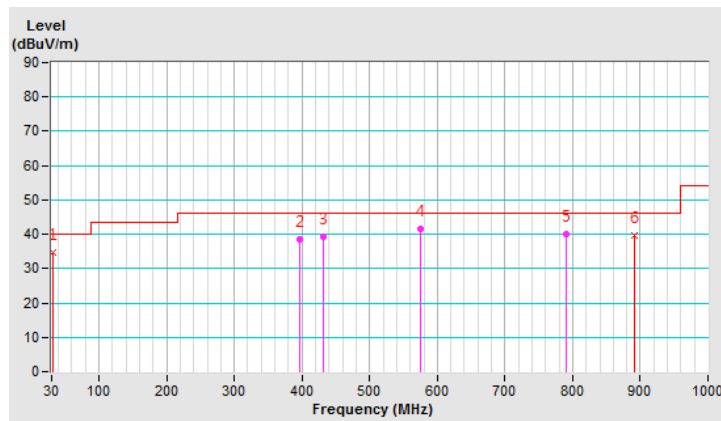

<b>CHANNEL</b>	TX Channel 2	<b>DETECTOR FUNCTION</b>	Quasi-Peak (QP)
<b>FREQUENCY RANGE</b>	9kHz ~ 1GHz		

**ANTENNA POLARITY & TEST DISTANCE: HORIZONTAL AT 3 M**

NO.	FREQ. (MHz)	EMISSION LEVEL (dBuV/m)	LIMIT (dBuV/m)	MARGIN (dB)	ANTENNA HEIGHT (m)	TABLE ANGLE (Degree)	RAW VALUE (dBuV)	CORRECTION FACTOR (dB/m)
1	32.82	34.6 QP	40.0	-5.4	1.80 H	354	43.6	-9.0
2	186.92	37.2 QP	43.5	-6.3	1.51 H	184	47.2	-10.0
3	238.54	38.1 QP	46.0	-7.9	2.00 H	231	47.4	-9.3
4	575.62	41.4 QP	46.0	-4.6	1.50 H	264	41.9	-0.5
5	791.93	41.8 QP	46.0	-4.2	1.32 H	256	38.1	3.7
6	891.26	42.2 QP	46.0	-3.8	1.00 H	261	37.4	4.8

**REMARKS:**

1. Emission Level(dBuV/m) = Raw Value(dBuV) + Correction Factor(dB/m)
2. Correction Factor(dB/m) = Antenna Factor(dB/m) + Cable Factor(dB) – Pre-Amplifier Factor(dB)
3. The other emission levels were very low against the limit.
4. Margin value = Emission Level – Limit value

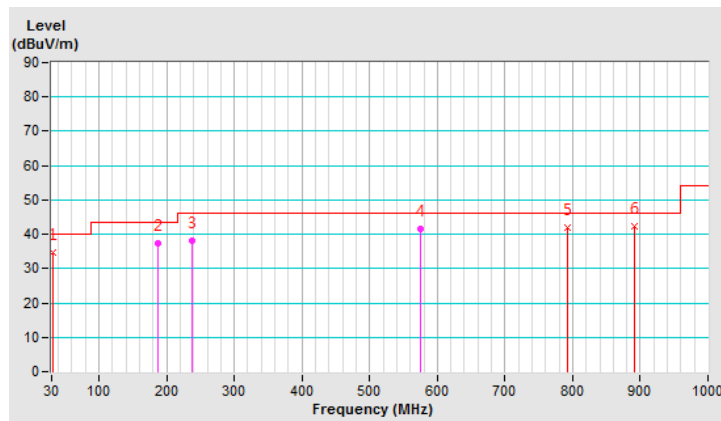

<b>CHANNEL</b>	TX Channel 2	<b>DETECTOR FUNCTION</b>	Quasi-Peak (QP)
<b>FREQUENCY RANGE</b>	9kHz ~ 1GHz		

**ANTENNA POLARITY & TEST DISTANCE: VERTICAL AT 3 M**

NO.	FREQ. (MHz)	EMISSION LEVEL (dBuV/m)	LIMIT (dBuV/m)	MARGIN (dB)	ANTENNA HEIGHT (m)	TABLE ANGLE (Degree)	RAW VALUE (dBuV)	CORRECTION FACTOR (dB/m)
1	32.19	34.6 QP	40.0	-5.4	1.00 V	157	43.6	-9.0
2	395.76	38.5 QP	46.0	-7.5	1.00 V	119	43.1	-4.6
3	431.60	39.2 QP	46.0	-6.8	1.50 V	318	42.4	-3.2
4	575.36	41.4 QP	46.0	-4.6	1.56 V	279	41.9	-0.5
5	791.33	40.0 QP	46.0	-6.0	1.50 V	266	36.4	3.6
6	890.97	39.7 QP	46.0	-6.3	2.64 V	209	34.9	4.8

**REMARKS:**

1. Emission Level(dBuV/m) = Raw Value(dBuV) + Correction Factor(dB/m)
2. Correction Factor(dB/m) = Antenna Factor(dB/m) + Cable Factor(dB) – Pre-Amplifier Factor(dB)
3. The other emission levels were very low against the limit.
4. Margin value = Emission Level – Limit value

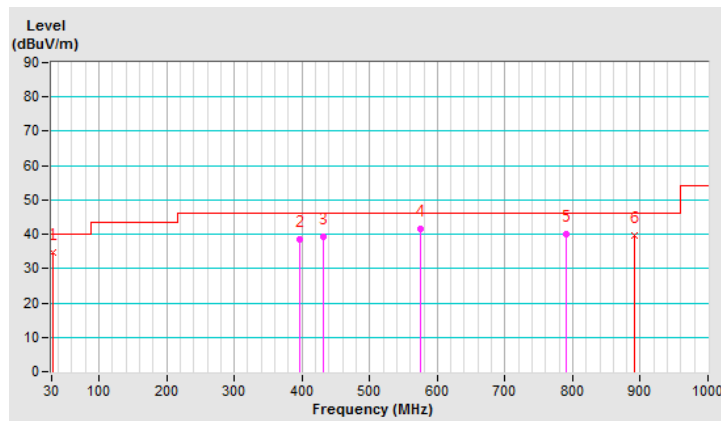

## 4.2 Conducted Emission Measurement

### 4.2.1 Limits of Conducted Emission Measurement

Frequency (MHz)	Conducted Limit (dBuV)	
	Quasi-peak	Average
0.15 - 0.5	66 - 56	56 - 46
0.50 - 5.0	56	46
5.0 - 30.0	60	50

Note: 1. The lower limit shall apply at the transition frequencies.

2. The limit decreases in line with the logarithm of the frequency in the range of 0.15 to 0.50MHz.

### 4.2.2 Test Instruments

DESCRIPTION & MANUFACTURER	MODEL NO.	SERIAL NO.	CALIBRATED DATE	CALIBRATED UNTIL
Test Receiver R&S	ESCS 30	847124/029	Nov. 01, 2017	Oct. 31, 2018
Line-Impedance Stabilization Network (for EUT) R&S	ESH3-Z5	848773/004	Nov. 15, 2017	Nov. 14, 2018
Line-Impedance Stabilization Network (for Peripheral) R&S	ENV216	100072	June 04, 2018	June 03, 2019
50 ohms Terminator	N/A	EMC-02	Sep. 22, 2017	Sep. 21, 2018
RF Cable	5D-FB	COCCAB-001	Sep. 29, 2017	Sep. 28, 2018
Fixed attenuator EMCI	STI02-2200-10	003	Mar. 16, 2018	Mar. 15, 2019
Software BVADT	BVADT_Cond_ V7.3.7.4	NA	NA	NA

**Note:**

1. The calibration interval of the above test instruments are 12 months and the calibrations are traceable to NML/ROC and NIST/USA.
2. The test was performed in Conduction 1.
- 3 Tested Date: Aug. 28, 2018

#### 4.2.3 Test Procedures

- The EUT was placed 0.4 meters from the conducting wall of the shielded room with EUT being connected to the power mains through a line impedance stabilization network (LISN). Other support units were connected to the power mains through another LISN. The two LISNs provide 50 ohm/ 50uH of coupling impedance for the measuring instrument.
- Both lines of the power mains connected to the EUT were checked for maximum conducted interference.
- The frequency range from 150kHz to 30MHz was searched. Emission levels under (Limit - 20dB) was not recorded.

**NOTE:** The resolution bandwidth and video bandwidth of test receiver is 9kHz for quasi-peak detection (QP) and average detection (AV) at frequency 0.15MHz-30MHz.

#### 4.2.4 Deviation from Test Standard

No deviation.

#### 4.2.5 Test Setup

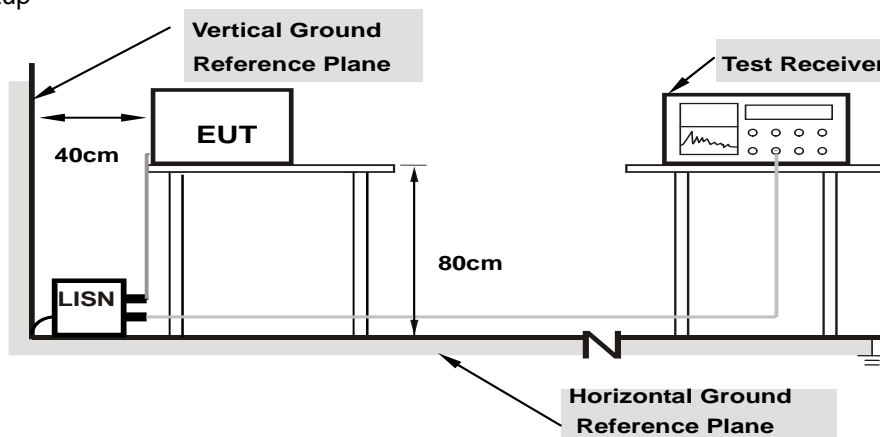

**Note:** 1.Support units were connected to second LISN.

For the actual test configuration, please refer to the attached file (Test Setup Photo).

#### 4.2.6 EUT Operating Conditions

Same as 4.1.6.

#### 4.2.7 Test Results

Phase	Line (L)	Detector Function	Quasi-Peak (QP) / Average (AV)
-------	----------	-------------------	--------------------------------

No	Freq. [MHz]	Corr.	Reading Value		Emission Level		Limit		Margin	
		Factor (dB)	[dB (uV)]		[dB (uV)]		[dB (uV)]		(dB)	
		Q.P.	AV.	Q.P.	AV.	Q.P.	AV.	Q.P.	AV.	
1	0.54356	10.13	31.54	22.63	41.67	32.76	56.00	46.00	-14.33	-13.24
2	0.87266	10.16	22.08	12.70	32.24	22.86	56.00	46.00	-23.76	-23.14
3	1.86328	10.21	24.12	15.79	34.33	26.00	56.00	46.00	-21.67	-20.00
4	6.80859	10.51	23.67	12.19	34.18	22.70	60.00	50.00	-25.82	-27.30
5	13.83203	10.98	16.83	9.68	27.81	20.66	60.00	50.00	-32.19	-29.34
6	24.25000	11.46	8.55	1.00	20.01	12.46	60.00	50.00	-39.99	-37.54

#### REMARKS:

1. Q.P. and AV. are abbreviations of quasi-peak and average individually.
2. The emission levels of other frequencies were very low against the limit.
3. Margin value = Emission level - Limit value
4. Correction factor = Insertion loss + Cable loss
5. Emission Level = Correction Factor + Reading Value.

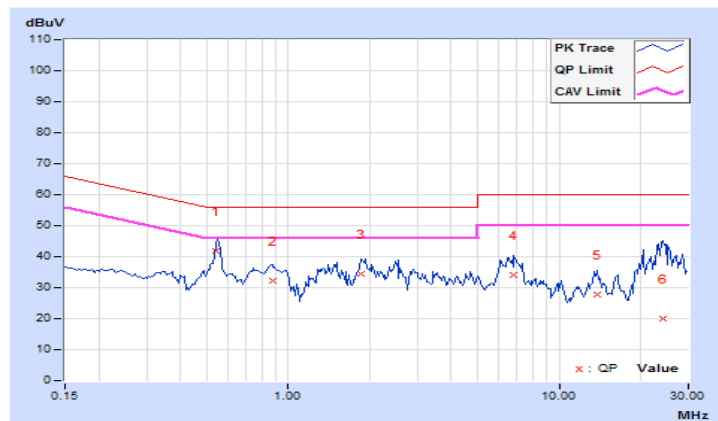

Phase	Neutral (N)	Detector Function	Quasi-Peak (QP) / Average (AV)
-------	-------------	-------------------	--------------------------------

No	Freq. [MHz]	Corr.	Reading Value		Emission Level		Limit		Margin	
		Factor	[dB (uV)]		[dB (uV)]		[dB (uV)]		(dB)	
		(dB)	Q.P.	AV.	Q.P.	AV.	Q.P.	AV.	Q.P.	AV.
1	0.15000	9.95	35.10	20.48	45.05	30.43	66.00	56.00	-20.95	-25.57
2	0.53672	10.02	31.56	22.42	41.58	32.44	56.00	46.00	-14.42	-13.56
3	1.63672	10.08	23.40	15.05	33.48	25.13	56.00	46.00	-22.52	-20.87
4	6.19922	10.32	18.15	11.28	28.47	21.60	60.00	50.00	-31.53	-28.40
5	16.46484	10.95	16.01	11.77	26.96	22.72	60.00	50.00	-33.04	-27.28
6	25.87109	11.24	11.68	4.91	22.92	16.15	60.00	50.00	-37.08	-33.85

#### REMARKS:

1. Q.P. and AV. are abbreviations of quasi-peak and average individually.
2. The emission levels of other frequencies were very low against the limit.
3. Margin value = Emission level - Limit value
4. Correction factor = Insertion loss + Cable loss
5. Emission Level = Correction Factor + Reading Value.

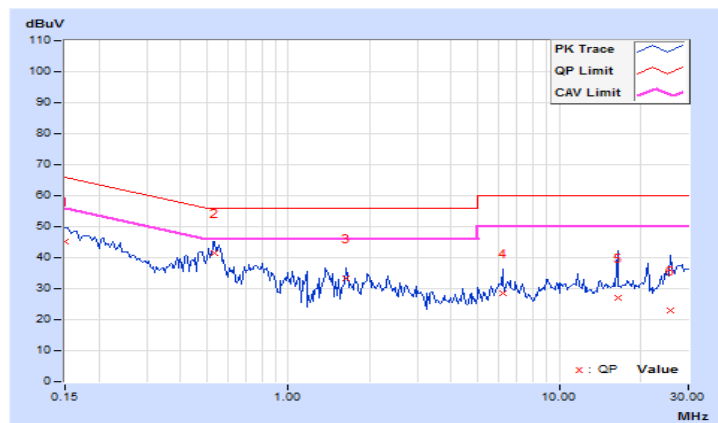



### 4.3 6dB Bandwidth Measurement

#### 4.3.1 Limits of 6dB Bandwidth Measurement

None: For reporting purposes only.

#### 4.3.2 Test Setup

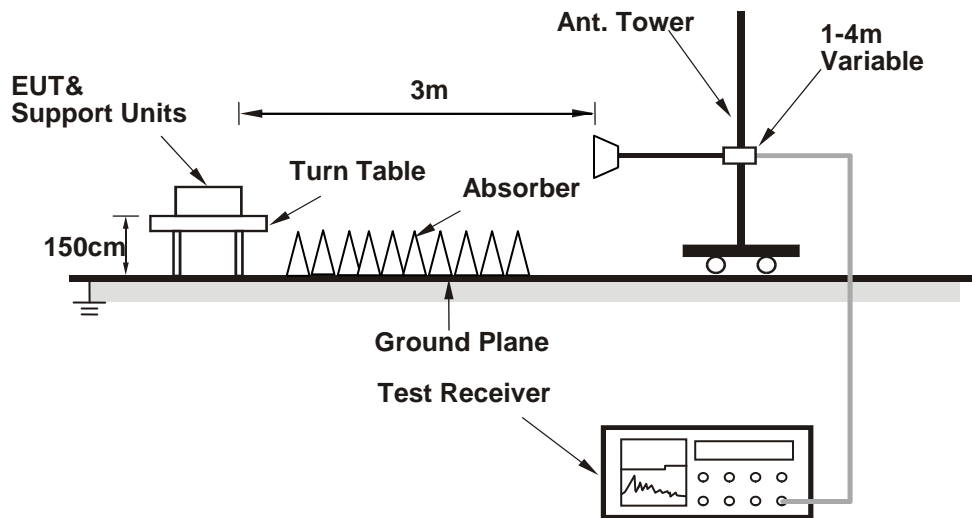

#### 4.3.3 Test Instruments

Refer to section 4.1.2 to get information of above instrument.

#### 4.3.4 Test Procedure

The spectrum analyzer and external mixer are set up to measure the radiated output of the transmitter.

#### 4.3.5 Deviation from Test Standard

No deviation.

#### 4.3.6 EUT Operating Conditions

The software provided by client to enable the EUT under transmission condition continuously at lowest, middle and highest channel frequencies individually.

### 4.3.7 Test Result (LRP Mode)

#### Channel Plan A

Channel	Frequency (GHz)	6dB Bandwidth (MHz)
1	60.16	90.38
2	60.48	90.22
3	60.8	90.41

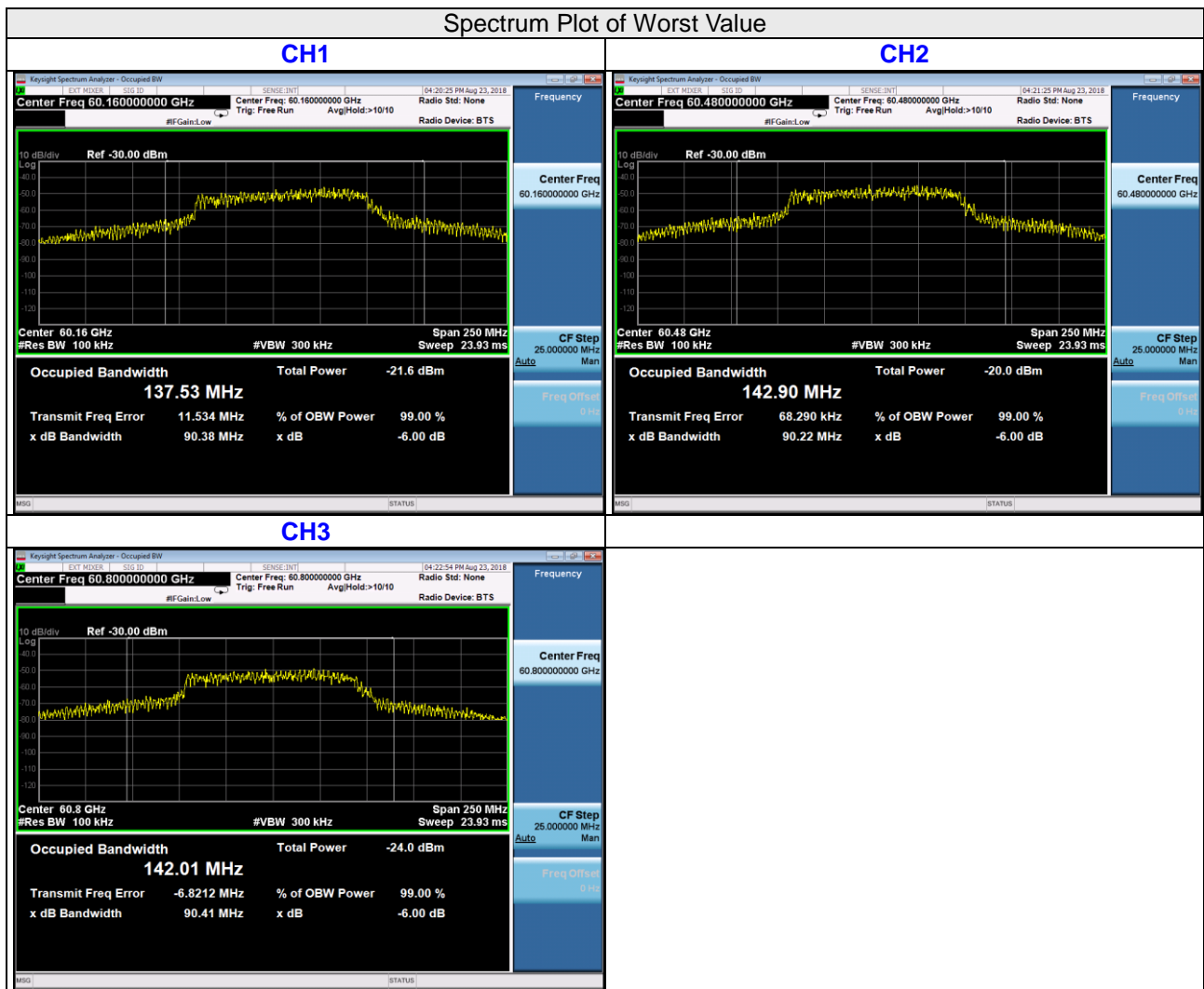

### Channel Plan B

Channel	Frequency (GHz)	6dB Bandwidth (MHz)
1	62.32	87.86
2	62.64	90.08
3	62.96	87.68

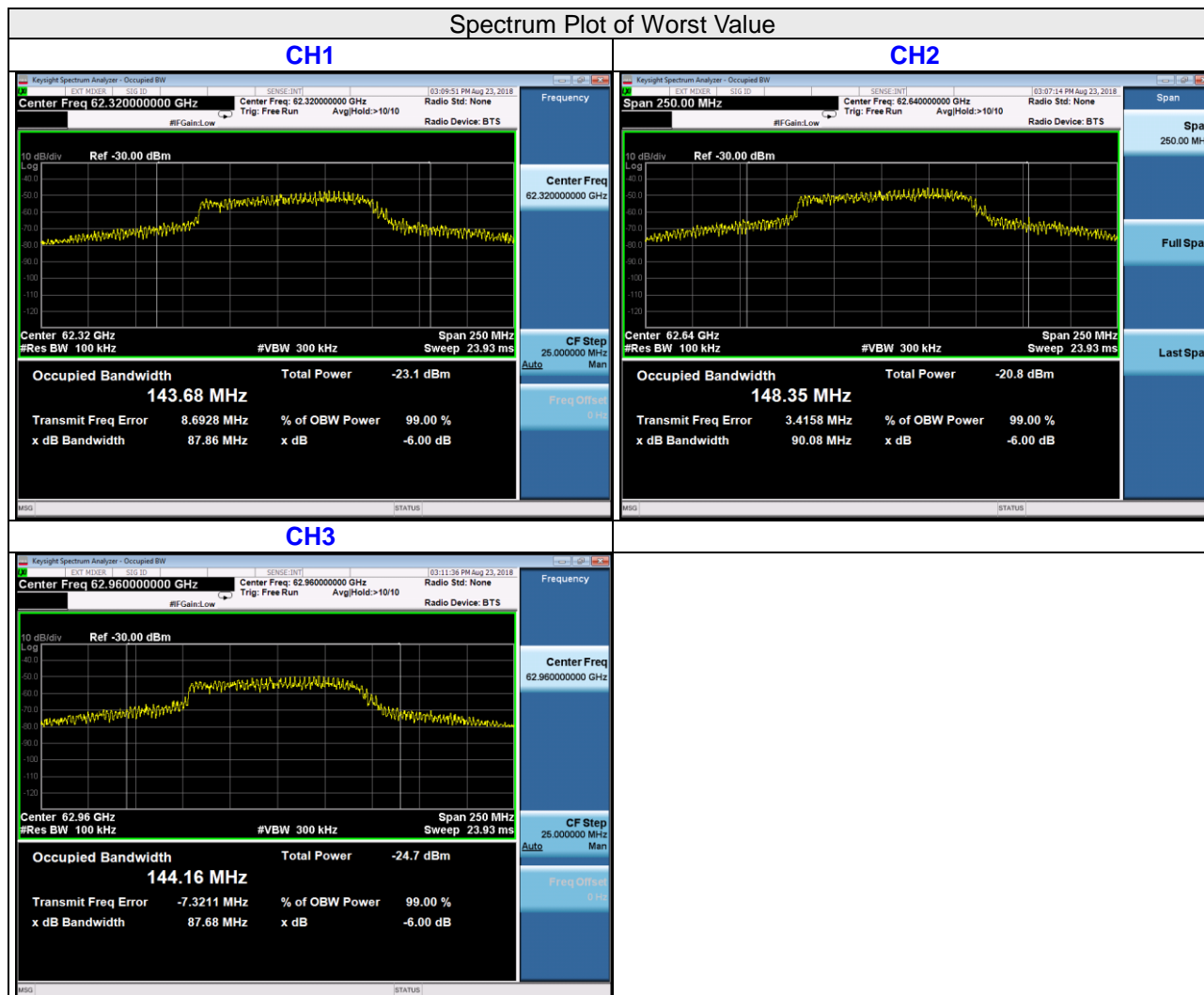

### 4.3.8 Test Result (HRP Mode)

Channel	Frequency (GHz)	6dB Bandwidth (MHz)
1	60.48	734.6
2	62.64	793.4

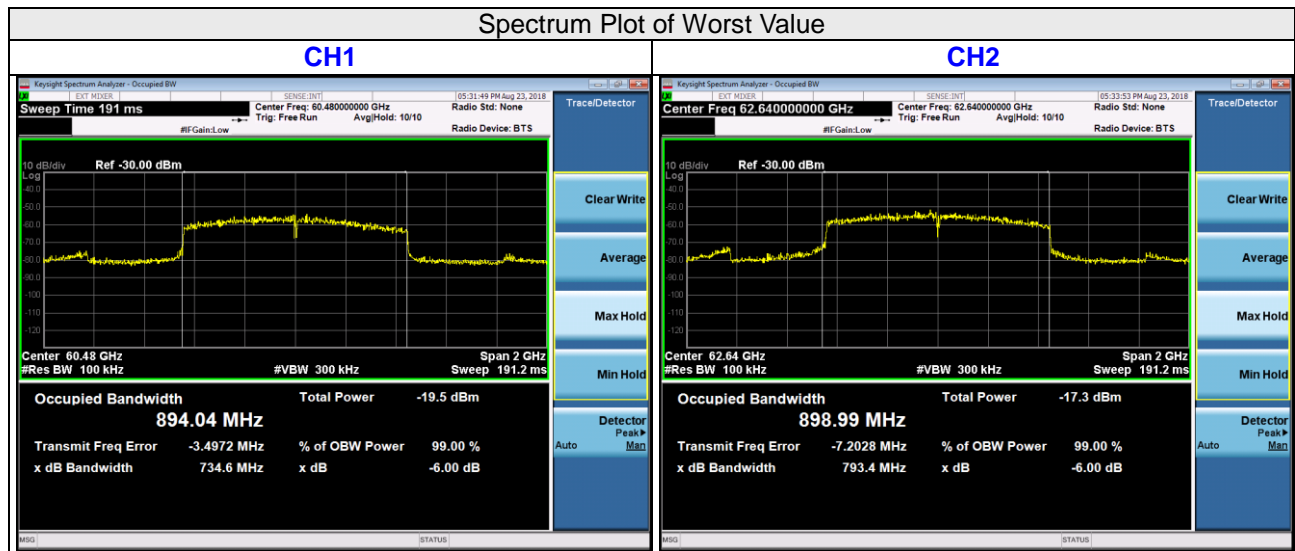

#### 4.4 Output Power Measurement

##### 4.4.1 Limits of Output Power Measurement

15.255 (c) & (e)

Output Power (EIRP)				
Applicable	Type		Peak Power	Average Power
V	Within the 57-71 GHz band ( Other than fixed field disturbance sensors and short-range devices)	Other than fixed point to point transmitters located outdoors	43dBm	40dBm
		Fixed point-to-point transmitters located outdoors	85dBm (*Note 1)	82dBm (*Note 2)
	Fixed field disturbance sensors (61-61.5GHz)	Occupy 500 MHz or less of bandwidth	43dBm (*Note 3)	40dBm (*Note 3)
	Fixed field disturbance sensors	Other than occupy 500 MHz or less of bandwidth and that are contained wholly within the frequency band 61.0-61.5 GHz	10dBm	-
	short-range devices for interactive motion sensing	-		

Note:

1. The average power of any emission shall not exceed 82 dBm, and shall be reduced by 2 dB for every dB that the antenna gain is less than 51 dBi.
2. The peak power of any emission shall not exceed 85 dBm, and shall be reduced by 2 dB for every dB that the antenna gain is less than 51 dBi.
3. In addition, the average power of any emission outside of the 61.0-61.5 GHz band, measured during the transmit interval, but still within the 57-71 GHz band, shall not exceed 10 dBm, and the peak power of any emission shall not exceed 13 dBm.

Peak Output Power (Conducted Power)			
Applicable	Type	6dB Bandwidth	Maximum Conducted Power
	Fixed field disturbance sensors (Exclude 61-61.5GHz)	-	$\leq 0.1\text{mW}$
V	Other	Other	500mW
V		Less than 100MHz	500mW x (B/100)

Note:

1. B is 6dB Bandwidth (measured with a 100kHz resolution bandwidth)
2. Peak transmitter output power shall be measured with an RF detector that has a detection bandwidth that encompasses the 57-64 GHz band and the has a video bandwidth of at least 10 MHz, or using an equivalent measurement method.
3. For purposes of demonstrating compliance with this paragraph (e), corrections to the transmitter output power may be made due to the antenna and circuit loss.

#### 4.4.2 Test Setup

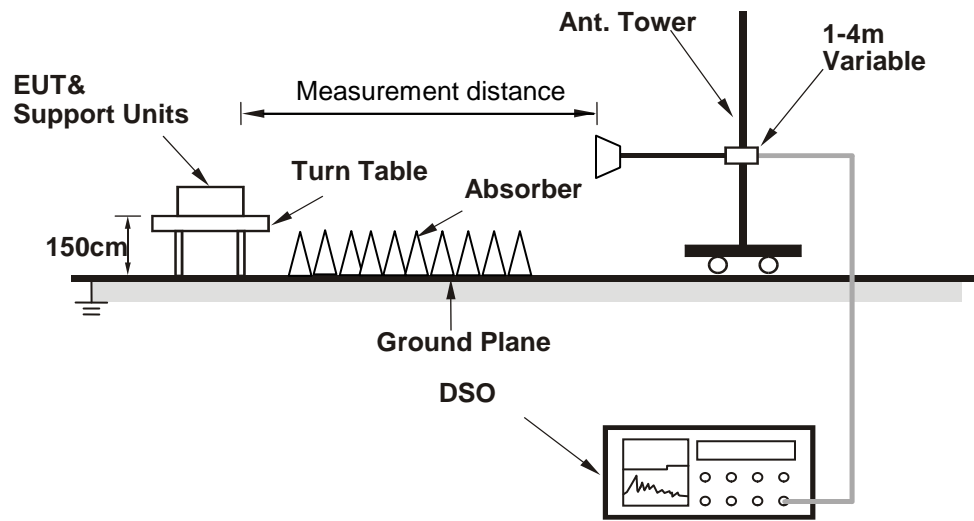

#### 4.4.3 Test Instruments

Refer to section 4.1.2 to get information of above instrument.

#### 4.4.4 Test Procedures

- a. Place the EUT in a continuous transmission mode.
- b. For radiated emission measurements, attach a test receive antenna for the fundamental frequency band to the RF input of an RF detector or a downconverter with an RF detector at the output.
- c. Connect the video output of the detector to the 50 ohm input of the DSO.
- d. Place the test receive antenna in the main beam of the EUT at a distance which will provide a signal within the operating range of the RF detector.
- e. Set the sampling rate of the DSO to the required value. Adjust the memory depth, the triggering and the sweep speed to obtain a display which is representative of the signal considering the type of modulation.
- f. For radiated emission measurements, calculate the distance to the far field boundary of the fundamental emission using following equation

$$d_{\text{farfield}} = \frac{2D^2}{\lambda}$$

where:

**D** = largest dimension of the transmit antenna

**$\lambda$**  = wavelength

Frequency (GHz )	L (m)	Lambda (m)	R (Far Field) (m)
60.48	0.025	0.0050	0.25

- g. Perform radiated emission measurements to keep maximize the received signal from the EUT in the far field.
- h. Record the average and peak from the DSO and the measurement distance.
- i. Disconnect the EUT from the RF input port of the instrumentation system.
- j. Connect a mm-wave source to the RF input port of the instrumentation system via a waveguide variable attenuator. The mm-wave source is unmodulated.
- k. Using substitution measurement.
- l. Measure and note the power.
- m. For conducted power measurements, calculate the conducted power using following equation

$$P_{\text{cond}} = \text{EIRP} - G_{\text{dBi}}$$

#### 4.4.5 Deviation from Test Standard

No deviation.

#### 4.4.6 EUT Operating Conditions

Same as Item 4.3.6.

#### 4.4.7 Test Results (LRP Mode)

##### Channel Plan A

Channel	Frequency (GHz)	EIRP (dBm)	Max. Antenna Gain (dBi)	S.G Output Value (dBm)	Conducted Output Power (dBm)	Conducted Output Power (mW)	EIRP Limit (dBm)	Conducted Output Power limit (mW)	Pass /Fail
1	60.16	10.04	9	-10.96	1.04	1.27	43	451.9	Pass
2	60.48	10.48	9	-10.52	1.48	1.41	43	451.1	Pass
3	60.80	9.55	9	-11.45	0.55	1.14	43	452.05	Pass

Note: The 6dB bandwidth is less than 100MHz, therefore conducted power limit = 500mW x (6dB bandwidth /100).

##### Channel Plan B

Channel	Frequency (GHz)	EIRP (dBm)	Max. Antenna Gain (dBi)	S.G Output Value (dBm)	Conducted Output Power (dBm)	Conducted Output Power (mW)	EIRP Limit (dBm)	Conducted Output Power limit (mW)	Pass /Fail
1	62.32	8.55	9	-12.45	-0.45	0.90	43	87.86	Pass
2	62.64	8.83	9	-12.17	-0.17	0.96	43	90.08	Pass
3	62.96	7.92	9	-13.08	-1.08	0.78	43	87.68	Pass

Note: The 6dB bandwidth is less than 100MHz, therefore conducted power limit = 500mW x (6dB bandwidth /100).

#### 4.4.8 Test Results (HRP Mode)

Channel	Frequency (GHz)	EIRP (dBm)	Max. Antenna Gain (dBi)	S.G Output Value (dBm)	Conducted Output Power (dBm)	Conducted Output Power (mW)	EIRP Limit (dBm)	Conducted Output Power limit (mW)	Pass /Fail
1	60.48	12.11	9	-8.89	3.11	2.05	43	500	Pass
2	62.64	11.43	9	-9.57	2.43	1.75	43	500	Pass



## 4.5 Frequency Stability Measurement

### 4.5.1 Limits of Frequency Stability Measurement

15.255(f) Fundamental emissions must be contained within the frequency bands specified in this section during all conditions of operation. Equipment is presumed to operate over the temperature range -20 to +50 degrees Celsius with an input voltage variation of 85% to 115% of rated input voltage, unless justification is presented to demonstrate otherwise.

### 4.5.2 Test Setup

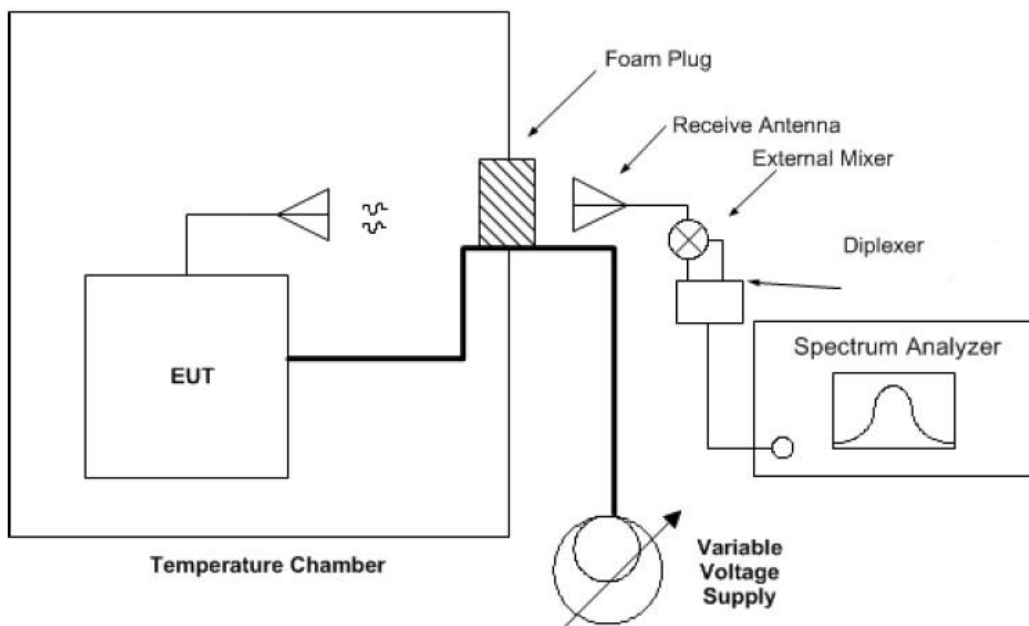

### 4.5.3 Test Instruments

Refer to section 4.1.2 to get information of above instrument.

### 4.5.4 Test Procedure

- Arrange EUT and test equipment as above setup configuration.
- With the EUT at ambient temperature and voltage source set to the EUT nominal operating voltage (100%), record the spectrum mask of the EUT emission on the spectrum analyzer.
- Vary EUT power supply between 85% and 115% of nominal, and record the frequency excursion of the EUT emission mask.
- Set the power supply to 100% nominal setting, and raise EUT operating temperature to 50 °C. Record the frequency excursion of the EUT emission mask.
- Repeat step d) at each 10 °C increment down to -20 °C

### 4.5.5 Deviation from Test Standard

No deviation.

### 4.5.6 EUT Operating Condition

Same as Item 4.3.6

## 4.5.7 Test Results

Frequency Stability Versus Temp.									
Operating Frequency: 60480 MHz									
TEMP. (°C)	Power Supply (Vdc)	0 Minute		2 Minutes		5 Minutes		10 Minutes	
		Measured Frequency (MHz)	Pass/Fail	Measured Frequency (MHz)	Pass/Fail	Measured Frequency (MHz)	Pass/Fail	Measured Frequency (MHz)	Pass/Fail
50	5	60480.1998	PASS	60480.1855	PASS	60480.2115	PASS	60480.2254	PASS
40	5	60479.9006	PASS	60479.9306	PASS	60479.9417	PASS	60479.9042	PASS
30	5	60480.0467	PASS	60480.0745	PASS	60480.0606	PASS	60480.0866	PASS
20	5	60480.1441	PASS	60480.1429	PASS	60480.1359	PASS	60480.0944	PASS
10	5	60480.2632	PASS	60480.2719	PASS	60480.2624	PASS	60480.283	PASS
0	5	60480.1462	PASS	60480.0903	PASS	60480.141	PASS	60480.0942	PASS
-10	5	60479.9087	PASS	60479.9214	PASS	60479.9174	PASS	60479.9592	PASS
-20	5	60480.181	PASS	60480.1351	PASS	60480.1816	PASS	60480.1603	PASS
-30	5	60480.1998	PASS	60480.1855	PASS	60480.2115	PASS	60480.2254	PASS

Frequency Stability Versus Voltage									
Operating Frequency: 60480 MHz									
TEMP. (°C)	Power Supply (Vdc)	0 Minute		2 Minutes		5 Minutes		10 Minutes	
		Measured Frequency (MHz)	Pass/Fail	Measured Frequency (MHz)	Pass/Fail	Measured Frequency (MHz)	Pass/Fail	Measured Frequency (MHz)	Pass/Fail
20	5.75	60480.1418	PASS	60480.1407	PASS	60480.1412	PASS	60480.0936	PASS
	5	60480.1441	PASS	60480.1429	PASS	60480.1359	PASS	60480.0944	PASS
	4.25	60480.1384	PASS	60480.1363	PASS	60480.1316	PASS	60480.0971	PASS

## 5 Pictures of Test Arrangements

Please refer to the attached file (Test Setup Photo).

## Appendix – Information on the Testing Laboratories

We, Bureau Veritas Consumer Products Services (H.K.) Ltd., Taoyuan Branch, were founded in 1988 to provide our best service in EMC, Radio, Telecom and Safety consultation. Our laboratories are FCC recognized accredited test firms and accredited according to ISO/IEC 17025.

If you have any comments, please feel free to contact us at the following:

**Linkou EMC/RF Lab**

Tel: 886-2-26052180

Fax: 886-2-26051924

**Hsin Chu EMC/RF/Telecom Lab**

Tel: 886-3-6668565

Fax: 886-3-6668323

**Hwa Ya EMC/RF/Safety Lab**

Tel: 886-3-3183232

Fax: 886-3-3270892

**Email:** [service.adt@tw.bureauveritas.com](mailto:service.adt@tw.bureauveritas.com)

**Web Site:** [www.bureauveritas-adt.com](http://www.bureauveritas-adt.com)

The address and road map of all our labs can be found in our web site also.

--- END ---