



FCC Test Report

FCC ID : 2ALHR005
Equipment : 2ALHR005
Brand Name : Fieldpiece
Model Name : 2ALHR005
Applicant : Fieldpiece Instruments, Inc.
1636 West Collins Ave
Orange CA 92867
Manufacturer : CHY FIREMATE CO., LTD.
No.3, Shengli 1st St., Rende Dist., Tainan City 717,
Taiwan (R.O.C.)
Standard : 47 CFR FCC Part 15.247

The product was received on May 28, 2018, and testing was started from Jun. 19, 2018 and completed on Nov. 08, 2018. We, SPORTON INTERNATIONAL INC. EMC & Wireless Communications Laboratory, would like to declare that the tested sample has been evaluated in accordance with the procedures given in ANSI C63.10-2013 and shown compliance with the applicable technical standards.

The report must not be used by the client to claim product certification, approval, or endorsement by TAF or any agency of government.

The test results in this report apply exclusively to the tested model / sample. Without written approval of SPORTON INTERNATIONAL INC. EMC & Wireless Communications Laboratory, the test report shall not be reproduced except in full.

Approved by: Allen Lin

SPORTON INTERNATIONAL INC. EMC & Wireless Communications Laboratory

No. 52, Huaya 1st Rd., Guishan Dist., Taoyuan City, Taiwan (R.O.C.)



Table of Contents

HISTORY OF THIS TEST REPORT3

SUMMARY OF TEST RESULT4

1 GENERAL DESCRIPTION5

1.1 Information.....5

1.2 Testing Applied Standards6

1.3 Testing Location Information6

1.4 Measurement Uncertainty6

2 TEST CONFIGURATION OF EUT.....7

2.1 Test Condition7

2.2 Test Channel Mode7

2.3 The Worst Case Measurement Configuration.....8

2.4 Support Equipment.....9

2.5 Test Setup Diagram10

3 TRANSMITTER TEST RESULT12

3.1 AC Power-line Conducted Emissions12

3.2 DTS Bandwidth14

3.3 Maximum Conducted Output Power15

3.4 Power Spectral Density17

3.5 Emissions in Non-restricted Frequency Bands18

3.6 Emissions in Restricted Frequency Bands.....19

4 TEST EQUIPMENT AND CALIBRATION DATA23

APPENDIX A. TEST RESULTS OF AC POWER-LINE CONDUCTED EMISSIONS

APPENDIX B. TEST RESULTS OF DTS BANDWIDTH

APPENDIX C. TEST RESULTS OF MAXIMUM CONDUCTED OUTPUT POWER

APPENDIX D. TEST RESULTS OF POWER SPECTRAL DENSITY

APPENDIX E. TEST RESULTS OF EMISSIONS IN NON-RESTRICTED FREQUENCY BANDS

APPENDIX F. TEST RESULTS OF EMISSIONS IN RESTRICTED FREQUENCY BANDS

APPENDIX G. TEST PHOTOS

PHOTOGRAPHS OF EUT V01



History of this test report

Report No.	Version	Description	Issued Date
FR852404AL	01	Initial issue of report	Oct. 22, 2018
FR852404AL	02	AC power-line conducted emissions was evaluated	Nov. 08, 2018



Summary of Test Result

Report Clause	Ref. Std. Clause	Test Items	Result (PASS/FAIL)	Remark
1.1.2	15.203	Antenna Requirement	PASS	FCC 15.203
3.1	15.207	AC Power-line Conducted Emissions	PASS	FCC 15.207
3.2	15.247(a)	DTS Bandwidth	PASS	≥500kHz
3.3	15.247(b)	Maximum Conducted Output Power	PASS	Power [dBm]:30
3.4	15.247(e)	Power Spectral Density	PASS	PSD [dBm/3kHz]:8
3.5	15.247(d)	Emissions in Non-restricted Frequency Bands	PASS	Non-Restricted Bands: >30 dBc
3.6	15.247(d)	Emissions in Restricted Frequency Bands	PASS	Restricted Bands: FCC 15.209

Reviewed by: Ben Tseng

Report Producer: Jenny Yang

1 General Description

1.1 Information

1.1.1 RF General Information

Frequency Range (MHz)	Bluetooth Mode	Ch. Frequency (MHz)	Channel Number
2400-2483.5	LE	2402-2480	0-39 [40]

Band	Mode	BWch (MHz)	Nant
2.4-2.4835GHz	BT-LE(1Mbps)	1.0	1TX

Note:

- ♦ Bluetooth LE uses a GFSK (1Mbps) modulation for DSSS.
- ♦ BWch is the nominal channel bandwidth.

1.1.2 Antenna Information

Ant.	Port	Brand	Model Name	Antenna Type	Connector	Gain (dBi)
1	1	-	-	PCB antenna	Murata	2.43

For BT function:

For IEEE 802.15.1 Bluetooth mode (1TX/1RX)

Only Ant. 1 (port 1) can be used as transmitting/receiving antenna.

1.1.3 EUT Information

Operational Condition	
EUT Power Type	From Battery & DC power supply
EUT Function	<input type="checkbox"/> Point-to-multipoint <input checked="" type="checkbox"/> Point-to-point
Type of EUT	
<input checked="" type="checkbox"/>	Stand-alone
<input type="checkbox"/>	Combined (EUT where the radio part is fully integrated within another device)
	Combined Equipment - Brand Name / Model No.: ...
<input type="checkbox"/>	Plug-in radio (EUT intended for a variety of host systems)
	Host System - Brand Name / Model No.: ...
<input type="checkbox"/>	Other:

1.1.4 Mode Test Duty Cycle

Mode	DC	DCF(dB)	T(s)	VBW(Hz) ≥ 1/T
BT-LE(1Mbps)	1	0	n/a (DC>=0.98)	n/a (DC>=0.98)

1.2 Testing Applied Standards

According to the specifications of the manufacturer, the EUT must comply with the requirements of the following standards:

- ◆ 47 CFR FCC Part 15
- ◆ ANSI C63.10-2013
- ◆ KDB 558074 D01 v05

1.3 Testing Location Information

Testing Location		
<input checked="" type="checkbox"/>	HWA YA	ADD : No. 52, Huaya 1st Rd., Guishan Dist., Taoyuan City, Taiwan (R.O.C.) TEL : 886-3-327-3456 FAX : 886-3-327-0973
Test site Designation No. TW1190 with FCC.		
<input type="checkbox"/>	JHUBEI	ADD : No.8, Ln. 724, Bo'ai St., Zhubei City, Hsinchu County, Taiwan (R.O.C.) TEL : 886-3-656-9065 FAX : 886-3-656-9085
Test site Designation No. TW0006 with FCC.		

Test Condition	Test Site No.	Test Engineer	Test Environment	Test Date
RF Conducted	TH06-HY	Tim	23.2°C / 65%	25/Jun/2018
Radiated	03CH09-HY	Jerry	25.5°C / 55%	19/Jun/2018
AC Conduction	CO04-HY	Andy	21.8°C / 60%	08/Nov/2018

1.4 Measurement Uncertainty

ISO/IEC 17025 requires that an estimate of the measurement uncertainties associated with the emissions test results be included in the report. The measurement uncertainties given below are based on a 95% confidence level (based on a coverage factor (k=2))

Test Items	Uncertainty	Remark
Conducted Emission (150kHz ~ 30MHz)	3.6 dB	Confidence levels of 95%
Radiated Emission (9kHz ~ 30MHz)	3.0 dB	Confidence levels of 95%
Radiated Emission (30MHz ~ 1,000MHz)	4.3 dB	Confidence levels of 95%
Radiated Emission (1GHz ~ 18GHz)	3.9 dB	Confidence levels of 95%
Radiated Emission (18GHz ~ 40GHz)	3.5 dB	Confidence levels of 95%
Conducted Emission	1.3 dB	Confidence levels of 95%
Temperature	0.7 °C	Confidence levels of 95%
Humidity	4 %	Confidence levels of 95%



2 Test Configuration of EUT

2.1 Test Condition

RF Conducted	Abbreviation	Remark
TnomVnom	Tnom	20°C
-	Vnom	9V

2.2 Test Channel Mode



Test Software Version	Ver. 1.7.5
-----------------------	------------

Mode	Power Setting
BT-LE(1Mbps)	-
2402MHz	-6
2440MHz	-6
2480MHz	-6

2.3 The Worst Case Measurement Configuration

The Worst Case Mode for Following Conformance Tests	
Tests Item	AC power-line conducted emissions
Condition	AC power-line conducted measurement for line and neutral
Operating Mode	CTX
1	DC Power Supply mode

The Worst Case Mode for Following Conformance Tests	
Tests Item	DTS Bandwidth Maximum Conducted Output Power Power Spectral Density Emissions in Non-restricted Frequency Bands
Test Condition	Conducted measurement at transmit chains

The Worst Case Mode for Following Conformance Tests			
Tests Item	Emissions in Restricted Frequency Bands		
Test Condition	Radiated measurement If EUT consist of multiple antenna assembly (multiple antenna are used in EUT regardless of spatial multiplexing MIMO configuration), the radiated test should be performed with highest antenna gain of each antenna type.		
Operating Mode < 1GHz	CTX		
1	Battery Mode		
Operating Mode > 1GHz	CTX		
Orthogonal Planes of EUT	X Plane	Y Plane	Z Plane
			
Worst Planes of EUT		V	

2.4 Support Equipment

Support Equipment – RF Conducted				
No.	Equipment	Brand Name	Model Name	FCC ID
1	Notebook	HIPRO	HP-A0904A3	-
2	Adapter for NB	ACER	ZQW	-
3	Fixture	-	-	-
4	DC Power supply	GW	GPS-3030DD	-

Note: Support equipment No.1, 2, 3 were provided by customer.

Support Equipment – Radiated Emission				
No.	Equipment	Brand Name	Model Name	FCC ID
1	Fixture	-	-	-
2	Battery	-	-	-

Note: Support equipment No.1 was provided by customer.

Support Equipment – AC Conduction				
No.	Equipment	Brand Name	Model Name	FCC ID
1	DC power supply	GW	GPS-3030DD	-

2.5 Test Setup Diagram

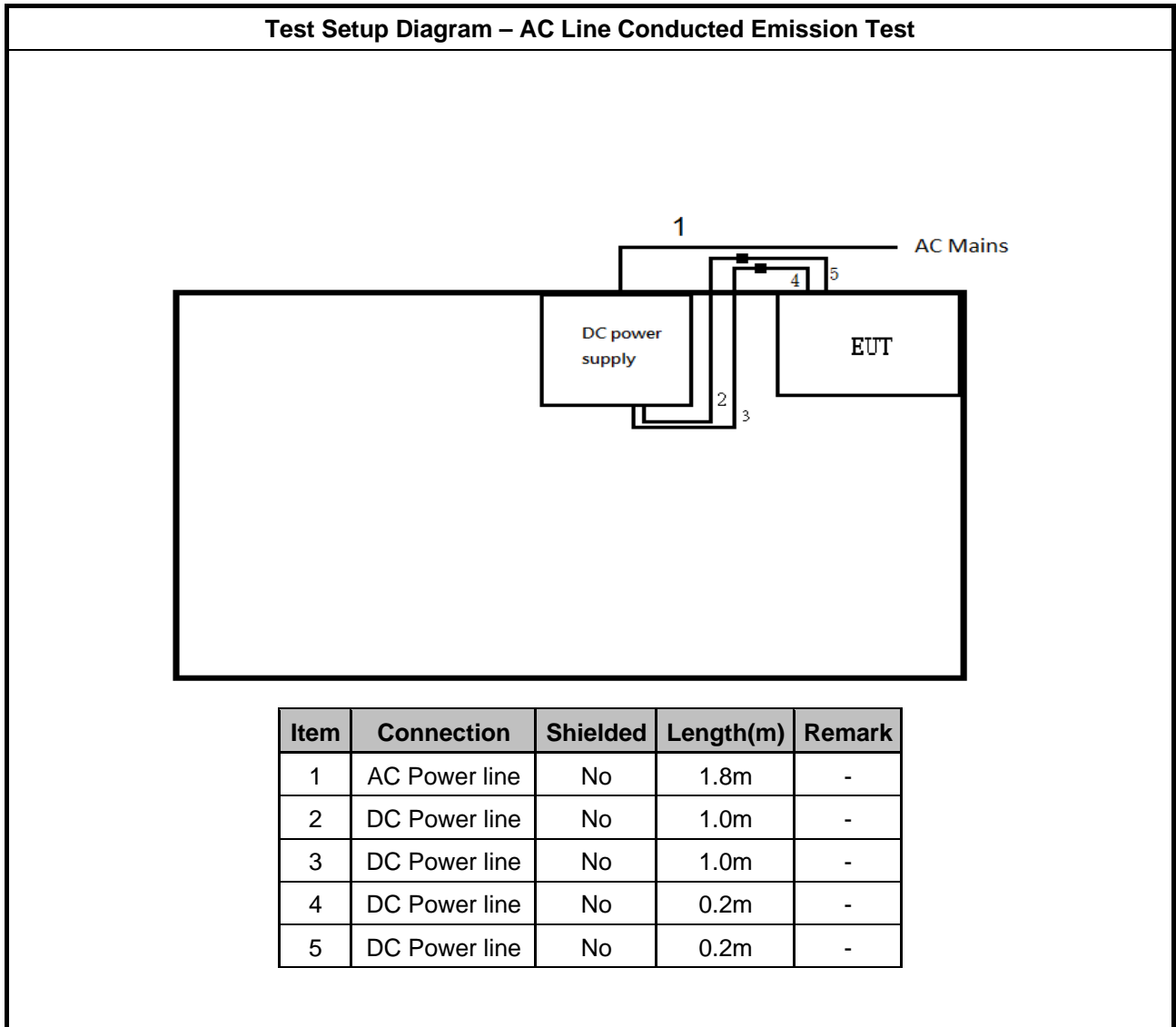

Test Setup Diagram - Radiated Test

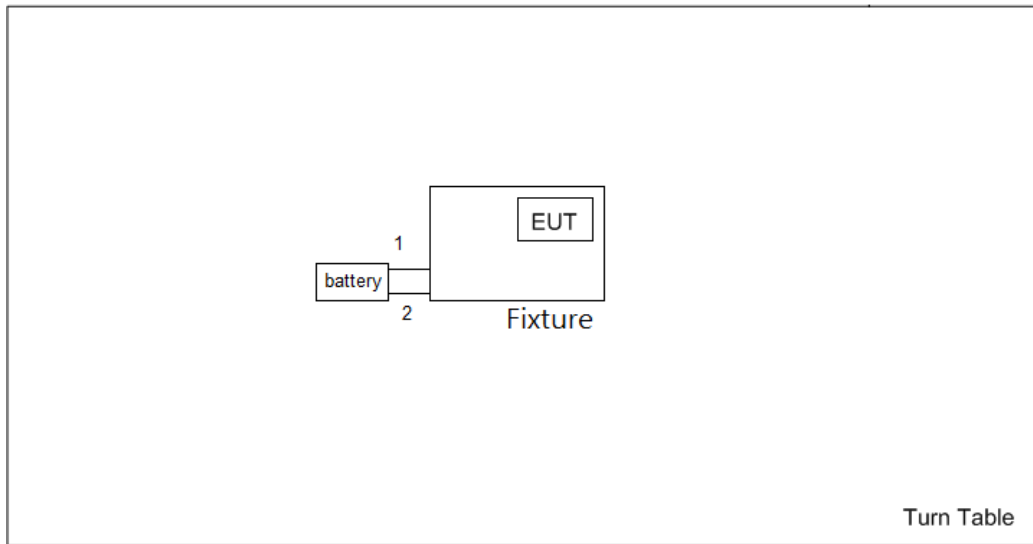

Item	Connection	Shielded	Length(m)	Remark
1	DC power line	No	0.15m	
2	DC power line	No	0.15m	-

3 Transmitter Test Result

3.1 AC Power-line Conducted Emissions

3.1.1 AC Power-line Conducted Emissions Limit

AC Power-line Conducted Emissions Limit		
Frequency Emission (MHz)	Quasi-Peak	Average
0.15-0.5	66 - 56 *	56 - 46 *
0.5-5	56	46
5-30	60	50

Note 1: * Decreases with the logarithm of the frequency.

3.1.2 Measuring Instruments

Refer a test equipment and calibration data table in this test report.

3.1.3 Test Procedures

Test Method
<ul style="list-style-type: none"> Refer as ANSI C63.10-2013, clause 6.2 foray power-line conducted emissions.

3.1.4 Test Setup

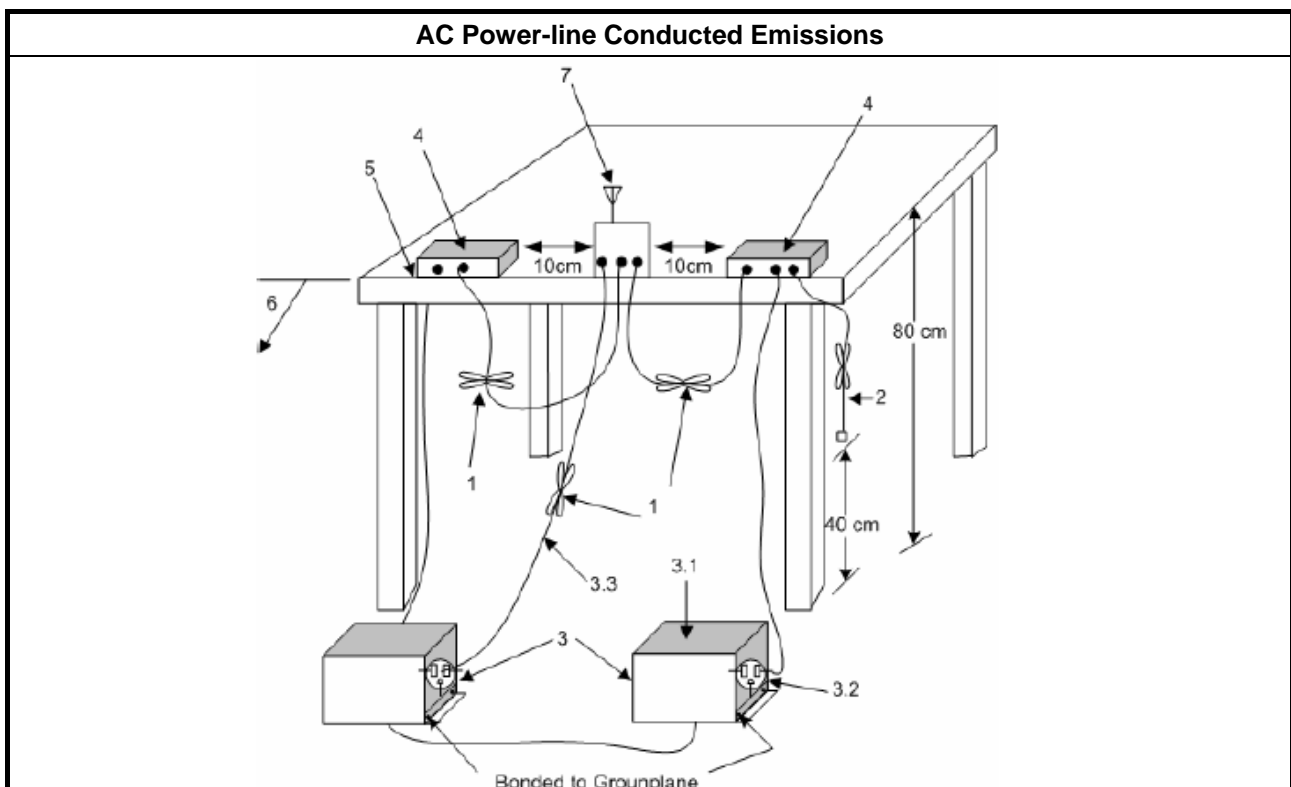



3.1.5 Test Result of AC Power-line Conducted Emissions

Refer as Appendix A

3.2 DTS Bandwidth

3.2.1 6dB Bandwidth Limit

6dB Bandwidth Limit
Systems using digital modulation techniques:
<ul style="list-style-type: none"> ▪ 6 dB bandwidth \geq 500 kHz.

3.2.2 Measuring Instruments

Refer a test equipment and calibration data table in this test report.

3.2.3 Test Procedures

Test Method
<ul style="list-style-type: none"> ▪ For the emission bandwidth shall be measured using one of the options below:
<input checked="" type="checkbox"/> Refer as KDB 558074, clause 8.2 (11.9.2.2 of ANSI C63.10) DTS bandwidth measurement.
<input type="checkbox"/> Refer as RSS-Gen, clause 6.7 for for occupied bandwidth testing.
<input type="checkbox"/> Refer as ANSI C63.10, clause 6.9.3 for occupied bandwidth testing.

3.2.4 Test Setup

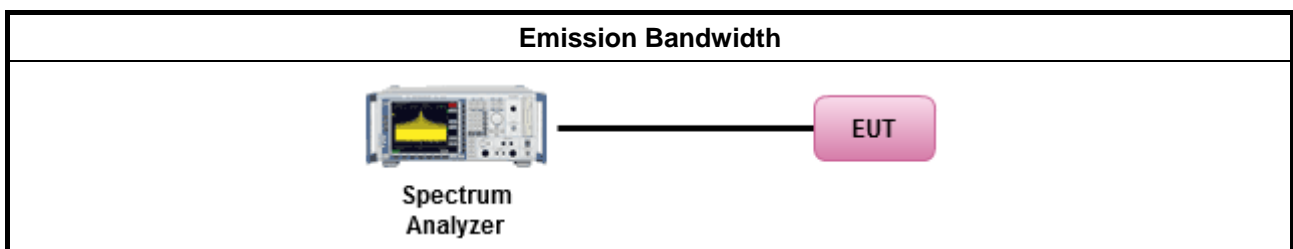

3.2.5 Test Result of Emission Bandwidth

Refer as Appendix B

3.3 Maximum Conducted Output Power

3.3.1 Maximum Conducted Output Power Limit

Maximum Conducted Output Power Limit	
	<ul style="list-style-type: none"> ▪ If $G_{TX} \leq 6$ dBi, then $P_{Out} \leq 30$ dBm (1 W)
	<ul style="list-style-type: none"> ▪ Point-to-multipoint systems (P2M): If $G_{TX} > 6$ dBi, then $P_{Out} = 30 - (G_{TX} - 6)$ dBm
	<ul style="list-style-type: none"> ▪ Point-to-point systems (P2P): If $G_{TX} > 6$ dBi, then $P_{Out} = 30 - (G_{TX} - 6)/3$ dBm
	<ul style="list-style-type: none"> ▪ Smart antenna system (SAS):
	<ul style="list-style-type: none"> - Single beam: If $G_{TX} > 6$ dBi, then $P_{Out} = 30 - (G_{TX} - 6)/3$ dBm
	<ul style="list-style-type: none"> - Overlap beam: If $G_{TX} > 6$ dBi, then $P_{Out} = 30 - (G_{TX} - 6)/3$ dBm
	<ul style="list-style-type: none"> - Aggregate power on all beams: If $G_{TX} > 6$ dBi, then $P_{Out} = 30 - (G_{TX} - 6)/3 + 8$ dB dBm
e.i.r.p. Power Limit:	
	<ul style="list-style-type: none"> ▪ 2400-2483.5 MHz Band
	<ul style="list-style-type: none"> ▪ Point-to-multipoint systems (P2M): $P_{eirp} \leq 36$ dBm (4 W)
	<ul style="list-style-type: none"> ▪ Point-to-point systems (P2P): $P_{eirp} \leq \text{MAX}(36, [P_{Out} + G_{TX}])$ dBm
	<ul style="list-style-type: none"> ▪ Smart antenna system (SAS)
	<ul style="list-style-type: none"> - Single beam: $P_{eirp} \leq \text{MAX}(36, P_{Out} + G_{TX})$ dBm
	<ul style="list-style-type: none"> - Overlap beam: $P_{eirp} \leq \text{MAX}(36, P_{Out} + G_{TX})$ dBm
	<ul style="list-style-type: none"> - Aggregate power on all beams: $P_{eirp} \leq \text{MAX}(36, [P_{Out} + G_{TX} + 8])$ dBm
<p>P_{Out} = maximum peak conducted output power or maximum conducted output power in dBm, G_{TX} = the maximum transmitting antenna directional gain in dBi.</p>	

3.3.2 Measuring Instruments

Refer a test equipment and calibration data table in this test report.

3.3.3 Test Procedures

Test Method	
<ul style="list-style-type: none"> ▪ Maximum Peak Conducted Output Power 	
<input type="checkbox"/>	Refer as KDB 558074, clause 8.3.1.1 (11.9.1.1 of ANSI C63.10) RBW ≥ EBW method.
<input type="checkbox"/>	Refer as KDB 558074, clause 8.3.1.2 (11.9.1.2 of ANSI C63.10) integrated band power method.
<input type="checkbox"/>	Refer as KDB 558074, clause 8.3.1.3 (11.9.1.3 of ANSI C63.10) peak power meter.
<ul style="list-style-type: none"> ▪ Maximum Average Conducted Output Power 	
<input type="checkbox"/>	Refer as KDB 558074, clause 8.3.2.2 (11.9.2.2 of ANSI C63.10) using a spectrum analyzer.
<input checked="" type="checkbox"/>	Refer as KDB 558074, clause 8.3.2.3 (11.9.2.3 of ANSI C63.10) using a power meter.
<ul style="list-style-type: none"> ▪ For conducted measurement. 	
<ul style="list-style-type: none"> ▪ If the EUT supports multiple transmit chains using options given below: Refer as KDB 662911, In-band power measurements. Using the measure-and-sum approach, measured all transmit ports individually. Sum the power (in linear power units e.g., mW) of all ports for each individual sample and save them. 	
<ul style="list-style-type: none"> ▪ If multiple transmit chains, EIRP calculation could be following as methods: $P_{total} = P_1 + P_2 + \dots + P_n$ (calculated in linear unit [mW] and transfer to log unit [dBm]) $EIRP_{total} = P_{total} + DG$ 	

3.3.4 Test Setup

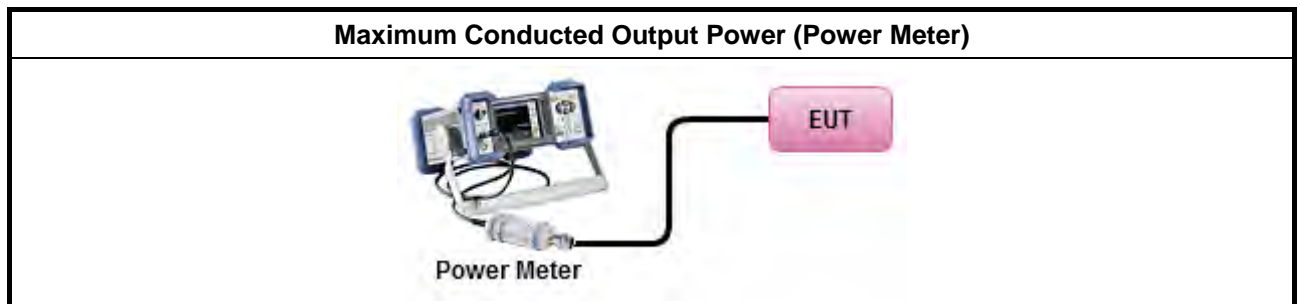

3.3.5 Test Result of Maximum Conducted Output Power

Refer as Appendix C

3.4 Power Spectral Density

3.4.1 Power Spectral Density Limit

Power Spectral Density Limit
<ul style="list-style-type: none"> Power Spectral Density (PSD) ≤ 8 dBm/3kHz

3.4.2 Measuring Instruments

Refer a test equipment and calibration data table in this test report.

3.4.3 Test Procedures

Test Method
<ul style="list-style-type: none"> Peak power spectral density procedures that the same method as used to determine the conducted output power. If maximum peak conducted output power was measured to demonstrate compliance to the output power limit, then the peak PSD procedure below (Method PKPSD) shall be used. If maximum conducted output power was measured to demonstrate compliance to the output power limit, then one of the average PSD procedures shall be used, as applicable based on the following criteria (the peak PSD procedure is also an acceptable option).
<input checked="" type="checkbox"/> Refer as KDB 558074, clause 8.4 (11.10 of ANSI C63.10) Method PKPSD.
<ul style="list-style-type: none"> For conducted measurement.
<ul style="list-style-type: none"> If The EUT supports multiple transmit chains using options given below:
<ul style="list-style-type: none"> Measure and sum the spectra across the outputs. Refer as KDB 662911, In-band power spectral density (PSD). Sample all transmit ports simultaneously using a spectrum analyzer for each transmit port. Where the trace bin-by-bin of each transmit port summing can be performed. (i.e., in the first spectral bin of output 1 is summed with that in the first spectral bin of output 2 and that from the first spectral bin of output 3, and so on up to the NTX output to obtain the value for the first frequency bin of the summed spectrum.). Add up the amplitude (power) values for the different transmit chains and use this as the new data trace.

3.4.4 Test Setup

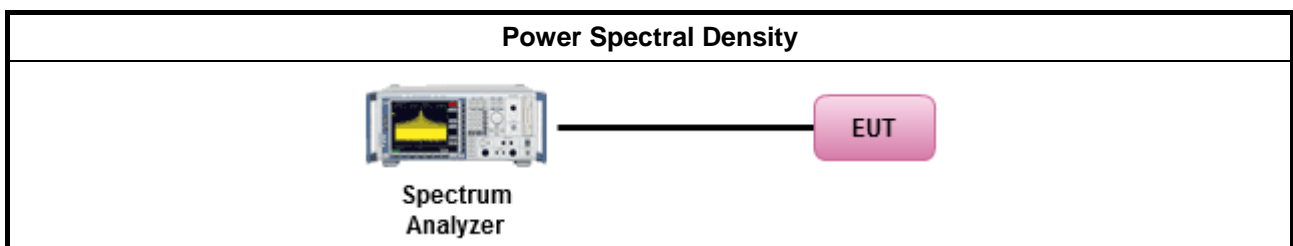

3.4.5 Test Result of Power Spectral Density

Refer as Appendix D

3.5 Emissions in Non-restricted Frequency Bands

3.5.1 Emissions in Non-restricted Frequency Bands Limit

Un-restricted Band Emissions Limit	
RF output power procedure	Limit (dB)
Peak output power procedure	20
Average output power procedure	30

Note 1: If the peak output power procedure is used to measure the fundamental emission power to demonstrate compliance to requirements, then the peak conducted output power measured within any 100 kHz outside the authorized frequency band shall be attenuated by at least 20 dB relative to the maximum measured in-band peak PSD level.

Note 2: If the average output power procedure is used to measure the fundamental emission power to demonstrate compliance to requirements, then the power in any 100 kHz outside of the authorized frequency band shall be attenuated by at least 30 dB relative to the maximum measured in-band average PSD level.

3.5.2 Measuring Instruments

Refer a test equipment and calibration data table in this test report.

3.5.3 Test Procedures

Test Method
<ul style="list-style-type: none"> Refer as KDB 558074, clause 8.5 (11.11 of ANSI C63.10) for non-restricted frequency bands.

3.5.4 Test Setup

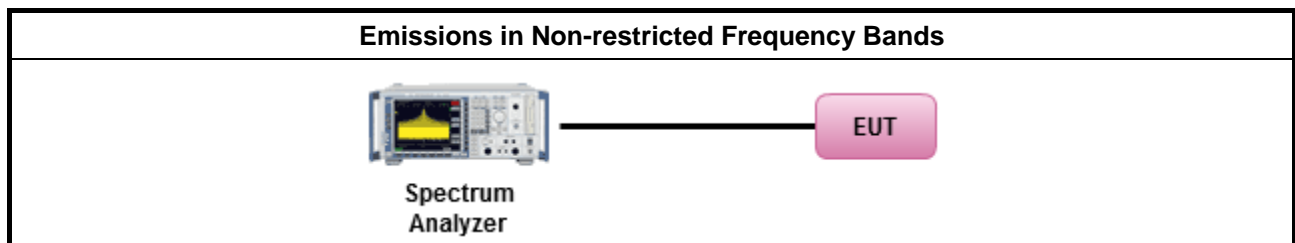

3.5.5 Test Result of Emissions in Non-restricted Frequency Bands

Refer as Appendix E

3.6 Emissions in Restricted Frequency Bands

3.6.1 Emissions in Restricted Frequency Bands Limit

Restricted Band Emissions Limit			
Frequency Range (MHz)	Field Strength (uV/m)	Field Strength (dBuV/m)	Measure Distance (m)
0.009~0.490	2400/F(kHz)	48.5 - 13.8	300
0.490~1.705	24000/F(kHz)	33.8 - 23	30
1.705~30.0	30	29	30
30~88	100	40	3
88~216	150	43.5	3
216~960	200	46	3
Above 960	500	54	3

Note 1: Test distance for frequencies at or above 30 MHz, measurements may be performed at a distance other than the limit distance provided they are not performed in the near field and the emissions to be measured can be detected by the measurement equipment. When performing measurements at a distance other than that specified, the results shall be extrapolated to the specified distance using an extrapolation factor of 20 dB/decade (inverse of linear distance for field-strength measurements, inverse of linear distance-squared for power-density measurements).

Note 2: Test distance for frequencies at below 30 MHz, measurements may be performed at a distance closer than the EUT limit distance; however, an attempt should be made to avoid making measurements in the near field. When performing measurements below 30 MHz at a closer distance than the limit distance, the results shall be extrapolated to the specified distance by either making measurements at a minimum of two or more distances on at least one radial to determine the proper extrapolation factor or by using the square of an inverse linear distance extrapolation factor (40 dB / decade). The test report shall specify the extrapolation method used to determine compliance of the EUT.

Note 3: Using the distance of 1m during the test for above 18 GHz, and the test value to correct for the distance factor at 3m.

3.6.2 Measuring Instruments

Refer a test equipment and calibration data table in this test report.



3.6.3 Test Procedures

Test Method	
	<ul style="list-style-type: none">▪ The average emission levels shall be measured in [duty cycle \geq 98 or duty factor].
	<ul style="list-style-type: none">▪ Refer as ANSI C63.10, clause 6.10.3 band-edge testing shall be performed at the lowest frequency channel and highest frequency channel within the allowed operating band.
	<ul style="list-style-type: none">▪ For the transmitter unwanted emissions shall be measured using following options below:
	<ul style="list-style-type: none"><ul style="list-style-type: none">▪ Refer as KDB 558074, clause 8.6 (11.12 of ANSI C63.10) for restricted frequency bands.
	<ul style="list-style-type: none">▪ For the transmitter band-edge emissions shall be measured using following options below:
	<ul style="list-style-type: none"><ul style="list-style-type: none">▪ Refer as KDB 558074 clause 8.7.1, When the performing peak or average radiated measurements, emissions within 2 MHz of the authorized band edge may be measured using the marker-delta method described below.
	<ul style="list-style-type: none"><ul style="list-style-type: none">▪ Refer as KDB 558074, clause 8.7.2 (6.10.6 of ANSI C63.10) for marker-delta method for band-edge measurements.
	<ul style="list-style-type: none"><ul style="list-style-type: none">▪ Refer as KDB 558074, clause 8.7.3 for narrower resolution bandwidth (100kHz) using the band power and summing the spectral levels (i.e., 1 MHz).

3.6.4 Test Setup

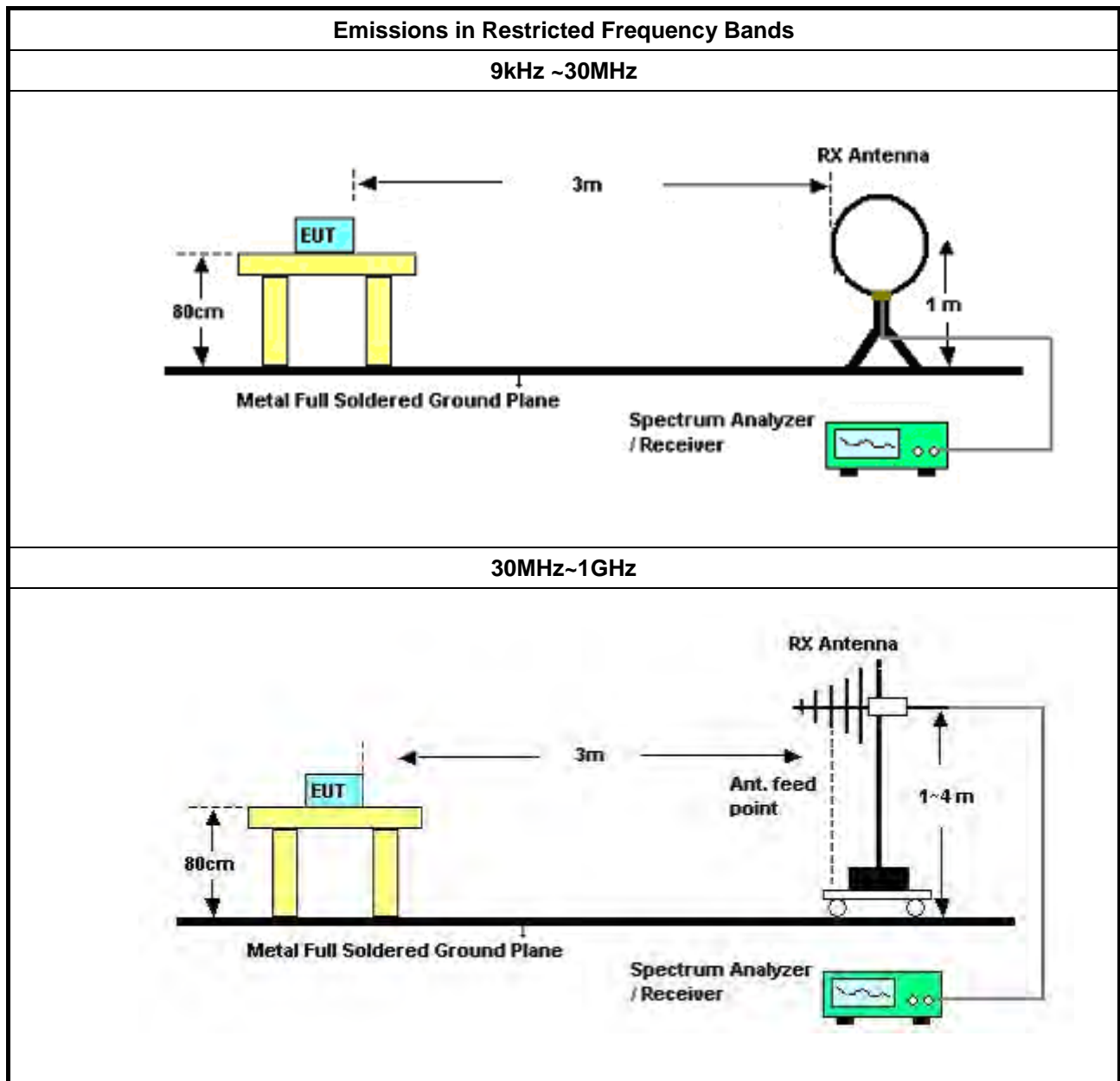

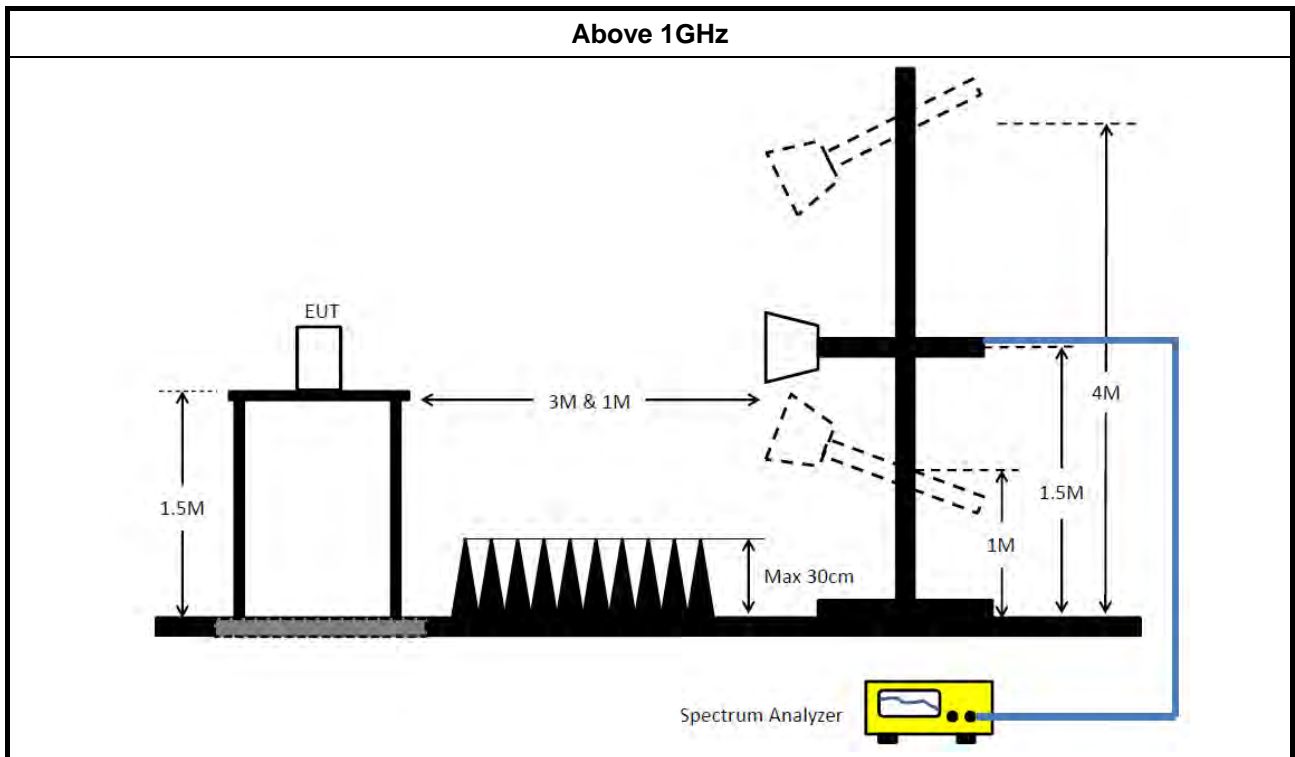

3.6.5 Test Result of Emissions in Restricted Frequency Bands (Below 30MHz)

The amplitude of spurious emissions which are attenuated by more than 20dB below the permissible value has no need to be reported.

3.6.6 Test Result of Emissions in Restricted Frequency Bands

Refer as Appendix F

4 Test Equipment and Calibration Data

Instrument for AC Conduction

Instrument	Manufacturer	Model No.	Serial No.	Spec.	Calibration Date	Calibration Due Date
EMC Receiver	R&S	ESR	102051	9KHz ~ 3.6GHz	03/May/2018	02/May/2019
LISN	R&S	ENV216	101295	9kHz ~ 30MHz	17/Nov/2017	16/Nov/2018
RF Cable-CON	MTJ	RG142	CB002-CO	9kHz ~ 200MHz	17/Sep/2018	16/Sep/2019
AC POWER	APC	AFC-11005G	F310050055	47Hz~63Hz 5~300V	NCR	NCR
Impuls Begrenzer Pulse Limiter	SCHWARZBECK	VTSD 9561-F	9561-F041	9 kHz ~ 30 MHz	12/Oct/2018	11/Oct/2019

NCR : Non-Calibration Require

Instrument for Conducted Test

Instrument	Manufacturer	Model No.	Serial No.	Spec.	Calibration Date	Calibration Due Date
Spectrum Analyzer	R&S	FSV 40	101013	9kHz~40GHz	29/Dec/2017	28/Dec/2018
Signal Generator	R&S	SMR40	100116	10MHz ~ 40GHz	27/Jul/2017	26/Jul/2018
Power Sensor	Anritsu	MA2411B	0917017	300MHz ~ 40GHz	05/Feb/2018	04/Feb/2019
Power Meter	Anritsu	ML2495A	0949003	300MHz ~ 40GHz	05/Feb/2018	04/Feb/2019
RF Cable-0.2m	HUBER+SUHNER	SUCOFLEX_104	MY10709/4	30MHz ~ 26.5GHz	25/Aug/2017	24/Aug/2018
RF Cable-0.2m	HUBER+SUHNER	SUCOFLEX_104	MY10712/4	30MHz ~ 26.5GHz	25/Aug/2017	24/Aug/2018
RF Cable-0.5m	HUBER+SUHNER	SUCOFLEX_104	MY10713/4	30MHz ~ 26.5GHz	25/Aug/2017	24/Aug/2018

**Instrument for Radiated Test**

Instrument	Manufacturer	Model No.	Serial No.	Spec.	Calibration Date	Calibration Due Date
3m Semi Anechoic Chamber	TDK	SAC-3M	03CH09-HY	30MHz ~ 1GHz	23/Apr/2018	22/Apr/2019
3m Semi Anechoic Chamber	TDK	SAC-3M	03CH09-HY	1GHz ~ 18GHz	14/Jun/2018	13/Jun/2019
Microwave Preamplifier	Agilent	8449B	3008A02096	1GHz ~ 26.5GHz	10/May/2018	09/May/2019
Amplifier	EMC	EMC9135	980232	9KHz~1GHz	27/Apr/2018	26/Apr/2019
EXA Signal Analyzer	KEYSIGHT	N9010A	MY54200885	10Hz ~ 44GHz	20/Jul/2017	19/Jul/2018
Bilog Antenna & 5dB Attenuator	TESEQ & MTJ	CBL6111D & MTJ6102-05	35418 / 3	30MHz~1GHz	09/Sep/2017	08/Sep/2018
Double Ridged Guide Horn Antenna	SCHWARZBECK	BBHA 9120 D	BBHA 9120 D 01543	1GHz ~ 18GHz	11/May/2018	10/May/2019
Broadband Horn Antenna	SCHWARZBECK	BBHA 9170	BBHA9170614	18GHz~40GHz	09/Feb/2018	08/Feb/2019
Loop Antenna	TESEQ	HLA 6120	31244	9k-30MHz	29/Mar/2018	28/Mar/2019
RF Cable-R03m	Jye Bao	RG142	CB031	9kHz ~ 1GHz	02/Feb/2018	01/Feb/2019
RF Cable-high	SUHNER	SUCOFLEX104	MY34918/4	1GHz ~ 40GHz	02/Feb/2018	01/Feb/2019



AC Power-line Conducted Emissions Result

Operating Mode	1	Power Phase	Neutral
Operating Function	DC Power Supply mode		

AC Conduction_Mode 1

08/11/2018

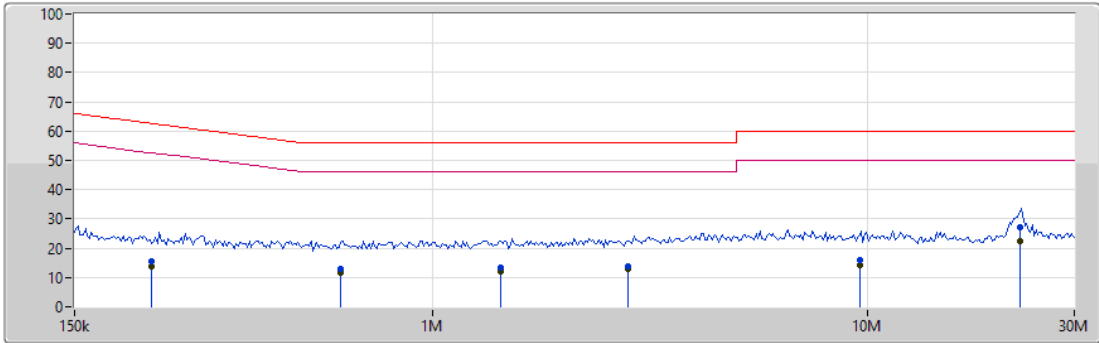

Type	Freq (Hz)	Level (dBuV)	Limit (dBuV)	Margin (dB)	Factor (dB)	Condition	Comment	Raw (dBuV)	LISN (dB)	CL (dB)	AT (dB)
QP	225.822k	15.51	62.60	-47.09	19.64	Neutral	-	-4.13	9.62	0.02	10.00
AV	225.822k	13.74	52.60	-38.86	19.64	Neutral	-	-5.90	9.62	0.02	10.00
QP	613.469k	12.99	56.00	-43.01	19.66	Neutral	-	-6.67	9.61	0.05	10.00
AV	613.469k	11.75	46.00	-34.25	19.66	Neutral	-	-7.91	9.61	0.05	10.00
QP	1.435M	13.19	56.00	-42.81	19.63	Neutral	-	-6.44	9.62	0.01	10.00
AV	1.435M	11.89	46.00	-34.11	19.63	Neutral	-	-7.74	9.62	0.01	10.00
QP	2.821M	13.97	56.00	-42.03	19.67	Neutral	-	-5.70	9.63	0.04	10.00
AV	2.821M	12.96	46.00	-33.04	19.67	Neutral	-	-6.71	9.63	0.04	10.00
QP	9.61M	16.08	60.00	-43.92	19.89	Neutral	-	-3.81	9.69	0.20	10.00
AV	9.61M	14.43	50.00	-35.57	19.89	Neutral	-	-5.46	9.69	0.20	10.00
QP	22.509M	27.15	60.00	-32.85	19.81	Neutral	-	7.34	9.71	0.10	10.00
AV	22.509M	22.34	50.00	-27.66	19.81	Neutral	"Worst"	2.53	9.71	0.10	10.00

Note 1: ">20dB" means emission levels that exceed the level of 20 dB below the applicable limit.
 Note 2: "N/F" means Nothing Found emissions (No emissions were detected.)



AC Power-line Conducted Emissions Result

Operating Mode	1	Power Phase	Line
Operating Function	DC Power Supply mode		

AC Conduction_Mode 1

08/11/2018

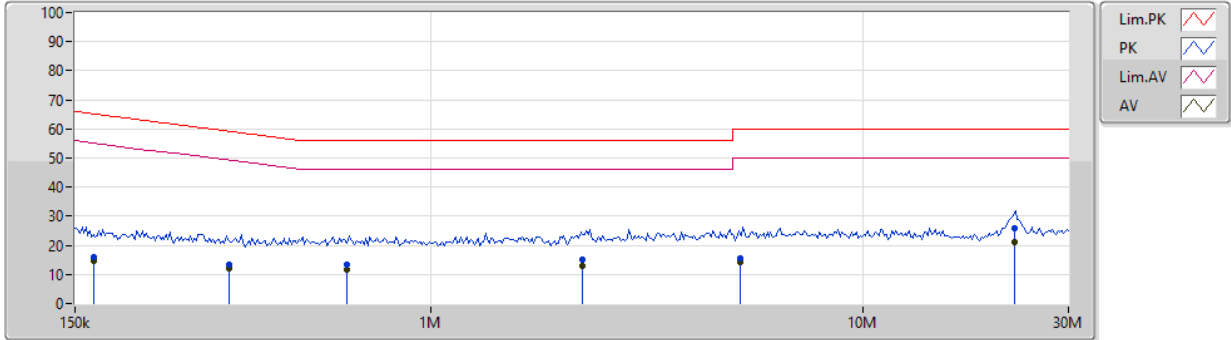

Type	Freq (Hz)	Level (dBuV)	Limit (dBuV)	Margin (dB)	Factor (dB)	Condition	Comment	Raw (dBuV)	LISN (dB)	CL (dB)	AT (dB)
QP	166.1k	15.76	65.16	-49.40	19.64	Line	-	-3.88	9.62	0.02	10.00
AV	166.1k	14.58	55.16	-40.58	19.64	Line	-	-5.06	9.62	0.02	10.00
QP	341.299k	13.41	59.17	-45.76	19.69	Line	-	-6.28	9.61	0.08	10.00
AV	341.299k	12.12	49.17	-37.05	19.69	Line	-	-7.57	9.61	0.08	10.00
QP	638.739k	13.23	56.00	-42.77	19.66	Line	-	-6.43	9.61	0.05	10.00
AV	638.739k	11.81	46.00	-34.19	19.66	Line	-	-7.85	9.61	0.05	10.00
QP	2.249M	15.01	56.00	-40.99	19.63	Line	-	-4.62	9.62	0.01	10.00
AV	2.249M	13.14	46.00	-32.86	19.63	Line	-	-6.49	9.62	0.01	10.00
QP	5.197M	15.36	60.00	-44.64	19.76	Line	-	-4.40	9.64	0.12	10.00
AV	5.197M	14.17	50.00	-35.83	19.76	Line	-	-5.59	9.64	0.12	10.00
QP	22.509M	25.84	60.00	-34.16	19.69	Line	-	6.15	9.59	0.10	10.00
AV	22.509M	21.19	50.00	-28.81	19.69	Line	"Worst"	1.50	9.59	0.10	10.00

Note 1: ">20dB" means emission levels that exceed the level of 20 dB below the applicable limit.
 Note 2: "N/F" means Nothing Found emissions (No emissions were detected.)



Summary

Mode	Max-N dB (Hz)	Max-OBW (Hz)	ITU-Code	Min-N dB (Hz)	Min-OBW (Hz)
2.4-2.4835GHz	-	-	-	-	-
BT-LE(1Mbps)	715k	1.066M	1M07F1D	683.75k	1.044M

Max-N dB = Maximum 6dB down bandwidth; **Max-OBW** = Maximum 99% occupied bandwidth;
Min-N dB = Minimum 6dB down bandwidth; **Min-OBW** = Minimum 99% occupied bandwidth;

Result

Mode	Result	Limit (Hz)	Port 1-N dB (Hz)	Port 1-OBW (Hz)
BT-LE(1Mbps)	-	-	-	-
2402MHz_TnomVnom	Pass	500k	683.75k	1.044M
2440MHz_TnomVnom	Pass	500k	715k	1.048M
2480MHz_TnomVnom	Pass	500k	715k	1.066M

Port X-N dB = Port X 6dB down bandwidth; **Port X-OBW** = Port X 99% occupied bandwidth;

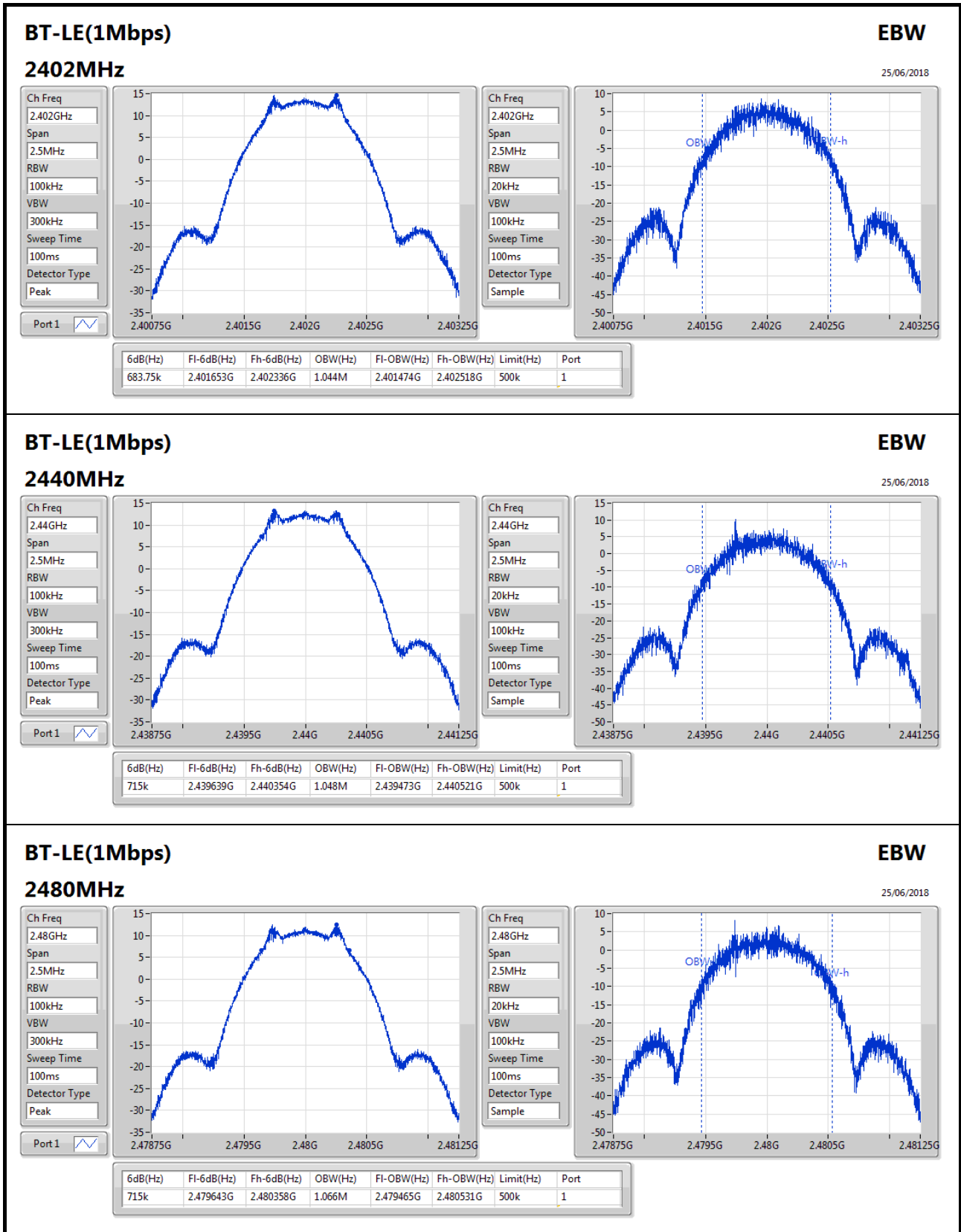
BT-LE(1Mbps)
EBW

25/06/2018

2480MHz

Ch Freq: 2.48GHz
Span: 2.5MHz
RBW: 100kHz
VBW: 300kHz
Sweep Time: 100ms
Detector Type: Peak

Port 1

Ch Freq: 2.48GHz
Span: 2.5MHz
RBW: 20kHz
VBW: 100kHz
Sweep Time: 100ms
Detector Type: Sample



Summary

Mode	Power (dBm)	Power (W)
2.4-2.4835GHz	-	-
BT-LE(1Mbps)	14.56	0.02858

Result

Mode	Result	Gain (dBi)	Power (dBm)	Power Limit (dBm)
BT-LE(1Mbps)	-	-	-	-
2402MHz_TnomVnom	Pass	2.43	14.56	30.00
2440MHz_TnomVnom	Pass	2.43	13.06	30.00
2480MHz_TnomVnom	Pass	2.43	12.52	30.00



Summary

Mode	PD (dBm/RBW)
2.4-2.4835GHz	-
BT-LE(1Mbps)	-0.18

RBW=3kHz.

Result

Mode	Result	Gain (dBi)	PD (dBm/RBW)	PD Limit (dBm/RBW)
BT-LE(1Mbps)	-	-	-	-
2402MHz_TnomVnom	Pass	2.43	-0.18	8.00
2440MHz_TnomVnom	Pass	2.43	-1.51	8.00
2480MHz_TnomVnom	Pass	2.43	-0.96	8.00

RBW=3kHz.

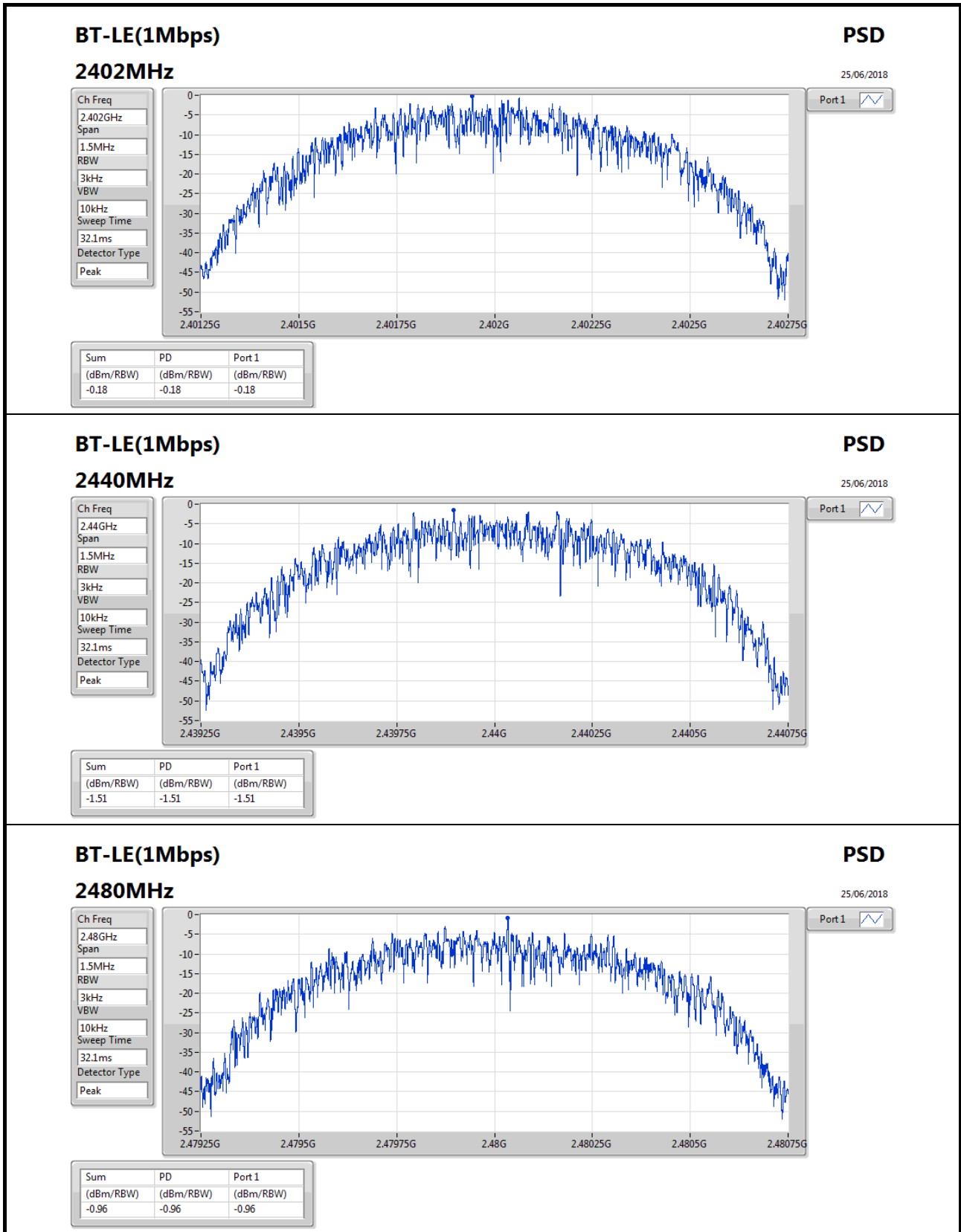



Summary

Mode	Result	Ref (Hz)	Ref (dBm)	Limit (dBm)	Freq (Hz)	Level (dBm)	Freq (Hz)	Level (dBm)	Freq (Hz)	Level (dBm)	Freq (Hz)	Level (dBm)	Port
2.4-2.4835GHz	-	-	-	-	-	-	-	-	-	-	-	-	-
BT-LE(1Mbps)	Pass	2.401837G	13.51	-16.49	2.102G	-49.59	2.399992G	-35.79	2.485012G	-57.27	14.412556G	-44.13	1

Result

Mode	Result	Ref (Hz)	Ref (dBm)	Limit (dBm)	Freq (Hz)	Level (dBm)	Freq (Hz)	Level (dBm)	Freq (Hz)	Level (dBm)	Freq (Hz)	Level (dBm)	Port
BT-LE(1Mbps)	-	-	-	-	-	-	-	-	-	-	-	-	-
2402MHz_TnomVnom	Pass	2.401837G	13.51	-16.49	2.102G	-49.59	2.399992G	-35.79	2.485012G	-57.27	14.412556G	-44.13	1
2440MHz_TnomVnom	Pass	2.401837G	13.51	-16.49	2.135152G	-54.57	2.399192G	-54.41	2.485416G	-56.96	2.592444G	-52.36	1
2480MHz_TnomVnom	Pass	2.401837G	13.51	-16.49	2.170672G	-56.78	2.399256G	-57.72	2.484608G	-48.45	2.502386G	-52.52	1

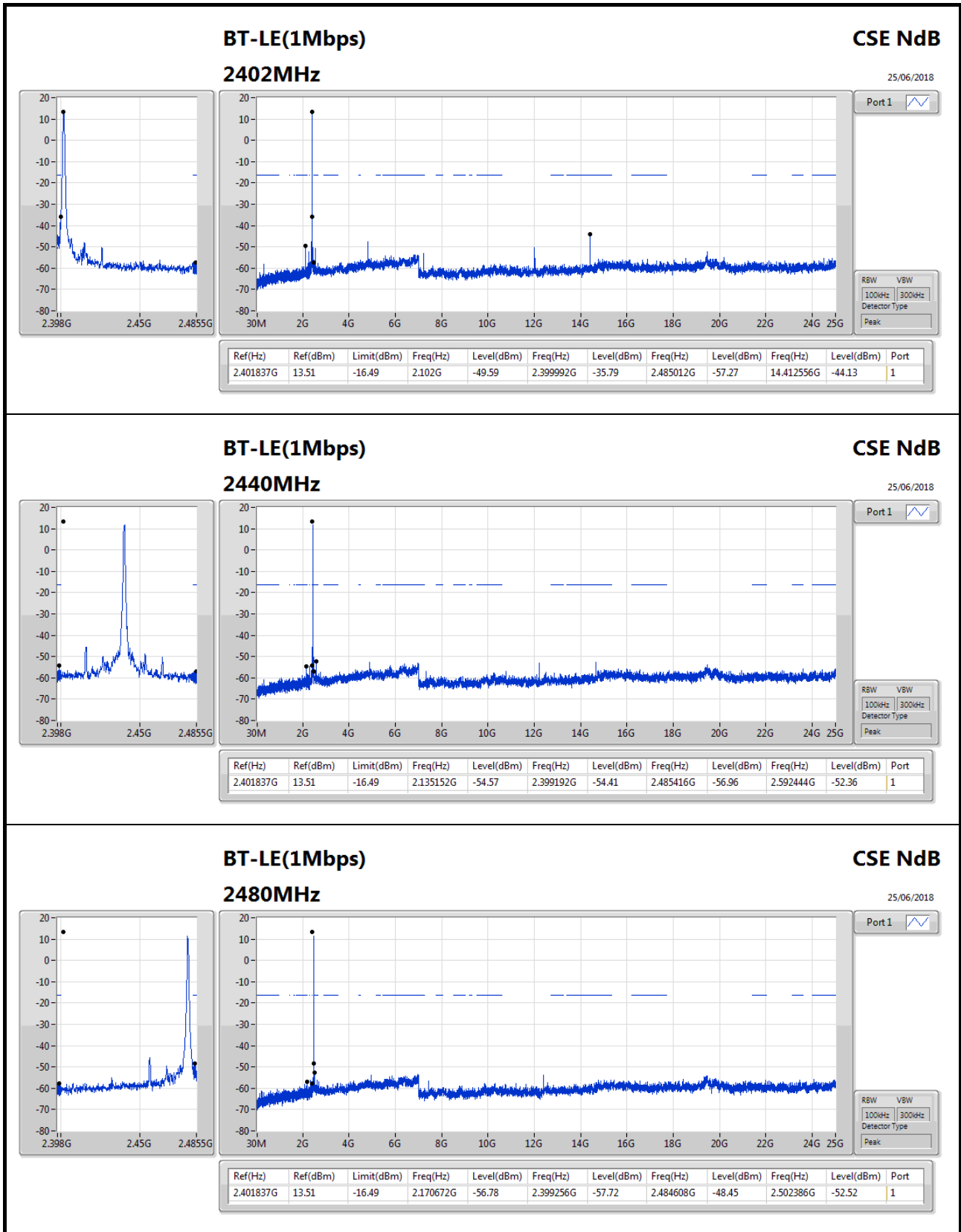

BT-LE(1Mbps)

2480MHz

CSE NdB

25/06/2018

Port1

Ref(Hz)	Ref(dBm)	Limit(dBm)	Freq(Hz)	Level(dBm)	Freq(Hz)	Level(dBm)	Freq(Hz)	Level(dBm)	Freq(Hz)	Level(dBm)	Port
2.401837G	13.51	-16.49	2.170672G	-56.78	2.399256G	-57.72	2.484608G	-48.45	2.502386G	-52.52	1



Summary

Mode	Result	Type	Freq (Hz)	Level (dBuV/m)	Limit (dBuV/m)	Margin (dB)	Factor (dB)	Dist (m)	Condition	Azimuth (°)	Height (m)	Comments
2.4-2.4835GHz	-	-	-	-	-	-	-	-	-	-	-	-
BT-LE(1Mbps)	Pass	PK	953.44M	36.09	46.00	-9.91	-4.71	3	Horizontal	0	1.00	-



Result

Mode	Result	Type	Freq (Hz)	Level (dBuV/m)	Limit (dBuV/m)	Margin (dB)	Factor (dB)	Dist (m)	Condition	Azimuth (°)	Height (m)	Comments
BT-LE(1Mbps)	-	-	-	-	-	-	-	-	-	-	-	-
2440MHz	Pass	PK	45.52M	20.91	40.00	-19.09	-21.27	3	Vertical	360	1.00	-
2440MHz	Pass	PK	92.08M	20.31	43.50	-23.19	-22.15	3	Vertical	360	1.00	-
2440MHz	Pass	PK	253.1M	24.30	46.00	-21.70	-16.68	3	Vertical	360	1.00	-
2440MHz	Pass	PK	493.66M	24.87	46.00	-21.13	-12.19	3	Vertical	360	1.00	-
2440MHz	Pass	PK	561.56M	24.00	46.00	-22.00	-10.34	3	Vertical	360	1.00	-
2440MHz	Pass	PK	953.44M	32.77	46.00	-13.23	-4.71	3	Vertical	360	1.00	-
2440MHz	Pass	PK	43.58M	24.28	40.00	-15.72	-20.25	3	Horizontal	0	1.00	-
2440MHz	Pass	PK	80.44M	19.94	40.00	-20.06	-23.85	3	Horizontal	0	1.00	-
2440MHz	Pass	PK	289.96M	30.14	46.00	-15.86	-16.89	3	Horizontal	0	1.00	-
2440MHz	Pass	PK	491.72M	25.99	46.00	-20.01	-12.21	3	Horizontal	0	1.00	-
2440MHz	Pass	PK	590.66M	25.57	46.00	-20.43	-10.95	3	Horizontal	0	1.00	-
2440MHz	Pass	PK	953.44M	36.09	46.00	-9.91	-4.71	3	Horizontal	0	1.00	-

BT-LE(1Mbps)

2440MHz_Battery

19/06/2018

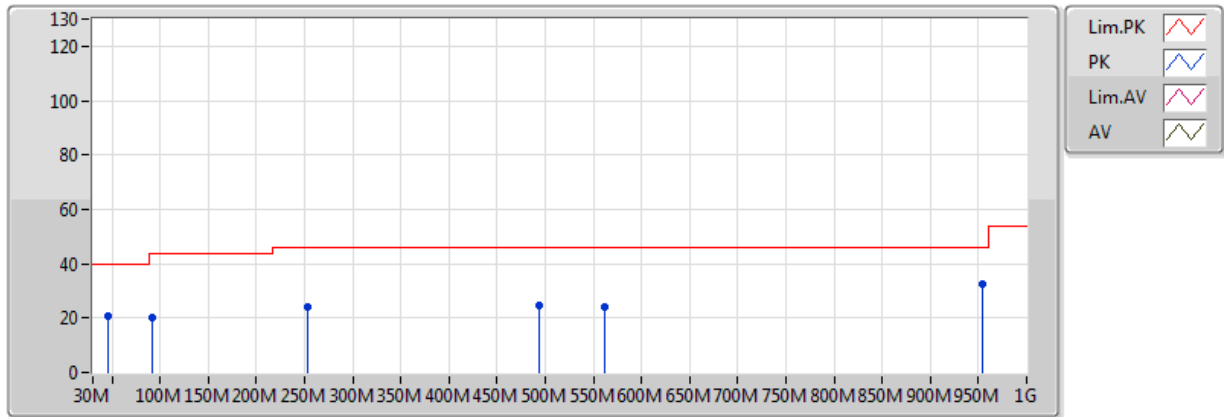

Type	Freq (Hz)	Level (dBuV/m)	Limit (dBuV/m)	Margin (dB)	Factor (dB)	Dist (m)	Condition	Azimuth (°)	Height (m)	Comments
PK	45.52M	20.91	40.00	-19.09	-21.27	3	Vertical	360	1.00	-
PK	92.08M	20.31	43.50	-23.19	-22.15	3	Vertical	360	1.00	-
PK	253.1M	24.30	46.00	-21.70	-16.68	3	Vertical	360	1.00	-
PK	493.66M	24.87	46.00	-21.13	-12.19	3	Vertical	360	1.00	-
PK	561.56M	24.00	46.00	-22.00	-10.34	3	Vertical	360	1.00	-
PK	953.44M	32.77	46.00	-13.23	-4.71	3	Vertical	360	1.00	-

BT-LE(1Mbps)

2440MHz_Battery

19/06/2018

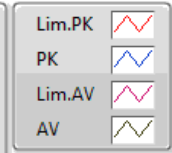
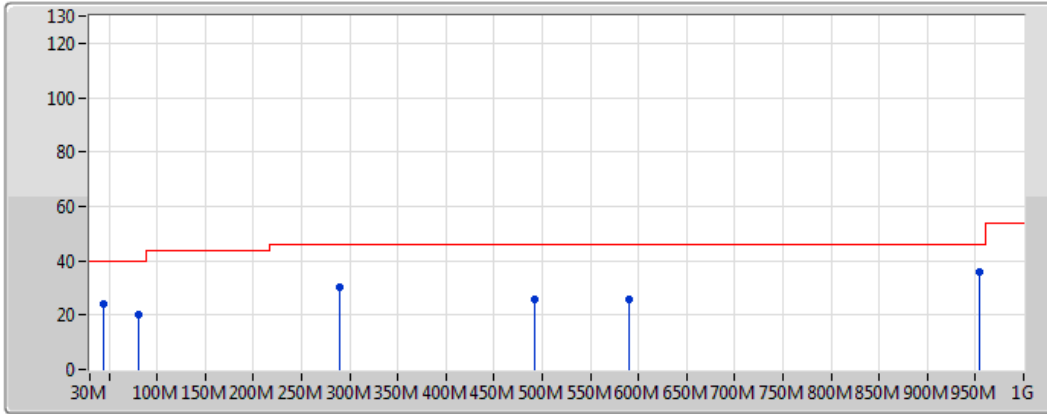

Type	Freq (Hz)	Level (dBuV/m)	Limit (dBuV/m)	Margin (dB)	Factor (dB)	Dist (m)	Condition	Azimuth (°)	Height (m)	Comments
PK	43.58M	24.28	40.00	-15.72	-20.25	3	Horizontal	0	1.00	-
PK	80.44M	19.94	40.00	-20.06	-23.85	3	Horizontal	0	1.00	-
PK	289.96M	30.14	46.00	-15.86	-16.89	3	Horizontal	0	1.00	-
PK	491.72M	25.99	46.00	-20.01	-12.21	3	Horizontal	0	1.00	-
PK	590.66M	25.57	46.00	-20.43	-10.95	3	Horizontal	0	1.00	-
PK	953.44M	36.09	46.00	-9.91	-4.71	3	Horizontal	0	1.00	-



Summary

Mode	Result	Type	Freq (Hz)	Level (dBuV/m)	Limit (dBuV/m)	Margin (dB)	Factor (dB)	Dist (m)	Condition	Azimuth (°)	Height (m)	Comments
2.4-2.4835GHz	-	-	-	-	-	-	-	-	-	-	-	-
BT-LE(1Mbps)	Pass	AV	2.483502G	53.76	54.00	-0.24	31.11	3	Vertical	359	1.50	-



Result

Mode	Result	Type	Freq (Hz)	Level (dBuV/m)	Limit (dBuV/m)	Margin (dB)	Factor (dB)	Dist (m)	Condition	Azimuth (°)	Height (m)	Comments
BT-LE(1Mbps)	-	-	-	-	-	-	-	-	-	-	-	-
2402MHz	Pass	AV	2.378G	49.72	54.00	-4.28	30.73	3	Vertical	203	1.58	-
2402MHz	Pass	AV	2.402G	107.77	Inf	-Inf	30.82	3	Vertical	203	1.58	-
2402MHz	Pass	PK	2.3778G	59.14	74.00	-14.86	30.73	3	Vertical	203	1.58	-
2402MHz	Pass	PK	2.4022G	108.11	Inf	-Inf	30.82	3	Vertical	203	1.58	-
2402MHz	Pass	AV	2.378G	46.89	54.00	-7.11	30.73	3	Horizontal	353	1.16	-
2402MHz	Pass	AV	2.402G	99.17	Inf	-Inf	30.82	3	Horizontal	353	1.16	-
2402MHz	Pass	PK	2.3894G	58.02	74.00	-15.98	30.77	3	Horizontal	353	1.16	-
2402MHz	Pass	PK	2.4018G	99.58	Inf	-Inf	30.82	3	Horizontal	353	1.16	-
2402MHz	Pass	AV	4.80352G	43.75	54.00	-10.25	2.08	3	Vertical	30	1.50	-
2402MHz	Pass	PK	4.8043G	49.67	74.00	-24.33	2.08	3	Vertical	30	1.50	-
2402MHz	Pass	AV	4.80352G	43.84	54.00	-10.16	2.08	3	Horizontal	30	1.40	-
2402MHz	Pass	PK	4.80436G	49.41	74.00	-24.59	2.08	3	Horizontal	30	1.40	-
2440MHz	Pass	AV	2.388G	46.55	54.00	-7.45	30.77	3	Vertical	197	1.56	-
2440MHz	Pass	AV	2.44G	109.53	Inf	-Inf	30.95	3	Vertical	197	1.56	-
2440MHz	Pass	AV	2.488G	47.51	54.00	-6.49	31.13	3	Vertical	197	1.56	-
2440MHz	Pass	PK	2.3472G	57.86	74.00	-16.14	30.62	3	Vertical	197	1.56	-
2440MHz	Pass	PK	2.4404G	109.91	Inf	-Inf	30.96	3	Vertical	197	1.56	-
2440MHz	Pass	PK	2.492G	58.18	74.00	-15.82	31.14	3	Vertical	197	1.56	-
2440MHz	Pass	AV	2.388G	46.41	54.00	-7.59	30.77	3	Horizontal	349	1.13	-
2440MHz	Pass	AV	2.44G	98.24	Inf	-Inf	30.95	3	Horizontal	349	1.13	-
2440MHz	Pass	AV	2.4984G	47.21	54.00	-6.79	31.17	3	Horizontal	349	1.13	-
2440MHz	Pass	PK	2.3556G	57.43	74.00	-16.57	30.66	3	Horizontal	349	1.13	-
2440MHz	Pass	PK	2.4396G	98.62	Inf	-Inf	30.95	3	Horizontal	349	1.13	-
2440MHz	Pass	PK	2.4884G	58.53	74.00	-15.47	31.13	3	Horizontal	349	1.13	-
2440MHz	Pass	AV	4.87946G	41.76	54.00	-12.24	2.27	3	Vertical	6	1.31	-
2440MHz	Pass	PK	4.88036G	48.37	74.00	-25.63	2.27	3	Vertical	6	1.31	-
2440MHz	Pass	AV	4.88036G	34.22	54.00	-19.78	2.27	3	Horizontal	6	1.53	-
2440MHz	Pass	PK	4.88708G	43.87	74.00	-30.13	2.29	3	Horizontal	6	1.53	-
2480MHz	Pass	AV	2.48G	106.97	Inf	-Inf	31.10	3	Vertical	359	1.50	-
2480MHz	Pass	AV	2.483502G	53.76	54.00	-0.24	31.11	3	Vertical	359	1.50	-
2480MHz	Pass	PK	2.4798G	107.38	Inf	-Inf	31.10	3	Vertical	359	1.50	-
2480MHz	Pass	PK	2.483502G	60.33	74.00	-13.67	31.11	3	Vertical	359	1.50	-
2480MHz	Pass	AV	2.48G	98.84	Inf	-Inf	31.10	3	Horizontal	353	1.00	-
2480MHz	Pass	AV	2.483502G	48.96	54.00	-5.04	31.11	3	Horizontal	353	1.00	-
2480MHz	Pass	PK	2.4798G	99.27	Inf	-Inf	31.10	3	Horizontal	353	1.00	-
2480MHz	Pass	PK	2.4926G	58.59	74.00	-15.41	31.14	3	Horizontal	353	1.00	-
2480MHz	Pass	AV	4.95952G	33.09	54.00	-20.91	2.47	3	Vertical	17	1.27	-
2480MHz	Pass	PK	4.97128G	45.29	74.00	-28.71	2.50	3	Vertical	17	1.27	-
2480MHz	Pass	AV	4.95958G	33.14	54.00	-20.86	2.47	3	Horizontal	78	1.99	-
2480MHz	Pass	PK	4.96024G	44.30	74.00	-29.70	2.47	3	Horizontal	78	1.99	-

BT-LE(1Mbps)

2402MHz_TX

19/06/2018

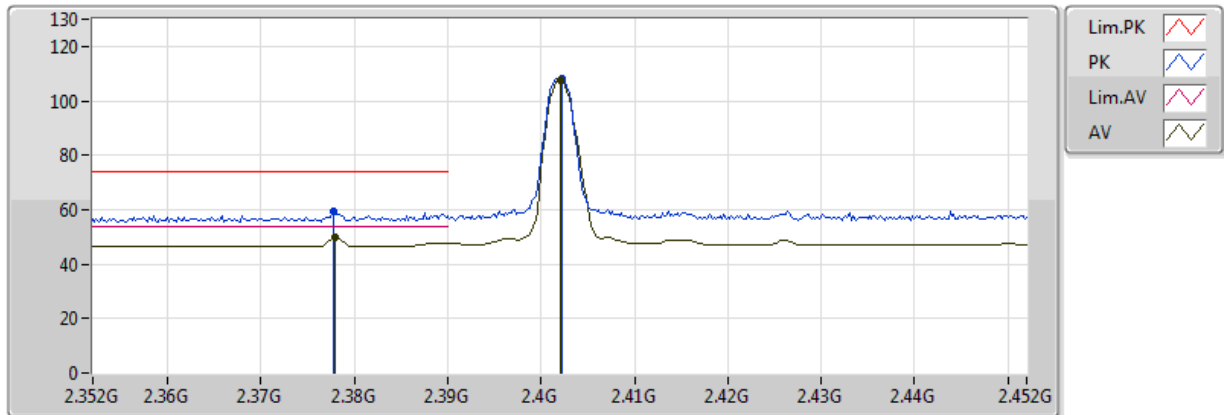

Type	Freq (Hz)	Level (dBuV/m)	Limit (dBuV/m)	Margin (dB)	Factor (dB)	Dist (m)	Condition	Azimuth (°)	Height (m)	Comments
AV	2.378G	49.72	54.00	-4.28	30.73	3	Vertical	203	1.58	-
AV	2.402G	107.77	Inf	-Inf	30.82	3	Vertical	203	1.58	-
PK	2.3778G	59.14	74.00	-14.86	30.73	3	Vertical	203	1.58	-
PK	2.4022G	108.11	Inf	-Inf	30.82	3	Vertical	203	1.58	-

BT-LE(1Mbps)

2402MHz_TX

19/06/2018

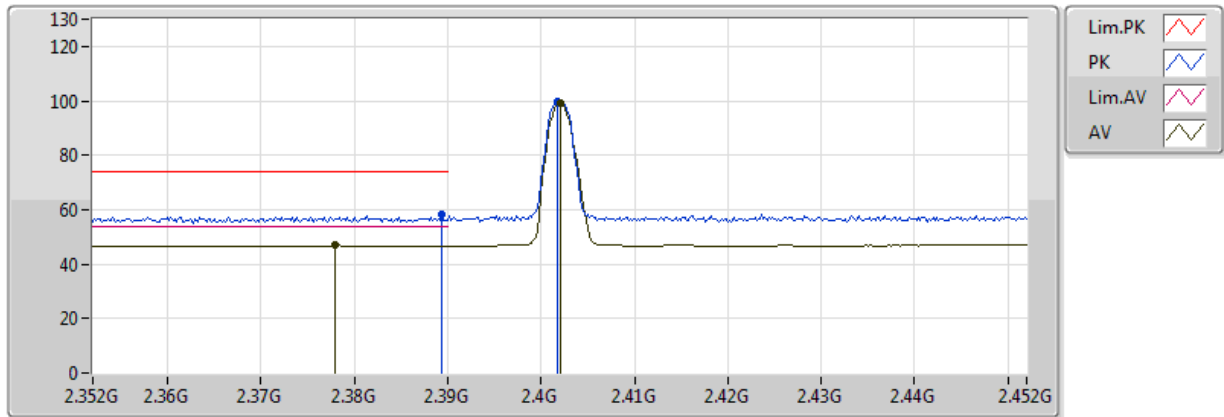

Type	Freq (Hz)	Level (dBuV/m)	Limit (dBuV/m)	Margin (dB)	Factor (dB)	Dist (m)	Condition	Azimuth (°)	Height (m)	Comments
AV	2.378G	46.89	54.00	-7.11	30.73	3	Horizontal	353	1.16	-
AV	2.402G	99.17	Inf	-Inf	30.82	3	Horizontal	353	1.16	-
PK	2.3894G	58.02	74.00	-15.98	30.77	3	Horizontal	353	1.16	-
PK	2.4018G	99.58	Inf	-Inf	30.82	3	Horizontal	353	1.16	-

BT-LE(1Mbps)

2402MHz_TX

19/06/2018

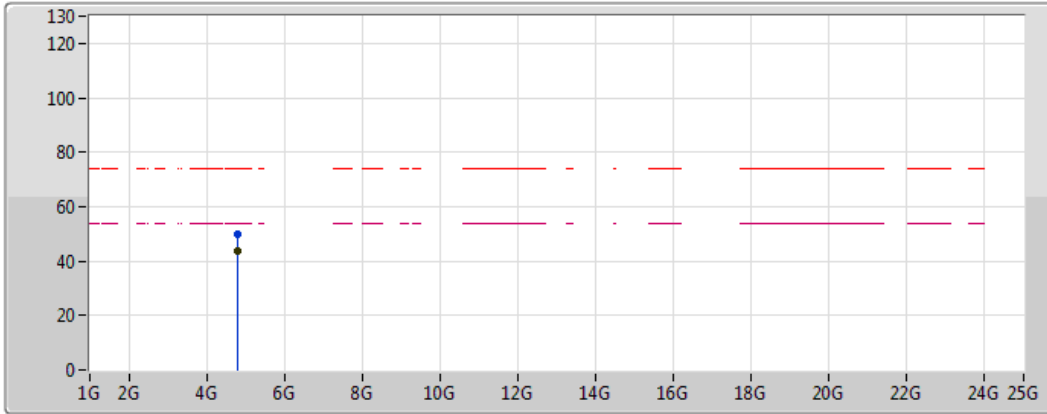

Type	Freq (Hz)	Level (dBuV/m)	Limit (dBuV/m)	Margin (dB)	Factor (dB)	Dist (m)	Condition	Azimuth (°)	Height (m)	Comments
AV	4.80352G	43.75	54.00	-10.25	2.08	3	Vertical	30	1.50	-
PK	4.8043G	49.67	74.00	-24.33	2.08	3	Vertical	30	1.50	-

BT-LE(1Mbps)

2402MHz_TX

19/06/2018

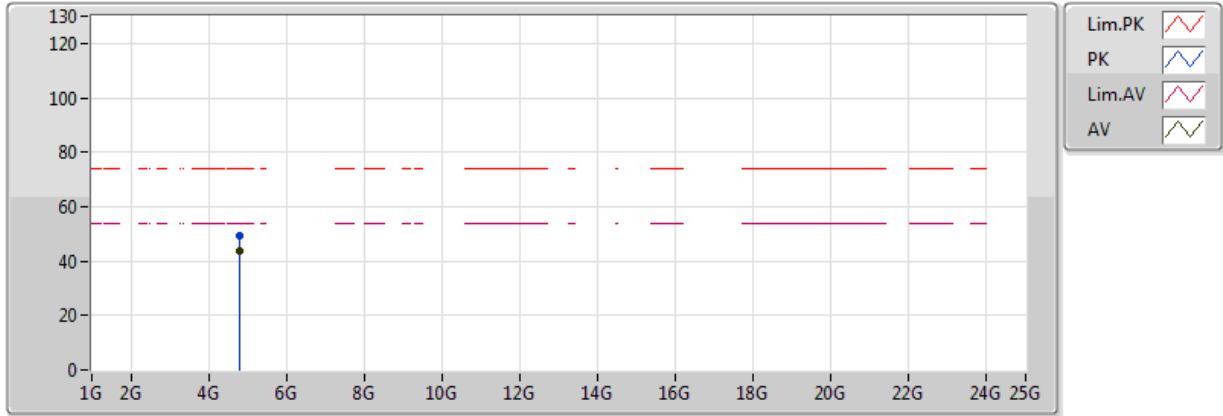

Type	Freq (Hz)	Level (dBuV/m)	Limit (dBuV/m)	Margin (dB)	Factor (dB)	Dist (m)	Condition	Azimuth (°)	Height (m)	Comments
AV	4.80352G	43.84	54.00	-10.16	2.08	3	Horizontal	30	1.40	-
PK	4.80436G	49.41	74.00	-24.59	2.08	3	Horizontal	30	1.40	-

BT-LE(1Mbps)

2440MHz_TX

19/06/2018

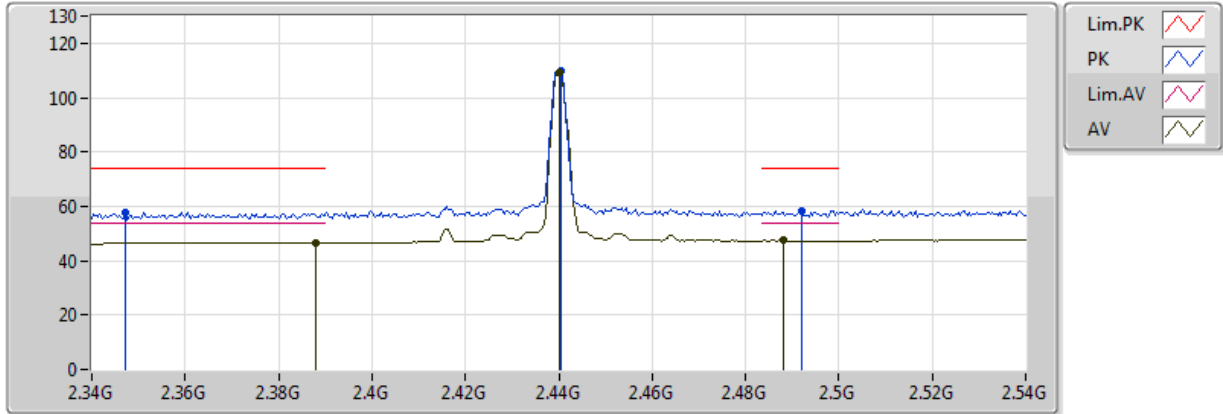

Type	Freq (Hz)	Level (dBuV/m)	Limit (dBuV/m)	Margin (dB)	Factor (dB)	Dist (m)	Condition	Azimuth (°)	Height (m)	Comments
AV	2.388G	46.55	54.00	-7.45	30.77	3	Vertical	197	1.56	-
AV	2.44G	109.53	Inf	-Inf	30.95	3	Vertical	197	1.56	-
AV	2.488G	47.51	54.00	-6.49	31.13	3	Vertical	197	1.56	-
PK	2.3472G	57.86	74.00	-16.14	30.62	3	Vertical	197	1.56	-
PK	2.4404G	109.91	Inf	-Inf	30.96	3	Vertical	197	1.56	-
PK	2.492G	58.18	74.00	-15.82	31.14	3	Vertical	197	1.56	-

BT-LE(1Mbps)

2440MHz_TX

19/06/2018

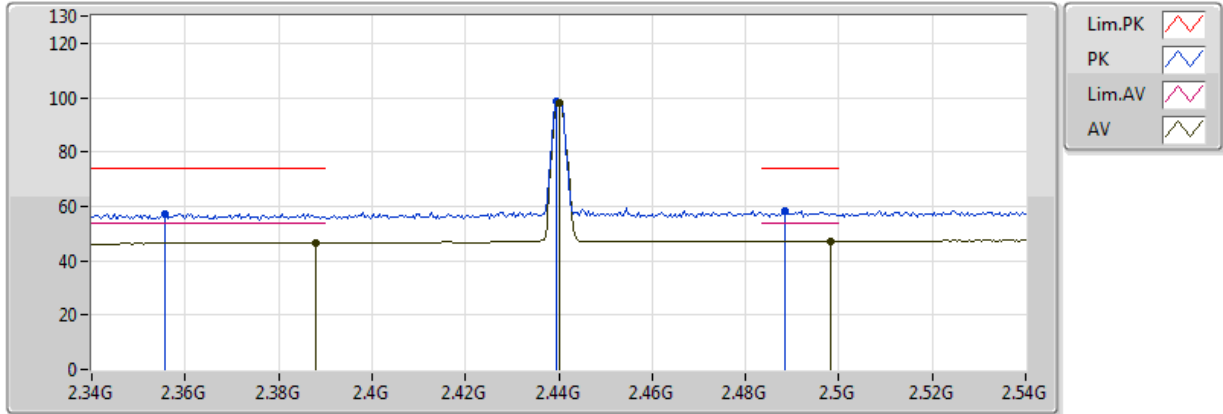

Type	Freq (Hz)	Level (dBuV/m)	Limit (dBuV/m)	Margin (dB)	Factor (dB)	Dist (m)	Condition	Azimuth (°)	Height (m)	Comments
AV	2.388G	46.41	54.00	-7.59	30.77	3	Horizontal	349	1.13	-
AV	2.44G	98.24	Inf	-Inf	30.95	3	Horizontal	349	1.13	-
AV	2.4984G	47.21	54.00	-6.79	31.17	3	Horizontal	349	1.13	-
PK	2.3556G	57.43	74.00	-16.57	30.66	3	Horizontal	349	1.13	-
PK	2.4396G	98.62	Inf	-Inf	30.95	3	Horizontal	349	1.13	-
PK	2.4884G	58.53	74.00	-15.47	31.13	3	Horizontal	349	1.13	-

BT-LE(1Mbps)

2440MHz_TX

19/06/2018

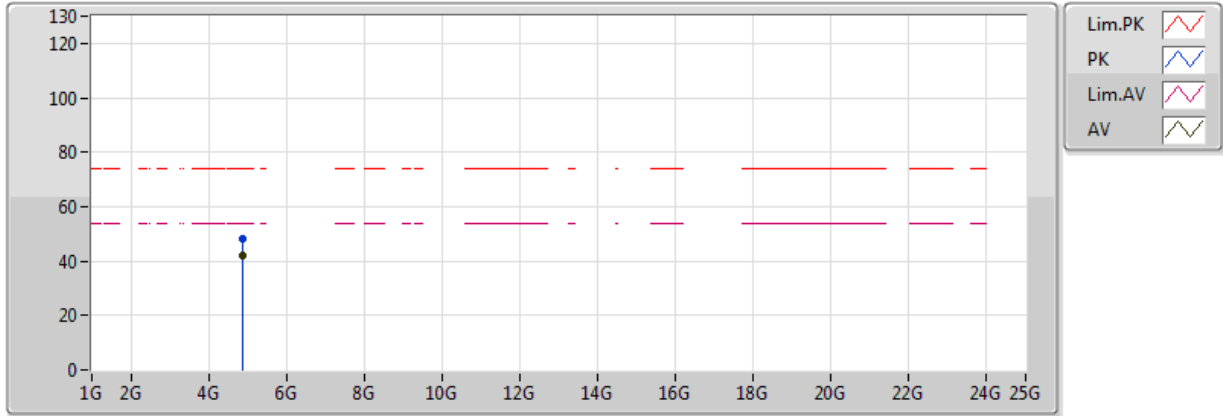

Type	Freq (Hz)	Level (dBuV/m)	Limit (dBuV/m)	Margin (dB)	Factor (dB)	Dist (m)	Condition	Azimuth (°)	Height (m)	Comments
AV	4.87946G	41.76	54.00	-12.24	2.27	3	Vertical	6	1.31	-
PK	4.88036G	48.37	74.00	-25.63	2.27	3	Vertical	6	1.31	-

BT-LE(1Mbps)

2440MHz_TX

19/06/2018

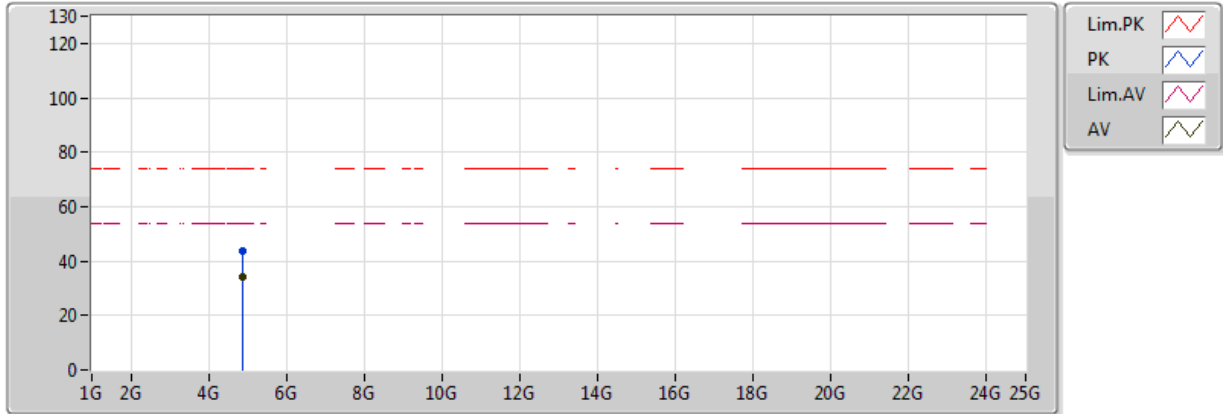

Type	Freq (Hz)	Level (dBuV/m)	Limit (dBuV/m)	Margin (dB)	Factor (dB)	Dist (m)	Condition	Azimuth (°)	Height (m)	Comments
AV	4.88036G	34.22	54.00	-19.78	2.27	3	Horizontal	6	1.53	-
PK	4.88708G	43.87	74.00	-30.13	2.29	3	Horizontal	6	1.53	-



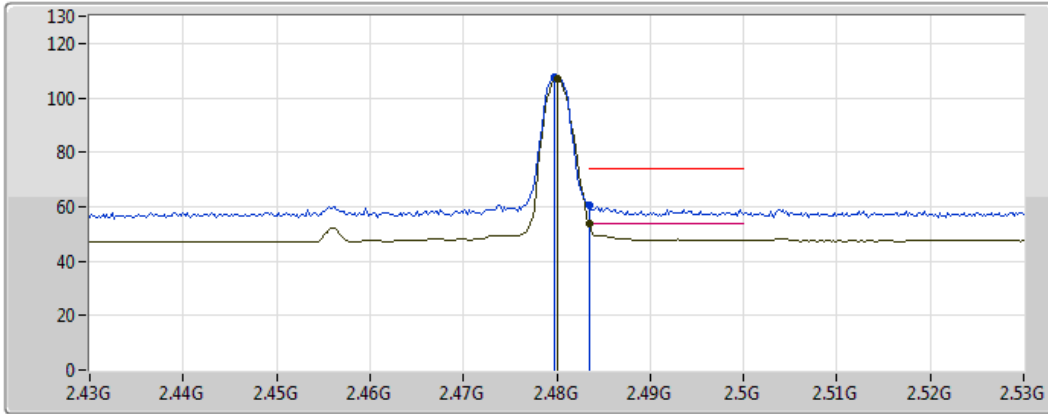

BT-LE(1Mbps)

2480MHz_TX

19/06/2018



Legend for the spectrum plot:

- Lim.PK 
- PK 
- Lim.AV 
- AV 

Type	Freq (Hz)	Level (dBuV/m)	Limit (dBuV/m)	Margin (dB)	Factor (dB)	Dist (m)	Condition	Azimuth (°)	Height (m)	Comments
AV	2.48G	106.97	Inf	-Inf	31.10	3	Vertical	359	1.50	-
AV	2.483502G	53.76	54.00	-0.24	31.11	3	Vertical	359	1.50	-
PK	2.4798G	107.38	Inf	-Inf	31.10	3	Vertical	359	1.50	-
PK	2.483502G	60.33	74.00	-13.67	31.11	3	Vertical	359	1.50	-

BT-LE(1Mbps)

2480MHz_TX

19/06/2018

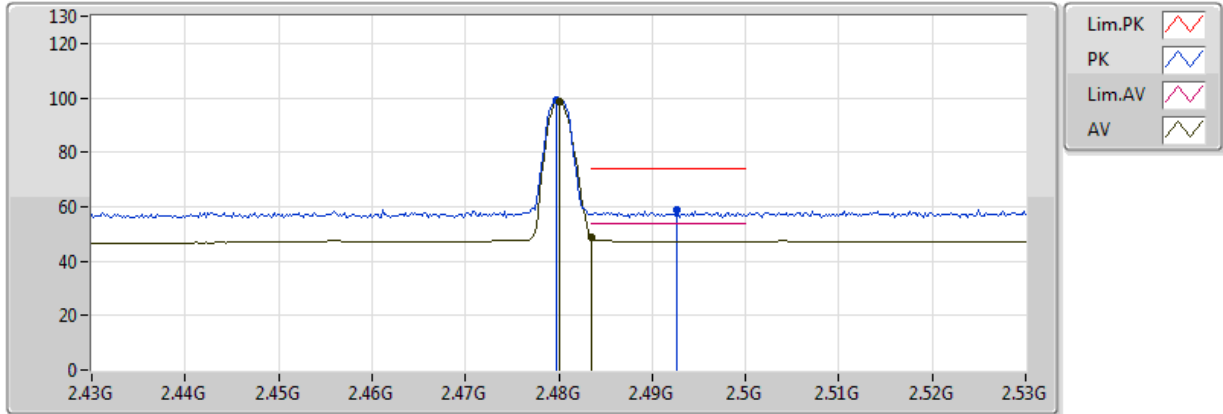

Type	Freq (Hz)	Level (dBuV/m)	Limit (dBuV/m)	Margin (dB)	Factor (dB)	Dist (m)	Condition	Azimuth (°)	Height (m)	Comments
AV	2.48G	98.84	Inf	-Inf	31.10	3	Horizontal	353	1.00	-
AV	2.483502G	48.96	54.00	-5.04	31.11	3	Horizontal	353	1.00	-
PK	2.4798G	99.27	Inf	-Inf	31.10	3	Horizontal	353	1.00	-
PK	2.4926G	58.59	74.00	-15.41	31.14	3	Horizontal	353	1.00	-

BT-LE(1Mbps)

2480MHz_TX

19/06/2018

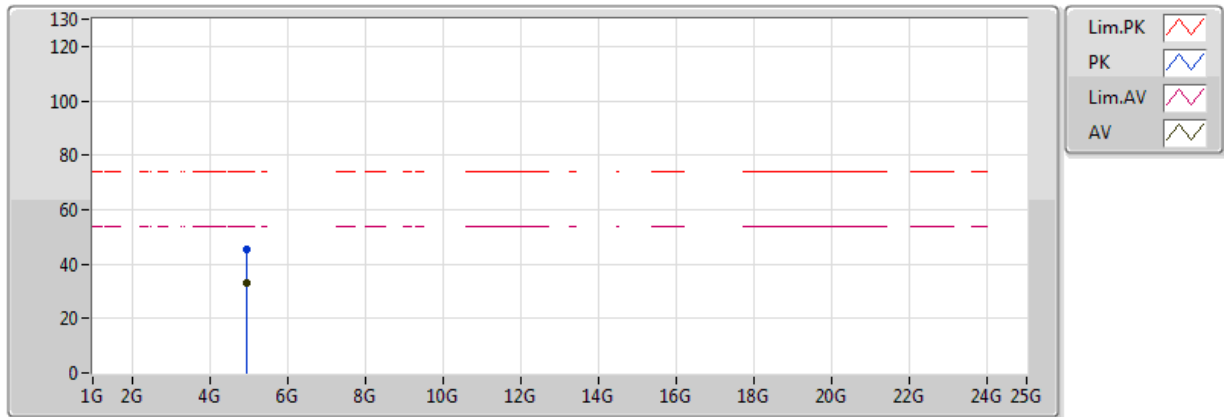

Type	Freq (Hz)	Level (dBuV/m)	Limit (dBuV/m)	Margin (dB)	Factor (dB)	Dist (m)	Condition	Azimuth (°)	Height (m)	Comments
AV	4.95952G	33.09	54.00	-20.91	2.47	3	Vertical	17	1.27	-
PK	4.97128G	45.29	74.00	-28.71	2.50	3	Vertical	17	1.27	-

BT-LE(1Mbps)

2480MHz_TX

19/06/2018

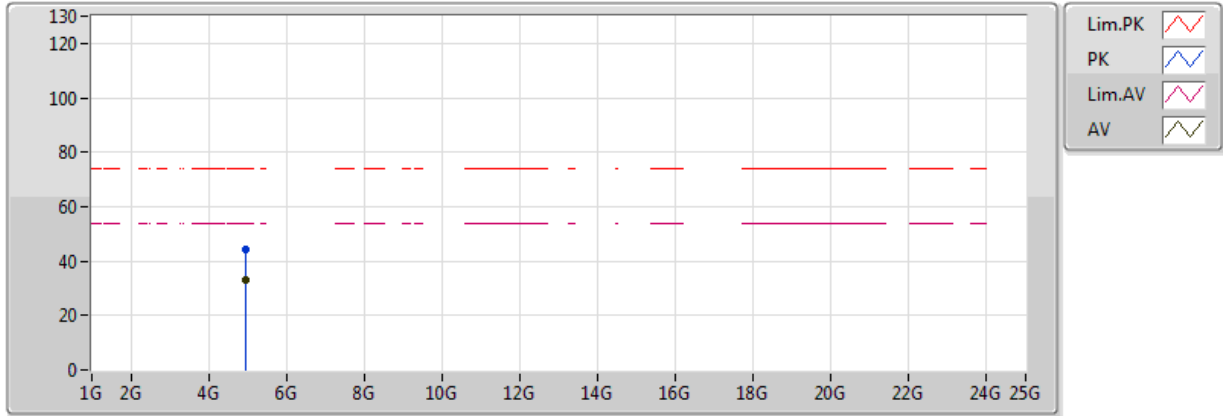

Type	Freq (Hz)	Level (dBuV/m)	Limit (dBuV/m)	Margin (dB)	Factor (dB)	Dist (m)	Condition	Azimuth (°)	Height (m)	Comments
AV	4.95958G	33.14	54.00	-20.86	2.47	3	Horizontal	78	1.99	-
PK	4.96024G	44.30	74.00	-29.70	2.47	3	Horizontal	78	1.99	-