

WS020T Integrated Outdoor Sensor User Manual

1. Introduction

Thank you for your purchase of the Integrated Outdoor Sensor. The following user guide provides step by step instructions for installation, operation and troubleshooting.

2. Warnings

⚠ Warning: Any metal object may attract a lightning strike, including your weather station mounting pole. Never install the weather station in a storm.



⚠ Warning: Installing your weather station in an elevated location may result in injury or death. Safety goes first. Make sure your setup and preparation is secure, and take no risks.

3. Getting Started

Integrated Outdoor Transmitter and mounting hardware

3.1 Parts List

Integrated Outdoor Sensor consists of the following parts (as referenced in Figure 1).

QTY	Item	Image
1	Integrated Outdoor Transmitter Dimensions (LxHxW) : 330x150x280mm	
1	Foot Mounting (with pole insert) Dimensions: 101x 76 x 32mm	
1	Mounting Bracket Back Plate (pole mount) Dimensions: 76 x 102 x 38mm	





1	Mounting Pole Dimensions: 300 x 300 x 20mm	
2	Pole mounting nuts (M3) / bolts Ø3)	
4	Pole mounting nuts (M5) / bolts (Ø5)	
4	Tapping screws	
1	Manual	

Figure 1

3.2 Recommend Tools

- Precision screwdriver (for small Phillips screws)
- Compass or GPS (for wind direction calibration)
- Adjustable Wrench
- Hammer and nail for Foot Mounting.

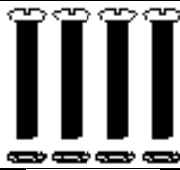
3.3 Sensor Assembly Set Up

The following illustration shows the full segment for Thermo-Hygrometer, WIND and RAIN transmitter .purposes only , as shown in Figure 2.

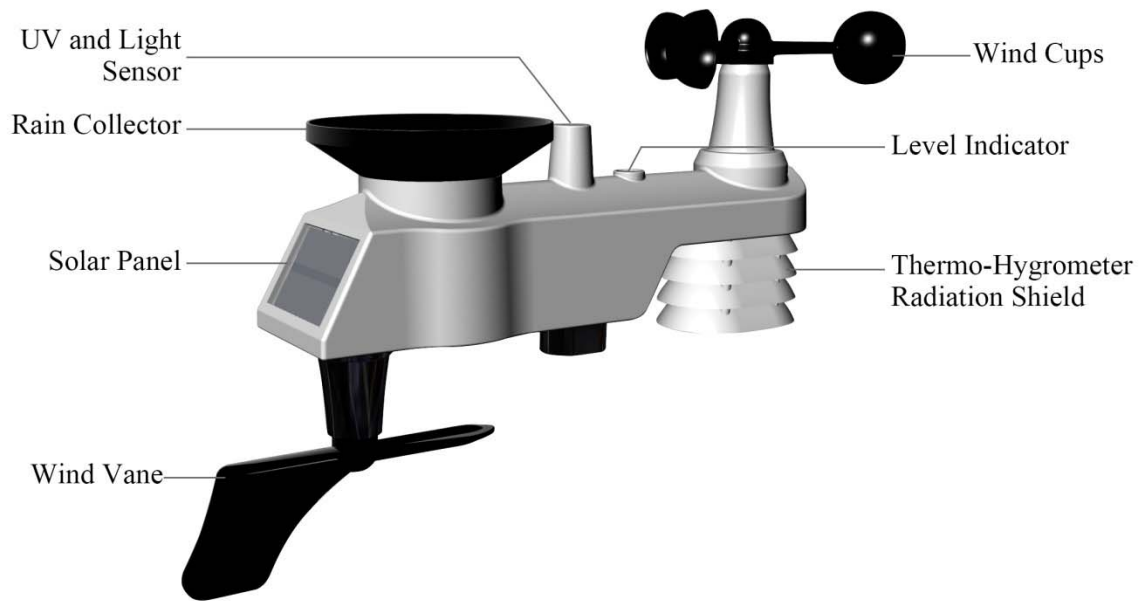

Figure 2

3.3.1 Insert batteries into the transmitter. Locate the battery door on the transmitter, push and open the battery compartment, as show in Figure 3.

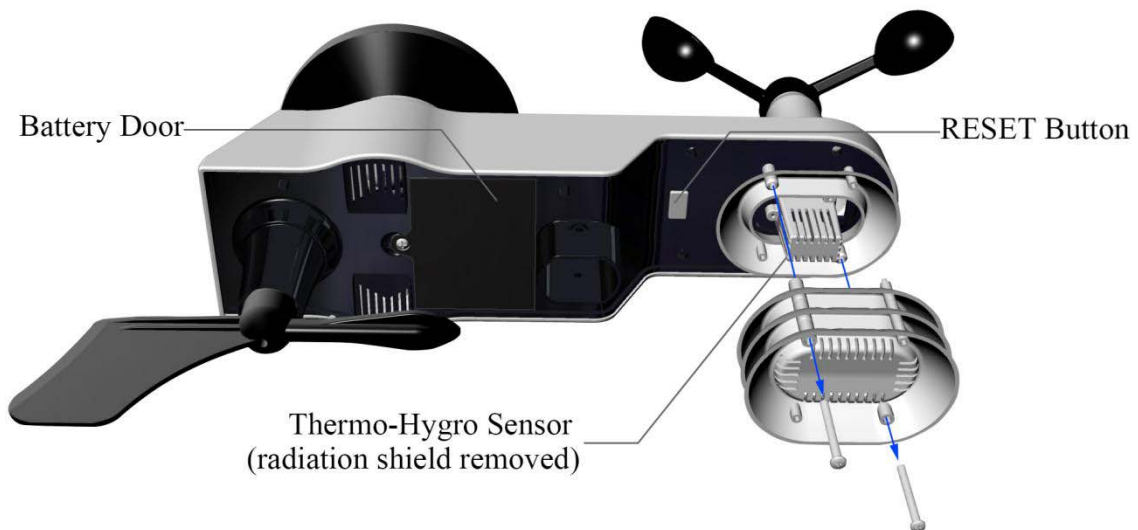

Figure 3

Remove the battery door on the back of the sensor by removing the set screw, as shown in Figure 4.



Figure 4

Inserting 3xAA batteries in the battery compartment, as show in Figure 5.



Figure 5

Close the battery cover. Make sure the gasket (around the battery compartment) is properly seated in its place prior to closing the door. Tighten the set screw.

 **Note:** Do not install the batteries backwards. You can permanently damage the sensors. The solar panel does not charge the batteries, so rechargeable batteries are not needed or recommended.

 **Note:** We recommend installing Lithium AA batteries for sensors. The sensor LED indicator will light for 3 seconds, and then flash once per 16 seconds thereafter. Each time it flashes, the sensor is transmitting data. Place the battery cover and push it to close the compartment.

 **Note:** If the sensor does not power up after inserting the batteries, press the reset button shown in Figure 6.

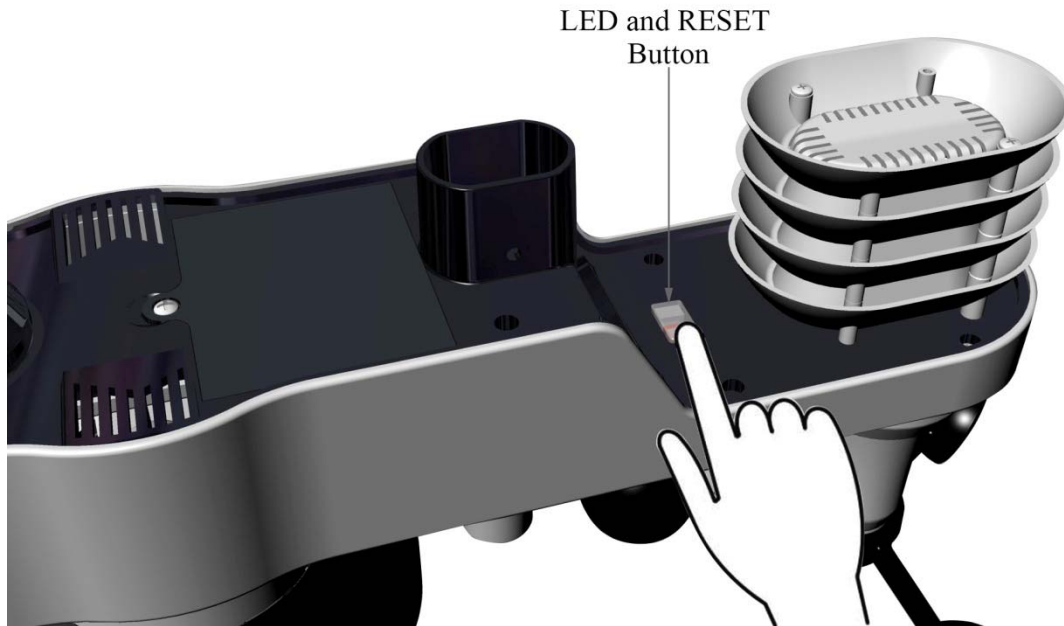

Figure 6

3.4.2 Sensor Operation Verification

The following steps verify proper operation of the sensors prior to installing the sensor array.

1. Verify proper operation of the rain gauge. Tip the sensor array back and forth several times. You should hear a “clicking” sound within the rain gauge. Verify the rain reading on data is not reading 0.00. Each “click” represents 0.3mm of rainfall.
2. Verify proper operating of the wind speed. Rotate the wind cups manually or with a constant speed fan. Verify the wind speed is not reading 0.0.

4. Integrated outdoor Sensor Installation

4.1 Pre Installation Check. Before installing your Integrated outdoor Sensor in the permanent location, we recommend operating the weather station for one week in a temporary location with easy access. This will allow you to check out all of the functions, insure proper operation, and familiarize you with the weather station and calibration procedures.

Fasten the integrated transmitter to mounting pole brackets with foot-mounting, two ϕ 3 bolts and M3 nuts , as shown in Figure 8



Figure 8

Tighten the mounting pole to your mounting pole(purchased separately) with the four $\phi 5$ Bolts and M5 Nuts assembly, or fix on the wall with four tapping screw, as shown in Figure9.



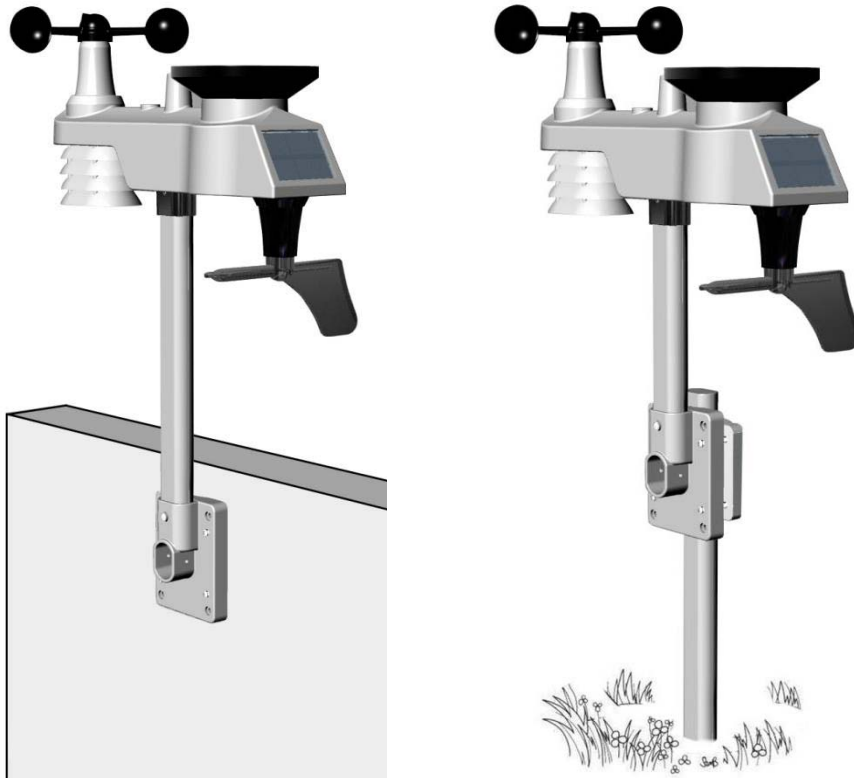

Figure 9

5. Low Battery Icon

A low battery indicator icon is shown in the display window for Integrated outdoor transmitter. When the low battery icon appears (the battery voltage is lower than 3.6V), replace the batteries in the sensor with fresh batteries. Be sure to never mix old and new batteries, and never mix battery types such as alkaline and lithium together.

6.Specifications

6.1 Wire Specifications

- Distance of Data Line : 0.5m.
- Pin: 4
- Integrated Outdoor transmitter interval: 16 seconds

6.2 Measurement Specifications

The following table provides specifications for the measured parameters.

Measurement	Range	Accuracy	Resolution
Outdoor Temperature	-40 to 60 °C	± 1 °C	0.1 °C
Outdoor Humidity	10 to 99%	± 5% (only guaranteed between 20 to 90%)	1 %
UV Index	1 to 15+	± 1	± 1
Sunlight	0 to 200klux	± 15%	± 15%
Rain	0 to 6553.5 mm	<15mm:±1 mm, 15mm to 6553.5 mm:±7%	<1000mm (0.3mm) >1000mm (1mm)
Wind Direction	0 - 360 °	45° (8 point compass)	45° (8 point compass)
Wind Speed	0 to 50 m/s	2 m/s ~10 m/s: ±3m/s, 10m/s ~50 m/s: ±10% (whichever is greater)	0.1 m/s

6.3 Power Consumption

- Integrated Outdoor Transmitter: 3xAAA alkaline batteries or Lithium batteries (not included)
- Battery life:
Minimum 12 months for Integrated Outdoor Transmitter (use lithium batteries in cold weather climates less than -20 °C), The primary power source is the solar panel. The batteries provide backup power when there is limited solar energy

7.Maintenance

1. Clean the rain gauge and wind transmitter once every 3 months.
 - Unscrew the rain collector funnel by turning it 30° counter clockwise.
 - Gently remove the rain collector funnel.
 - Clean and remove any debris or insects.
 - Install the collector funnel after it has been cleaned and completely dried.

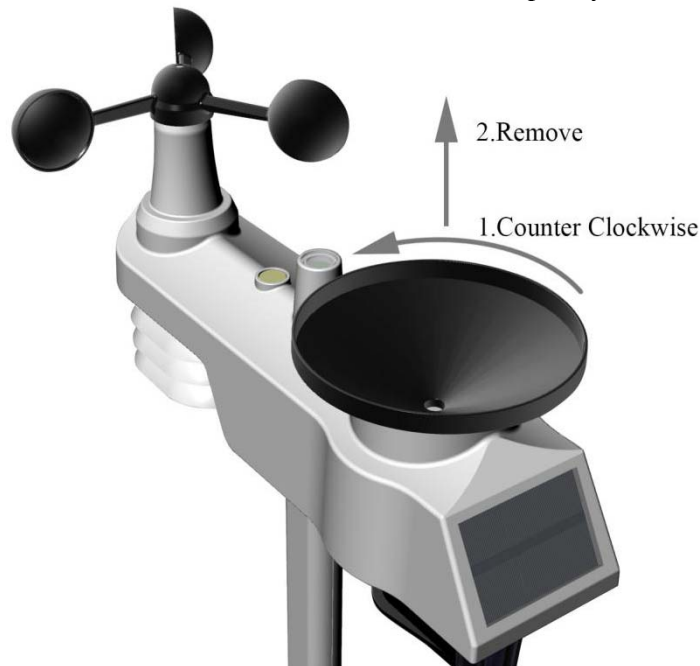

Figure 58

2. Replace the wind, rain and thermo-hygrometer transmitter batteries once every 1-2 years

8 Troubleshooting Guide.

Problem	Solution
Outdoor Temperature do not agree	Allow up to one hour for the sensors to stabilize due to signal filtering. A known source and outdoor temperature sensors should agree within 2 °C (the sensor accuracy is ± 1 °C).
Outdoor Humidity do not agree	Allow up to one hour for the sensors to stabilize due to signal filtering. A known source and outdoor humidity sensors should agree within 10 % (the sensor accuracy is ± 5 %).

FCC Statement

Statement according to FCC part 15.19:

This device complies with part 15 of the FCC rules. Operation is subject to the following two conditions:

1. This device may not cause harmful interference.
2. This device must accept any interference received, including interference that may cause undesired operation.

Statement according to FCC part 15.21:

Modifications not expressly approved by this company could void the user's authority to operate the equipment.

Statement according to FCC part 15.105:

NOTE: This equipment has been tested and found to comply with the limits for a Class B digital device, pursuant to Part 15 of the FCC Rules. These limits are designed to provide reasonable protection against harmful interference in a residential installation. This equipment generates, uses and can radiate radio frequency energy and, if not installed and used in accordance with the instructions, may cause harmful interference to radio communications.

However, there is no guarantee that interference will not occur in a particular installation.

If this equipment does cause harmful interference to radio or television reception, which can be determined by turning the equipment off and on, the user is encouraged to try to correct the interference by one or more of the following measures:

- Reorient or relocate the receiving antenna.
- Increase the separation between the equipment and receiver.
- Connect the equipment into an outlet on a circuit different from that to which the receiver is connected.
- Consult the dealer or an experienced radio/TV technician for help.