

User manual

RT-A300FT PRESTO (Wireless charging PAD)

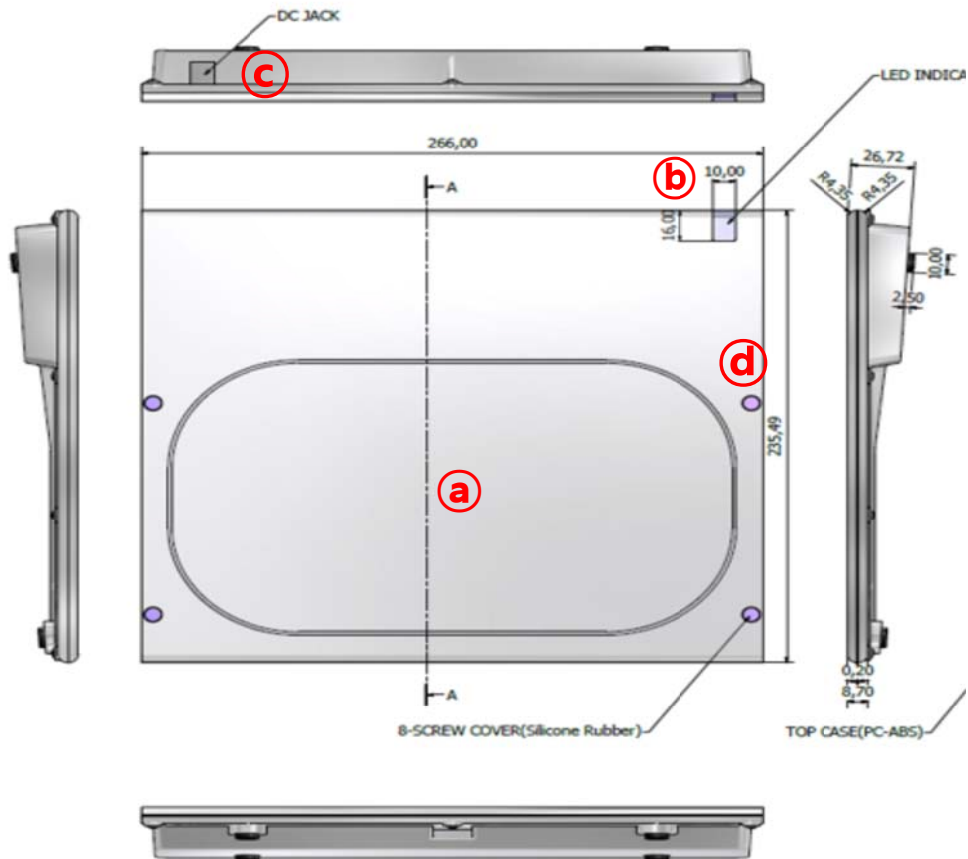

Package Contents:

Check your package for the follow items:

- RT-A300FT PTU
- 36V Adapter
- User Manual

Device layout

a	Charging area	b	LED indicator
c	DC jack	d	Screw

Wireless design

- Technology AFA-resonant CLASS4
- Power AFA CLASS4 33W delivered to receiving device.
- Input power 36V DC adapter
- X-Y dimension 266mm * 235.49mm

LED behavior

There is one LED that indicates operation states.

LED STATUS	LED
Unplugged	Off
On / Ready (STAND-BY)	FLASH GREEN
Charging	SOLID GREEN
Charge complete	FLASH GREEN
Error condition	SOLID RED

Use of the wireless charging pad

- The wireless charging PAD is mainly to charge a small wearable device, smart phones, phablet or small laptop.
- Connect the traveler adapter to the wireless charging PAD, followed by the insertion of the adapter into wall outlet, and then place AFA-enabled device or devices onto the charging area designated on the wireless charging pad.
- Check that the LED located at the upper right corner flashes green periodically in the conditions under which no loads are applied to the PTU after or before a power source is applied to the PTU device.
- Check that the LED located at the upper right corner remains green without blinking when an AFA-enabled device is placed on the charging pad of PTU.

- When LED turn red, make sure that the adapter is removed and re-plugged in.
- When LED remains red, pls consult with the shop where it was bought.
- When they are fully charged, remove them from the charging area.

Disclaimer

- Pls read this manual before using the wireless charging pad for a proper use.
- The image shown above may differ in appearance from the actual device.
The contents on the manual is subject to change without prior notice.

This equipment has been found to comply with FCC RF radiation exposure limits set forth for an uncontrolled environment that users is commonly exposed to.

This equipment should be installed and operated with the minimum distance between the radiator and your body kept separated from more than 10cm.



While a laptop is placed on a charging mat, it is recommended being not used.

This device complies with part 15 of the FCC rules. Operation is subject to the following two conditions: (1) this device may not cause harmful interference, and (2) this device must accept any interference received, including interference that may cause undesired operation.

NOTE: The manufacturer is not responsible for any radio or TV interference caused by unauthorized modifications to this equipment. Such modifications could void the user's authority to operate the equipment.

NOTE: This equipment has been tested and found to comply with the limits for a

Class B digital device, pursuant to part 15 of the FCC Rules. These limits are designed to provide reasonable protection against harmful interference in a residential installation.

This equipment generates and can radiate radio frequency energy and, if not installed and used in accordance with the instructions, may cause harmful interference to radio communications. However, there is no guarantee that interference will not occur in a particular installation. If this equipment does cause harmful interference to radio or television reception, which can be determined by turning the equipment off and on, the user is encouraged to try to correct the interference by one or more of the following measures:

- Reorient or relocate the receiving antenna.
- Increase or decrease the separation between the equipment and receiver.
- Connect the equipment into an outlet on a circuit different from that to which the receiver is connected.
- Consult the dealer or an experienced radio/TV technician for help

- This device and its antenna(s) must not be co-located or operating in conjunction with any other antenna or transmitter.