

FCC Test Report

FCC ID: 2ALH2-PFAV100

Product: PIQS Virtual Touch Projector
Trade Mark: PIQS
Model Number: V
Serial Model: N/A
Report No.: NTEK-2017NT08266058F4

Prepared for

PIQS Technology(Shenzhen) Limited
West,6F Buiding 1, No.35 CuiJing Road, Pingshan New District,
Shenzhen City, Guangdong Province, P.R.China

Prepared by

Shenzhen NTEK Testing Technology Co., Ltd.
1/F, Building E, Fenda Science Park, Sanwei Community,
Xixiang Street Bao'an District, Shenzhen P.R. China
Tel.: +86-755-6115 9388
Fax.: +86-755-6115 6599
Website:<http://www.ntek.org.cn>

TEST RESULT CERTIFICATION

Applicant's name : PIQS Technology(Shenzhen) Limited
Address..... : West,6F Buiding 1, No.35 CuiJing Road, Pingshan New District,
Shenzhen City, Guangdong Province, P.R.China

Manufacturer's Name : Butterfly technology(Shenzhen) Limited
Address..... : East, 6F Buiding 1, No.35 CuiJing Road, Pingshan New
District, Shenzhen City, Guangdong Province, P.R.China

Product description

Product name..... : PIQS Virtual Touch Projector

Model and/or type reference : V

Standards : FCC Part15B
ANSI C63.4:2014

This device described above has been tested by NTEK, and the test results show that the equipment under test (EUT) is in compliance with Part 15 of FCC Rules. And it is applicable only to the tested sample identified in the report.

This report shall not be reproduced except in full, without the written approval of NTEK, this document may be altered or revised by NTEK, personnel only, and shall be noted in the revision of the document.

Date of Test

Date (s) of performance of tests..... : 26 Aug. 2017 ~ 29 Sep. 2017

Date of Issue : 29 Sep. 2017

Test Result..... : **Pass**

Testing Engineer :



(Allen Liu)

Technical Manager :



(Jason Chen)

Authorized Signatory :

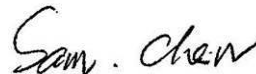

(Sam Chen)

Table of Contents**Page**

| | |
|--|----|
| 1 . TEST SUMMARY | 4 |
| 1.1 TEST FACILITY | 5 |
| 1.2 MEASUREMENT UNCERTAINTY | 5 |
| 2 . GENERAL INFORMATION | 6 |
| 2.1 GENERAL DESCRIPTION OF EUT | 6 |
| 2.2 DESCRIPTION TEST PERIPHERAL AND EUT PERIPHERAL | 10 |
| 2.3 MEASUREMENT INSTRUMENTS LIST | 11 |
| 3 . EMC EMISSION TEST | 12 |
| 3.1 CONDUCTED EMISSION MEASUREMENT | 12 |
| 3.1.1 POWER LINE CONDUCTED EMISSION | 12 |
| 3.1.2 TEST PROCEDURE | 13 |
| 3.1.3 TEST SETUP | 13 |
| 3.1.4 EUT OPERATING CONDITIONS | 13 |
| 3.1.5 TEST RESULTS | 14 |
| 3.2 RADIATED EMISSION MEASUREMENT | 18 |
| 3.2.1 LIMITS OF RADIATED EMISSION MEASUREMENT | 18 |
| 3.2.2 TEST PROCEDURE | 18 |
| 3.2.3 TEST SETUP | 19 |
| 3.2.4 TEST RESULTS | 20 |
| 3.2.5 TEST RESULTS(1000~6000MHz) | 22 |

1. TEST SUMMARY

Test procedures according to the technical standards:

| EMC Emission | | | | |
|---------------------------------|--------------------|---------|----------|--------|
| Standard | Test Item | Limit | Judgment | Remark |
| FCC Part15B ANSI C63.4: 2014 | Conducted Emission | Class B | PASS | |
| | Radiated Emission | Class B | PASS | |

NOTE:

- (1) 'N/A' denotes test is not applicable in this Test Report
- (2) For client's request and manual description, the test will not be executed.

1.1 TEST FACILITY

Shenzhen NTEK Testing Technology Co., Ltd
 Add. : 1/F, Building E, Fenda Science Park, Sanwei Community, Xixiang Street, Bao'an District, Shenzhen 518126 P.R. China.
 FCC Registration Number:463705; IC Registration Number:9270A-1
 CNAS Registration Number:L5516

1.2 MEASUREMENT UNCERTAINTY

The reported uncertainty of measurement $y \pm U$, where expanded uncertainty U is based on a standard uncertainty multiplied by a coverage factor of $k=2$, providing a level of confidence of approximately **95 %**.

A. Conducted Measurement :

| Test Site | Method | Measurement Frequency Range | U, (dB) | NOTE |
|-----------|--------|-----------------------------|---------|------|
| NTEKC01 | ANSI | 150 KHz ~ 30MHz | 3.2 | |

B. Radiated Measurement :

| Test Site | Method | Measurement Frequency Range | U, (dB) | NOTE |
|-----------|--------|-----------------------------|---------|------|
| NTEKA01 | ANSI | 30MHz ~ 1000MHz | 4.7 | |
| | | 1GHz ~12.4GHz | 5.0 | |

2. GENERAL INFORMATION

2.1 GENERAL DESCRIPTION OF EUT

| | | |
|---------------------|---|---|
| Equipment | PIQS Virtual Touch Projector | |
| Trade Mark | PIQS | |
| Model Name | V | |
| Serial Model | N/A | |
| Model Difference | N/A | |
| Product Description | The EUT is a PIQS Virtual Touch Projector. | |
| | Connecting I/O port: | USB, HDMI, LAN, Headphone port, Fiber port |
| | Operation Frequency: | BT:2402~2480 MHz WIFI:802.11b/g/n20:2412~2462MHz 5180-5240MHz for 802.11a/n(HT20)/ac20; 5190-5230MHz for 802.11n(HT40)/ac40; 5210MHz for 802.11 ac80; 5745-5825 MHz for 802.11a/n(HT20)/ac20; 5755-5795 MHz for 802.11a/n(HT40)/ac40; 5775MHz for 802.11 ac80; |
| | Modulation Type: | BT(1Mbps)/BLE: GFSK BT EDR(2Mbps): $\pi/4$ -DQPSK BT EDR(3Mbps): 8-DPSK IEEE 802.11b : DSSS (CCK, DQPSK, DBPSK) IEEE 802.11g/n (HT20) : OFDM (64QAM, 16QAM, QPSK, BPSK) OFDM with BPSK/QPSK/16QAM/64QAM/256QAM for 802.11a/n/ac; |
| Power Source | DC 19V from Adapter. | |
| Adapter | Model: ADP-120ZB BB Input: AC 100-240V, 50/60Hz, 2A Output: DC 19V, 6.32A | |
| Battery | N/A | |
| HW Version | Y3_T826_MAIN_V2.0 | |
| SW Version | VEN20170824V001 | |

2.1.1 DESCRIPTION OF TEST MODES

To investigate the maximum EMI emission characteristics generates from EUT, the test system was pre-scanning tested base on the consideration of following EUT operation mode or test configuration mode which possible have effect on EMI emission level. Each of these EUT operation mode(s) or test configuration mode(s) mentioned above was evaluated respectively.

| Pretest Mode | Description |
|--------------|-------------|
| Mode 1 | HDMI |
| Mode 2 | USB |
| Mode 3 | LAN |
| Mode 4 | BT |

| For Conducted Test | |
|--------------------|-------------|
| Final Test Mode | Description |
| Mode 1 | HDMI |
| Mode 2 | USB |
| Mode 3 | LAN |
| Mode 4 | BT |

| For Radiated Test | |
|-------------------|-------------|
| Final Test Mode | Description |
| Mode 1 | HDMI |
| Mode 2 | USB |
| Mode 3 | LAN |
| Mode 4 | BT |

Note: Final Test Mode: Through Pre-scan, find the mode 1 is the worst case.
Only the worst case mode is recorded in the report.

2.1.2 DESCRIPTION OF TEST SETUP

CE

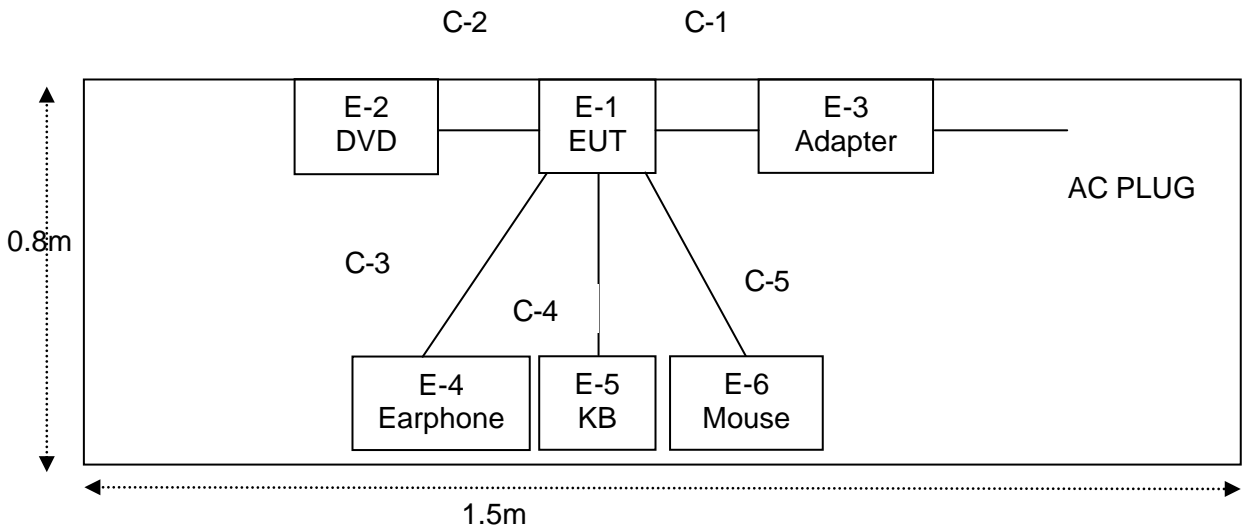

RE

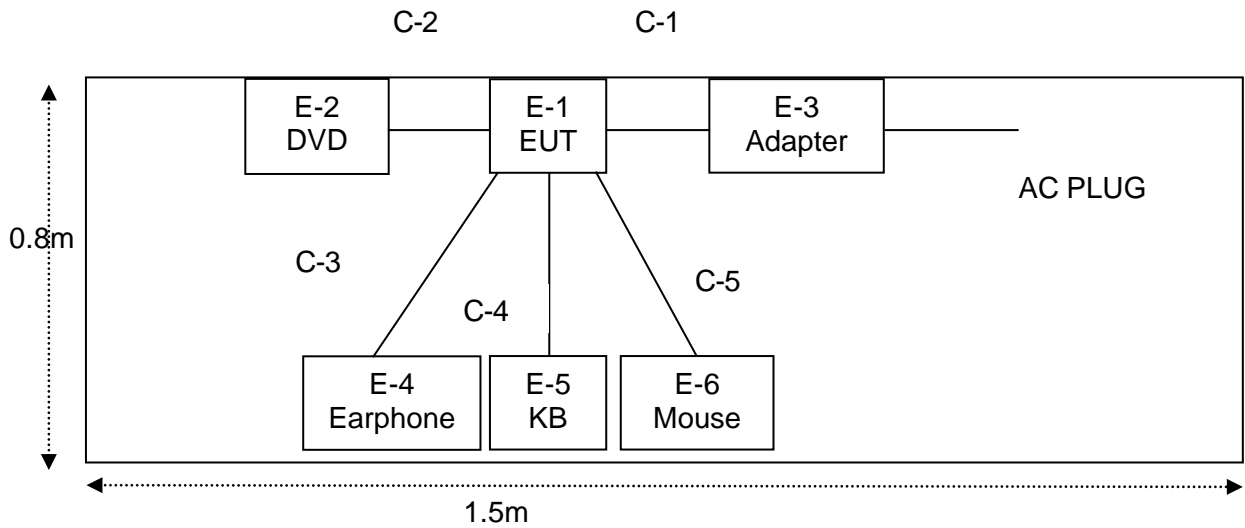

2.2 DESCRIPTION TEST PERIPHERAL AND EUT PERIPHERAL

The EUT has been tested as an independent unit together with other necessary accessories or support units. The following support units or accessories were used to form a representative test configuration during the tests.

| Item | Equipment | Brand | Model/Type No. | Series No. | Note |
|------|------------------------------|-------|----------------|--------------------|-------------|
| E-1 | PIQS Virtual Touch Projector | PIQS | V | N/A | EUT |
| E-2 | DVD | N/A | N/A | N/A | |
| E-3 | Adapter | N/A | ADP-120ZP BB | N/A | EUT |
| E-4 | Earphone | N/A | N/A | N/A | |
| E-5 | KB | Logi | Y-U0011 | 820-003405 SY109UK | Peripherals |
| E-6 | Mouse | HP | MS-SBF96 | 417441-002REV.OC | Peripherals |
| | | | | | |
| | | | | | |
| | | | | | |
| | | | | | |

| Item | Cable Type | Shielded Type | Ferrite Core | Length | Note |
|------|----------------|---------------|--------------|--------|------|
| C-1 | Power Cable | NO | NO | 1.2m | |
| C-2 | HDMI Cable | NO | NO | 1.0m | |
| C-3 | Earphone Cable | NO | NO | 0.8m | |
| C-4 | KB Cable | NO | NO | 1.2m | |
| C-5 | Mouse Cable | NO | NO | 1.2m | |
| | | | | | |
| | | | | | |
| | | | | | |

Note:

- (1) The support equipment was authorized by Declaration of Confirmation.
- (2) For detachable type I/O cable should be specified the length in cm in 『Length』 column.
- (3) “YES” means “shielded” “with core”; “NO” means “unshielded” “without core”.

2.3 MEASUREMENT INSTRUMENTS LIST

Radiation Test equipment

| Item | Kind of Equipment | Manufacturer | Type No. | Serial No. | Last calibration | Calibrated until | Calibration period |
|------|---------------------------|--------------|-------------|----------------|------------------|------------------|--------------------|
| 1 | Spectrum Analyzer | Agilent | E4407B | MY45108040 | 2017.06.06 | 2018.06.05 | 1 year |
| 2 | Test Receiver | R&S | ESPI | 101318 | 2017.06.06 | 2018.06.05 | 1 year |
| 3 | Bilog Antenna | TESEQ | CBL6111D | 31216 | 2017.04.09 | 2018.04.08 | 1 year |
| 4 | 50Ω Coaxial Switch | Anritsu | MP59B | 6200264416 | 2017.06.06 | 2018.06.05 | 1 year |
| 5 | Spectrum Analyzer | ADVANTEST | R3132 | 150900201 | 2017.06.06 | 2018.06.05 | 1 year |
| 6 | Horn Antenna | EM | EM-AH-10180 | 2011071402 | 2017.04.09 | 2018.04.08 | 1 year |
| 7 | Horn Ant | Schwarzbeck | BBHA 9170 | 9170-181 | 2017.07.06 | 2018.07.05 | 1 year |
| 8 | Amplifier | EMC | EMC051835SE | 980246 | 2017.08.09 | 2018.08.08 | 1 year |
| 9 | Loop Antenna | ARA | PLA-1030/B | 1029 | 2017.06.06 | 2018.06.05 | 1 year |
| 10 | Power Meter | DARE | RPR3006W | 15I00041S NO84 | 2017.08.09 | 2018.08.08 | 1 year |
| 11 | Power Sensor | R&S | URV5-Z4 | 0395.1619.05 | 2017.07.06 | 2018.07.05 | 1 year |
| 12 | Test Cable (30MHz-1GHz) | N/A | R-02 | N/A | 2017.04.21 | 2020.04.20 | 3 year |
| 13 | High Test Cable(1G-40GHz) | N/A | R-03 | N/A | 2017.04.21 | 2020.04.20 | 3 year |
| 14 | High Test Cable(1G-40GHz) | N/A | R-04 | N/A | 2017.04.21 | 2020.04.20 | 3 year |

Conduction Test equipment

| Item | Kind of Equipment | Manufacturer | Type No. | Serial No. | Last calibration | Calibrated until | Calibration period |
|------|-------------------------|--------------|-----------|------------|------------------|------------------|--------------------|
| 1 | Test Receiver | R&S | ESCI | 101160 | 2017.06.06 | 2018.06.05 | 1 year |
| 2 | LISN | R&S | ENV216 | 101313 | 2017.04.19 | 2018.04.18 | 1 year |
| 3 | LISN | SCHWARZBECK | NNLK 8129 | 8129245 | 2017.06.06 | 2018.06.05 | 1 year |
| 4 | 50Ω Coaxial Switch | ANRITSU CORP | MP59B | 6200983704 | 2017.06.06 | 2018.06.05 | 1 year |
| 5 | Test Cable (9KHz-30MHz) | N/A | C01 | N/A | 2017.04.21 | 2020.04.20 | 3 year |
| 6 | Test Cable (9KHz-30MHz) | N/A | C02 | N/A | 2017.04.21 | 2020.04.20 | 3 year |
| 7 | Test Cable (9KHz-30MHz) | N/A | C03 | N/A | 2017.04.21 | 2020.04.20 | 3 year |

3. EMC EMISSION TEST

3.1 CONDUCTED EMISSION MEASUREMENT

3.1.1 POWER LINE CONDUCTED EMISSION (Frequency Range 150KHz-30MHz)

| FREQUENCY (MHz) | Class A (dBuV) | | Class B (dBuV) | |
|-----------------|----------------|---------|----------------|-----------|
| | Quasi-peak | Average | Quasi-peak | Average |
| 0.15 -0.5 | 79.00 | 66.00 | 66 - 56 * | 56 - 46 * |
| 0.50 -5.0 | 73.00 | 60.00 | 56.00 | 46.00 |
| 5.0 -30.0 | 73.00 | 60.00 | 60.00 | 50.00 |

Note:

- (1) The tighter limit applies at the band edges.
- (2) The limit of " * " marked band means the limitation decreases linearly with the logarithm of the frequency in the range.

The following table is the setting of the receiver

| Receiver Parameters | Setting |
|---------------------|----------|
| Attenuation | 10 dB |
| Start Frequency | 0.15 MHz |
| Stop Frequency | 30 MHz |
| IF Bandwidth | 9 kHz |

3.1.2 TEST PROCEDURE

- a. The EUT was placed 0.8 meters from the horizontal ground plane with EUT being connected to the power mains through a line impedance stabilization network (LISN). All other support equipments powered from additional LISN(s). The LISN provide 50 Ohm/ 50uH of coupling impedance for the measuring instrument.
- b. Interconnecting cables that hang closer than 40 cm to the ground plane shall be folded back and forth in the center forming a bundle 30 to 40 cm long.
- c. I/O cables that are not connected to a peripheral shall be bundled in the center. The end of the cable may be terminated, if required, using the correct terminating impedance. The overall length shall not exceed 1 m.
- d. LISN at least 80 cm from nearest part of EUT chassis.
- e. For the actual test configuration, please refer to the related Item –EUT Test Photos.

3.1.3 TEST SETUP

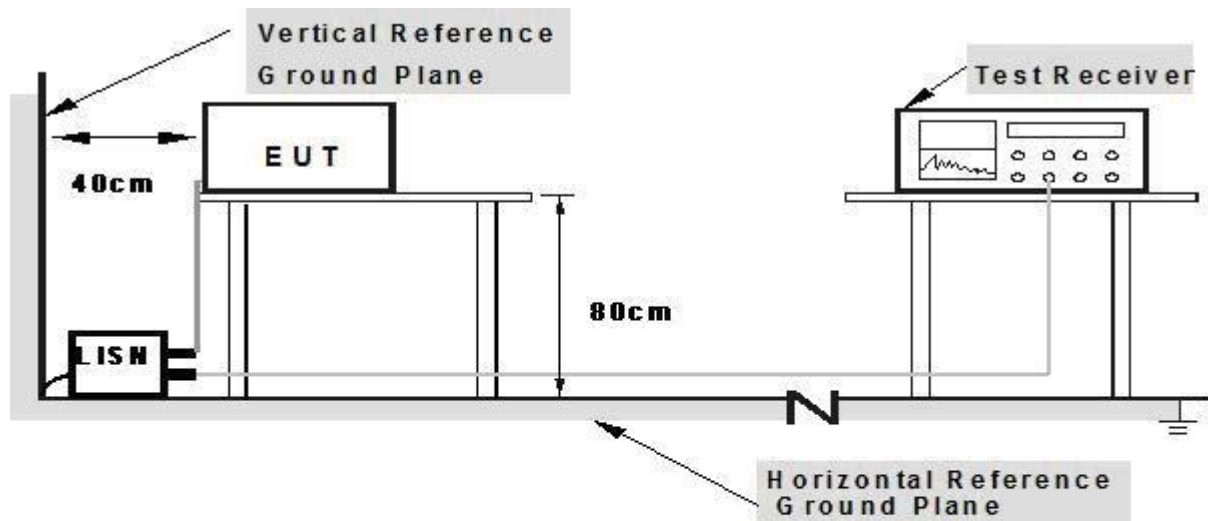

- Note: 1. Support units were connected to second LISN.**
2. Both of LISNs (AMN) are 80 cm from EUT and at least 80 cm from other units and other metal planes

3.1.4 EUT OPERATING CONDITIONS

The EUT tested system was configured as the statements of 2.3 Unless otherwise a special operating condition is specified in the follows during the testing.

3.1.5 TEST RESULTS

| | | | |
|---------------|----------------------------------|--------------------|------------|
| EUT: | PIQS Virtual Touch Projector | Model Name. : | V |
| Temperature: | 26 °C | Relative Humidity: | 54% |
| Pressure: | 1010hPa | Test Date: | 2017-08-26 |
| Test Mode: | Mode 1 | Phase : | L |
| Test Voltage: | DC 19V from Adapter AC 120V/60Hz | | |

| Frequency (MHz) | Reading Level (dB μ V) | Correct Factor (dB) | Measure-ment (dB μ V) | Limits (dB μ V) | Margin (dB) | Remark |
|-----------------|----------------------------|---------------------|---------------------------|---------------------|-------------|--------|
| 0.158 | 43.78 | 9.82 | 53.6 | 65.56 | -11.96 | QP |
| 0.158 | 19.87 | 9.82 | 29.69 | 55.56 | -25.87 | AVG |
| 0.2779 | 45.31 | 9.82 | 55.13 | 60.88 | -5.75 | QP |
| 0.2779 | 28.4 | 9.82 | 38.22 | 50.88 | -12.66 | AVG |
| 0.442 | 37.73 | 9.83 | 47.56 | 57.02 | -9.46 | QP |
| 0.442 | 26.19 | 9.83 | 36.02 | 47.02 | -11 | AVG |
| 0.582 | 32.99 | 9.83 | 42.82 | 56 | -13.18 | QP |
| 0.582 | 22.42 | 9.83 | 32.25 | 46 | -13.75 | AVG |
| 9.622 | 40.98 | 9.98 | 50.96 | 60 | -9.04 | QP |
| 9.622 | 33.22 | 9.98 | 43.2 | 50 | -6.8 | AVG |
| 12.8299 | 35.75 | 10.11 | 45.86 | 60 | -14.14 | QP |
| 12.8299 | 25.33 | 10.11 | 35.44 | 50 | -14.56 | AVG |

Remark:

- All readings are Quasi-Peak and Average values.
- Factor = Insertion Loss + Cable Loss.

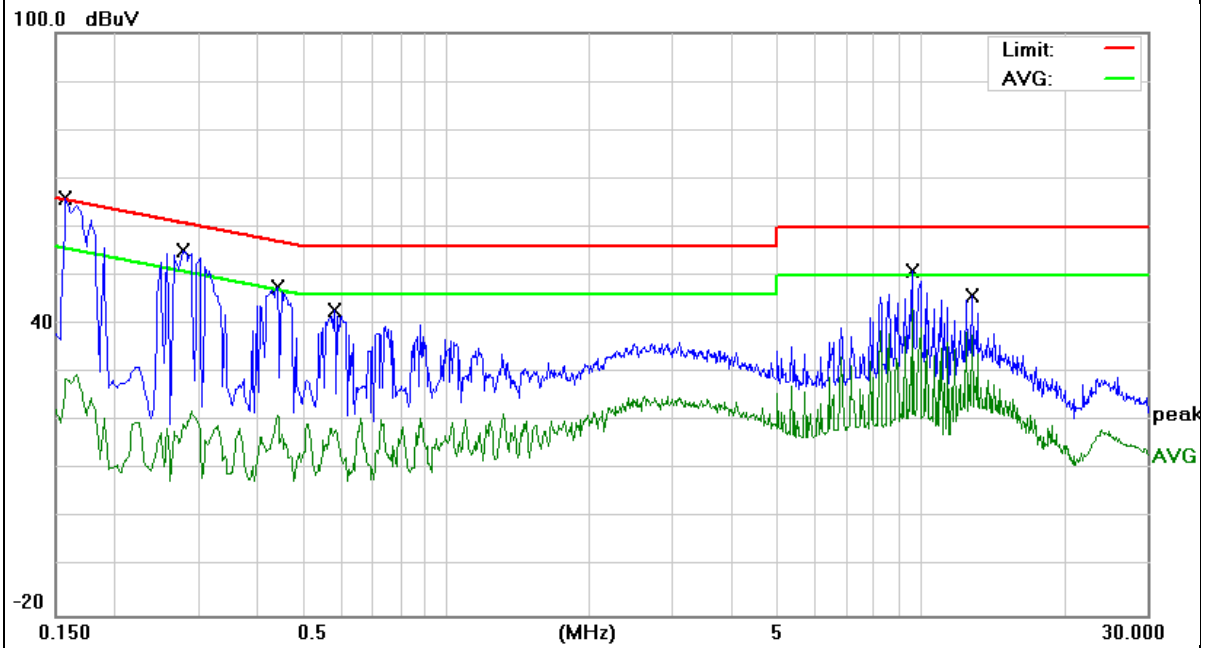

| | | | |
|---------------|----------------------------------|--------------------|------------|
| EUT: | PIQS Virtual Touch Projector | Model Name. : | V |
| Temperature: | 26 °C | Relative Humidity: | 54% |
| Pressure: | 1010hPa | Test Date: | 2017-08-26 |
| Test Mode: | Mode 1 | Phase : | N |
| Test Voltage: | DC 19V from Adapter AC 120V/60Hz | | |

| Frequency (MHz) | Reading Level (dB μ V) | Correct Factor (dB) | Measure-ment (dB μ V) | Limits (dB μ V) | Margin (dB) | Remark |
|-----------------|----------------------------|---------------------|---------------------------|---------------------|-------------|--------|
| 0.158 | 44.48 | 9.92 | 54.4 | 65.56 | -11.16 | QP |
| 0.158 | 18.27 | 9.92 | 28.19 | 55.56 | -27.37 | AVG |
| 0.17 | 48.33 | 9.92 | 58.25 | 64.96 | -6.71 | QP |
| 0.17 | 40.1 | 9.92 | 50.02 | 54.96 | -4.94 | AVG |
| 0.258 | 44.86 | 9.92 | 54.78 | 61.49 | -6.71 | QP |
| 0.258 | 33.33 | 9.92 | 43.25 | 51.49 | -8.24 | AVG |
| 0.3019 | 43.24 | 9.92 | 53.16 | 60.19 | -7.03 | QP |
| 0.3019 | 32.33 | 9.92 | 42.25 | 50.19 | -7.94 | AVG |
| 0.4099 | 37.29 | 9.93 | 47.22 | 57.65 | -10.43 | QP |
| 0.4099 | 29.09 | 9.93 | 39.02 | 47.65 | -8.63 | AVG |
| 9.622 | 40.31 | 10.08 | 50.39 | 60 | -9.61 | QP |
| 9.622 | 33.23 | 10.08 | 43.31 | 50 | -6.69 | AVG |

Remark:

1. All readings are Quasi-Peak and Average values.
2. Factor = Insertion Loss + Cable Loss.

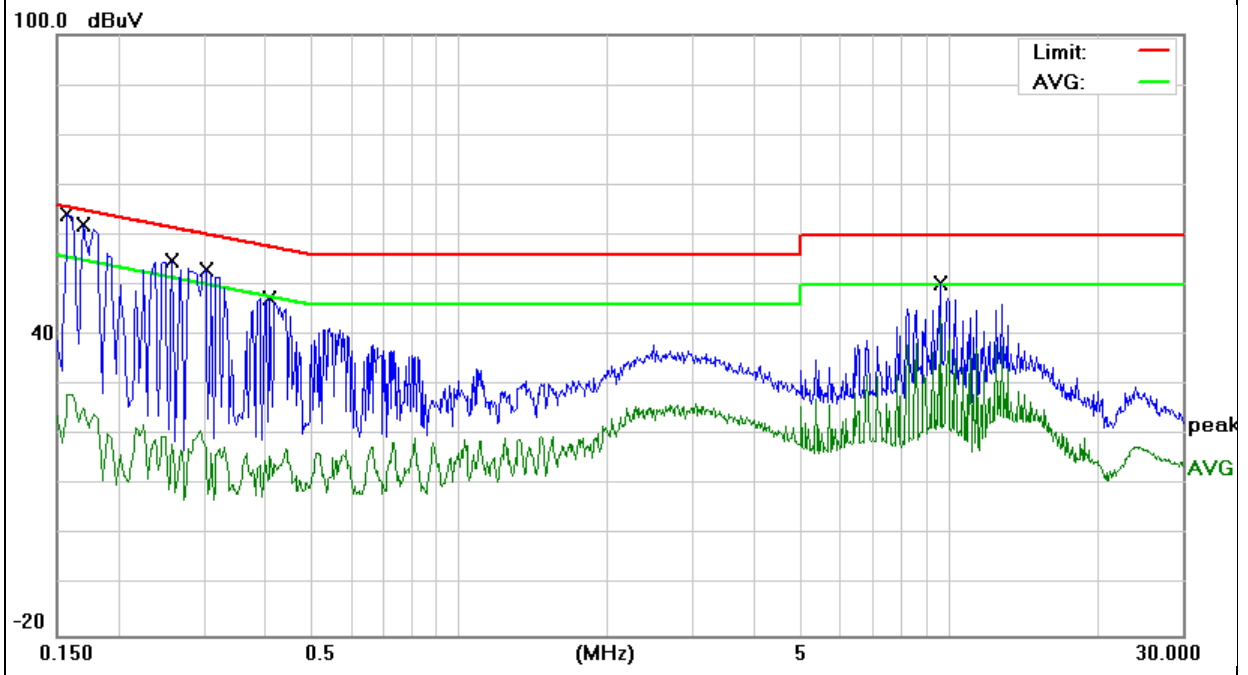

| | | | |
|---------------|---------------------------------|--------------------|------------|
| EUT: | PIQS Virtual Touch Projector | Model Name. : | V |
| Temperature: | 26 °C | Relative Humidity: | 54% |
| Pressure: | 1010hPa | Test Date: | 2017-08-26 |
| Test Mode: | Mode 1 | Phase : | L |
| Test Voltage: | DC 19V from Adapter AC240V/60Hz | | |

| Frequency (MHz) | Reading Level (dBμV) | Correct Factor (dB) | Measure-ment (dBμV) | Limits (dBμV) | Margin (dB) | Remark |
|-----------------|----------------------|---------------------|---------------------|---------------|-------------|--------|
| 0.1539 | 38.78 | 9.82 | 48.6 | 65.78 | -17.18 | QP |
| 0.1539 | 21.01 | 9.82 | 30.83 | 55.78 | -24.95 | AVG |
| 0.186 | 48.09 | 9.82 | 57.91 | 64.21 | -6.3 | QP |
| 0.186 | 14.57 | 9.82 | 24.39 | 54.21 | -29.82 | AVG |
| 0.222 | 42.52 | 9.82 | 52.34 | 62.74 | -10.4 | QP |
| 0.222 | 32.43 | 9.82 | 42.25 | 52.74 | -10.49 | AVG |
| 0.266 | 40.89 | 9.82 | 50.71 | 61.24 | -10.53 | QP |
| 0.266 | 30.2 | 9.82 | 40.02 | 51.24 | -11.22 | AVG |
| 0.302 | 39.49 | 9.82 | 49.31 | 60.19 | -10.88 | QP |
| 0.302 | 31.5 | 9.82 | 41.32 | 50.19 | -8.87 | AVG |
| 3.946 | 33.86 | 10.05 | 43.91 | 56 | -12.09 | QP |
| 3.946 | 26.22 | 10.05 | 36.27 | 46 | -9.73 | AVG |

Remark:

- All readings are Quasi-Peak and Average values.
- Factor = Insertion Loss + Cable Loss.

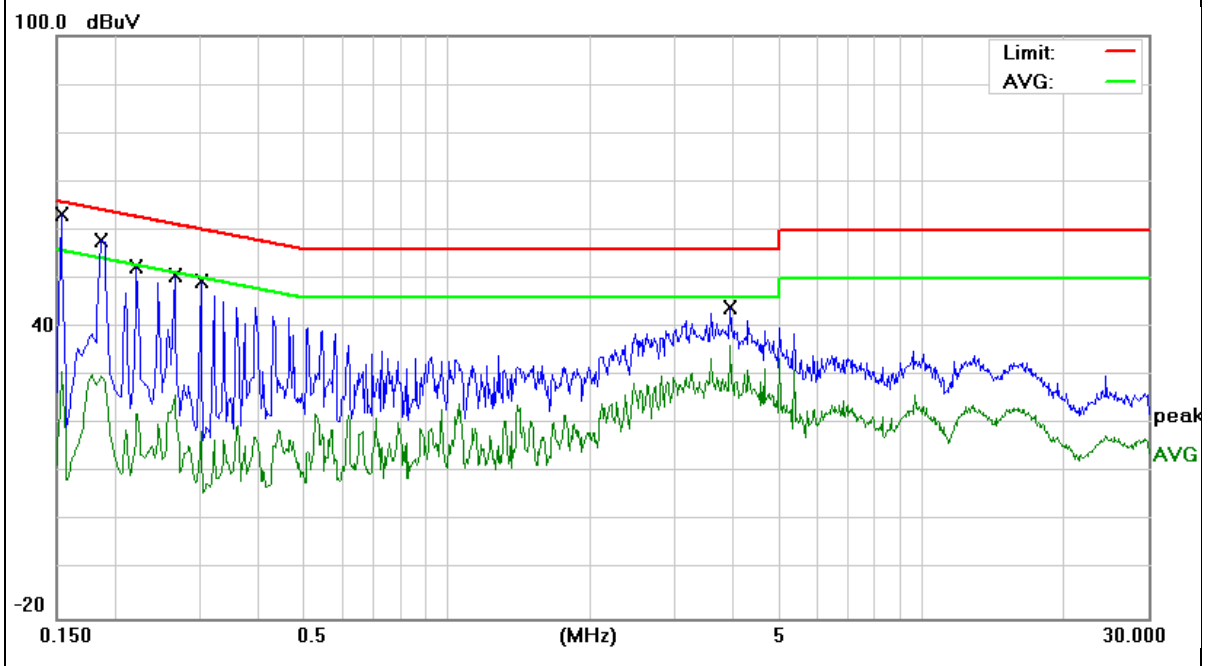

| | | | |
|---------------|---------------------------------|--------------------|------------|
| EUT: | PIQS Virtual Touch Projector | Model Name. : | V |
| Temperature: | 26 °C | Relative Humidity: | 54% |
| Pressure: | 1010hPa | Test Date: | 2017-08-26 |
| Test Mode: | Mode 1 | Phase : | N |
| Test Voltage: | DC 19V from Adapter AC240V/60Hz | | |

| Frequency (MHz) | Reading Level (dBμV) | Correct Factor (dB) | Measure-ment (dBμV) | Limits (dBμV) | Margin (dB) | Remark |
|-----------------|----------------------|---------------------|---------------------|---------------|-------------|--------|
| 0.166 | 49.74 | 9.92 | 59.66 | 65.15 | -5.49 | QP |
| 0.166 | 19.19 | 9.92 | 29.11 | 55.15 | -26.04 | AVG |
| 0.186 | 44.82 | 9.92 | 54.74 | 64.21 | -9.47 | QP |
| 0.186 | 21.33 | 9.92 | 31.25 | 54.21 | -22.96 | AVG |
| 0.202 | 47.16 | 9.92 | 57.08 | 63.52 | -6.44 | QP |
| 0.202 | 17.16 | 9.92 | 27.08 | 53.52 | -26.44 | AVG |
| 0.222 | 45.78 | 9.92 | 55.7 | 62.74 | -7.04 | QP |
| 0.222 | 30.33 | 9.92 | 40.25 | 52.74 | -12.49 | AVG |
| 0.294 | 41.54 | 9.92 | 51.46 | 60.41 | -8.95 | QP |
| 0.294 | 27.06 | 9.92 | 36.98 | 50.41 | -13.43 | AVG |
| 3.946 | 32.98 | 9.95 | 42.93 | 56 | -13.07 | QP |
| 3.946 | 25.55 | 9.95 | 35.5 | 46 | -10.5 | AVG |

Remark:

1. All readings are Quasi-Peak and Average values.
2. Factor = Insertion Loss + Cable Loss.

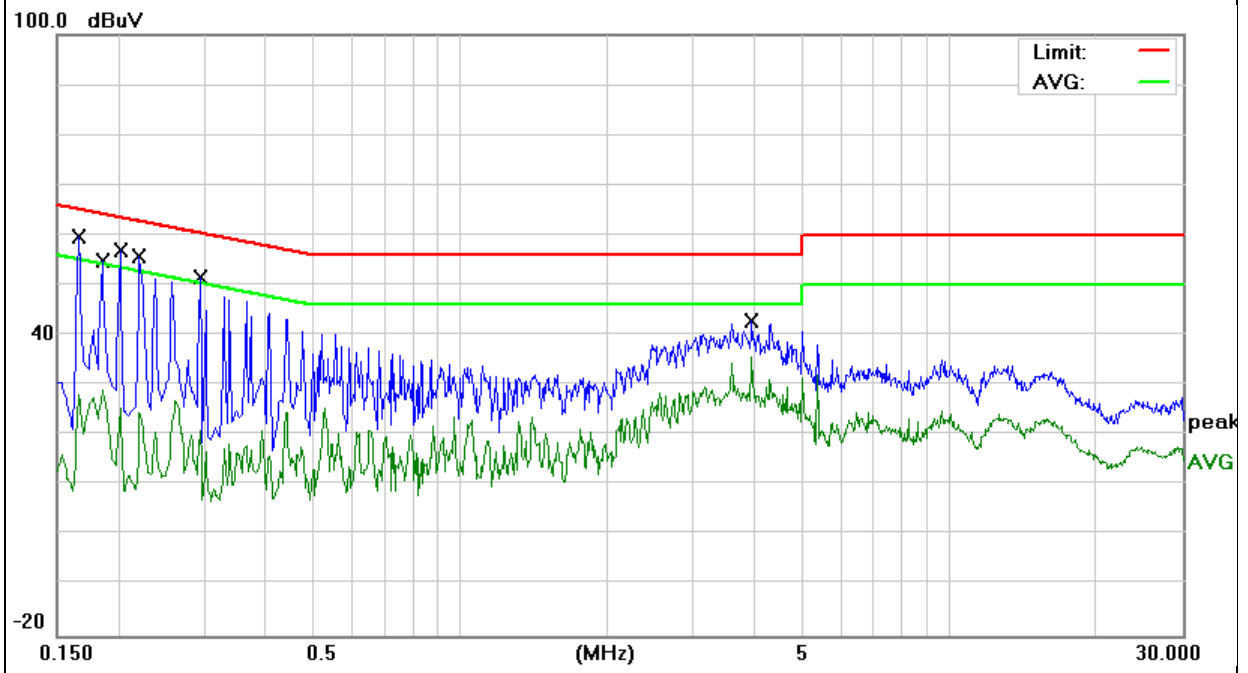

3.2 RADIATED EMISSION MEASUREMENT

3.2.1 LIMITS OF RADIATED EMISSION MEASUREMENT

| FREQUENCY (MHz) | Class A (at 10m) | Class B (at 3m) |
|-----------------|------------------|-----------------|
| | dBuV/m | dBuV/m |
| 30 ~ 88 | 39.0 | 40.0 |
| 88 ~ 216 | 43.5 | 43.5 |
| 216 ~ 960 | 46.5 | 46.0 |
| Above 960 | 49.5 | 54.0 |

Notes:

- (1) The limit for radiated test was performed according to as following:
FCC PART 15B /ICES-003.
- (2) The tighter limit applies at the band edges.
- (3) Emission level (dBuV/m)=20log Emission level (uV/m).

3.2.2 TEST PROCEDURE

Test Arrangement for Radiated Emissions up to 1 GHz

- a. The EUT was placed on the top of a rotating table 0.8 meters above the ground at an accredited test facility. The table was rotated 360 degrees to determine the position of the highest radiation.
- b. The EUT was set 3 meters away from the interference-receiving antenna, which was mounted on the top of a variable-height antenna tower.
- c. The antenna is a broadband antenna, and its height is varied from one meter to four meters above the ground to determine the maximum value of the field strength. Both horizontal and vertical polarizations of the antenna are set to make the measurement.
- d. For each suspected emission, the EUT was arranged to its worst case and then the antenna was tuned to heights from 1 meter to 4 meters and the rotatable table was turned from 0 degrees to 360 degrees to find the maximum reading.

Note: The resolution bandwidth and video bandwidth of test receiver/spectrum analyzer is 120kHz for quasi-peak detection (QP) at frequency below 1GHz.

Test Arrangement for Radiated Emissions above 1 GHz.

- a. The EUT was placed on the top of a rotating table 0.8 meters above the ground at an accredited chamber room. The table was rotated 360 degrees to determine the position of the highest radiation.
- b. The EUT was set 3 meters away from the interference-receiving antenna, which was mounted on the top of a variable-height antenna tower.
- c. The height of antenna can be varied from one meter to four meters, the height of adjustment depends on the EUT height and the antenna 3dB beamwidth both, to detect the maximum value of the field strength.Both horizontal and vertical polarizations of the antenna are set to make the measurement.
- d. For each suspected emission, the EUT was arranged to its worst case and then the antenna was tuned to heights and the rotatable table was turned from 0 degrees to 360 degrees to find the maximum reading.

Note: For the hand-held device, the EUT should be measured for all 3 axes and only the worst case is recorded in the report
 During the radiated emission test, the Spectrum Analyzer was set with the following configurations:

| Frequency Band (MHz) | Function | Resolution bandwidth | Video Bandwidth |
|----------------------|----------|----------------------|-----------------|
| 30 to 1000 | QP | 120 kHz | 300 kHz |
| Above 1000 | Peak | 1 MHz | 1 MHz |
| | Avg | 1 MHz | 10 Hz |

3.2.3 TEST SETUP

For Radiated Emission 30~1000MHz

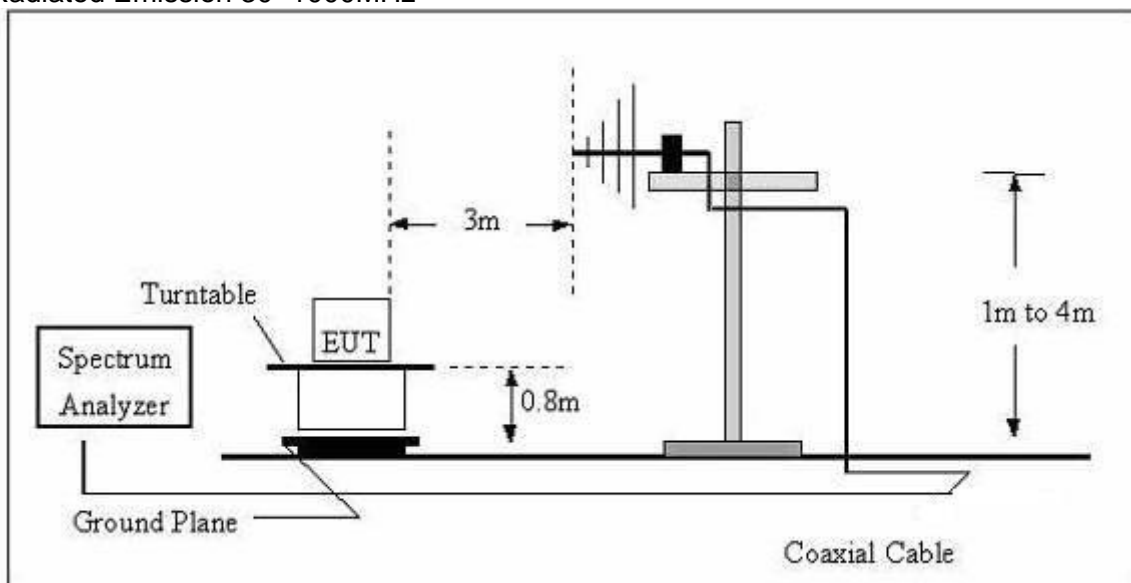

(B) Radiated Emission Test Set-Up Frequency Above 1GHz

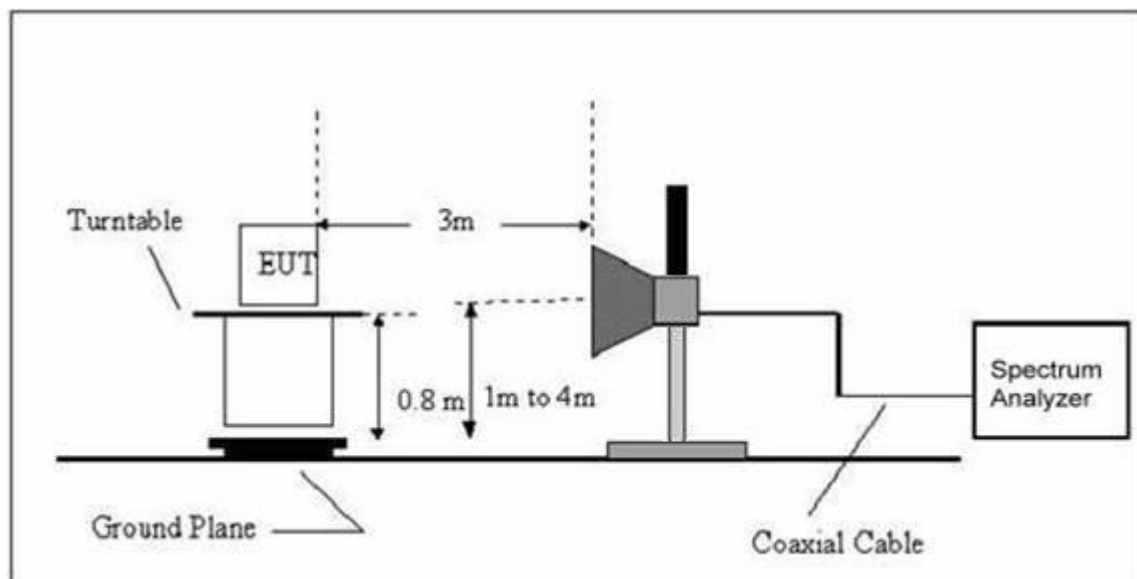

3.2.4 TEST RESULTS

TEST RESULTS (30~1000 MHz)

| | | | |
|--------------|----------------------------------|--------------------|------------|
| EUT: | PIQS Virtual Touch Projector | Model Name: | V |
| Temperature: | 24 °C | Relative Humidity: | 54% |
| Pressure: | 1010 hPa | Test Date : | 2017-08-26 |
| Test Mode : | Mode 1 | Polarization : | Horizontal |
| Test Power : | DC 19V from Adapter AC 120V/60Hz | | |

| Polar (H/V) | Frequency | Meter Reading | Factor | Emission Level | Limits | Margin | Remark |
|-------------|-----------|---------------|--------|----------------|----------|--------|--------|
| | (MHz) | (dBuV) | (dB) | (dBuV/m) | (dBuV/m) | (dB) | |
| H | 75.9772 | 24.44 | 11.56 | 36 | 40 | -4 | QP |
| H | 140.8351 | 23.15 | 11.35 | 34.5 | 43.5 | -9 | QP |
| H | 240.8304 | 28.73 | 11.97 | 40.7 | 46 | -5.3 | QP |
| H | 292.0582 | 26.94 | 14.26 | 41.2 | 46 | -4.8 | QP |
| H | 352.9433 | 26.91 | 14.39 | 41.3 | 46 | -4.7 | QP |
| H | 480.5276 | 21.63 | 16.92 | 38.55 | 46 | -7.45 | QP |

Remark:
Factor = Antenna Factor + Cable Loss - Amplifier.

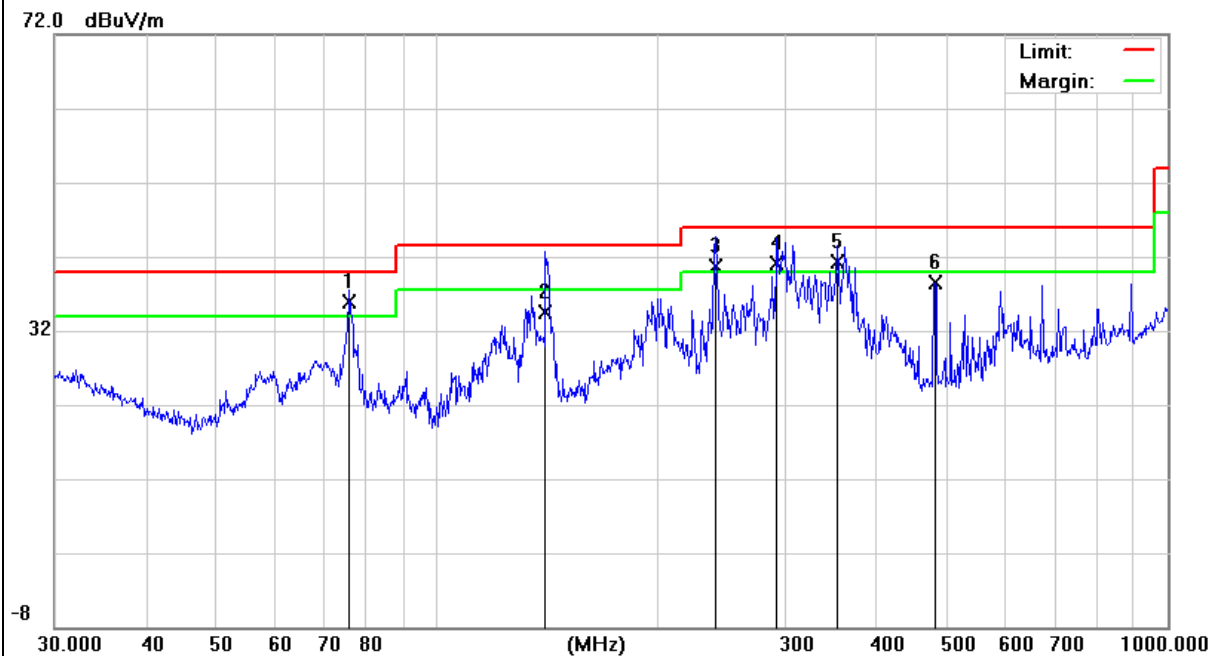

| | | | |
|--------------|----------------------------------|--------------------|------------|
| EUT: | PIQS Virtual Touch Projector | Model Name : | V |
| Temperature: | 24 °C | Relative Humidity: | 54% |
| Pressure: | 1010 hPa | Test Date : | 2017-08-26 |
| Test Mode : | Mode 1 | Polarization : | Vertical |
| Test Power : | DC 19V from Adapter AC 120V/60Hz | | |

| Polar (H/V) | Frequency | Meter Reading | Factor | Emission Level | Limits | Margin | Remark |
|-------------|-----------|---------------|--------|----------------|----------|--------|--------|
| | (MHz) | (dBuV) | (dB) | (dBuV/m) | (dBuV/m) | (dB) | |
| V | 75.9773 | 20.14 | 11.56 | 31.7 | 40 | -8.3 | QP |
| V | 124.1329 | 29.14 | 10.58 | 39.72 | 43.5 | -3.78 | QP |
| V | 141.3298 | 23.75 | 11.35 | 35.1 | 43.5 | -8.4 | QP |
| V | 240.8304 | 29.75 | 11.97 | 41.72 | 46 | -4.28 | QP |
| V | 478.8456 | 22.56 | 16.87 | 39.43 | 46 | -6.57 | QP |
| V | 672.8444 | 20.76 | 21.01 | 41.77 | 46 | -4.23 | QP |

Remark:

Factor = Antenna Factor + Cable Loss - Amplifier.

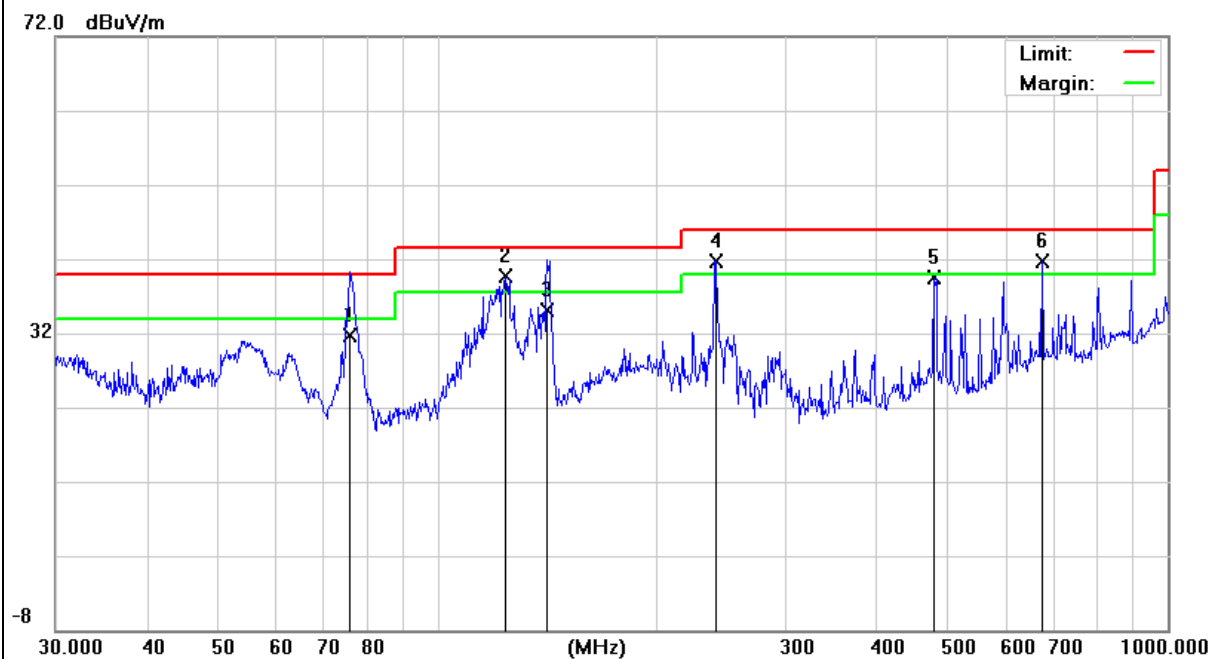

3.2.5 TEST RESULTS(1000~6000MHz)

| | | | |
|--------------|----------------------------------|--------------------|------------|
| EUT: | PIQS Virtual Touch Projector | Model Name : | V |
| Temperature: | 24 °C | Relative Humidity: | 54% |
| Pressure: | 1010 hPa | Test Date : | 2017-08-26 |
| Test Mode : | Mode 1 | | |
| Test Power : | DC 19V from Adapter AC 120V/60Hz | | |

All the modulation modes have been tested, and the worst result was report as below:

| Polar (H/V) | Frequency | Reading | Correct | Result | Limit | Over Limit | Remark |
|-------------|-----------|----------|---------|----------|----------|------------|--------|
| | (MHz) | (dBuV/m) | dB/m | (dBuV/m) | (dBuV/m) | (dB) | |
| V | 1780.593 | 45.27 | -8.37 | 36.9 | 74 | -37.1 | Pk |
| V | 1780.593 | 30.73 | -8.37 | 22.36 | 54 | -31.64 | AV |
| V | 2288.263 | 40.18 | -6.29 | 33.89 | 74 | -40.11 | Pk |
| V | 2288.263 | 31.41 | -6.29 | 25.12 | 54 | -28.88 | AV |
| V | 2821.952 | 39.27 | -5.1 | 34.17 | 74 | -39.83 | Pk |
| V | 2821.952 | 26.12 | -5.1 | 21.02 | 54 | -32.98 | AV |
| V | 3672.297 | 38.66 | -2.42 | 36.24 | 74 | -37.76 | Pk |
| V | 3672.297 | 25.64 | -2.42 | 23.22 | 54 | -30.78 | AV |
| V | 3994.946 | 37.84 | -0.48 | 37.36 | 74 | -36.64 | Pk |
| V | 3994.946 | 24.73 | -0.48 | 24.25 | 54 | -29.75 | AV |
| V | 4926.683 | 36.81 | 4.83 | 41.64 | 74 | -32.36 | Pk |
| V | 4926.683 | 18.53 | 4.83 | 23.36 | 54 | -30.64 | AV |
| H | 1515.413 | 51.29 | -8.44 | 42.85 | 74 | -31.15 | Pk |
| H | 1515.413 | 31.76 | -8.44 | 23.32 | 54 | -30.68 | AV |
| H | 1780.593 | 45.16 | -8.37 | 36.79 | 74 | -37.21 | Pk |
| H | 1780.593 | 33.39 | -8.37 | 25.02 | 54 | -28.98 | AV |
| H | 1882.293 | 44.15 | -7.99 | 36.16 | 74 | -37.84 | Pk |
| H | 1882.293 | 29.43 | -7.99 | 21.44 | 54 | -32.56 | AV |
| H | 2207.714 | 40.38 | -5.86 | 34.52 | 74 | -39.48 | Pk |
| H | 2207.714 | 29.12 | -5.86 | 23.26 | 54 | -30.74 | AV |
| H | 3895.981 | 39.4 | -0.65 | 38.75 | 74 | -35.25 | Pk |
| H | 3895.981 | 21.89 | -0.65 | 21.24 | 54 | -32.76 | AV |
| H | 4753.26 | 37.91 | 4.45 | 42.36 | 74 | -31.64 | Pk |
| H | 4753.26 | 18.2 | 4.45 | 22.65 | 54 | -31.35 | AV |

Remark:

Absolute Level= ReadingLevel+ Factor, Margin= Absolute Level - Limit

Note: Only the worst results data points are reported in the report.