

# RADIO TEST REPORT

## FCC ID: 2ALH2-PFAM300

**Product :** Remote Controller

**Trade Mark :** PIQS

**Model Name :** M3

**Serial Model :** N/A

**Report No. :** NTEK-2017NT08266062F

### Prepared for

PIQS Technology(Shenzhen) Limited  
West, 6F Buiding 1, No.35 CuiJing Road, Pingshan New District,  
Shenzhen City, Guangdong Province, P.R.China

### Prepared by

Shenzhen NTEK Testing Technology Co., Ltd.  
1/F, Building E, Fenda Science Park, Sanwei Community, Xixiang Street  
Bao'an District, Shenzhen 518126 P.R. China  
Tel.: +86-755-6115 9388 Fax.: +86-755-6115 6599  
Website:<http://www.ntek.org.cn>

### TEST RESULT CERTIFICATION

**Applicant's name** ..... : PIQS Technology(Shenzhen) Limited  
 Address ..... : West, 6F Buiding 1, No.35 CuiJing Road, Pingshan New District,  
 Shenzhen City, Guangdong Province, P.R.China  
**Manufacturer's Name** ..... : PIQS Technology(Shenzhen) Limited  
 Address ..... : West, 6F Buiding 1, No.35 CuiJing Road, Pingshan New District,  
 Shenzhen City, Guangdong Province, P.R.China

**Product description**

Product name ..... : Remote Controller  
 Model and/or type reference : M3  
 Serial Model : N/A  
 Rating(s) ..... : TX: DC 3.7V

**Standards** ..... : FCC Part15.249: 2017

Test procedure ..... ANSI C63.10-2013

This device described above has been tested by NTEK, and the test results show that the equipment under test (EUT) is in compliance with the FCC requirements. And it is applicable only to the tested sample identified in the report.

This report shall not be reproduced except in full, without the written approval of NTEK, this document may be altered or revised by NTEK, personnel only, and shall be noted in the revision of the document.

**Date of Test** ..... :  
 Date (s) of performance of tests ..... : 26 Oct. 2017 ~10 Nov. 2017  
 Date of Issue..... : 10 Nov. 2017  
 Test Result..... : **Pass**

**Testing Engineer** : Allen Liu  
 (Allen Liu)

**Technical Manager** : Jason Chen  
 (Jason Chen)

**Authorized Signatory** : Sam Chen  
 (Sam Chen)

<b>Table of Contents</b>	<b>Page</b>
<b>1 . SUMMARY OF TEST RESULTS</b>	<b>4</b>
1.1 TEST FACILITY	5
1.2 MEASUREMENT UNCERTAINTY	5
<b>2 . GENERAL INFORMATION</b>	<b>6</b>
2.1 GENERAL DESCRIPTION OF EUT	6
2.2 DESCRIPTION OF TEST MODES	8
2.3 BLOCK DIGRAM SHOWING THE CONFIGURATION OF SYSTEM TESTED	9
2.4 DESCRIPTION OF SUPPORT UNITS(CONDUCTED MODE)	10
2.5 EQUIPMENTS LIST FOR ALL TEST ITEMS	11
<b>3 . ANTENNA REQUIREMENT</b>	<b>13</b>
3.1 STANDARD REQUIREMENT	13
3.2 EUT ANTENNA	13
3.3 CONDUCTED EMISSION MEASUREMENT	14
3.3.1 POWER LINE CONDUCTED EMISSION LIMITS	14
3.3.2 TEST PROCEDURE	15
3.3.3 DEVIATION FROM TEST STANDARD	15
3.3.4 TEST SETUP	15
3.2.5 TEST RESULT	16
3.4 RADIATED EMISSION MEASUREMENT	20
3.4.1 RADIATED EMISSION LIMITS	20
3.4.2 TEST PROCEDURE	21
3.4.3 DEVIATION FROM TEST STANDARD	21
3.4.4 TEST RESULTS (BELOW 30MHz)	24
3.4.5 TEST RESULTS (BELOW 1000 MHz)	25
3.4.6 TEST RESULTS (ABOVE 1000 MHz)	27
3.4.7 TEST RESULTS (RESTRICTED BANDS REQUIREMENTS)	33
<b>4 . BANDWIDTH TEST</b>	<b>37</b>
4.1 TEST PROCEDURE	37
4.2 DEVIATION FROM STANDARD	37
4.3 TEST SETUP	37
4.4 TEST RESULTS	38

## 1. SUMMARY OF TEST RESULTS

Test procedures according to the technical standards:

<b>FCC Part15, Subpart C (15.249)</b>			
Standard Section	Test Item	Judgment	Remark
15.207	Conducted Emission	Pass	
15.203	Antenna Requirement	Pass	
15.249	Radiated Spurious Emission	Pass	
15.249	Fundamental Measurement	Pass	
15.205	Band Edge Emission	Pass	
15.249	Occupied Bandwidth	Pass	

### 1.1 TEST FACILITY

Shenzhen NTEK Testing Technology Co., Ltd

Add. : 1/F, Building E, Fenda Science Park, Sanwei Community, Xixiang Street, Bao'an District, Shenzhen 518126 P.R. China.

FCC FRN Registration No.:463705; IC Registration No.:9270A-1

CNAS Registration No.:L5516

### 1.2 MEASUREMENT UNCERTAINTY

The reported uncertainty of measurement  $y \pm U$ , where expanded uncertainty  $U$  is based on a standard uncertainty multiplied by a coverage factor of  $k=2$ , providing a level of confidence of approximately **95 %**.

No.	Item	Uncertainty
1	Conducted Emission Test	$\pm 1.38\text{dB}$
2	RF power,conducted	$\pm 0.16\text{dB}$
3	Spurious emissions,conducted	$\pm 0.21\text{dB}$
4	All emissions,radiated(<1G)	$\pm 4.68\text{dB}$
5	All emissions,radiated(>1G)	$\pm 4.89\text{dB}$
6	Temperature	$\pm 0.5^\circ\text{C}$
7	Humidity	$\pm 2\%$

## 2. GENERAL INFORMATION

### 2.1 GENERAL DESCRIPTION OF EUT

Equipment	Remote Controller
Trade Mark	PIQS
Model Name	M3
Serial Model	N/A
Model Difference	N/A
Product Description	The EUT is a Remote Controller
	Operation Frequency: 2402-2480MHz
	Modulation Type: GFSK
	Antenna Designation: PCB Antenna
	Antenna Gain(Peak) 1 dBi
	Based on the application, features, or specification exhibited in User's Manual. More details of EUT technical specification, please refer to the User's Manual.
Channel List	Please refer to the Note 2.
Adapter	N/A
Battery	TX :DC 3.7V,1000mAh

Note:

1. For a more detailed features description, please refer to the manufacturer's specifications or the User's Manual.

2.

Channel	Frequency (MHz)
00	2402
01	2403
.....	.....
.....	.....
.....	...
.....	.....
13	2479
14	2480

3.

Table for Filed Antenna

Ant.	Brand	Model Name	Antenna Type	Connector	Gain (dBi)	NOTE
1	N/A	N/A	PCB Antenna	N/A	1	Antenna

## 2.2 DESCRIPTION OF TEST MODES

To investigate the maximum EMI emission characteristics generates from EUT, the test system was pre-scanning tested base on the consideration of following EUT operation mode or test configuration mode which possible have effect on EMI emission level. Each of these EUT operation mode(s) or test configuration mode(s) mentioned above was evaluated respectively.

Pretest Mode	Description
Mode 1	CH00
Mode 2	CH08
Mode 3	CH14

For Radiated Spurious Emission	
Pretest Mode	Description
Mode 1	CH00
Mode 2	CH08
Mode 3	CH14

For Conducted Emission	
Final Test Mode	Description
Mode 1	CH00
Mode 2	CH08
Mode 3	CH14

Note:

- (1) The measurements are performed at the highest, middle, lowest available channels.
- (2) The EUT use new battery.



### 2.3 BLOCK DIGRAM SHOWING THE CONFIGURATION OF SYSTEM TESTED

Conducted Emission Mode

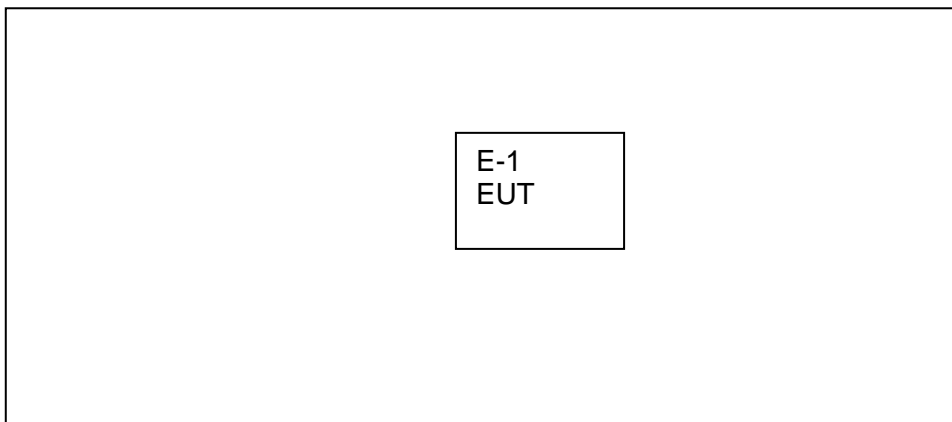

Radiated Spurious Emission Test

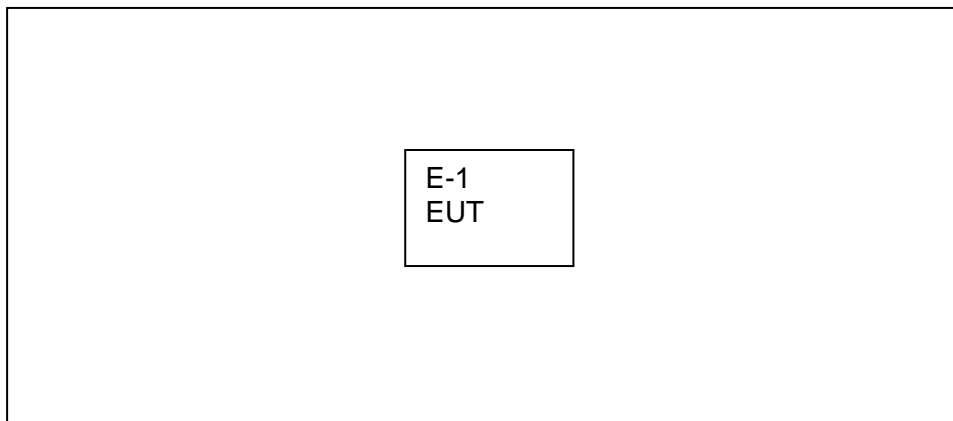

**2.4 DESCRIPTION OF SUPPORT UNITS(CONDUCTED MODE)**

The EUT has been tested as an independent unit together with other necessary accessories or support units. The following support units or accessories were used to form a representative test configuration during the tests.

Item	Equipment	Mfr/Brand	Model/Type No.	Series No.	Note
E-1	Remote Controller	PIQS	M3	N/A	EUT

Item	Cable Type	Shielded Type	Ferrite Core	Length	Note

Note:

- (1) The support equipment was authorized by Declaration of Confirmation.
- (2) For detachable type I/O cable should be specified the length in cm in 『Length』 column.

**2.5 EQUIPMENTS LIST FOR ALL TEST ITEMS**
**Radiation Test equipment**

Item	Kind of Equipment	Manufacturer	Type No.	Serial No.	Last calibration	Calibrated until	Calibration period
1	Spectrum Analyzer	Agilent	E4407B	MY45108040	2017.06.06	2018.06.05	1 year
2	Spectrum Analyzer	Agilent	N9020A	MY49100060	2017.11.10	2018.11.09	1 year
3	EMI Test Receiver	Agilent	N9038A	MY53227146	2017.06.06	2018.06.05	1 year
4	Test Receiver	R&S	ESPI	101318	2017.06.06	2018.06.05	1 year
5	Bilog Antenna	TESEQ	CBL6111D	31216	2017.04.09	2018.04.08	1 year
6	50Ω Coaxial Switch	Anritsu	MP59B	6200983705	2017.06.06	2018.06.05	1 year
7	Horn Antenna	EM	EM-AH-10180	2011071402	2017.04.09	2018.04.08	1 year
8	Horn Ant	Schwarzbeck	BBHA 9170	9170-181	2017.07.06	2018.07.05	1 year
9	Amplifier	EMC	EMC051835SE	980246	2017.08.09	2018.08.08	1 year
10	Amplifier	MITEQ	TTA1840-35-HG	177156	2017.06.06	2018.06.05	1 year
11	Loop Antenna	ARA	PLA-1030/B	1029	2017.06.06	2018.06.05	1 year
12	Power Meter	DARE	RPR3006W	15I00041S NO84	2017.08.07	2018.08.06	1 year
13	Test Cable (9KHz-30MHz)	N/A	R-01	N/A	2017.04.21	2020.04.20	3 year
14	Test Cable (30MHz-1GHz)	N/A	R-02	N/A	2017.04.21	2020.04.20	3 year
15	High Test Cable(1G-40GHz)	N/A	R-03	N/A	2017.04.21	2020.04.20	3 year
16	High Test Cable(1G-40GHz)	N/A	R-04	N/A	2017.04.21	2020.04.20	3 year
17	temporary antenna connector (Note)	NTS	R001	N/A	N/A	N/A	N/A

**Note:**

We will use the temporary antenna connector (soldered on the PCB board) When conducted test  
 And this temporary antenna connector is listed within the instrument list

**Conduction Test equipment**

Item	Kind of Equipment	Manufacturer	Type No.	Serial No.	Last calibration	Calibrated until	Calibration period
1	Test Receiver	R&S	ESCI	101160	2017.06.06	2018.06.05	1 year
2	LISN	R&S	ENV216	101313	2017.04.19	2018.04.18	1 year
3	LISN	SCHWARZBECK	NNLK 8129	8129245	2017.06.06	2018.06.05	1 year
4	50Ω Coaxial Switch	ANRITSU CORP	MP59B	6200983704	2017.06.06	2018.06.05	1 year
5	Test Cable (9KHz-30MHz)	N/A	C01	N/A	2017.04.21	2020.04.20	3 year
6	Test Cable (9KHz-30MHz)	N/A	C02	N/A	2017.04.21	2020.04.20	3 year
7	Test Cable (9KHz-30MHz)	N/A	C03	N/A	2017.04.21	2020.04.20	3 year

Note: Each piece of equipment is scheduled for calibration once a year.

### 3. ANTENNA REQUIREMENT

#### 3.1 STANDARD REQUIREMENT

15.203 requirement: For intentional device, according to 15.203: an intentional radiator shall be designed to ensure that no antenna other than that furnished by the responsible party shall be used with the device.

#### 3.2 EUT ANTENNA

The EUT antenna is permanent attached Cable antenna(Gain:1dBi). It comply with the standard requirement.

### 3.3 CONDUCTED EMISSION MEASUREMENT

#### 3.3.1 POWER LINE CONDUCTED EMISSION Limits (Frequency Range 150KHz-30MHz)

FREQUENCY (MHz)	Class A (dBuV)		Class B (dBuV)		Standard
	Quasi-peak	Average	Quasi-peak	Average	
0.15 -0.5			66 - 56 *	56 - 46 *	CISPR
0.50 -5.0			56.00	46.00	CISPR
5.0 -30.0			60.00	50.00	CISPR

0.15 -0.5			66 - 56 *	56 - 46 *	LP002.
0.50 -5.0			56.00	46.00	LP002.
5.0 -30.0			60.00	50.00	LP002.

Note:

- (1) The tighter limit applies at the band edges.
- (2) The limit of " \* " marked band means the limitation decreases linearly with the logarithm of the frequency in the range.

The following table is the setting of the receiver

Receiver Parameters	Setting
Attenuation	10 dB
Start Frequency	0.15 MHz
Stop Frequency	30 MHz
IF Bandwidth	9 kHz

**3.3.2 TEST PROCEDURE**

- a. The EUT was placed 0.4 meters from the horizontal ground plane with EUT being connected to the power mains through a line impedance stabilization network (LISN). All other support equipments powered from additional LISN(s). The LISN provide 50 Ohm/ 50uH of coupling impedance for the measuring instrument.
- b. Interconnecting cables that hang closer than 40 cm to the ground plane shall be folded back and forth in the center forming a bundle 30 to 40 cm long.
- c. I/O cables that are not connected to a peripheral shall be bundled in the center. The end of the cable may be terminated, if required, using the correct terminating impedance. The overall length shall not exceed 1 m.
- d. LISN at least 80 cm from nearest part of EUT chassis.
- e. For the actual test configuration, please refer to the related Item –EUT Test Photos.

**3.3.3 DEVIATION FROM TEST STANDARD**

No deviation

**3.3.4 TEST SETUP**

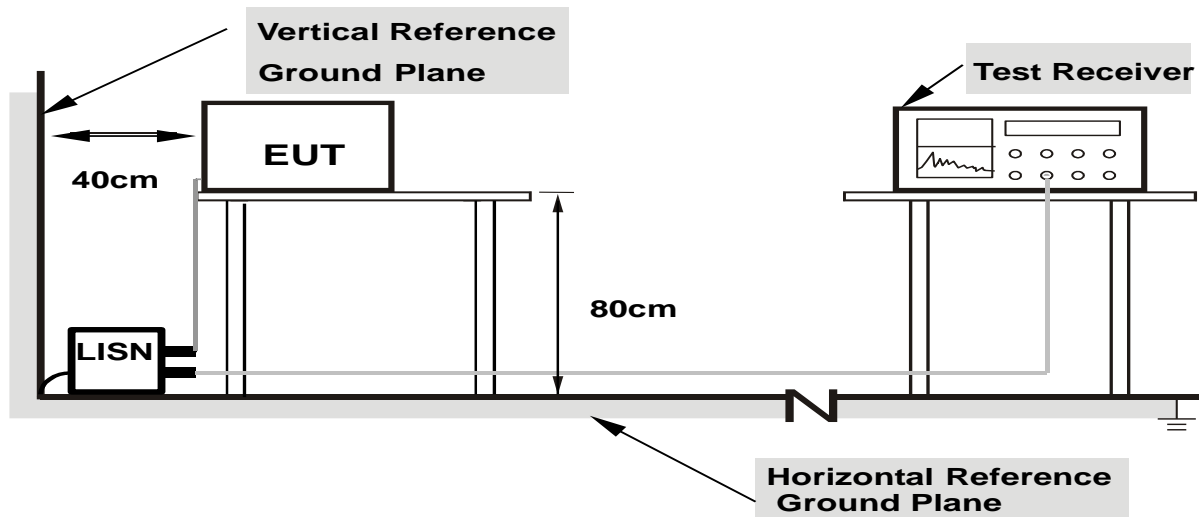

- Note:**
- 1. Support units were connected to second LISN.
  - 2. Both of LISNs (AMN) are 80 cm from EUT and at least 80 from other units and other metal planes

### 3.2.5 TEST RESULT

EUT :	Remote Controller	Model Name. :	M3
Temperature :	26 °C	Relative Humidity :	60%
Pressure :	1010hPa	Phase :	L
Test Voltage :	DC 3.7V from adapter AC 120V/60Hz	Test Mode :	Model 1

Frequency (MHz)	Reading Level (dBμV)	Correct Factor (dB)	Measure-ment (dBμV)	Limits (dBμV)	Margin (dB)	Remark
0.4099	20.14	9.83	29.97	57.65	-27.68	QP
0.4099	3.47	9.83	13.3	47.65	-34.35	AVG
0.538	24.18	9.83	34.01	56	-21.99	QP
0.538	15.37	9.83	25.2	46	-20.8	AVG
0.802	18.84	9.86	28.7	56	-27.3	QP
0.802	6.44	9.86	16.3	46	-29.7	AVG
6.0058	18.07	10.01	28.08	60	-31.92	QP
6.0058	10.09	10.01	20.1	50	-29.9	AVG
9.0498	19.65	9.98	29.63	60	-30.37	QP
9.0498	11.32	9.98	21.3	50	-28.7	AVG
16.2619	17.46	10.23	27.69	60	-32.31	QP
16.2619	5.37	10.23	15.6	50	-34.4	AVG

Remark:

1. All readings are Quasi-Peak and Average values.
2. Factor = Insertion Loss + Cable Loss.

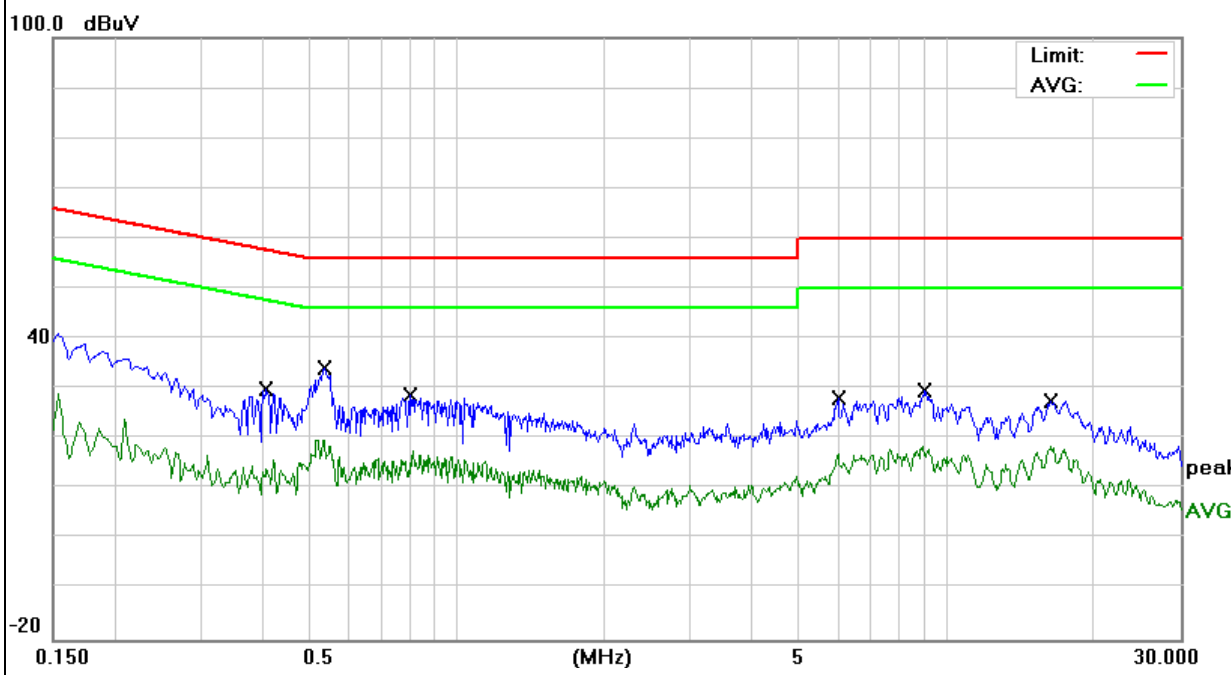



EUT :	Remote Controller	Model Name. :	M3
Temperature :	26 °C	Relative Humidity :	60%
Pressure :	1010hPa	Phase :	N
Test Voltage :	DC 3.7V from adapter AC 120V/60Hz	Test Mode :	Model 1

Frequency (MHz)	Reading Level (dBμV)	Correct Factor (dB)	Measure-ment (dBμV)	Limits (dBμV)	Margin (dB)	Remark
0.442	23.83	9.93	33.76	57.02	-23.26	QP
0.442	12.37	9.93	22.3	47.02	-24.72	AVG
0.538	32.45	9.93	42.38	56	-13.62	QP
0.538	12.22	9.93	22.15	46	-23.85	AVG
0.8739	22.59	9.93	32.52	56	-23.48	QP
0.8739	10.72	9.93	20.65	46	-25.35	AVG
1.502	20.83	9.94	30.77	56	-25.23	QP
1.502	11.41	9.94	21.35	46	-24.65	AVG
2.1939	18.28	9.94	28.22	56	-27.78	QP
2.1939	6.42	9.94	16.36	46	-29.64	AVG
5.2938	16.9	9.97	26.87	60	-33.13	QP
5.2938	4.25	9.97	14.22	50	-35.78	AVG

Remark:

1. All readings are Quasi-Peak and Average values.
2. Factor = Insertion Loss + Cable Loss.

100.0 dBuV

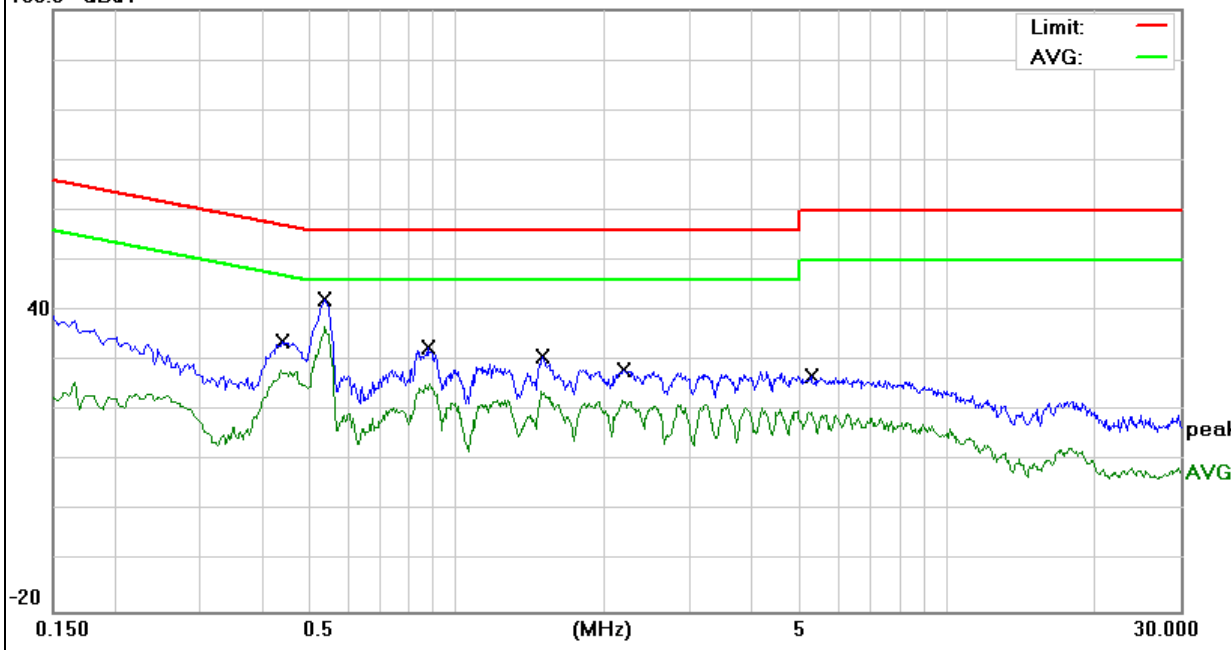

EUT :	Remote Controller	Model Name. :	M3
Temperature :	26 °C	Relative Humidity :	60%
Pressure :	1010hPa	Phase :	L
Test Voltage :	DC 3.7V from adapter AC 230V/50Hz	Test Mode :	Model 1

Frequency (MHz)	Reading Level (dBμV)	Correct Factor (dB)	Measure-ment (dBμV)	Limits (dBμV)	Margin (dB)	Remark
0.3019	19.84	9.82	29.66	60.19	-30.53	QP
0.3019	8.5	9.82	18.32	50.19	-31.87	AVG
0.562	21.19	9.83	31.02	56	-24.98	QP
0.562	6.49	9.83	16.32	46	-29.68	AVG
0.91	15.39	9.9	25.29	56	-30.71	QP
0.91	5.35	9.9	15.25	46	-30.75	AVG
1.858	13.93	9.85	23.78	56	-32.22	QP
1.858	4.17	9.85	14.02	46	-31.98	AVG
3.254	14.59	10.05	24.64	56	-31.36	QP
3.254	3.31	10.05	13.36	46	-32.64	AVG
4.6779	14.65	10.06	24.71	56	-31.29	QP
4.6779	2.19	10.06	12.25	46	-33.75	AVG

Remark:

1. All readings are Quasi-Peak and Average values.
2. Factor = Insertion Loss + Cable Loss.

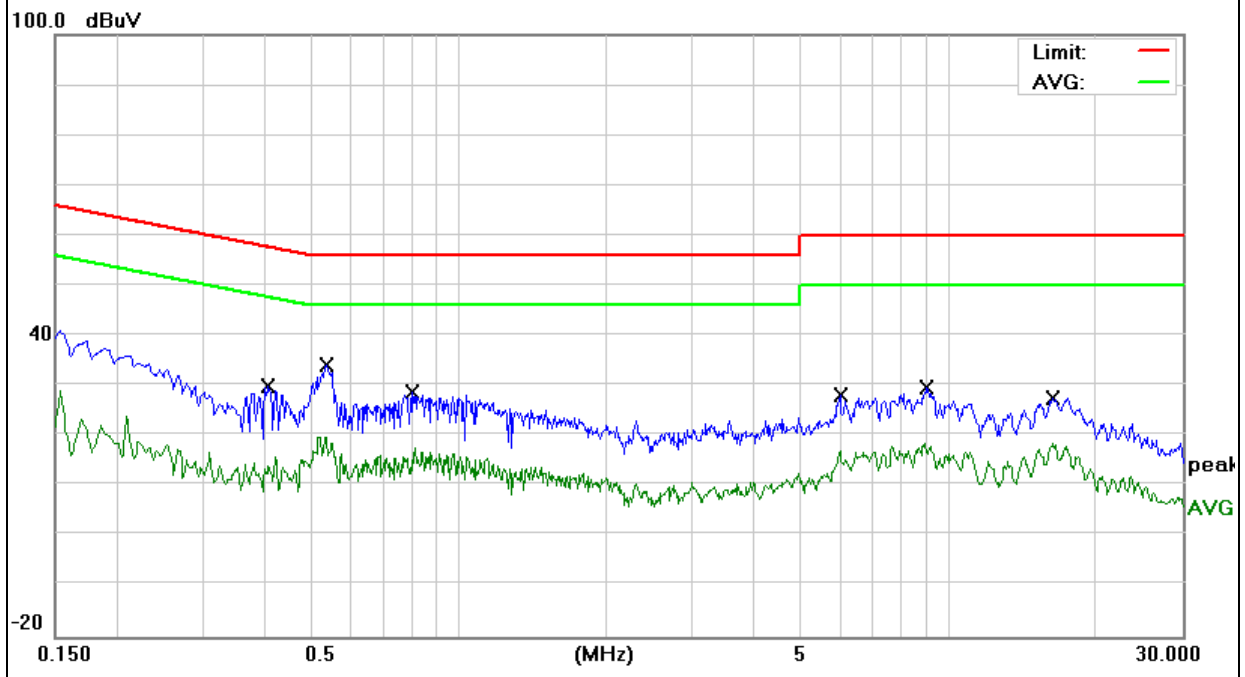

EUT :	Remote Controller	Model Name. :	M3
Temperature :	26 °C	Relative Humidity :	60%
Pressure :	1010hPa	Phase :	N
Test Voltage :	DC 3.7V from adapter AC 230V/50Hz	Test Mode :	Model 1

Frequency (MHz)	Reading Level (dBμV)	Correct Factor (dB)	Measure-ment (dBμV)	Limits (dBμV)	Margin (dB)	Remark
0.4219	25.42	9.93	35.35	57.41	-22.06	QP
0.4219	10.32	9.93	20.25	47.41	-27.16	AVG
0.55	30.55	9.93	40.48	56	-15.52	QP
0.55	13.43	9.93	23.36	46	-22.64	AVG
0.9979	24.63	9.93	34.56	56	-21.44	QP
0.9979	11.29	9.93	21.22	46	-24.78	AVG
1.7059	22.32	9.94	32.26	56	-23.74	QP
1.7059	10.31	9.94	20.25	46	-25.75	AVG
2.362	21.38	9.94	31.32	56	-24.68	QP
2.362	14.38	9.94	24.32	46	-21.68	AVG
3.0739	21.01	9.95	30.96	56	-25.04	QP
3.0739	13.07	9.95	23.02	46	-22.98	AVG

Remark:

1. All readings are Quasi-Peak and Average values.
2. Factor = Insertion Loss + Cable Loss.

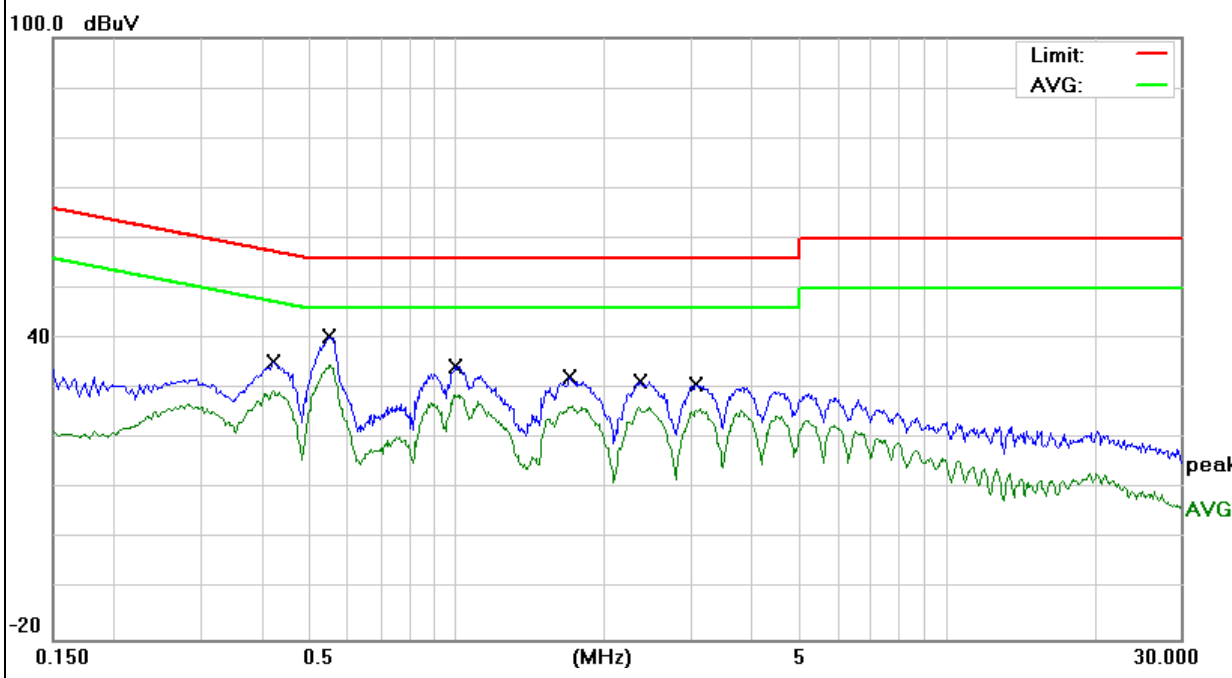

### 3.4 RADIATED EMISSION MEASUREMENT

#### 3.4.1 Radiated Emission Limits ( FCC 15.209 )

Frequencies (MHz)	Field Strength (micorvolts/meter)	Measurement Distance (meters)
0.009~0.490	2400/F(KHz)	300
0.490~1.705	24000/F(KHz)	30
1.705~30.0	30	30
Frequency (MHz)	Limit (dBuV)	
30~88	40	3
88~216	43.5	3
216~960	46	3
960 -10000	54.00	3
*902 - 928	94.00	3

Note:

- (1) The tighter limit applies at the band edges.
- (2) Emission level (dBuV/m)=20log Emission level (uV/m).
- (3) \*Note: This is the limit for the fundamental frequency.

#### LIMITS OF RADIATED EMISSION MEASUREMENT ( FCC 15.249)

Frequency of Emission (MHz)	Field Strength of fundamental ((millivolts /meter)	Field Strength of Harmonics (microvolts/meter)
902-928	50	500

Notes:

- (1) Emissions radiated outside of the specified frequency bands, except for harmonics, shall be attenuated by at least 50 dB below the level of the fundamental or to the general radiated emission limits in Section 15.209, whichever is the lesser attenuation.

Spectrum Parameter	Setting
Attenuation	Auto
Start Frequency	1000 MHz
Stop Frequency	10th carrier harmonic
RB / VB (emission in restricted band)	1MHz / 1MHz for Peak

Receiver Parameter	Setting
Attenuation	Auto
Start ~ Stop Frequency	9kHz~150kHz / RB 200Hz for QP
Start ~ Stop Frequency	150kHz~30MHz / RB 9kHz for QP
Start ~ Stop Frequency	30MHz~1000MHz / RB 120kHz for QP

### 3.4.2 TEST PROCEDURE

- a. The measuring distance of at 3 m shall be used for measurements at frequency up to 1GHz. For frequencies above 1GHz, any suitable measuring distance may be used.
- b. The EUT was placed on the top of a rotating table 0.8 m for below 1GHz and 1.5m for above 1GHz the ground at a 3 meter. The table was rotated 360 degrees to determine the position of the highest radiation.
- c. The height of the equipment or of the substitution antenna shall be 0.8 m for below 1GHz and 1.5m for above 1GHz; the height of the test antenna shall vary between 1 m to 4 m. Both horizontal and vertical polarizations of the antenna are set to make the measurement.
- d. The initial step in collecting conducted emission data is a spectrum analyzer peak detector mode pre-scanning the measurement frequency range. Significant peaks are then marked and then Quasi Peak detector mode re-measured.
- e. If the Peak Mode measured value compliance with and lower than Quasi Peak Mode Limit, the EUT shall be deemed to meet QP Limits and then no additional QP Mode measurement performed.
- f. For the actual test configuration, please refer to the related Item –EUT Test Photos.

Note:

Both horizontal and vertical antenna polarities were tested and performed pretest to three orthogonal axis. The worst case emissions were reported

### 3.4.3 DEVIATION FROM TEST STANDARD

No deviation

(A) Radiated Emission Test-Up Frequency Below 30MHz

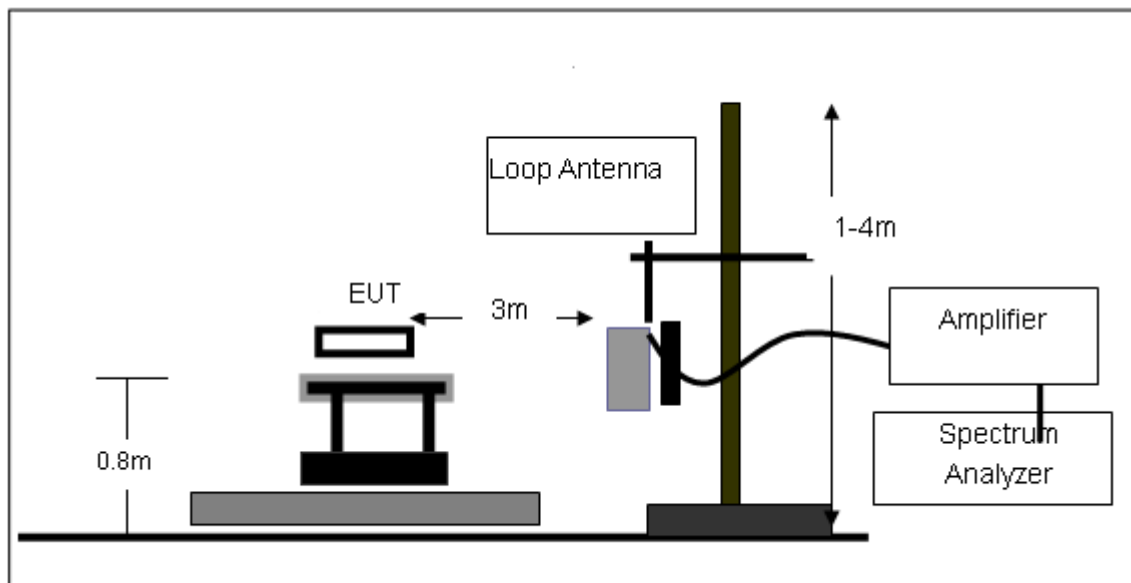

(B) Radiated Emission Test-Up Frequency 30MHz~1GHz

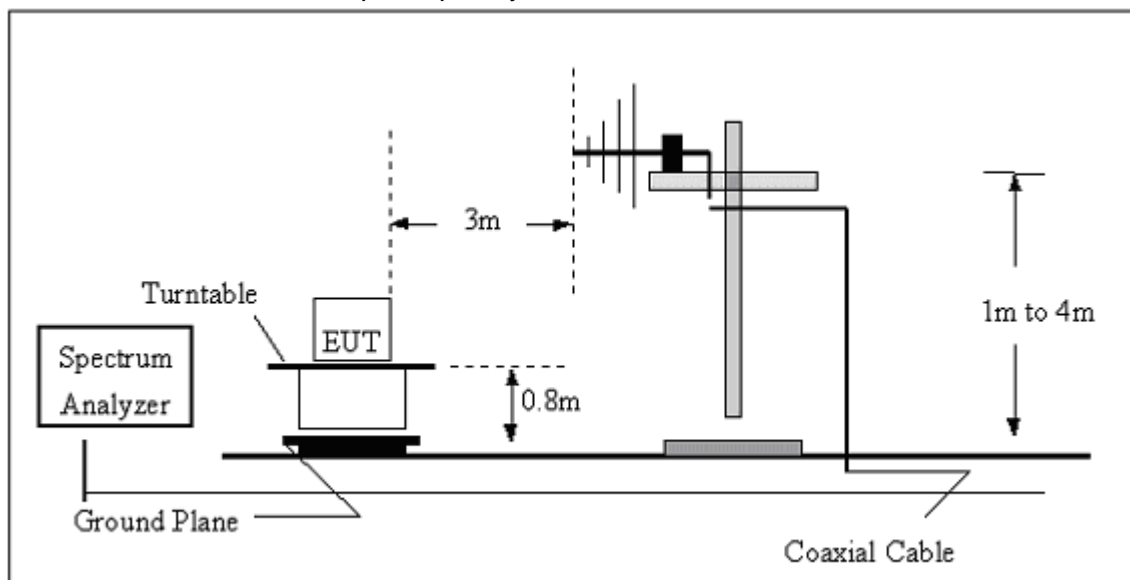

(C) Radiated Emission Test-Up Frequency Above 1GHz

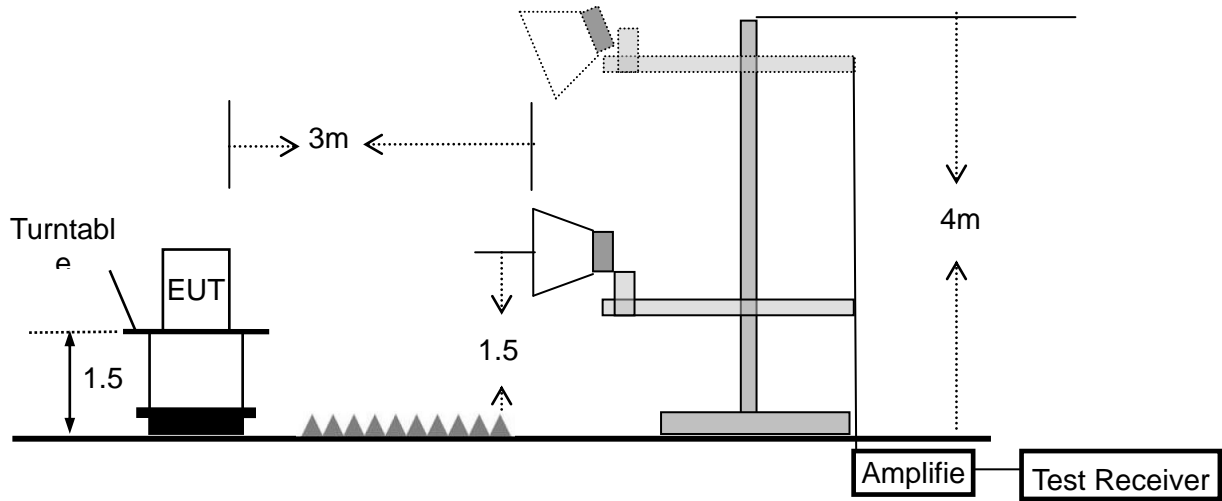

### 3.4.4 TEST RESULTS (BELOW 30MHz)

EUT :	Remote Controller	Model Name. :	M3
Temperature :	20 °C	Relative Humidity :	48%
Pressure :	1010 hPa	Test Voltage :	DC 3.7V
Test Mode :	TX	Polarization :	--

Freq.	Reading	Limit	Margin	State
(MHz)	(dBuV/m)	(dBuV/m)	(dB)	P/F
--	--	--	--	PASS
--	--	--	--	PASS

**NOTE:**

The amplitude of spurious emissions which are attenuated by more than 20dB below the permissible value has no need to be reported.

Distance extrapolation factor =  $20 \log(\text{specific distance}/\text{test distance})$ (dB);

Limit line = specific limits(dBuv) + distance extrapolation factor.



### 3.4.5 TEST RESULTS (BELOW 1000 MHz)

EUT :	Remote Controller	Model Name :	M3
Temperature :	25 °C	Relative Humidity :	55%
Pressure :	1010 hPa	Test Voltage :	DC 3.7V
Test Mode :	Model 1	Polarization :	Vertical

Frequency (MHz)	Meter Reading (dB $\mu$ V)	Factor (dB)	Emission Level (dB $\mu$ V/m)	Limits (dB $\mu$ V/m)	Margin (dB)	Detector Type
36.3814	12.68	18.28	30.96	40	-9.04	QP
50.2324	14.71	13.33	28.04	40	-11.96	QP
70.5836	18.03	10.57	28.6	40	-11.4	QP
94.0979	20.33	12.05	32.38	43.5	-11.12	QP
164.9075	19.82	12.47	32.29	43.5	-11.21	QP
193.0945	15.96	13.36	29.32	43.5	-14.18	QP

Remark:

- Factor = Antenna Factor + Cable Loss – Pre-amplifier.

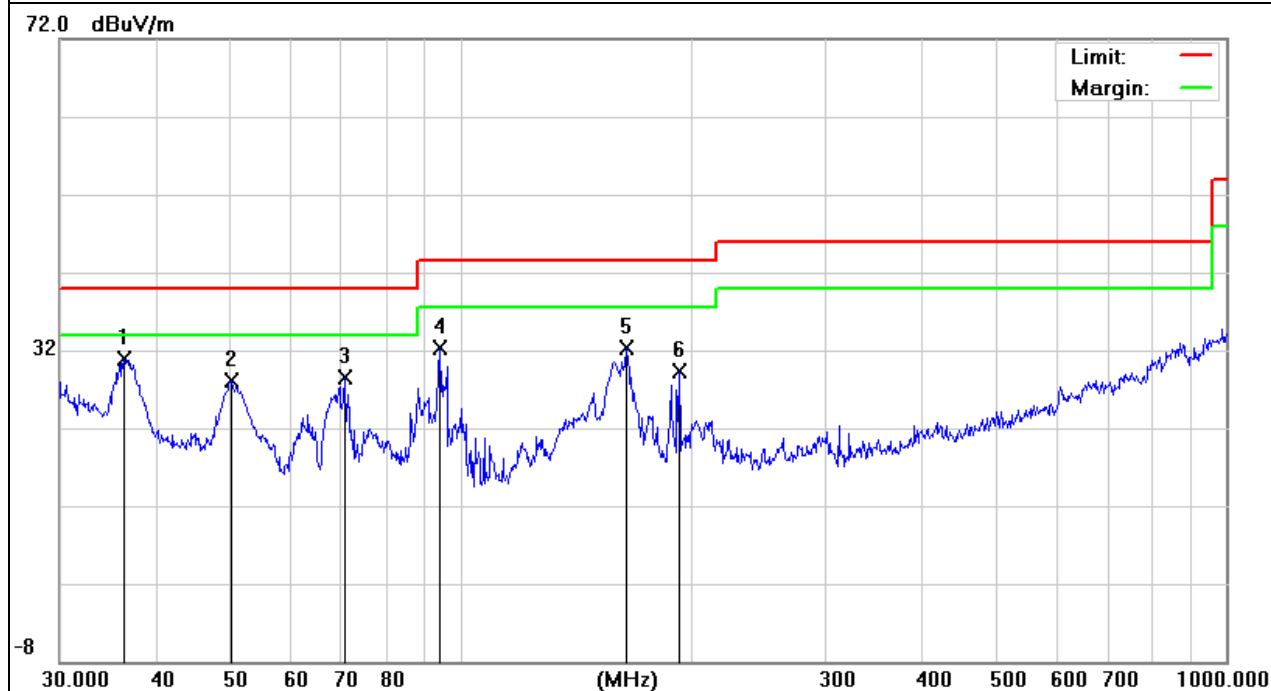

EUT :	Remote Controller	Model Name :	M3
Temperature :	25 °C	Relative Humidity :	55%
Pressure :	1010 hPa	Test Voltage :	DC 3.7V
Test Mode :	Model 1	Polarization :	Horizontal

Frequency (MHz)	Meter Reading (dBμV)	Factor (dB)	Emission Level (dBμV/m)	Limits (dBμV/m)	Margin (dB)	Detector Type
30	5.34	21.2	26.54	40	-13.46	QP
36.7661	8.03	18.09	26.12	40	-13.88	QP
50.7637	9.41	13.31	22.72	40	-17.28	QP
93.7685	10.95	12.03	22.98	43.5	-20.52	QP
158.1123	12.98	11.84	24.82	43.5	-18.68	QP
256.5211	11.44	12.65	24.09	46	-21.91	QP

Remark:

1. Factor = Antenna Factor + Cable Loss – Pre-amplifier.

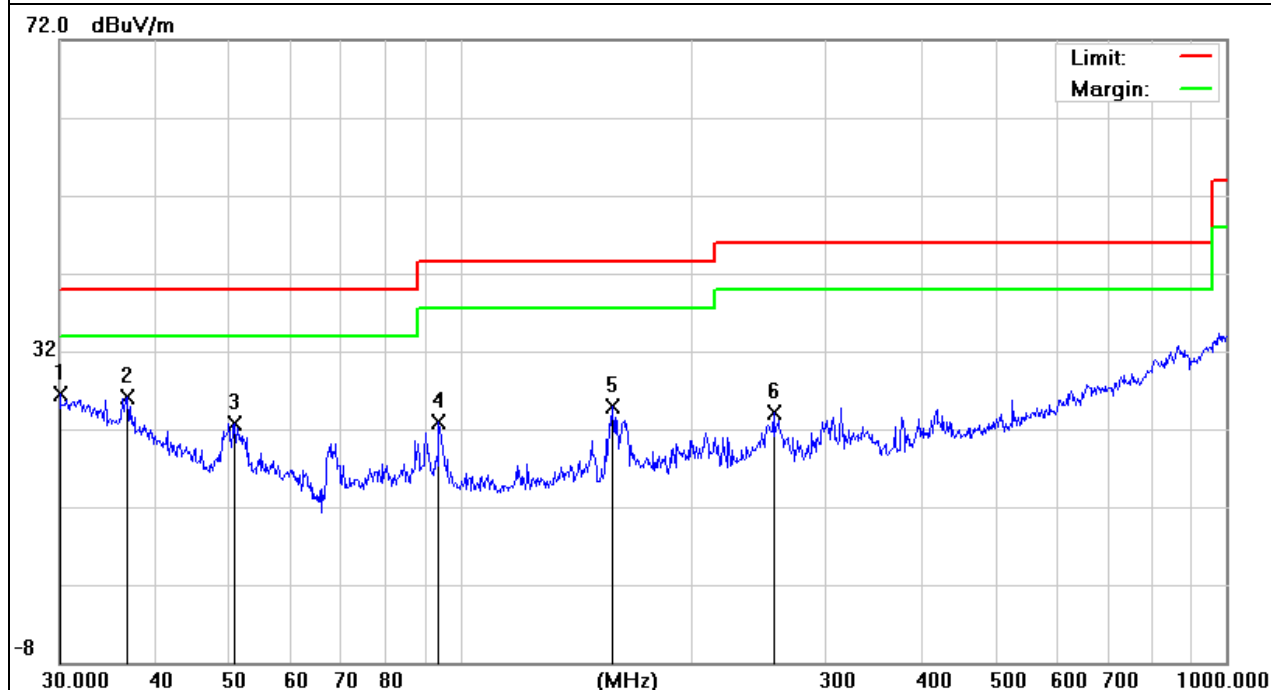

### 3.4.6 TEST RESULTS (ABOVE 1000 MHZ)

EUT :	Remote Controller	Model Name :	M3
Temperature :	25 °C	Relative Humidity :	55%
Pressure :	1010 hPa	Test Voltage :	DC 3.7V
Test Mode :	Model 1	Polarization :	Horizontal

Frequency (MHz)	Meter Reading (dBμV)	Factor (dB)	Emission Level (dBμV/m)	Limits (dBμV/m)	Margin (dB)	Detector Type
4797.172	49.55	-2.73	46.82	74	-27.18	peak
4797.172	38.97	-2.65	36.32	54	-17.68	AVG
7189.91	40.4	-0.34	40.06	74	-33.94	peak
7189.91	30.35	-0.33	30.02	54	-23.98	AVG

Remark:  
 Factor = Antenna Factor + Cable Loss – Pre-amplifier.  
 No emission above 18GHz.

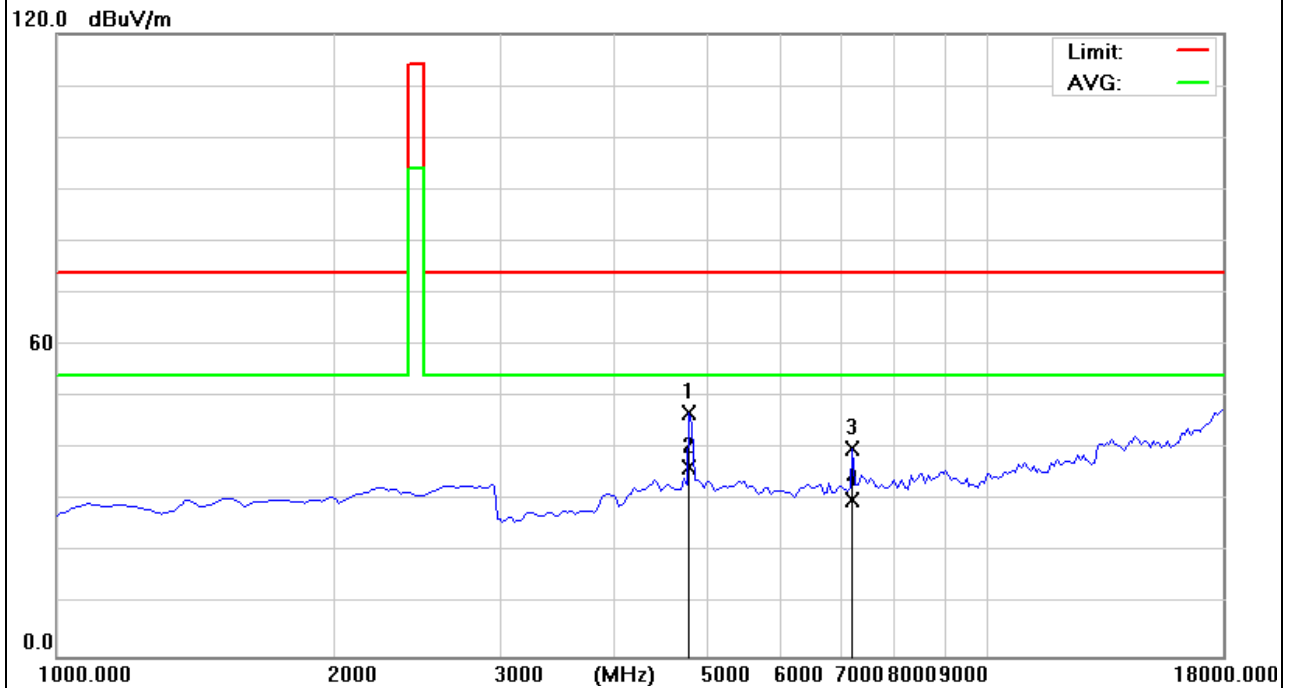

EUT :	Remote Controller	Model Name :	M3
Temperature :	25 °C	Relative Humidity :	55%
Pressure :	1010 hPa	Test Voltage :	DC 3.7V
Test Mode :	Model 1	Polarization :	Vertical

Frequency (MHz)	Meter Reading (dB $\mu$ V)	Factor (dB)	Emission Level (dB $\mu$ V/m)	Limits (dB $\mu$ V/m)	Margin (dB)	Detector Type
4797.172	42.02	-2.73	39.29	74	-34.71	peak
4797.172	27.75	-2.73	25.02	54	-28.98	AVG
7189.91	37.22	-0.34	36.88	74	-37.12	peak
7189.91	23.7	-0.34	23.36	54	-30.64	AVG

**Remark:**

Factor = Antenna Factor + Cable Loss – Pre-amplifier.

No emission above 18GHz.

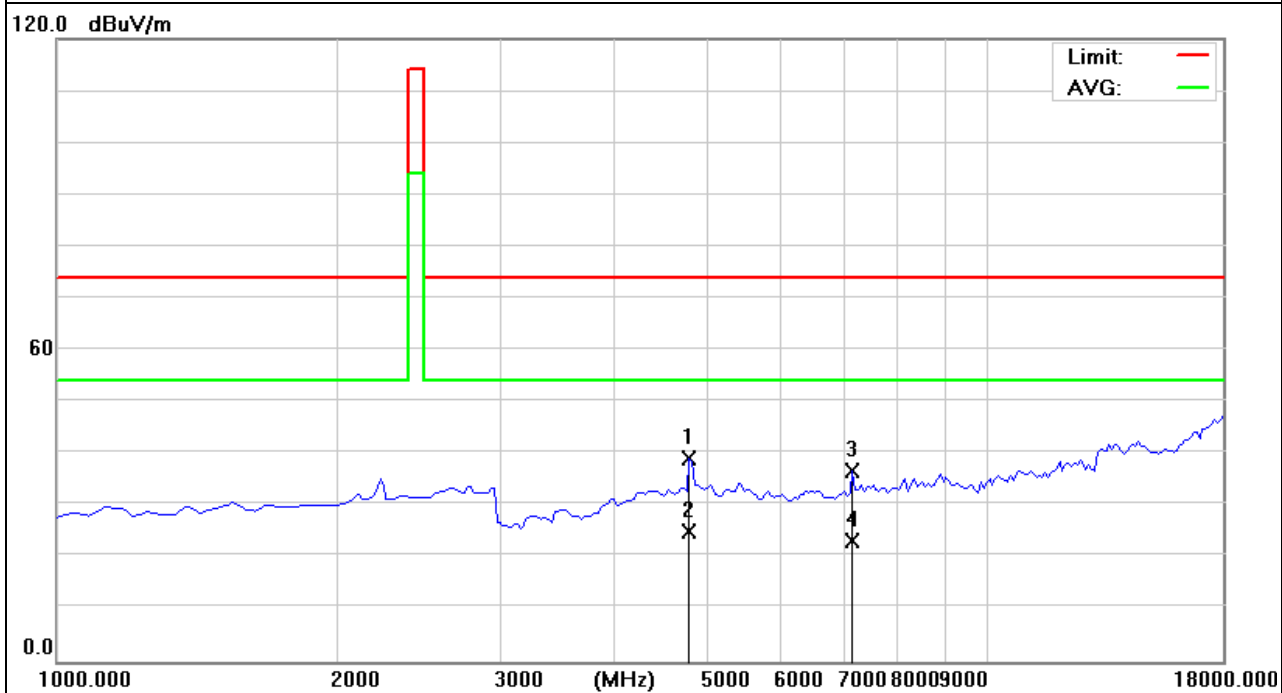

EUT :	Remote Controller	Model Name :	M3
Temperature :	25 °C	Relative Humidity :	55%
Pressure :	1010 hPa	Test Voltage :	DC 3.7V
Test Mode :	Model 2	Polarization :	Horizontal

Frequency (MHz)	Meter Reading (dBμV)	Factor (dB)	Emission Level (dBμV/m)	Limits (dBμV/m)	Margin (dB)	Detector Type
4867.004	32.53	-2.51	30.02	54	-23.98	peak
4867.004	47.43	-2.51	44.92	74	-29.08	AVG
7294.573	36.45	-0.14	36.31	74	-37.69	peak
7294.573	25.39	-0.14	25.25	54	-28.75	AVG

Remark:  
 Factor = Antenna Factor + Cable Loss – Pre-amplifier.  
 No emission above 18GHz.

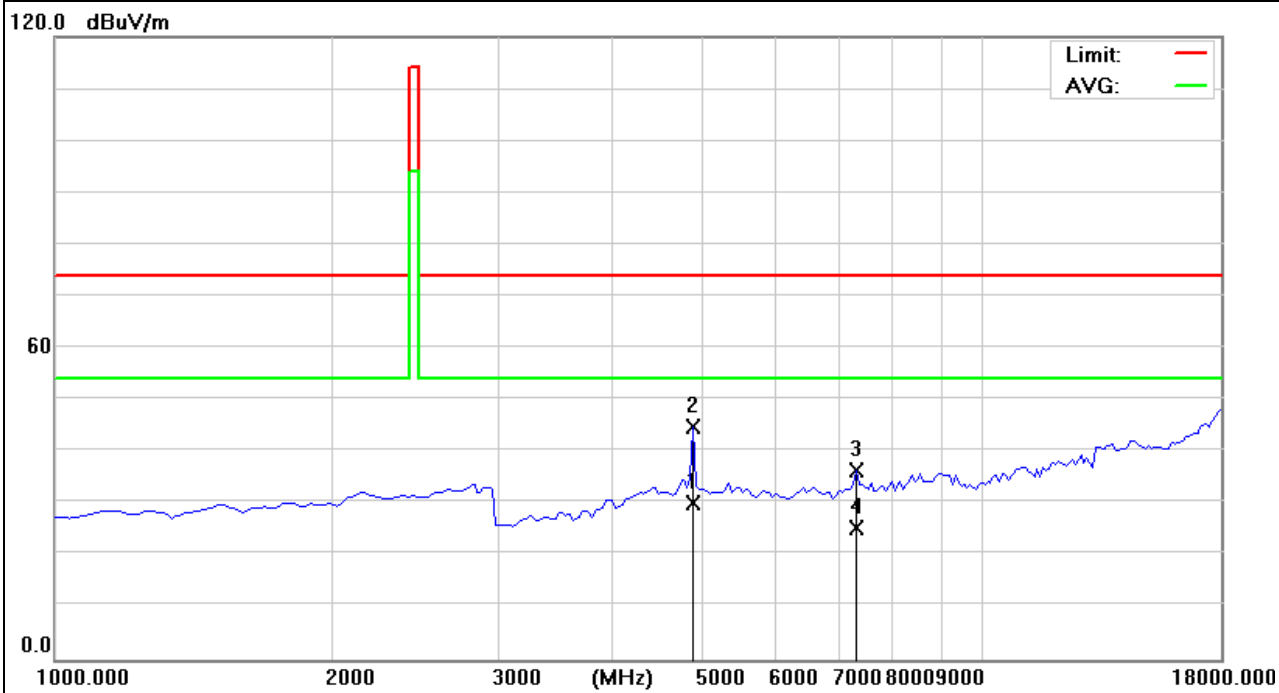

EUT :	Remote Controller	Model Name :	M3
Temperature :	25 °C	Relative Humidity :	55%
Pressure :	1010 hPa	Test Voltage :	DC 3.7V
Test Mode :	Model 2	Polarization :	Vertical

Frequency (MHz)	Meter Reading (dBμV)	Factor (dB)	Emission Level (dBμV/m)	Limits (dBμV/m)	Margin (dB)	Detector Type
4867.004	29.2	-2.51	26.69	54	-27.31	peak
4867.004	42.36	-2.51	39.85	74	-34.15	AVG
7294.573	35.72	-0.14	35.58	74	-38.42	peak
7294.573	25.59	-0.14	25.45	54	-28.55	AVG

Remark:  
 Factor = Antenna Factor + Cable Loss – Pre-amplifier.  
 No emission above 18GHz.

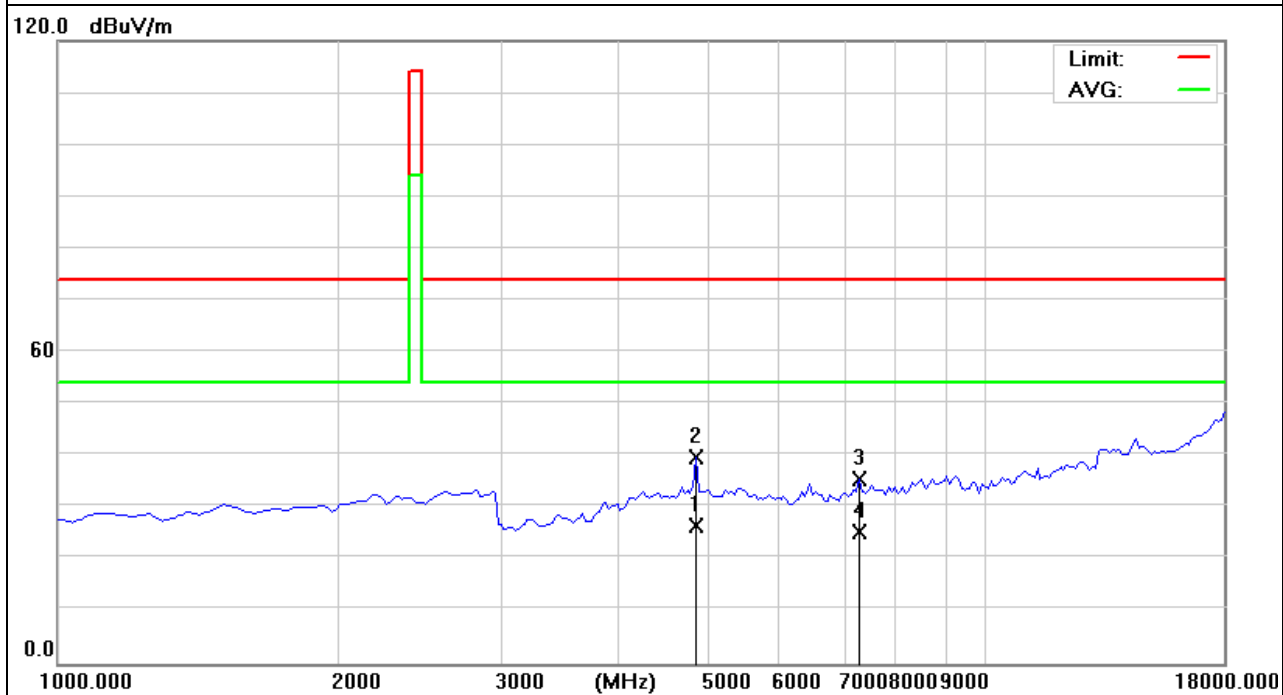

EUT :	Remote Controller	Model Name :	M3
Temperature :	20 °C	Relative Humidity :	48%
Pressure :	1010 hPa	Test Voltage :	DC 3.7V
Test Mode :	Model 3	Polarization :	Horizontal

Frequency (MHz)	Meter Reading (dBμV)	Factor (dB)	Emission Level (dBμV/m)	Limits (dBμV/m)	Margin (dB)	Detector Type
4952.5	45.68	-2.26	43.42	74	-30.58	peak
4952.5	31.58	-2.26	29.32	54	-24.68	AVG
7460	38.76	0.04	38.8	74	-35.2	peak
7460	28.21	0.04	28.25	54	-25.75	AVG

Remark:  
 Factor = Antenna Factor + Cable Loss – Pre-amplifier.  
 No emission above 18GHz.

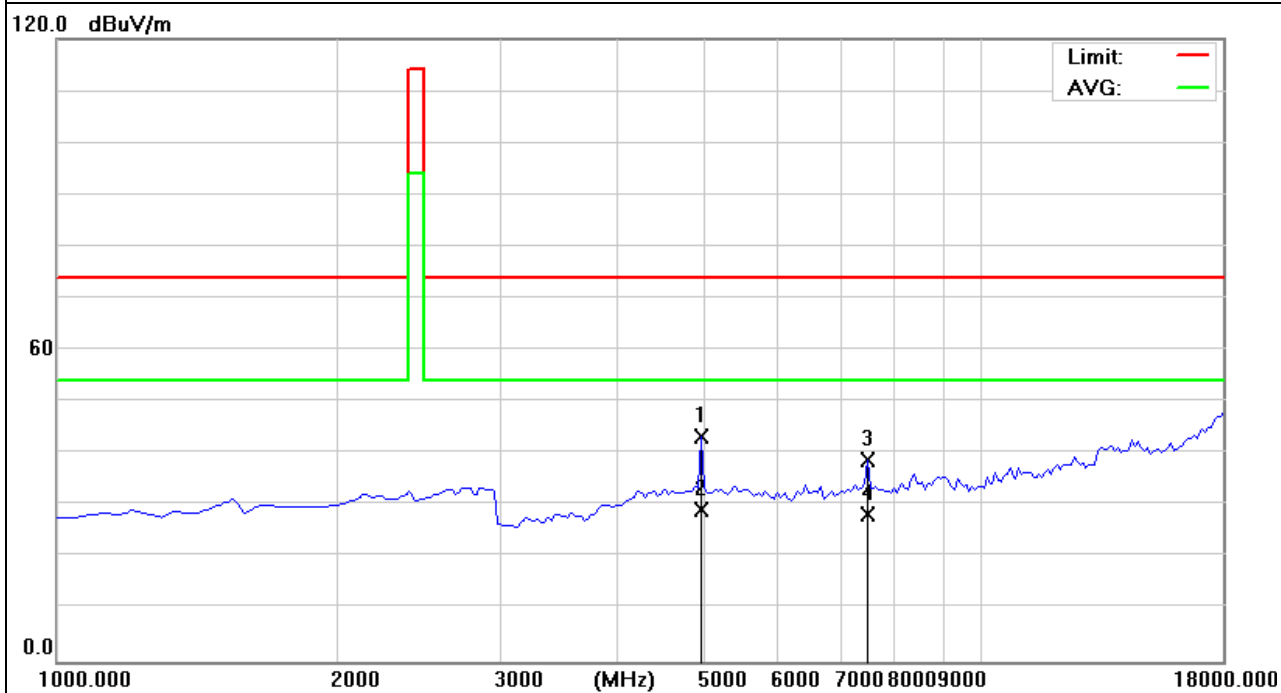

EUT :	Remote Controller	Model Name :	M3
Temperature :	25 °C	Relative Humidity :	55%
Pressure :	1010 hPa	Test Voltage :	DC 3.7V
Test Mode :	Model 3	Polarization :	Vertical

Frequency (MHz)	Meter Reading (dBμV)	Factor (dB)	Emission Level (dBμV/m)	Limits (dBμV/m)	Margin (dB)	Detector Type
4952.5	39.59	-2.26	37.33	74	-36.67	peak
4952.5	27.58	-2.26	25.32	54	-28.68	AVG
7460	35.61	0.04	35.65	74	-38.35	peak
7460	24.48	0.04	24.52	54	-29.48	AVG

Remark:  
 Factor = Antenna Factor + Cable Loss – Pre-amplifier.  
 No emission above 18GHz.

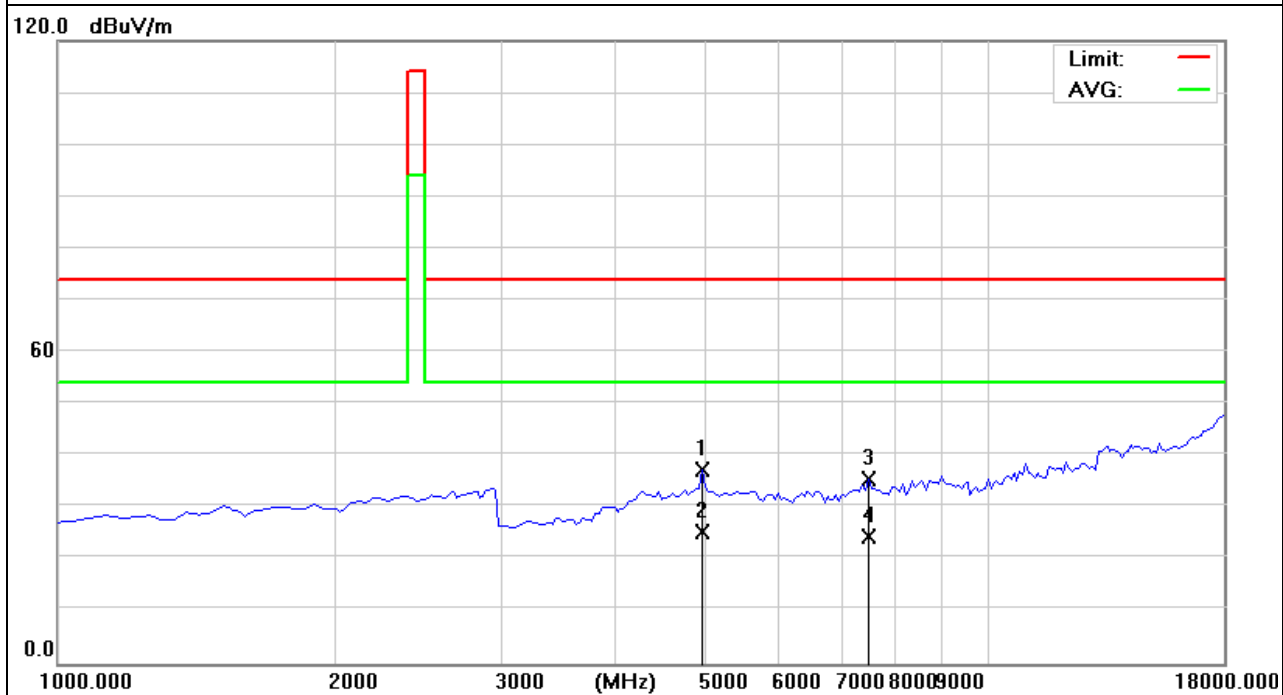

Note: EUT Pre-scan X/Y/Z orientation, only worst case is presented in the report(X orientation).



### 3.4.7 TEST RESULTS (RESTRICTED BANDS REQUIREMENTS)

EUT :	Remote Controller	Model Name :	M3
Temperature :	25 °C	Relative Humidity :	55%
Pressure :	1010 hPa	Test Voltage :	DC 3.7V
Test Mode :	TX	Polarization :	Horizontal

Frequency (MHz)	Meter Reading (dBμV)	Factor (dB)	Emission Level (dBμV/m)	Limits (dBμV/m)	Margin (dB)	Detector Type
2480	77.18	-10.59	66.59	114.0 0	-47.41	peak
2480	64.84	-10.59	54.25	94	-39.75	AVG
2483.5	45.21	-10.63	34.58	74	-39.42	peak
2483.5	30.85	-10.63	20.22	54	-33.78	AVG
2486.375	47.95	-10.66	37.29	74	-36.71	peak
2486.375	36.98	-10.66	26.32	54	-27.68	AVG

Remark:  
Factor = Antenna Factor + Cable Loss – Pre-amplifier.

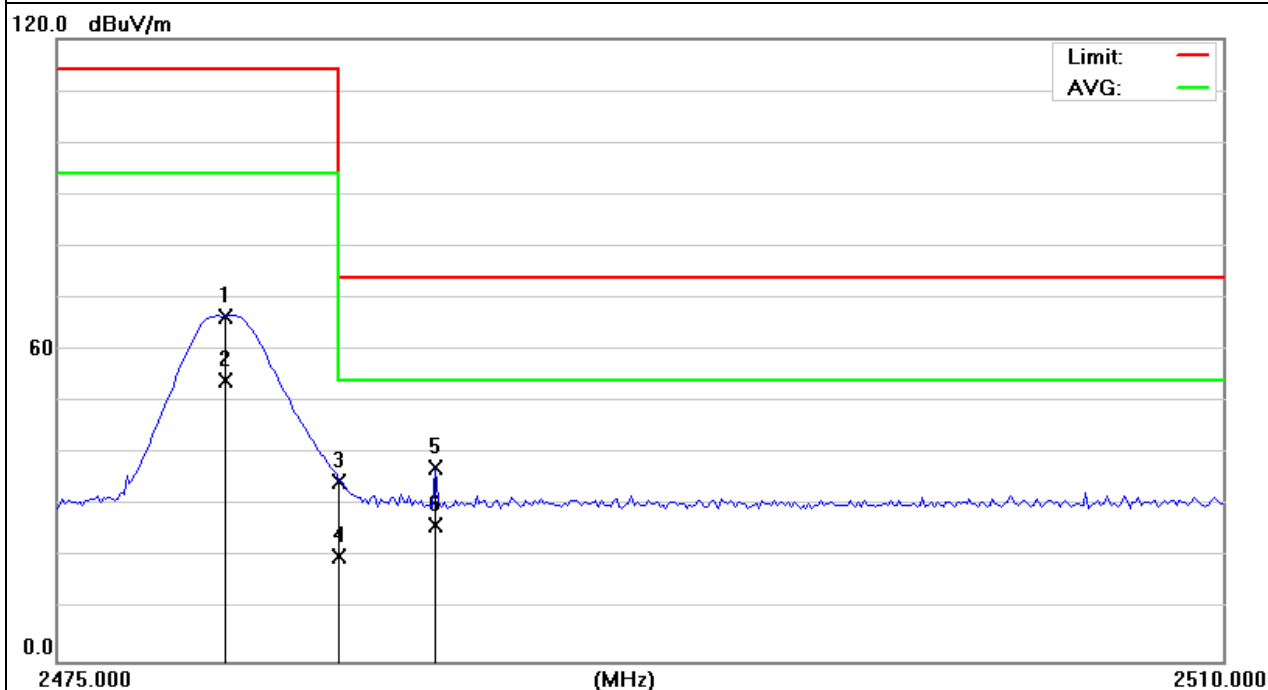

EUT :	Remote Controller	Model Name :	M3
Temperature :	25 °C	Relative Humidity :	55%
Pressure :	1010 hPa	Test Voltage :	DC 3.7V
Test Mode :	TX	Polarization :	Vertical

Frequency (MHz)	Meter Reading (dB $\mu$ V)	Factor (dB)	Emission Level (dB $\mu$ V/m)	Limits (dB $\mu$ V/m)	Margin (dB)	Detector Type
2480	90.82	-10.59	80.23	114.0 0	-33.77	peak
2480	79.95	-10.59	69.36	94	-24.64	AVG
2483.5	55.54	-10.63	44.91	74	-29.09	peak
2483.5	36.98	-10.63	26.35	54	-27.65	AVG

Remark:  
Factor = Antenna Factor + Cable Loss – Pre-amplifier.

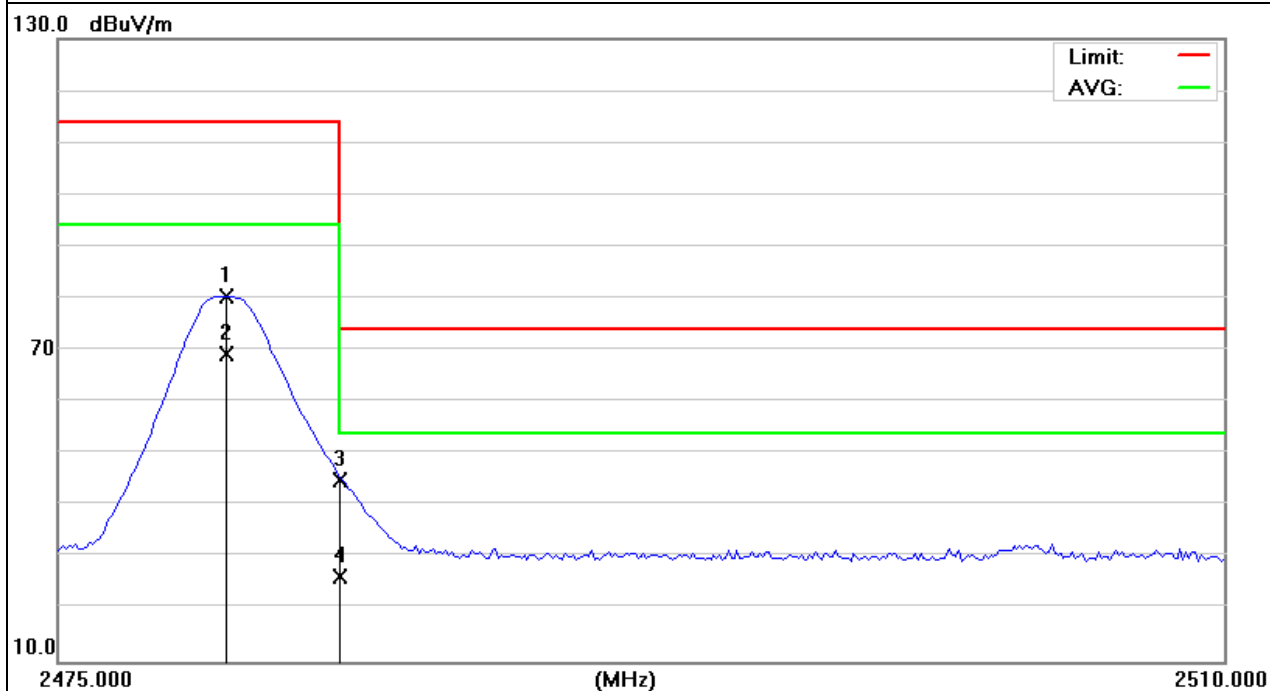

EUT :	Remote Controller	Model Name :	M3
Temperature :	25 °C	Relative Humidity :	55%
Pressure :	1010 hPa	Test Voltage :	DC 3.7V
Test Mode :	TX	Polarization :	Horizontal

Frequency (MHz)	Meter Reading (dB $\mu$ V)	Factor (dB)	Emission Level (dB $\mu$ V/m)	Limits (dB $\mu$ V/m)	Margin (dB)	Detector Type
2400	65.27	-9.82	55.45	74	-18.55	peak
2400	51.84	-9.82	42.02	54	-11.98	AVG
2402	83.45	-9.84	73.61	114.0 0	-40.39	peak
2402	63.53	-9.84	53.69	94	-40.31	AVG

Remark:  
Factor = Antenna Factor + Cable Loss – Pre-amplifier.

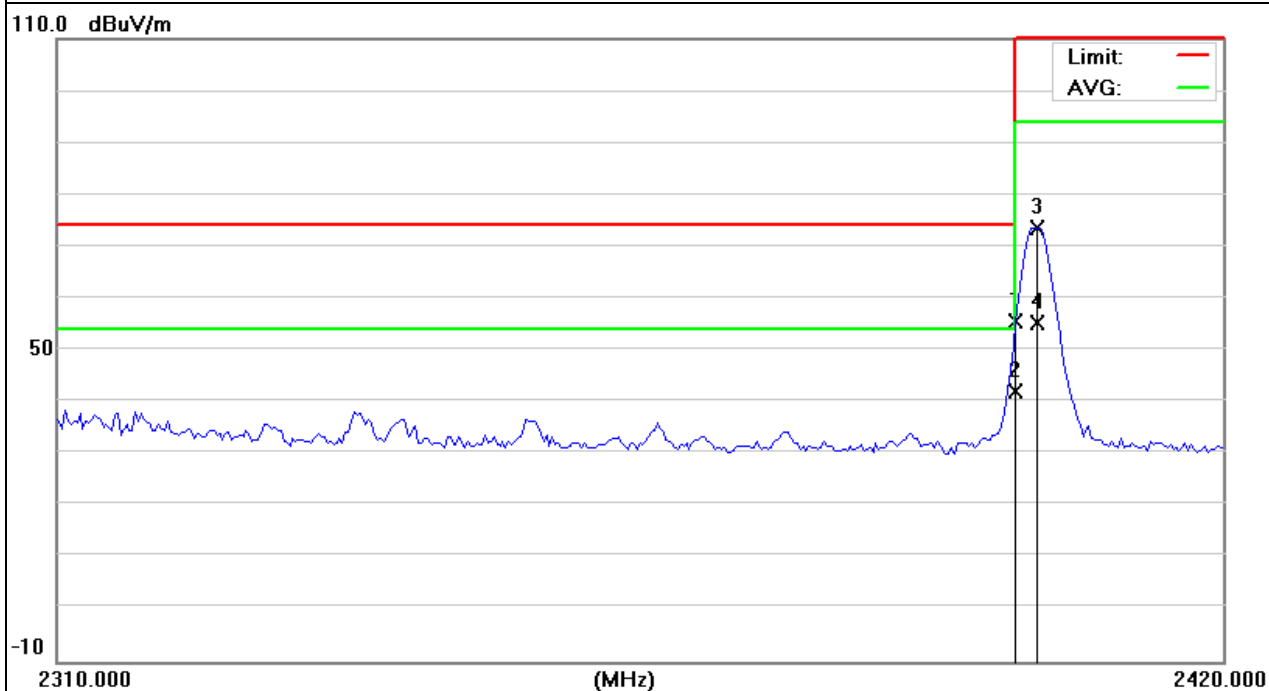

EUT :	Remote Controller	Model Name :	M3
Temperature :	25 °C	Relative Humidity :	55%
Pressure :	1010 hPa	Test Voltage :	DC 3.7V
Test Mode :	TX	Polarization :	Vertical

Frequency (MHz)	Meter Reading (dBμV)	Factor (dB)	Emission Level (dBμV/m)	Limits (dBμV/m)	Margin (dB)	Detector Type
2400	58.16	-9.82	48.34	74	-25.66	peak
2400	42.18	-9.82	32.36	54	-21.64	AVG
2402	79.04	-9.84	69.2	114.0 0	-44.8	peak
2402	65.09	-9.84	55.25	94	-38.75	AVG

Remark:  
 Factor = Antenna Factor + Cable Loss – Pre-amplifier.

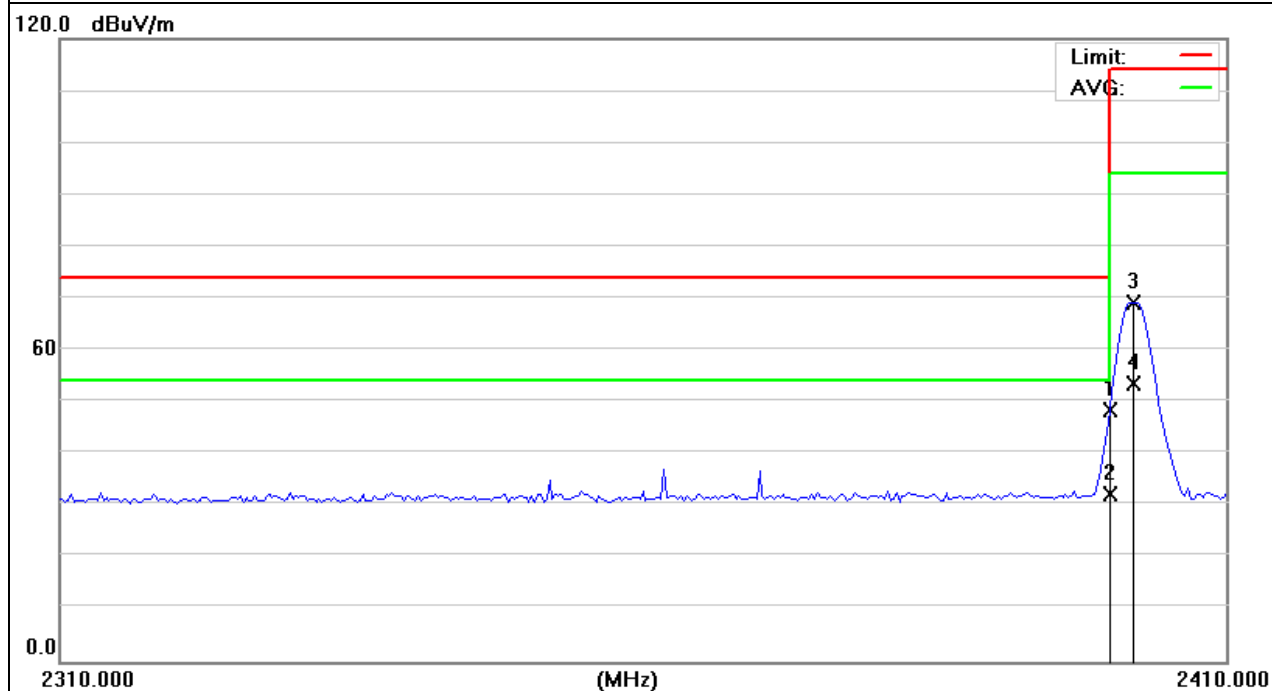

## 4. BANDWIDTH TEST

### 4.1 TEST PROCEDURE

- a. The EUT was directly connected to the spectrum analyzer and antenna output port as show in the block diagram below,
- b. Spectrum Setting : RBW= 100KHz, VBW  $\geq$  RBW, Sweep time = Auto.

### 4.2 DEVIATION FROM STANDARD

No deviation.

### 4.3 TEST SETUP



### 4.4 TEST RESULTS

EUT :	Remote Controller	Model Name :	M3
Temperature :	26 °C	Relative Humidity :	53%
Pressure :	1020 hPa	Test Power :	DC 3.7V
Test Mode :	Model 1/2/3		

Test Channel	Frequency (MHz)	20 dBc Bandwidth (MHz)
CH00	2402	1.266
CH08	2440	1.322
CH14	2480	1.259

#### 2402 MHz



### 2440 MHz

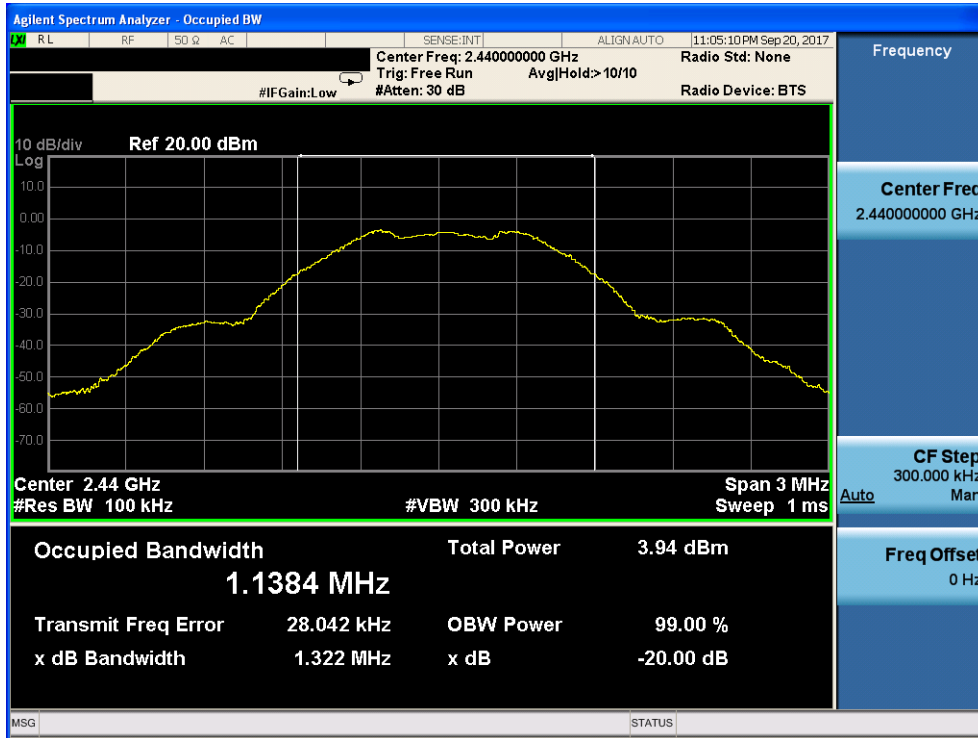

### 2480 MHz

