

# Datasheet

产品名称 (Product): BT 5.1 module

产品型号 (Model No.): Holyiot-22029-nrf52833

1. Description .....	3
Hardware : .....	3
Features : .....	3
Application: .....	5
2. Introduction .....	5
2.1 Programmer .....	6
2.2 Software development Tool.....	6
2.3 Protocols .....	6
Software Development Kit.....	6
2.4 SoftDevices .....	7
3. Product Descriptions .....	7
3.1 Mechanical drawings.....	8
3.2 Pin assignments.....	8
4. Mounting our board on the host PCBA.....	11
5. Miscellaneous.....	11
6. Absolute maximum ratings.....	12
7. FCC WARNING.....	13

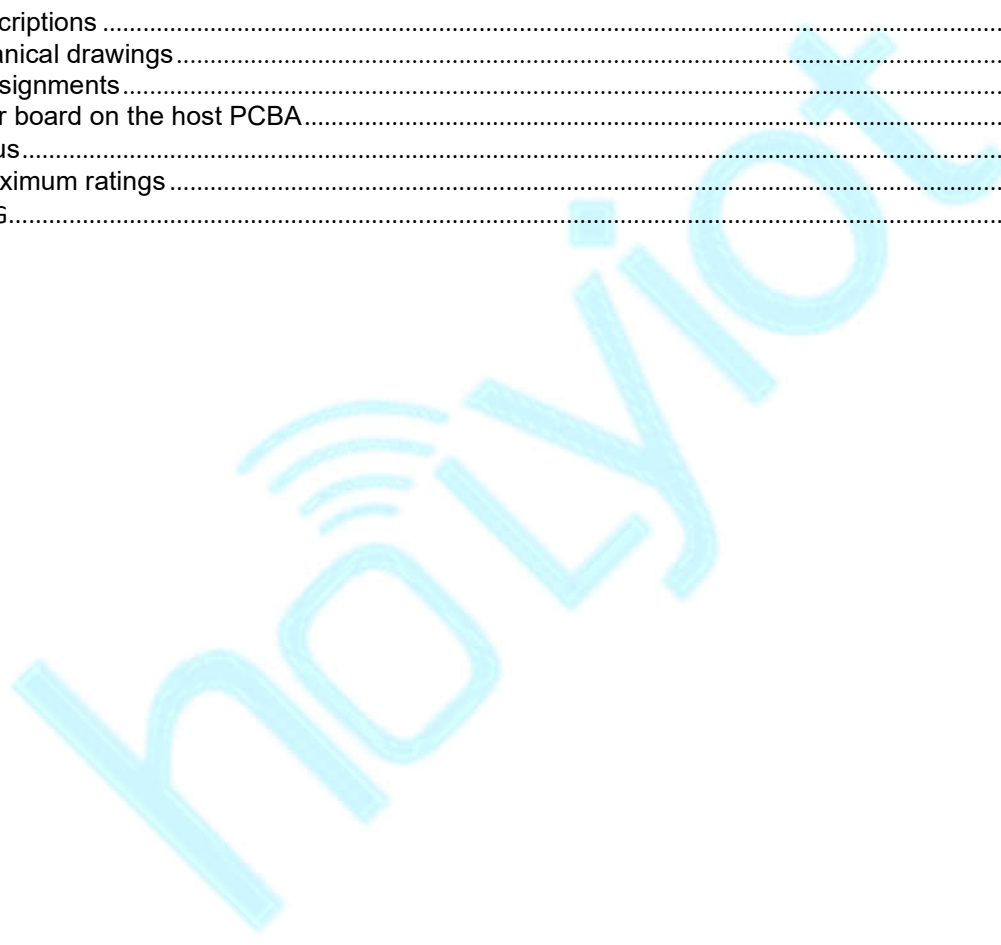

# 1. Description

HOLYIOT-22029 BLE 5.1 module is based on Nordic nRF52833 SoC, the nRF52833 SoC is a powerful, highly flexible ultra-low power multi-protocol SoC ideally suited for Bluetooth® low energy (previously called Bluetooth Smart), ANT and 2.4GHz ultra low-power wireless applications. The nRF52833 SoC is built around a 32-bit ARM® Cortex™-M4F CPU with FPU. Flash 512kB + 128kB RAM. Angle-of-arrival (AoA) and angle-of-departure (AoD), 128-bit AES/ECB/CCM/AAR co-processor . It offers a wealth of peripherals that include NFC, USB and multiple interface options

The embedded 2.4GHz transceiver supports Bluetooth low energy, ANT and proprietary 2.4 GHz protocol stack. It is on air compatible with the nRF51 Series, nRF24L and nRF24AP Series products from Nordic Semiconductor.

Multiprotocol radio (bluetooth low energy, ANT, 2.4G proprietary)

Bluetooth 5.1 long range

Processing power and flash flexibility

Multiprotocol radio

## Hardware :

SWD programmer (SWDIO, SWCLK, VDD, GND)

nRF52833 aQFN™73 package, 7 x 7 mm

Size : 19mm\*13.5mm

BLE stack & RF 2.4Ghz

## Features :

Bluetooth

®

5.1, IEEE 802.15.4-2006, 2.4 GHz transceiver

- -96 dBm sensitivity in 1 Mbps Bluetooth

®

low energy mode

- -103 dBm sensitivity in 125 kbps Bluetooth

®

low energy mode (long range)

- -20 to +8 dBm TX power, configurable in 4 dB steps
- On-air compatible with nRF52, nRF51, nRF24L, and nRF24AP Series
- Supported data rates:

- Bluetooth

®

- 5.1 – 2 Mbps, 1 Mbps, 500 kbps, and 125 kbps
- IEEE 802.15.4-2006 – 250 kbps
- Proprietary 2.4 GHz – 2 Mbps, 1 Mbps

• Angle-of-arrival (AoA) and angle-of-departure (AoD) direction finding using Bluetooth ®
--

- Single-ended antenna output (on-chip balun)
- 128-bit AES/ECB/CCM/AAR co-processor (on-the-fly packet encryption)
- 4.9 mA peak current in TX (0 dBm)
- 4.6 mA peak current in RX
- RSSI (1 dB resolution)
- ARM

®

Cortex

®

- M4 32-bit processor with FPU, 64 MHz
- 217 EEMBC CoreMark

®

score running from flash memory

- 52  $\mu$ A/MHz running CoreMark from flash memory
- 38  $\mu$ A/MHz running CoreMark from RAM
- Watchpoint and trace debug modules (DWT, ETM, and ITM)
- Serial wire debug (SWD)
- Rich set of security features
- Secure boot ready
- Flash access control list (ACL)
- Debug control and configuration
- Access port protection (CTRL-AP)
- Secure erase
- Flexible power management
- 1.7 V to 5.5 V supply voltage range
- On-chip DC/DC and LDO regulators with automated low current modes
- Automated peripheral power management
- Fast wake-up using 64 MHz internal oscillator
- 0.6  $\mu$ A at 3 V in System OFF mode, no RAM retention
- 1.5  $\mu$ A at 3 V in System ON mode, no RAM retention, wake on RTC
- 512 kB flash and 128 kB RAM
- Advanced on-chip interfaces
- USB 2.0 full speed (12 Mbps) controller
- High-speed 32 MHz SPI
- Type 2 near field communication (NFC-A) tag with wake-on field
- Touch-to-pair support
- Programmable peripheral interconnect (PPI)
- 42 general purpose I/O pins
- EasyDMA automated data transfer between memory and peripherals
- Nordic SoftDevice ready with support for concurrent multiprotocol
- 12-bit, 200 kbps ADC – 8 configurable channels with programmable gain

- 64 level comparator
- 15 level low-power comparator with wake-up from System OFF mode
- Temperature sensor
- 4x four channel pulse width modulator (PWM) unit with EasyDMA
- Audio peripherals – I2S, digital microphone interface (PDM)
- 5x 32-bit timer with counter mode
- Up to 4x SPI master/3x SPI slave with EasyDMA
- Up to 2x I2C compatible two-wire master/slave
- 2x UART (CTS/RTS) with EasyDMA
- Quadrature decoder (QDEC)
- 3x real-time counter (RTC)
- Single crystal operation

### **Application:**

- Advanced computer peripherals and I/O devices
- Mouse
- Keyboard
- Multi-touch trackpad
- Advanced wearables
- Health/fitness sensor and monitor devices
- Wireless payment enabled devices
- Internet of things (IoT)
- Smart home sensors and controllers
- Industrial IoT sensors and controllers
- Interactive entertainment devices
- Remote controls
- Gaming controllers

## **2. Introduction**

### **2.1 Programmer**

HOLYIOT-22029 module use the Serial Wire Debug(SWD port ), the module which layout the SWDIO, SWCLK, VDD, GND for debug and flash your own firmware, more info about the SWD, please visit [https://www.silabs.com/community/mcu/32-bit/knowledge-base.entry.html/2014/10/21/serial\\_wire\\_debugs-qKCT](https://www.silabs.com/community/mcu/32-bit/knowledge-base.entry.html/2014/10/21/serial_wire_debugs-qKCT)

You can using the Jlink or Jtag for programmer.

## 2.2 Software development Tool

It supports the standard Nordic Software Development Tool-chain using Segger Embedded Studio, Keil, IAR and GCC. More info please visit

<https://www.nordicsemi.com/Software-and-Tools/Development-Tools>

## 2.3 Protocols

This module support Bluetooth®5.1, IEEE 802.15.4-2006, 2.4 GHz transceiver, 2.4GHz proprietary. So we can use different protocols for different situations.

### **Software Development Kit**

Nordic Semiconductor's Software Development Kits (SDK) are your starting point for software development on the nRF51 and nRF52 Series. It contains source code libraries and example applications covering wireless functions, libraries for all peripherals, bootloaders, wired and OTA FW upgrades, RTOS examples, serialization libraries.

More info please visit <https://www.nordicsemi.com/Software-and-Tools/Software/nRF5-SDK>

You can also download the SDK for coding development .

## 2.4 SoftDevices

Nordic Semiconductor protocol stacks are known as SoftDevices. SoftDevices are pre-compiled, pre-linked binary files. SoftDevices can be programmed in nRF5 series devices, and are freely downloadable from the Nordic website. Please download that here: <https://www.nordicsemi.com/Software-and-Tools/Software/S132>

### Over-The-Air DFU

The SoC is supported by an Over-The-Air Device Firmware Upgrade (OTA DFU) feature. This allows for in the field updates of application software and SoftDevice.

## 3. Product Descriptions

### 3.1 Mechanical drawings

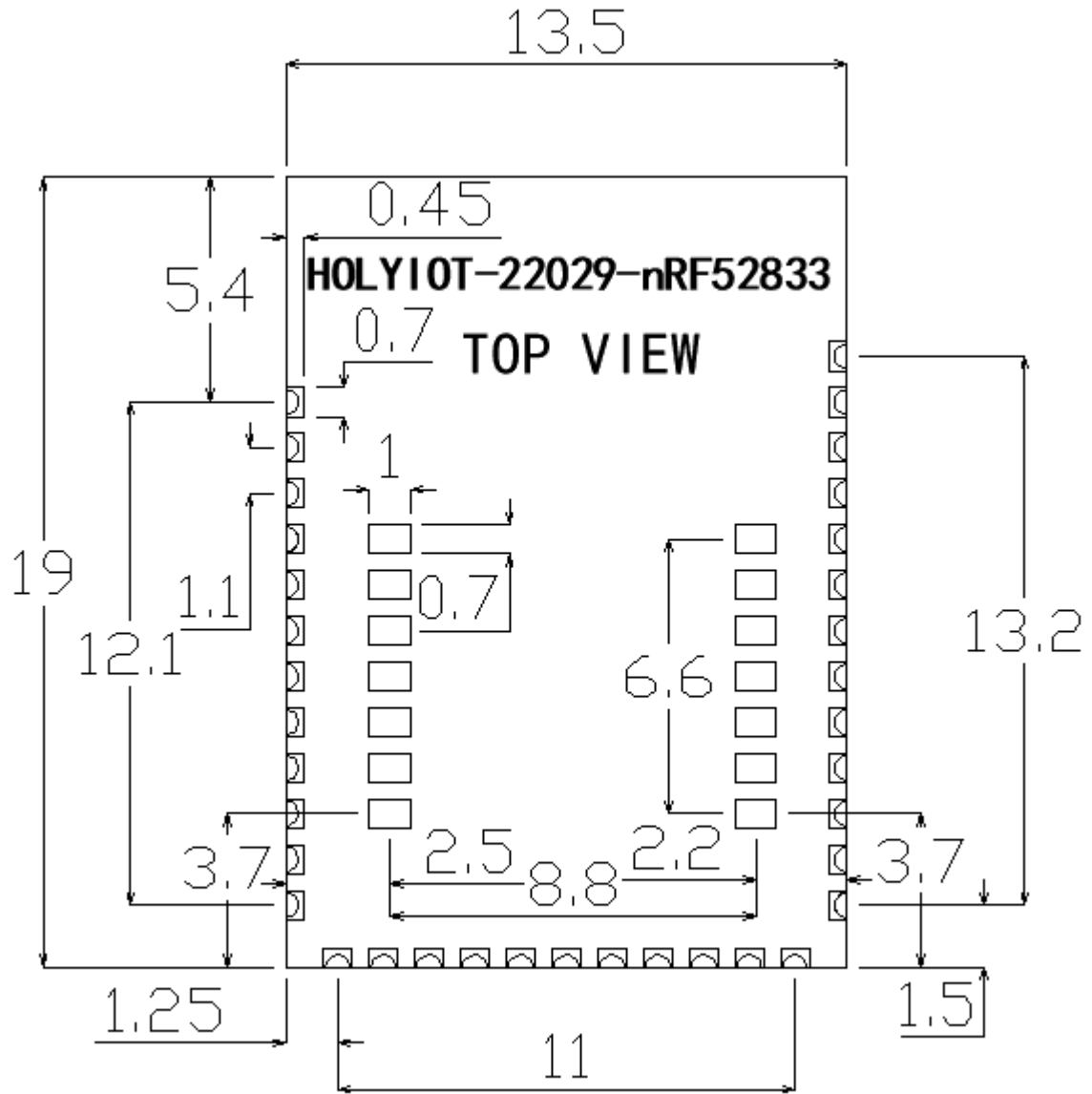

### 3.2 Pin assignments

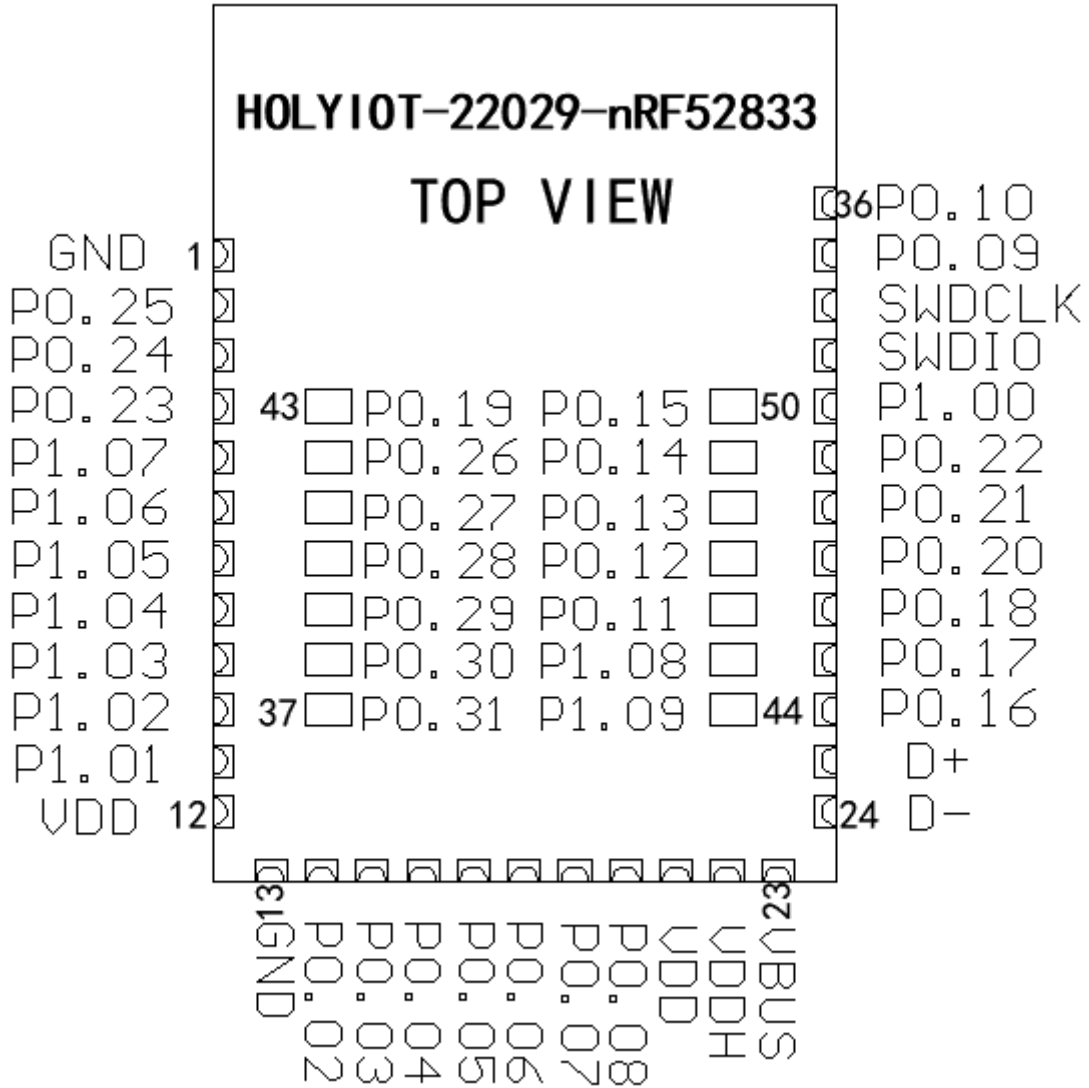

PIN No.	PIN define	Functions
1	GND	Ground
2	P0.25	Digital I/O(general purpose I/O)
3	P0.24	Digital I/O(general purpose I/O)
4	P0.23	Digital I/O(general purpose I/O)
5	P1.07	Digital I/O(general purpose I/O)
6	P1.06	Digital I/O(general purpose I/O)
7	P1.05	Digital I/O(general purpose I/O)
8	P1.04	Digital I/O(general purpose I/O)
9	P1.03	Digital I/O(general purpose I/O)
10	P1.02	Digital I/O(general purpose I/O)
11	P1.01	Digital I/O(general purpose I/O)
12	VDD	Power



13	GND	Ground
14	P0.02 (AIN0)	Digital I/O(general purpose I/O <sup>2</sup> ) Analog input
15	P0.03 (AIN1)	Digital I/O(general purpose I/O <sup>2</sup> ) Analog input
16	P0.04 (AIN2)	Digital I/O(general purpose I/O <sup>2</sup> ) Analog input
17	P0.05 (AIN3)	Digital I/O(general purpose I/O <sup>2</sup> ) Analog input
18	P0.06	Digital I/O(general purpose I/O)
19	P0.07 TRACECLK	Digital I/O(general purpose I/O) Trace clock
20	P0.08	Digital I/O(general purpose I/O)
21	VDD	Power
22	VDDH	Power High voltage power supply
23	VBUS	Power 5 V input for USB 3.3 V regulator
24	D-	USB D-
25	D+	USB D+
26	P0.16	Digital I/O(general purpose I/O)
27	P0.17	Digital I/O(general purpose I/O)
28	P0.18 nRESET	Digital I/O(general purpose I/O) Configurable as pin RESET
29	P0.20	Digital I/O(general purpose I/O)
30	P0.21	Digital I/O(general purpose I/O)
31	P0.22	Digital I/O(general purpose I/O)
32	P1.00 TRACEDATA0	Digital I/O(general purpose I/O) Trace buffer TRACEDATA[0]
33	SWDIO	Debug Serial wire debug I/O for debug and programming
34	SWDCLK	Debug Serial wire debug clock input for debug and programming
35	P0.09 NFC1	Digital I/O(general purpose I/O <sup>1</sup> ) NFC1 input(antenna connection)
36	P0.10	Digital I/O(general purpose I/O <sup>1</sup> )

	NFC2	NFC2 input(antenna connection)
37	P0.31 (AIN7)	Digital I/O(general purpose I/O <sup>2</sup> ) Analog input
38	P0.30 (AIN6)	Digital I/O(general purpose I/O <sup>2</sup> ) Analog input
39	P0.29 (AIN5)	Digital I/O(general purpose I/O <sup>2</sup> ) Analog input
40	P0.28 (AIN4)	Digital I/O(general purpose I/O <sup>2</sup> ) Analog input
41	P0.27	Digital I/O(general purpose I/O)
42	P0.26	Digital I/O(general purpose I/O)
43	P0.19	Digital I/O(general purpose I/O)
44	P1.09 TRACEDATA3	Digital I/O(general purpose I/O) Trace buffer TRACEDATA[3]
45	P1.08	Digital I/O(general purpose I/O)
46	P0.11 TRACEDATA2	Digital I/O(general purpose I/O) Trace buffer TRACEDATA[2]
47	P0.12 TRACEDATA1	Digital I/O(general purpose I/O) Trace buffer TRACEDATA[1]
48	P0.13	Digital I/O(general purpose I/O)
49	P0.14	Digital I/O(general purpose I/O)
50	P0.15	Digital I/O(general purpose I/O)

## 4. Mounting our board on the host PCBA

We suggest that you mount our RF board(HOLYIOT-22029 -nRF52833) on the board like that:

1. For the best Bluetooth performance, the antenna of the area need to extend about several mm without ground under the antenna of the edge of the host PCB.

2. The second choice is that place our board at the corner of host PCB, the antenna of board need to extend several mm outside of the Ground plane of the host PCB.

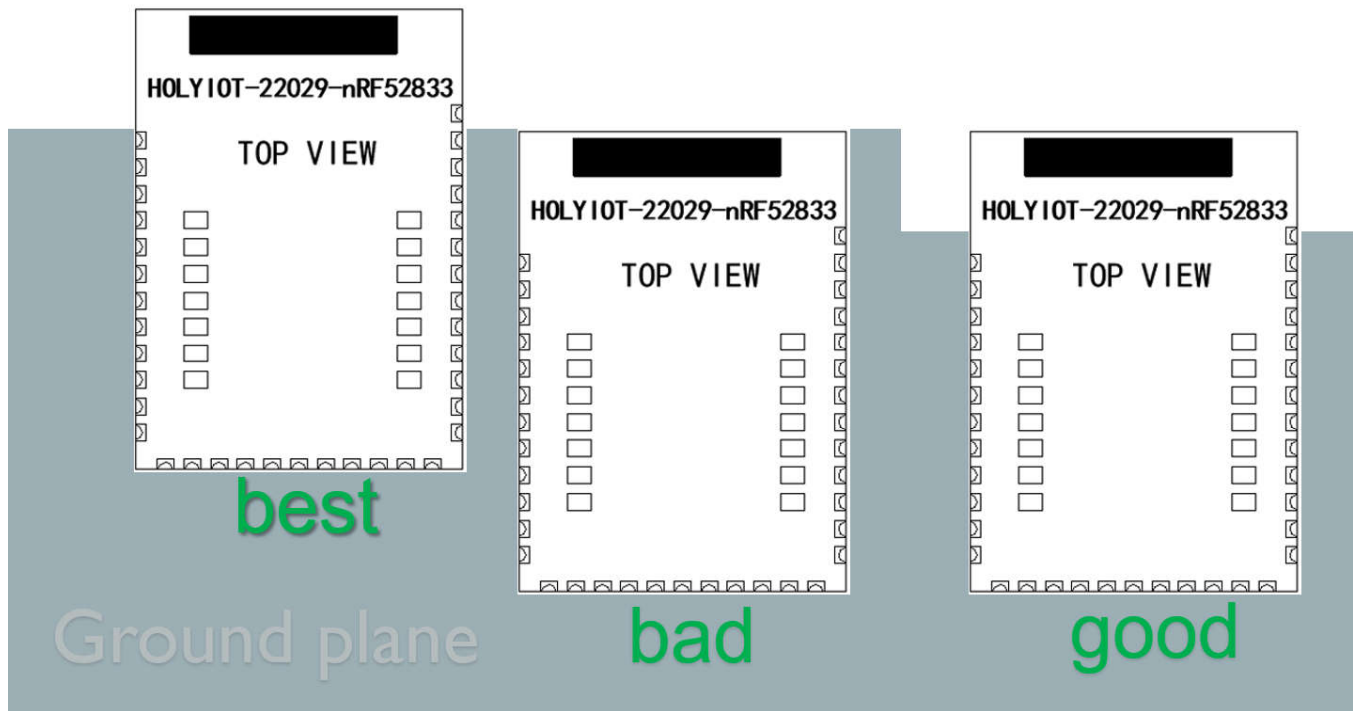

## 5. Miscellaneous

Soldering Temperature-Time Profile for Re-Flow Soldering. Maximum number of cycles for re-flow is 2. No opposite side re-flow is allowed due to module weight.

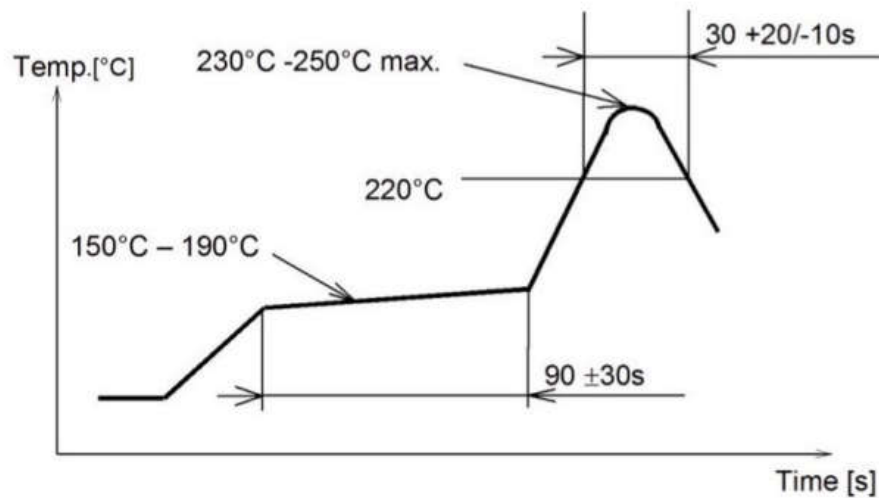

## 6. Absolute maximum ratings

Maximum ratings are the extreme limits to which the chip can be exposed for a limited amount of time without permanently damaging it. Exposure to absolute maximum ratings for prolonged periods of time may affect the reliability of the device.

Absolute maximum ratings:

	Note	Min.	Max.	Unit
<b>Supply voltages</b>				
VDD		-0.3	+3.9	V
VDDH		-0.3	+5.8	V
VBUS		-0.3	+5.8	V
VSS			0	V
<b>I/O pin voltage</b>				
$V_{I/O}$ , VDD $\leq$ 3.6 V		-0.3	VDD + 0.3	V
$V_{I/O}$ , VDD $>$ 3.6 V		-0.3	3.9	V
<b>NFC antenna pin current</b>				
$I_{NFC1/2}$			80	mA
<b>Environmental aQFN™ package</b>				
Storage temperature		-40	+125	°C
MSL	Moisture Sensitivity Level		2	
ESD HBM	Human Body Model		4	kV
ESD HBM Class	Human Body Model Class		3A	
ESD CDM	Charged Device Model		750	V
<b>Environmental QFN40 package</b>				
Storage temperature		-40	+125	°C
MSL	Moisture Sensitivity Level		2	
ESD HBM	Human Body Model		4	kV
ESD HBM Class	Human Body Model Class		3A	
ESD CDM	Charged Device Model		1	kV
<b>Environmental WLCSP 3.175 x 3.175 mm package</b>				
Storage temperature		-40	+125	°C
MSL	Moisture Sensitivity Level		1	
ESD HBM	Human Body Model		4	kV
ESD HBM Class	Human Body Model Class		3A	
ESD CDM	Charged Device Model		750	V
<b>Flash memory</b>				
Endurance		10 000		write/erase cycles
Retention at 85 °C		10		years
Retention at 105 °C	Limited to 1000 write/erase cycles	3		years
Retention at 105 °C-85 °C, execution split	Limited to 1000 write/erase cycles	6.7		years



## 7.FCC WARNING

FCC Caution: Any changes or modifications not expressly approved by the party responsible for compliance could void the user's authority to operate this equipment.

This device complies with Part 15 of the FCC Rules.

Operation is subject to the following two conditions: (1) This device may not cause harmful interference, and (2) this device must accept any interference received, including interference that may cause undesired operation.

This device and its antenna(s) must not be co-located or operating in conjunction with any other antenna or transmitter.

15.105 Information to the user.

(b) For a Class B digital device or peripheral, the instructions furnished the user shall include the following or similar statement, placed in a prominent location in the text of the manual:

Note: This equipment has been tested and found to comply with the limits for a Class B digital device, pursuant to part 15 of the FCC Rules. These limits are designed to provide reasonable protection against harmful

interference in a residential installation. This equipment generates, uses and can radiate radio frequency energy and, if not installed and used in accordance with the instructions, may cause harmful interference to radio communications. However, there is no guarantee that interference will not occur in a particular installation. If this equipment does cause harmful interference to radio or television reception, which can be determined by turning the equipment off and on, the user is encouraged to try to correct the interference by one or more of the following measures:

- Reorient or relocate the receiving antenna.
- Increase the separation between the equipment and receiver.
- Connect the equipment into an outlet on a circuit different from that to which the receiver is connected.
- Consult the dealer or an experienced radio/TV technician for help.

This equipment complies with FCC radiation exposure limits set forth for an uncontrolled environment. This equipment should be installed and operated with minimum distance 20

cm between the radiator and your body.

Radiation Exposure Statement:

This equipment complies with FCC radiation exposure limits set forth for an uncontrolled environment.

This transmitter must not be co-located or operating in conjunction with any other

antenna or transmitter.

The availability of some specific channels and/or operational frequency bands are country dependent and are firmware programmed at the factory to match the intended destination.

The firmware setting is not accessible by the end user.

The final end product must be labelled in a visible area with the following:

“Contains Transmitter Module “2ALGY-22029 ”





## Requirement per KDB996369 D03

### 2.2 List of applicable FCC rules

List the FCC rules that are applicable to the modular transmitter. These are the rules that specifically establish the bands of operation, the power, spurious emissions, and operating fundamental frequencies. DO NOT list compliance to unintentional-radiator rules (Part 15 Subpart B) since that is not a condition of a module grant that is extended to a host manufacturer. See also Section

2.10 below concerning the need to notify host manufacturers that further testing is required.3

**Explanation:** This module meets the requirements of FCC part 15C (15.247).it Specifically identified AC Power Line Conducted Emission, Radiated Spurious emissions, Band edge and RF Conducted Spurious Emissions, Conducted Peak Output Power, Bandwidth, Power Spectral Density, Antenna Requirement.

#### 2.3 Summarize the specific operational use conditions

Describe use conditions that are applicable to the modular transmitter, including for example any limits on antennas, etc. For example, if point-to-point antennas are used that require reduction in power or compensation for cable loss, then this information must be in the instructions. If the use condition limitations extend to professional users, then instructions must state that this information also extends to the host manufacturer's instruction manual. In addition, certain information may also be needed, such as peak gain per frequency band and minimum gain, specifically for master devices in 5 GHz DFS bands.

**Explanation:** The product antenna uses an irreplaceable antenna with a gain of 1dBi

#### 2.4 Single Modular

If a modular transmitter is approved as a "Single Modular ," then the module manufacturer is responsible for approving the host environment that the Single Modular is used with. The manufacturer of a Single Modular must describe, both in the filing and in the installation instructions, the alternative means that the Single Modular manufacturer uses to verify that the host meets the necessary requirements to satisfy the module limiting conditions.

A Single Modular manufacturer has the flexibility to define its alternative method to address the conditions that limit the initial approval, such as: shielding, minimum signaling amplitude, buffered modulation/data inputs, or power supply regulation. The alternative method could include that the limited



module manufacturer reviews detailed test data or host designs prior to giving the host manufacturer approval.

This Single Modular procedure is also applicable for RF exposure evaluation when it is necessary to demonstrate compliance in a specific host. The module manufacturer must state how control of the product into which the modular transmitter will be installed will be maintained such that full compliance of the product is always ensured. For additional hosts other than the specific host originally granted with a limited module, a Class II permissive change is required on the module grant to register the additional host as a specific host also approved with the module.

**Explanation:** The module is a single module.

#### 2.5 Trace antenna designs

For a modular transmitter with trace antenna designs, see the guidance in Question 11 of KDB Publication 996369 D02 FAQ – Modules for Micro-Strip Antennas and traces. The integration information shall include for the TCB review the integration instructions for the following aspects: layout of trace design, parts list (BOM), antenna, connectors, and isolation requirements.

- a) Information that includes permitted variances (e.g., trace boundary limits, thickness, length, width, shape(s), dielectric constant, and impedance as applicable for each type of antenna);
- b) Each design shall be considered a different type (e.g., antenna length in multiple(s) of frequency, the wavelength, and antenna shape (traces in phase) can affect antenna gain and must be considered);
- c) The parameters shall be provided in a manner permitting host manufacturers to design the printed circuit (PC) board layout;
- d) Appropriate parts by manufacturer and specifications;
- e) Test procedures for design verification; and
- f)

Production test procedures for ensuring compliance

The module grantee shall provide a notice that any deviation(s) from the defined parameters of the antenna trace, as described by the instructions, require that the host product manufacturer must notify the module grantee that they wish to change the antenna trace design. In this case, a Class II permissive change application is required to be filed by the grantee, or the host manufacturer can take responsibility through the change in FCC ID (new application) procedure followed by a Class II permissive change application

## 2.6 RF exposure considerations

It is essential for module grantees to clearly and explicitly state the RF exposure conditions that permit a host product manufacturer to use the module. Two types of instructions are required for RF exposure information: (1) to the host product manufacturer, to define the application conditions

(mobile, portable – xx cm from a person's body); and (2) additional text needed for the host product manufacturer to provide to end users in their end-product manuals. If RF exposure statements and use conditions are not provided, then the host product manufacturer is required to take responsibility of the module through a change in FCC ID (new application).

**Explanation:** The module complies with FCC radiofrequency radiation exposure limits for uncontrolled environments. The device is installed and operated with a distance of more than 20 cm between the radiator and your body." This module follows FCC statement design, FCC ID :2ALGY-22029

## 2.7 Antennas

A list of antennas included in the application for certification must be provided in the instructions. For modular transmitters approved as limited modules, all applicable professional installer instructions must be included as part of the information to the host product manufacturer. The antenna list shall also identify the antenna types (monopole, PIFA, dipole, etc. (note that for example an "omni-directional antenna" is not considered to be a specific "antenna type").

For situations where the host product manufacturer is responsible for an external connector, for example with an RF pin and antenna trace design, the integration instructions shall inform the installer that unique antenna connector must be used on the Part 15 authorized transmitters used in the host product.

The module manufacturers shall provide a list of acceptable unique connectors.

**Explanation:** The product antenna uses an irreplaceable antenna with a gain of  
-1.45dBi

## 2.8 Label and compliance information

Grantees are responsible for the continued compliance of their modules to the FCC rules. This

includes advising host product manufacturers that they need to provide a physical or e-label stating “Contains FCC ID” with their finished product. See Guidelines for Labeling and User Information for RF Devices – KDB Publication 784748.

**Explanation:** The host system using this module, should have label in a visible area indicated the following texts: "Contains  
FCC ID: **2ALGY-22029**

**2.9 Information on test modes and additional testing requirements** Additional guidance for testing host products is given in KDB Publication 996369 D04 Module Integration Guide. Test modes should take into consideration different operational conditions for a stand-alone modular transmitter in a host, as well as for multiple simultaneously transmitting modules or other transmitters in a host product.

The grantee should provide information on how to configure test modes for host product evaluation for different operational conditions for a stand-alone modular transmitter in a host, versus with multiple, simultaneously transmitting modules or other transmitters in a host.

Grantees can increase the utility of their modular transmitters by providing special means, modes, or instructions that simulates or characterizes a connection by enabling a transmitter. This can greatly simplify a host manufacturer’s determination that a module as installed in a host complies with FCC requirements.

**Explanation:** Ningde linyang Electronic Technology Co., Ltd. can increase the utility of our modular transmitters by providing instructions that simulates or characterizes a connection by enabling a transmitter.

## 2.10 Additional testing, Part 15 Subpart B disclaimer

The grantee should include a statement that the modular transmitter is only FCC authorized for the specific rule parts (i.e., FCC transmitter rules) listed on the grant, and that the host product manufacturer is responsible for compliance to any other FCC rules that apply to the host not covered by the

modular transmitter grant of certification. If the grantee markets their product



as being Part 15

Subpart B compliant (when it also contains unintentional-radiator digital circuitry), then the grantee shall provide a notice stating that the final host product still requires Part 15

Subpart B compliance testing with the modular transmitter installed.

**Explanation:** The module without unintentional-radiator digital circuitry, so the module does not require an evaluation by FCC Part 15 Subpart B. The host should be evaluated by the FCC Subpart B.

