



## FCC TEST REPORT

**FCC ID: 2ALGN-JH-TX507**

On Behalf of

Quanzhou Juhui Electronics Co., Ltd

Remote control

Model No.: JH-TX507

Prepared for : Quanzhou Juhui Electronics Co., Ltd  
Address : No288, Changxing Road, Huoju Industrial District, Licheng Area,  
Quanzhou, Fujian, China

Prepared By : Shenzhen Alpha Product Testing Co., Ltd.  
Address : Building i, No.2, Lixin Road, Fuyong Street, Bao'an District, 518103,  
Shenzhen, Guangdong, China

Report Number : A2409173-C02-R01  
Date of Receipt : September 20, 2024  
Date of Test : September 20, 2024- November 8, 2024  
Date of Report : November 8, 2024  
Version Number : V0  
**Test Result : Pass**

## Contents

<b>1. General Information .....</b>	<b>5</b>
1.1. Description of Device (EUT) .....	5
1.2. Accessories of Device (EUT).....	6
1.3. Tested Supporting System Details.....	6
1.4. Test Facility .....	6
<b>2. Summary of Test.....</b>	<b>7</b>
2.1. Summary of Test Result .....	7
2.2. Block Diagram.....	7
2.3. Test Mode .....	8
2.4. Test Conditions .....	8
2.5. Measurement Uncertainty (95% confidence levels, k=2).....	8
2.6. Test Equipment .....	9
<b>3. Radiation Emission .....</b>	<b>11</b>
3.1. Radiation Emission Limits(15.209&231).....	11
3.2. Test Setup.....	11
3.3. Test Procedure.....	12
3.4. Test Equipment Setting For emission test.....	12
3.5. Test Condition .....	13
3.6. Test Result.....	13
<b>4. Power Line Conducted Emission .....</b>	<b>19</b>
4.1. Conducted Emission Limits (15.209).....	19
4.2. Test Setup.....	19
4.3. Test Procedure.....	19
4.4. Test Results .....	20
<b>5. Occupied bandwidth .....</b>	<b>21</b>
5.1. Test Limit.....	21
5.2. Method of Measurement .....	21
5.3. Test Setup.....	21
5.4. Test Results .....	21
<b>6. Transmission Time.....</b>	<b>23</b>
6.1. Test Limit.....	23
6.2. Method of Measurement .....	23
6.3. Test Setup.....	23
6.4. Test Results .....	23
<b>7. Antenna Requirement.....</b>	<b>25</b>
7.1. Standard Requirement.....	25
7.2. Antenna Connected Construction.....	25
7.3. Result .....	25
<b>8. Test Setup Photo.....</b>	<b>26</b>

TEST REPORT DECLARATION

Applicant : Quanzhou Juhui Electronics Co., Ltd  
 Address : No288, Changxing Road, Huoju Industrial District, Licheng Area, Quanzhou, Fujian, China  
 Manufacturer : Quanzhou Juhui Electronics Co., Ltd  
 Address : No288, Changxing Road, Huoju Industrial District, Licheng Area, Quanzhou, Fujian, China  
 EUT Description : Remote control  
 (A) Model No. : JH-TX507  
 (B) Trademark : /

Measurement Standard Used:

**FCC Rules and Regulations Part 15 Subpart C Section 15.231**  
**ANSI C63.10-2013**

The device described above is tested by Shenzhen Alpha Product Testing Co., Ltd. to determine the maximum emission levels emanating from the device. The maximum emission levels are compared to the FCC Part 15 Subpart C limits both conducted and radiated emissions. The test results are contained in this test report and Shenzhen Alpha Product Testing Co., Ltd. is assumed of full responsibility for the accuracy and completeness of these tests.

After the test, our opinion is that EUT compliance with the requirement of the above standards.

This report applies to above tested sample only. This report shall not be reproduced in parts without written approval of Shenzhen Alpha Product Testing Co., Ltd.

Tested by (name + signature).....: Yannis Wen  
Project Engineer

*Yannis Wen*  
-----

Approved by (name + signature).....: Jack Xu  
Project Manager

*Jack Xu*  
-----

Date of issue.....: November 8, 2024

**Revision History**

Revision	Issue Date	Revisions	Revised By
V0	November 8, 2024	Initial released Issue	Yannis Wen

## 1. General Information

### 1.1. Description of Device (EUT)

EUT : Remote control  
Model No. : JH-TX507  
DIFF. : N/A  
Power supply : DC 6V by button cell.

Operation frequency : 300MHz

Number of channel : One channel

Modulation : FSK

Antenna Type : Internal Antenna, Maximum Gain is 0dBi

Software version : V1.0

Hardware version : V1.0

Intend use : Residential, commercial and light industrial environment  
environment

## 1.2. Accessories of Device (EUT)

Accessories1 : /  
Manufacturer : /  
Model : /  
Power supply : /

## 1.3. Tested Supporting System Details

No.	Description	Manufacturer	Model	Serial Number	Certification
/	/	/	/	/	/

## 1.4. Test Facility

Shenzhen Alpha Product Testing Co., Ltd  
Building i, No.2, Lixin Road, Fuyong Street, Bao'an District, 518103,  
Shenzhen, Guangdong, China

June 21, 2018 File on Federal Communication Commission

Registration Number: 293961

July 15, 2019 Certificated by IC

Registration Number: CN0085

## 2. Summary of Test

### 2.1. Summary of Test Result

Description of Test Item	Standard	Results
Spurious Emission	Section 15.231&15.209	PASS
Conduction Emission	Section 15.207	N/A
Occupied bandwidth	Section 15.231	PASS
Transmission time	Section 15.231	PASS
Band Edge	Section 15.231	N/A
Antenna Requirement	Section 15.203	PASS
Note : Test according to ANSI C63.10-2013		

### 2.2. Block Diagram

1. For radiated emissions test: EUT was placed on a turn table, which is 0.8 meters high above ground for below 1 GHz test and 1.5 meters high above ground for below 1 GHz test . EUT was set into test mode before test. New battery is used during all test

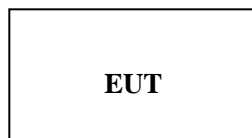

### 2.3. Test Mode

EUT work in Continuous TX mode, and select test channel, wireless mode

Tested mode, channel, and data rate information		
Mode	Channel	Frequency (MHz)
FSK	CH1	300MHz

### 2.4. Test Conditions

Temperature range	21-25°C
Humidity range	40-75%
Pressure range	86-106kPa

### 2.5. Measurement Uncertainty (95% confidence levels, k=2)

Item	Uncertainty
Uncertainty for Power point Conducted Emissions Test	1.63dB
Uncertainty for Radiation Emission test in 3m chamber (below 30MHz)	3.5dB
Uncertainty for Radiation Emission test in 3m chamber (30MHz to 1GHz)	3.74dB(Polarize: V)
	3.76dB(Polarize: H)
Uncertainty for Radiation Emission test in 3m chamber (1GHz to 25GHz)	3.77dB(Polarize: V)
	3.80dB(Polarize: H)
Uncertainty for Radiation Emission test in 3m chamber (18GHz to 40GHz)	4.31 dB(Polarize: V)
	4.30 dB(Polarize: H)
Uncertainty for radio frequency	$5.06 \times 10^{-8}$ GHz
Uncertainty for conducted RF Power	0.40dB
Uncertainty for temperature	0.2°C
Uncertainty for humidity	1%
Uncertainty for DC and low frequency voltages	0.06%



## 2.6. Test Equipment

Equipment	Manufacture	Model No.	Firmware version	Serial No.	Last cal.	Cal Interval
9*6*6 anechoic chamber	CHENYU	9*6*6	/	N/A	2022.05.18	3Year
Spectrum analyzer	ROHDE&SCHWARZ	FSV40-N	2.3	102137	2024.08.08	1Year
Spectrum analyzer	Agilent	N9020A	A.14.16	MY499100060	2024.08.08	1Year
Receiver	ROHDE&SCHWARZ	ESR	2.28 SP1	1316.3003K03-10 2082-Wa	2024.08.08	1Year
Receiver	R&S	ESCI	4.42 SP1	101165	2024.08.08	1Year
Bilog Antenna	Schwarzbeck	VULB 9168	/	VULB 9168#627	2023.08.28	2Year
Horn Antenna	SCHWARZBECK	BBHA 9120 D	/	2106	2023.08.19	2Year
Loop Antenna	SCHWARZBECK	FMZB 1519B	/	00128	2023.08.19	2Year
RF Cable	Resenberger	Cable 1	/	RE1	2024.08.08	1Year
RF Cable	Resenberger	Cable 2	/	RE2	2024.08.08	1Year
RF Cable	Resenberger	Cable 3	/	CE1	2024.08.08	1Year
Pre-amplifier	HP	HP8347A	/	2834A00455	2024.08.08	1Year
Pre-amplifier	Agilent	8449B	/	3008A02664	2024.08.08	1Year
L.I.S.N.#1	Schwarzbeck	NSLK8126	/	8126-466	2024.08.08	1Year
L.I.S.N.#2	ROHDE&SCHWARZ	ENV216	/	101043	2024.08.08	1Year
Horn Antenna	SCHWARZBECK	BBHA 9170	/	00946	2023.08.19	2Year
Preamplifier	SKET	LNPA_1840 -50	/	SK2018101801	2024.08.08	1 Year
Power Meter	Agilent	E9300A	/	MY41496628	2024.08.08	1 Year
Power Sensor	DARE	RPR3006W	/	15100041SNO91	2024.08.08	1 Year
Electronic Thermo-Hygrometer	S.H.Qixiang	HTC-1	/	N/A	2024.08.11	1 Year
Switching Mode Power Supply	JUNKE	JK12010S	/	20140927-6	2024.08.08	1 Year
Adjustable attenuator	MWRFtest	N/A	/	N/A	N/A	N/A
10dB Attenuator	Mini-Circuits	DC-6G	/	N/A	N/A	N/A

---

<b>Software Information</b>			
Test Item	Software Name	Manufacturer	Version
RE	EZ-EMC	Farad	Alpha-3A1
CE	EZ-EMC	Farad	Alpha-3A1
RF-CE	MTS 8310	MWRFtest	V2.0.0.0

### 3. Radiation Emission

#### 3.1. Radiation Emission Limits(15.209&231)

Frequency (MHz)	Field Strength Limits at 3 metres (watts, e.i.r.p.)		
	uV/m	dB uV/m	Measurement distance(m)
0.009-0.490	2400/F(kHz)	XX	300
0.490-1.705	24000/F(kHz)	XX	30
1.705-30	30	29.5	30
30~88	100(3nW)	40	3
88~216	150(6.8nW)	43.5	3
216~960	200(12nW)	46	3
Above960	500(75nW)	54	3
Carrier frequency		75.6(AV)	3
Carrier frequency		95.6(PK)	3

Fundamental frequency (MHz)	Field strength of fundamental (microvolts/meter)	Field strength of spurious emissions (microvolts/meter)
40.66-40.70	2,250	225
70-130	1,250	125
130-174	<sup>1</sup> 1,250 to 3,750	<sup>1</sup> 125 to 375
174-260	3,750	375
260-470	<sup>1</sup> 3,750 to 12,500	<sup>1</sup> 375 to 1,250
Above 470	12,500	1,250

**NOTE:**

- The tighter limit applies at the band edges.
- Emission Level(dB uV/m)=20log Emission Level(Uv/m)

#### 3.2. Test Setup

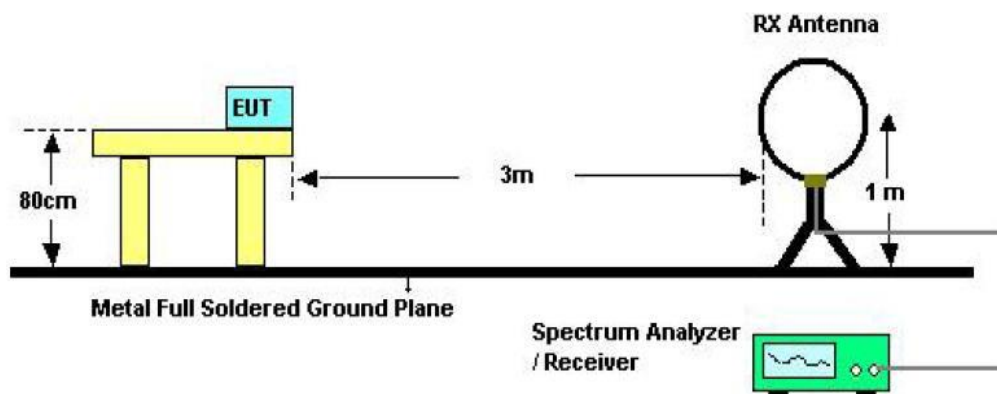

Below 30MHz Test Setup

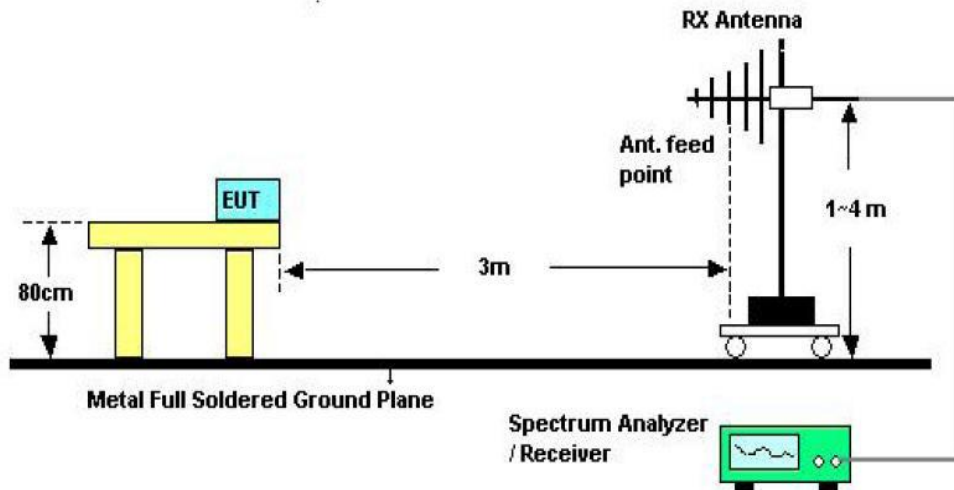

Above 30MHz Test Setup

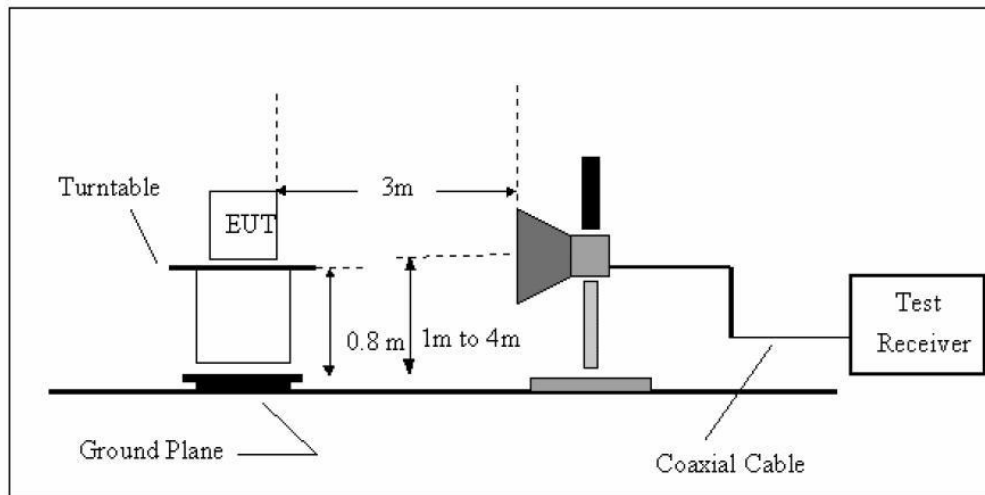

Above 1GHz Test Setup

### 3.3. Test Procedure

- The measuring distance of 3m shall be used for measurements at frequency up to 1GHz and above 1GHz, The EUT was placed on a rotating 0.8 m high above ground, The table was rotated 360 degrees to determine the position of the highest radiation
- The Test antenna shall vary between 1m and 4m, Both Horizontal and Vertical antenna are set to make measurement.
- The initial step in collecting conducted emission data is a spectrum analyzer Peak detector mode pre-scanning the measurement frequency range. Significant Peaks are then marked. and then Quasi Peak Detector mode remeasured
- If Peak value comply with QP limit Below 1GHz. The EUT deemed to comply with QP limit. But the Peak value and average value both need to comply with applicable limit above 1GHz.
- For the actual test configuration, please see the test setup photo.

### 3.4. Test Equipment Setting For emission test.

9kHz~150kHz	RBW 200Hz	VBW 1kHz
150kHz~30MHz	RBW 9kHz	VBW 30kHz

---

30MHz~1GHz	RBW 120kHz	VBW 300kHz
Above 1GHz	RBW 1MHz	VBW 3MHz

### 3.5. Test Condition

Continual Transmitting in maximum power(The new battery be used during Test)

### 3.6. Test Result

We have scanned the 10th harmonic from 9KHz to the EUT.  
Detailed information please see the following page.

From 9KHz to 30MHz: Conclusion: PASS

Note: The amplitude of spurious emissions which are attenuated by more than 20dB below the permissible value has no need to be reported.

**Notes:** 1 --Means other frequency and mode comply with standard requirements and at least have 20dB margin.

Correct Factor=Cable Loss+Antenna Factor-Amplifier Gain

Measurement Result=Reading + Correct Factor

Margin=Measurement Result-Limit

2 -Spectrum setting:

a. Peak setting 30MHz-1GHz, RBW=100kHz, VBW=300kHz.

3- PK measure result values is less than the AVG limit values, so AV measure result values test not applicable.

Radiated Emissions Result of Inside band  
Below 1GHz:

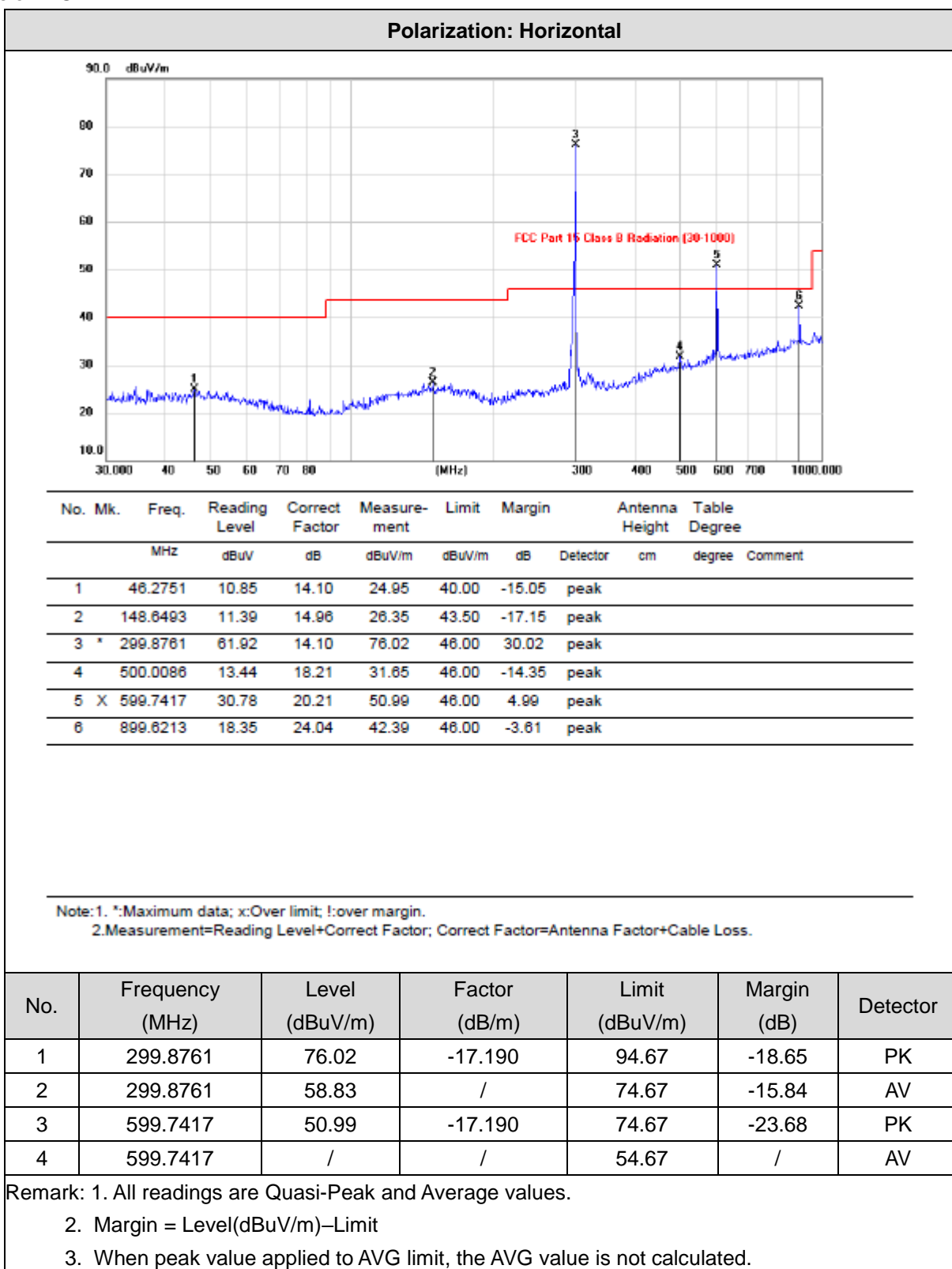

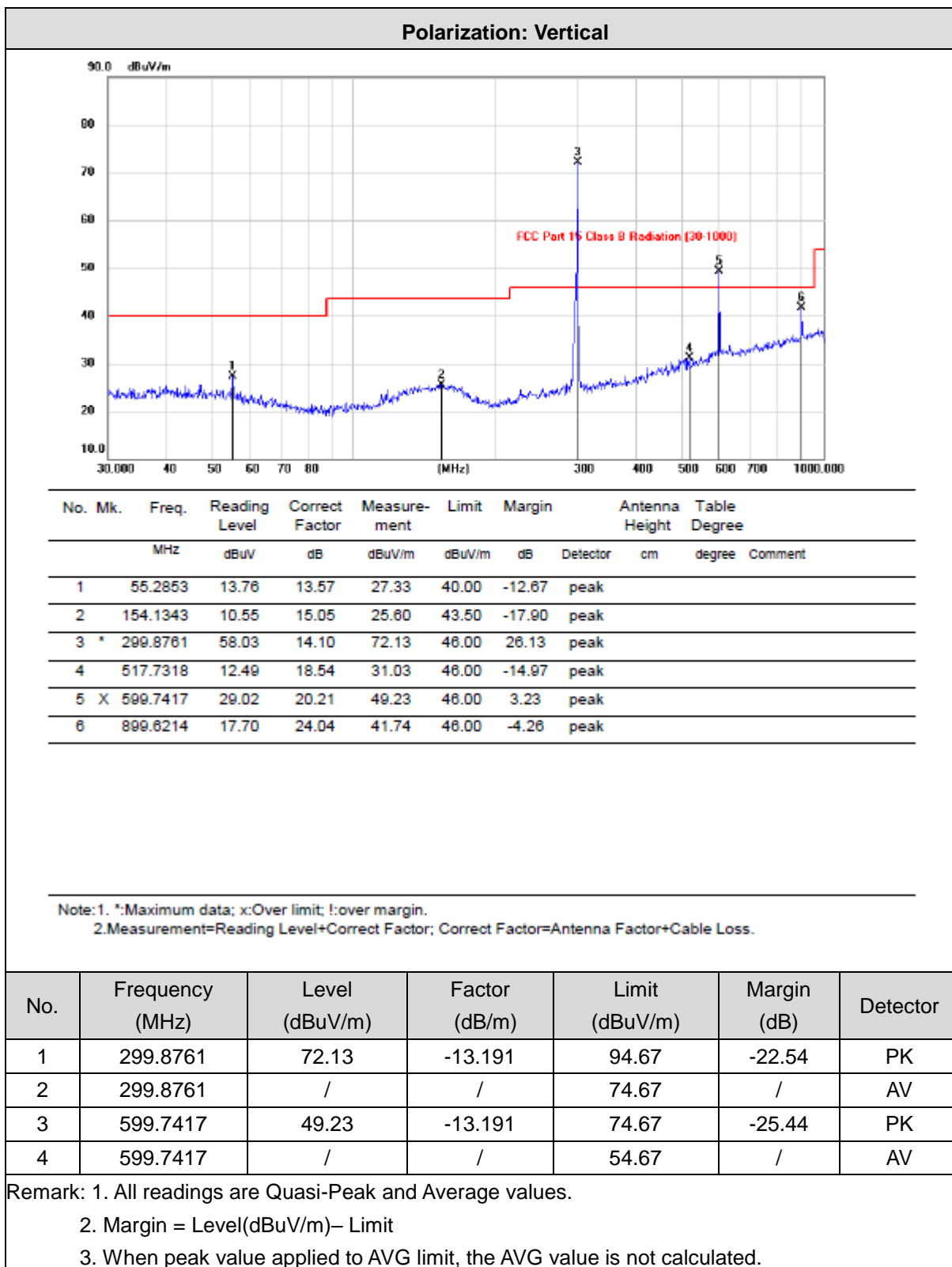

Above 1GHz:

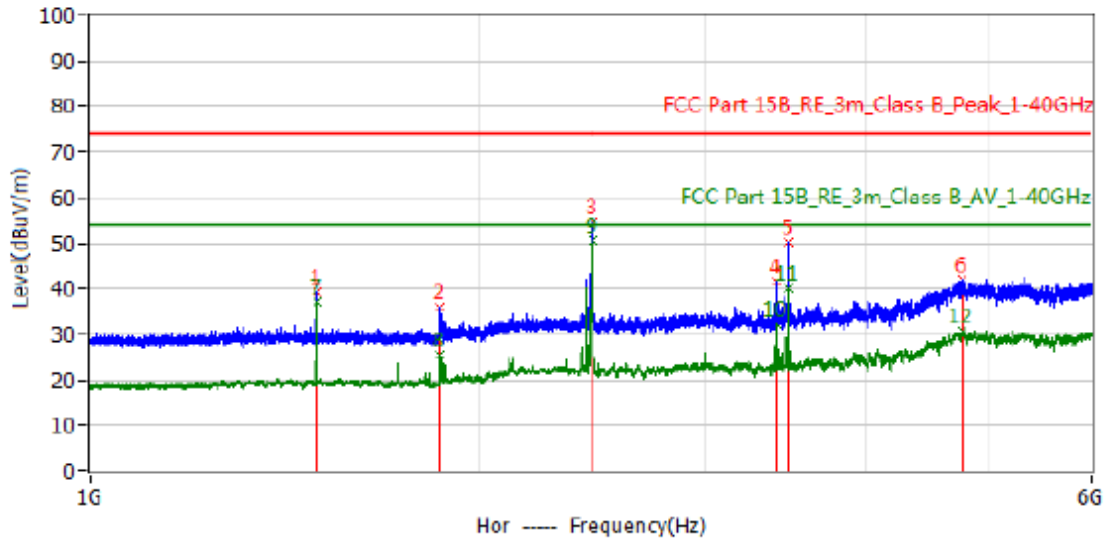
**Polarization: Horizontal**

No.	Frequency	Limit dBuV/m	Level dBuV/m	Margin dB	Factor dB/m	Detector	Height cm	Height cm	Angle deg
1*	1.499GHz	74.0	39.4	-34.6	-22.0	PK	Hor	200.0	0.0
2*	1.863GHz	74.0	35.8	-38.2	-21.1	PK	Hor	200.0	0.0
3*	2.453GHz	74.0	54.8	-19.2	-17.8	PK	Hor	200.0	0.0
4*	3.406GHz	74.0	41.5	-32.5	-16.1	PK	Hor	200.0	204.0
5*	3.482GHz	74.0	50.1	-23.9	-15.5	PK	Hor	200.0	249.0
6*	4.760GHz	74.0	41.8	-32.2	-8.9	PK	Hor	200.0	176.0
7*	1.499GHz	54.0	37.1	-16.9	-22.0	AV	Hor	200.0	0.0
8*	1.862GHz	54.0	25.3	-28.7	-21.1	AV	Hor	200.0	0.0
9*	2.450GHz	54.0	50.5	-3.5	-17.8	AV	Hor	200.0	0.0
10*	3.409GHz	54.0	32.3	-21.7	-16.1	AV	Hor	200.0	204.0
11*	3.484GHz	54.0	39.9	-14.1	-15.5	AV	Hor	200.0	0.0
12*	4.763GHz	54.0	30.7	-23.3	-8.9	AV	Hor	200.0	359.0



## Polarization: Vertical

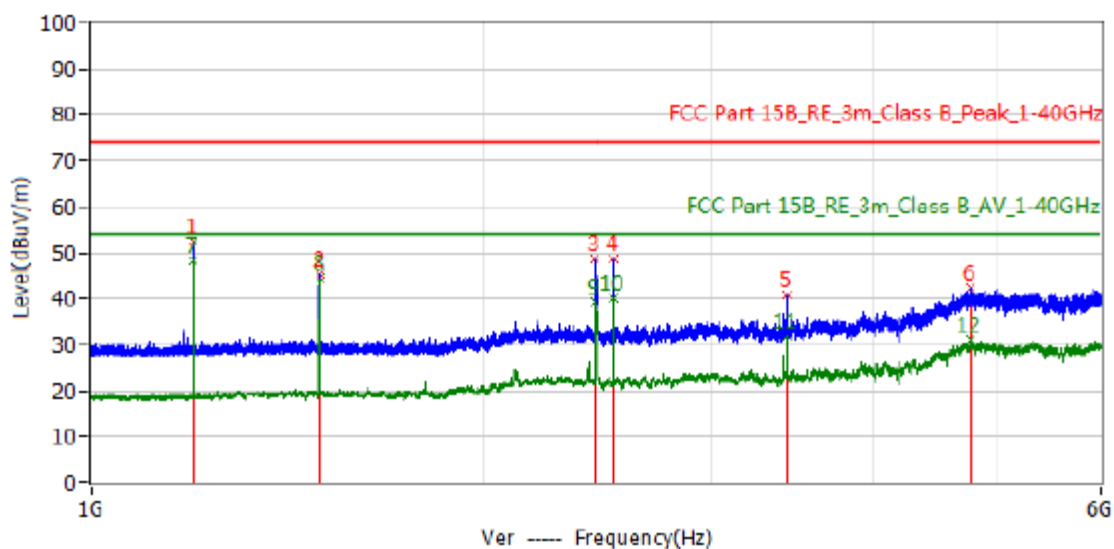

No.	Frequency	Limit dBuV/m	Level dBuV/m	Margin dB	Factor dB/m	Detector	Height cm	Height cm	Angle deg
1*	1.199GHz	74.0	52.3	-21.7	-22.7	PK	Ver	100.0	1.0
2*	1.499GHz	74.0	45.3	-28.7	-22.0	PK	Ver	100.0	0.0
3*	2.440GHz	74.0	48.6	-25.4	-17.8	PK	Ver	100.0	276.0
4*	2.523GHz	74.0	48.8	-25.2	-17.7	PK	Ver	100.0	0.0
5*	3.430GHz	74.0	40.8	-33.2	-15.9	PK	Ver	100.0	330.0
6*	4.765GHz	74.0	42.2	-31.8	-8.9	PK	Ver	100.0	138.0
7*	1.199GHz	54.0	48.4	-5.6	-22.7	AV	Ver	100.0	1.0
8*	1.499GHz	54.0	44.4	-9.6	-22.0	AV	Ver	100.0	0.0
9*	2.441GHz	54.0	39.2	-14.8	-17.8	AV	Ver	100.0	276.0
10*	2.523GHz	54.0	40.0	-14.0	-17.7	AV	Ver	100.0	0.0
11*	3.430GHz	54.0	31.9	-22.1	-15.9	AV	Ver	100.0	330.0
12*	4.761GHz	54.0	31.0	-23.0	-8.9	AV	Ver	100.0	240.0

## Duty cycle

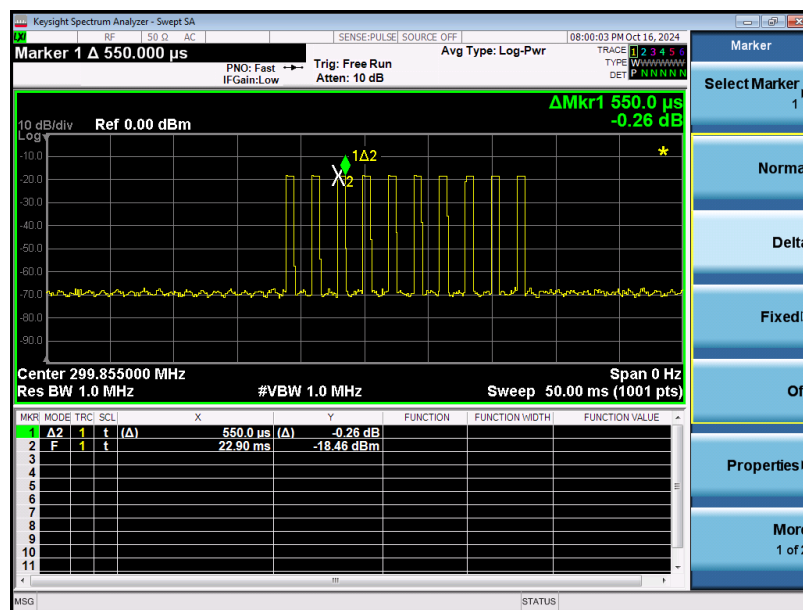
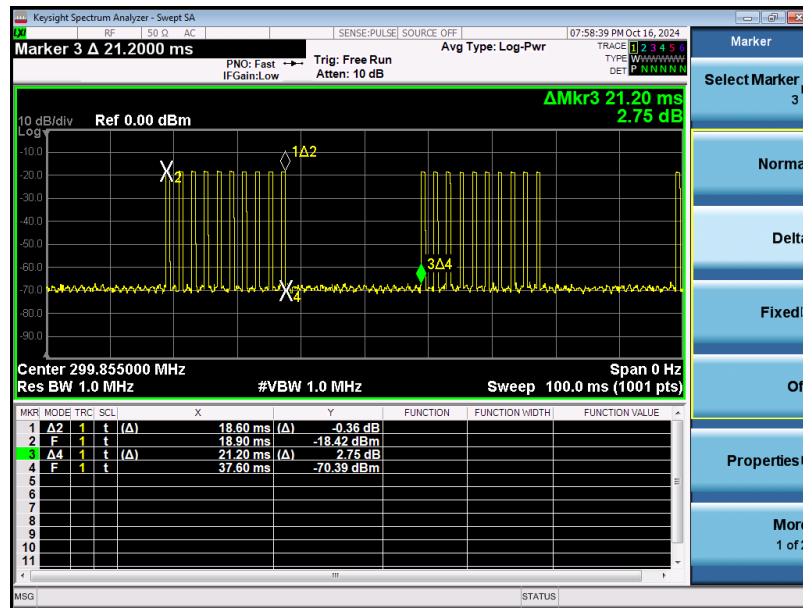

$$T_{on}=0.55\text{ms}\times 10=5.5\text{ms}, T_p=39.8\text{ms}$$

$$\text{So Duty Cycle} = T_{on}/T_p=5.5/39.8\text{ms}=0.138$$

Average should be determined by duty cycle factor.

the total on time in 39.8ms is 5.5ms,

$$\text{Duty cycle factor} = 20 \log (5.5/39.8) = -17.190$$

## 4. Power Line Conducted Emission

### 4.1. Conducted Emission Limits (15.209)

Frequency MHz	Limits dB( $\mu$ V)	
	Quasi-peak Level	Average Level
0.15 -0.50	66 -56*	56 - 46*
0.50 -5.00	56	46
5.00 -30.00	60	50

Notes: 1. \*Decreasing linearly with logarithm of frequency.

2. The lower limit shall apply at the transition frequencies.

3. The limit decreases in line with the logarithm of the frequency in the rang of 0.15 to 0.50 MHz.

### 4.2. Test Setup

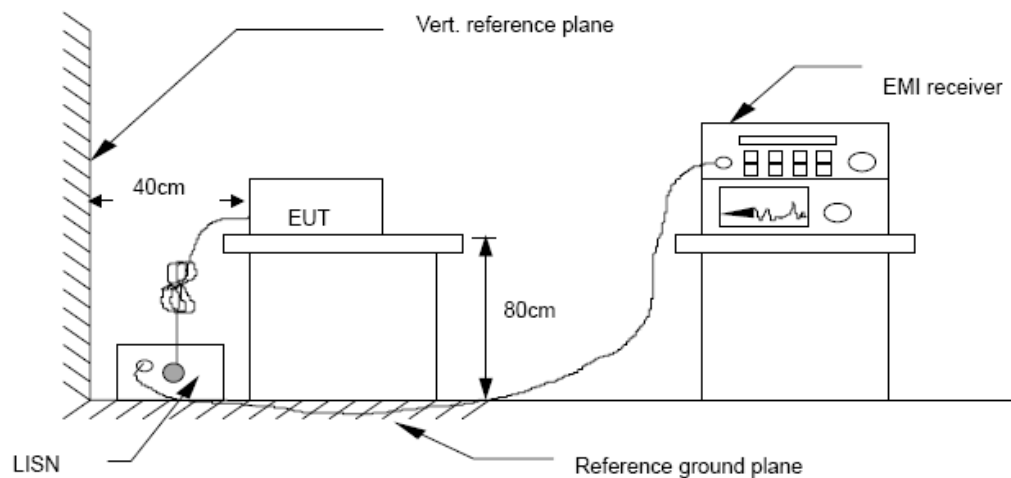

### 4.3. Test Procedure

The EUT is put on the plane 0.8m high above the ground by insulating support and is connected to the power mains through a line impedance stabilization network (L.I.S.N.). This provides a 50ohm coupling impedance for the EUT system. Please refer the block diagram of the test setup and photographs. Both sides of AC lines are checked to find out the maximum conducted emission. In order to find the maximum emission levels, the relative positions of equipment and all of the interface cables shall be changed according to ANSI C63.10:2013 on Conducted Emission Measurement.

The bandwidth of test receiver (R & S ESCI) is set at 9 kHz.

#### 4.4. Test Results

EUT power supply by battery, so the test not applicable.

## 5. Occupied bandwidth

### 5.1. Test Limit

Please refer section 15.231

According to §15.231(C), The bandwidth of the emission shall be no wider than 0.25% of the center frequency for devices operating above 70MHz and below 900MHz.

### 5.2. Method of Measurement

a) The bandwidth is measured at an amplitude level reduced 20dB from the reference level.

The reference level is the level of the highest amplitude signal observed from the transmitter at the fundamental frequency. Once the reference level is established, the equipment is conditioned with typical modulating signal to produce the worst-case (i.e. the widest) bandwidth.

b) The test receiver RBW set 30KHz, VBW set 30KHz, Sweep time set auto.

### 5.3. Test Setup



### 5.4. Test Results

Mode	Freq (MHz)	20dB Bandwidth (kHz)	99% Bandwidth(kHz)	Limit (kHz)	Conclusion
FSK	300	602.3	/	750	PASS

Note:

Limit = 300MHz \* 0.25% = 750 kHz

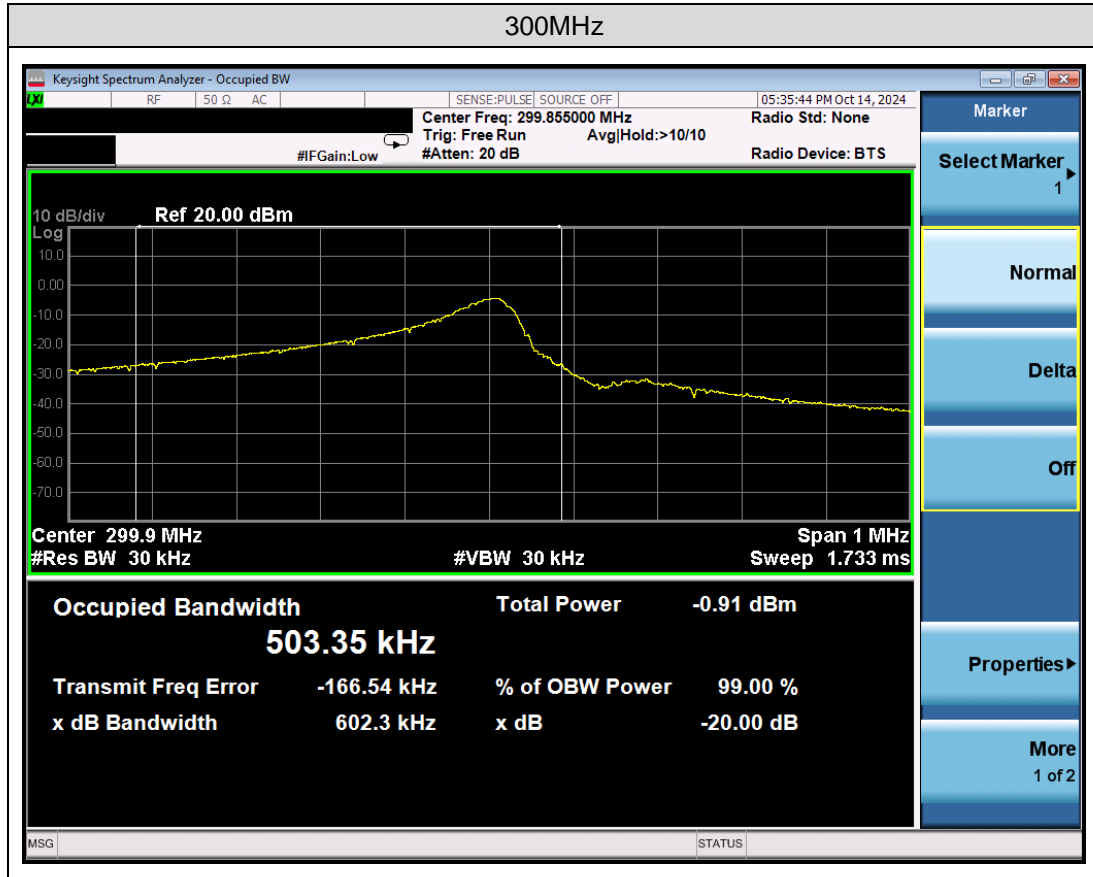

## 6. Transmission Time

### 6.1. Test Limit

Please refer section 15.231

According to §15.231(a)(1), A manually operated transmitter shall employ a switch that will automatically deactivate the transmitter within not more than 5 seconds of being released.

### 6.2. Method of Measurement

6.2.1. Place the EUT on the table and set it in transmitting mode.

6.2.2. Remove the antenna from the EUT and then connect a low loss RF cable from the antenna port to the spectrum analyzer.

6.2.3. Set spectrum analyzer Center= 315MHz&390MHz, Span = 0MHz, Sweep = 5s.

6.2.4. Set the spectrum analyzer as RBW, VBW=1MHz,

6.2.5. Max hold, view and count how many channel in the band.

### 6.3. Test Setup



### 6.4. Test Results

Freq (MHz)	Test Result(s)	Limit (s)	Conclusion
300	0.745	< 5s	PASS

EUT After Release the button, EUT emission Continue 0.745seconds, Compliance with 15.231 a(1) section.

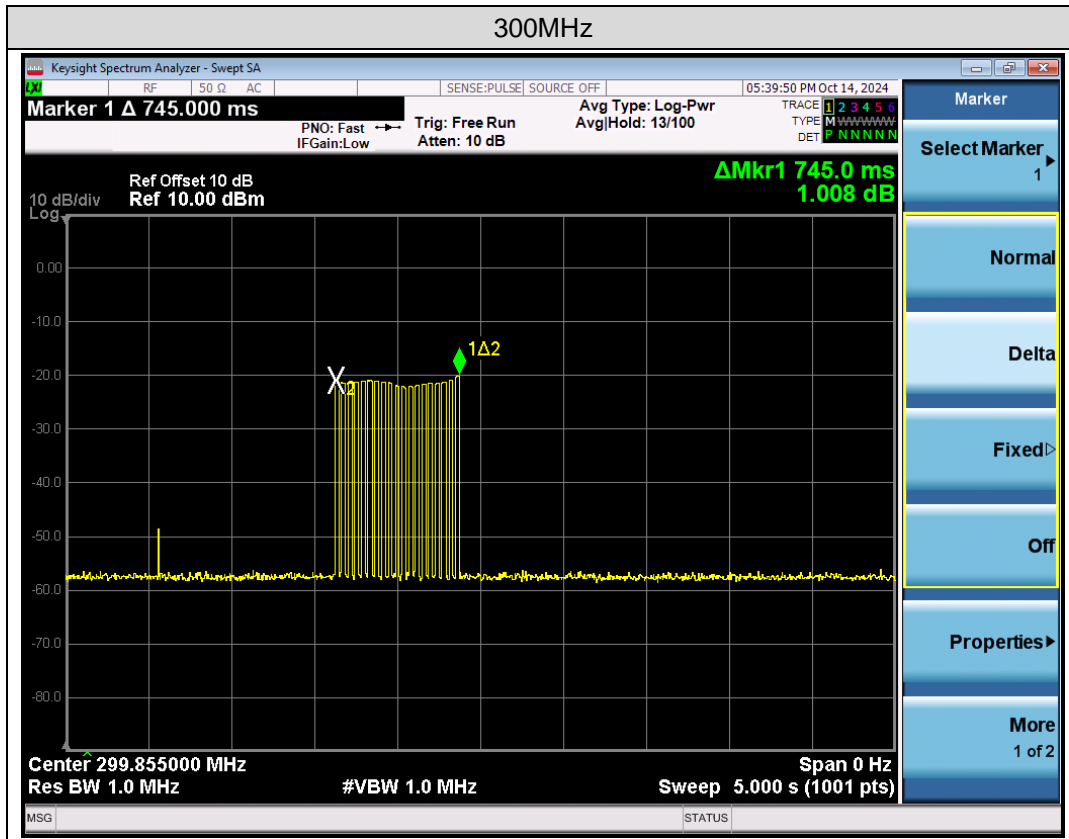



## **7. Antenna Requirement**

### **7.1. Standard Requirement**

An intentional radiator shall be designed to ensure that no antenna other than that furnished by the responsible party shall be used with the device. The use of a permanently attached antenna or of an antenna that uses a unique coupling to the intentional radiator shall be considered sufficient to comply with the provisions of this Section. The manufacturer may design the unit so that a broken antenna can be replaced by the user, but the use of a standard antenna jack or electrical connector is prohibited.

### **7.2. Antenna Connected Construction**

The directional gains of antenna used for transmitting is 0 dBi, and the antenna connector is designed with permanent attachment and no consideration of replacement. Please see EUT photo for details.

### **7.3. Result**

The EUT antenna is internal antenna. It comply with the standard requirement.

## 8. Test Setup Photo

Photos of Radiated emission

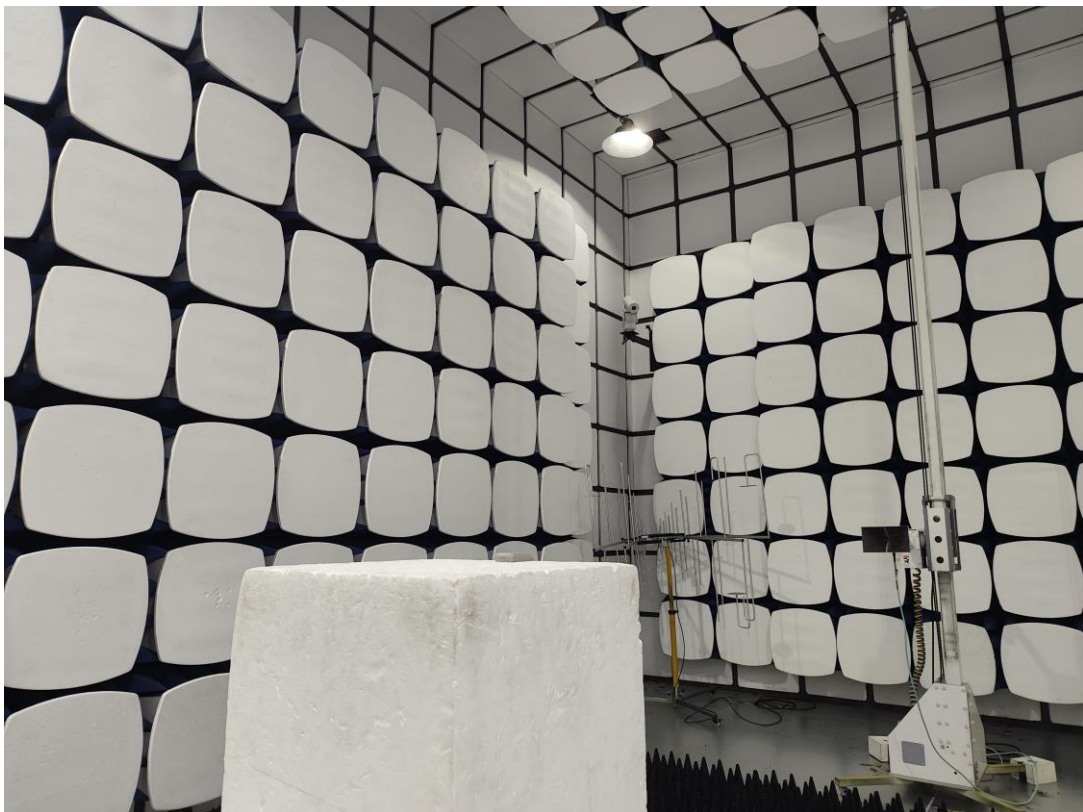
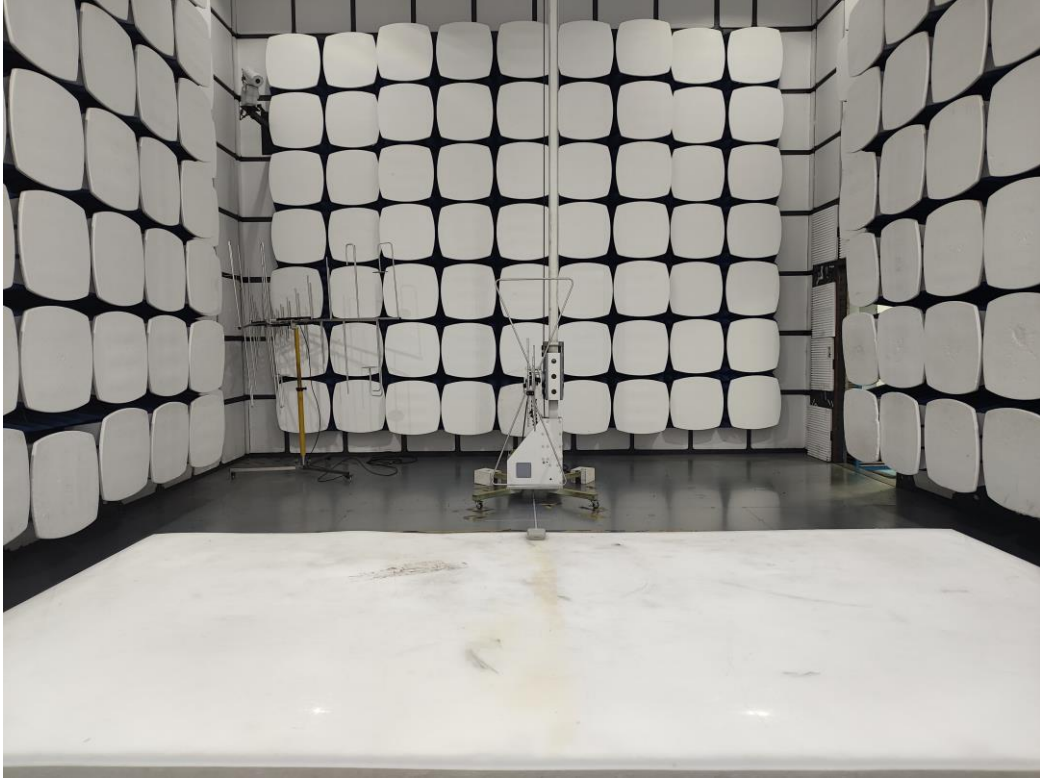



-----END OF THE REPORT-----