



# Test Report

## FCC Part15 Subpart C & ISED RSS-247 Issue 2

Product Name : Cassia Bluetooth Router  
Model No. : S1000 、 S1000-10 、 S1000-20 、 S1000-30 、  
S1100 、 S1100-10 、 S1100-20 、 S1100-30  
FCC ID : 2ALGLS1000  
IC : 22505-S1000

Applicant : CASSIA NETWORKS , INC  
Address : 1840 Majestic Way, San Jose, CA 95132, USA

Date of Receipt : Mar. 03rd, 2017  
Test Date : Mar. 03rd, 2017~ May. 31st, 2017  
Issued Date : Jun. 21st, 2017  
Report No. : 1732001R-RF-US-P06V01  
Report Version : V2.0

The test results relate only to the samples tested.

The test results shown in the test report are traceable to the national/international standard through the calibration of the equipment and evaluated measurement uncertainty herein.

This report must not be used to claim product endorsement by TAF any agency of the government.

The test report shall not be reproduced without the written approval of DEKRA Testing & Certification (Suzhou) Co., Ltd.

# Test Report Certification

Issued Date : Jun. 21st, 2017  
Report No. : 1732001R-RF-US-P06V01



Product Name : Cassia Bluetooth Router  
 Applicant : CASSIA NETWORKS, INC  
 Address : 1840 Majestic Way, San Jose, CA 95132, USA  
 Manufacturer : CASSIA NETWORKS, INC  
 Address : 1840 Majestic Way, San Jose, CA 95132, USA  
 Model No. : S1000、S1000-10、S1000-20、S1000-30、S1100、S1100-10、  
 S1100-20、S1100-30  
 FCC ID : 2ALGLS1000  
 IC : 22505-S1000  
 EUT Voltage : S1000、S1000-10、S1000-20、S1000-30: DC 5V/2A  
 S1100、S1100-10、S1100-20、S1100-30: DC 5V/2A or  
 57Vdc、350mA (PoE)  
 Test Voltage : AC 120V/60Hz  
 Brand Name : TP-Link  
 Applicable Standard : FCC CFR Title 47 Part 15 Subpart C: 2015  
 ANSI C63.4:2014; ANSI C63.10:2013;  
 KDB 558074 D01v04  
 ISED RSS-Gen Issue 4 / RSS-247 Issue 2  
 Test Result : Complied  
 Performed Location : DEKRA Testing & Certification (Suzhou) Co., Ltd.  
 No.99 Hongye Rd., Suzhou Industrial Park, Suzhou, 215006,  
 Jiangsu, China  
 TEL: +86-512-6251-5088 / FAX: +86-512-6251-5098  
 FCC Registration Number: 800392; IC Lab Code: 4075B

Documented By : Kathy Feng  
 ( Adm. Specialist: Kathy Feng)

Reviewed By : Jack Zhang  
 (Senior Engineer: Jack Zhang)

Approved By : Harry Zhao  
 (Engineering Manager: Harry Zhao)

## TABLE OF CONTENTS

Description	Page
1. General Information.....	6
1.1. EUT Description .....	6
1.2. Working Frequency of Each Channel: .....	6
1.3. Antenna information .....	7
1.4. Mode of Operation.....	8
1.5. Tested System Details .....	8
1.6. Configuration of Tested System.....	9
2. Technical Test.....	11
2.1. Summary of Test Result.....	11
2.2. Test Frequency configuration:.....	12
2.3. Power setting parameter.....	13
2.4. Power vs Data Rate.....	14
2.5. Test Environment.....	15
2.6. Measurement Uncertainty.....	15
3. AC Power Line Conducted Emission.....	16
3.1. Test Equipment.....	16
3.2. Test Setup .....	16
3.3. Limit.....	17
3.4. Test Procedure .....	17
3.5. Test Result.....	18
4. Emissions in restricted frequency bands .....	20
4.1. Test Equipment.....	20
4.2. Test Setup .....	21
4.3. Limit.....	22
4.4. Test Procedure .....	25
4.5. EUT test Axis definition.....	26
4.6. Test Result.....	27
6. Emissions in non-restricted frequency bands .....	34
6.1. Test Equipment.....	34
6.2. Test Setup .....	34
6.3. Limit.....	35
6.4. Test Procedure .....	36
6.5. EUT test Axis definition.....	37
6.6. Test Result.....	38
7. Radiated Emission Band Edge .....	39
7.1. Test Equipment.....	39
7.2. Test Setup .....	40

- 7.3. Limit.....40
- 7.4. Test Procedure .....41
- 7.5. EUT test definition .....42
- 7.6. Duty Cycle .....43
- 7.7. Test Result.....44
- 8. Occupied Bandwidth..... 108
- 8.1. Test Equipment..... 108
- 8.2. Test Setup ..... 108
- 8.3. Limit..... 109
- 8.4. Test Procedure ..... 109
- 8.5. EUT test definition ..... 110
- 8.6. Test Result..... 111
- 9. Fundamental emission output power ..... 112
- 9.1. Test Equipment..... 112
- 9.2. Test Setup ..... 112
- 9.3. Limit..... 113
- 9.4. Test Procedure ..... 114
- 9.5. EUT test definition ..... 115
- 9.6. Test Result..... 116
- 10. Power Spectral Density ..... 119
- 10.1. Test Equipment..... 119
- 10.2. Test Setup ..... 119
- 10.3. Limit..... 119
- 10.4. Test Procedure ..... 120
- 10.5. EUT test definition ..... 121
- 10.6. Test Result..... 122
- 11. Antenna Requirement..... 123
- 11.1. Limit..... 123
- 11.2. Antenna Connector Construction..... 123

### History of This Test Report

REPORT NO.	VERSION	DESCRIPTION	ISSUED DATE
1732001R-RF-US-P06V01	V1.0	Initial Issued Report	Jun. 09th, 2017
1732001R-RF-US-P06V01	V2.0	Change the product name	Jun. 21st, 2017

## 1. General Information

### 1.1. EUT Description

Product Name	Cassia Bluetooth Router
Model No.	S1000、S1000-10、S1000-20、S1000-30、S1100、S1100-10、S1100-20、S1100-30
EUT Voltage	S1000、S1000-10、S1000-20、S1000-30: DC 5V/2A S1100、S1100-10、S1100-20、S1100-30: DC 5V/2A or 57Vdc、350mA (PoE)
Test Voltage	AC 120V / 60Hz
Frequency Range	For 2.4GHz Band 802.11b/g/n(20MHz): 2412~2462MHz 802.11n(40MHz): 2422~2452MHz
Channel Number	For 2.4GHz Band 802.11b/g/n(20MHz): 11 802.11n(40MHz): 7
Type of Modulation	802.11b: DSSS 802.11g: OFDM
Data Rate	802.11g: 6/9/12/18/24/36/48/54 Mbps 802.11b: 1/2/5.5/11 Mbps 802.11n: up to 150 Mbps
Channel Control	Auto

Note : model difference

The PCB of all models are same, only the power supply is difference, S1000 is powered by adapter, S1100 is not only powered by adapter, but also powered by POE.

### 1.2. Working Frequency of Each Channel:

802.11b/g/n(20MHz) Working Frequency of Each Channel:							
Channel	Frequency	Channel	Frequency	Channel	Frequency	Channel	Frequency
01	2412 MHz	02	2417 MHz	03	2422 MHz	04	2427 MHz
05	2432 MHz	06	2437 MHz	07	2442 MHz	08	2447 MHz
09	2452 MHz	10	2457 MHz	11	2462 MHz	N/A	N/A
802.11n(40MHz) Working Frequency of Each Channel:							
Channel	Frequency	Channel	Frequency	Channel	Frequency	Channel	Frequency
03	2422 MHz	04	2427 MHz	05	2432 MHz	06	2437 MHz
07	2442 MHz	08	2447 MHz	09	2452 MHz	N/A	N/A

**1.3. Antenna information**

Antenna manufacturer	N/A					
Antenna Delivery	<input checked="" type="checkbox"/>	1*TX+1*RX	<input type="checkbox"/>	2*TX+2*RX	<input type="checkbox"/>	3*TX+3*RX
Antenna technology	<input checked="" type="checkbox"/>	SISO				
	<input type="checkbox"/>	MIMO	<input type="checkbox"/>	Basic		
			<input type="checkbox"/>	CDD		
			<input type="checkbox"/>	Beam-forming		
Antenna Type	<input type="checkbox"/>	External	<input type="checkbox"/>	Dipole		
	<input checked="" type="checkbox"/>	Internal	<input checked="" type="checkbox"/>	PIFA		
			<input type="checkbox"/>	PCB		
			<input type="checkbox"/>	Ceramic Chip Antenna		
			<input type="checkbox"/>	Metal plate type F antenna		
Antenna Gain	3.2dBi					

### 1.4. Mode of Operation

Pre-Test Mode	
Mode 1: Transmit by 802.11b with S1000 Powered by adapter	
Mode 2: Transmit by 802.11b with S1100 Powered by adapter	
Mode 3: Transmit by 802.11b with S1100 Powered by adapter POE	
Final Test Mode	
Emission	Mode 1: Transmit-1Mbps(GFSK_BLE) with S1100 Power by adapter

Test Modes List
Mode 1: Transmit by 802.11b
Mode 2: Transmit by 802.11g
Mode 3: Transmit by 802.11n(20MHz)
Mode 4: Transmit by 802.11n(40MHz)

### 1.5. Tested System Details

The types for all equipment, plus descriptions of all cables used in the tested system (including inserted cards) are:

Product	Manufacturer	Model No.	Serial No.	Power Cord
1   Notebook	DELL	PP19L	JH097 A01	Power by adapter
2   USB Disk	Corsar	VOYAGER	N/A	N/A
3   Radio Communicati on Tester	R&S	CMU200	106388	N/A



### 1.6. Configuration of Tested System

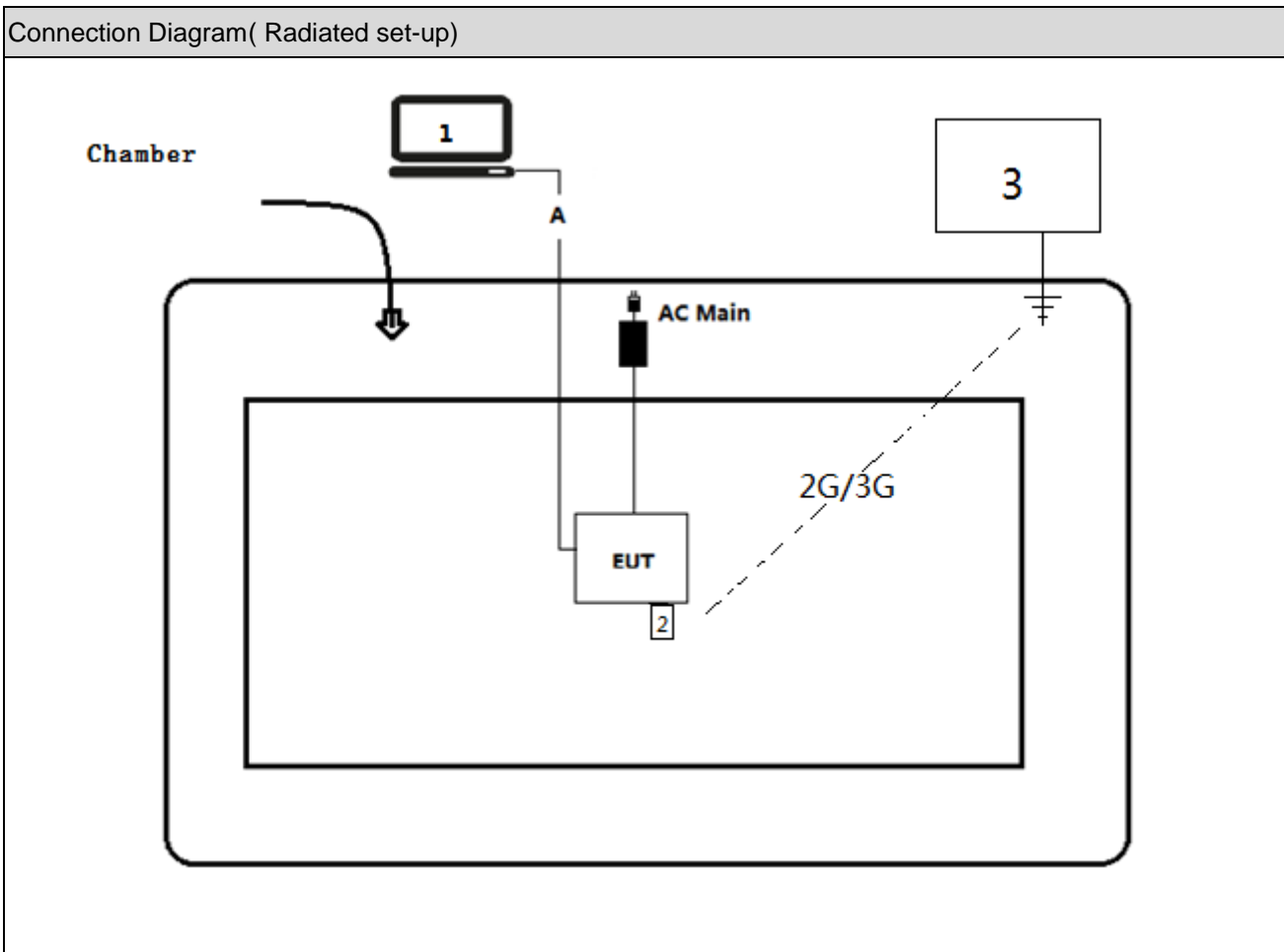

Connection Diagram( Conducted set-up)

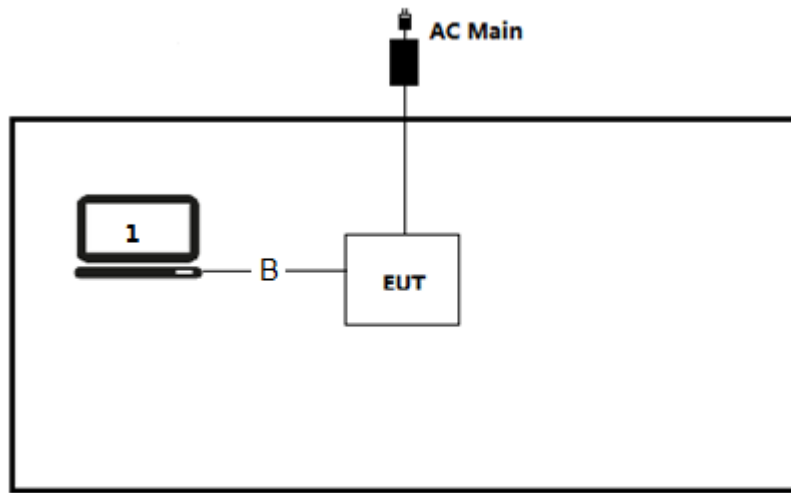

Connection Diagram

A	LAN Cable	Shielded >15m
B	LAN Cable	Shielded >1.5m

## 2. Technical Test

### 2.1. Summary of Test Result

For FCC

Performed Test Item	Normative References	Worst case mode	Limit	Result
AC Power Line Conducted Emission	FCC CFR Title 47 Part 15 Subpart C: 2015 Section 15.207	Mode 1	FCC 15.207	PASS
Emissions in restricted frequency bands	FCC CFR Title 47 Part 15 Subpart C: 2015 Section 15.209	Mode 1	FCC 15.209	PASS
Emissions in non-restricted frequency bands	FCC CFR Title 47 Part 15 Subpart C: 2015 Section 15.247(d)	Mode 1	$\geq 20\text{dBc}$	PASS
Radiated Emission Band Edge	FCC CFR Title 47 Part 15 Subpart C: 2015 15.247(d)	Mode 1	FCC 15.209	PASS
Occupied Bandwidth	FCC CFR Title 47 Part 15 Subpart C: 2015 Section 15.247(a)(2)	Mode 1	$\geq 500\text{kHz}$	PASS
Fundamental emission output power	FCC CFR Title 47 Part 15 Subpart C: 2015 Section 15.247(b)(3)	Mode 1	$\leq 30\text{dBm}$	PASS
Power Spectral Density	FCC CFR Title 47 Part 15 Subpart C: 2015 Section 15.247(e)	Mode 1	$\leq 8\text{dBm}/3\text{kHz}$	PASS
Antenna Requirement	FCC CFR Title 47 Part 15 Subpart C: 2015 Section 15.203	N/A	FCC 15.203	PASS

For ISED

Performed Test Item	Normative References	Worst case mode	Limit	Result
AC Power Line Conducted Emission	RSS-Gen Issue 4 Section 8.8	Mode 1	RSS-Gen	PASS
Emissions in restricted frequency bands	RSS-Gen Issue 4 Section 8.9	Mode 1	RSS-Gen	PASS
Emissions in non-restricted frequency bands	RSS-247 Issue 2 Section A5.5	Mode 1	$\geq 20\text{dBc}$	PASS
Radiated Emission Band Edge	RSS-247 Issue 2 Section A5.5	Mode 1	RSS-247	PASS
Occupied Bandwidth	RSS-Gen Issue 4 Section 6.6 RSS-247 Issue 2 Section A5.2(1)	Mode 1	$\geq 500\text{kHz}$	PASS
Fundamental emission output power	RSS-247 Issue 2 Section A5.4(4)	Mode 1	$\leq 30\text{dBm}$	PASS
Power Spectral Density	RSS-247 Issue 2 Section A5.2(2)	Mode 1	$\leq 8\text{dBm}/3\text{kHz}$	PASS
Antenna Requirement	RSS-Gen Issue 4 Section 8.3	N/A	RSS-Gen Issue 4	PASS

**2.2. Test Frequency configuration:**

Modulation Mode	Channel	Frequency	Channel	Frequency	Channel	Frequency
<b>802.11b</b>	01	2412 MHz	06	2437 MHz	11	2462MHz
<b>802.11g</b>	01	2412 MHz	06	2437 MHz	11	2462MHz
<b>802.11n(20MHz)</b>	01	2412 MHz	06	2437 MHz	11	2462MHz
<b>802.11n(40MHz)</b>	03	2422 MHz	06	2437 MHz	09	2452MHz

### 2.3. Power setting parameter

Modulation Mode	Test Frequency	Power setting
802.11b	2412	16
	2422	17
	2437	18
	2452	17
	2462	15
802.11g	2412	14
	2422	15
	2437	18
	2452	15
	2462	13
802.11n(20MHz)	2412	13
	2422	14
	2437	18
	2452	13
	2462	12
802.11n(40MHz)	2422	8
	2427	10
	2437	14
	2447	10
	2452	8

## 2.4. Power vs Data Rate

MCS Index for 802.11n	Spatial Streams	Data Rate (Mbps)						
		802.11b	802.11g		20MHz Bandwidth		40MHz Bandwidth	
					800ns GI	400ns GI	800ns GI	400ns GI
0	1	1	6	---	6.5	7.2	13.5	15.0
1	1	2	9	---	13.0	14.4	27.0	30.0
2	1	5.5	12	---	19.5	21.7	40.5	45.0
3	1	11	18	---	26.0	28.9	54.0	60.0
4	1	---	24	---	39.0	43.3	81.0	90.0
5	1	---	36	---	52.0	57.8	108.0	120.0
6	1	---	48	---	58.5	65.0	121.5	135.0
7	1	---	54	---	65.0	72.2	135.0	150.0

Note 1 : The blue form is the maximum power data rate

## 2.5. Test Environment

Items	Required (IEC 68-1)	Actual
Temperature (°C)	15-35	21
Humidity (%RH)	25-75	50
Barometric pressure (mbar)	860-1060	950-1000

## 2.6. Measurement Uncertainty

Test Items	Uncertainty
AC Power Line Conducted Emission	$\pm 2.02\text{dB}$
Radiated Emission	Below 1GHz $\pm 3.8\text{ dB}$
	Above 1GHz $\pm 3.9\text{ dB}$
RF Antenna Port Conducted Emission	$\pm 1.27\text{dB}$
Radiated Emission Band Edge	$\pm 3.9\text{dB}$
Occupied Bandwidth	$\pm 1\text{kHz}$
Power Spectral Density	$\pm 1.27\text{dB}$

### 3. AC Power Line Conducted Emission

#### 3.1. Test Equipment

AC Power Line Conducted Emission / TR-1					
Instrument	Manufacturer	Type No.	Serial No.	Cal. Date	Cal. Due Date
EMI Test Receiver	R&S	ESCI	100906	2017.03.05	2018.03.05
Two-Line V-Network	R&S	ENV 216	101189	2016.07.16	2017.07.16
Two-Line V-Network	R&S	ENV 216	101044	2016.09.16	2017.09.16
50ohm Coaxial Switch	Anritsu	MP59B	6200464462	N/A	N/A
50ohm Termination	SHX	TF2	07081402	2016.09.16	2017.09.16
Temperature/Humidity Meter	Zhichen	ZC1-2	TR1-TH	2017.01.05	2018.01.05

Note: All equipments are calibrated with traceable calibrations. Each calibration is traceable to the national or international standards.

#### 3.2. Test Setup

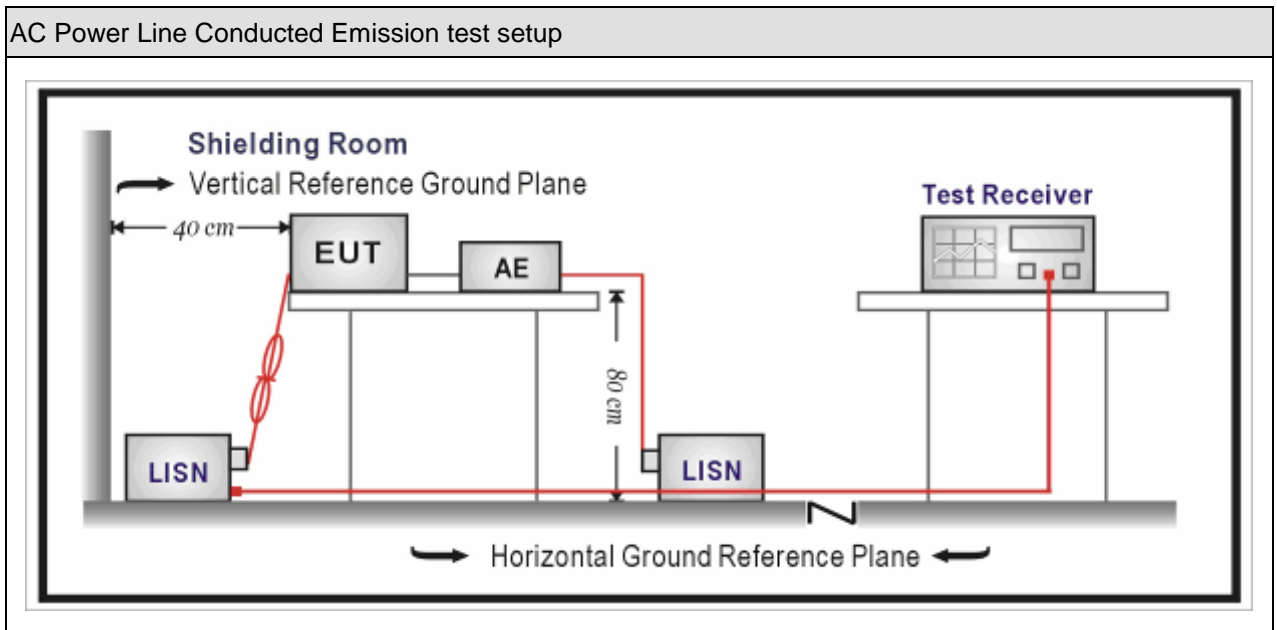



### 3.3. Limit

Frequency of Emission (MHz)	Conducted Limit	
	Quasi-peak (dB $\mu$ V)	Average (dB $\mu$ V)
0.15-0.5	66 to 56	56 to 46
0.5-5	56	46
5-30	60	50

Note 1: The lower limit shall apply at the transition frequencies.  
 Note 2: The limit decreases linearly with the logarithm of the frequency in the range 0.15 MHz to 0.5 MHz.

### 3.4. Test Procedure

Test Method			
	References Rule	Chapter	Item
<input checked="" type="checkbox"/>	ANSI C63.10-2013	6.2	Standard test method for ac power-line conducted emissions from unlicensed wireless devices
<input checked="" type="checkbox"/>	ANSI C63.4-2014	7	AC power-line conducted emission measurements

### 3.5. Test Result

Engineer: Johnson	
Site: TR1	Time: 2017/04/18
Limit: FCC_Part15.107_CE_AC Power_ClassB	Margin: 0
Probe: ENV216_101044(0.009-30MHz)	Polarity: Line
EUT: Cassia Bluetooth Router	Power: AC 120V/60Hz
Note: WiFi + BT	

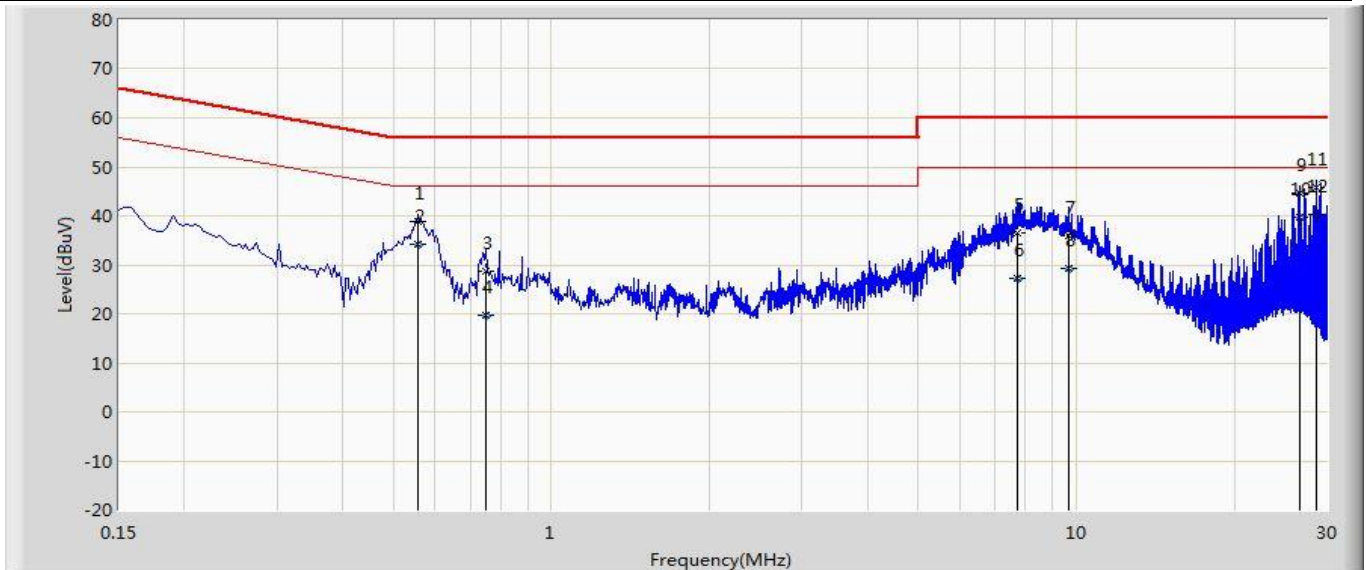

No	Mark	Frequency (MHz)	Measure Level (dBuV)	Reading Level (dBuV)	Over Limit (dB)	Limit (dBuV)	Probe (dB)	Cable (dB)	Amp (dB)	Type
1		0.558	38.782	29.147	-17.218	56.000	9.590	0.045	0.000	QP
2		0.558	34.095	24.461	-11.905	46.000	9.590	0.045	0.000	AV
3		0.750	28.672	19.029	-27.328	56.000	9.592	0.051	0.000	QP
4		0.750	19.845	10.202	-26.155	46.000	9.592	0.051	0.000	AV
5		7.734	36.529	26.712	-23.471	60.000	9.640	0.177	0.000	QP
6		7.734	27.325	17.508	-22.675	50.000	9.640	0.177	0.000	AV
7		9.642	36.038	26.200	-23.962	60.000	9.640	0.198	0.000	QP
8		9.642	29.208	19.370	-20.792	50.000	9.640	0.198	0.000	AV
9		26.610	44.536	34.617	-15.464	60.000	9.584	0.335	0.000	QP
10		26.610	39.611	29.692	-10.389	50.000	9.584	0.335	0.000	AV
11		28.686	45.940	36.022	-14.060	60.000	9.569	0.349	0.000	QP
12	*	28.686	40.158	30.240	-9.842	50.000	9.569	0.349	0.000	AV

**Note:**

1. " \* ", means this data is the worst emission level.
2. Measurement Level = Reading Level + Factor(Probe+Cable-Amp).

Engineer: Johnson	
Site: TR1	Time: 2017/04/18
Limit: FCC_Part15.107_CE_AC Power_ClassB	Margin: 0
Probe: ENV216_101044(0.009-30MHz)	Polarity: Neutral
EUT: Cassia Bluetooth Router	Power: AC 120V/60Hz
Note: WiFi + BT	

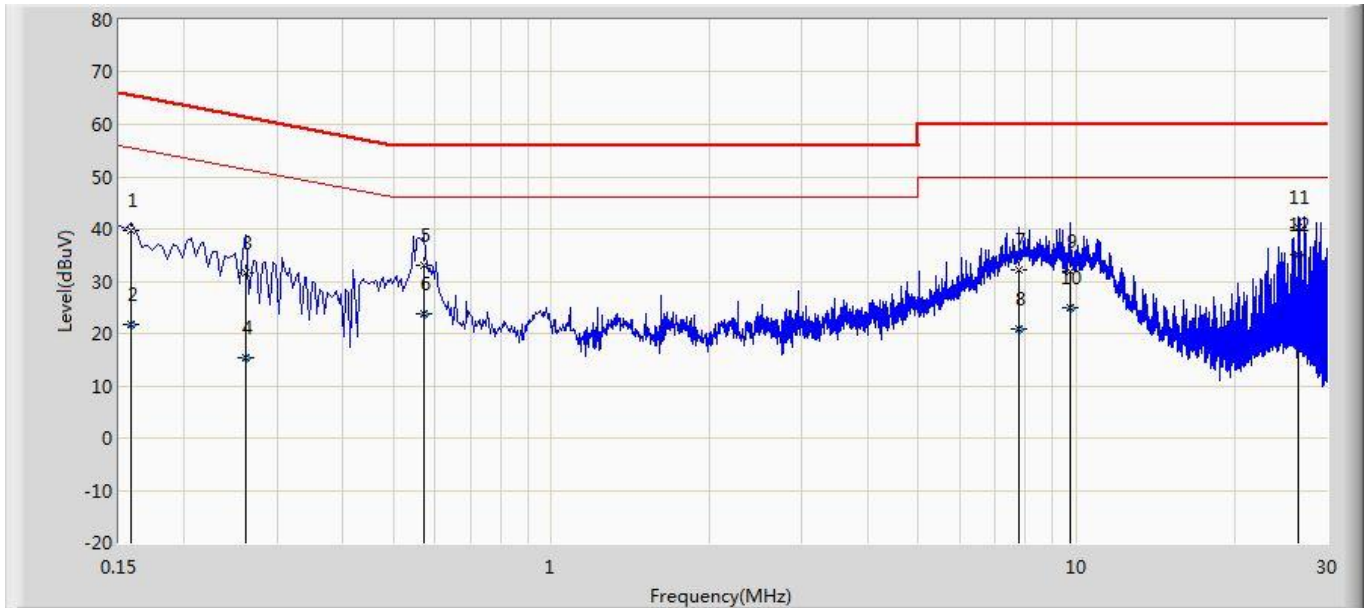

No	Mark	Frequency (MHz)	Measure Level (dBuV)	Reading Level (dBuV)	Over Limit (dB)	Limit (dBuV)	Probe (dB)	Cable (dB)	Amp (dB)	Type
1		0.158	39.694	30.090	-25.874	65.568	9.578	0.026	0.000	QP
2		0.158	21.878	12.274	-33.690	55.568	9.578	0.026	0.000	AV
3		0.262	31.570	21.965	-29.798	61.368	9.572	0.032	0.000	QP
4		0.262	15.402	5.797	-35.966	51.368	9.572	0.032	0.000	AV
5		0.570	32.910	23.274	-23.090	56.000	9.591	0.045	0.000	QP
6		0.570	23.821	14.186	-22.179	46.000	9.591	0.045	0.000	AV
7		7.758	32.153	22.343	-27.847	60.000	9.632	0.178	0.000	QP
8		7.758	20.750	10.940	-29.250	50.000	9.632	0.178	0.000	AV
9		9.706	31.891	22.054	-28.109	60.000	9.639	0.198	0.000	QP
10		9.706	25.039	15.202	-24.961	50.000	9.639	0.198	0.000	AV
11		26.486	40.232	30.254	-19.768	60.000	9.644	0.334	0.000	QP
12	*	26.486	35.105	25.127	-14.895	50.000	9.644	0.334	0.000	AV

**Note:**

1. " \* ", means this data is the worst emission level.
2. Measurement Level = Reading Level + Factor(Probe+Cable-Amp).

## 4. Emissions in restricted frequency bands

### 4.1. Test Equipment

Radiated Emission(Below 1GHz) / AC-2					
Instrument	Manufacturer	Type No.	Serial No.	Cal. Date	Cal. Due Date
EMI Test Receiver	R&S	ESCI	100573	2017.03.29	2018.03.28
Loop Antenna	R&S	HFH2-Z2	833799/003	2016.11.16	2017.11.17
Bilog Antenna	Teseq GmbH	CBL6112D	27611	2016.10.16	2017.10.15
Coaxial Cable	Huber+Suhner	SUCOFLEX 106	AC2-C	2017.03.02	2018.03.01
Temperature/Humidity Meter	Zhichen	ZC1-2	AC2-TH	2017.01.04	2018.01.03
Note: All equipments are calibrated with traceable calibrations. Each calibration is traceable to the national or international standards.					

Radiated Emission(Above 1GHz) / AC-5					
Instrument	Manufacturer	Type No.	Serial No.	Cal. Date	Cal. Due Date
Spectrum Analyzer	Agilent	E4446A	MY45300103	2017.01.04	2018.01.03
Preamplifier	Miteq	NSP1800-25	1364185	2017.05.06	2018.05.05
Preamplifier	QuieTek	AP-040G	CHM-0906001	2017.05.06	2018.05.05
DRG Horn	ETS-Lindgren	3117	00123988	2017.01.22	2018.01.21
Broad-Band Horn Antenna	Schwarzbeck	BBHA9170	294	2016.11.25	2017.11.24
Coaxial Cable	Huber+Suhner	SUCOFLEX 106	AC5-C1	2017.03.02	2018.03.01
Coaxial Cable	Huber+Suhner	SUCOFLEX 106	AC5-C2	2017.03.02	2018.03.01
Coaxial Cable	Huber+Suhner	SUCOFLEX 102	AC5-C3	2017.03.02	2018.03.01
EMI Receiver	Agilent	N9038A	MY51210196	2017.06.10	2018.06.09
Temperature/Humidity Meter	Zhichen	ZC1-2	AC5-TH	2017.01.04	2018.01.03
Note: All equipments are calibrated with traceable calibrations. Each calibration is traceable to the national or international standards.					

### 4.2. Test Setup

Below 30MHz Test Setup:

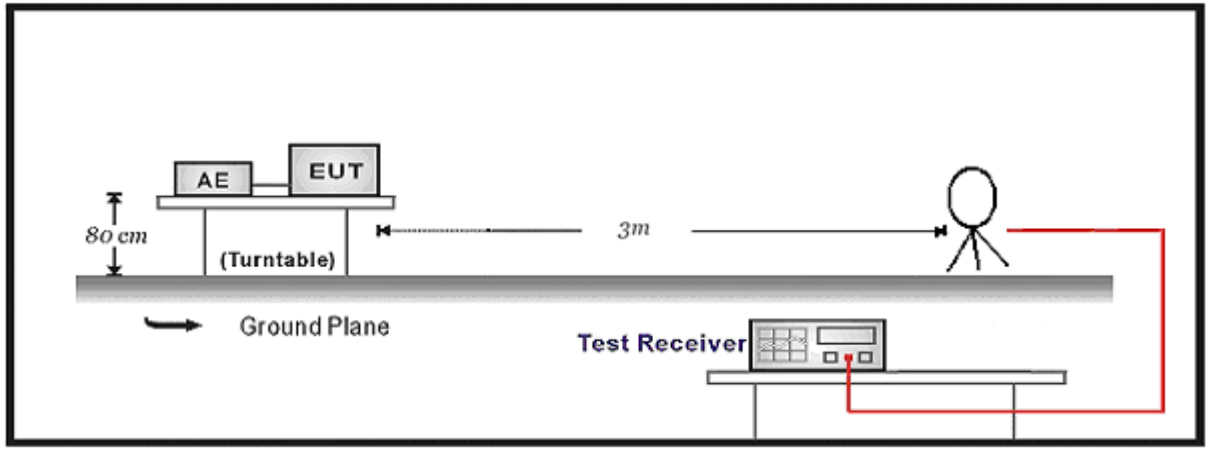

30MHz-1GHz Test Setup:

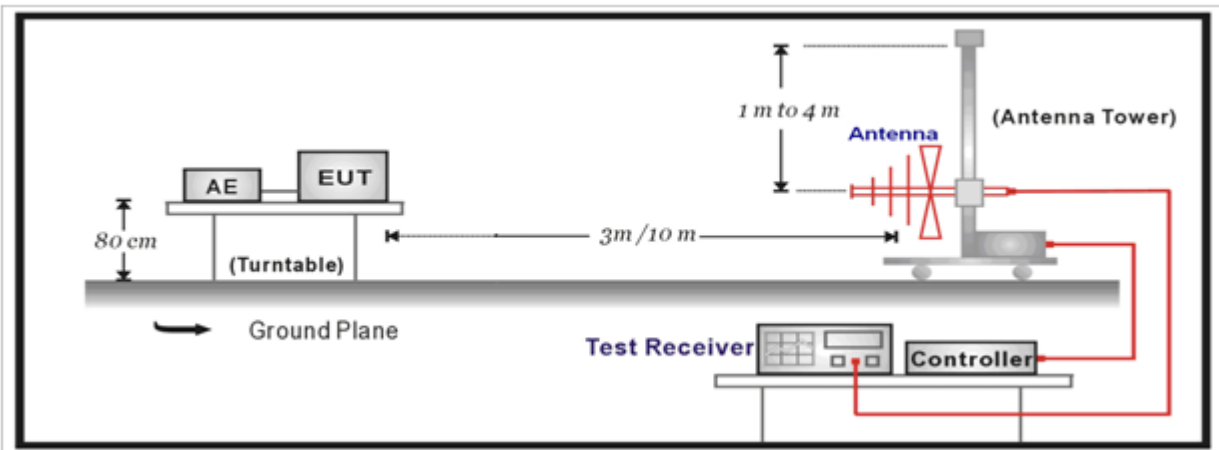

Above 1GHz Test Setup:

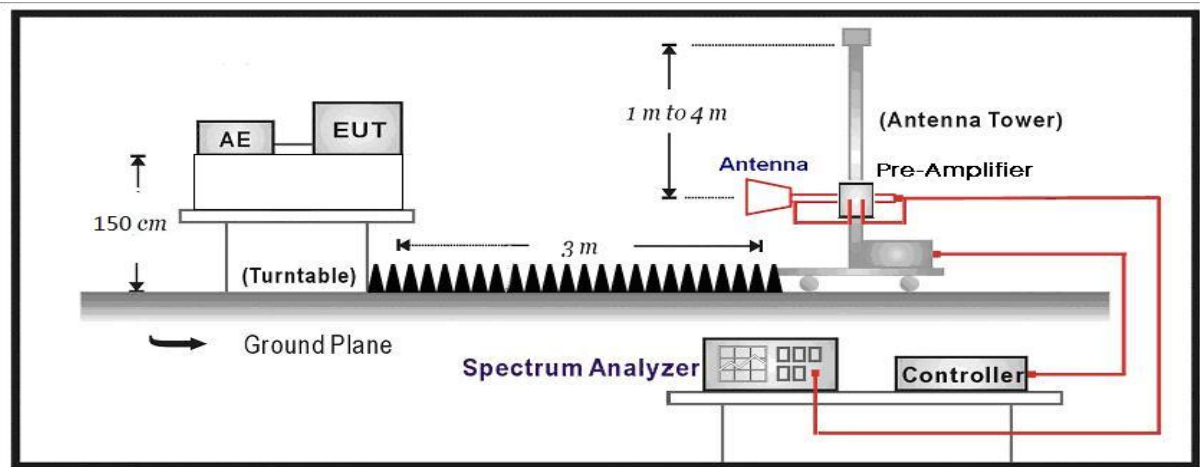

### 4.3. Limit

#### For FCC

Restricted Bands of operation			
Frequency (MHz)	Frequency (MHz)	Frequency (MHz)	Frequency (GHz)
0.090 – 0.110	16.42 – 16.423	399.9 – 410	4.5 – 5.15
0.495 – 0.505	16.69475 – 16.69525	608 – 614	5.35 – 5.46
2.1735 – 2.1905	16.80425 – 16.80475	960 – 1240	7.25 – 7.75
4.125 – 4.128	25.5 – 25.67	1300 – 1427	8.025 – 8.5
4.17725 – 4.17775	37.5 – 38.25	1435 – 1626.5	9.0 – 9.2
4.20725 – 4.20775	73 – 74.6	1645.5 – 1646.5	9.3 – 9.5
6.215 – 6.218	74.8 – 75.2	1660 – 1710	10.6 – 12.7
6.26775 – 6.26825	108 – 121.94	1718.8 – 1722.2	13.25 – 13.4
6.31175 – 6.31225	123 – 138	2200 – 2300	14.47 – 14.5
8.291 – 8.294	149.9 – 150.05	2310 – 2390	15.35 – 16.2
8.362 – 8.366	156.52475 – 156.52525	2483.5 – 2500	17.7 – 21.4
8.37625 – 8.38675	156.7 – 156.9	2690 – 2900	22.01 – 23.12
8.81425 – 8.81475	162.0125 – 167.17	3260 – 3267	23.6 – 24.0
12.29 – 12.293	167.72 – 173.2	3332 – 3339	31.2 – 31.8
12.51975 – 12.52025	240 – 285	3345.8 – 3358	36.43 – 36.5
12.57675 – 12.57725	322 – 335.4	3600 – 4400	
13.36 – 13.41			

**For IC:**

Restricted Bands of operation			
Frequency (MHz)	Frequency (MHz)	Frequency (MHz)	Frequency (GHz)
0.090-0.110	13.36-13.41	1645.5-1646.5	9.0-9.2
2.1735-2.1905	16.42-16.423	1660-1710	9.3-9.5
3.020-3.026	16.69475-16.69525	1718.8-1722.2	10.6-12.7
4.125-4.128	16.80425-16.80475	2200-2300	13.25-13.4
4.17725-4.17775	25.5-25.67	2310-2390	14.47-14.5
4.20725-4.20775	37.5-38.25	2655-2900	15.35-16.2
5.677-5.683	73-74.6	3260-3267	17.7-21.4
6.215-6.218	74.8-75.2	3332-3339	22.01-23.12
6.26775-6.26825	108-138	3345.8-3358	23.6-24.0
6.31175-6.31225	156.52475-156.52525	3500-4400	31.2-31.8
8.291-8.294	156.7-156.9	4500-5150	36.43-36.5
8.362-8.366	240-285	5350-5460	Above 38.6
8.37625-8.38675	322-335.4	7250-7750	
8.41425-8.41475	399.9-410	8025-8500	
12.29-12.293	608-614		
12.51975-12.52025	960-1427		
12.57675-12.57725	1435-1626.5		

Restricted Band Emissions Limit			
Frequency (MHz)	Field strength ( $\mu$ V/m)	Field strength (dB $\mu$ V/m)	Measurement distance (m)
0.009 - 0.49	2400/F(kHz)	48.5 – 13.8	300 <sub>(Note 1)</sub>
0.49 - 1.705	24000/F(kHz)	33.8 - 23	30 <sub>(Note 1)</sub>
1.705 - 30	30	29.5	30 <sub>(Note 1)</sub>
30 - 88	100	40	3 <sub>(Note 2)</sub>
88 - 216	150	43.5	3 <sub>(Note 2)</sub>
216 - 960	200	46	3 <sub>(Note 2)</sub>
Above 960	500	54	3 <sub>(Note 2)</sub>

Note 1: At frequencies below 30 MHz, measurements may be performed at a distance closer than that specified in the regulations; however, an attempt should be made to avoid making measurements in the near field. Pending the development of an appropriate measurement procedure for measurements performed below 30 MHz, when performing measurements at a closer distance than specified, the results shall be extrapolated to the specified distance by either making measurements at a minimum of two distances on at least one radial to determine the proper extrapolation factor or by using the square of an inverse linear distance extrapolation factor (40 dB/decade).



Note 2: At frequencies at or above 30 MHz, measurements may be performed at a distance other than what is specified provided: measurements are not made in the near field except where it can be shown that near field measurements are appropriate due to the characteristics of the device; and it can be demonstrated that the signal levels needed to be measured at the distance employed can be detected by the measurement equipment. Measurements shall not be performed at a distance greater than 30 meters unless it can be further demonstrated that measurements at a distance of 30 meters or less are impractical. When performing measurements at a distance other than that specified, the results shall be extrapolated to the specified distance using an extrapolation factor of 20 dB/decade (inverse linear-distance for field strength measurements; inverse-linear-distance-squared for power density measurements).



#### 4.4. Test Procedure

Test Method			
	References Rule	Chapter	Description
<input type="checkbox"/>	ANSI C63.10	11.11	Emissions in non-restricted frequency bands
	<input type="checkbox"/> ANSI C63.10	11.11.2	Reference level measurement
	<input type="checkbox"/> ANSI C63.10	11.11.3	Emission level measurement
<input checked="" type="checkbox"/>	ANSI C63.10	11.12	Emissions in restricted frequency bands
	<input checked="" type="checkbox"/> ANSI C63.10	11.12.1	Radiated emission measurements
	<input checked="" type="checkbox"/> ANSI C63.10	11.12.2.7	Radiated spurious emission test
	<input checked="" type="checkbox"/> ANSI C63.10	6.4	Radiated emissions from unlicensed wireless devices below 30 MHz
	<input checked="" type="checkbox"/> ANSI C63.10	6.5	Radiated emissions from unlicensed wireless devices in the frequency range of 30 MHz to 1000 MHz
	<input checked="" type="checkbox"/> ANSI C63.10	6.6	Radiated emissions from unlicensed wireless devices above 1 GHz
	<input type="checkbox"/> ANSI C63.10	11.12.2.3	Quasi-peak measurement procedure
	<input type="checkbox"/> ANSI C63.10	11.12.2.4	Peak power measurement procedure
	<input type="checkbox"/> ANSI C63.10	11.12.2.5	Average power measurement procedures
	<input type="checkbox"/> ANSI C63.10	11.12.2.5.1	Trace averaging with continuous EUT transmission at full power
	<input type="checkbox"/> ANSI C63.10	11.12.2.5.2	Trace averaging across ON and OFF times of the EUT transmissions followed by duty cycle correction
	<input type="checkbox"/> ANSI C63.10	11.12.2.5.3	Reduced VBW averaging across ON and OFF times of the EUT transmissions with max hold

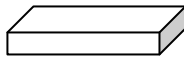
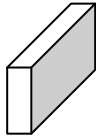
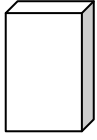
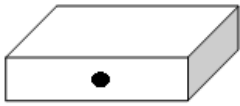
**4.5. EUT test Axis definition**

Item	Emissions in restricted frequency bands			
Device Category	<input checked="" type="checkbox"/>	Fixed position use		
	<input type="checkbox"/>	Mobile position use		
Test mode	Mode 1~4			
Test method	<input checked="" type="checkbox"/>	Radiated		
		X Axis	Y Axis	Z Axis
				
		Worst Axis <input checked="" type="checkbox"/>	Worst Axis <input type="checkbox"/>	Worst Axis <input type="checkbox"/>
	<input type="checkbox"/>	Conducted		
	<input type="checkbox"/>	Chain 1		
				
	<input type="checkbox"/>	Chain 1	Chain 2	
				
	<input type="checkbox"/>	Chain 1	Chain 2	Chain 3
				

### 4.6. Test Result

Product Name	: Cassia Bluetooth Router	Power	: AC 120V / 60Hz
Test Mode	: Mode 1	Test Site	: AC-5
Test Date	: 2017.5.20		

CH	Antenna Polarity	Frequency (MHz)	Reading Level (dB $\mu$ V)	Factor (dB)	Measured Level (dB $\mu$ V/m)	Limit (dB $\mu$ V/m)	Over Limit (dB)	Detector
1	H	4824.0	34.0	8.0	42.0	54(note3)	-12.0	PK
	H	7236.0	32.4	12.9	45.3	54(note3)	-8.7	PK
	H	9648.0	30.2	16.2	46.4	54(note3)	-7.6	PK
	V	4824.0	33.2	8.0	41.2	54(note3)	-12.8	PK
	V	7236.0	32.2	12.9	45.1	54(note3)	-8.9	PK
	V	9648.0	29.6	16.2	45.8	54(note3)	-8.2	PK
6	H	4874.0	34.0	8.1	42.1	54(note3)	-11.9	PK
	H	7312.0	31.8	12.6	44.4	54(note3)	-9.6	PK
	H	9748.0	30.8	16.1	46.9	54(note3)	-7.1	PK
	V	4874.0	34.2	8.1	42.3	54(note3)	-11.7	PK
	V	7312.0	31.4	12.6	44.0	54(note3)	-10.0	PK
	V	9748.0	30.3	16.1	46.4	54(note3)	-7.6	PK
11	H	4924.0	34.6	8.2	42.8	54(note3)	-11.2	PK
	H	7386.0	32.2	12.6	44.8	54(note3)	-9.2	PK
	H	9848.0	29.9	16.5	46.4	54(note3)	-7.6	PK
	V	4924.0	35.1	8.2	43.3	54(note3)	-10.7	PK
	V	7386.0	33.6	12.6	46.2	54(note3)	-7.8	PK
	V	9848.0	29.8	16.5	46.3	54(note3)	-7.7	PK

Note: 1. Measure Level = Reading Level + Factor.

Note: 2. The test frequency range, 9kHz~30MHz, 18GHz~25GHz, both of the worst case are at least 6dB below the limits, therefore no data appear in the report.

Note: 3. This limit applies for using average detector, if the test result on peak is lower than average limit, then average measurement needn't be performed.

Note: 4. The RBW setting, see Clause 6.6.

Product Name	: Cassia Bluetooth Router	Power	: AC 120V / 60Hz
Test Site	: Mode 2	Test Site	: AC-5
Test Date	: 2017.05.20		

CH	Antenna Polarity	Frequency (MHz)	Reading Level (dB μV)	Factor (dB)	Measured Level (dB μV/m)	Limit (dB μV/m)	Over Limit (dB)	Detector
1	H	4824.0	34.4	8.0	42.4	54(note3)	-11.6	PK
	H	7236.0	33.8	12.9	46.7	54(note3)	-7.3	PK
	H	9648.0	30.4	16.2	46.6	54(note3)	-7.4	PK
	V	4824.0	33.9	8.0	41.9	54(note3)	-12.1	PK
	V	7236.0	31.4	12.9	44.3	54(note3)	-9.7	PK
	V	9648.0	30.5	16.2	46.7	54(note3)	-7.3	PK
6	H	4874.0	34.4	8.1	42.5	54(note3)	-11.5	PK
	H	7312.0	32.0	12.6	44.6	54(note3)	-9.4	PK
	H	9748.0	30.3	16.1	46.4	54(note3)	-7.6	PK
	V	4874.0	33.6	8.1	41.7	54(note3)	-12.3	PK
	V	7312.0	30.8	12.6	43.4	54(note3)	-10.6	PK
	V	9748.0	30.6	16.1	46.7	54(note3)	-7.3	PK
11	H	4924.0	35.1	8.2	43.3	54(note3)	-10.7	PK
	H	7386.0	33.5	12.6	46.1	54(note3)	-7.9	PK
	H	9848.0	30.3	16.5	46.8	54(note3)	-7.2	PK
	V	4924.0	34.8	8.2	43.0	54(note3)	-11.0	PK
	V	7386.0	35.1	12.6	47.7	54(note3)	-6.3	PK
	V	9848.0	30.5	16.5	47.0	54(note3)	-7.0	PK

Note: 1. Measure Level = Reading Level + Factor.

Note: 2. The test frequency range, 9kHz~30MHz, 18GHz~25GHz, both of the worst case are at least 6dB below the limits, therefore no data appear in the report.

Note: 3. This limit applies for using average detector, if the test result on peak is lower than average limit, then average measurement needn't be performed.

Note: 4. The RBW setting, see Clause 6.6.

Product Name	: Cassia Bluetooth Router	Power	: AC 120V / 60Hz
Test Site	: Mode 3	Test Site	: AC-5
Test Date	: 2017.05.20		

CH	Antenna Polarity	Frequency (MHz)	Reading Level (dB μV)	Factor (dB)	Measured Level (dB μV/m)	Limit (dB μV/m)	Over Limit (dB)	Detector
1	H	4824.0	33.4	8.0	41.4	54(note3)	-12.6	PK
	H	7236.0	31.5	12.9	44.4	54(note3)	-9.6	PK
	H	9648.0	30.5	16.2	46.7	54(note3)	-7.3	PK
	V	4824.0	35.6	8.0	43.6	54(note3)	-10.4	PK
	V	7236.0	32.4	12.9	45.3	54(note3)	-8.7	PK
	V	9648.0	30.7	16.2	46.9	54(note3)	-7.1	PK
6	H	4874.0	35.6	8.1	43.7	54(note3)	-10.3	PK
	H	7312.0	34.9	12.6	47.5	54(note3)	-6.5	PK
	H	9748.0	33.2	16.1	49.3	54(note3)	-4.7	PK
	V	4874.0	35.1	8.1	43.2	54(note3)	-10.8	PK
	V	7312.0	34.7	12.6	47.3	54(note3)	-6.7	PK
	V	9748.0	32.3	16.1	48.4	54(note3)	-5.6	PK
11	H	4924.0	34.8	8.2	43.0	54(note3)	-11.0	PK
	H	7386.0	31.8	12.6	44.4	54(note3)	-9.6	PK
	H	9848.0	30.4	16.5	46.9	54(note3)	-7.1	PK
	V	4924.0	36.1	8.2	44.3	54(note3)	-9.7	PK
	V	7386.0	35.3	12.6	47.9	54(note3)	-6.1	PK
	V	9848.0	34.1	16.5	50.6	54(note3)	-3.4	PK

Note: 1. Measure Level = Reading Level + Factor.

Note: 2. The test frequency range, 9kHz~30MHz, 18GHz~25GHz, both of the worst case are at least 6dB below the limits, therefore no data appear in the report.

Note: 3. This limit applies for using average detector, if the test result on peak is lower than average limit, then average measurement needn't be performed.

Note: 4. The RBW setting, see Clause 6.6.

Product Name	: Cassia Bluetooth Router	Power	: AC 120V / 60Hz
Test Site	: Mode 4	Test Site	: AC-5
Test Date	: 2017.05.20		

CH	Antenna Polarity	Frequency (MHz)	Reading Level (dB $\mu$ V)	Factor (dB)	Measured Level (dB $\mu$ V/m)	Limit (dB $\mu$ V/m)	Over Limit (dB)	Detector
3	H	4844.0	34.1	8.3	42.4	54(note3)	-11.6	PK
	H	7266.0	32.7	12.7	45.4	54(note3)	-8.6	PK
	H	9688.0	31.1	15.9	47.0	54(note3)	-7.0	PK
	V	4844.0	35.3	8.3	43.6	54(note3)	-10.4	PK
	V	7266.0	33.9	12.7	46.6	54(note3)	-7.4	PK
	V	9688.0	31.4	15.9	47.3	54(note3)	-6.7	PK
6	H	4874.0	34.5	8.1	42.6	54(note3)	-11.4	PK
	H	7311.0	34.6	12.6	47.2	54(note3)	-6.8	PK
	H	9748.0	32.7	16.1	48.8	54(note3)	-5.2	PK
	V	4874.0	36.5	8.1	44.6	54(note3)	-9.4	PK
	V	7311.0	33.2	12.6	45.8	54(note3)	-8.2	PK
	V	9748.0	32.0	16.1	48.1	54(note3)	-5.9	PK
9	H	4904.0	35.1	8.2	43.3	54(note3)	-10.7	PK
	H	7356.0	31.8	13.2	45.0	54(note3)	-9.0	PK
	H	9808.0	29.5	16.1	45.6	54(note3)	-8.4	PK
	V	4904.0	34.7	8.2	42.9	54(note3)	-11.1	PK
	V	7356.0	31.8	13.2	45.0	54(note3)	-9.0	PK
	V	9808.0	30.1	16.1	46.2	54(note3)	-7.8	PK

Note: 1. Measure Level = Reading Level + Factor.

Note: 2. The test frequency range, 9kHz~30MHz, 18GHz~25GHz, both of the worst case are at least 6dB below the limits, therefore no data appear in the report.

Note: 3. This limit applies for using average detector, if the test result on peak is lower than average limit, then average measurement needn't be performed.

Note: 4. The RBW setting, see Clause 6.6.

Product Name	: Cassia Bluetooth Router	Power	: AC 120V/60Hz
Test Mode	: Transmit Simultaneously (2G+WIFI+BT)-worst data	Test Site	: AC-5
Test Date	: 2017.05.09		

Transmit at 2462MHz by 802.11n20 and at 2402MHz by BLE.

Antenna	Frequency (MHz)	Reading Level (dBuV/m)	Factor (dB)	Measure Level (dBuV/m)	Limit (dBuV/m)	Over Limit (dB)	Detector
H	4924.000	33.893	8.2	42.093	54(note3)	-11.907	PK
H	7386.000	30.902	12.6	43.502	54(note3)	-10.498	PK
H	9848.000	30.074	16.5	46.574	54(note3)	-7.426	PK
V	4924.000	35.142	8.2	43.342	54(note3)	-10.658	PK
V	7386.000	34.784	12.6	47.384	54(note3)	-6.616	PK
V	9848.000	33.431	16.5	49.931	54(note3)	-4.069	PK
H	4804.000	44.533	6.087	50.620	54(Note3)	-3.38	PK
H	7206.000	36.114	10.232	46.346	54(Note3)	-7.654	PK
H	9608.000	34.457	12.559	47.016	54(Note3)	-6.984	PK
V	4804.000	45.867	6.087	51.954	54(Note3)	-2.046	PK
V	7206.000	37.206	10.232	47.438	54(Note3)	-6.562	PK
V	9608.000	34.732	12.559	47.291	54(Note3)	-6.709	PK

Note: We have evaluated 2G, WiFi,Bluetooth transmit simultaneously, shown in the report is the worst data.

**The worst case of Radiated Emission below 1GHz:**

Site: AC2	Time: 2017/03/16
Limit: FCC_Part15.109_RE(3m)_ClassB	Margin: 0
Probe: AC2_CBL6112_0726	Polarity: Horizontal
EUT: Cassia Bluetooth Router	Power: AC 120V/60Hz
Note: WiFi + BT	

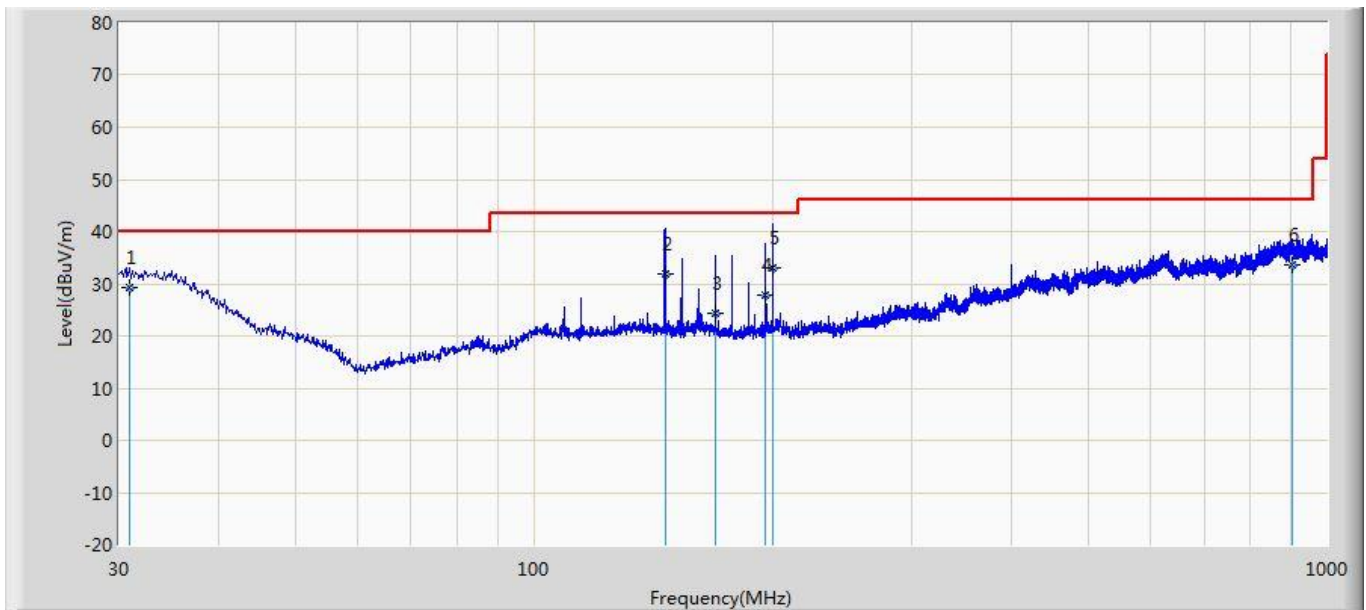

No	Mark	Frequency (MHz)	Measure Level (dBuV/m)	Reading Level (dBuV)	Over Limit (dB)	Limit (dBuV/m)	Probe (dB/m)	Cable (dB)	Amp (dB)	Ant Pos (cm)	Table Pos (deg)	Type
1		30.970	29.347	33.600	-10.653	40.000	18.237	0.610	23.100	100	41	QP
2		146.440	31.804	42.800	-11.696	43.500	10.714	1.310	23.020	200	51	QP
3		169.437	24.360	36.400	-19.140	43.500	9.617	1.410	23.067	100	208	QP
4		196.113	27.941	40.200	-15.559	43.500	9.383	1.520	23.163	300	47	QP
5	*	199.992	33.063	45.214	-10.437	43.500	9.489	1.540	23.180	100	156	QP
6		902.237	33.540	32.500	-12.460	46.000	20.518	3.310	22.788	200	31	QP

**Note:**

- " \* ", means this data is the worst emission level.
- Measurement Level = Reading Level + Factor(Probe+Cable-Amp).



Site: AC2	Time: 2017/03/16
Limit: FCC_Part15.109_RE(3m)_ClassB	Margin: 0
Probe: AC2_CBL6112_0726	Polarity: Vertical
EUT: Cassia Bluetooth Router	Power: AC 120V/60Hz
Note: WiFi + BT	

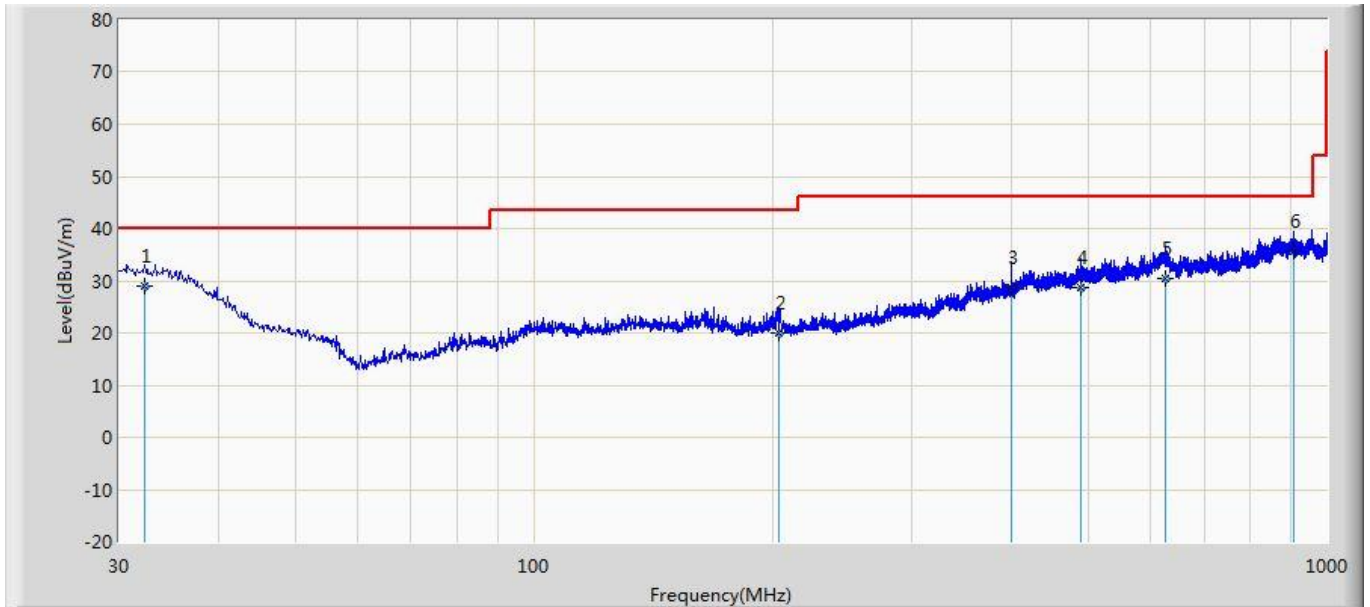

No	Mark	Frequency (MHz)	Measure Level (dBuV/m)	Reading Level (dBuV)	Over Limit (dB)	Limit (dBuV/m)	Probe (dB/m)	Cable (dB)	Amp (dB)	Ant Pos (cm)	Table Pos (deg)	Type
1		32.304	29.064	34.100	-10.936	40.000	17.464	0.624	23.124	100	59	QP
2		203.994	20.140	32.400	-23.360	43.500	9.380	1.550	23.190	200	144	QP
3		400.055	28.785	33.600	-17.215	46.000	16.000	2.215	23.030	100	79	QP
4		490.508	28.588	31.300	-17.412	46.000	17.648	2.400	22.760	100	245	QP
5		624.974	30.404	31.200	-15.596	46.000	19.000	2.740	22.536	200	54	QP
6	*	907.607	35.548	34.400	-10.452	46.000	20.561	3.320	22.733	200	165	QP

**Note:**

1. " \* ", means this data is the worst emission level.
2. Measurement Level = Reading Level + Factor(Probe+Cable-Amp).

## 5. Emissions in non-restricted frequency bands

### 5.1. Test Equipment

Occupied Bandwidth / TR-8					
Instrument	Manufacturer	Type No.	Serial No.	Cal. Date	Cal. Due Date
Spectrum Analyzer	Agilent	N9010A	MY48030494	2017.02.04	2018.02.04
EXA Spectrum Analyzer	Keysight	N9010A	MY55370495	2017.04.09	2018.04.09
MXA Signal Analyzer	Keysight	N9020A	MY56060147	2017.04.09	2018.04.09
Temperature/Humidity Meter	zhichen	ZC1-2	TR8-TH	2017.04.10	2018.04.10

Note: All equipments are calibrated with traceable calibrations. Each calibration is traceable to the national or international standards.

### 5.2. Test Setup

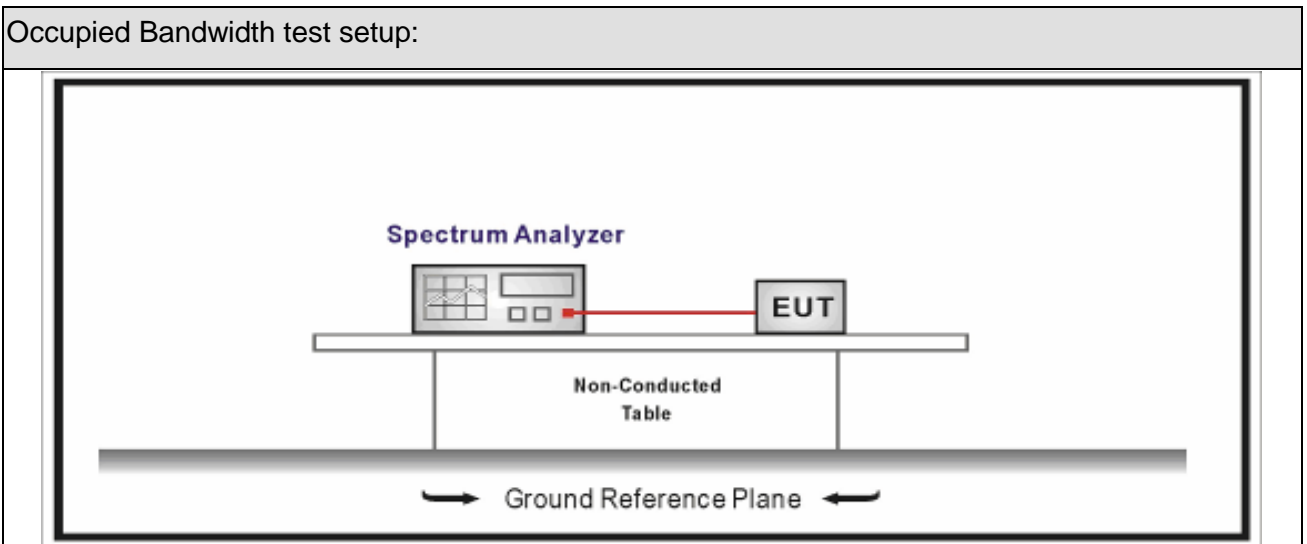



### 5.3. Limit

Un-Restricted Band Emissions Limit	
RF Output power (Detection methods)	Limit(dB)
RF Output power(Average detector)	30c(Note1)
RF Output power(PK detector)	20c(Note2)
<p>Note 1: If maximum conducted (average) output power was used to demonstrate compliance as described in 9.2, then the peak power in any 100 kHz bandwidth outside of the authorized frequency band shall be attenuated by at least 30 dB relative to the maximum in-band peak PSD level in 100 kHz (i.e., 30 dBc).</p> <p>Note 2: If the maximum peak conducted output power procedure was used, then the peak output power measured in any 100 kHz bandwidth outside of the authorized frequency band shall be attenuated by at least 20 dB relative to the maximum in-band peak PSD level in 100 kHz (i.e., 20 dBc).</p>	

**5.4. Test Procedure**

Test Method			
	References Rule	Chapter	Description
<input checked="" type="checkbox"/>	ANSI C63.10	11.11	Emissions in non-restricted frequency bands
	<input checked="" type="checkbox"/> ANSI C63.10	11.11.2	Reference level measurement
	<input checked="" type="checkbox"/> ANSI C63.10	11.11.3	Emission level measurement
<input type="checkbox"/>	ANSI C63.10	11.12	Emissions in restricted frequency bands
	<input type="checkbox"/> ANSI C63.10	11.12.1	Radiated emission measurements
	<input type="checkbox"/> ANSI C63.10	11.12.2.7	Radiated spurious emission test
<input type="checkbox"/>	ANSI C63.10	6.4	Radiated emissions from unlicensed wireless devices below 30 MHz
<input type="checkbox"/>	ANSI C63.10	6.5	Radiated emissions from unlicensed wireless devices in the frequency range of 30 MHz to 1000 MHz
<input type="checkbox"/>	ANSI C63.10	6.6	Radiated emissions from unlicensed wireless devices above 1 GHz
	<input checked="" type="checkbox"/> ANSI C63.10	11.12.2	Antenna-port conducted measurements
	<input type="checkbox"/> ANSI C63.10	11.12.2.3	Quasi-peak measurement procedure
	<input checked="" type="checkbox"/> ANSI C63.10	11.12.2.4	Peak power measurement procedure
	<input type="checkbox"/> ANSI C63.10	11.12.2.5	Average power measurement procedures
	<input type="checkbox"/> ANSI C63.10	11.12.2.5.1	Trace averaging with continuous EUT transmission at full power
	<input type="checkbox"/> ANSI C63.10	11.12.2.5.2	Trace averaging across ON and OFF times of the EUT transmissions followed by duty cycle correction
	<input type="checkbox"/> ANSI C63.10	11.12.2.5.3	Reduced VBW averaging across ON and OFF times of the EUT transmissions with max hold

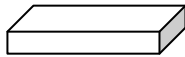
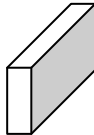
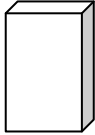
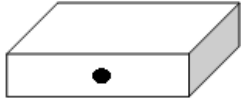
**5.5. EUT test Axis definition**

Item	Emissions in non-restricted frequency bands			
Device Category	<input checked="" type="checkbox"/>	Fixed position use		
	<input type="checkbox"/>	Mobile position use		
Test mode	Mode 1 ~ Mode 4			
Test method	<input type="checkbox"/>	Radiated		
		X Axis	Y Axis	Z Axis
				
		Worst Axis <input type="checkbox"/>	Worst Axis <input type="checkbox"/>	Worst Axis <input type="checkbox"/>
	<input checked="" type="checkbox"/>	Conducted		
	<input checked="" type="checkbox"/>	Chain 0		
				
	<input type="checkbox"/>	Chain 0	Chain 1	
				
	<input type="checkbox"/>	Chain 0	Chain 1	Chain 2
				

**5.6. Test Result**

Product Name	: Cassia Bluetooth Router	Power	: AC 120V / 60Hz
Test Mode	: Mode1~4	Test Site	: TR8
Test Date	: 2017.05.22		

**Antenna #0**

Mode	Channel	Test Frequency (MHz)	In-Band PSD[a] (dBm/100kHz)	Frequency (MHz)	Out-Band PSD[b] (dBm/100kHz)	[a]-[b] (dB)	Limit (dB)	Result
1	01	2412	17.86	2400	-40.536	58.396	>30	Pass
1	11	2462	17.86	2483.5	-43.338	61.198	>30	Pass
2	01	2412	17.54	2400	-27.531	45.071	>30	Pass
2	11	2462	17.54	2483.5	-43.129	60.669	>30	Pass
3	01	2412	17.16	2400	-28.176	45.336	>30	Pass
3	11	2462	17.16	2483.5	-43.322	60.482	>30	Pass
4	03	2422	10.73	2400	-28.194	38.924	>30	Pass
4	09	2452	10.73	2483.5	-46.518	57.248	>30	Pass

## 6. Radiated Emission Band Edge

### 6.1. Test Equipment

Radiated Emission(Above 1GHz) / AC-5					
Instrument	Manufacturer	Type No.	Serial No.	Cal. Date	Cal. Due Date
EMI Receiver	Agilent	N9038A	MY51210196	2016.07.16	2017.07.16
Pre-Amplifier	Miteq	NSP1800-25	1364185	2017.05.03	2018.05.03
DRG Horn Antenna	ETS-Lindgren	3117	00167055	2016.07.12	2017.07.12
Broad-Band Horn Antenna	Schwarzbeck	BBHA9170	294	2016.09.18	2017.09.18
Coaxial Cable	Huber+Suhner	SUCOFLEX 106	AC5-C1	2017.02.28	2018.02.28
Coaxial Cable	Huber+Suhner	SUCOFLEX 106	AC5-C2	2017.02.28	2018.02.28
Temperature/Humidity Meter	Zhichen	ZC1-2	AC5-TH	2017.01.05	2018.01.05
Note: All equipments are calibrated with traceable calibrations. Each calibration is traceable to the national or international standards.					

### 6.2. Test Setup

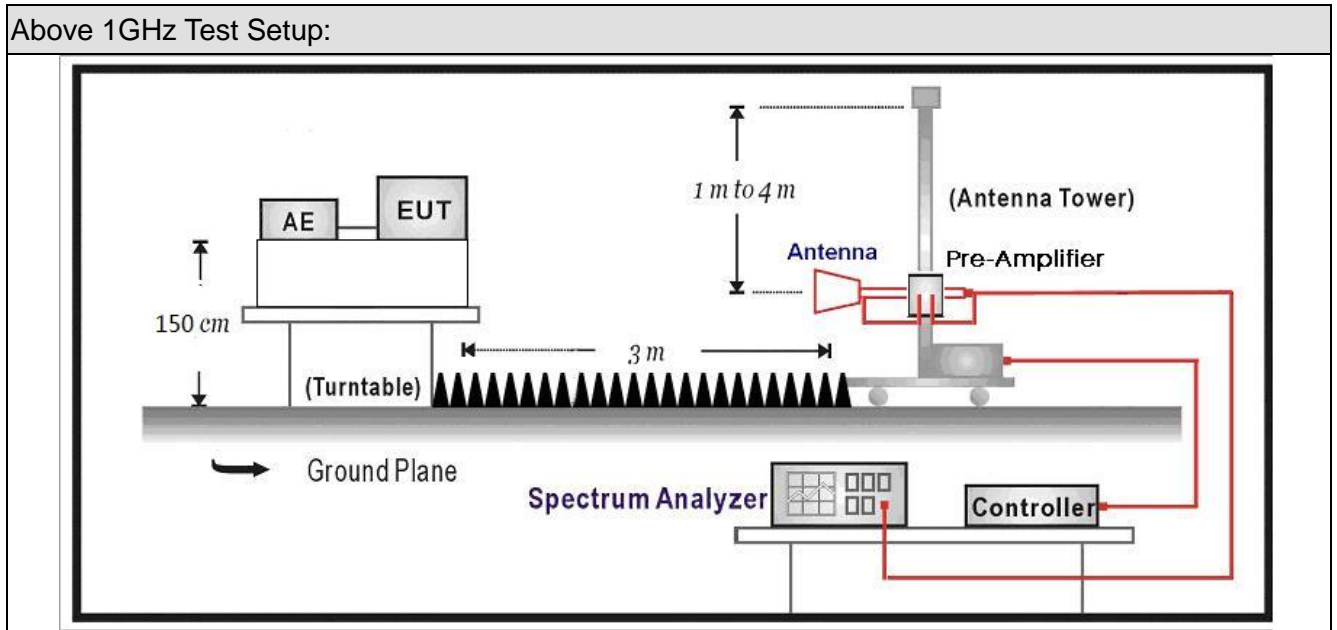

### 6.3. Limit

Band edge Limit				
Frequency bands (MHz)	Detector	Limit (dB $\mu$ V/m)	RBW (MHz)	Distance (m)
2310-2390	PK	74	1	3
2483.5-2500	AV	54	1	3



Note: The field strength of emissions appearing within these frequency bands shall not exceed the limits.



### 6.4. Test Procedure

Test Method			
	References Rule	Chapter	Description
<input checked="" type="checkbox"/>	ANSI C63.10	6.10	Band-edge testing
	<input checked="" type="checkbox"/> ANSI C63.10	6.10.5	Restricted-band band-edge measurements
	<input type="checkbox"/> ANSI C63.10	6.10.6	Marker-delta method
<input checked="" type="checkbox"/>	ANSI C63.10	11.12	Emissions in restricted frequency bands
	<input checked="" type="checkbox"/> ANSI C63.10	11.12.1	Radiated emission measurements
	<input checked="" type="checkbox"/> ANSI C63.10	11.12.2.7	Radiated spurious emission test
<input type="checkbox"/>	ANSI C63.10	6.4	Radiated emissions from unlicensed wireless devices below 30 MHz
<input type="checkbox"/>	ANSI C63.10	6.5	Radiated emissions from unlicensed wireless devices in the frequency range of 30 MHz to 1000 MHz
<input type="checkbox"/>	ANSI C63.10	6.6	Radiated emissions from unlicensed wireless devices above 1 GHz
	<input type="checkbox"/> ANSI C63.10	11.12.2.3	Quasi-peak measurement procedure
	<input checked="" type="checkbox"/> ANSI C63.10	11.12.2.4	Peak power measurement procedure
	<input checked="" type="checkbox"/> ANSI C63.10	11.12.2.5	Average power measurement procedures
	<input type="checkbox"/> ANSI C63.10	11.12.2.5.1	Trace averaging with continuous EUT transmission at full power
	<input type="checkbox"/> ANSI C63.10	11.12.2.5.2	Trace averaging across ON and OFF times of the EUT transmissions followed by duty cycle correction
	<input checked="" type="checkbox"/> ANSI C63.10	11.12.2.5.3	Reduced VBW averaging across ON and OFF times of the EUT transmissions with max hold

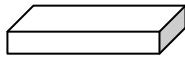
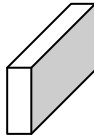
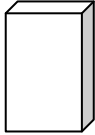
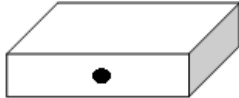
**6.5. EUT test definition**

Item	Emissions in non-restricted frequency bands			
Device Category	<input checked="" type="checkbox"/>	Fixed position use		
	<input type="checkbox"/>	Mobile position use		
Test mode	Mode 1~4			
Test method	<input checked="" type="checkbox"/>	Radiated		
		X Axis	Y Axis	Z Axis
				
		Worst Axis <input checked="" type="checkbox"/>	Worst Axis <input type="checkbox"/>	Worst Axis <input type="checkbox"/>
	<input type="checkbox"/>	Conducted		
	<input type="checkbox"/>	Chain 1		
				
	<input type="checkbox"/>	Chain 1	Chain 2	
				
	<input type="checkbox"/>	Chain 1	Chain 2	Chain 3
				

### 6.6. Duty Cycle

Test Mode	Tx On (ms)	Tx Off (ms)	VBW	Tx On + Tx Off (ms)	Duty Cycle
802.11b	12.16	0.1	82Hz	12.26	99.18%
802.11g	2.005	0.065	510HZ	2.070	96.86%
802.11n(20MHz)	1.865	0.07	560Hz	1.935	96.38%
802.11n(40MHz)	0.912	0.06	1.1KHz	0.972	93.83%

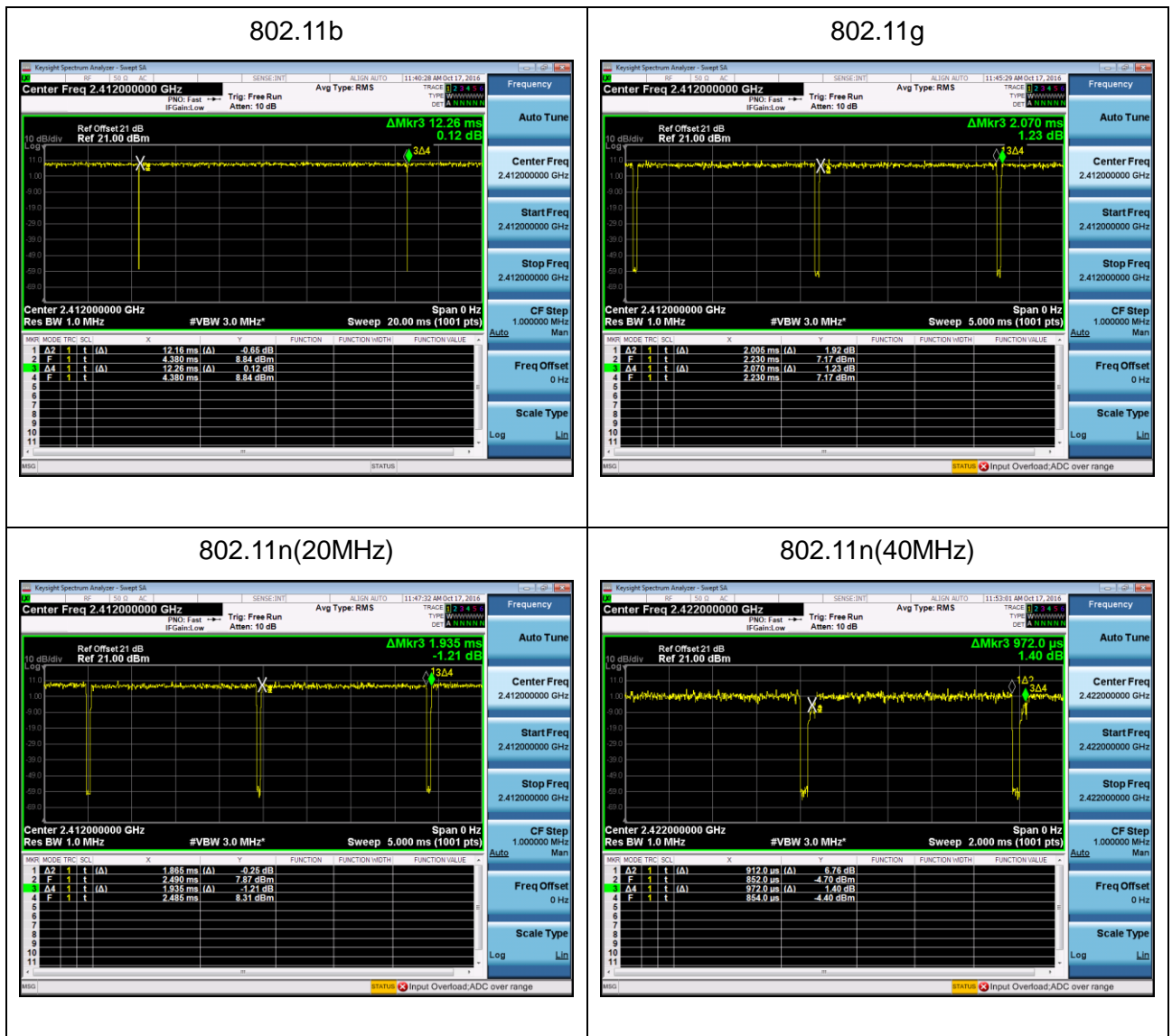

### 6.7. Test Result

Site: AC5	Time: 2017/05/18- 09:58
Limit: FCC_Part15.209_RE(3m)	Margin: 0
Probe: Horn_3117_00167055(1-18GHz)	Polarity: Horizontal
EUT:300Mbps Wireless N Nano Router	Power: AC 120V/60Hz
Note: Mode 1:Transmit at 2412MHz by 802.11B	

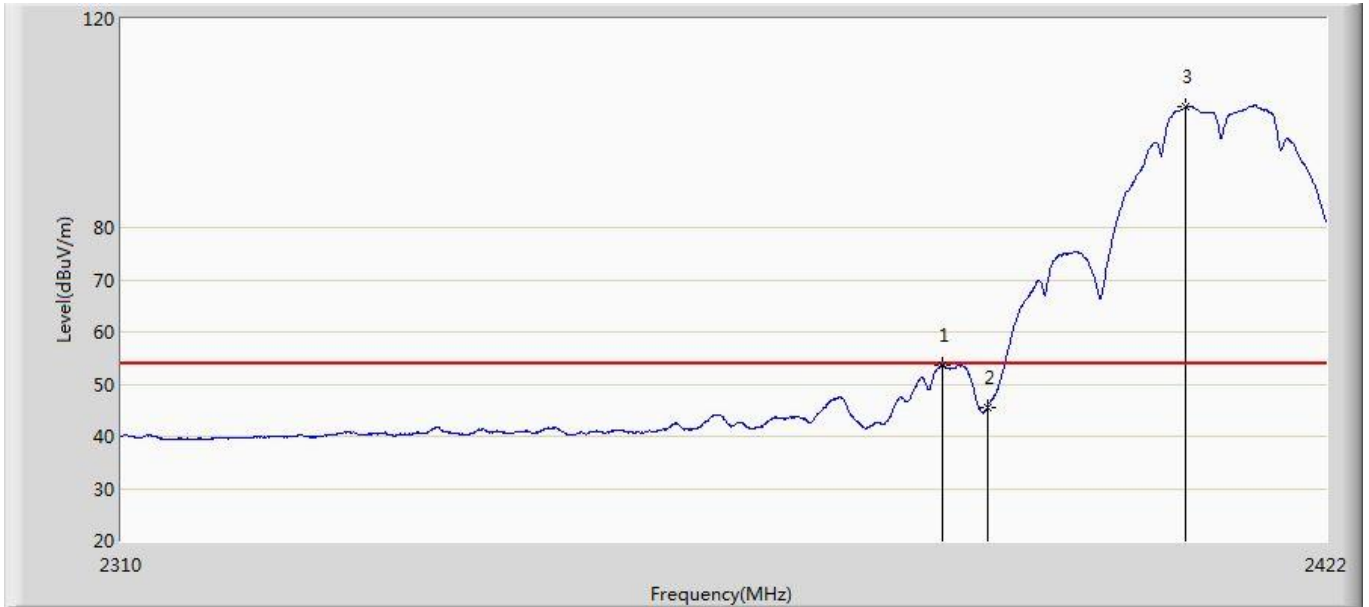

No	Mark	Frequency (MHz)	Measure Level (dBuV/m)	Reading Level (dBuV)	Over Limit (dB)	Limit (dBuV/m)	Factor (dB)	Type
1		2385.712	53.541	17.212	-0.459	54.000	36.329	AV
2		2390.000	45.645	9.315	-8.355	54.000	36.329	AV
3	*	2408.672	103.179	66.852	49.179	54.000	36.327	AV

Site: AC5	Time: 2017/05/18- 10:05
Limit: FCC_Part15.209_RE(3m)	Margin: 0
Probe: Horn_3117_00167055(1-18GHz)	Polarity: Horizontal
EUT:300Mbps Wireless N Nano Router	Power: AC 120V/60Hz
Note: Mode 1:Transmit at 2412MHz by 802.11B	

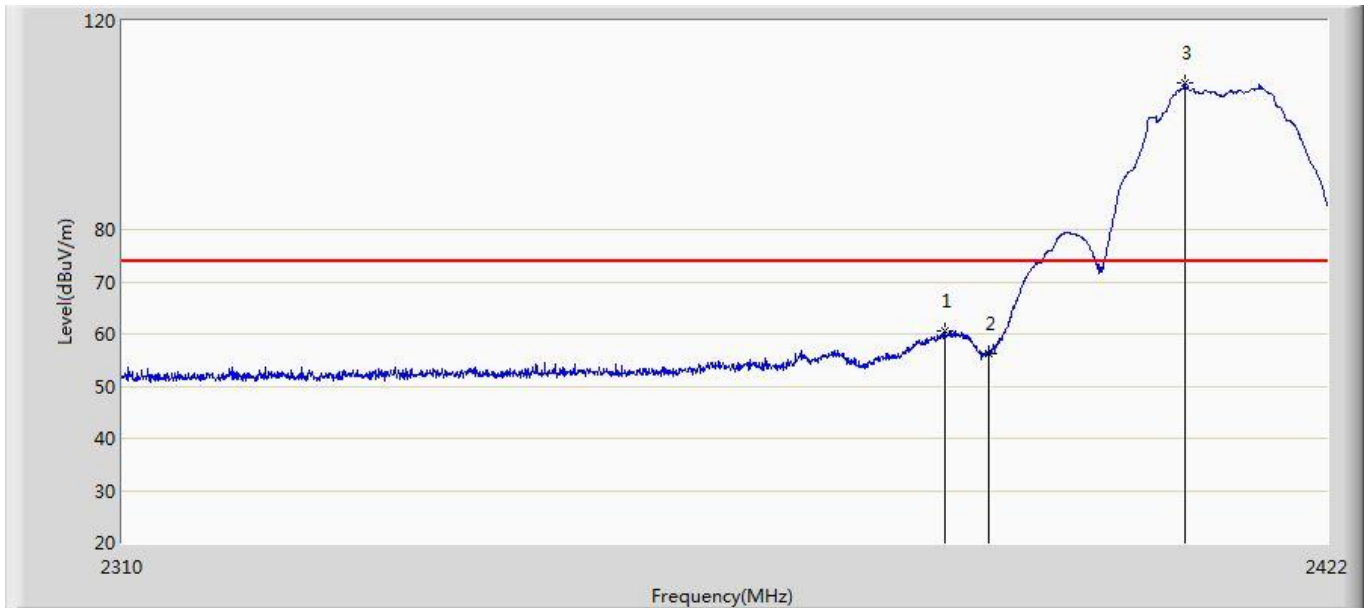

No	Mark	Frequency (MHz)	Measure Level (dBuV/m)	Reading Level (dBuV)	Over Limit (dB)	Limit (dBuV/m)	Factor (dB)	Type
1		2385.880	60.679	24.350	-13.321	74.000	36.329	PK
2		2390.000	56.300	19.970	-17.700	74.000	36.329	PK
3	*	2408.504	108.017	71.690	34.017	74.000	36.327	PK

Site: AC5	Time: 2017/05/18- 10:07
Limit: FCC_Part15.209_RE(3m)	Margin: 0
Probe: Horn_3117_00167055(1-18GHz)	Polarity: Vertical
EUT:300Mbps Wireless N Nano Router	Power: AC 120V/60Hz
Note: Mode 1:Transmit at 2412MHz by 802.11B	

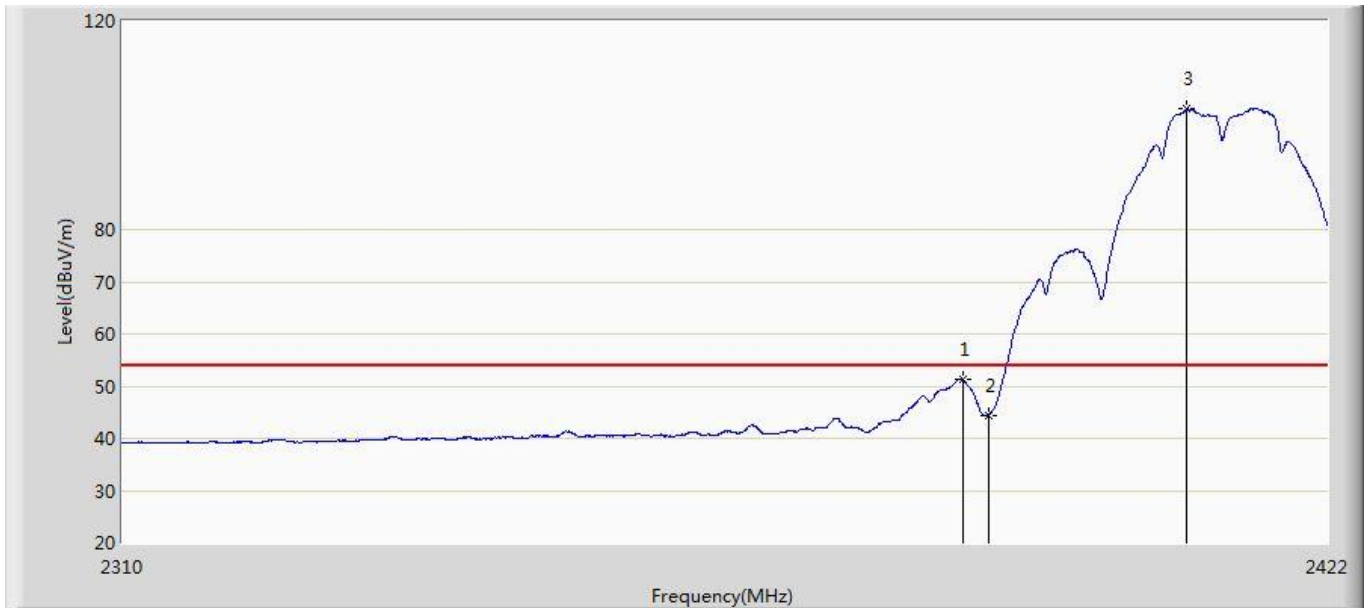

No	Mark	Frequency (MHz)	Measure Level (dBuV/m)	Reading Level (dBuV)	Over Limit (dB)	Limit (dBuV/m)	Factor (dB)	Type
1		2387.560	51.218	14.889	-2.782	54.000	36.329	AV
2		2390.000	44.399	8.069	-9.601	54.000	36.329	AV
3	*	2408.728	103.085	66.758	49.085	54.000	36.327	AV

Site: AC5	Time: 2017/05/18- 10:09
Limit: FCC_Part15.209_RE(3m)	Margin: 0
Probe: Horn_3117_00167055(1-18GHz)	Polarity: Vertical
EUT:300Mbps Wireless N Nano Router	Power: AC 120V/60Hz
Note: Mode 1:Transmit at 2412MHz by 802.11B	

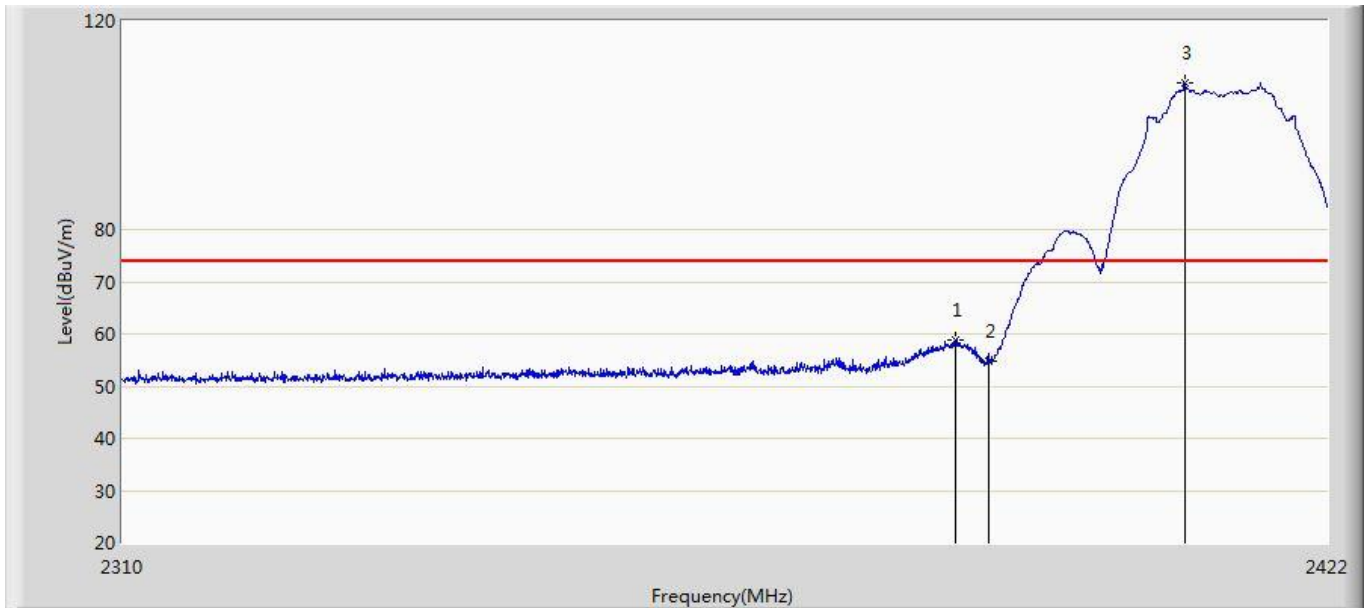

No	Mark	Frequency (MHz)	Measure Level (dBuV/m)	Reading Level (dBuV)	Over Limit (dB)	Limit (dBuV/m)	Factor (dB)	Type
1		2386.888	58.709	22.380	-15.291	74.000	36.329	PK
2		2390.000	54.671	18.341	-19.329	74.000	36.329	PK
3	*	2408.504	107.983	71.656	33.983	74.000	36.327	PK

Site: AC5	Time: 2017/07/07 - 10:31
Limit: FCC_Part15.209_RE(3m)	Margin: 0
Probe: Horn_3117_00167055(1-18GHz)	Polarity: Horizontal
EUT: 300Mbps Wireless N Nano Router	Power: AC 120V/60Hz
Note: Mode 1:Transmit at 2422MHz by 802.11B	

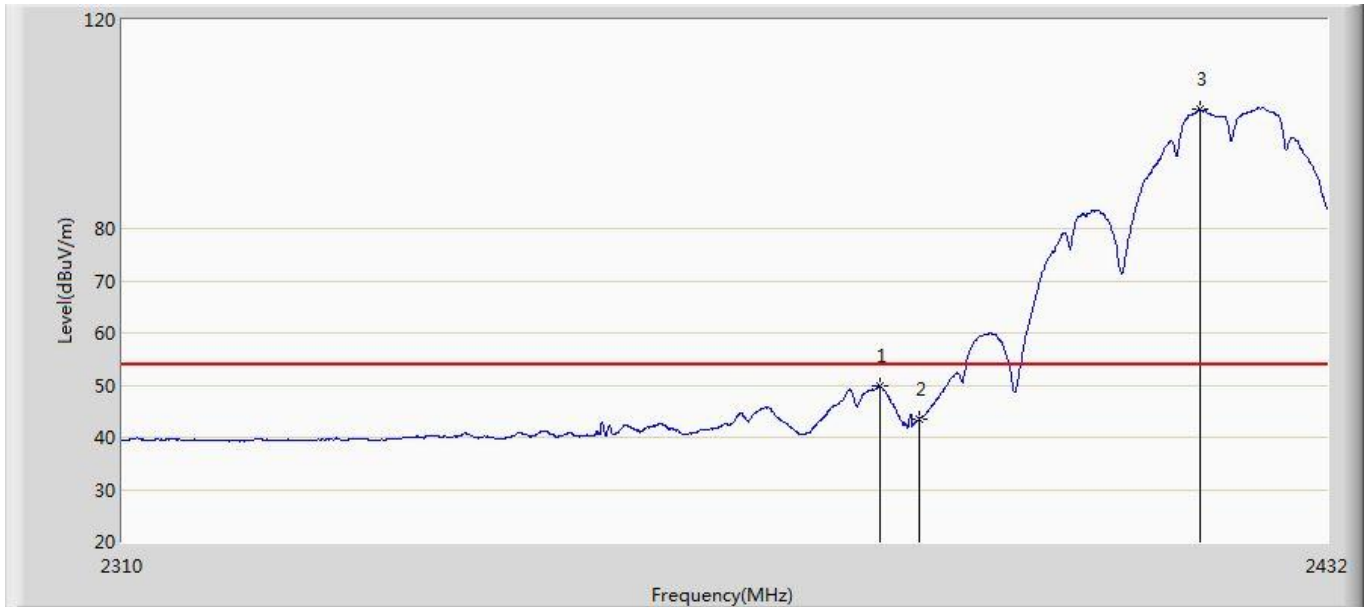

No	Mark	Frequency (MHz)	Measure Level (dBuV/m)	Reading Level (dBuV)	Over Limit (dB)	Limit (dBuV/m)	Factor (dB)	Type
1		2385.945	49.742	13.413	-4.258	54.000	36.329	AV
2		2390.000	43.520	7.190	-10.480	54.000	36.329	AV
3	*	2418.824	102.832	66.381	48.832	54.000	36.452	AV



Site: AC5	Time: 2017/07/07 - 10:56
Limit: FCC_Part15.209_RE(3m)	Margin: 0
Probe: Horn_3117_00167055(1-18GHz)	Polarity: Horizontal
EUT: 300Mbps Wireless N Nano Router	Power: AC 120V/60Hz
Note: Mode 1:Transmit at 2422MHz by 802.11B	

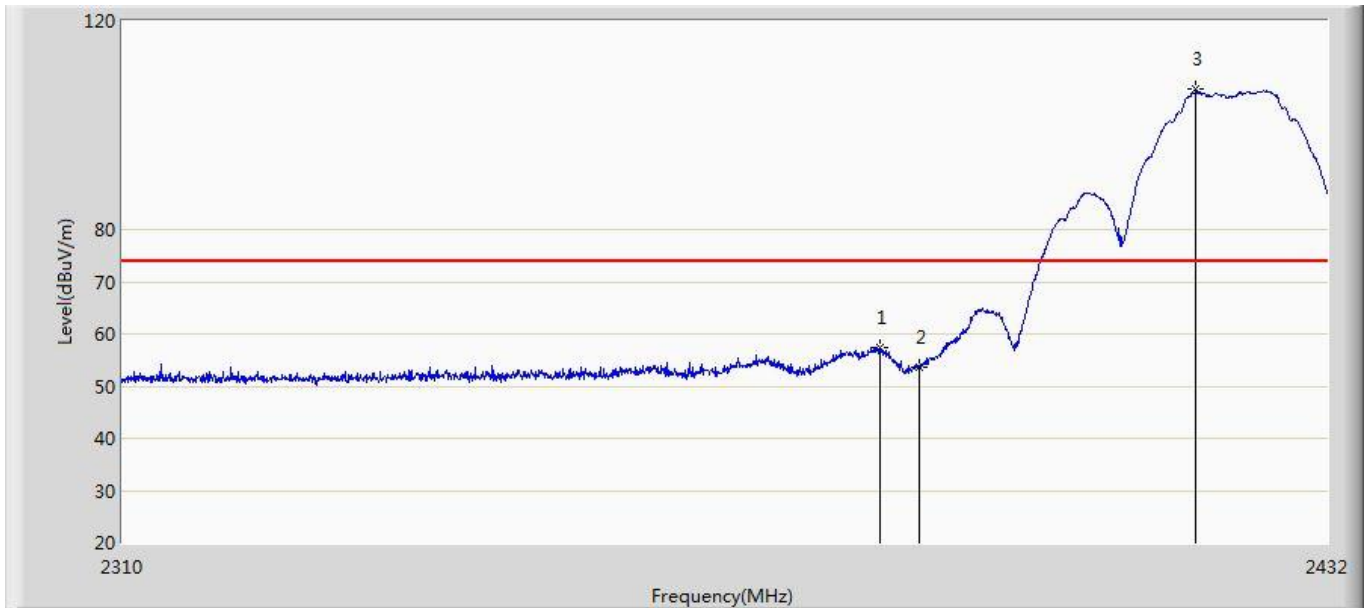

No	Mark	Frequency (MHz)	Measure Level (dBuV/m)	Reading Level (dBuV)	Over Limit (dB)	Limit (dBuV/m)	Factor (dB)	Type
1		2386.006	57.472	21.143	-16.528	74.000	36.329	PK
2		2390.000	53.670	17.340	-20.330	74.000	36.329	PK
3	*	2418.458	106.868	70.423	32.868	74.000	36.445	PK

Site: AC5	Time: 2017/07/07 - 11:03
Limit: FCC_Part15.209_RE(3m)	Margin: 0
Probe: Horn_3117_00167055(1-18GHz)	Polarity: Vertical
EUT: 300Mbps Wireless N Nano Router	Power: AC 120V/60Hz
Note: Mode 1:Transmit at 2422MHz by 802.11B	

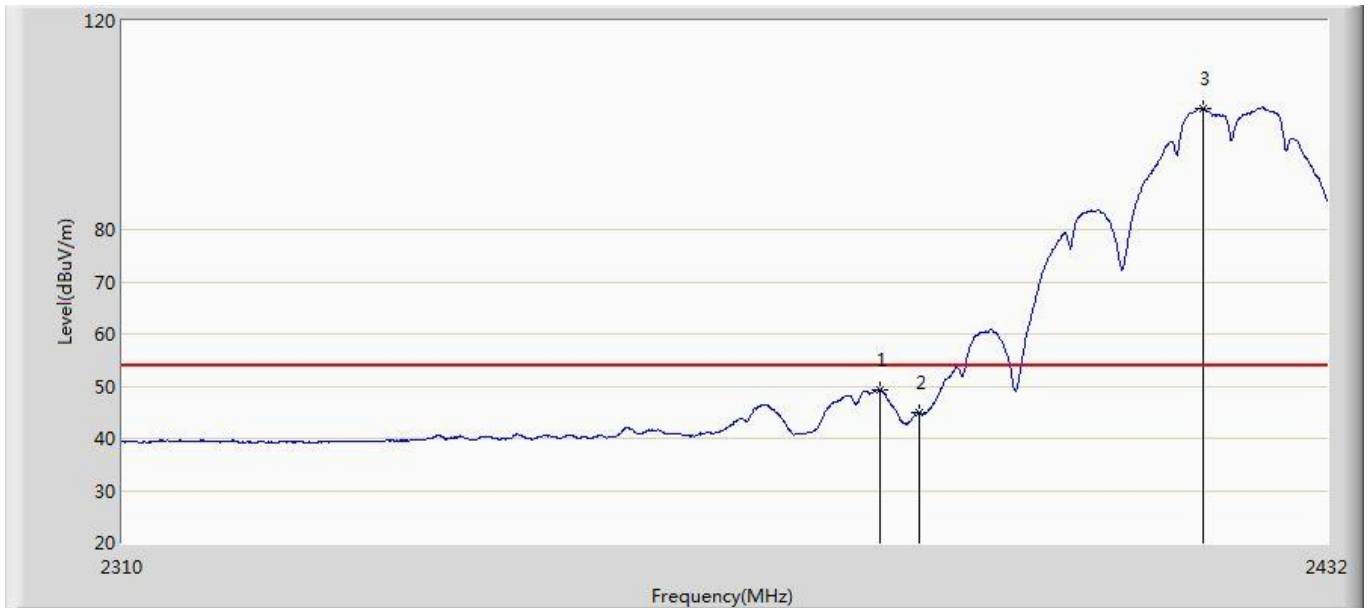

No	Mark	Frequency (MHz)	Measure Level (dBuV/m)	Reading Level (dBuV)	Over Limit (dB)	Limit (dBuV/m)	Factor (dB)	Type
1		2385.945	49.366	13.037	-4.634	54.000	36.329	AV
2		2390.000	44.975	8.645	-9.025	54.000	36.329	AV
3	*	2419.190	103.096	66.639	49.096	54.000	36.457	AV

Site: AC5	Time: 2017/07/07 - 11:07
Limit: FCC_Part15.209_RE(3m)	Margin: 0
Probe: Horn_3117_00167055(1-18GHz)	Polarity: Vertical
EUT: 300Mbps Wireless N Nano Router	Power: AC 120V/60Hz
Note: Mode 1:Transmit at 2422MHz by 802.11B	

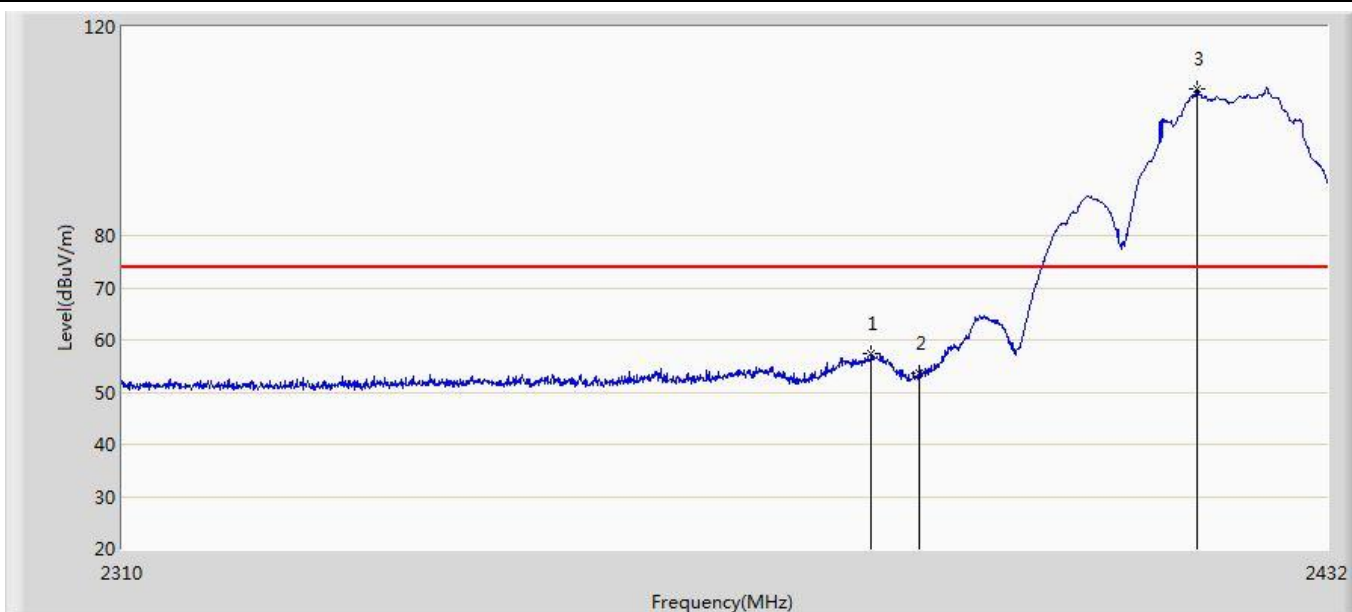

No	Mark	Frequency (MHz)	Measure Level (dBuV/m)	Reading Level (dBuV)	Over Limit (dB)	Limit (dBuV/m)	Factor (dB)	Type
1		2385.152	57.286	20.957	-16.714	74.000	36.329	PK
2		2390.000	53.573	17.243	-20.427	74.000	36.329	PK
3	*	2418.519	108.071	71.625	34.071	74.000	36.446	PK

Site: AC5	Time: 2017/07/07 - 11:11
Limit: FCC_Part15.209_RE(3m)	Margin: 0
Probe: Horn_3117_00167055(1-18GHz)	Polarity: Horizontal
EUT: 300Mbps Wireless N Nano Router	Power: AC 120V/60Hz
Note: Mode 1:Transmit at 2452MHz by 802.11B	

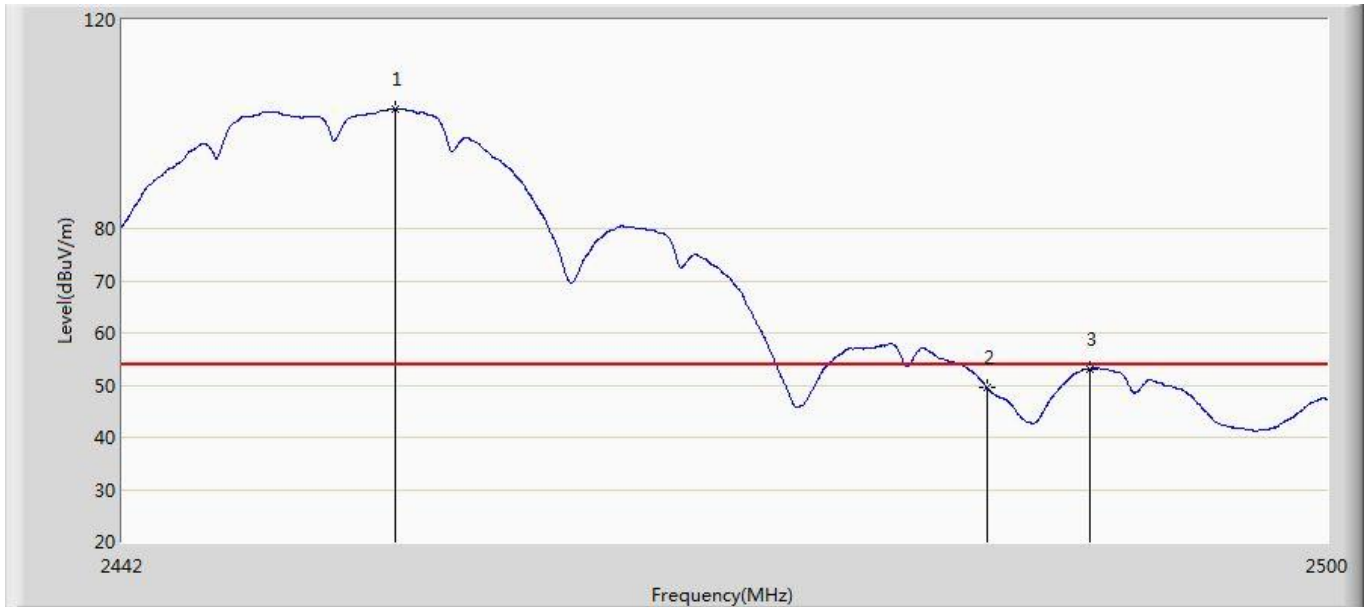

No	Mark	Frequency (MHz)	Measure Level (dBuV/m)	Reading Level (dBuV)	Over Limit (dB)	Limit (dBuV/m)	Factor (dB)	Type
1	*	2455.021	102.865	66.374	48.865	54.000	36.491	AV
2		2483.500	49.527	13.060	-4.473	54.000	36.467	AV
3		2488.516	53.126	16.584	-0.874	54.000	36.541	AV

Site: AC5	Time: 2017/07/07 - 11:17
Limit: FCC_Part15.209_RE(3m)	Margin: 0
Probe: Horn_3117_00167055(1-18GHz)	Polarity: Horizontal
EUT: 300Mbps Wireless N Nano Router	Power: AC 120V/60Hz
Note: Mode 1:Transmit at 2452MHz by 802.11B	

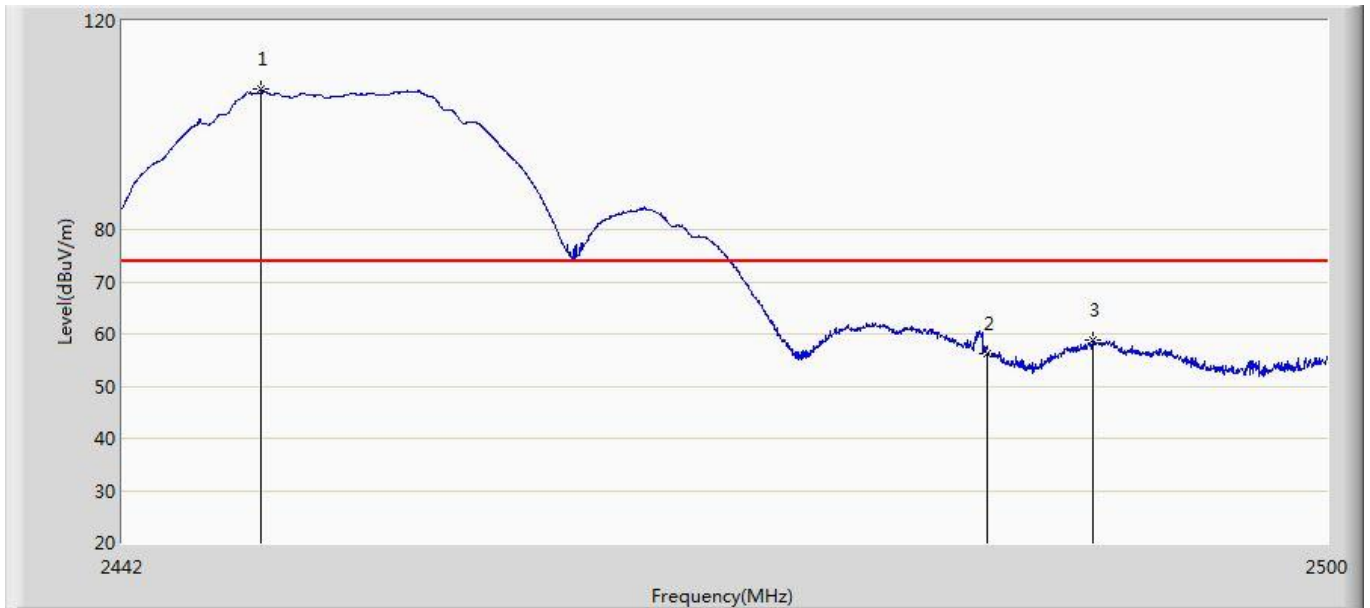

No	Mark	Frequency (MHz)	Measure Level (dBuV/m)	Reading Level (dBuV)	Over Limit (dB)	Limit (dBuV/m)	Factor (dB)	Type
1	*	2448.641	106.941	70.576	32.941	74.000	36.365	PK
2		2483.500	56.106	19.639	-17.894	74.000	36.467	PK
3		2488.661	58.714	22.171	-15.286	74.000	36.543	PK

Site: AC5	Time: 2017/07/07 - 11:17
Limit: FCC_Part15.209_RE(3m)	Margin: 0
Probe: Horn_3117_00167055(1-18GHz)	Polarity: Vertical
EUT: 300Mbps Wireless N Nano Router	Power: AC 120V/60Hz
Note: Mode 1:Transmit at 2452MHz by 802.11B	

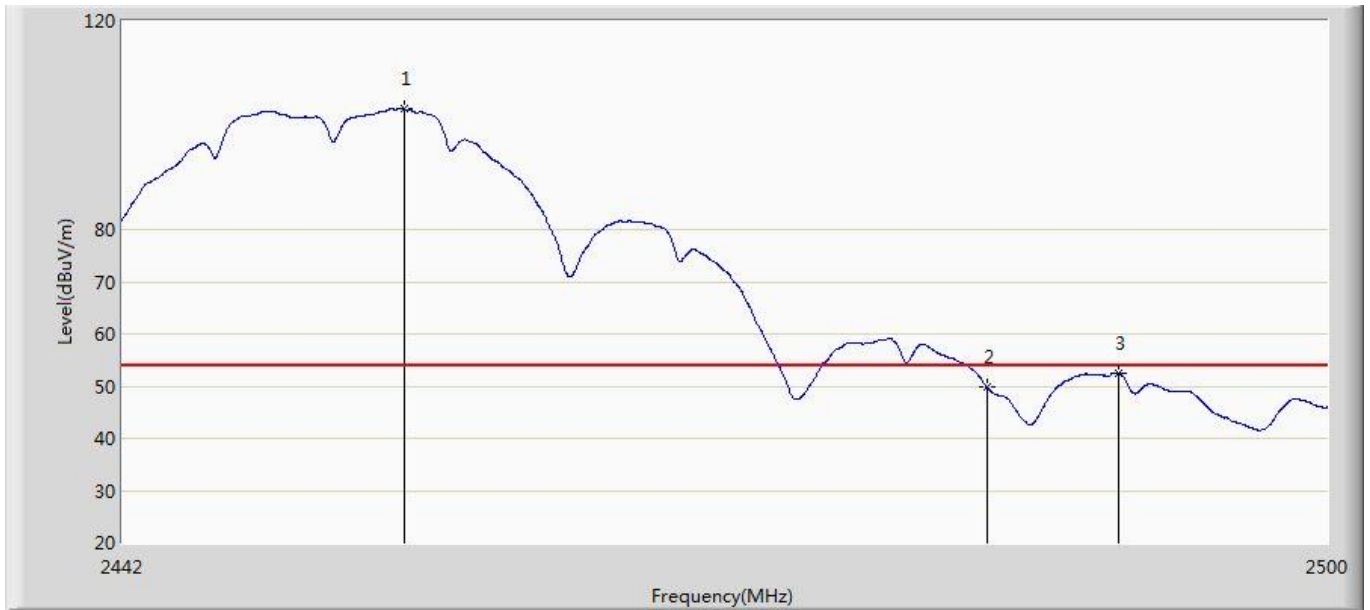

No	Mark	Frequency (MHz)	Measure Level (dBuV/m)	Reading Level (dBuV)	Over Limit (dB)	Limit (dBuV/m)	Factor (dB)	Type
1	*	2455.456	103.110	66.610	49.110	54.000	36.499	AV
2		2483.500	49.742	13.275	-4.258	54.000	36.467	AV
3		2489.879	52.526	15.964	-1.474	54.000	36.562	AV

Site: AC5	Time: 2017/07/07 - 11:20
Limit: FCC_Part15.209_RE(3m)	Margin: 0
Probe: Horn_3117_00167055(1-18GHz)	Polarity: Vertical
EUT: 300Mbps Wireless N Nano Router	Power: AC 120V/60Hz
Note: Mode 1:Transmit at 2452MHz by 802.11B	

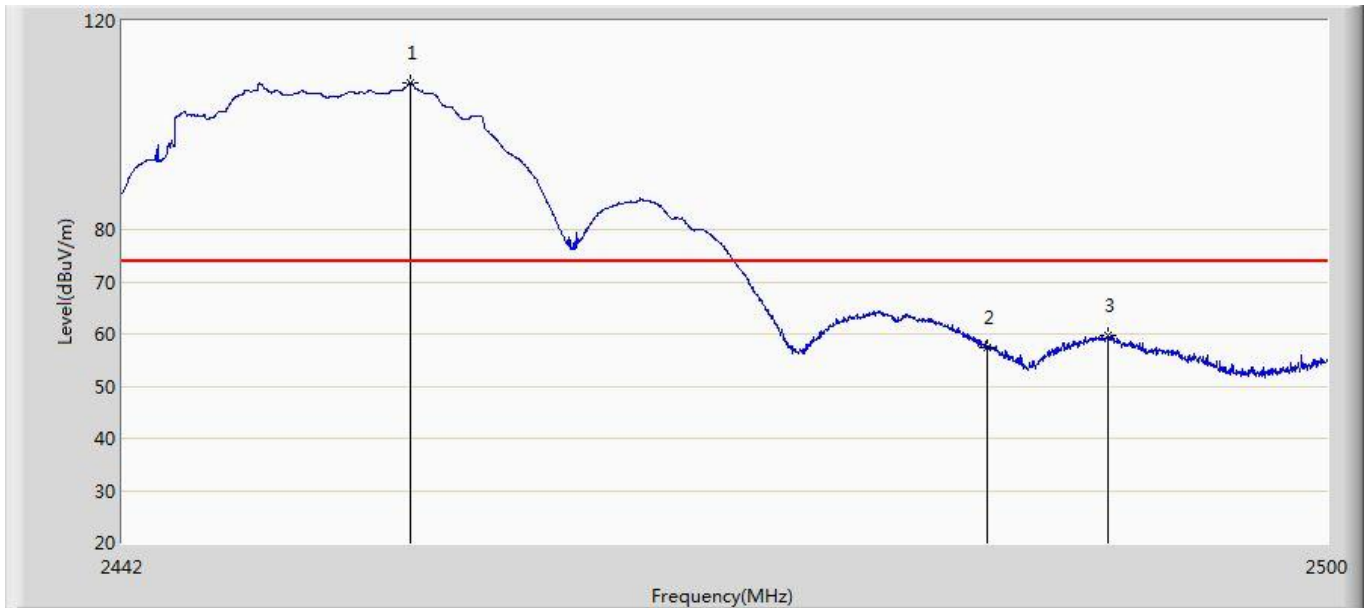

No	Mark	Frequency (MHz)	Measure Level (dBuV/m)	Reading Level (dBuV)	Over Limit (dB)	Limit (dBuV/m)	Factor (dB)	Type
1	*	2455.746	108.166	71.661	34.166	74.000	36.506	PK
2		2483.500	57.534	21.067	-16.466	74.000	36.467	PK
3		2489.386	59.599	23.044	-14.401	74.000	36.554	PK

Site: AC5	Time: 2017/05/18- 10:28
Limit: FCC_Part15.209_RE(3m)	Margin: 0
Probe: Horn_3117_00167055(1-18GHz)	Polarity: Horizontal
EUT:300Mbps Wireless N Nano Router	Power: AC 120V/60Hz
Note: Mode 1:Transmit at 2462MHz by 802.11B	

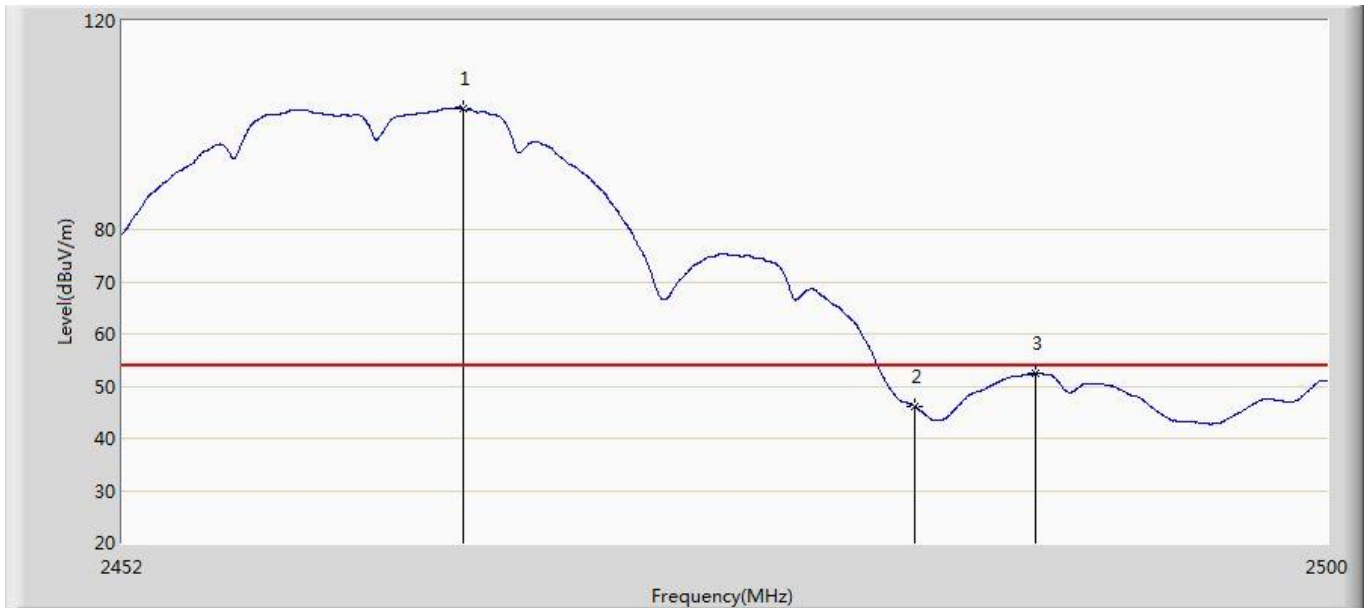

No	Mark	Frequency (MHz)	Measure Level (dBuV/m)	Reading Level (dBuV)	Over Limit (dB)	Limit (dBuV/m)	Factor (dB)	Type
1	*	2465.488	103.133	66.551	49.133	54.000	36.582	AV
2		2483.500	46.039	9.572	-7.961	54.000	36.467	AV
3		2488.312	52.458	15.919	-1.542	54.000	36.539	AV



Site: AC5	Time: 2017/05/18- 10:34
Limit: FCC_Part15.209_RE(3m)	Margin: 0
Probe: Horn_3117_00167055(1-18GHz)	Polarity: Horizontal
EUT:300Mbps Wireless N Nano Router	Power: AC 120V/60Hz
Note: Mode 1:Transmit at 2462MHz by 802.11B	

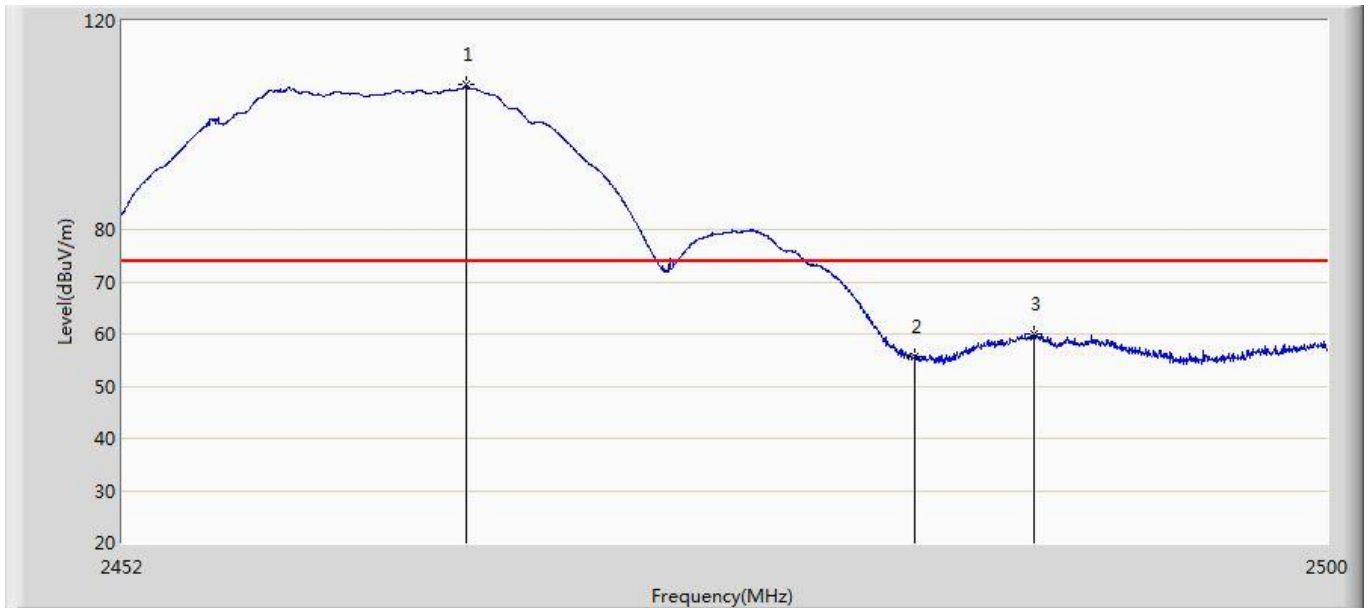

No	Mark	Frequency (MHz)	Measure Level (dBuV/m)	Reading Level (dBuV)	Over Limit (dB)	Limit (dBuV/m)	Factor (dB)	Type
1	*	2465.632	107.830	71.250	33.830	74.000	36.580	PK
2		2483.500	55.778	19.311	-18.222	74.000	36.467	PK
3		2488.216	59.951	23.414	-14.049	74.000	36.537	PK

Site: AC5	Time: 2017/05/18- 10:41
Limit: FCC_Part15.209_RE(3m)	Margin: 0
Probe: Horn_3117_00167055(1-18GHz)	Polarity: Vertical
EUT:300Mbps Wireless N Nano Router	Power: AC 120V/60Hz
Note: Mode 1:Transmit at 2462MHz by 802.11B	

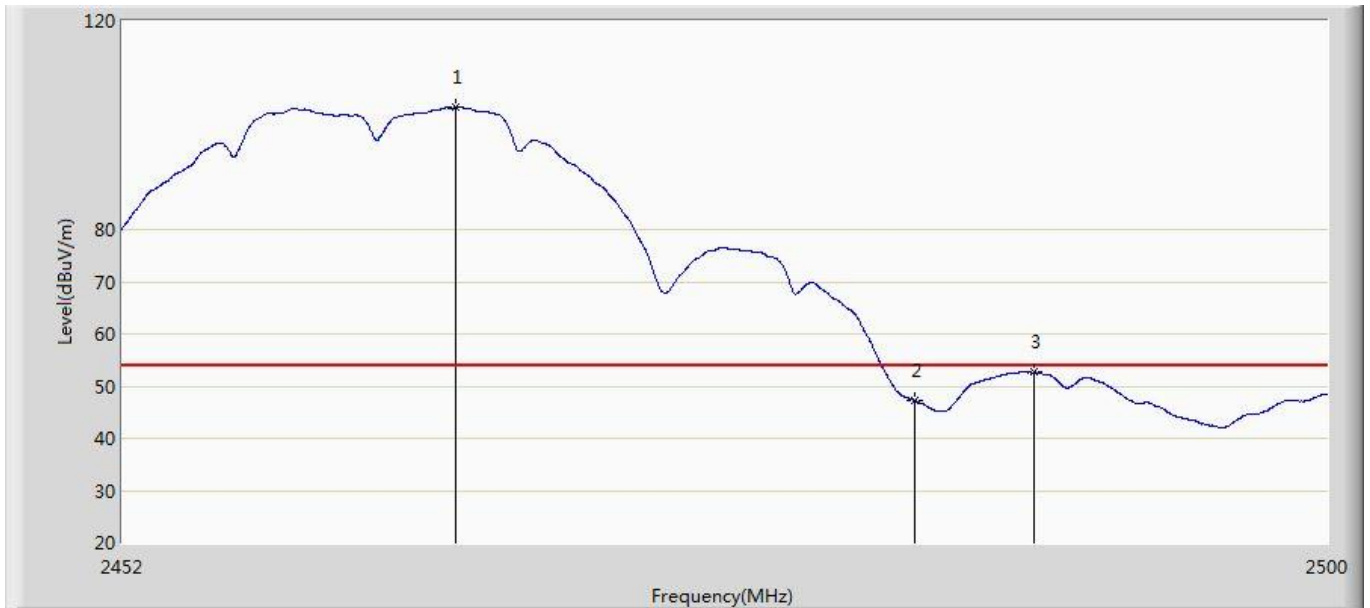

No	Mark	Frequency (MHz)	Measure Level (dBuV/m)	Reading Level (dBuV)	Over Limit (dB)	Limit (dBuV/m)	Factor (dB)	Type
1	*	2465.176	103.399	66.813	49.399	54.000	36.586	AV
2		2483.500	47.177	10.710	-6.823	54.000	36.467	AV
3		2488.240	52.628	16.090	-1.372	54.000	36.538	AV

Site: AC5	Time: 2017/05/18- 10:43
Limit: FCC_Part15.209_RE(3m)	Margin: 0
Probe: Horn_3117_00167055(1-18GHz)	Polarity: Vertical
EUT:300Mbps Wireless N Nano Router	Power: AC 120V/60Hz
Note: Mode 1:Transmit at 2462MHz by 802.11B	

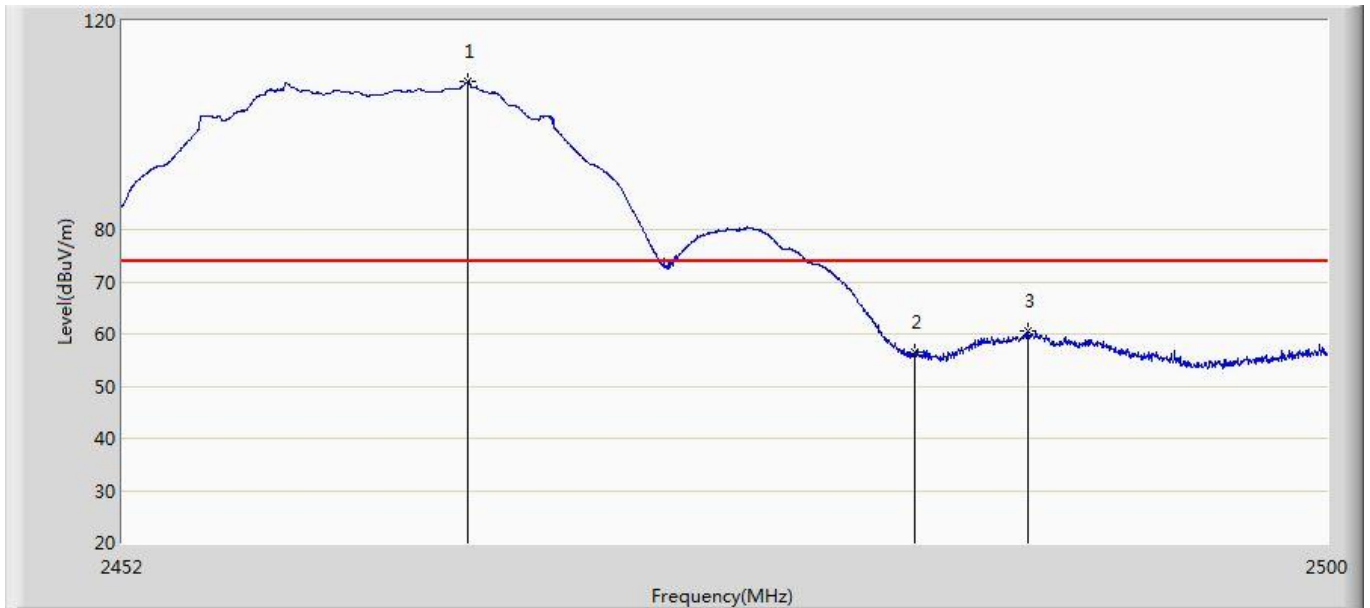

No	Mark	Frequency (MHz)	Measure Level (dBuV/m)	Reading Level (dBuV)	Over Limit (dB)	Limit (dBuV/m)	Factor (dB)	Type
1	*	2465.704	108.381	71.802	34.381	74.000	36.580	PK
2		2483.500	56.400	19.933	-17.600	74.000	36.467	PK
3		2488.024	60.535	24.001	-13.465	74.000	36.535	PK

Site: AC5	Time: 2017/05/18- 10:46
Limit: FCC_Part15.209_RE(3m)	Margin: 0
Probe: Horn_3117_00167055(1-18GHz)	Polarity: Horizontal
EUT:300Mbps Wireless N Nano Router	Power: AC 120V/60Hz
Note: Mode 2:Transmit at 2412MHz by 802.11G	

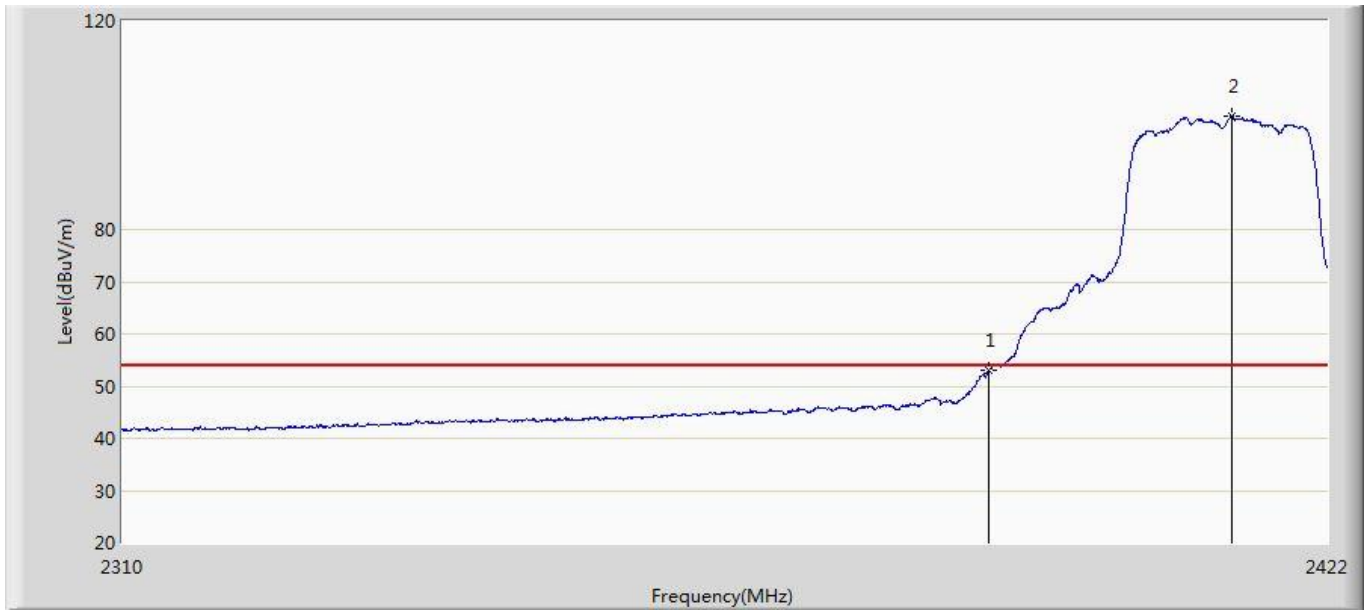

No	Mark	Frequency (MHz)	Measure Level (dBuV/m)	Reading Level (dBuV)	Over Limit (dB)	Limit (dBuV/m)	Factor (dB)	Type
1		2390.000	53.077	16.747	-0.923	54.000	36.329	AV
2	*	2412.984	101.790	65.431	47.790	54.000	36.358	AV

Site: AC5	Time: 2017/05/18- 10:54
Limit: FCC_Part15.209_RE(3m)	Margin: 0
Probe: Horn_3117_00167055(1-18GHz)	Polarity: Horizontal
EUT:300Mbps Wireless N Nano Router	Power: AC 120V/60Hz
Note: Mode 2:Transmit at 2412MHz by 802.11G	

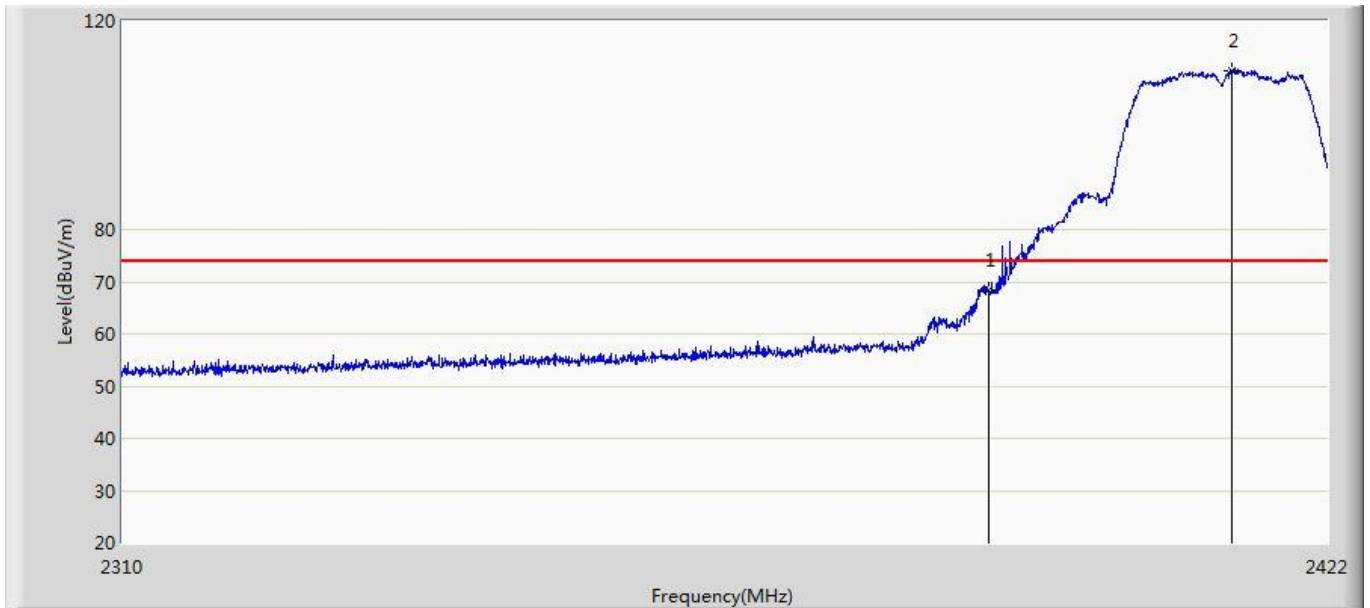

No	Mark	Frequency (MHz)	Measure Level (dBuV/m)	Reading Level (dBuV)	Over Limit (dB)	Limit (dBuV/m)	Factor (dB)	Type
1		2390.000	68.278	31.948	-5.722	74.000	36.329	PK
2	*	2412.984	110.564	74.205	36.564	74.000	36.358	PK

Site: AC5	Time: 2017/05/18- 10:56
Limit: FCC_Part15.209_RE(3m)	Margin: 0
Probe: Horn_3117_00167055(1-18GHz)	Polarity: Vertical
EUT:300Mbps Wireless N Nano Router	Power: AC 120V/60Hz
Note: Mode 2:Transmit at 2412MHz by 802.11G	

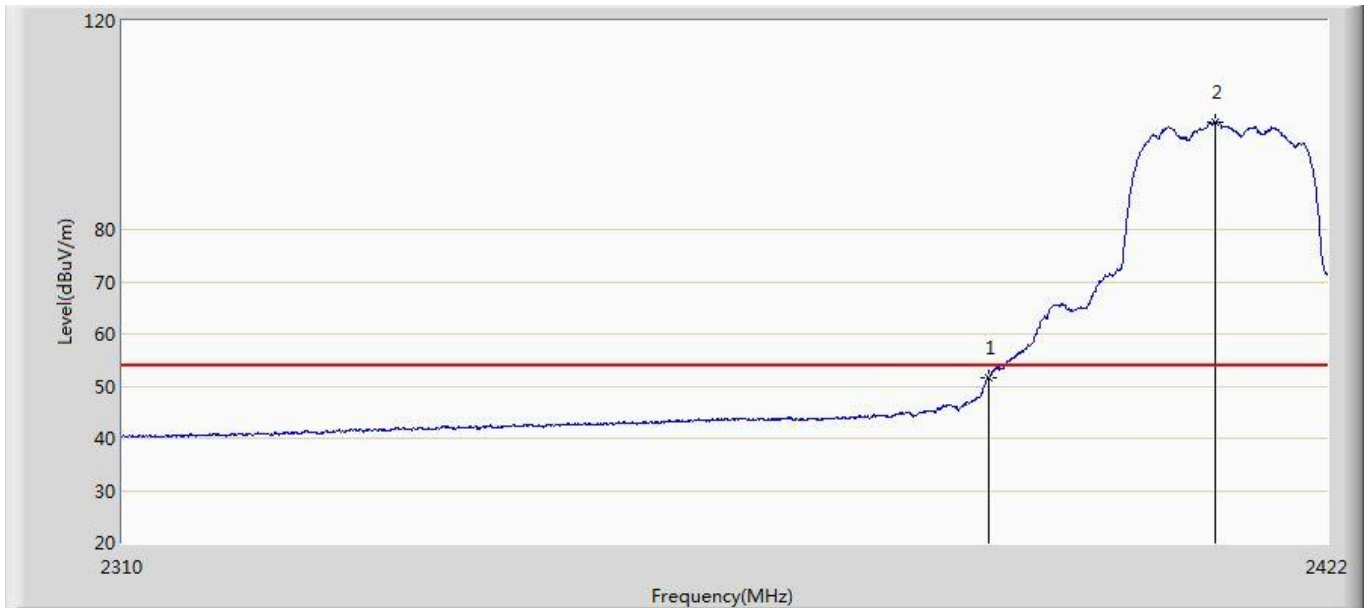

No	Mark	Frequency (MHz)	Measure Level (dBuV/m)	Reading Level (dBuV)	Over Limit (dB)	Limit (dBuV/m)	Factor (dB)	Type
1		2390.000	51.665	15.335	-2.335	54.000	36.329	AV
2	*	2411.360	100.596	64.263	46.596	54.000	36.332	AV

Site: AC5	Time: 2017/05/18- 10:58
Limit: FCC_Part15.209_RE(3m)	Margin: 0
Probe: Horn_3117_00167055(1-18GHz)	Polarity: Vertical
EUT:300Mbps Wireless N Nano Router	Power: AC 120V/60Hz
Note: Mode 2:Transmit at 2412MHz by 802.11G	

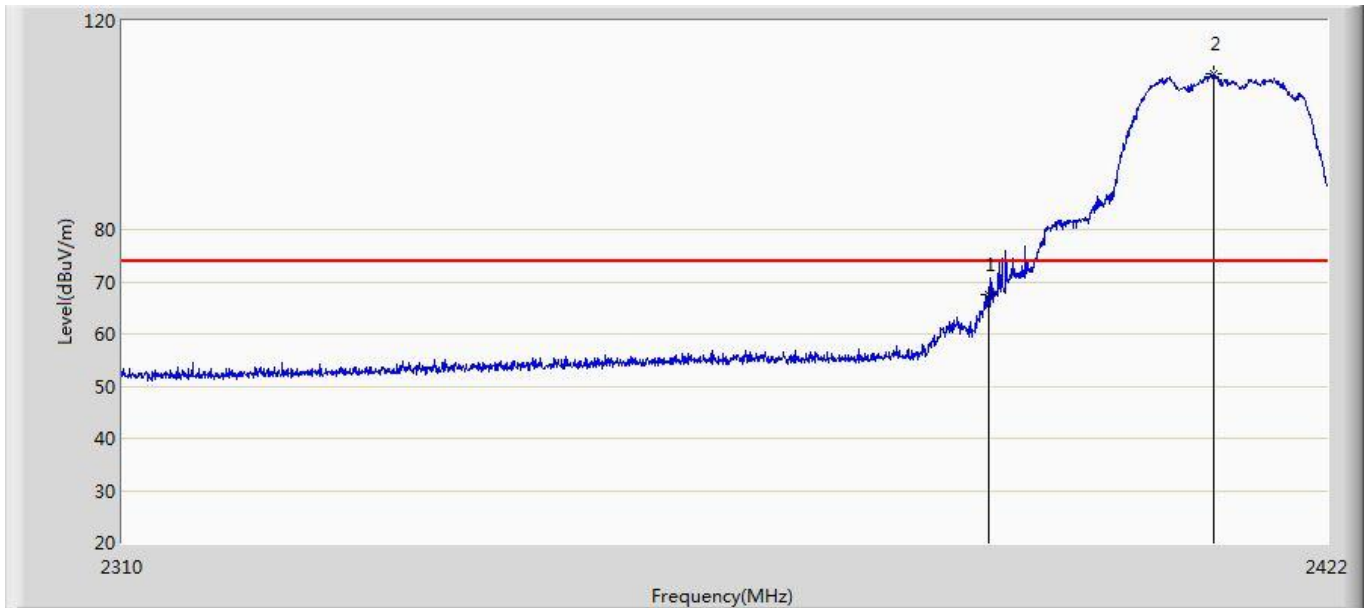

No	Mark	Frequency (MHz)	Measure Level (dBuV/m)	Reading Level (dBuV)	Over Limit (dB)	Limit (dBuV/m)	Factor (dB)	Type
1		2390.000	67.665	31.335	-6.335	74.000	36.329	PK
2	*	2411.248	109.752	73.421	35.752	74.000	36.331	PK

Site: AC5	Time: 2017/07/07 - 11:26
Limit: FCC_Part15.209_RE(3m)	Margin: 0
Probe: Horn_3117_00167055(1-18GHz)	Polarity: Horizontal
EUT: 300Mbps Wireless N Nano Router	Power: AC 120V/60Hz
Note: Mode 2:Transmit at 2422MHz by 802.11G	

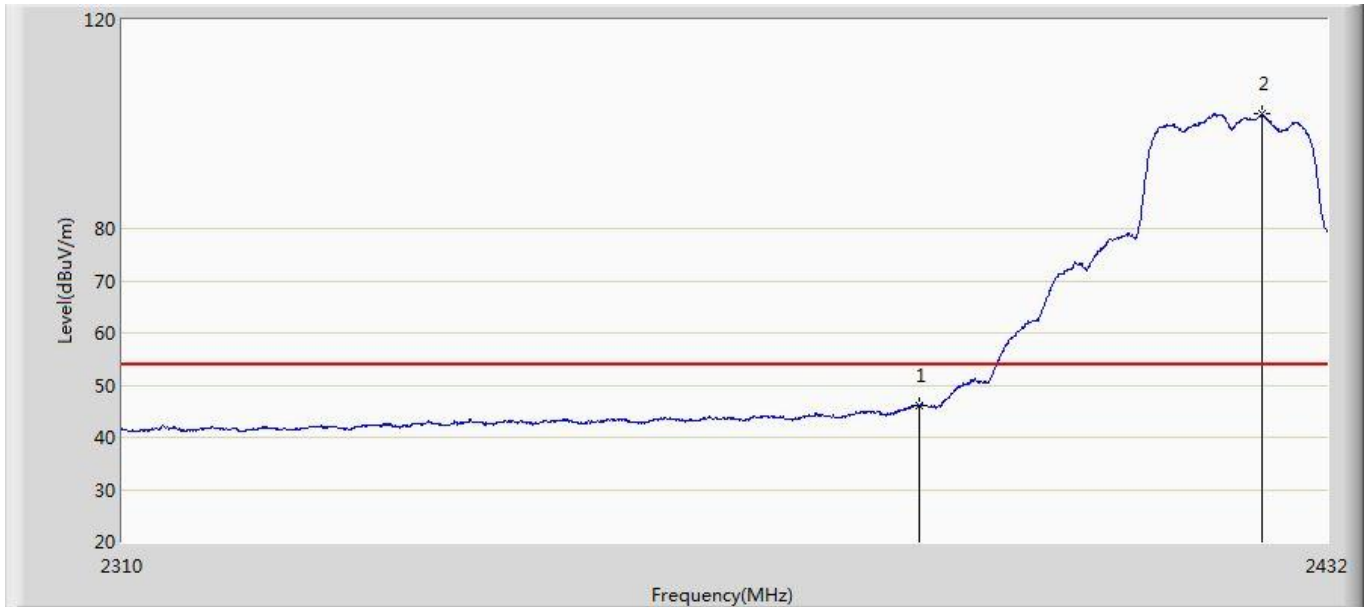

No	Mark	Frequency (MHz)	Measure Level (dBuV/m)	Reading Level (dBuV)	Over Limit (dB)	Limit (dBuV/m)	Factor (dB)	Type
1		2390.000	46.077	9.747	-7.923	54.000	36.329	AV
2	*	2425.290	101.939	65.385	47.939	54.000	36.554	AV



Site: AC5	Time: 2017/07/07 - 11:30
Limit: FCC_Part15.209_RE(3m)	Margin: 0
Probe: Horn_3117_00167055(1-18GHz)	Polarity: Horizontal
EUT: 300Mbps Wireless N Nano Router	Power: AC 120V/60Hz
Note: Mode 2:Transmit at 2422MHz by 802.11G	

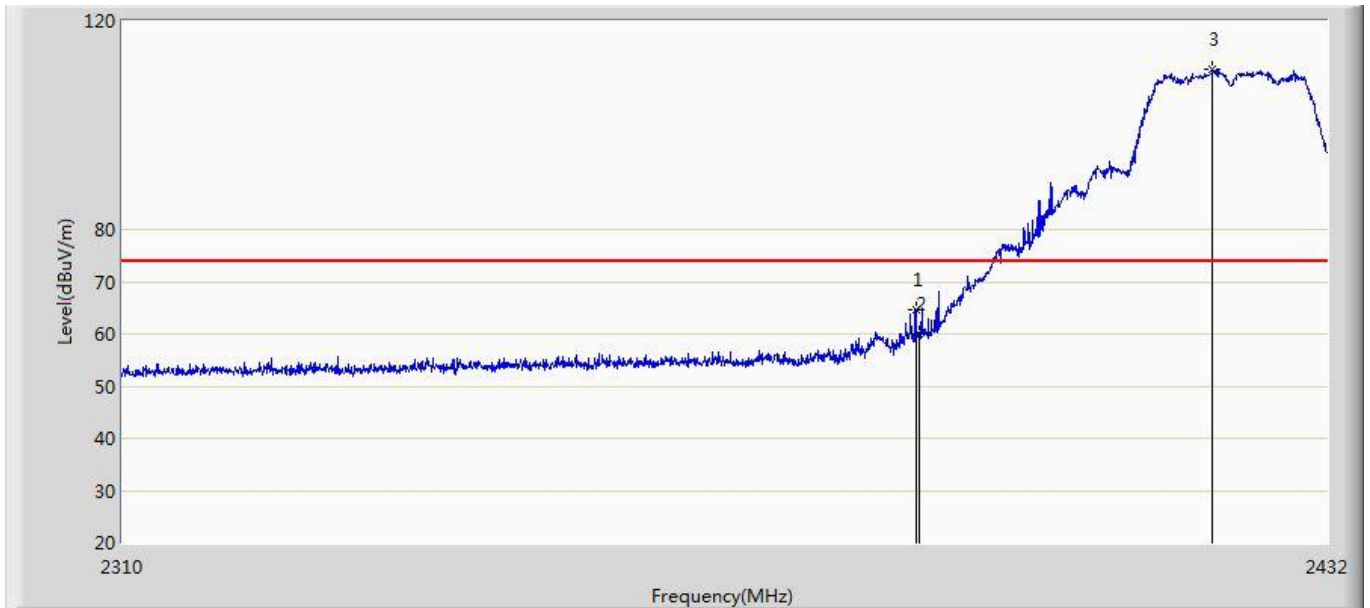

No	Mark	Frequency (MHz)	Measure Level (dBuV/m)	Reading Level (dBuV)	Over Limit (dB)	Limit (dBuV/m)	Factor (dB)	Type
1		2389.666	64.709	28.380	-9.291	74.000	36.330	PK
2		2390.000	59.885	23.555	-14.115	74.000	36.329	PK
3	*	2420.105	110.829	74.357	36.829	74.000	36.471	PK

Site: AC5	Time: 2017/07/07 - 11:33
Limit: FCC_Part15.209_RE(3m)	Margin: 0
Probe: Horn_3117_00167055(1-18GHz)	Polarity: Vertical
EUT: 300Mbps Wireless N Nano Router	Power: AC 120V/60Hz
Note: Mode 2:Transmit at 2422MHz by 802.11G	

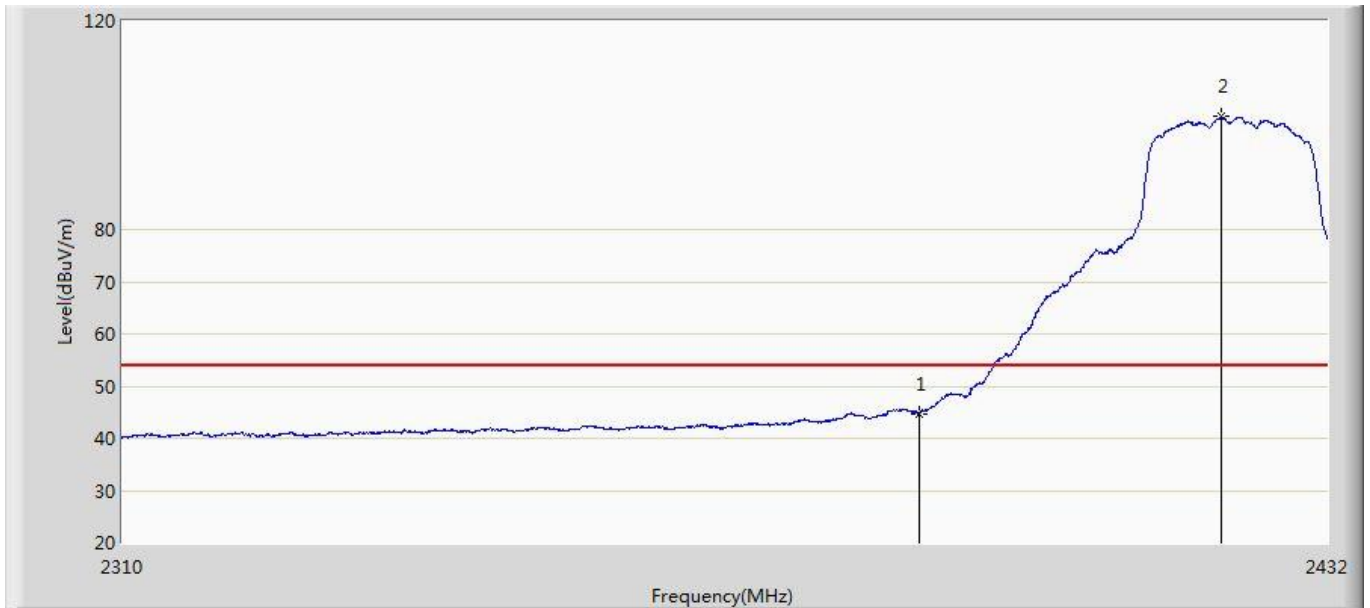

No	Mark	Frequency (MHz)	Measure Level (dBuV/m)	Reading Level (dBuV)	Over Limit (dB)	Limit (dBuV/m)	Factor (dB)	Type
1		2390.000	44.741	8.411	-9.259	54.000	36.329	AV
2	*	2421.081	101.629	65.142	47.629	54.000	36.487	AV

Site: AC5	Time: 2017/07/07 - 11:35
Limit: FCC_Part15.209_RE(3m)	Margin: 0
Probe: Horn_3117_00167055(1-18GHz)	Polarity: Vertical
EUT: 300Mbps Wireless N Nano Router	Power: AC 120V/60Hz
Note: Mode 2:Transmit at 2422MHz by 802.11G	

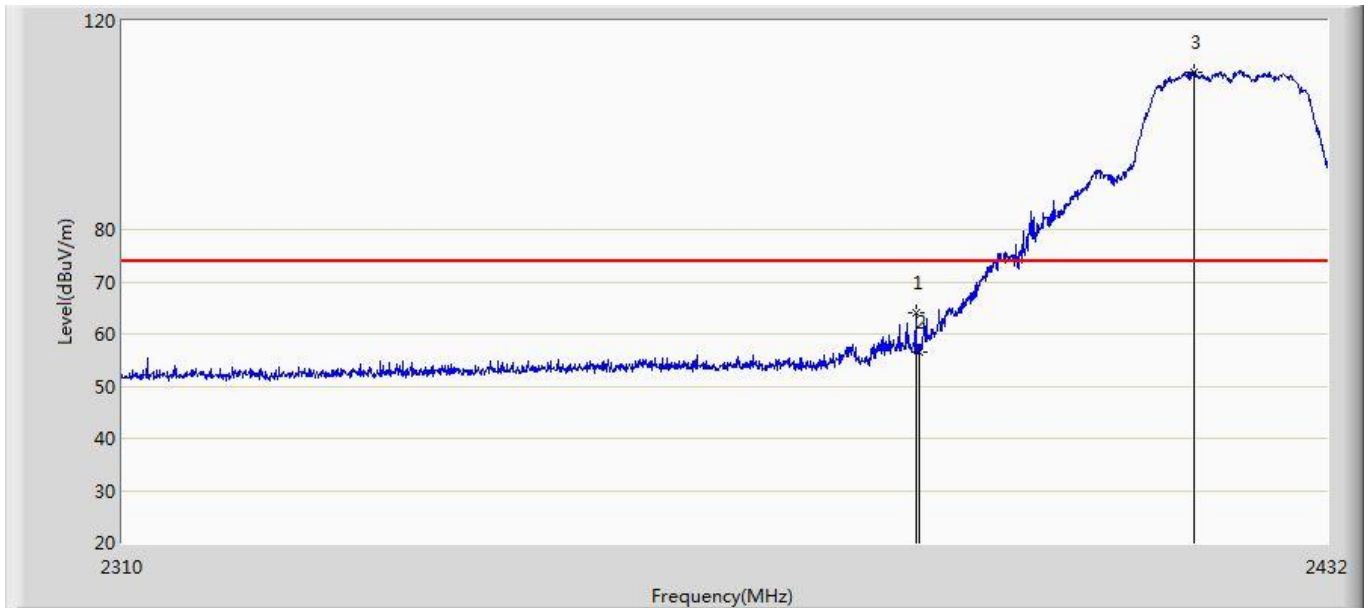

No	Mark	Frequency (MHz)	Measure Level (dBuV/m)	Reading Level (dBuV)	Over Limit (dB)	Limit (dBuV/m)	Factor (dB)	Type
1		2389.666	63.936	27.607	-10.064	74.000	36.330	PK
2		2390.000	56.580	20.250	-17.420	74.000	36.329	PK
3	*	2418.275	110.283	73.840	36.283	74.000	36.443	PK

Site: AC5	Time: 2017/07/07 - 11:39
Limit: FCC_Part15.209_RE(3m)	Margin: 0
Probe: Horn_3117_00167055(1-18GHz)	Polarity: Horizontal
EUT: 300Mbps Wireless N Nano Router	Power: AC 120V/60Hz
Note: Mode 2:Transmit at 2452MHz by 802.11G	

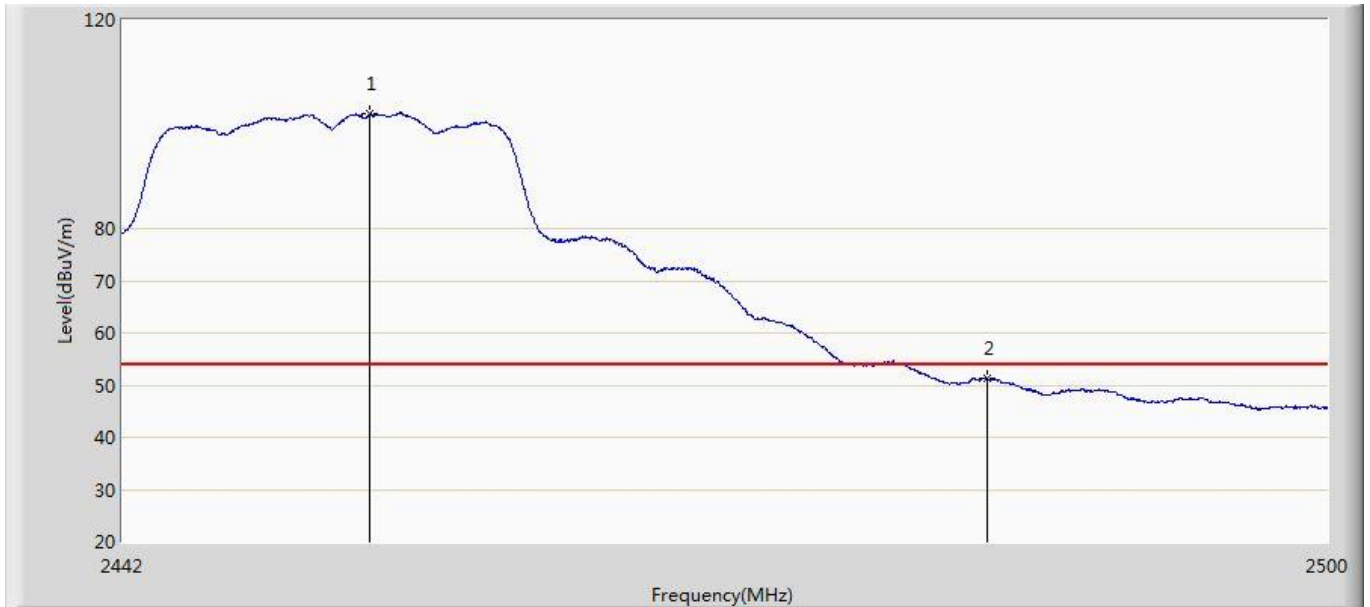

No	Mark	Frequency (MHz)	Measure Level (dBuV/m)	Reading Level (dBuV)	Over Limit (dB)	Limit (dBuV/m)	Factor (dB)	Type
1	*	2453.832	101.917	65.449	47.917	54.000	36.467	AV
2		2483.500	51.304	14.837	-2.696	54.000	36.467	AV

Site: AC5	Time: 2017/07/07 - 11:42
Limit: FCC_Part15.209_RE(3m)	Margin: 0
Probe: Horn_3117_00167055(1-18GHz)	Polarity: Horizontal
EUT: 300Mbps Wireless N Nano Router	Power: AC 120V/60Hz
Note: Mode 2:Transmit at 2452MHz by 802.11G	



No	Mark	Frequency (MHz)	Measure Level (dBuV/m)	Reading Level (dBuV)	Over Limit (dB)	Limit (dBuV/m)	Factor (dB)	Type
1	*	2455.862	110.770	74.262	36.770	74.000	36.508	PK
2		2483.500	65.603	29.136	-8.397	74.000	36.467	PK

Site: AC5	Time: 2017/07/07 - 11:44
Limit: FCC_Part15.209_RE(3m)	Margin: 0
Probe: Horn_3117_00167055(1-18GHz)	Polarity: Vertical
EUT: 300Mbps Wireless N Nano Router	Power: AC 120V/60Hz
Note: Mode 2:Transmit at 2452MHz by 802.11G	

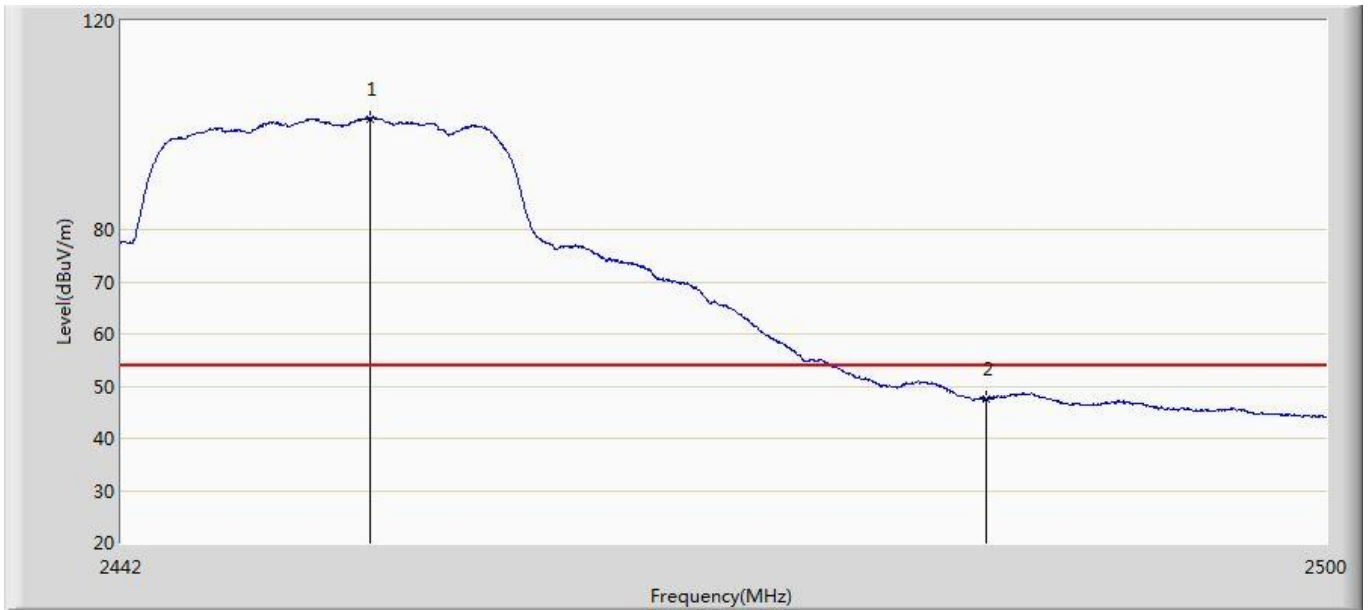

No	Mark	Frequency (MHz)	Measure Level (dBuV/m)	Reading Level (dBuV)	Over Limit (dB)	Limit (dBuV/m)	Factor (dB)	Type
1	*	2453.861	101.271	64.803	47.271	54.000	36.468	AV
2		2483.500	47.511	11.044	-6.489	54.000	36.467	AV

Site: AC5	Time: 2017/07/07 - 11:46
Limit: FCC_Part15.209_RE(3m)	Margin: 0
Probe: Horn_3117_00167055(1-18GHz)	Polarity: Vertical
EUT: 300Mbps Wireless N Nano Router	Power: AC 120V/60Hz
Note: Mode 2:Transmit at 2452MHz by 802.11G	

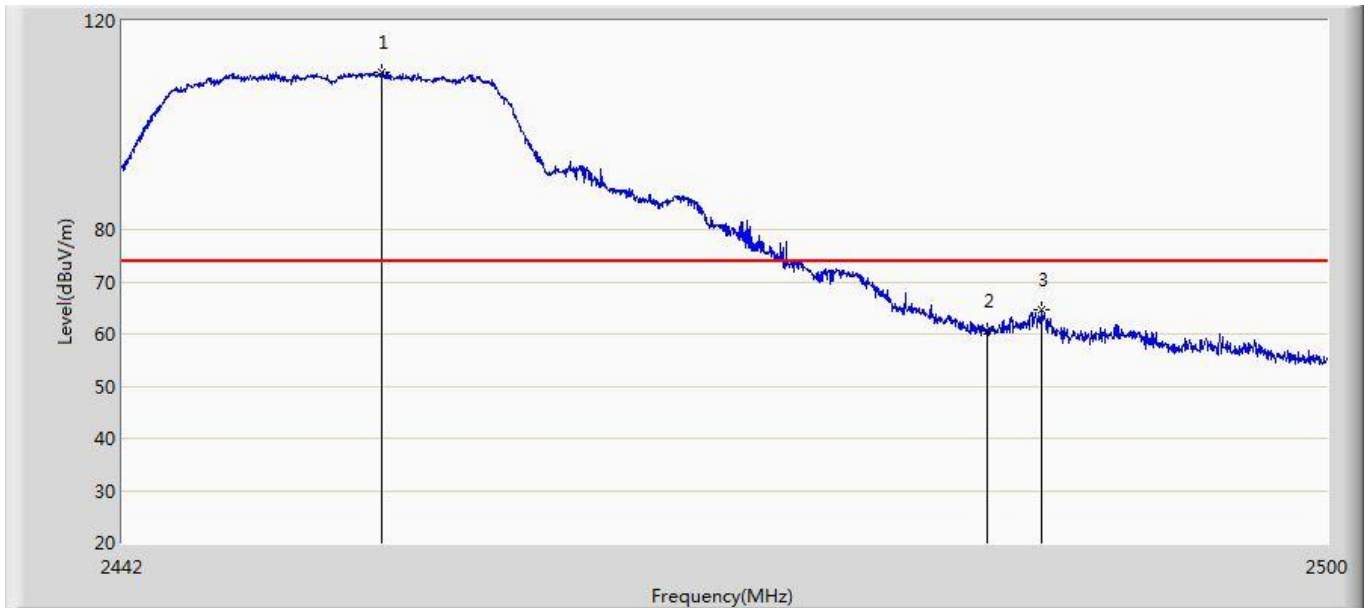

No	Mark	Frequency (MHz)	Measure Level (dBuV/m)	Reading Level (dBuV)	Over Limit (dB)	Limit (dBuV/m)	Factor (dB)	Type
1	*	2454.354	110.013	73.535	36.013	74.000	36.478	PK
2		2483.500	60.647	24.180	-13.353	74.000	36.467	PK
3		2486.167	64.635	28.128	-9.365	74.000	36.506	PK

Site: AC5	Time: 2017/05/18- 11:12
Limit: FCC_Part15.209_RE(3m)	Margin: 0
Probe: Horn_3117_00167055(1-18GHz)	Polarity: Horizontal
EUT:300Mbps Wireless N Nano Router	Power: AC 120V/60Hz
Note: Mode 2:Transmit at 2462MHz by 802.11G	

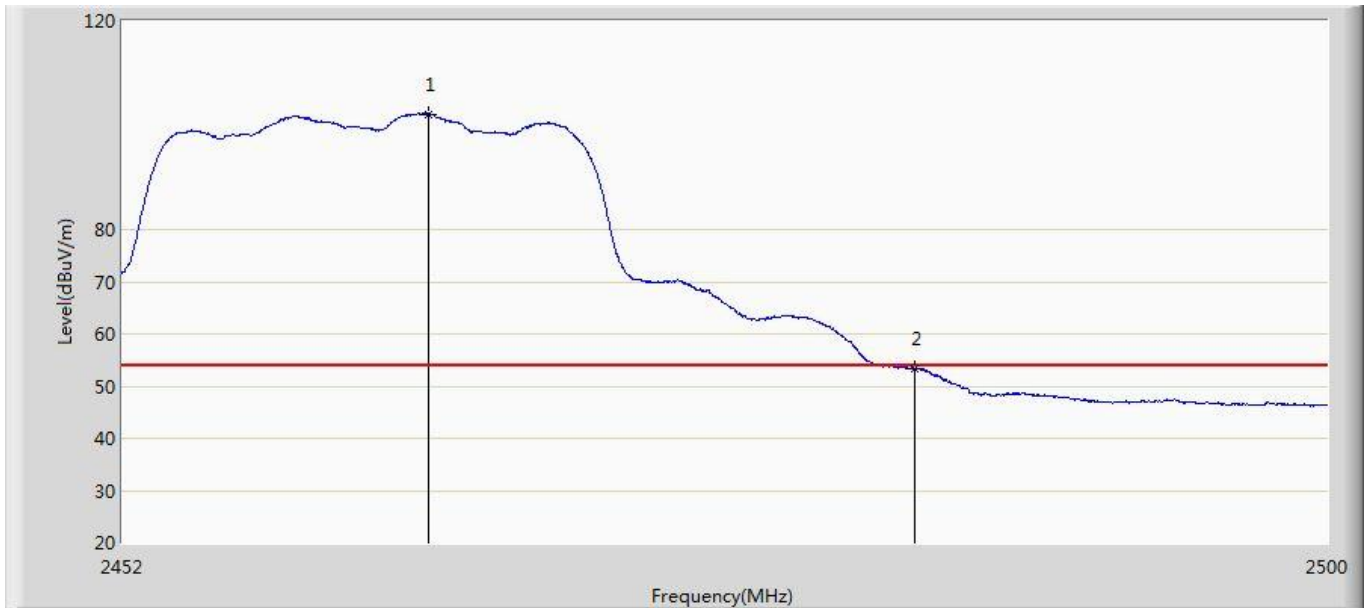

No	Mark	Frequency (MHz)	Measure Level (dBuV/m)	Reading Level (dBuV)	Over Limit (dB)	Limit (dBuV/m)	Factor (dB)	Type
1	*	2464.096	102.166	65.565	48.166	54.000	36.601	AV
2		2483.500	53.319	16.852	-0.681	54.000	36.467	AV



Site: AC5	Time: 2017/05/18- 11:17
Limit: FCC_Part15.209_RE(3m)	Margin: 0
Probe: Horn_3117_00167055(1-18GHz)	Polarity: Horizontal
EUT:300Mbps Wireless N Nano Router	Power: AC 120V/60Hz
Note: Mode 2:Transmit at 2462MHz by 802.11G	

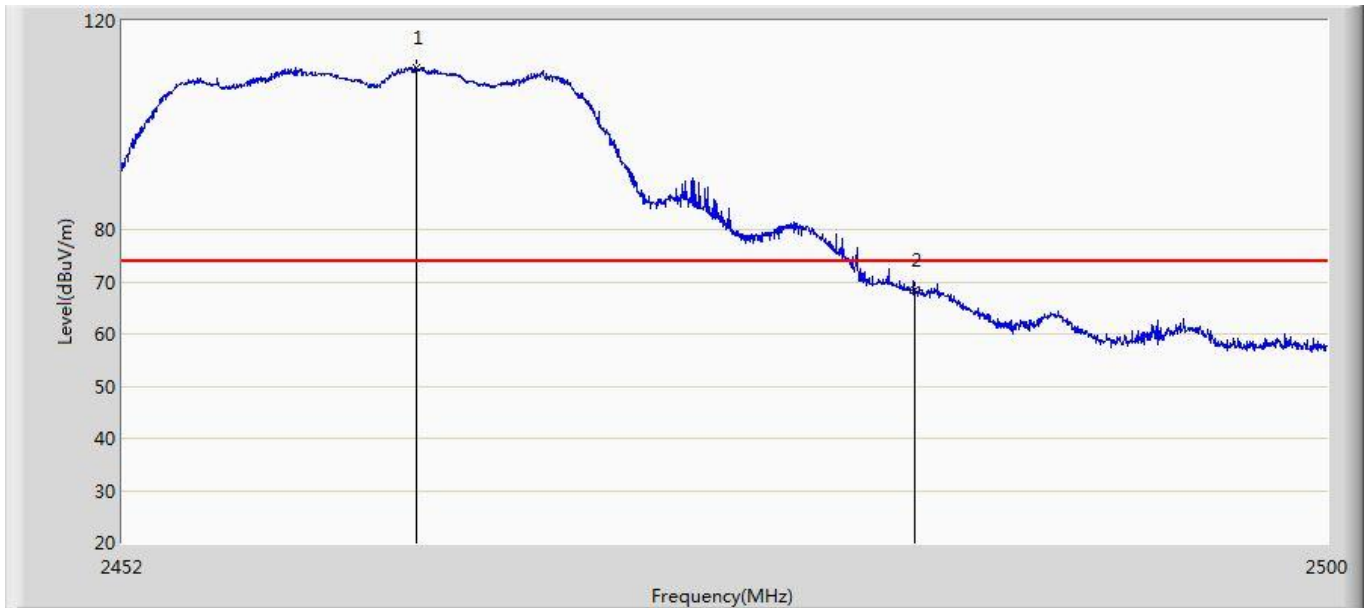

No	Mark	Frequency (MHz)	Measure Level (dBuV/m)	Reading Level (dBuV)	Over Limit (dB)	Limit (dBuV/m)	Factor (dB)	Type
1	*	2463.640	110.922	74.315	36.922	74.000	36.607	PK
2		2483.500	68.348	31.881	-5.652	74.000	36.467	PK

Site: AC5	Time: 2017/05/18- 11:19
Limit: FCC_Part15.209_RE(3m)	Margin: 0
Probe: Horn_3117_00167055(1-18GHz)	Polarity: Vertical
EUT:300Mbps Wireless N Nano Router	Power: AC 120V/60Hz
Note: Mode 2:Transmit at 2462MHz by 802.11G	

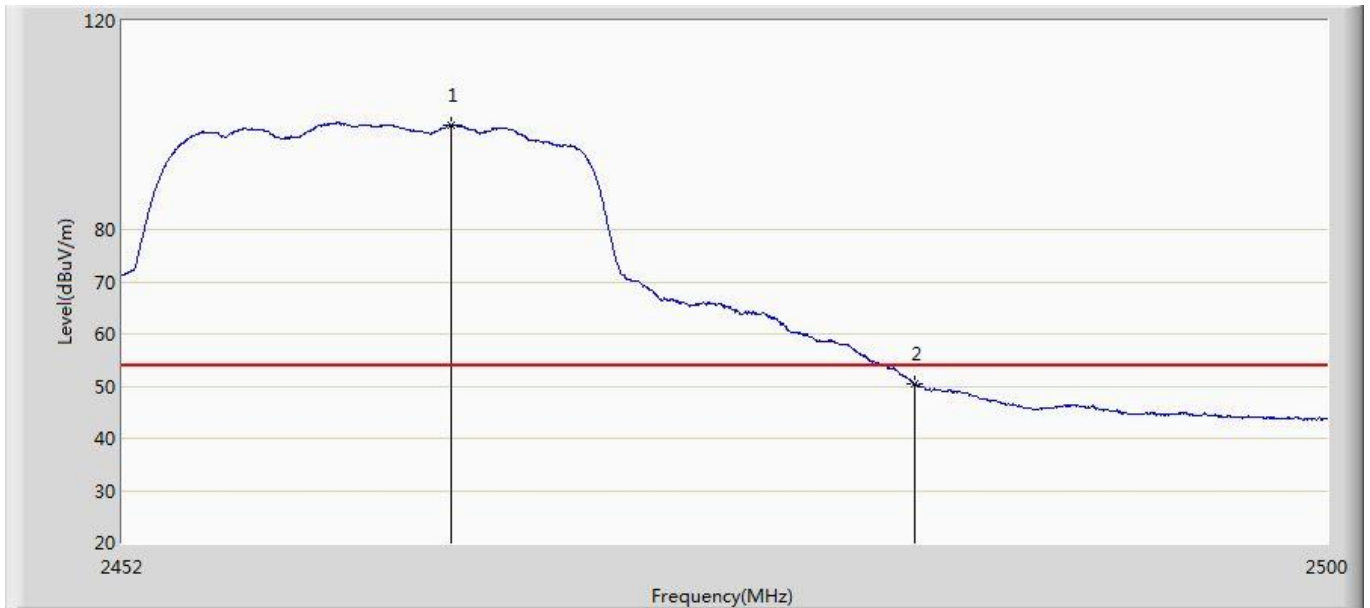

No	Mark	Frequency (MHz)	Measure Level (dBuV/m)	Reading Level (dBuV)	Over Limit (dB)	Limit (dBuV/m)	Factor (dB)	Type
1	*	2465.032	100.031	63.443	46.031	54.000	36.588	AV
2		2483.500	50.341	13.874	-3.659	54.000	36.467	AV

Site: AC5	Time: 2017/05/18- 11:21
Limit: FCC_Part15.209_RE(3m)	Margin: 0
Probe: Horn_3117_00167055(1-18GHz)	Polarity: Vertical
EUT:300Mbps Wireless N Nano Router	Power: AC 120V/60Hz
Note: Mode 2:Transmit at 2462MHz by 802.11G	

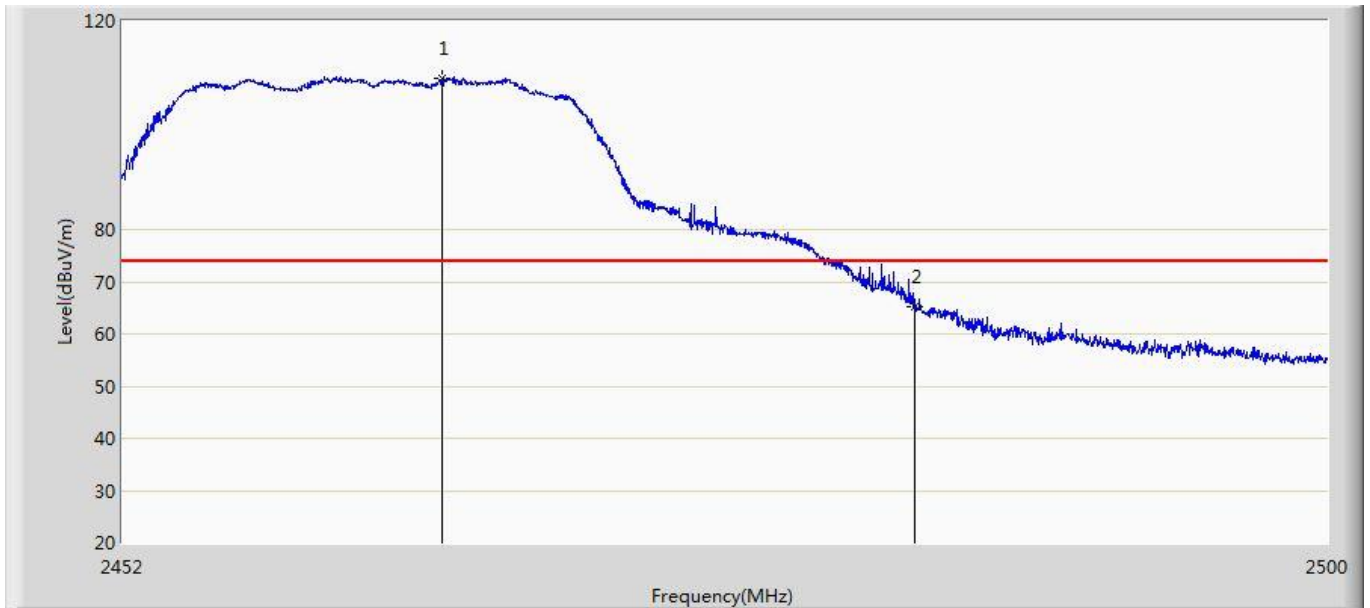

No	Mark	Frequency (MHz)	Measure Level (dBuV/m)	Reading Level (dBuV)	Over Limit (dB)	Limit (dBuV/m)	Factor (dB)	Type
1	*	2464.648	109.010	72.417	35.010	74.000	36.593	PK
2		2483.500	65.193	28.726	-8.807	74.000	36.467	PK

Site: AC5	Time: 2017/05/18- 18:09
Limit: FCC_Part15.209_RE(3m)	Margin: 0
Probe: Horn_3117_00167055(1-18GHz)	Polarity: Horizontal
EUT:300Mbps Wireless N Nano Router	Power: AC 120V/60Hz
Note: Mode 3:Transmit at 2412MHz by 802.11N20	

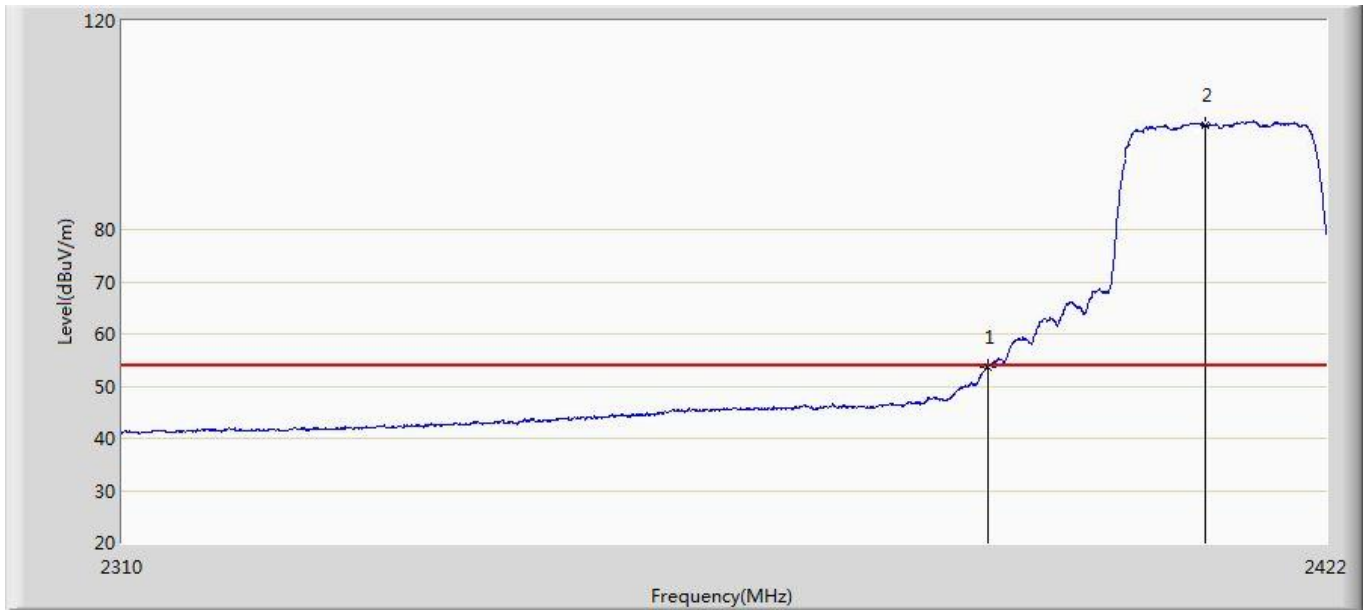

No	Mark	Frequency (MHz)	Measure Level (dBuV/m)	Reading Level (dBuV)	Over Limit (dB)	Limit (dBuV/m)	Factor (dB)	Type
1		2390.000	53.750	17.420	-0.250	54.000	36.329	AV
2	*	2410.576	99.995	63.668	45.995	54.000	36.328	AV

Site: AC5	Time: 2017/05/18- 18:15
Limit: FCC_Part15.209_RE(3m)	Margin: 0
Probe: Horn_3117_00167055(1-18GHz)	Polarity: Horizontal
EUT:300Mbps Wireless N Nano Router	Power: AC 120V/60Hz
Note: Mode 3:Transmit at 2412MHz by 802.11N20	

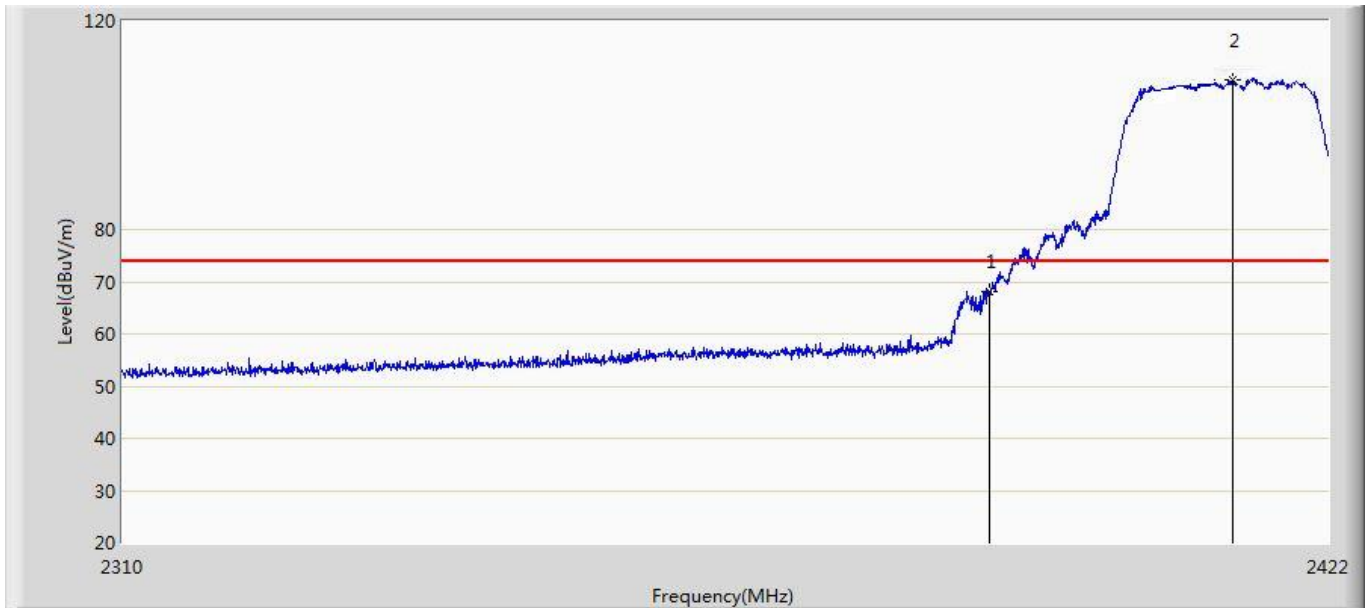

No	Mark	Frequency (MHz)	Measure Level (dBuV/m)	Reading Level (dBuV)	Over Limit (dB)	Limit (dBuV/m)	Factor (dB)	Type
1		2390.000	68.113	31.783	-5.887	74.000	36.329	PK
2	*	2412.984	110.375	74.016	36.375	74.000	36.358	PK

Site: AC5	Time: 2017/05/18- 18:17
Limit: FCC_Part15.209_RE(3m)	Margin: 0
Probe: Horn_3117_00167055(1-18GHz)	Polarity: Vertical
EUT:300Mbps Wireless N Nano Router	Power: AC 120V/60Hz
Note: Mode 3:Transmit at 2412MHz by 802.11N20	

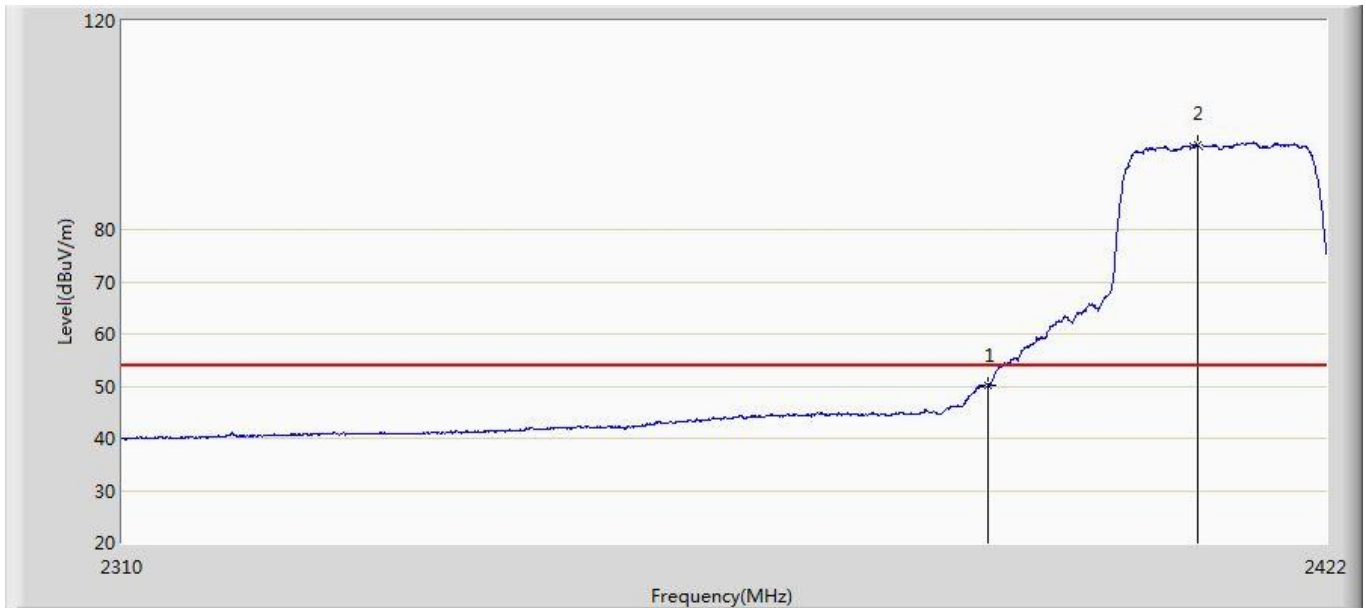

No	Mark	Frequency (MHz)	Measure Level (dBuV/m)	Reading Level (dBuV)	Over Limit (dB)	Limit (dBuV/m)	Factor (dB)	Type
1		2390.000	50.242	13.912	-3.758	54.000	36.329	AV
2	*	2409.792	98.875	62.548	44.875	54.000	36.328	AV

Site: AC5	Time: 2017/05/18- 18:30
Limit: FCC_Part15.209_RE(3m)	Margin: 0
Probe: Horn_3117_00167055(1-18GHz)	Polarity: Vertical
EUT:300Mbps Wireless N Nano Router	Power: AC 120V/60Hz
Note: Mode 3:Transmit at 2412MHz by 802.11N20	

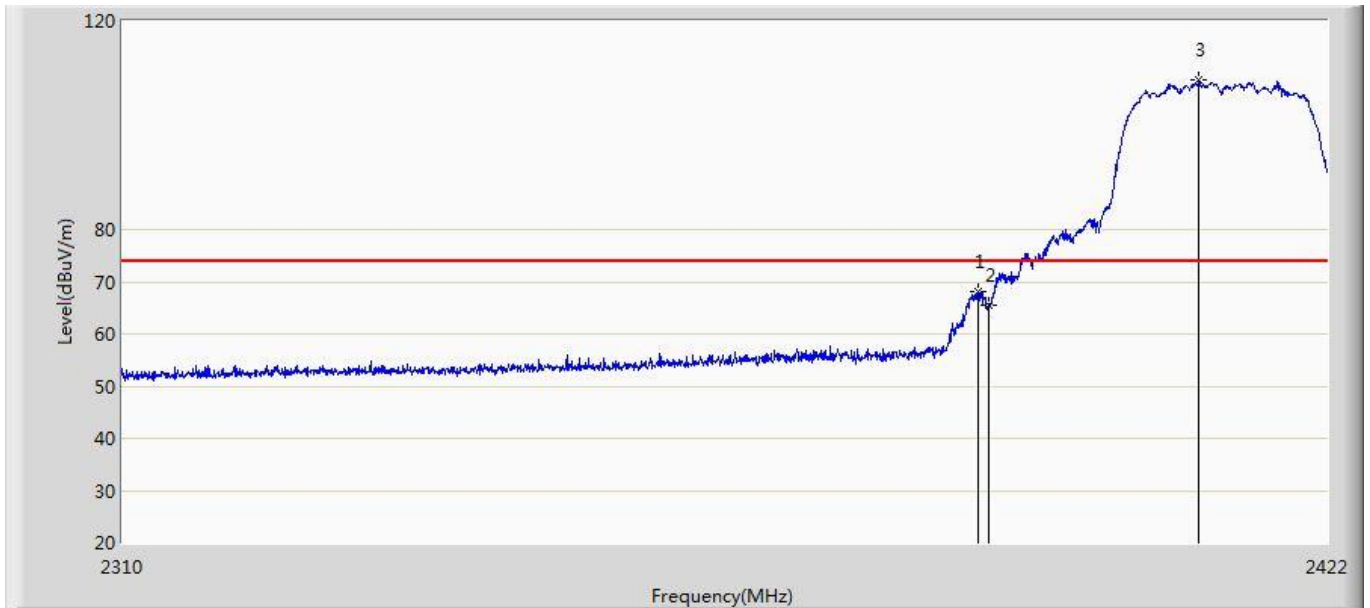

No	Mark	Frequency (MHz)	Measure Level (dBuV/m)	Reading Level (dBuV)	Over Limit (dB)	Limit (dBuV/m)	Factor (dB)	Type
1		2389.016	68.108	31.779	-5.892	74.000	36.330	PK
2		2390.000	65.469	29.139	-8.531	74.000	36.329	PK
3	*	2409.848	108.742	72.415	34.742	74.000	36.328	PK

Site: AC5	Time: 2017/07/07 - 12:11
Limit: FCC_Part15.209_RE(3m)	Margin: 0
Probe: Horn_3117_00167055(1-18GHz)	Polarity: Horizontal
EUT: 300Mbps Wireless N Nano Router	Power: AC 120V/60Hz
Note: Mode 3:Transmit at 2422MHz by 802.11N20	

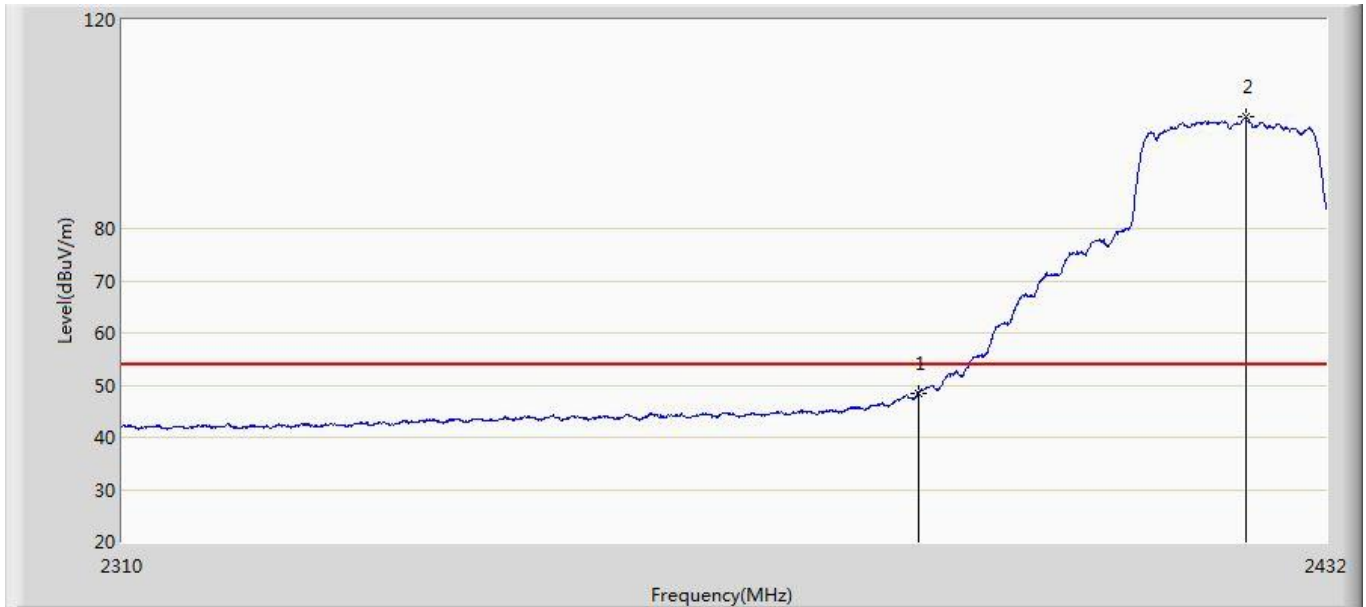

No	Mark	Frequency (MHz)	Measure Level (dBuV/m)	Reading Level (dBuV)	Over Limit (dB)	Limit (dBuV/m)	Factor (dB)	Type
1		2390.000	48.487	12.157	-5.513	54.000	36.329	AV
2	*	2423.704	101.485	64.956	47.485	54.000	36.529	AV



Site: AC5	Time: 2017/07/07 - 12:15
Limit: FCC_Part15.209_RE(3m)	Margin: 0
Probe: Horn_3117_00167055(1-18GHz)	Polarity: Horizontal
EUT: 300Mbps Wireless N Nano Router	Power: AC 120V/60Hz
Note: Mode 3:Transmit at 2422MHz by 802.11N20	

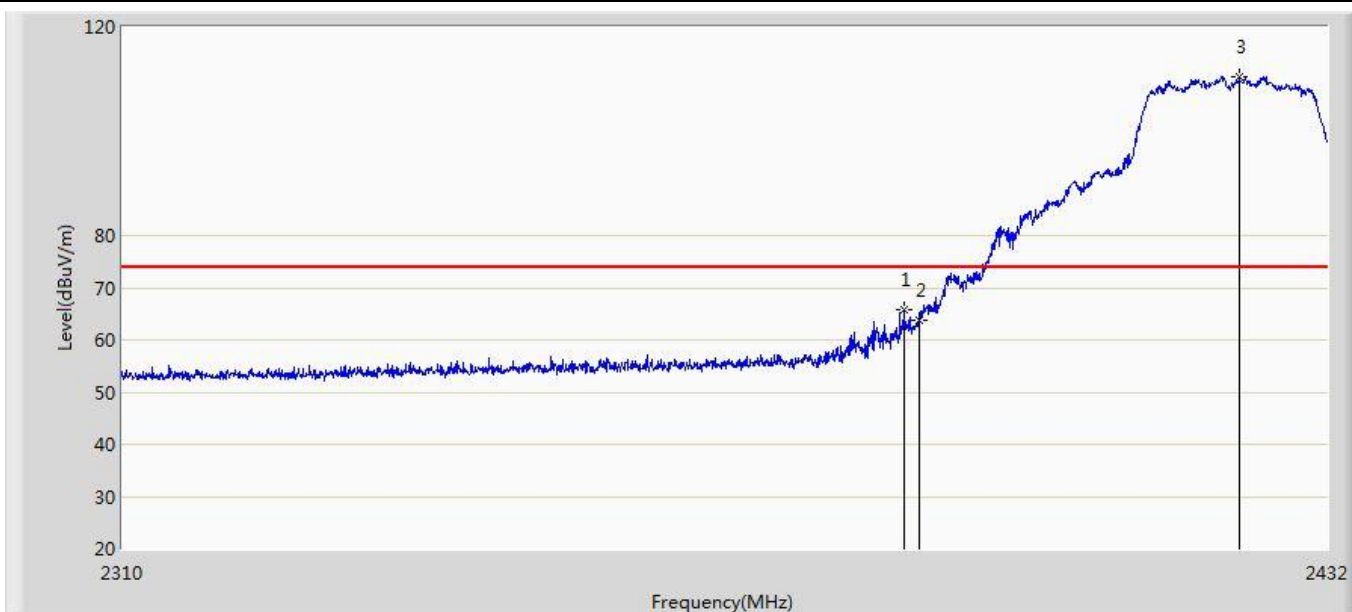

No	Mark	Frequency (MHz)	Measure Level (dBuV/m)	Reading Level (dBuV)	Over Limit (dB)	Limit (dBuV/m)	Factor (dB)	Type
1		2388.446	65.832	29.503	-8.168	74.000	36.329	PK
2		2390.000	63.805	27.475	-10.195	74.000	36.329	PK
3	*	2422.911	110.419	73.903	36.419	74.000	36.516	PK

Site: AC5	Time: 2017/07/07 - 12:20
Limit: FCC_Part15.209_RE(3m)	Margin: 0
Probe: Horn_3117_00167055(1-18GHz)	Polarity: Vertical
EUT: 300Mbps Wireless N Nano Router	Power: AC 120V/60Hz
Note: Mode 3:Transmit at 2422MHz by 802.11N20	

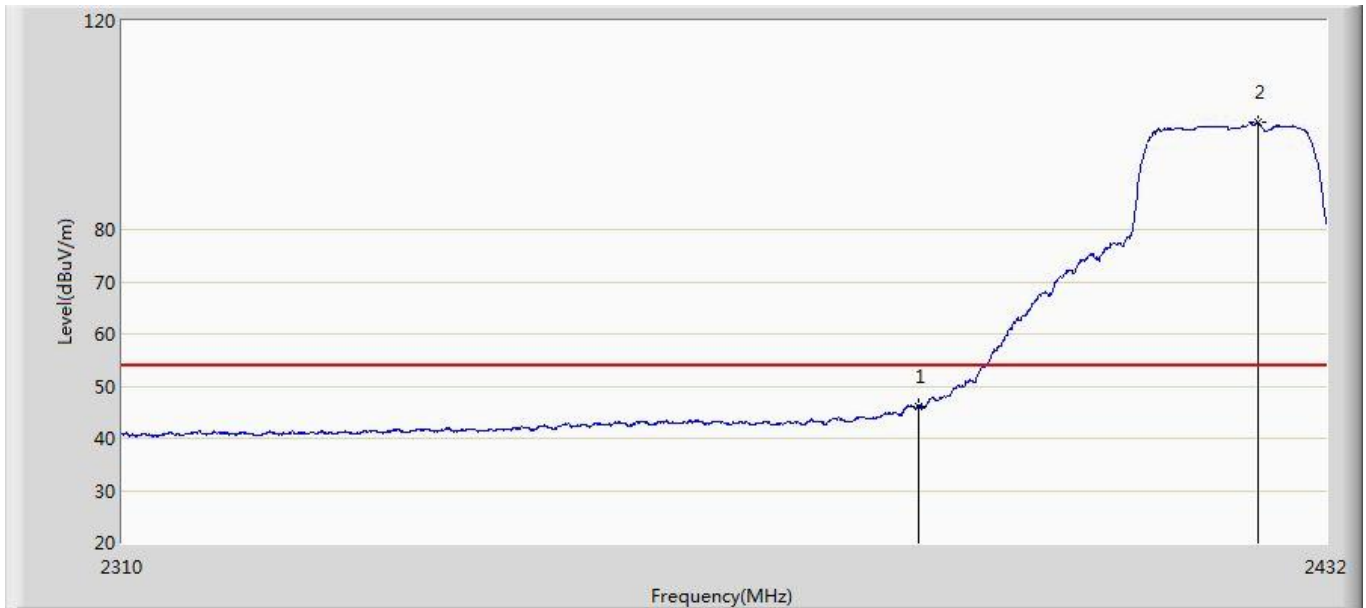

No	Mark	Frequency (MHz)	Measure Level (dBuV/m)	Reading Level (dBuV)	Over Limit (dB)	Limit (dBuV/m)	Factor (dB)	Type
1		2390.000	46.097	9.767	-7.903	54.000	36.329	AV
2	*	2424.924	100.664	64.116	46.664	54.000	36.548	AV

Site: AC5	Time: 2017/07/07 - 12:24
Limit: FCC_Part15.209_RE(3m)	Margin: 0
Probe: Horn_3117_00167055(1-18GHz)	Polarity: Vertical
EUT: 300Mbps Wireless N Nano Router	Power: AC 120V/60Hz
Note: Mode 3:Transmit at 2422MHz by 802.11N20	

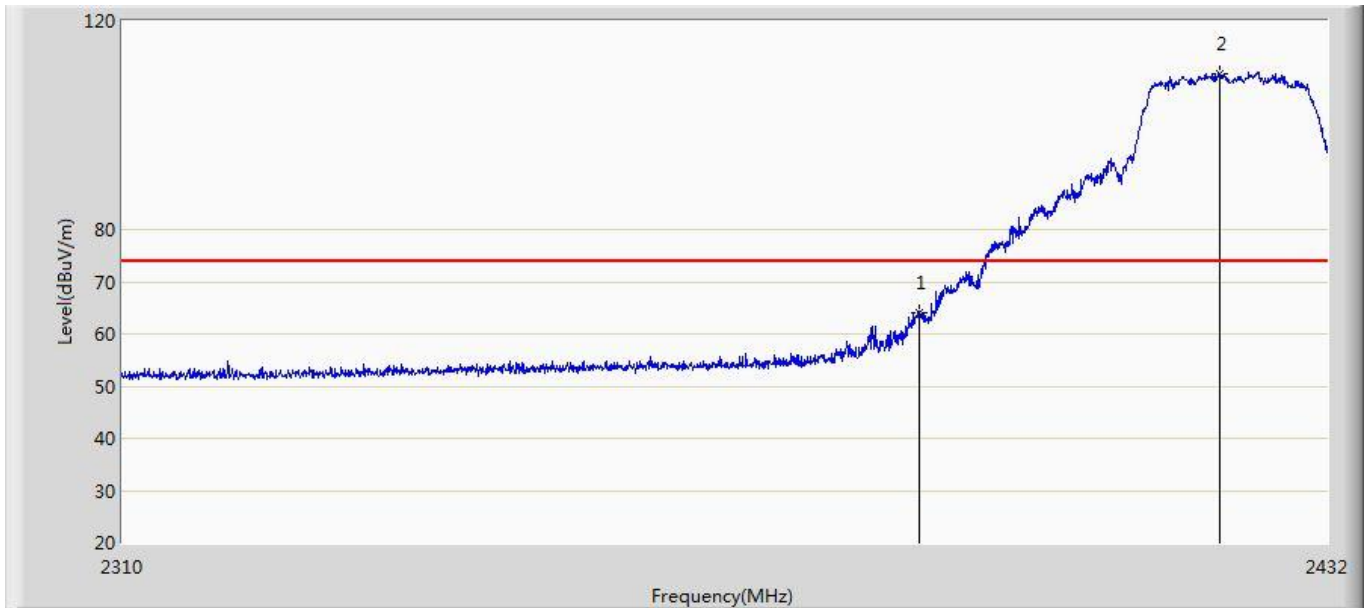

No	Mark	Frequency (MHz)	Measure Level (dBuV/m)	Reading Level (dBuV)	Over Limit (dB)	Limit (dBuV/m)	Factor (dB)	Type
1		2390.000	64.161	27.831	-9.839	74.000	36.329	PK
2	*	2420.837	109.986	73.503	35.986	74.000	36.483	PK

Site: AC5	Time: 2017/07/07 - 12:27
Limit: FCC_Part15.209_RE(3m)	Margin: 0
Probe: Horn_3117_00167055(1-18GHz)	Polarity: Horizontal
EUT: 300Mbps Wireless N Nano Router	Power: AC 120V/60Hz
Note: Mode 3:Transmit at 2452MHz by 802.11N20	

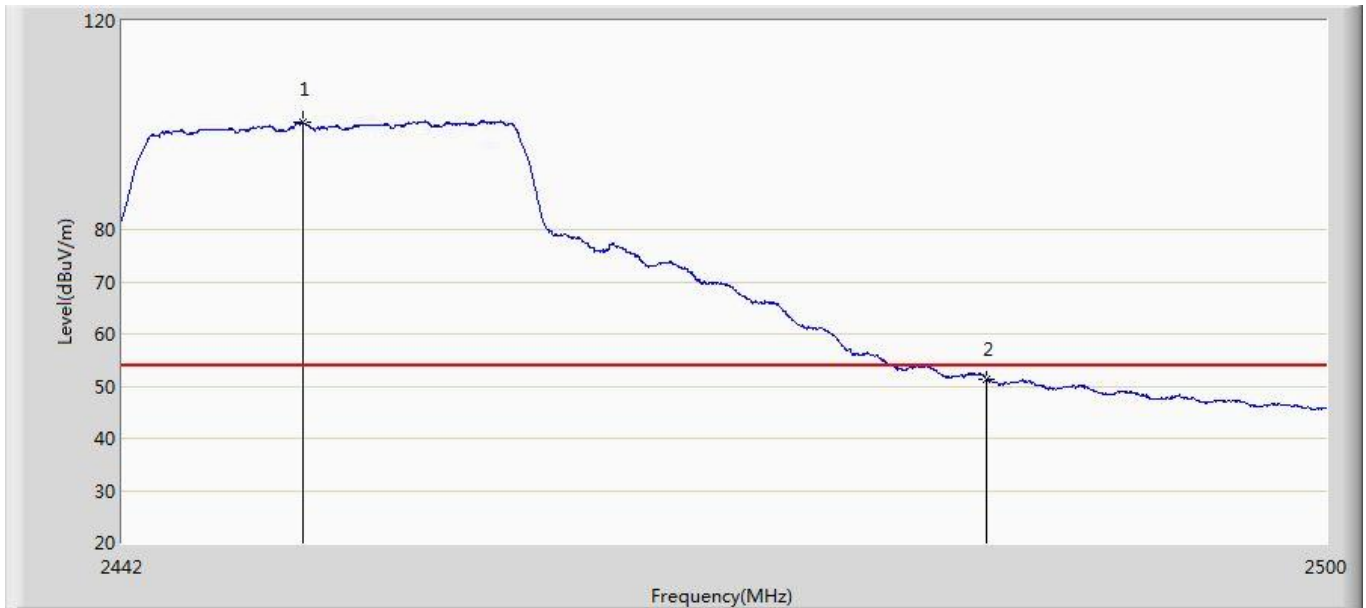

No	Mark	Frequency (MHz)	Measure Level (dBuV/m)	Reading Level (dBuV)	Over Limit (dB)	Limit (dBuV/m)	Factor (dB)	Type
1	*	2450.642	101.267	64.862	47.267	54.000	36.405	AV
2		2483.500	51.419	14.952	-2.581	54.000	36.467	AV

Site: AC5	Time: 2017/07/07 - 12:30
Limit: FCC_Part15.209_RE(3m)	Margin: 0
Probe: Horn_3117_00167055(1-18GHz)	Polarity: Horizontal
EUT: 300Mbps Wireless N Nano Router	Power: AC 120V/60Hz
Note: Mode 3:Transmit at 2452MHz by 802.11N20	

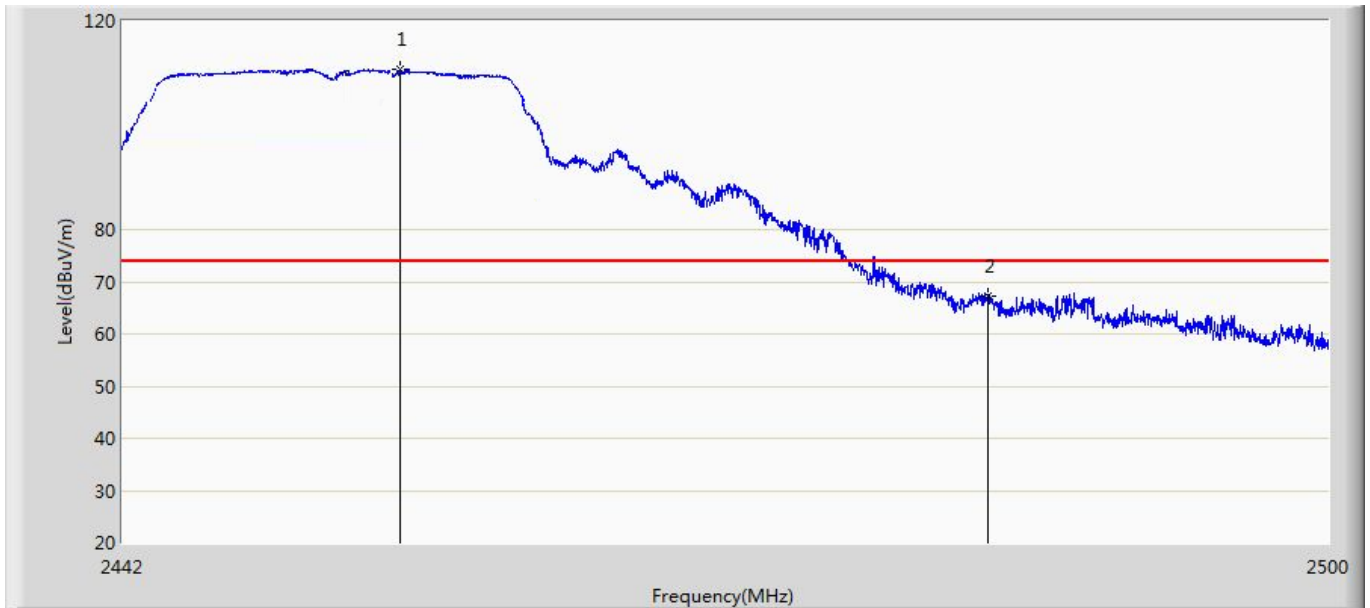

No	Mark	Frequency (MHz)	Measure Level (dBuV/m)	Reading Level (dBuV)	Over Limit (dB)	Limit (dBuV/m)	Factor (dB)	Type
1	*	2455.224	110.865	74.370	36.865	74.000	36.495	PK
2		2483.500	67.210	30.743	-6.790	74.000	36.467	PK

Site: AC5	Time: 2017/07/07 - 12:34
Limit: FCC_Part15.209_RE(3m)	Margin: 0
Probe: Horn_3117_00167055(1-18GHz)	Polarity: Vertical
EUT: 300Mbps Wireless N Nano Router	Power: AC 120V/60Hz
Note: Mode 3:Transmit at 2452MHz by 802.11N20	

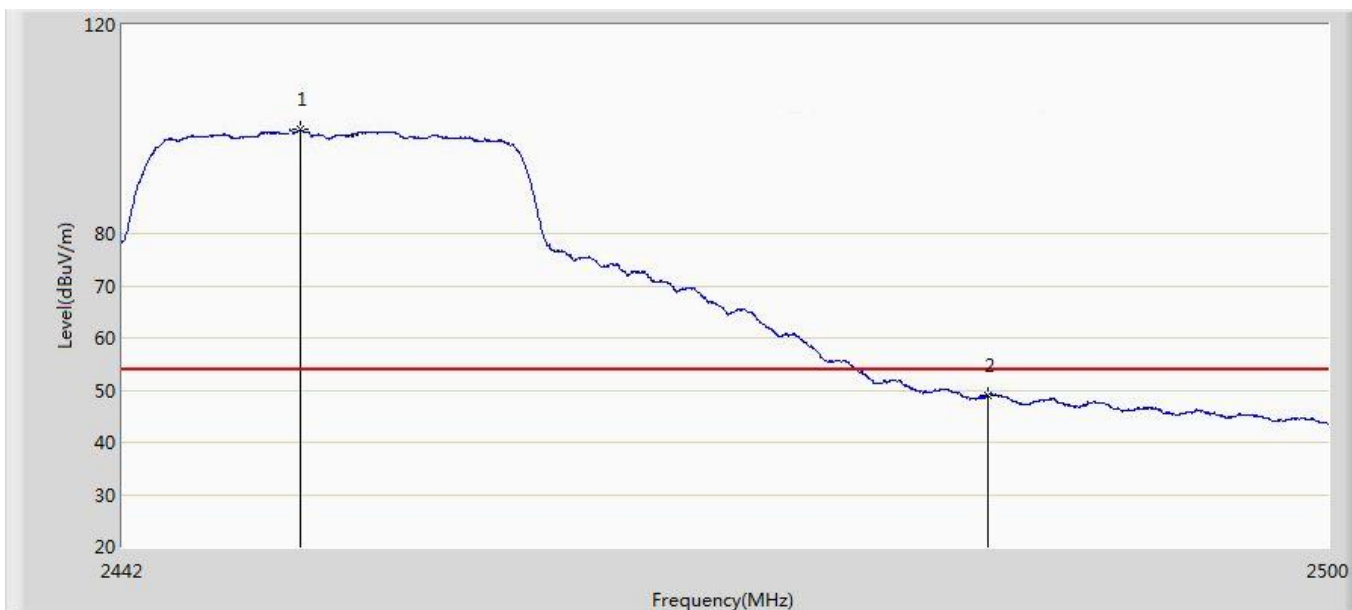

No	Mark	Frequency (MHz)	Measure Level (dBuV/m)	Reading Level (dBuV)	Over Limit (dB)	Limit (dBuV/m)	Factor (dB)	Type
1	*	2450.497	99.987	63.585	45.987	54.000	36.401	AV
2		2483.500	48.994	12.527	-5.006	54.000	36.467	AV

Site: AC5	Time: 2017/07/07 - 12:36
Limit: FCC_Part15.209_RE(3m)	Margin: 0
Probe: Horn_3117_00167055(1-18GHz)	Polarity: Vertical
EUT: 300Mbps Wireless N Nano Router	Power: AC 120V/60Hz
Note: Mode 3:Transmit at 2452MHz by 802.11N20	



No	Mark	Frequency (MHz)	Measure Level (dBuV/m)	Reading Level (dBuV)	Over Limit (dB)	Limit (dBuV/m)	Factor (dB)	Type
1	*	2452.875	109.875	73.426	35.875	74.000	36.448	PK
2		2483.500	63.876	27.409	-10.124	74.000	36.467	PK

Site: AC5	Time: 2017/05/18- 19:13
Limit: FCC_Part15.209_RE(3m)	Margin: 0
Probe: Horn_3117_00167055(1-18GHz)	Polarity: Horizontal
EUT:300Mbps Wireless N Nano Router	Power: AC 120V/60Hz
Note: Mode 3:Transmit at 2462MHz by 802.11N20	

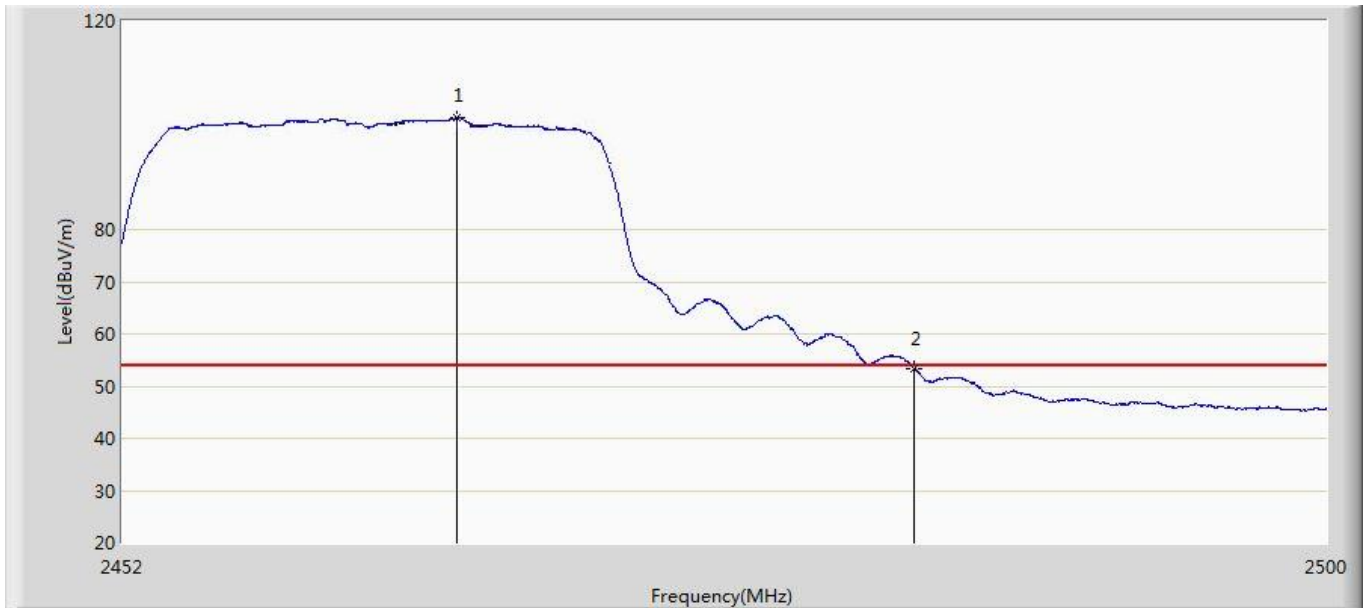

No	Mark	Frequency (MHz)	Measure Level (dBuV/m)	Reading Level (dBuV)	Over Limit (dB)	Limit (dBuV/m)	Factor (dB)	Type
1	*	2465.248	100.053	63.468	46.053	54.000	36.585	AV
2		2483.500	53.365	16.898	-0.635	54.000	36.467	AV



Site: AC5	Time: 2017/05/18- 19:15
Limit: FCC_Part15.209_RE(3m)	Margin: 0
Probe: Horn_3117_00167055(1-18GHz)	Polarity: Horizontal
EUT:300Mbps Wireless N Nano Router	Power: AC 120V/60Hz
Note: Mode 3:Transmit at 2462MHz by 802.11N20	

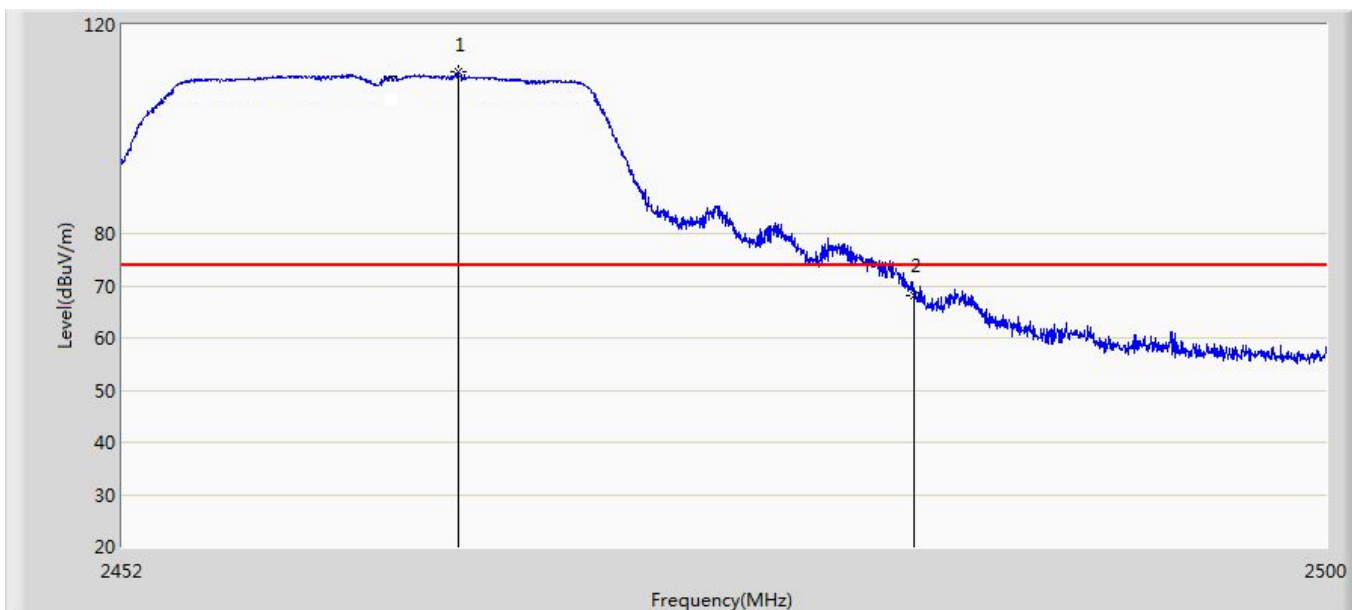

No	Mark	Frequency (MHz)	Measure Level (dBuV/m)	Reading Level (dBuV)	Over Limit (dB)	Limit (dBuV/m)	Factor (dB)	Type
1	*	2465.296	110.299	73.714	36.299	74.000	36.585	PK
2		2483.500	68.114	31.647	-5.886	74.000	36.467	PK

Site: AC5	Time: 2017/05/18- 19:17
Limit: FCC_Part15.209_RE(3m)	Margin: 0
Probe: Horn_3117_00167055(1-18GHz)	Polarity: Vertical
EUT:300Mbps Wireless N Nano Router	Power: AC 120V/60Hz
Note: Mode 3:Transmit at 2462MHz by 802.11N20	

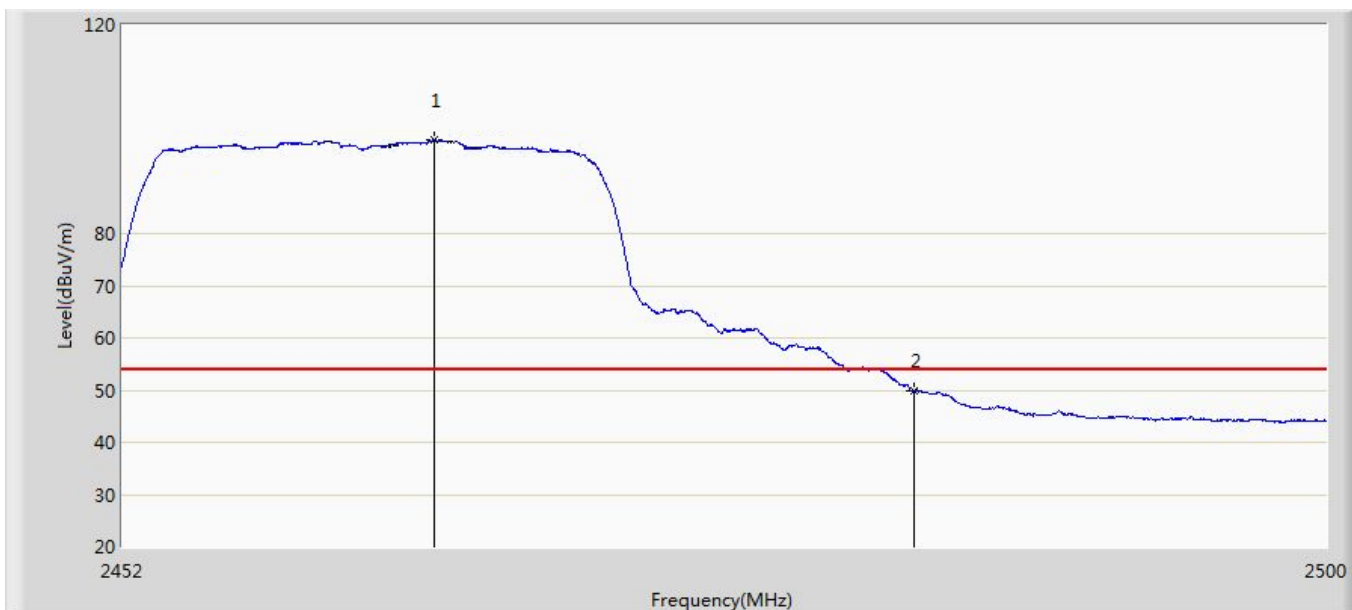

No	Mark	Frequency (MHz)	Measure Level (dBuV/m)	Reading Level (dBuV)	Over Limit (dB)	Limit (dBuV/m)	Factor (dB)	Type
1	*	2464.360	99.722	63.125	45.722	54.000	36.597	AV
2		2483.500	49.986	13.519	-4.014	54.000	36.467	AV

Site: AC5	Time: 2017/05/18- 19:19
Limit: FCC_Part15.209_RE(3m)	Margin: 0
Probe: Horn_3117_00167055(1-18GHz)	Polarity: Vertical
EUT:300Mbps Wireless N Nano Router	Power: AC 120V/60Hz
Note: Mode 3:Transmit at 2462MHz by 802.11N20	

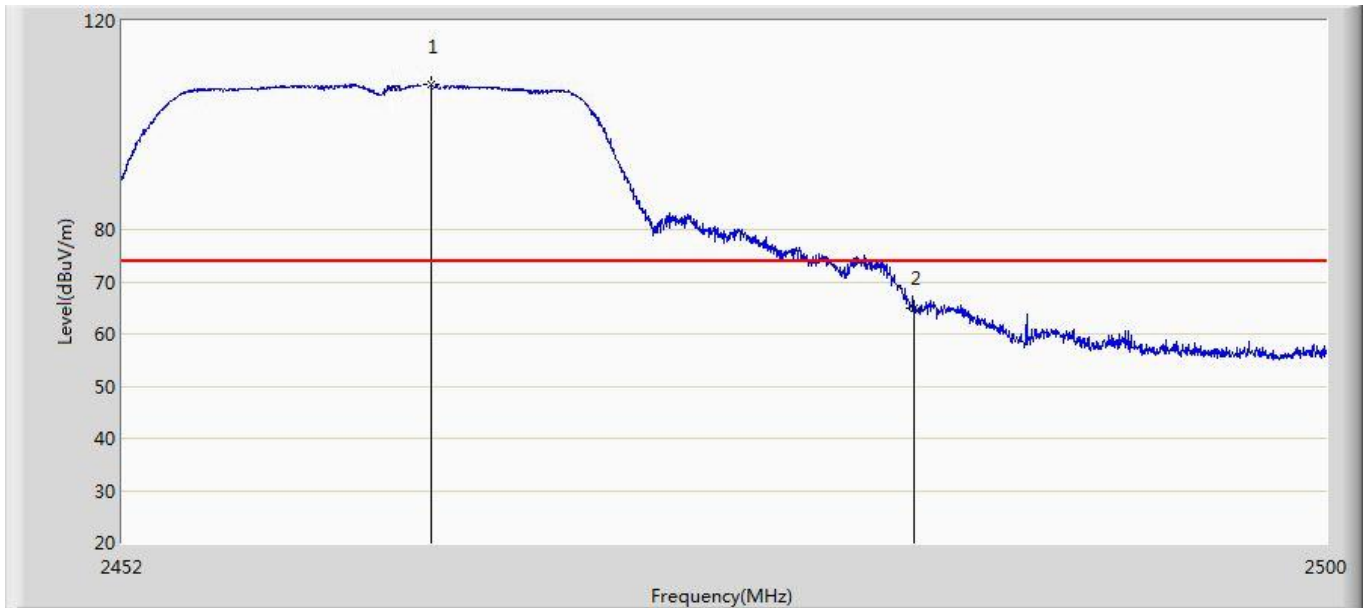

No	Mark	Frequency (MHz)	Measure Level (dBuV/m)	Reading Level (dBuV)	Over Limit (dB)	Limit (dBuV/m)	Factor (dB)	Type
1	*	2464.264	109.381	72.782	35.381	74.000	36.599	PK
2		2483.500	64.788	28.321	-9.212	74.000	36.467	PK

Site: AC5	Time: 2017/05/18- 19:23
Limit: FCC_Part15.209_RE(3m)	Margin: 0
Probe: Horn_3117_00167055(1-18GHz)	Polarity: Horizontal
EUT:300Mbps Wireless N Nano Router	Power: AC 120V/60Hz
Note: Mode 4:Transmit at 2422MHz by 802.11N40	

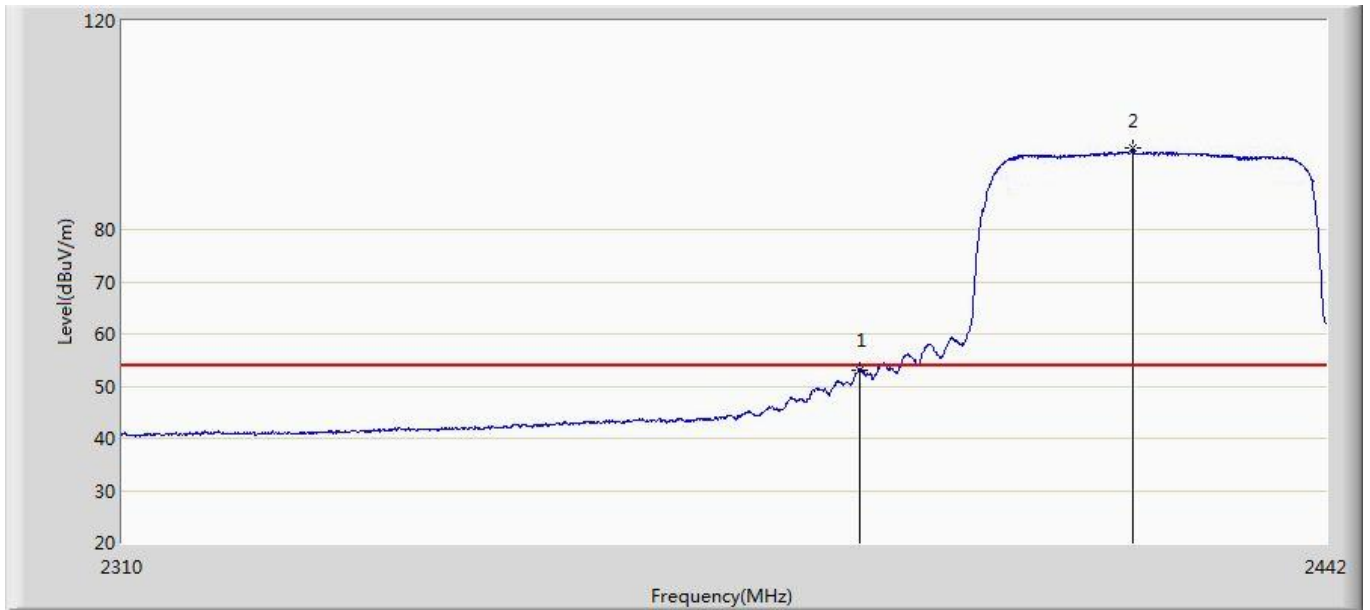

No	Mark	Frequency (MHz)	Measure Level (dBuV/m)	Reading Level (dBuV)	Over Limit (dB)	Limit (dBuV/m)	Factor (dB)	Type
1		2390.000	53.027	16.697	-0.973	54.000	36.329	AV
2	*	2420.352	97.264	60.788	43.264	54.000	36.476	AV

Site: AC5	Time: 2017/05/18- 19:28
Limit: FCC_Part15.209_RE(3m)	Margin: 0
Probe: Horn_3117_00167055(1-18GHz)	Polarity: Horizontal
EUT:300Mbps Wireless N Nano Router	Power: AC 120V/60Hz
Note: Mode 4:Transmit at 2422MHz by 802.11N40	

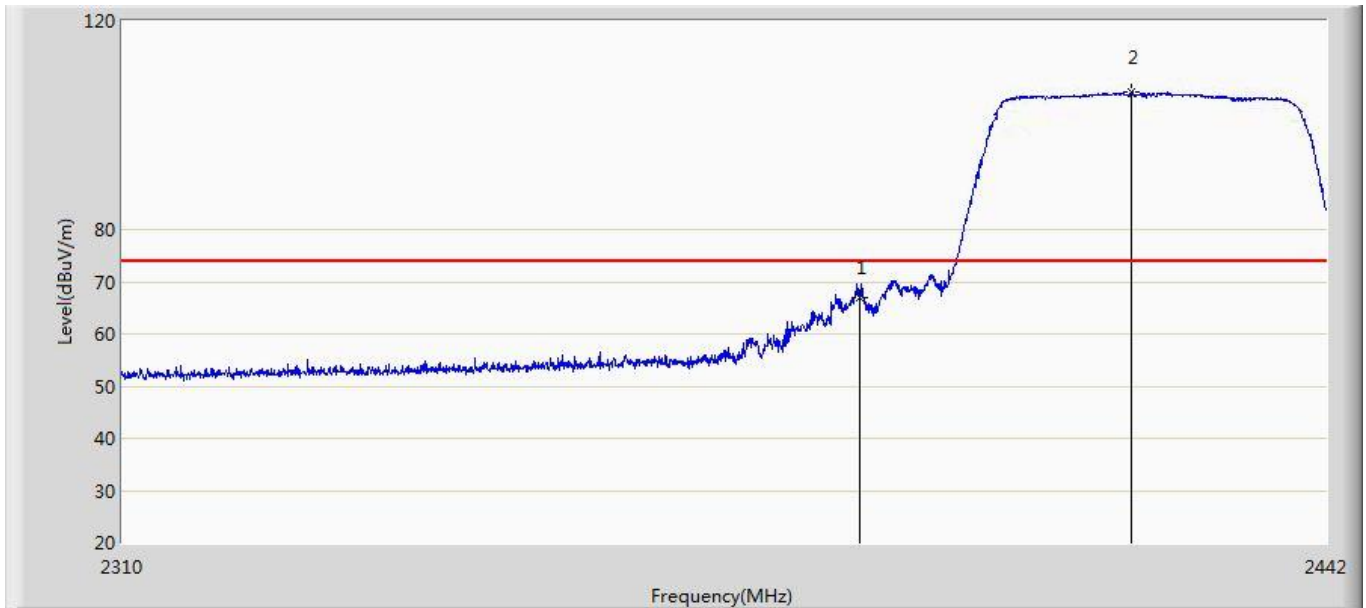

No	Mark	Frequency (MHz)	Measure Level (dBuV/m)	Reading Level (dBuV)	Over Limit (dB)	Limit (dBuV/m)	Factor (dB)	Type
1		2390.000	67.092	30.762	-6.908	74.000	36.329	PK
2	*	2420.154	107.312	70.840	33.312	74.000	36.472	PK

Site: AC5	Time: 2017/05/18- 19:30
Limit: FCC_Part15.209_RE(3m)	Margin: 0
Probe: Horn_3117_00167055(1-18GHz)	Polarity: Vertical
EUT:300Mbps Wireless N Nano Router	Power: AC 120V/60Hz
Note: Mode 4:Transmit at 2422MHz by 802.11N40	

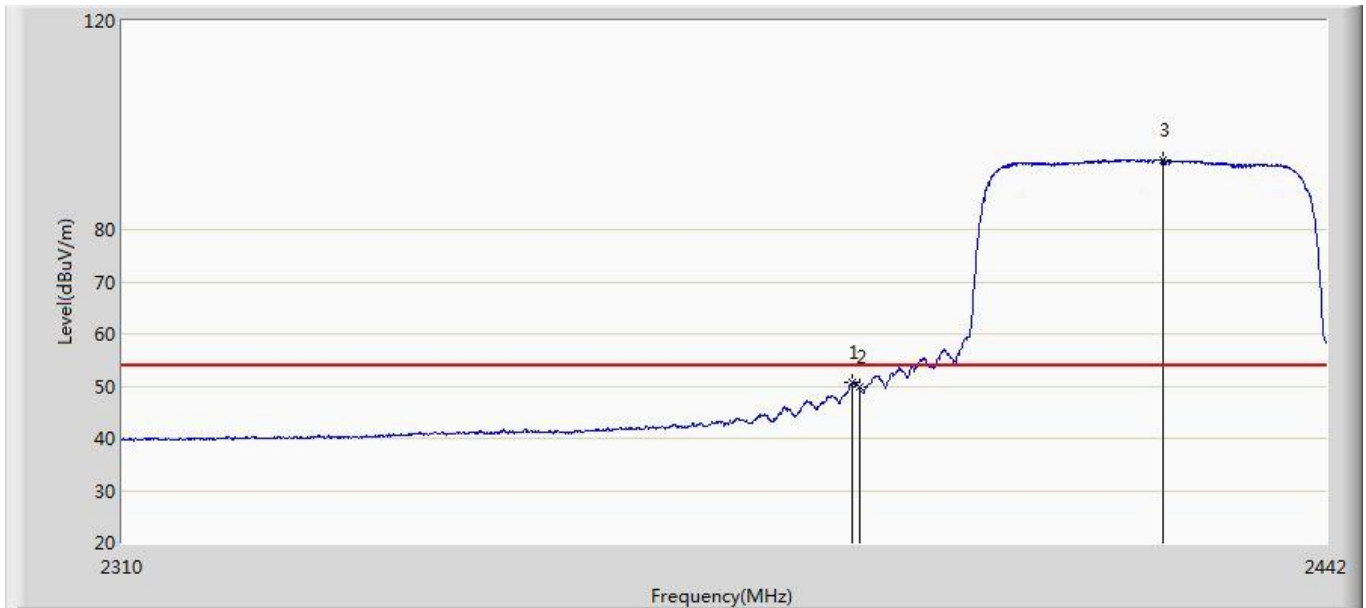

No	Mark	Frequency (MHz)	Measure Level (dBuV/m)	Reading Level (dBuV)	Over Limit (dB)	Limit (dBuV/m)	Factor (dB)	Type
1		2389.200	50.600	14.271	-3.400	54.000	36.329	AV
2		2390.000	49.823	13.493	-4.177	54.000	36.329	AV
3	*	2423.784	93.191	56.661	39.191	54.000	36.530	AV

Site: AC5	Time: 2017/05/18- 19:32
Limit: FCC_Part15.209_RE(3m)	Margin: 0
Probe: Horn_3117_00167055(1-18GHz)	Polarity: Vertical
EUT:300Mbps Wireless N Nano Router	Power: AC 120V/60Hz
Note: Mode 4:Transmit at 2422MHz by 802.11N40	

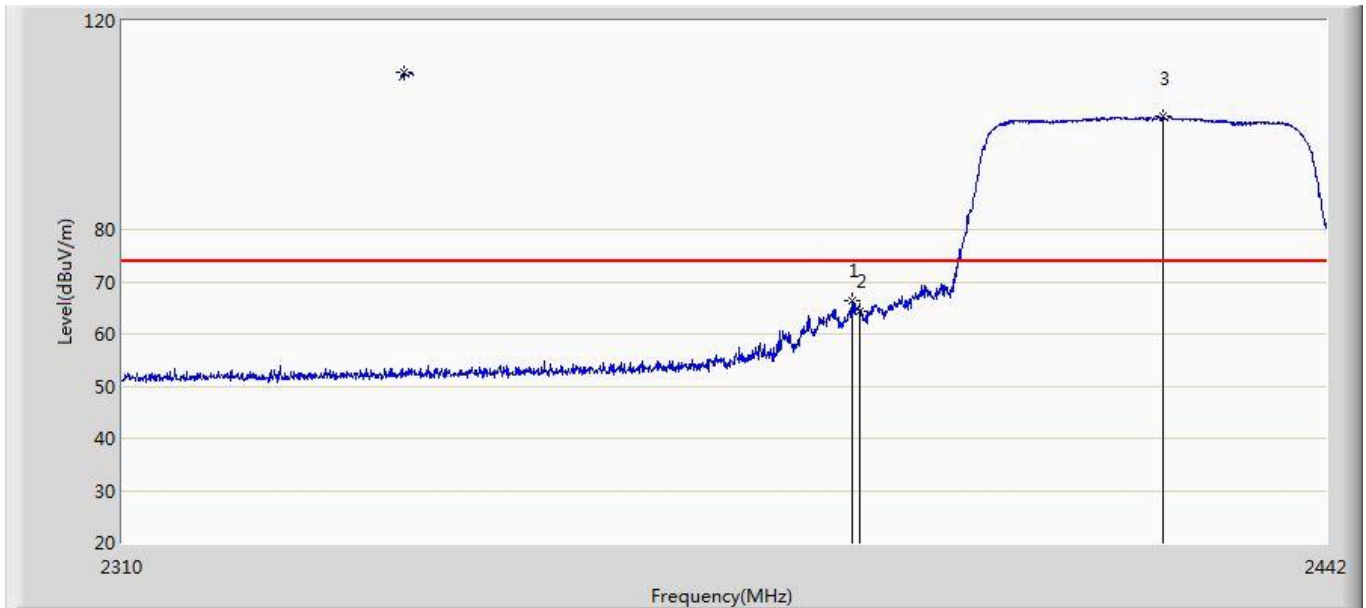

No	Mark	Frequency (MHz)	Measure Level (dBuV/m)	Reading Level (dBuV)	Over Limit (dB)	Limit (dBuV/m)	Factor (dB)	Type
1		2389.266	66.404	30.075	-7.596	74.000	36.329	PK
2		2390.000	64.398	28.068	-9.602	74.000	36.329	PK
3	*	2423.718	103.153	66.624	29.153	74.000	36.529	PK

Site: AC5	Time: 2017/07/07 - 12:45
Limit: FCC_Part15.209_RE(3m)	Margin: 0
Probe: Horn_3117_00167055(1-18GHz)	Polarity: Horizontal
EUT: 300Mbps Wireless N Nano Router	Power: AC 120V/60Hz
Note: Mode 4:Transmit at 2427MHz by 802.11N40	

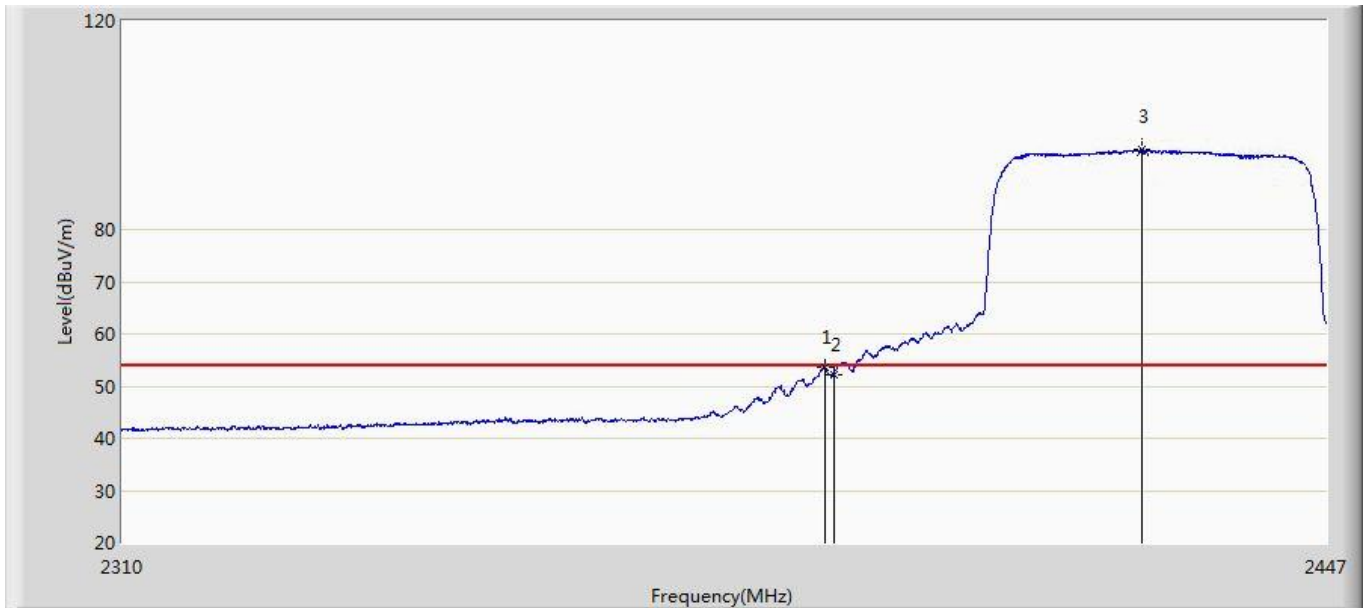

No	Mark	Frequency (MHz)	Measure Level (dBuV/m)	Reading Level (dBuV)	Over Limit (dB)	Limit (dBuV/m)	Factor (dB)	Type
1		2388.980	53.511	17.182	-0.489	54.000	36.330	AV
2		2390.000	52.090	15.760	-1.910	54.000	36.329	AV
3	*	2425.628	95.894	59.335	41.894	54.000	36.559	AV



Site: AC5	Time: 2017/07/07 - 12:55
Limit: FCC_Part15.209_RE(3m)	Margin: 0
Probe: Horn_3117_00167055(1-18GHz)	Polarity: Horizontal
EUT: 300Mbps Wireless N Nano Router	Power: AC 120V/60Hz
Note: Mode 4:Transmit at 2427MHz by 802.11N40	

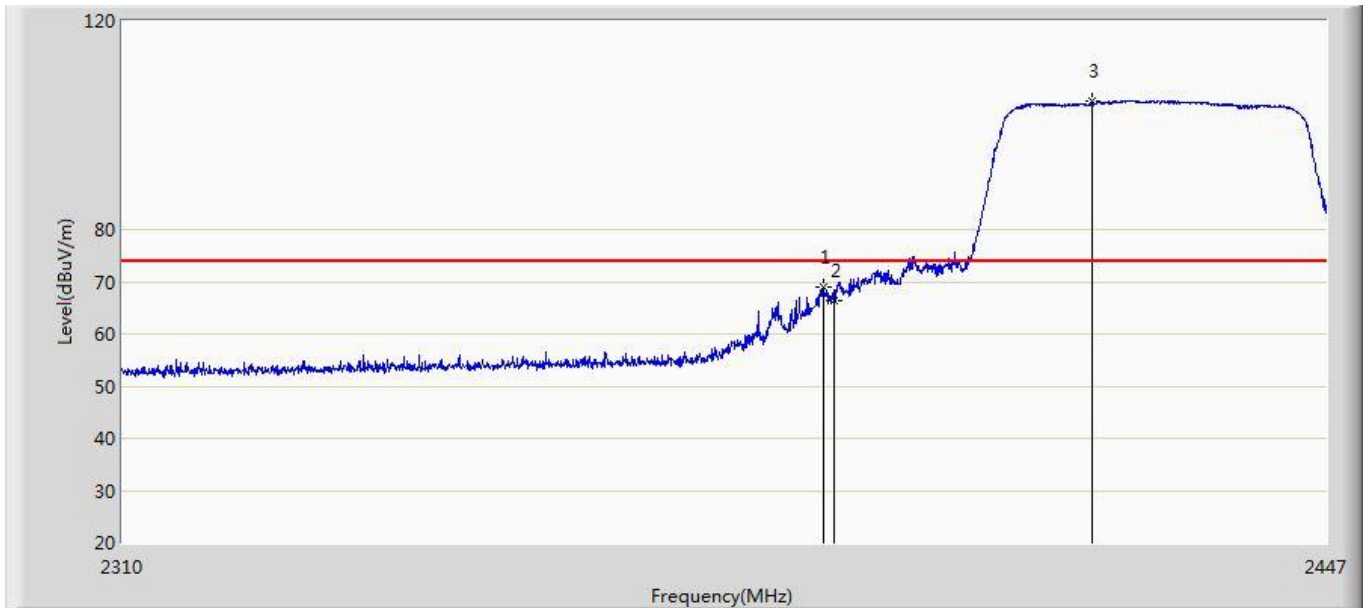

No	Mark	Frequency (MHz)	Measure Level (dBuV/m)	Reading Level (dBuV)	Over Limit (dB)	Limit (dBuV/m)	Factor (dB)	Type
1		2388.844	69.015	32.686	-4.985	74.000	36.330	PK
2		2390.000	66.317	29.987	-7.683	74.000	36.329	PK
3	*	2419.805	104.696	68.229	30.696	74.000	36.467	PK

Site: AC5	Time: 2017/07/07 - 12:57
Limit: FCC_Part15.209_RE(3m)	Margin: 0
Probe: Horn_3117_00167055(1-18GHz)	Polarity: Vertical
EUT: 300Mbps Wireless N Nano Router	Power: AC 120V/60Hz
Note: Mode 4:Transmit at 2427MHz by 802.11N40	

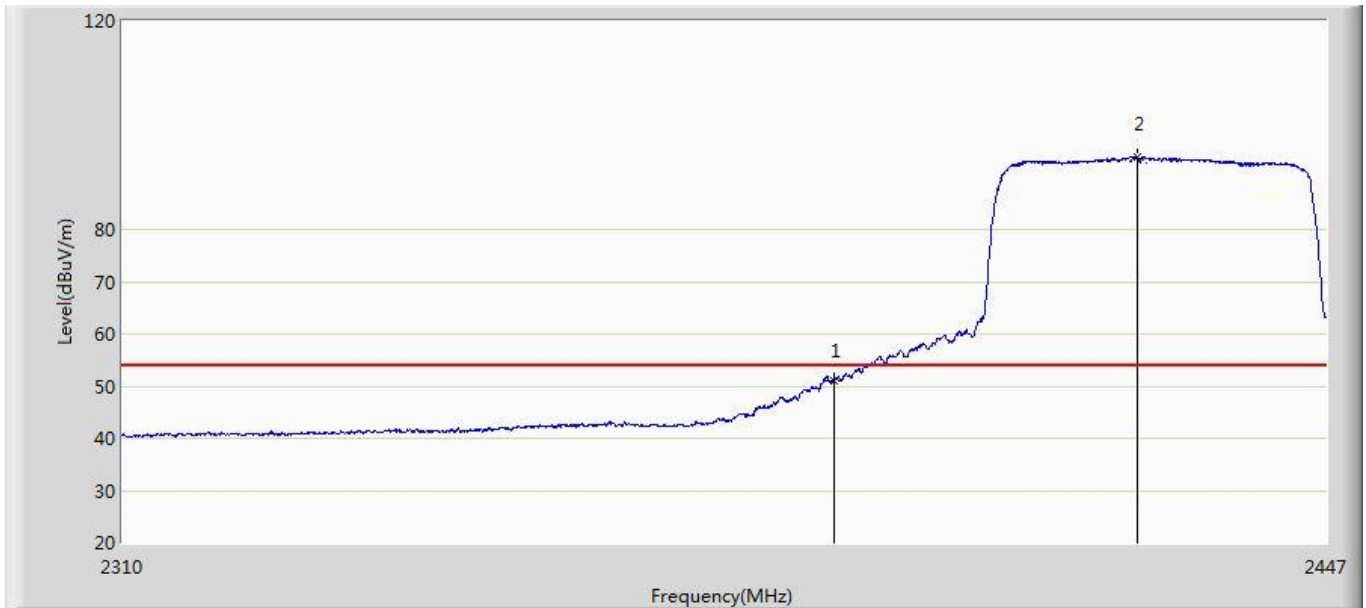

No	Mark	Frequency (MHz)	Measure Level (dBuV/m)	Reading Level (dBuV)	Over Limit (dB)	Limit (dBuV/m)	Factor (dB)	Type
1		2390.000	51.054	14.724	-2.946	54.000	36.329	AV
2	*	2424.943	94.390	57.842	40.390	54.000	36.548	AV

Site: AC5	Time: 2017/07/07 - 13:05
Limit: FCC_Part15.209_RE(3m)	Margin: 0
Probe: Horn_3117_00167055(1-18GHz)	Polarity: Vertical
EUT: 300Mbps Wireless N Nano Router	Power: AC 120V/60Hz
Note: Mode 4:Transmit at 2427MHz by 802.11N40	

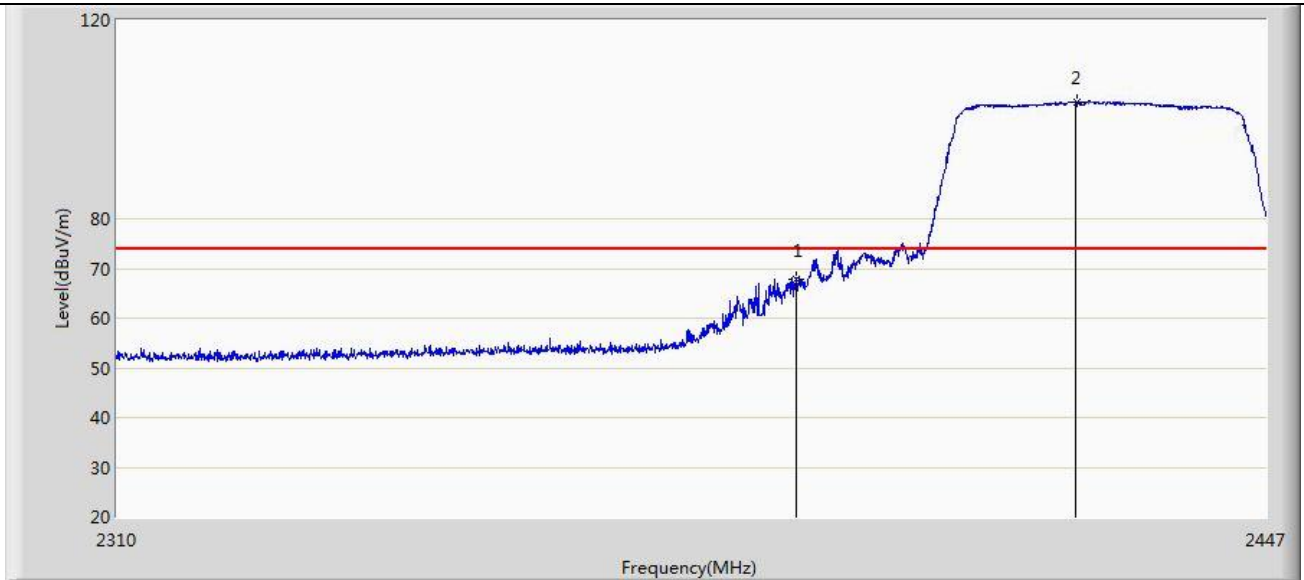

No	Mark	Frequency (MHz)	Measure Level (dBuV/m)	Reading Level (dBuV)	Over Limit (dB)	Limit (dBuV/m)	Factor (dB)	Type
1		2390.000	67.958	31.629	-6.042	74.000	36.329	PK
2	*	2423.847	104.384	67.853	30.384	74.000	36.531	PK

Site: AC5	Time: 2017/07/07 - 13:06
Limit: FCC_Part15.209_RE(3m)	Margin: 0
Probe: Horn_3117_00167055(1-18GHz)	Polarity: Horizontal
EUT: 300Mbps Wireless N Nano Router	Power: AC 120V/60Hz
Note: Mode 4:Transmit at 2447MHz by 802.11N40	

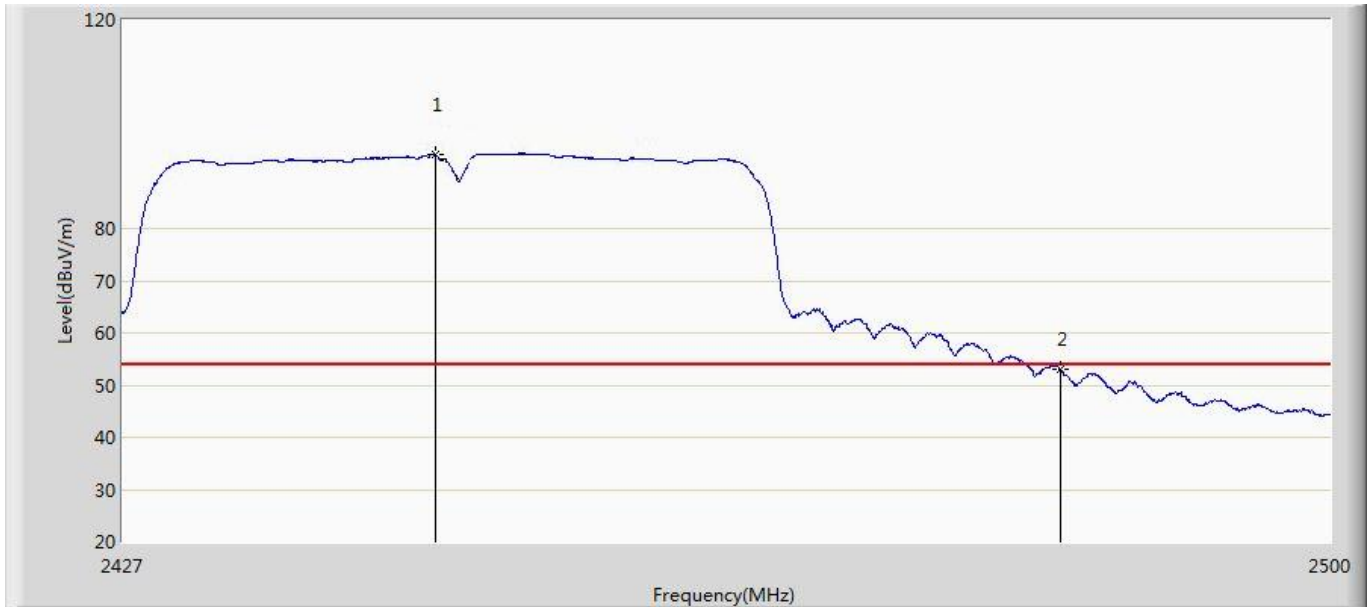

No	Mark	Frequency (MHz)	Measure Level (dBuV/m)	Reading Level (dBuV)	Over Limit (dB)	Limit (dBuV/m)	Factor (dB)	Type
1	*	2445.725	97.862	61.555	43.862	54.000	36.307	AV
2		2483.500	52.974	16.507	-1.026	54.000	36.467	AV

Site: AC5	Time: 2017/07/07 - 13:11
Limit: FCC_Part15.209_RE(3m)	Margin: 0
Probe: Horn_3117_00167055(1-18GHz)	Polarity: Horizontal
EUT: 300Mbps Wireless N Nano Router	Power: AC 120V/60Hz
Note: Mode 4:Transmit at 2447MHz by 802.11N40	

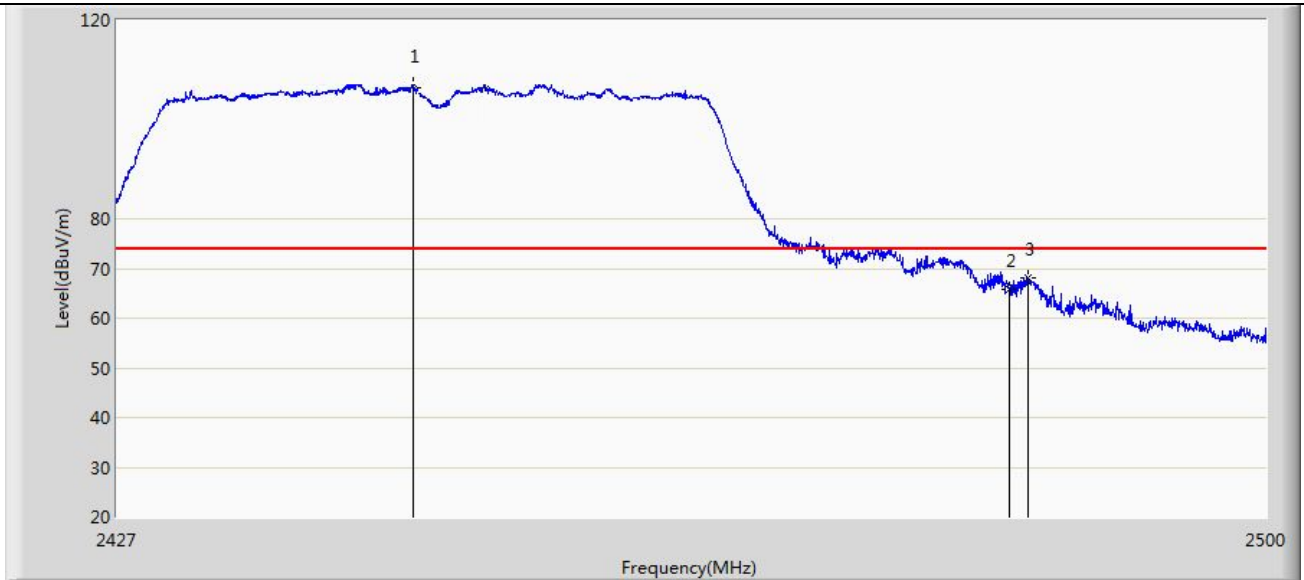

No	Mark	Frequency (MHz)	Measure Level (dBuV/m)	Reading Level (dBuV)	Over Limit (dB)	Limit (dBuV/m)	Factor (dB)	Type
1	*	2445.615	106.825	70.520	32.825	74.000	36.305	PK
2		2483.500	65.931	29.464	-8.069	74.000	36.467	PK
3		2484.707	68.085	31.600	-5.915	74.000	36.485	PK

Site: AC5	Time: 2017/07/07 - 13:14
Limit: FCC_Part15.209_RE(3m)	Margin: 0
Probe: Horn_3117_00167055(1-18GHz)	Polarity: Vertical
EUT: 300Mbps Wireless N Nano Router	Power: AC 120V/60Hz
Note: Mode 4:Transmit at 2447MHz by 802.11N40	

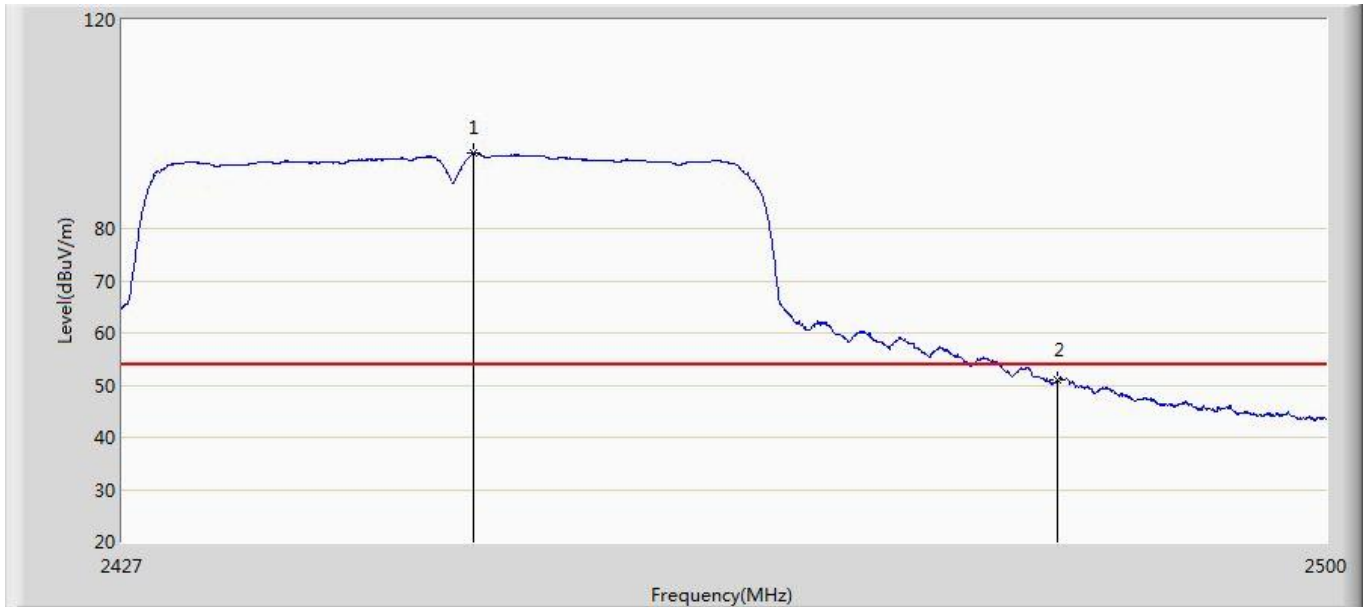

No	Mark	Frequency (MHz)	Measure Level (dBuV/m)	Reading Level (dBuV)	Over Limit (dB)	Limit (dBuV/m)	Factor (dB)	Type
1	*	2448.134	94.723	58.368	40.723	54.000	36.355	AV
2		2483.500	50.969	14.502	-3.031	54.000	36.467	AV

Site: AC5	Time: 2017/07/07 - 13:16
Limit: FCC_Part15.209_RE(3m)	Margin: 0
Probe: Horn_3117_00167055(1-18GHz)	Polarity: Vertical
EUT: 300Mbps Wireless N Nano Router	Power: AC 120V/60Hz
Note: Mode 4:Transmit at 2447MHz by 802.11N40	

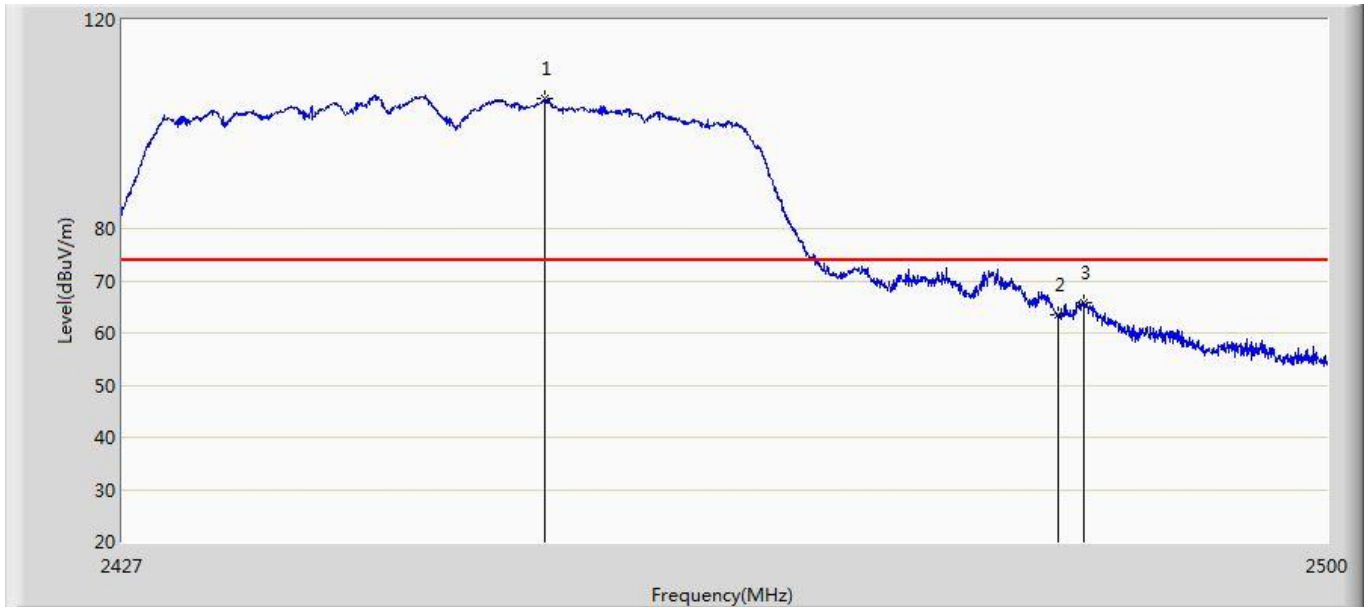

No	Mark	Frequency (MHz)	Measure Level (dBuV/m)	Reading Level (dBuV)	Over Limit (dB)	Limit (dBuV/m)	Factor (dB)	Type
1	*	2452.404	104.938	68.499	30.938	74.000	36.440	PK
2		2483.500	63.554	27.087	-10.446	74.000	36.467	PK
3		2485.108	65.904	29.413	-8.096	74.000	36.491	PK

Site: AC5	Time: 2017/05/18- 19:50
Limit: FCC_Part15.209_RE(3m)	Margin: 0
Probe: Horn_3117_00167055(1-18GHz)	Polarity: Horizontal
EUT:300Mbps Wireless N Nano Router	Power: AC 120V/60Hz
Note: Mode 4:Transmit at 2452MHz by 802.11N40	

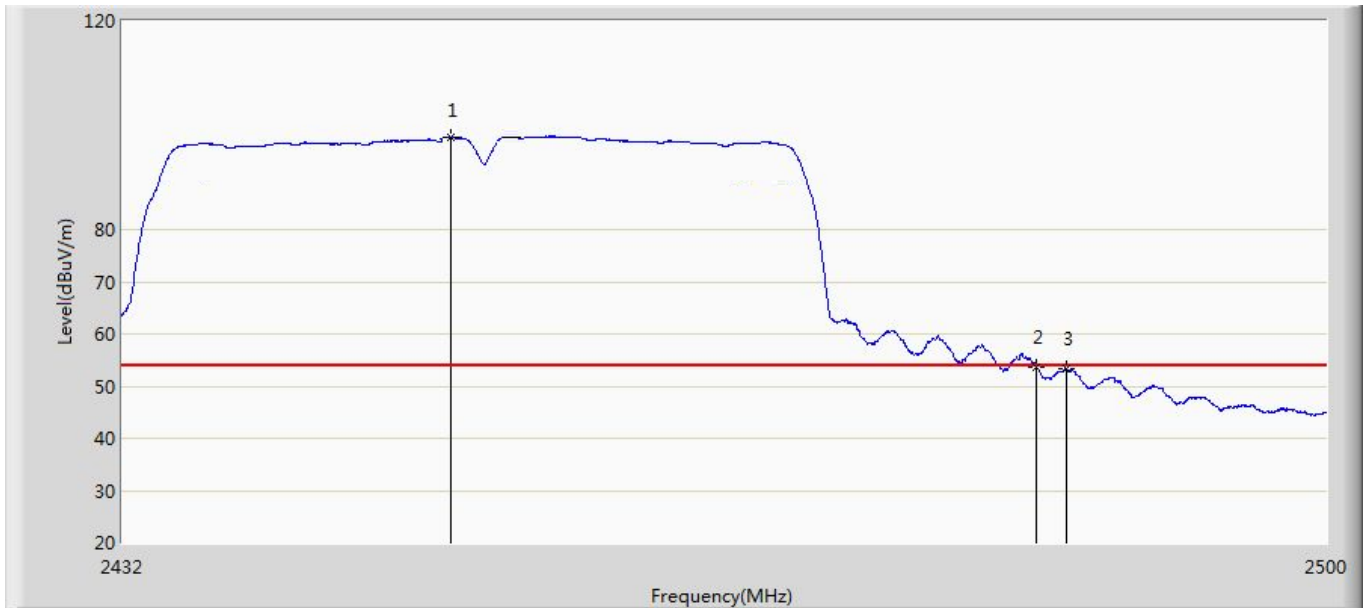

No	Mark	Frequency (MHz)	Measure Level (dBuV/m)	Reading Level (dBuV)	Over Limit (dB)	Limit (dBuV/m)	Factor (dB)	Type
1	*	2450.394	96.975	60.575	42.975	54.000	36.399	AV
2		2483.500	53.497	17.030	-0.503	54.000	36.467	AV
3		2485.142	53.378	16.887	-0.622	54.000	36.491	AV



Site: AC5	Time: 2017/05/18- 19:54
Limit: FCC_Part15.209_RE(3m)	Margin: 0
Probe: Horn_3117_00167055(1-18GHz)	Polarity: Horizontal
EUT:300Mbps Wireless N Nano Router	Power: AC 120V/60Hz
Note: Mode 4:Transmit at 2452MHz by 802.11N40	

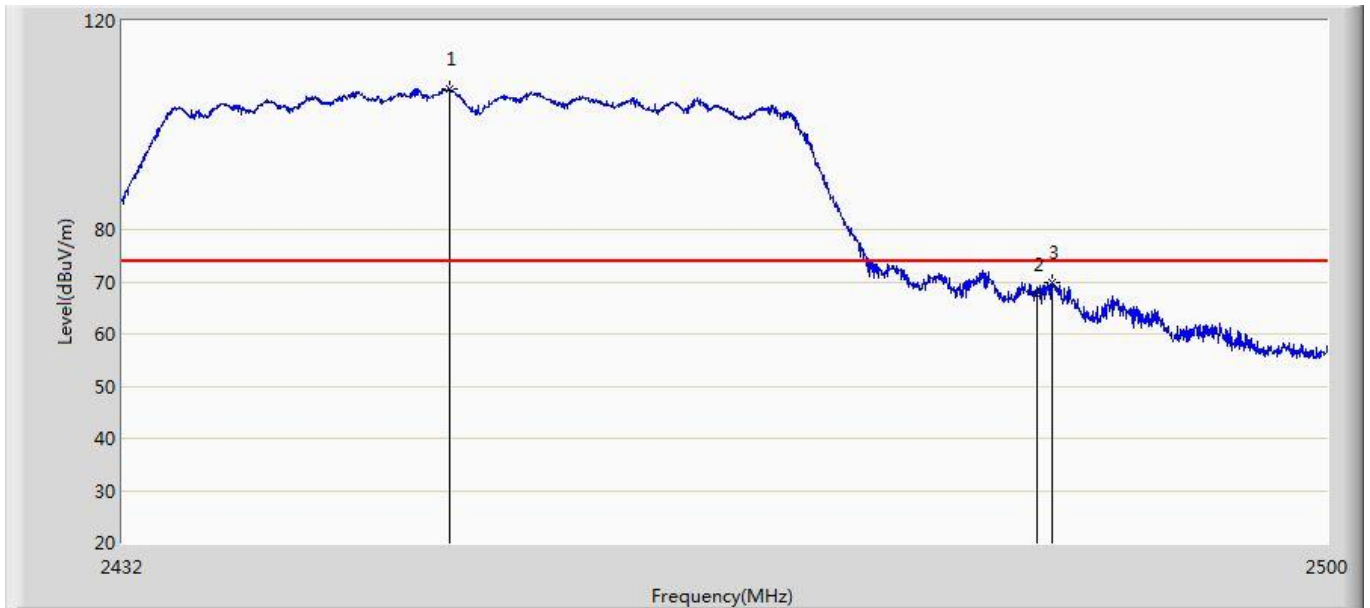

No	Mark	Frequency (MHz)	Measure Level (dBuV/m)	Reading Level (dBuV)	Over Limit (dB)	Limit (dBuV/m)	Factor (dB)	Type
1	*	2450.292	106.867	70.469	32.867	74.000	36.397	PK
2		2483.500	67.501	31.034	-6.499	74.000	36.467	PK
3		2484.360	69.980	33.500	-4.020	74.000	36.479	PK

Site: AC5	Time: 2017/05/18- 19:56
Limit: FCC_Part15.209_RE(3m)	Margin: 0
Probe: Horn_3117_00167055(1-18GHz)	Polarity: Vertical
EUT:300Mbps Wireless N Nano Router	Power: AC 120V/60Hz
Note: Mode 4:Transmit at 2452MHz by 802.11N40	

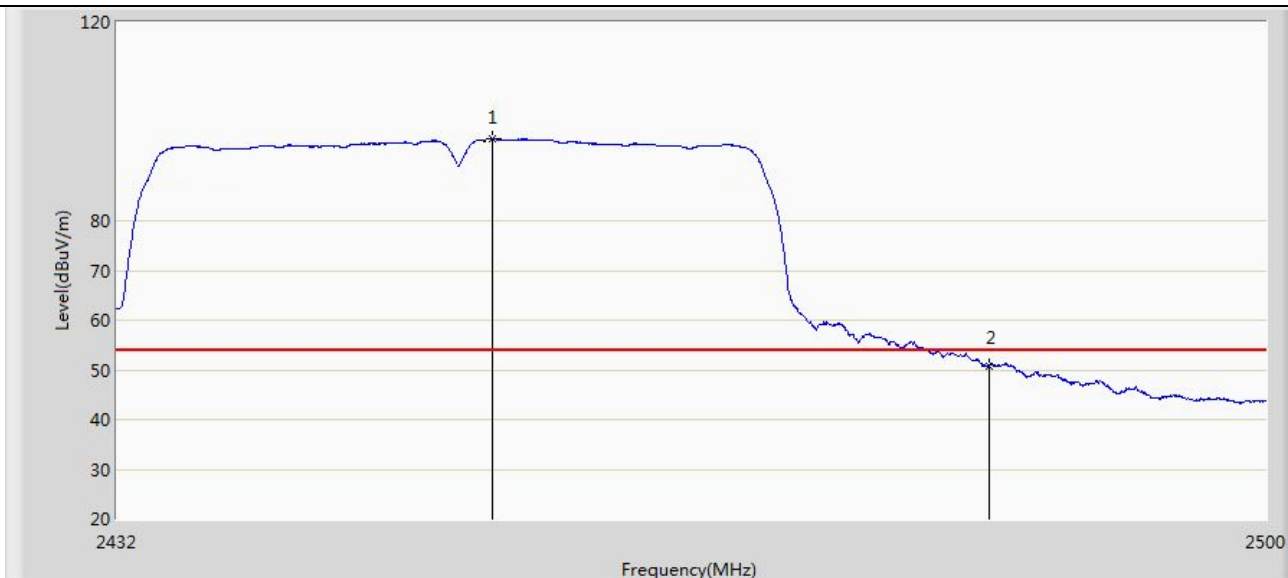

No	Mark	Frequency (MHz)	Measure Level (dBuV/m)	Reading Level (dBuV)	Over Limit (dB)	Limit (dBuV/m)	Factor (dB)	Type
1	*	2454.066	95.342	58.870	41.342	54.000	36.473	AV
2		2483.500	50.856	14.389	-3.144	54.000	36.467	AV

Site: AC5	Time: 2017/05/18- 19:58
Limit: FCC_Part15.209_RE(3m)	Margin: 0
Probe: Horn_3117_00167055(1-18GHz)	Polarity: Vertical
EUT:300Mbps Wireless N Nano Router	Power: AC 120V/60Hz
Note: Mode 4:Transmit at 2452MHz by 802.11N40	

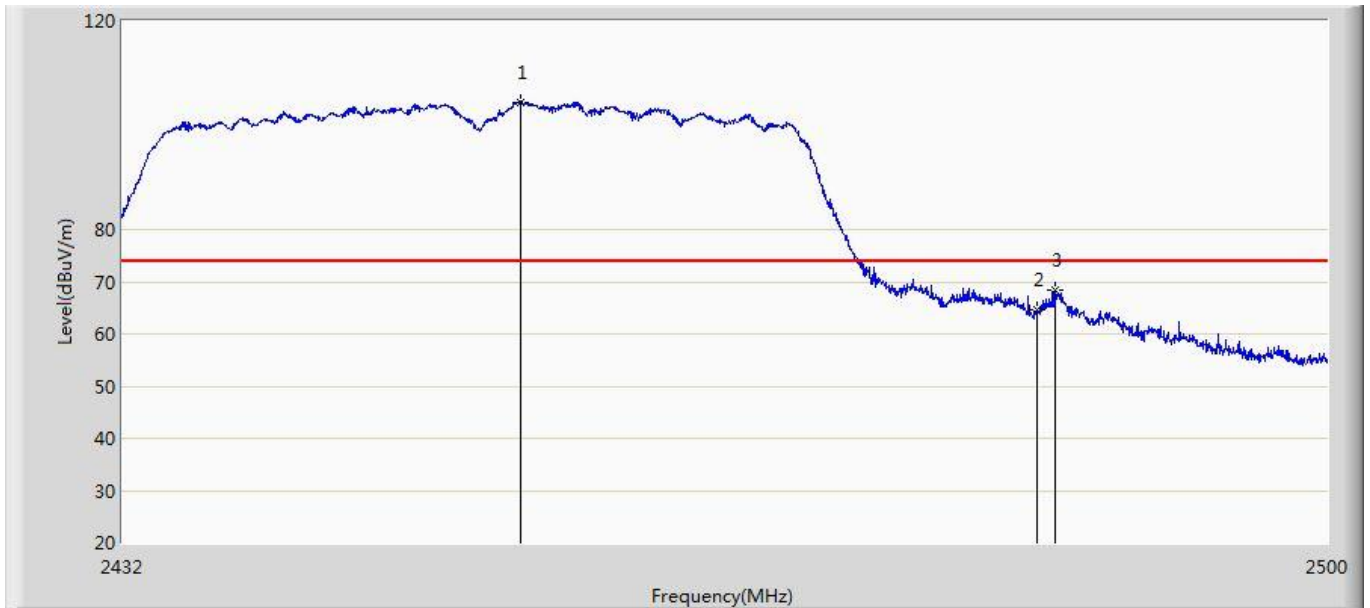

No	Mark	Frequency (MHz)	Measure Level (dBuV/m)	Reading Level (dBuV)	Over Limit (dB)	Limit (dBuV/m)	Factor (dB)	Type
1	*	2454.304	104.442	67.965	30.442	74.000	36.477	PK
2		2483.500	64.553	28.086	-9.447	74.000	36.467	PK
3		2484.530	68.545	32.063	-5.455	74.000	36.483	PK

## 7. Occupied Bandwidth

### 7.1. Test Equipment

Occupied Bandwidth / TR-8					
Instrument	Manufacturer	Type No.	Serial No.	Cal. Date	Cal. Due Date
Spectrum Analyzer	Agilent	N9010A	MY48030494	2017.02.04	2018.02.04
EXA Spectrum Analyzer	Keysight	N9010A	MY55370495	2017.04.09	2018.04.09
MXA Signal Analyzer	Keysight	N9020A	MY56060147	2017.04.09	2018.04.09
Temperature/Humidity Meter	zhichen	ZC1-2	TR8-TH	2017.04.10	2018.04.10

Note: All equipments are calibrated with traceable calibrations. Each calibration is traceable to the national or international standards.

### 7.2. Test Setup

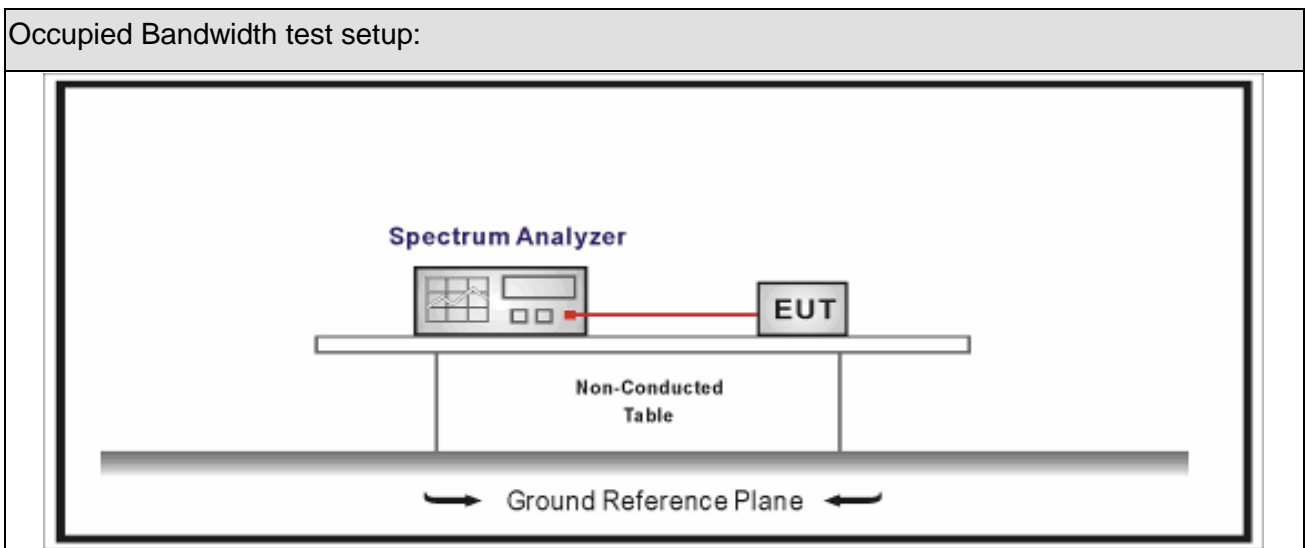



### 7.3. Limit

Occupied Bandwidth
Systems using digital modulation techniques operate in the 2400-2483.5 MHz. The minimum 6 dB bandwidth shall be at least 500 kHz

### 7.4. Test Procedure

Test Method			
	Reference Rule	Chapter	Description
<input checked="" type="checkbox"/>	ANSI C63.10	11.8	DTS bandwidth
	<input type="checkbox"/> ANSI C63.10	11.8.1	Option 1
	<input checked="" type="checkbox"/> ANSI C63.10	11.8.2	Option 2

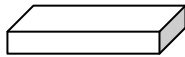
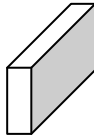
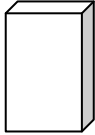
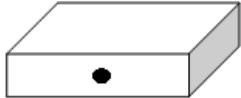
**7.5. EUT test definition**

Item	Occupied Bandwidth			
Device Category	<input checked="" type="checkbox"/>	Fixed position use		
	<input type="checkbox"/>	Mobile position use		
Test mode	Mode 1~4			
Test method	<input type="checkbox"/>	Radiated		
		X Axis	Y Axis	Z Axis
				
		Worst Axis <input type="checkbox"/>	Worst Axis <input type="checkbox"/>	Worst Axis <input type="checkbox"/>
	<input checked="" type="checkbox"/>	Conducted		
	<input checked="" type="checkbox"/>	Chain 1		
				
	<input type="checkbox"/>	Chain 1	Chain 2	
				
	<input type="checkbox"/>	Chain 1	Chain 2	Chain 3
				

## 7.6. Test Result

Product Name	: Cassia Bluetooth Router	Power	: AC 120V / 60Hz
Test Mode	: Mode1~4	Test Site	: TR8
Test Date	: 2017.05.20		

Mode	CH.	Test Freq. (MHz)	99% Occupied Bandwidth (MHz)	6dB Occupied Bandwidth (MHz)	Limit (kHz)	Result
1	01	2412	13.370	9.567	>500	Pass
1	06	2437	13.374	10.03	>500	Pass
1	11	2462	13.325	9.577	>500	Pass
2	01	2412	16.138	15.10	>500	Pass
2	06	2437	16.119	15.11	>500	Pass
2	11	2462	16.128	15.10	>500	Pass
3	01	2412	17.188	15.09	>500	Pass
3	06	2437	17.197	15.09	>500	Pass
3	11	2462	17.154	15.08	>500	Pass
4	03	2422	35.643	33.76	>500	Pass
4	06	2437	35.631	33.85	>500	Pass
4	09	2452	35.592	33.84	>500	Pass

## 8. Fundamental emission output power

### 8.1. Test Equipment

Fundamental emission output power/ TR-8					
Instrument	Manufacturer	Type No.	Serial No.	Cal. Date	Cal. Due Date
Spectrum Analyzer	Agilent	E4446A	MY45300103	2017.01.04	2018.01.04
Spectrum Analyzer	Agilent	N9010A	MY48030494	2017.02.04	2018.02.04
Wideband Peak Power Meter	Anritsu	ML2495A	0905006	2016.10.14	2017.10.14
Power Sensor	Anritsu	MA2411B	0846014	2016.10.14	2017.10.14
Temperature/Humidity Meter	zhicheng	ZC1-2	TR8-TH	2017.04.10	2018.04.10

Note: All equipments are calibrated with traceable calibrations. Each calibration is traceable to the national or international standards.

### 8.2. Test Setup

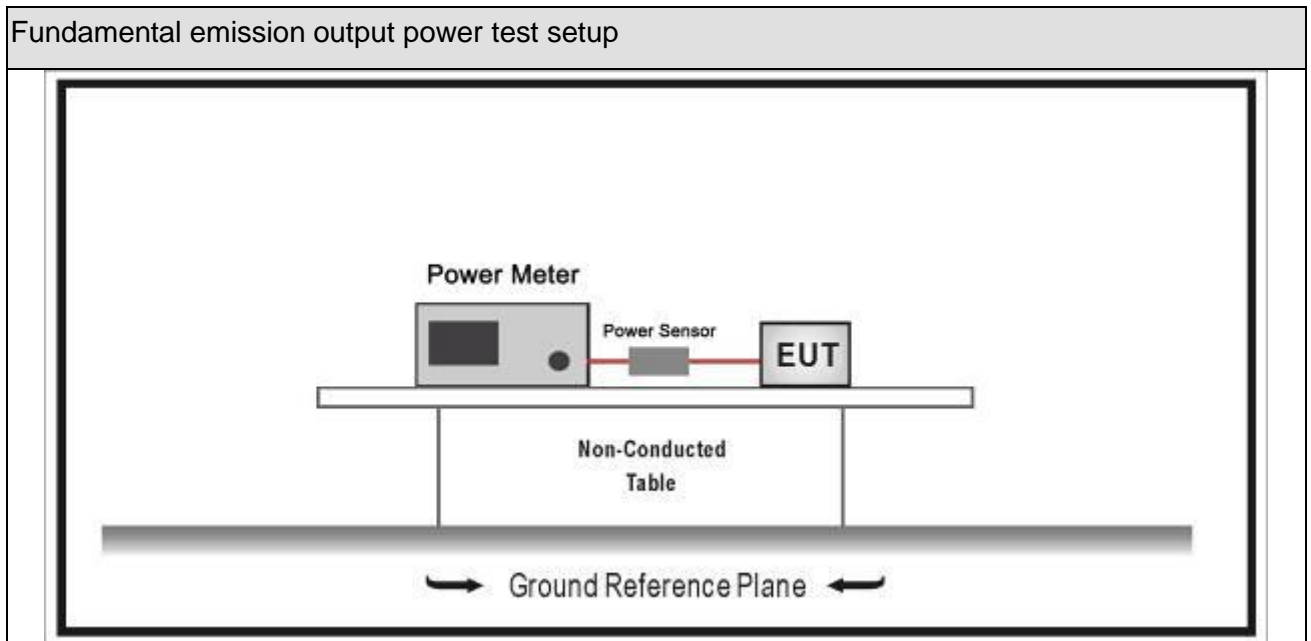





### 8.3. Limit

Fundamental emission output power Limit		
<input checked="" type="checkbox"/>	$G_{TX} < 6\text{dBi}$	$P_{out} \leq 30\text{dBm}$
<input type="checkbox"/>	$G_{TX} > 6\text{dBi}$	
<input type="checkbox"/>	Non-Fix point-point	$P_{out} \leq 30 - (G_{TX} - 6)$
<input checked="" type="checkbox"/>	Fix point-point	$P_{out} \leq 30 - [(G_{TX} - 6)]/3$
<input type="checkbox"/>	emits multiple directional beams but does not do emit multiple directional beams simultaneously	$P_{out} \leq 30 - [(G_{TX} - 6)]/3$
<input type="checkbox"/>	operates simultaneously on multiple directional beams using the same or different frequency channels	$P_{out} \leq 30 - [(G_{TX} - 6)]/3 + 8\text{dB}$
<input type="checkbox"/>	single directional beam	$P_{out} \leq 30 - [(G_{TX} - 6)]/3$
<p>Note 1 : <math>G_{TX}</math> directional gain of transmitting antennas.</p> <p>Note 2 : <math>P_{out}</math> is maximum peak conducted output power .</p>		

### 8.4. Test Procedure

Fundamental emission output power Test Method						
	References Rule		Chapter	Description		
<input checked="" type="checkbox"/>	ANSI C63.10		11.9	Fundamental emission output power		
	<input type="checkbox"/>	ANSI C63.10		11.9.1	Maximum peak conducted output power	
		<input type="checkbox"/>	ANSI C63.10	11.9.1.1	RBW $\geq$ DTS bandwidth	
		<input type="checkbox"/>	ANSI C63.10	11.9.1.2	Integrated band power method	
		<input type="checkbox"/>	ANSI C63.10	11.9.1.3	PKPM1 Peak power meter method	
	<input checked="" type="checkbox"/>	ANSI C63.10		11.9.2	Maximum conducted (average) output power	
		<input type="checkbox"/>	ANSI C63.10		11.9.2.2	Measurement using a spectrum analyzer (SA)
			<input type="checkbox"/>	ANSI C63.10	11.9.2.2.2	Method AVGSA-1(Duty cycle $\geq$ 98%)
			<input type="checkbox"/>	ANSI C63.10	11.9.2.2.3	Method AVGSA-1A(Duty cycle $\geq$ 98%)
			<input type="checkbox"/>	ANSI C63.10	11.9.2.2.4	Method AVGSA-2(Duty cycle $\leq$ 98%)
			<input type="checkbox"/>	ANSI C63.10	11.9.2.2.5	Method AVGSA-2A(Duty cycle $\leq$ 98%)
			<input type="checkbox"/>	ANSI C63.10	11.9.2.2.4	Method AVGSA-3
			<input type="checkbox"/>	ANSI C63.10	11.9.2.2.5	Method AVGSA-3A
		<input checked="" type="checkbox"/>	ANSI C63.10		11.9.2.3	Measurement using a power meter (PM)
		<input type="checkbox"/>	ANSI C63.10	11.9.2.3.1	Method AVGPM	
<input checked="" type="checkbox"/>		ANSI C63.10	11.9.2.3.2	Method AVGPM-G		

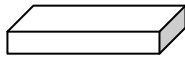
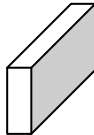
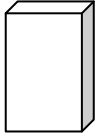
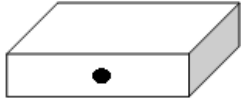
**8.5. EUT test definition**

Item	Fundamental emission output power			
Device Category	<input checked="" type="checkbox"/>	Fixed position use		
	<input type="checkbox"/>	Mobile position use		
Test mode	Mode 1~4			
Test method	<input type="checkbox"/>	Radiated		
		X Axis	Y Axis	Z Axis
				
		Worst Axis <input type="checkbox"/>	Worst Axis <input type="checkbox"/>	Worst Axis <input type="checkbox"/>
	<input checked="" type="checkbox"/>	Conducted		
	<input checked="" type="checkbox"/>	Chain 1		
				
	<input type="checkbox"/>	Chain 1	Chain 2	
				
	<input type="checkbox"/>	Chain 1	Chain 2	Chain 3
				

## 8.6. Test Result

Product Name	: Cassia Bluetooth Router	Power	: AC 120V / 60Hz
Test Mode	: Mode1~4	Test Site	: TR8
Test Date	: 2017.05.20		

Mode	Channel	Test Frequency (MHz)	Average Power Output (dBm)	Limit (dBm)	Result
1	01	2412	16.88	30	Pass
1	03	2422	17.36	30	Pass
1	06	2437	18.62	30	Pass
1	09	2452	17.03	30	Pass
1	11	2462	15.49	30	Pass
2	01	2412	14.53	30	Pass
2	03	2422	16.23	30	Pass
2	06	2437	18.68	30	Pass
2	09	2452	16.97	30	Pass
2	11	2462	13.47	30	Pass
3	01	2412	13.58	30	Pass
3	03	2422	14.79	30	Pass
3	06	2437	18.51	30	Pass
3	09	2452	13.79	30	Pass
3	11	2462	12.52	30	Pass
4	03	2422	8.73	30	Pass

4	04	2427	10.22	30	Pass
4	06	2437	14.52	30	Pass
4	08	2447	10.55	30	Pass
4	09	2452	8.66	30	Pass

Mode	Channel	Test Frequency (MHz)	Average Power Output (dBm)	Antenna Gain (dBi)	E.I.R.P (dBm)	Limit (dBm)	Result
1	01	2412	16.88	3.2	20.08	36	Pass
1	03	2422	17.36	3.2	20.56	36	Pass
1	06	2437	18.62	3.2	21.82	36	Pass
1	09	2452	17.03	3.2	20.23	36	Pass
1	11	2462	15.49	3.2	18.69	36	Pass
2	01	2412	14.53	3.2	17.73	36	Pass
2	03	2422	16.23	3.2	19.43	36	Pass
2	06	2437	18.68	3.2	21.88	36	Pass
2	09	2452	16.97	3.2	20.17	36	Pass
2	11	2462	13.47	3.2	16.67	36	Pass
3	01	2412	13.58	3.2	16.78	36	Pass
3	03	2422	14.79	3.2	17.99	36	Pass
3	06	2437	18.51	3.2	21.71	36	Pass
3	09	2452	13.79	3.2	16.99	36	Pass
3	11	2462	12.52	3.2	15.72	36	Pass

4	03	2422	8.73	3.2	11.93	36	Pass
4	04	2427	10.22	3.2	13.42	36	Pass
4	06	2437	14.52	3.2	17.72	36	Pass
4	08	2447	10.55	3.2	13.75	36	Pass
4	09	2452	8.66	3.2	11.86	36	Pass

Note: E.I.R.P= Average Power Output +Antenna Gain

## 9. Power Spectral Density

### 9.1. Test Equipment

Power Spectral Density / TR-8					
Instrument	Manufacturer	Type No.	Serial No.	Cal. Date	Cal. Due Date
Spectrum Analyzer	Agilent	N9010A	MY48030494	2017.02.04	2018.02.04
EXA Spectrum Analyzer	Keysight	N9010A	MY55370495	2017.04.09	2018.04.09
MXA Signal Analyzer	Keysight	N9020A	MY56060147	2017.04.09	2018.04.09
Temperature/Humidity Meter	zhichen	ZC1-2	TR8-TH	2017.04.10	2018.04.10

Note: All equipments are calibrated with traceable calibrations. Each calibration is traceable to the national or international standards.

### 9.2. Test Setup

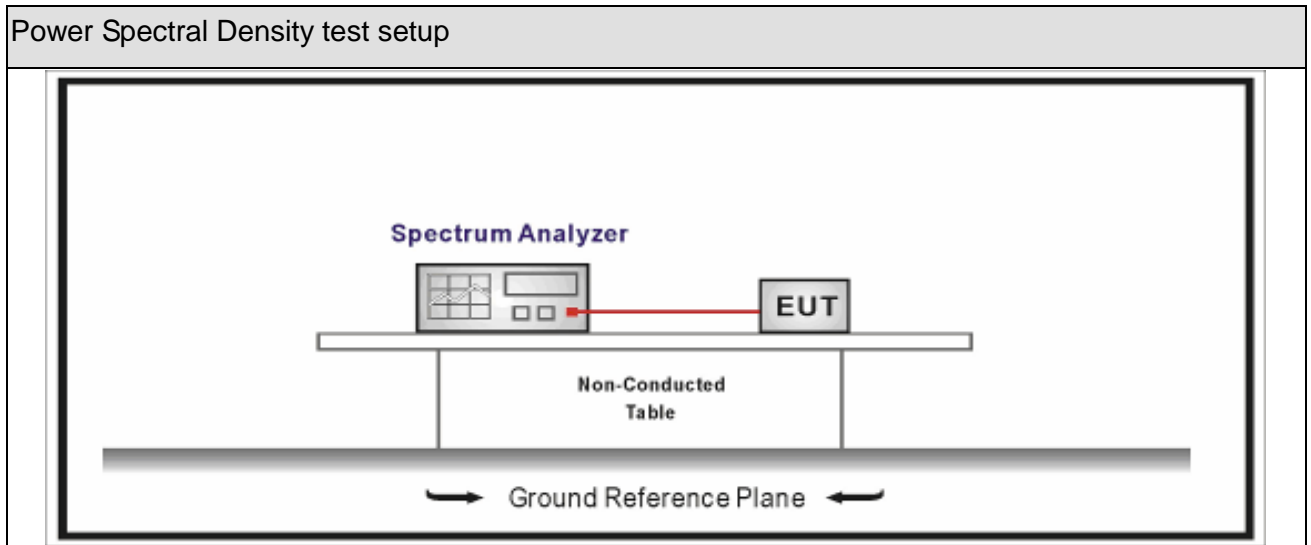

### 9.3. Limit



Power Spectral Density Limit
Power Spectral Density $\leq 8\text{dBm}/3\text{kHz}$

**9.4. Test Procedure**

Power Spectral Density Test Method			
	References Rule	Chapter	Description
<input checked="" type="checkbox"/>	ANSI C63.10	11.10	Maximum power spectral density level in the fundamental emission
<input checked="" type="checkbox"/>	ANSI C63.10	11.10.2	Method PKPSD (peak PSD)
<input type="checkbox"/>	ANSI C63.10	11.10.3	Method AVGPSD-1(Duty cycle $\geq$ 98%)
<input type="checkbox"/>	ANSI C63.10	11.10.4	Method AVGPSD-1A(Duty cycle $\geq$ 98%)
<input type="checkbox"/>	ANSI C63.10	11.10.5	Method AVGPSD-2(Duty cycle $<$ 98%)
<input type="checkbox"/>	ANSI C63.10	11.10.6	Method AVGPSD-2A(Duty cycle $<$ 98%)
<input type="checkbox"/>	ANSI C63.10	11.10.7	Method AVGPSD-3
<input type="checkbox"/>	ANSI C63.10	11.10.8	Method AVGPSD-3A

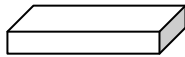
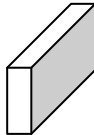
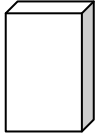
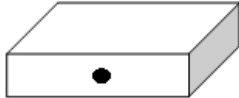

**9.5. EUT test definition**

Item	Power Spectral Density Test Method			
Device Category	<input checked="" type="checkbox"/>	Fixed position use		
	<input type="checkbox"/>	Mobile position use		
Test mode	Mode 1~4			
Test method	<input type="checkbox"/>	Radiated		
		X Axis	Y Axis	Z Axis
				
		Worst Axis <input type="checkbox"/>	Worst Axis <input type="checkbox"/>	Worst Axis <input type="checkbox"/>
	<input checked="" type="checkbox"/>	Conducted		
	<input checked="" type="checkbox"/>	Chain 1		
				
	<input type="checkbox"/>	Chain 1	Chain 2	
				
	<input type="checkbox"/>	Chain 1	Chain 2	Chain 3
				

## 9.6. Test Result

Product Name	: Cassia Bluetooth Router	Power	: AC 120V / 60Hz
Test Mode	: Mode1~4	Test Site	: TR8
Test Date	: 2017.05.20		

Mode	Channel	Test Frequency (MHz)	Measurement PSD (dBm/3kHz)	Limit (dBm/3kHz)	Result
1	01	2412	-5.71	8.0	Pass
1	06	2437	-4.63	8.0	Pass
1	11	2462	-6.27	8.0	Pass
2	01	2412	-7.92	8.0	Pass
2	06	2437	-5.38	8.0	Pass
2	11	2462	-9.07	8.0	Pass
3	01	2412	-8.28	8.0	Pass
3	06	2437	-4.07	8.0	Pass
3	11	2462	-9.65	8.0	Pass
4	03	2422	-15.45	8.0	Pass
4	06	2437	-11.24	8.0	Pass
4	09	2452	-16.37	8.0	Pass

## 10. Antenna Requirement

### 10.1. Limit

Antenna Requirement Limit	
<p>An intentional radiator shall be designed to ensure that no antenna other than that furnished by the responsible party shall be used with the device. The use of a permanently attached antenna or of an antenna that uses a unique coupling to the intentional radiator shall be considered sufficient to comply with the provisions of this section. The manufacturer may design the unit so that a broken antenna can be replaced by the user, but the use of a standard antenna jack or electrical connector is prohibited. This requirement does not apply to carrier current devices or to devices operated under the provisions of §15.211, §15.213, §15.217, §15.219, or §15.221. Further, this requirement does not apply to intentional radiators that must be professionally installed, such as perimeter protection systems and some field disturbance sensors, or to other intentional radiators which, in accordance with §15.31(d), must be measured at the installation site. However, the installer shall be responsible for ensuring that the proper antenna is employed so that the limits in this part are not exceeded.</p>	

### 10.2. Antenna Connector Construction

Antenna Connector Construction	
<input checked="" type="checkbox"/>	The use of a permanently attached antenna
<input type="checkbox"/>	The antenna use of a unique coupling to the intentional radiator
<input type="checkbox"/>	The use of a nonstandard antenna jack or electrical connector
Please refer to the attached document "Internal Photograph" to show the antenna connector.	

\_\_\_\_\_ The End \_\_\_\_\_