



Test Report

FCC Part15 Subpart C & ISED RSS-247 Issue 2

Product Name : Cassia Bluetooth Router
Model No. : S1000、S1000-10、S1000-20、S1000-30、S1100、
S1100-10、S1100-20、S1100-30
FCC ID : 2ALGLS1000
IC : 22505-S1000

Applicant : CASSIA NETWORKS , INC
Address : 1840 Majestic Way, San Jose, CA 95132, USA

Date of Receipt : Mar. 03rd, 2017
Test Date : Mar. 03rd, 2017~ May. 31st, 2017
Issued Date : Jul. 21st, 2017
Report No. : 1732001R-RF- US- P06V01
Report Version : V2.0

The test results relate only to the samples tested.

The test results shown in the test report are traceable to the national/international standard through the calibration of the equipment and evaluated measurement uncertainty herein.

This report must not be used to claim product endorsement by TAF or any agency of the government.

The test report shall not be reproduced without the written approval of DEKRA Testing & Certification (Suzhou) Co., Ltd.

Test Report Certification

Issued Date : Jul. 21st, 2017

Report No. : 1732001R-RF-US-P06V01



Product Name : Cassia Bluetooth Router
 Applicant : CASSIA NETWORKS, INC
 Address : 1840 Majestic Way, San Jose, CA 95132, USA
 Manufacturer : CASSIA NETWORKS, INC
 Address : 1840 Majestic Way, San Jose, CA 95132, USA
 Model No. : S1000、S1000-10、S1000-20、S1000-30、S1100、S1100-10、
 S1100-20、S1100-30
 FCC ID : 2ALGLS1000
 IC : 22505-S1000
 EUT Voltage : S1000、S1000-10、S1000-20、S1000-30: DC 5V/2A
 S1100、S1100-10、S1100-20、S1100-30: DC 5V/2A or
 57Vdc、350mA (PoE)
 Test Voltage : AC 120V/60Hz
 Applicable Standard : FCC CFR Title 47 Part 15 Subpart C: 2015
 ANSI C63.4:2014; ANSI C63.10:2013;
 KDB 558074 D01v04
 ISED RSS-Gen Issue 4 / RSS-247 Issue 2
 Test Result : Complied
 Performed Location : DEKRA Testing & Certification (Suzhou) Co., Ltd.
 No.99 Hongye Rd., Suzhou Industrial Park, Suzhou, 215006,
 Jiangsu, China
 TEL: +86-512-6251-5088 / FAX: +86-512-6251-5098
 FCC Registration Number: 800392; IC Lab Code: 4075B

Documented By : Kitty Li
 (Adm. Specialist: Kitty Li)

Reviewed By : Frank He
 (Senior Engineer: Frank He)

Approved By : Harry Zhao
 (Engineering Manager: Harry Zhao)

TABLE OF CONTENTS

Description	Page
1. General Information.....	6
1.1. EUT Description	6
1.2. Working Frequency of Each Channel:	7
1.3. Antenna information	7
1.4. Mode of Operation.....	8
1.5. Tested System Details	9
1.6. EUT Exercise Software.....	11
2. Technical Test.....	12
2.1. Summary of Test Result.....	12
2.2. Test Frequency configuration:.....	14
2.3. Test Environment.....	15
2.4. Measurement Uncertainty.....	15
3. AC Power Line Conducted Emission.....	16
3.1. Test Equipment.....	16
3.2. Test Setup.....	16
3.3. Limit.....	17
3.4. Test Procedure	17
3.5. Test Result.....	18
4. Emissions in restricted frequency bands	20
4.1. Test Equipment.....	20
4.2. Test Setup.....	21
4.3. Limit.....	22
4.4. Test Procedure	25
4.5. EUT test Axis definition.....	26
4.6. Test Result.....	27
5. Emissions in non-restricted frequency bands	31
5.1. Test Equipment.....	31
5.2. Test Setup.....	31
5.3. Limit.....	32
5.4. Test Procedure	33
5.5. EUT test Axis definition.....	34
5.6. Test Result.....	35
6. Radiated Emission Band Edge	36
6.1. Test Equipment.....	36
6.2. Test Setup.....	37
6.3. Limit.....	37
6.4. Test Procedure	38

- 6.5. EUT test definition 39
- 6.6. Duty Cycle 40
- 6.7 Test Result 41
- 7. Occupied Bandwidth 49
- 7.1. Test Equipment..... 49
- 7.2. Test Setup..... 49
- 7.3. Limit..... 50
- 7.4. Test Procedure 50
- 7.5. EUT test definition 51
- 7.6. Test Result..... 52
- 8. Fundamental emission output power 53
- 8.1. Test Equipment..... 53
- 8.2. Test Setup..... 53
- 8.3. Limit..... 54
- 8.4. Test Procedure 55
- 8.5. EUT test definition 56
- 8.6. Test Result..... 57
- 9. Power Spectral Density 58
- 9.1. Test Equipment..... 58
- 9.2. Test Setup..... 58
- 9.3. Limit..... 58
- 9.4. Test Procedure 59
- 9.5. EUT test definition 60
- 9.6. Test Result..... 61
- 10. Antenna Requirement..... 62
- 10.1. Limit..... 62
- 10.2. Antenna Connector Construction..... 62

History of This Test Report

REPORT NO.	VERSION	DESCRIPTION	ISSUED DATE
1732001R-RF-US-P06V01	V1.0	Initial Issued Report	Jun. 09th, 2017
1732001R-RF-US-P06V01	V2.0	Change the product name	Jul. 21st, 2017

1. General Information

1.1. EUT Description

Product Name	Cassia Bluetooth Router
Model No.	S1000、S1000-10、S1000-20、S1000-30、S1100、S1100-10、S1100-20、S1100-30
EUT Voltage	S1000、S1000-10、S1000-20、S1000-30: DC 5V/2A S1100、S1100-10、S1100-20、S1100-30: DC 5V/2A or 57Vdc、350mA(PoE)
Test Voltage	AC 120V / 60Hz
BT	
Bluetooth Specification	V4.0
Frequency Range	2402- 2480 MHz
Channel Number	V4.0: 40
Channel Separation	V4.0: 2MHz
Type of Modulation	V4.0: GFSK
Data Rate	V4.0: 1Mbps

Note 1: model difference

The PCB of all models are same, only the power supply is difference, S1000 is powered by adapter, S1100 is not only powered by adapter, but also powered by POE.

Note 2: Bluetooth has two antennas, but only antenna 1 can transmit, another one will be closed.

1.2. Working Frequency of Each Channel:

Bluetooth Working Frequency of Each Channel: (For V4.0)							
Channel	Frequency	Channel	Frequency	Channel	Frequency	Channel	Frequency
00	2402 MHz	01	2404 MHz	02	2406 MHz	03	2408 MHz
04	2410 MHz	05	2412 MHz	06	2414 MHz	07	2416 MHz
08	2418 MHz	09	2420 MHz	10	2422 MHz	11	2424 MHz
12	2426 MHz	13	2428 MHz	14	2430 MHz	15	2432 MHz
16	2434 MHz	17	2436 MHz	18	2438 MHz	19	2440 MHz
20	2442 MHz	21	2444 MHz	22	2446 MHz	23	2448 MHz
24	2450 MHz	25	2452 MHz	26	2454 MHz	27	2456 MHz
28	2458 MHz	29	2460 MHz	30	2462 MHz	31	2464 MHz
32	2466 MHz	33	2468 MHz	34	2470 MHz	35	2472 MHz
36	2474 MHz	37	2476 MHz	38	2478 MHz	39	2480 MHz

1.3. Antenna information

Antenna manufacturer	N/A					
Antenna Delivery	<input checked="" type="checkbox"/>	1*TX+1*RX	<input type="checkbox"/>	2*TX+2*RX	<input type="checkbox"/>	3*TX+3*RX
Antenna technology	<input checked="" type="checkbox"/>	SISO				
	<input type="checkbox"/>	MIMO	<input type="checkbox"/>	Basic		
			<input type="checkbox"/>	CDD		
			<input type="checkbox"/>	Beam-forming		
Antenna Type	<input type="checkbox"/>	External	<input type="checkbox"/>	Dipole		
	<input checked="" type="checkbox"/>	Internal	<input type="checkbox"/>	PIFA		
			<input type="checkbox"/>	PCB		
			<input type="checkbox"/>	Ceramic Chip Antenna		
			<input checked="" type="checkbox"/>	Metal plate type F antenna		
Antenna Gain	5dBi					

1.4. Mode of Operation

Pre-Test Mode	
Mode 1: Transmit-1Mbps(GFSK_BLE) with S1000 Powered by adapter	
Mode 2: Transmit-1Mbps(GFSK_BLE) with S1100 Power by adapter	
Mode 3: Transmit-1Mbps(GFSK_BLE) with S1100 Power by adapter POE	
Final Test Mode	
Emission	Mode 1: Transmit-1Mbps(GFSK_BLE) with S1100 Power by adapter

Note : Bluetooth has two antenna port, but only antenna 1 can transmit, another one will be closed.

1.5. Tested System Details

The types for all equipment, plus descriptions of all cables used in the tested system (including inserted cards) are:

Product	Manufacturer	Model No.	Serial No.	Power Cord
1 Notebook	DELL	PP19L	JH097 A01	Power by adapter
2 USB Disk	Corsar	VOYAGER	N/A	N/A
3 Radio Communication Tester	R&S	CMU200	106388	N/A

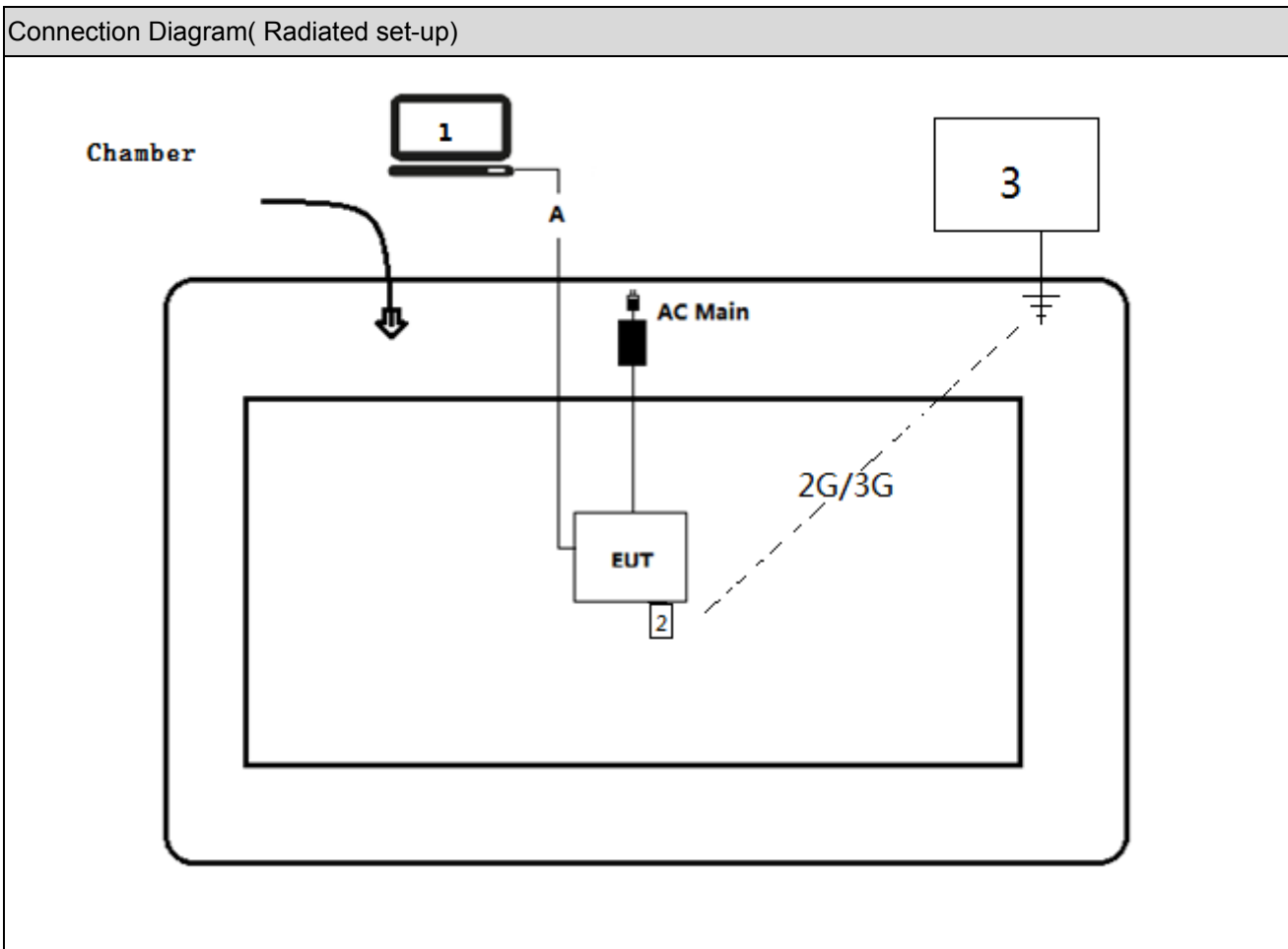

Connection Diagram(Conducted set-up)

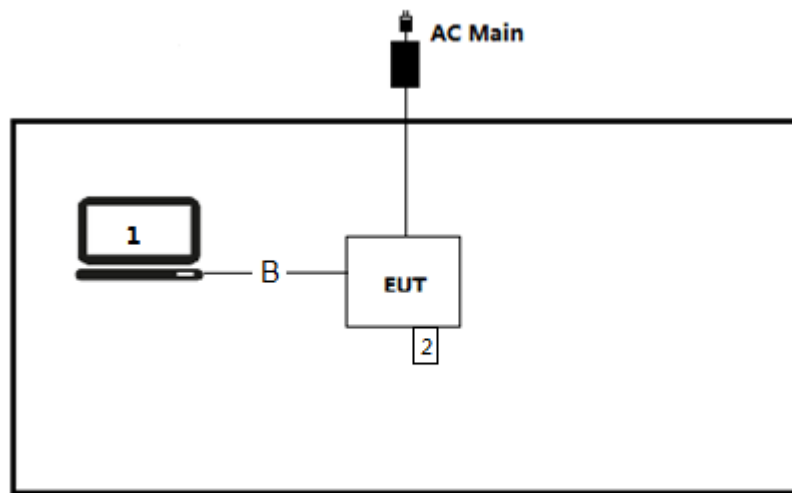

Connection Diagram

A	USB Control Cable	Shielded >15m
B	USB Control Cable	Shielded >1.5m

1.6. EUT Exercise Software

1	Setup the EUT and simulators as shown on above.
2	Turn on the power of all equipment.
3	Run the RF software, and set the test mode and channel, then press OK to start continue receive.

2. Technical Test
2.1. Summary of Test Result

Performed Test Item	Normative References	Worst case mode	Limit	Result
AC Power Line Conducted Emission	FCC CFR Title 47 Part 15 Subpart C: 2015 Section 15.207	Mode 1	FCC 15.207	PASS
Emissions in restricted frequency bands	FCC CFR Title 47 Part 15 Subpart C: 2015 Section 15.209	Mode 1	FCC 15.209	PASS
Emissions in non-restricted frequency bands	FCC CFR Title 47 Part 15 Subpart C: 2015 Section 15.247(d)	Mode 1	≥20dBc	PASS
Radiated Emission Band Edge	FCC CFR Title 47 Part 15 Subpart C: 2015 15.247(d)	Mode 1	FCC 15.209	PASS
Occupied Bandwidth	FCC CFR Title 47 Part 15 Subpart C: 2015 Section 15.247(a)(2)	Mode 1	≥500kHz	PASS
Fundamental emission output power	FCC CFR Title 47 Part 15 Subpart C: 2015 Section 15.247(b)(3)	Mode 1	≤30dBm	PASS
Power Spectral Density	FCC CFR Title 47 Part 15 Subpart C: 2015 Section 15.247(e)	Mode 1	≤8dBm/3kHz	PASS
Antenna Requirement	FCC CFR Title 47 Part 15 Subpart C: 2015 Section 15.203	N/A	FCC 15.203	PASS

Performed Test Item	Normative References	Worst case mode	Limit	Result
AC Power Line Conducted Emission	RSS-Gen Issue 4 Section 8.8	Mode 1	RSS-Gen	PASS
Emissions in restricted frequency bands	RSS-Gen Issue 4 Section 8.9	Mode 1	RSS-Gen	PASS
Emissions in non-restricted frequency bands	RSS-247 Issue 2 Section A5.5	Mode 1	≥20dBc	PASS
Radiated Emission Band Edge	RSS-247 Issue 2 Section A5.5	Mode 1	RSS-247	PASS
Occupied Bandwidth	RSS-Gen Issue 4 Section 6.6 RSS-247 Issue 2 Section A5.2(1)	Mode 1	≥500kHz	PASS
Fundamental emission output power	RSS-247 Issue 2 Section A5.4(4)	Mode 1	≤30dBm	PASS

Power Spectral Density	RSS-247 Issue 2 Section A5.2(2)	Mode 1	$\leq 8\text{dBm}/3\text{kHz}$	PASS
Antenna Requirement	RSS-Gen Issue 4 Section 8.3	N/A	RSS-Gen Issue 4	PASS

2.2. Test Frequency configuration:

Modulation Mode	Channel	Frequency	Channel	Frequency	Channel	Frequency
BLE	00	2402 MHz	19	2440 MHz	39	2480MHz

2.3. Test Environment

Items	Required (IEC 68-1)	Actual
Temperature (°C)	15-35	21
Humidity (%RH)	25-75	50
Barometric pressure (mbar)	860-1060	950-1000

2.4. Measurement Uncertainty

Test Items	Uncertainty
AC Power Line Conducted Emission	$\pm 2.02\text{dB}$
Radiated Emission	Below 1GHz $\pm 3.8\text{ dB}$
	Above 1GHz $\pm 3.9\text{ dB}$
RF Antenna Port Conducted Emission	$\pm 1.27\text{dB}$
Radiated Emission Band Edge	$\pm 3.9\text{dB}$
Occupied Bandwidth	$\pm 1\text{kHz}$
Power Spectral Density	$\pm 1.27\text{dB}$

3. AC Power Line Conducted Emission

3.1. Test Equipment

AC Power Line Conducted Emission / TR-1					
Instrument	Manufacturer	Type No.	Serial No.	Cal. Date	Cal. Due Date
EMI Test Receiver	R&S	ESCI	100906	2017.03.05	2018.03.04
Two-Line V-Network	R&S	ENV 216	101189	2016.07.16	2017.07.15
Two-Line V-Network	R&S	ENV 216	101044	2016.09.16	2017.09.15
50ohm Coaxial Switch	Anritsu	MP59B	6200464462	N/A	N/A
50ohm Termination	SHX	TF2	07081402	2016.09.16	2017.09.15
Temperature/Humidity Meter	Zhichen	ZC1-2	TR1-TH	2017.01.04	2018.01.03

Note: All equipment are calibrated with traceable calibrations. Each calibration is traceable to the national or international standards.

3.2. Test Setup

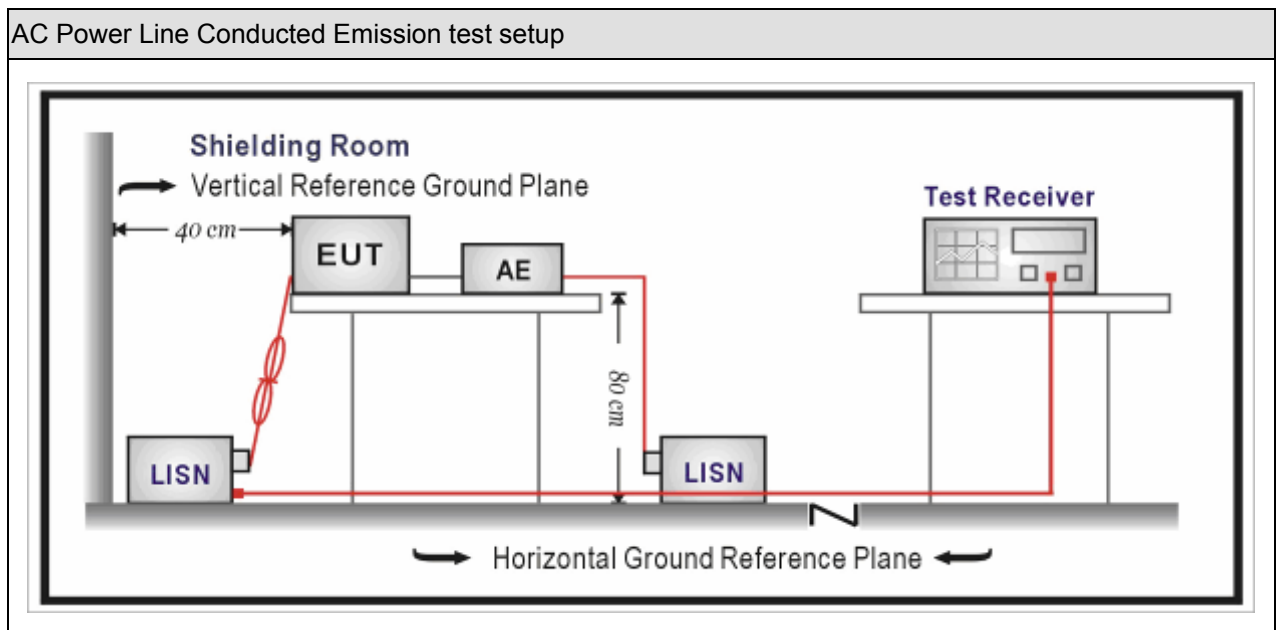

3.3. Limit

Frequency of Emission (MHz)	Conducted Limit	
	Quasi-peak (dB μ V)	Average (dB μ V)
0.15-0.5	66 to 56	56 to 46
0.5-5	56	46
5-30	60	50

Note 1: The lower limit shall apply at the transition frequencies.
 Note 2: The limit decreases linearly with the logarithm of the frequency in the range 0.15 MHz to 0.5 MHz.

3.4. Test Procedure

Test Method			
	References Rule	Chapter	Item
<input checked="" type="checkbox"/>	ANSI C63.10-2013	6.2	Standard test method for ac power-line conducted emissions from unlicensed wireless devices
<input checked="" type="checkbox"/>	ANSI C63.4-2014	7	AC power-line conducted emission measurements

3.5. Test Result

Engineer: Johnson	
Site: TR1	Time: 2017/04/18
Limit: FCC_Part15.107_CE_AC Power_ClassB	Margin: 0
Probe: ENV216_101044(0.009-30MHz)	Polarity: Line
EUT: Cassia Bluetooth Router	Power: AC 120V/60Hz
Note: WiFi + BT	

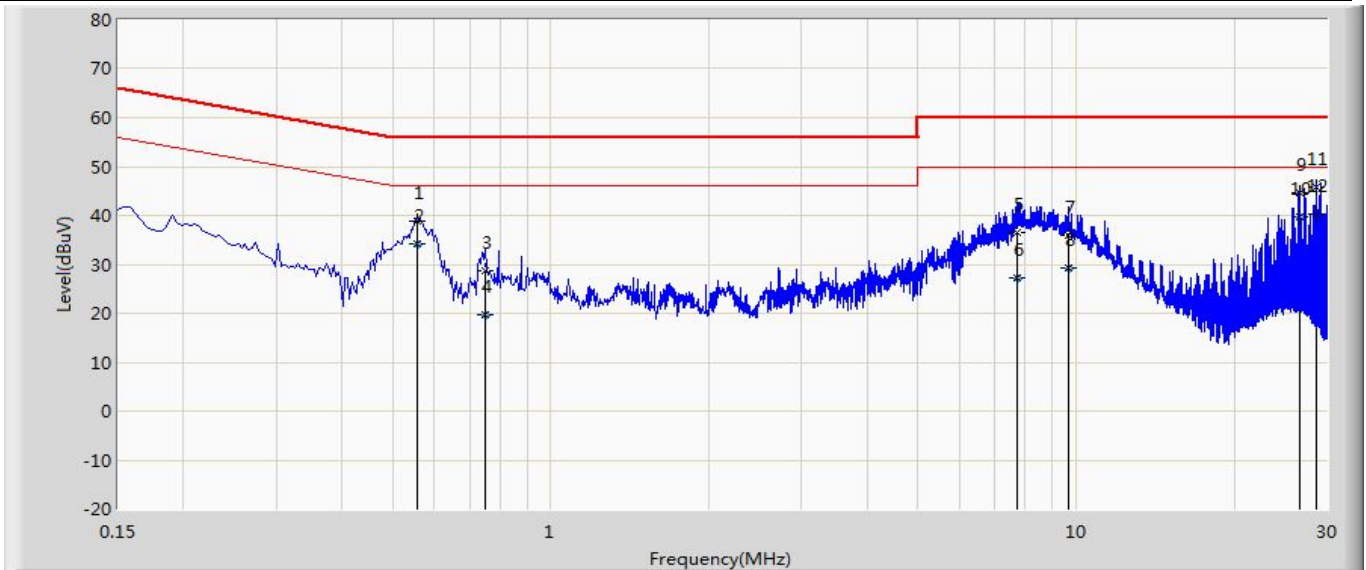

No	Mark	Frequency (MHz)	Measure Level (dBuV)	Reading Level (dBuV)	Over Limit (dB)	Limit (dBuV)	Probe (dB)	Cable (dB)	Amp (dB)	Type
1		0.558	38.782	29.147	-17.218	56.000	9.590	0.045	0.000	QP
2		0.558	34.095	24.461	-11.905	46.000	9.590	0.045	0.000	AV
3		0.750	28.672	19.029	-27.328	56.000	9.592	0.051	0.000	QP
4		0.750	19.845	10.202	-26.155	46.000	9.592	0.051	0.000	AV
5		7.734	36.529	26.712	-23.471	60.000	9.640	0.177	0.000	QP
6		7.734	27.325	17.508	-22.675	50.000	9.640	0.177	0.000	AV
7		9.642	36.038	26.200	-23.962	60.000	9.640	0.198	0.000	QP
8		9.642	29.208	19.370	-20.792	50.000	9.640	0.198	0.000	AV
9		26.610	44.536	34.617	-15.464	60.000	9.584	0.335	0.000	QP
10		26.610	39.611	29.692	-10.389	50.000	9.584	0.335	0.000	AV
11		28.686	45.940	36.022	-14.060	60.000	9.569	0.349	0.000	QP
12	*	28.686	40.158	30.240	-9.842	50.000	9.569	0.349	0.000	AV

Note:

1. " * ", means this data is the worst emission level.
2. Measurement Level = Reading Level + Factor(Probe+Cable-Amp).

Engineer: Johnson	
Site: TR1	Time: 2017/04/18
Limit: FCC_Part15.107_CE_AC Power_ClassB	Margin: 0
Probe: ENV216_101044(0.009-30MHz)	Polarity: Neutral
EUT: Cassia Bluetooth Router	Power: AC 120V/60Hz
Note: WiFi + BT	

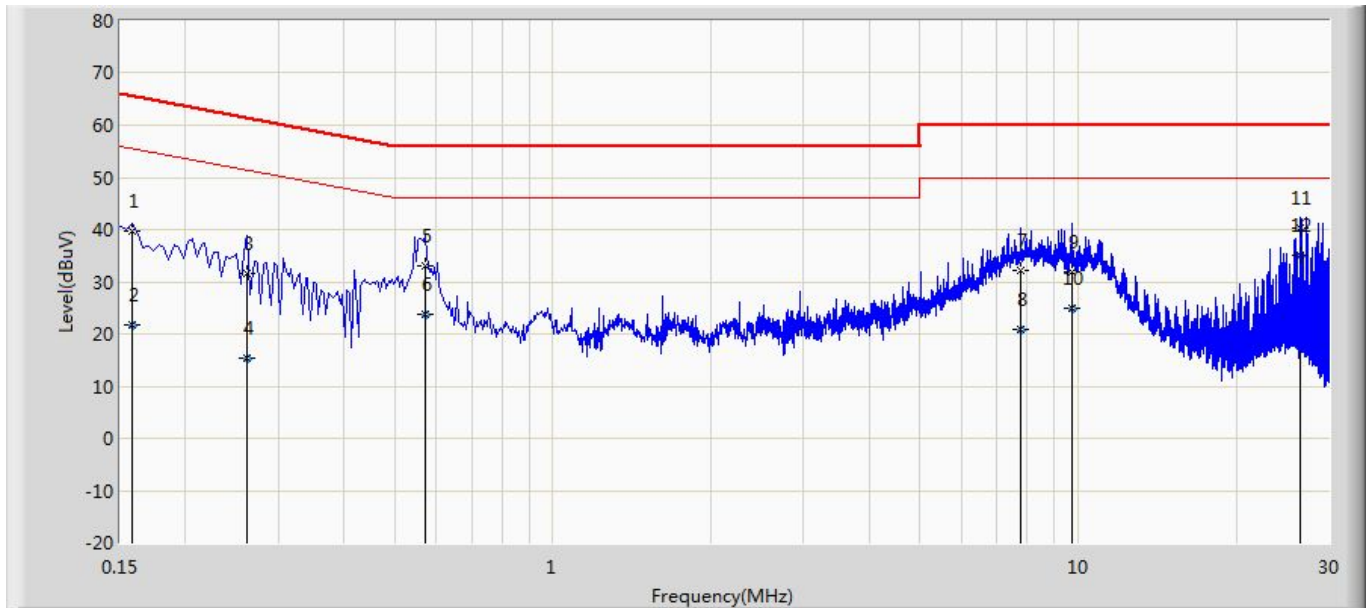

No	Mark	Frequency (MHz)	Measure Level (dBuV)	Reading Level (dBuV)	Over Limit (dB)	Limit (dBuV)	Probe (dB)	Cable (dB)	Amp (dB)	Type
1		0.158	39.694	30.090	-25.874	65.568	9.578	0.026	0.000	QP
2		0.158	21.878	12.274	-33.690	55.568	9.578	0.026	0.000	AV
3		0.262	31.570	21.965	-29.798	61.368	9.572	0.032	0.000	QP
4		0.262	15.402	5.797	-35.966	51.368	9.572	0.032	0.000	AV
5		0.570	32.910	23.274	-23.090	56.000	9.591	0.045	0.000	QP
6		0.570	23.821	14.186	-22.179	46.000	9.591	0.045	0.000	AV
7		7.758	32.153	22.343	-27.847	60.000	9.632	0.178	0.000	QP
8		7.758	20.750	10.940	-29.250	50.000	9.632	0.178	0.000	AV
9		9.706	31.891	22.054	-28.109	60.000	9.639	0.198	0.000	QP
10		9.706	25.039	15.202	-24.961	50.000	9.639	0.198	0.000	AV
11		26.486	40.232	30.254	-19.768	60.000	9.644	0.334	0.000	QP
12	*	26.486	35.105	25.127	-14.895	50.000	9.644	0.334	0.000	AV

Note:

1. " * ", means this data is the worst emission level.
2. Measurement Level = Reading Level + Factor(Probe+Cable-Amp).

4. Emissions in restricted frequency bands

4.1. Test Equipment

Radiated Emission(Below 1GHz) / AC-2					
Instrument	Manufacturer	Type No.	Serial No.	Cal. Date	Cal. Due Date
EMI Test Receiver	R&S	ESCI	100573	2017.03.29	2018.03.28
Loop Antenna	R&S	HFH2-Z2	833799/003	2016.11.16	2017.11.15
Bilog Antenna	Teseq GmbH	CBL6112D	27611	2016.10.16	2017.10.15
Coaxial Cable	Huber+Suhner	SUCOFLEX 106	AC2-C	2016.03.02	2018.03.01
Temperature/Humidity Meter	Zhichen	ZC1-2	AC2-TH	2017.01.03	2018.01.02
Note: All equipment are calibrated with traceable calibrations. Each calibration is traceable to the national or international standards.					

Radiated Emission(Above 1GHz) / AC-5					
Instrument	Manufacturer	Type No.	Serial No.	Cal. Date	Cal. Due Date
Spectrum Analyzer	Agilent	E4446A	MY45300103	2017.01.04	2018.01.03
Preamplifier	Miteq	NSP1800-25	1364185	2017.05.06	2018.05.05
Preamplifier	QuieTek	AP-040G	CHM-0906001	2017.05.06	2018.05.05
DRG Horn	ETS-Lindgren	3117	00123988	2017.01.22	2018.01.21
Broad-Band Horn Antenna	Schwarzbeck	BBHA9170	294	2016.11.25	2017.11.24
Coaxial Cable	Huber+Suhner	SUCOFLEX 106	AC5-C1	2016.03.02	2018.03.01
Coaxial Cable	Huber+Suhner	SUCOFLEX 106	AC5-C2	2016.03.02	2018.03.01
Coaxial Cable	Huber+Suhner	SUCOFLEX 102	AC5-C3	2016.03.02	2018.03.01
EMI Receiver	Agilent	N9038A	MY51210196	2017.06.10	2018.06.09
Temperature/Humidity Meter	Zhichen	ZC1-2	AC5-TH	2017.01.04	2018.01.03
Note: All equipment are calibrated with traceable calibrations. Each calibration is traceable to the national or international standards.					

4.2. Test Setup

Below 30MHz Test Setup:

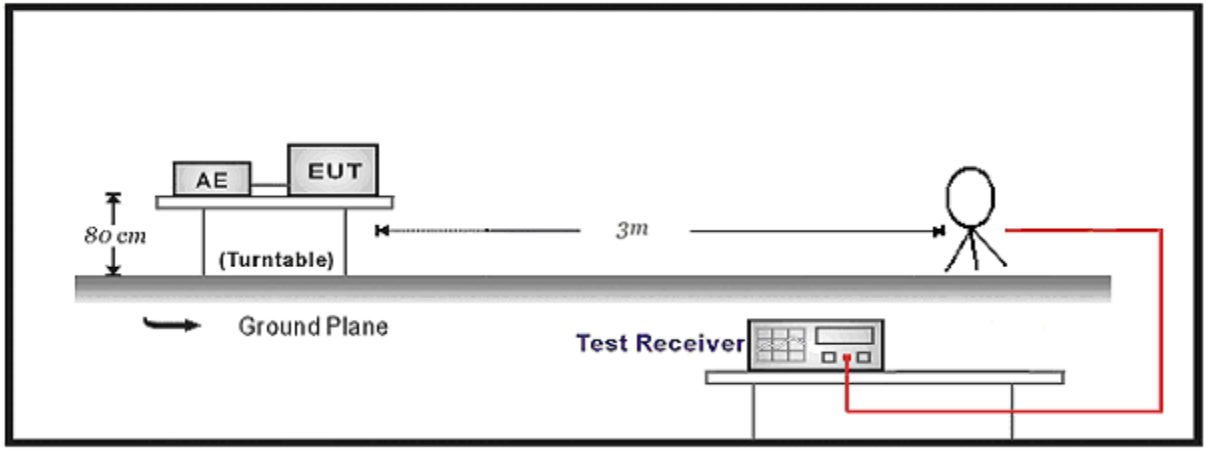

30MHz-1GHz Test Setup:

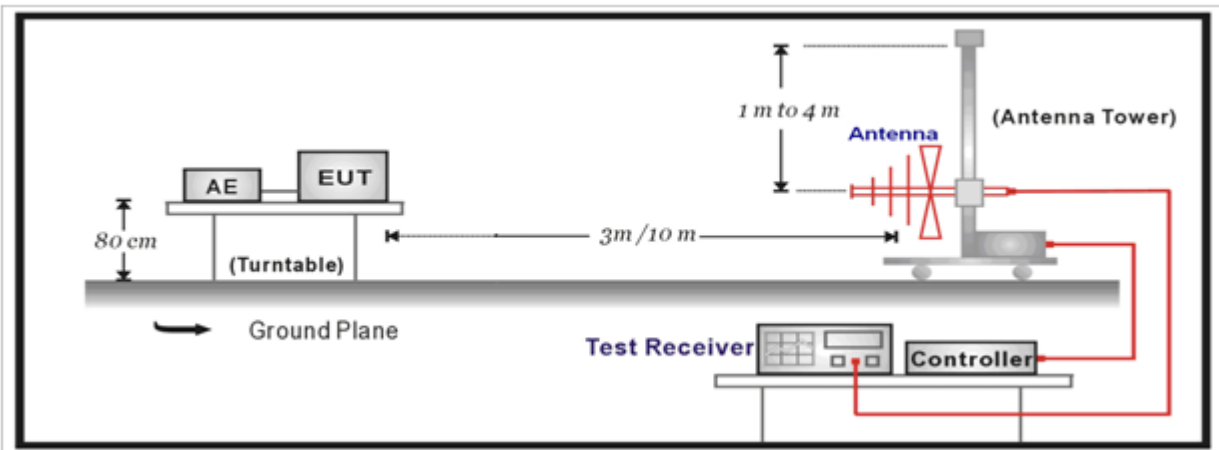

Above 1GHz Test Setup:

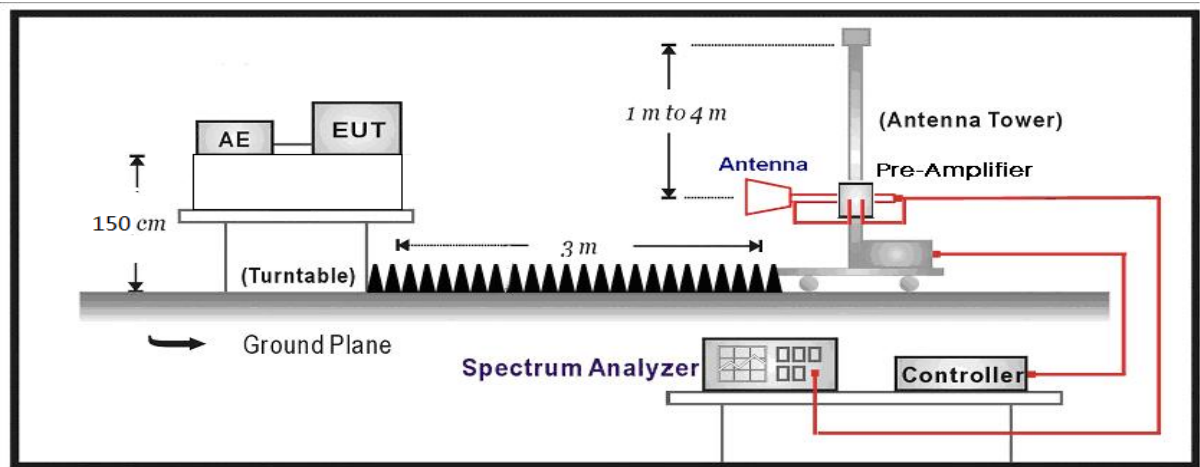

4.3. Limit

For FCC

Restricted Bands of operation			
Frequency (MHz)	Frequency (MHz)	Frequency (MHz)	Frequency (GHz)
0.090 – 0.110	16.42 – 16.423	399.9 – 410	4.5 – 5.15
0.495 – 0.505	16.69475 – 16.69525	608 – 614	5.35 – 5.46
2.1735 – 2.1905	16.80425 – 16.80475	960 – 1240	7.25 – 7.75
4.125 – 4.128	25.5 – 25.67	1300 – 1427	8.025 – 8.5
4.17725 – 4.17775	37.5 – 38.25	1435 – 1626.5	9.0 – 9.2
4.20725 – 4.20775	73 – 74.6	1645.5 – 1646.5	9.3 – 9.5
6.215 – 6.218	74.8 – 75.2	1660 – 1710	10.6 – 12.7
6.26775 – 6.26825	108 – 121.94	1718.8 – 1722.2	13.25 – 13.4
6.31175 – 6.31225	123 – 138	2200 – 2300	14.47 – 14.5
8.291 – 8.294	149.9 – 150.05	2310 – 2390	15.35 – 16.2
8.362 – 8.366	156.52475 – 156.52525	2483.5 – 2500	17.7 – 21.4
8.37625 – 8.38675	156.7 – 156.9	2690 – 2900	22.01 – 23.12
8.81425 – 8.81475	162.0125 – 167.17	3260 – 3267	23.6 – 24.0
12.29 – 12.293	167.72 – 173.2	3332 – 3339	31.2 – 31.8
12.51975 – 12.52025	240 – 285	3345.8 – 3358	36.43 – 36.5
12.57675 – 12.57725	322 – 335.4	3600 – 4400	
13.36 – 13.41			

For ISED:

Restricted Bands of operation			
Frequency (MHz)	Frequency (MHz)	Frequency (MHz)	Frequency (GHz)
0.090-0.110	13.36-13.41	1645.5-1646.5	9.0-9.2
2.1735-2.1905	16.42-16.423	1660-1710	9.3-9.5
3.020-3.026	16.69475-16.69525	1718.8-1722.2	10.6-12.7
4.125-4.128	16.80425-16.80475	2200-2300	13.25-13.4
4.17725-4.17775	25.5-25.67	2310-2390	14.47-14.5
4.20725-4.20775	37.5-38.25	2655-2900	15.35-16.2
5.677-5.683	73-74.6	3260-3267	17.7-21.4
6.215-6.218	74.8-75.2	3332-3339	22.01-23.12
6.26775-6.26825	108-138	3345.8-3358	23.6-24.0
6.31175-6.31225	156.52475-156.52525	3500-4400	31.2-31.8
8.291-8.294	156.7-156.9	4500-5150	36.43-36.5
8.362-8.366	240-285	5350-5460	Above 38.6
8.37625-8.38675	322-335.4	7250-7750	
8.41425-8.41475	399.9-410	8025-8500	
12.29-12.293	608-614		
12.51975-12.52025	960-1427		
12.57675-12.57725	1435-1626.5		

Restricted Band Emissions Limit			
Frequency (MHz)	Field strength (μ V/m)	Field strength (dB μ V/m)	Measurement distance (m)
0.009 - 0.49	2400/F(kHz)	48.5 – 13.8	300 _(Note 1)
0.49 - 1.705	24000/F(kHz)	33.8 - 23	30 _(Note 1)
1.705 - 30	30	29.5	30 _(Note 1)
30 - 88	100	40	3 _(Note 2)
88 - 216	150	43.5	3 _(Note 2)
216 - 960	200	46	3 _(Note 2)
Above 960	500	54	3 _(Note 2)



Note 1: At frequencies below 30 MHz, measurements may be performed at a distance closer than that specified in the regulations; however, an attempt should be made to avoid making measurements in the near field. Pending the development of an appropriate measurement procedure for measurements performed below 30 MHz, when performing measurements at a closer distance than specified, the results shall be extrapolated to the specified distance by either making measurements at a minimum of two distances on at least one radial to determine the proper extrapolation factor or by using the square of an inverse linear distance extrapolation factor (40 dB/decade).

Note 2: At frequencies at or above 30 MHz, measurements may be performed at a distance other than what is specified provided: measurements are not made in the near field except where it can be shown that near field measurements are appropriate due to the characteristics of the device; and it can be demonstrated that the signal levels needed to be measured at the distance employed can be detected by the measurement equipment. Measurements shall not be performed at a distance greater than 30 meters unless it can be further demonstrated that measurements at a distance of 30 meters or less are impractical. When performing measurements at a distance other than that specified, the results shall be extrapolated to the specified distance using an extrapolation factor of 20 dB/decade (inverse linear-distance for field strength measurements; inverse-linear-distance-squared for power density measurements).

4.4. Test Procedure

Test Method			
	References Rule	Chapter	Description
<input type="checkbox"/>	ANSI C63.10	11.11	Emissions in non-restricted frequency bands
	<input type="checkbox"/> ANSI C63.10	11.11.2	Reference level measurement
	<input type="checkbox"/> ANSI C63.10	11.11.3	Emission level measurement
<input checked="" type="checkbox"/>	ANSI C63.10	11.12	Emissions in restricted frequency bands
	<input checked="" type="checkbox"/> ANSI C63.10	11.12.1	Radiated emission measurements
	<input checked="" type="checkbox"/> ANSI C63.10	11.12.2.7	Radiated spurious emission test
	<input checked="" type="checkbox"/> ANSI C63.10	6.4	Radiated emissions from unlicensed wireless devices below 30 MHz
	<input checked="" type="checkbox"/> ANSI C63.10	6.5	Radiated emissions from unlicensed wireless devices in the frequency range of 30 MHz to 1000 MHz
	<input checked="" type="checkbox"/> ANSI C63.10	6.6	Radiated emissions from unlicensed wireless devices above 1 GHz
	<input type="checkbox"/> ANSI C63.10	11.12.2.3	Quasi-peak measurement procedure
	<input type="checkbox"/> ANSI C63.10	11.12.2.4	Peak power measurement procedure
	<input type="checkbox"/> ANSI C63.10	11.12.2.5	Average power measurement procedures
	<input type="checkbox"/> ANSI C63.10	11.12.2.5.1	Trace averaging with continuous EUT transmission at full power
	<input type="checkbox"/> ANSI C63.10	11.12.2.5.2	Trace averaging across ON and OFF times of the EUT transmissions followed by duty cycle correction
	<input type="checkbox"/> ANSI C63.10	11.12.2.5.3	Reduced VBW averaging across ON and OFF times of the EUT transmissions with max hold

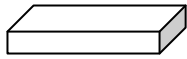
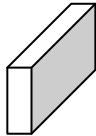
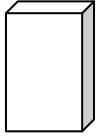
4.5. EUT test Axis definition

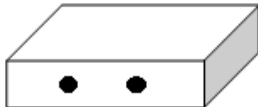
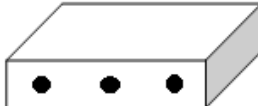
Item	Emissions in restricted frequency bands			
Device Category	<input type="checkbox"/>	Fixed point-to-point		
	<input type="checkbox"/>	Emit multiple directional beams, simultaneously or sequentially		
	<input checked="" type="checkbox"/>	Other cases		
Test mode	Mode 1			
Test method	<input checked="" type="checkbox"/>	Radiated		
		X Axis	Y Axis	Z Axis
				
		Worst Axis <input checked="" type="checkbox"/>	Worst Axis <input type="checkbox"/>	Worst Axis <input type="checkbox"/>
	<input type="checkbox"/>	Conducted		
	<input type="checkbox"/>	Chain 0		
				
	<input type="checkbox"/>	Chain 0	Chain 1	
				
	<input type="checkbox"/>	Chain 0	Chain 1	Chain 2
				

4.6. Test Result

Product Name	: Cassia Bluetooth Router	Power	: AC 120V/60Hz
Test Mode	: Mode 1	Test Site	: AC-5
Test Date	: 2017.05.09		

Chain	CH	Antenna	Frequency (MHz)	Reading Level (dBuV/m)	Factor (dB)	Measure Level (dBuV/m)	Limit (dBuV/m)	Over Limit (dB)	Detector
Ant 0	0	H	4804.000	44.605	6.087	50.692	54(Note3)	-3.308	PK
		H	7206.000	36.694	10.232	46.927	54(Note3)	-7.073	PK
		H	9608.000	34.739	12.559	47.298	54(Note3)	-6.702	PK
		V	4804.000	45.958	6.087	52.045	54(Note3)	-1.955	PK
		V	7206.000	37.696	10.232	47.929	54(Note3)	-6.071	PK
		V	9608.000	34.753	12.559	47.312	54(Note3)	-6.688	PK
	19	H	4880.000	41.497	6.352	47.849	54(Note3)	-6.151	PK
		H	7320.000	35.685	10.320	46.005	54(Note3)	-7.995	PK
		H	9760.000	34.870	12.533	47.403	54(Note3)	-6.597	PK
		V	4880.000	42.792	6.352	49.144	54(Note3)	-4.856	PK
		V	7320.000	35.369	10.320	45.689	54(Note3)	-8.311	PK
		V	9760.000	34.702	12.533	47.235	54(Note3)	-6.765	PK
	39	H	4960.000	39.198	6.408	45.606	54(Note3)	-8.394	PK
		H	7440.000	35.222	10.717	45.940	54(Note3)	-8.060	PK
		H	9920.000	33.716	12.628	46.344	54(Note3)	-7.656	PK
		V	4960.000	40.272	6.408	46.680	54(Note3)	-7.320	PK
		V	7440.000	34.931	10.717	45.648	54(Note3)	-8.352	PK
		V	9920.000	33.564	12.628	46.192	54(Note3)	-7.808	PK

Note: 1. Measure Level = Reading Level + Factor.

Note: 2. The test frequency range, 9kHz~30MHz, 18GHz~25GHz, both of the worst case are at least 20dB below the limits, therefore no data appear in the report.

Note: 3. This limit applies for using average detector, if the test result on peak is lower than average limit, then average measurement needn't be performed.

Note: 4. The RBW set up, see Clause 6.6.

Product Name	: Cassia Bluetooth Router	Power	: AC 120V/60Hz
Test Mode	: Transmit Simultaneously (2G+WIFI+BT)-worst data	Test Site	: AC-5
Test Date	: 2017.05.09		

Transmit at 2462MHz by 802.11n20 and at 2402MHz by BLE.

Antenna	Frequency (MHz)	Reading Level (dBuV/m)	Factor (dB)	Measure Level (dBuV/m)	Limit (dBuV/m)	Over Limit (dB)	Detector
H	4924.000	33.893	8.2	42.093	54(note3)	-11.907	PK
H	7386.000	30.902	12.6	43.502	54(note3)	-10.498	PK
H	9848.000	30.074	16.5	46.574	54(note3)	-7.426	PK
V	4924.000	35.142	8.2	43.342	54(note3)	-10.658	PK
V	7386.000	34.784	12.6	47.384	54(note3)	-6.616	PK
V	9848.000	33.431	16.5	49.931	54(note3)	-4.069	PK
H	4804.000	44.533	6.087	50.620	54(Note3)	-3.38	PK
H	7206.000	36.114	10.232	46.346	54(Note3)	-7.654	PK
H	9608.000	34.457	12.559	47.016	54(Note3)	-6.984	PK
V	4804.000	45.867	6.087	51.954	54(Note3)	-2.046	PK
V	7206.000	37.206	10.232	47.438	54(Note3)	-6.562	PK
V	9608.000	34.732	12.559	47.291	54(Note3)	-6.709	PK

Note: We have evaluated 2G, WiFi, Bluetooth transmit simultaneously, shown in the report is the worst data.

The worst case of Radiated Emission below 1GHz:

Site: AC2	Time: 2017/03/16
Limit: FCC_Part15.109_RE(3m)_ClassB	Margin: 0
Probe: AC2_CBL6112_0726	Polarity: Horizontal
EUT: Cassia Bluetooth Router	Power: AC 120V/60Hz
Note: WiFi + BT	

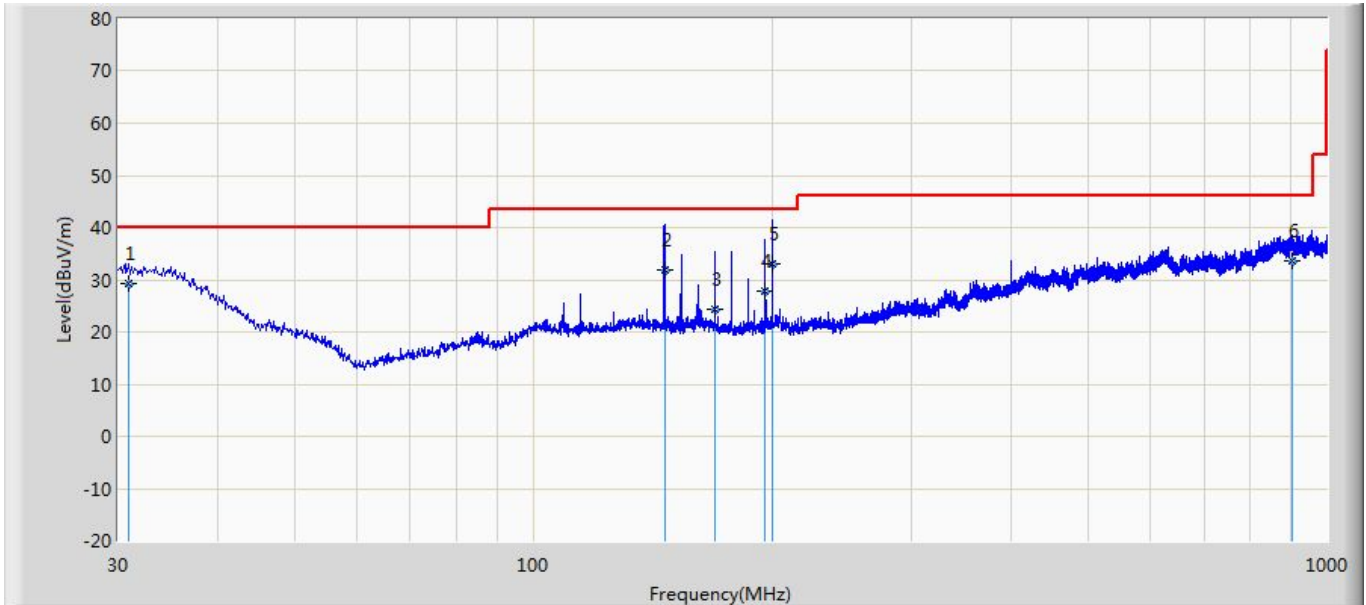

No	Mark	Frequency (MHz)	Measure Level (dBuV/m)	Reading Level (dBuV)	Over Limit (dB)	Limit (dBuV/m)	Probe (dB/m)	Cable (dB)	Amp (dB)	Ant Pos (cm)	Table Pos (deg)	Type
1		30.970	29.347	33.600	-10.653	40.000	18.237	0.610	23.100	100	41	QP
2		146.440	31.804	42.800	-11.696	43.500	10.714	1.310	23.020	200	51	QP
3		169.437	24.360	36.400	-19.140	43.500	9.617	1.410	23.067	100	208	QP
4		196.113	27.941	40.200	-15.559	43.500	9.383	1.520	23.163	300	47	QP
5	*	199.992	33.063	45.214	-10.437	43.500	9.489	1.540	23.180	100	156	QP
6		902.237	33.540	32.500	-12.460	46.000	20.518	3.310	22.788	200	31	QP

Note:

1. " * ", means this data is the worst emission level.
2. Measurement Level = Reading Level + Factor(Probe+Cable-Amp).

Site: AC2	Time: 2017/03/16
Limit: FCC_Part15.109_RE(3m)_ClassB	Margin: 0
Probe: AC2_CBL6112_0726	Polarity: Vertical
EUT: Cassia Bluetooth Router	Power: AC 120V/60Hz
Note: WiFi + BT	

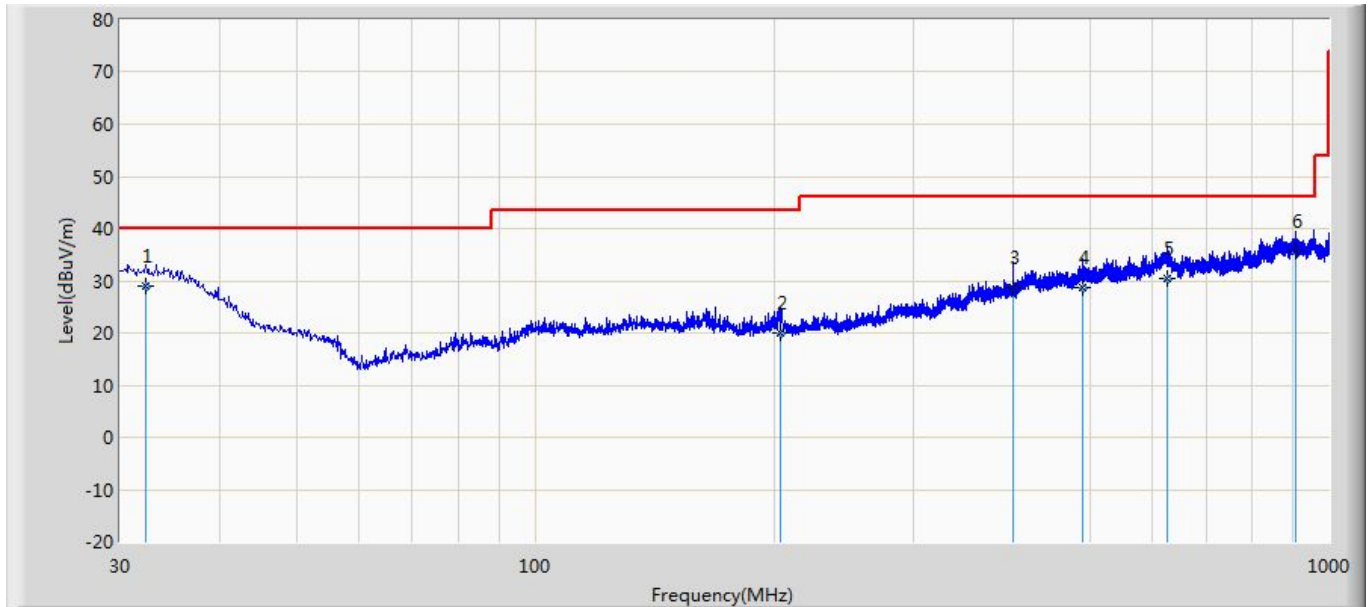

No	Mark	Frequency (MHz)	Measure Level (dBuV/m)	Reading Level (dBuV)	Over Limit (dB)	Limit (dBuV/m)	Probe (dB/m)	Cable (dB)	Amp (dB)	Ant Pos (cm)	Table Pos (deg)	Type
1		32.304	29.064	34.100	-10.936	40.000	17.464	0.624	23.124	100	59	QP
2		203.994	20.140	32.400	-23.360	43.500	9.380	1.550	23.190	200	144	QP
3		400.055	28.785	33.600	-17.215	46.000	16.000	2.215	23.030	100	79	QP
4		490.508	28.588	31.300	-17.412	46.000	17.648	2.400	22.760	100	245	QP
5		624.974	30.404	31.200	-15.596	46.000	19.000	2.740	22.536	200	54	QP
6	*	907.607	35.548	34.400	-10.452	46.000	20.561	3.320	22.733	200	165	QP

Note:

1. " * ", means this data is the worst emission level.
2. Measurement Level = Reading Level + Factor(Probe+Cable-Amp).

5. Emissions in non-restricted frequency bands

5.1. Test Equipment

Emissions in non-restricted frequency bands / TR-8					
Instrument	Manufacturer	Type No.	Serial No.	Cal. Date	Cal. Due Date
Spectrum Analyzer	Agilent	N9010A	MY48030494	2017.02.04	2018.02.03
EXA Spectrum Analyzer	Keysight	N9010A	MY55370495	2017.04.09	2018.04.08
MXA Signal Analyzer	Keysight	N9020A	MY56060147	2017.04.09	2018.04.08
Temperature/Humidity Meter	zhichen	ZC1-2	TR8-TH	2017.04.10	2018.04.09

Note: All equipment are calibrated with traceable calibrations. Each calibration is traceable to the national or international standards.

5.2. Test Setup

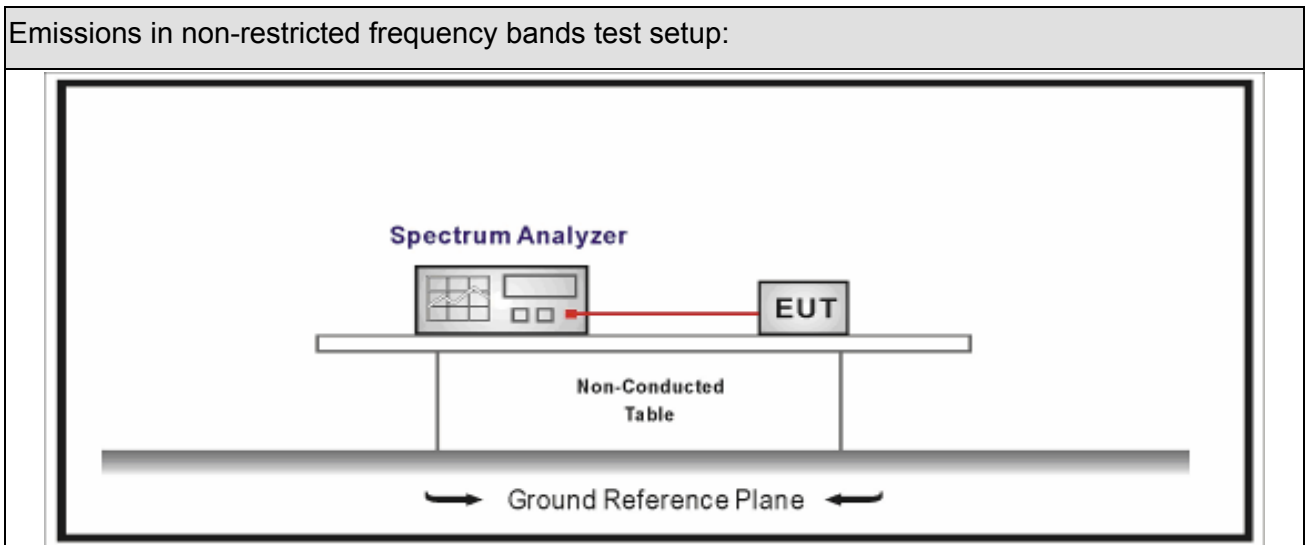





5.3. Limit

Un-Restricted Band Emissions Limit	
RF Output power (Detection methods)	Limit(dB)
RF Output power(Average detector)	30c(Note1)
RF Output power(PK detector)	20c(Note2)
<p>Note 1: If maximum conducted (average) output power was used to demonstrate compliance as described in 9.2, then the peak power in any 100 kHz bandwidth outside of the authorized frequency band shall be attenuated by at least 30 dB relative to the maximum in-band peak PSD level in 100 kHz (i.e., 30 dBc).</p> <p>Note 2: If the maximum peak conducted output power procedure was used, then the peak output power measured in any 100 kHz bandwidth outside of the authorized frequency band shall be attenuated by at least 20 dB relative to the maximum in-band peak PSD level in 100 kHz (i.e., 20 dBc).</p>	

5.4. Test Procedure

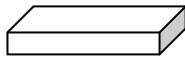
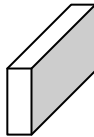
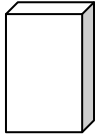
Test Method			
	References Rule	Chapter	Description
<input checked="" type="checkbox"/>	ANSI C63.10	11.11	Emissions in non-restricted frequency bands
	<input checked="" type="checkbox"/> ANSI C63.10	11.11.2	Reference level measurement
	<input checked="" type="checkbox"/> ANSI C63.10	11.11.3	Emission level measurement
<input type="checkbox"/>	ANSI C63.10	11.12	Emissions in restricted frequency bands
	<input type="checkbox"/> ANSI C63.10	11.12.1	Radiated emission measurements
	<input type="checkbox"/> ANSI C63.10	11.12.2.7	Radiated spurious emission test
<input type="checkbox"/>	ANSI C63.10	6.4	Radiated emissions from unlicensed wireless devices below 30 MHz
<input type="checkbox"/>	ANSI C63.10	6.5	Radiated emissions from unlicensed wireless devices in the frequency range of 30 MHz to 1000 MHz
<input type="checkbox"/>	ANSI C63.10	6.6	Radiated emissions from unlicensed wireless devices above 1 GHz
	<input checked="" type="checkbox"/> ANSI C63.10	11.12.2	Antenna-port conducted measurements
	<input type="checkbox"/> ANSI C63.10	11.12.2.3	Quasi-peak measurement procedure
	<input checked="" type="checkbox"/> ANSI C63.10	11.12.2.4	Peak power measurement procedure
	<input type="checkbox"/> ANSI C63.10	11.12.2.5	Average power measurement procedures
	<input type="checkbox"/> ANSI C63.10	11.12.2.5.1	Trace averaging with continuous EUT transmission at full power
	<input type="checkbox"/> ANSI C63.10	11.12.2.5.2	Trace averaging across ON and OFF times of the EUT transmissions followed by duty cycle correction
	<input type="checkbox"/> ANSI C63.10	11.12.2.5.3	Reduced VBW averaging across ON and OFF times of the EUT transmissions with max hold

5.5. EUT test Axis definition

Item	Emissions in non-restricted frequency bands			
Device Category	<input type="checkbox"/>	Fixed point-to-point		
	<input type="checkbox"/>	Emit multiple directional beams, simultaneously or sequentially		
	<input checked="" type="checkbox"/>	Other cases		
Test mode	Mode 1			
Test method	<input type="checkbox"/>	Radiated		
		X Axis	Y Axis	Z Axis
				
		Worst Axis <input type="checkbox"/>	Worst Axis <input type="checkbox"/>	Worst Axis <input type="checkbox"/>
	<input checked="" type="checkbox"/>	Conducted		
	<input checked="" type="checkbox"/>	Chain 0		
				
	<input type="checkbox"/>	Chain 0	Chain 1	
				
	<input type="checkbox"/>	Chain 0	Chain 1	Chain 2
				

5.6. Test Result

Product Name	: Cassia Bluetooth Router	Power	: AC 120V/60Hz
Test Mode	: Mode 1	Test Site	: TR-8
Test Date	: 2017.03.25		

Mode	Channel	Test Frequency (MHz)	In-Band PSD[a] (dBm/100kHz)	Frequency (MHz)	Out-Band PSD[b] (dBm/100kHz)	[a]-[b] (dB)	Limit (dB)	Result
1	00	2402	7.991	2400.00	-49.476	57.467	>20	Pass
1	39	2480	8.397	2500.00	-64.717	73.114	>20	Pass

Note: The worst case of Emissions in non-restricted frequency bands as below:

Mode 1 CH00 (2402MHz)

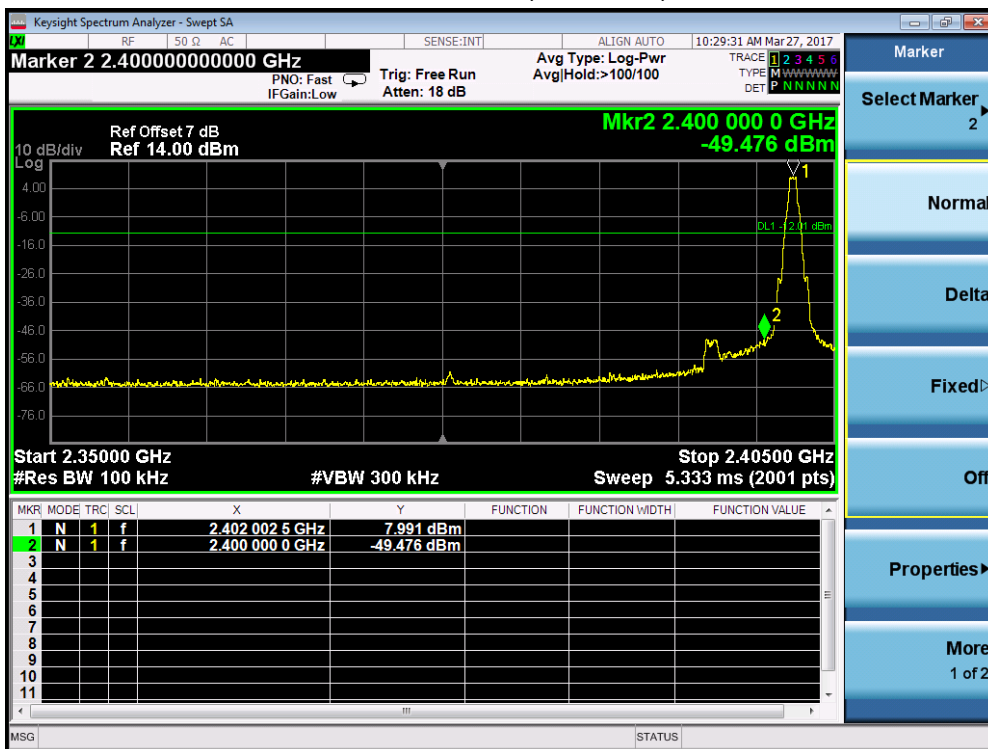

6. Radiated Emission Band Edge

6.1. Test Equipment

Radiated Emission(Above 1GHz) / AC-5					
Instrument	Manufacturer	Type No.	Serial No.	Cal. Date	Cal. Due Date
EMI Receiver	Agilent	N9038A	MY51210196	2016.07.16	2017.07.15
Pre-Amplifier	Miteq	NSP1800-25	1364185	2017.05.03	2018.05.02
DRG Horn Antenna	ETS-Lindgren	3117	00167055	2016.07.12	2017.07.11
Broad-Band Horn Antenna	Schwarzbeck	BBHA9170	294	2016.09.18	2017.09.17
Coaxial Cable	Huber+Suhner	SUCOFLEX 106	AC5-C1	2017.02.28	2018.02.27
Coaxial Cable	Huber+Suhner	SUCOFLEX 106	AC5-C2	2017.02.28	2018.02.27
Temperature/Humidity Meter	Zhichen	ZC1-2	AC5-TH	2017.01.05	2018.01.04

6.2. Test Setup

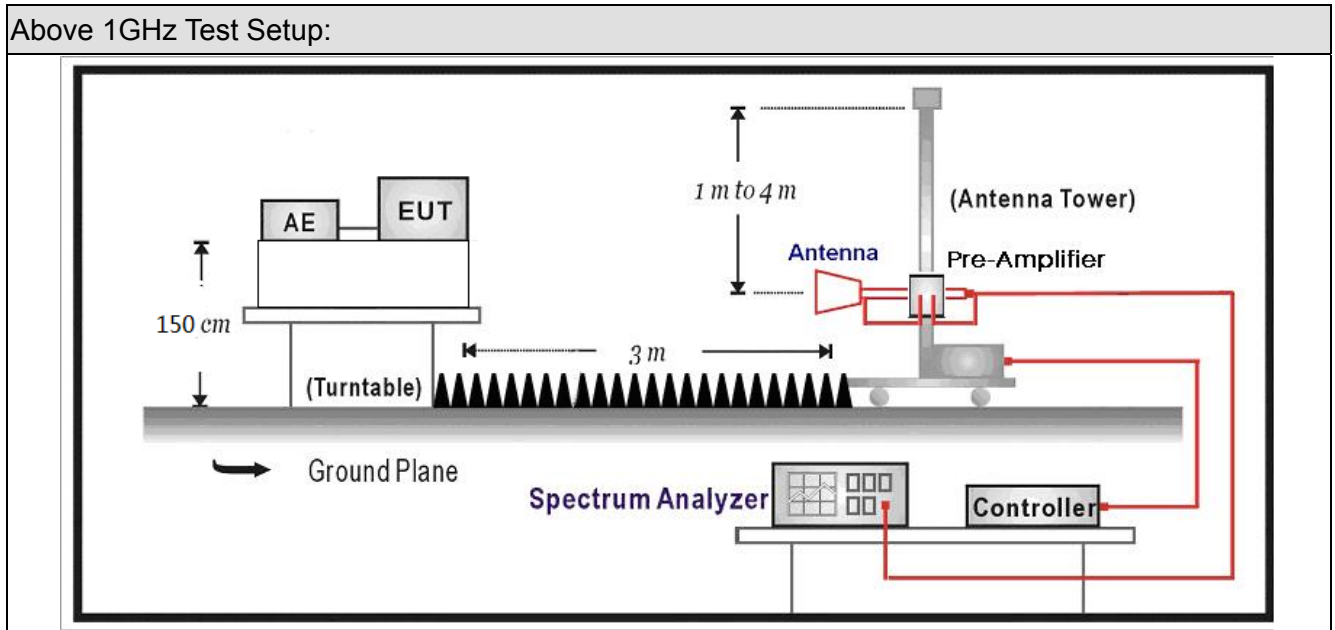

6.3. Limit





Band edge Limit				
Frequency bands (MHz)	Detector	Limit (dB μ V/m)	RBW (MHz)	Distance (m)
2310-2390	PK	74	1	3
2483.5-2500	AV	54	1	3

Note: The field strength of emissions appearing within these frequency bands shall not exceed the limits.

6.4. Test Procedure

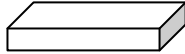
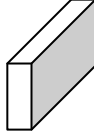
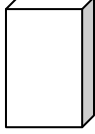
Test Method			
	References Rule	Chapter	Description
<input checked="" type="checkbox"/>	ANSI C63.10	6.10	Band-edge testing
	<input checked="" type="checkbox"/> ANSI C63.10	6.10.5	Restricted-band band-edge measurements
	<input type="checkbox"/> ANSI C63.10	6.10.6	Marker-delta method
<input checked="" type="checkbox"/>	ANSI C63.10	11.12	Emissions in restricted frequency bands
	<input checked="" type="checkbox"/> ANSI C63.10	11.12.1	Radiated emission measurements
	<input checked="" type="checkbox"/> ANSI C63.10	11.12.2.7	Radiated spurious emission test
<input type="checkbox"/>	ANSI C63.10	6.4	Radiated emissions from unlicensed wireless devices below 30 MHz
<input type="checkbox"/>	ANSI C63.10	6.5	Radiated emissions from unlicensed wireless devices in the frequency range of 30 MHz to 1000 MHz
<input checked="" type="checkbox"/>	ANSI C63.10	6.6	Radiated emissions from unlicensed wireless devices above 1 GHz
	<input type="checkbox"/> ANSI C63.10	11.12.2.3	Quasi-peak measurement procedure
	<input checked="" type="checkbox"/> ANSI C63.10	11.12.2.4	Peak power measurement procedure
	<input checked="" type="checkbox"/> ANSI C63.10	11.12.2.5	Average power measurement procedures
	<input type="checkbox"/> ANSI C63.10	11.12.2.5.1	Trace averaging with continuous EUT transmission at full power
	<input type="checkbox"/> ANSI C63.10	11.12.2.5.2	Trace averaging across ON and OFF times of the EUT transmissions followed by duty cycle correction
	<input checked="" type="checkbox"/> ANSI C63.10	11.12.2.5.3	Reduced VBW averaging across ON and OFF times of the EUT transmissions with max hold

6.5. EUT test definition

Item	Radiated Emission Band Edge			
Device Category	<input type="checkbox"/>	Fixed point-to-point		
	<input type="checkbox"/>	Emit multiple directional beams, simultaneously or sequentially		
	<input checked="" type="checkbox"/>	Other cases		
Test mode	Mode 1			
Test method	<input checked="" type="checkbox"/>	Radiated		
		X Axis	Y Axis	Z Axis
				
		Worst Axis <input checked="" type="checkbox"/>	Worst Axis <input type="checkbox"/>	Worst Axis <input type="checkbox"/>
	<input type="checkbox"/>	Conducted		
	<input type="checkbox"/>	Chain 0		
				
	<input type="checkbox"/>	Chain 0	Chain 1	
				
	<input type="checkbox"/>	Chain 0	Chain 1	Chain 2
				

6.6. Duty Cycle

Test Mode	Tx On (ms)	Tx Off (ms)	Reduced VBW (kHz)	Tx On + Tx Off (ms)	Duty Cycle
BLE	0.432	0.816	2.4KHz	1.248	34.62%

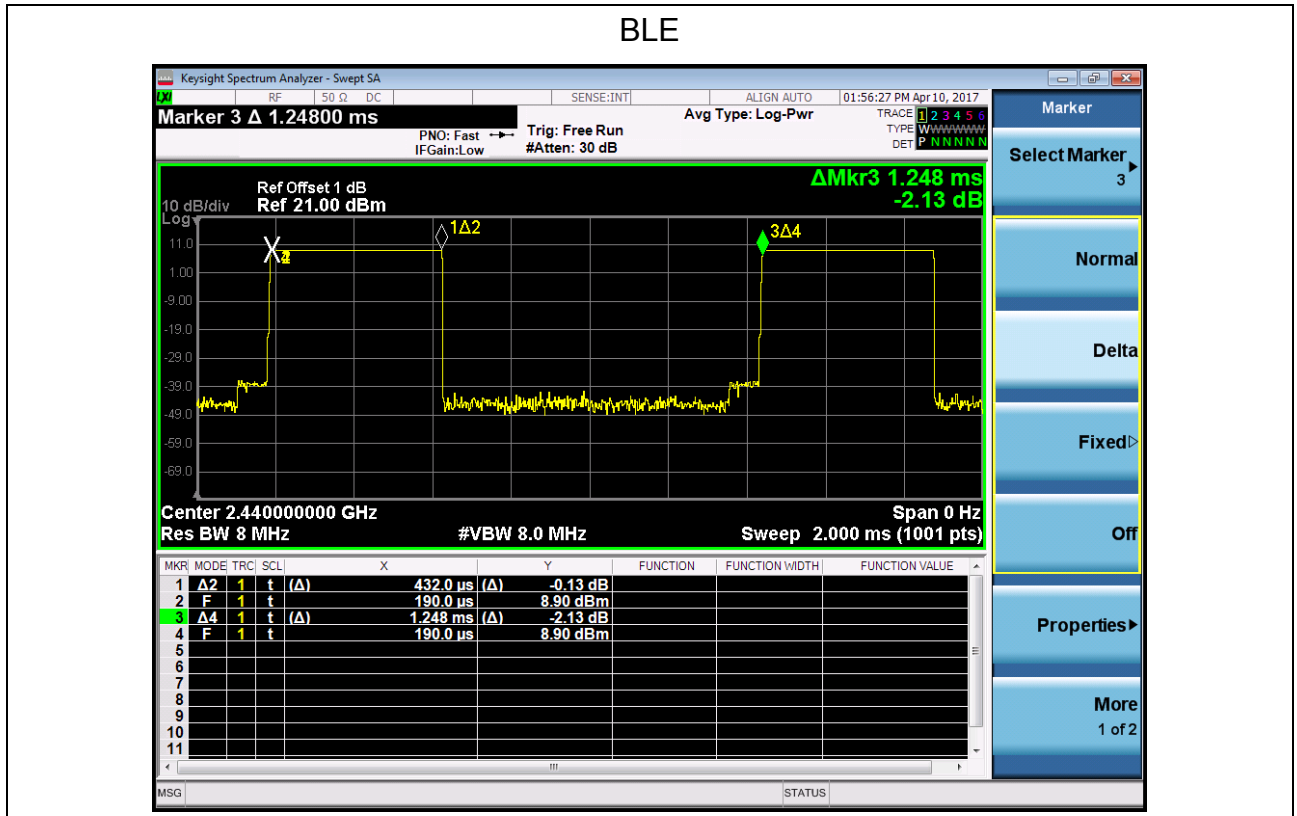

6.7 Test Result

Site: AC5	Time: 2017/03/23 - 11:17
Limit: FCC_Part15.209_RE(3m)	Margin: 0
Probe: Horn_3117_00167055(1-18GHz)	Polarity: Horizontal
EUT: Cassia Bluetooth Router	Power: 120V/60Hz
Note: Mode 1:Transmit at 2402MHz by BLE	

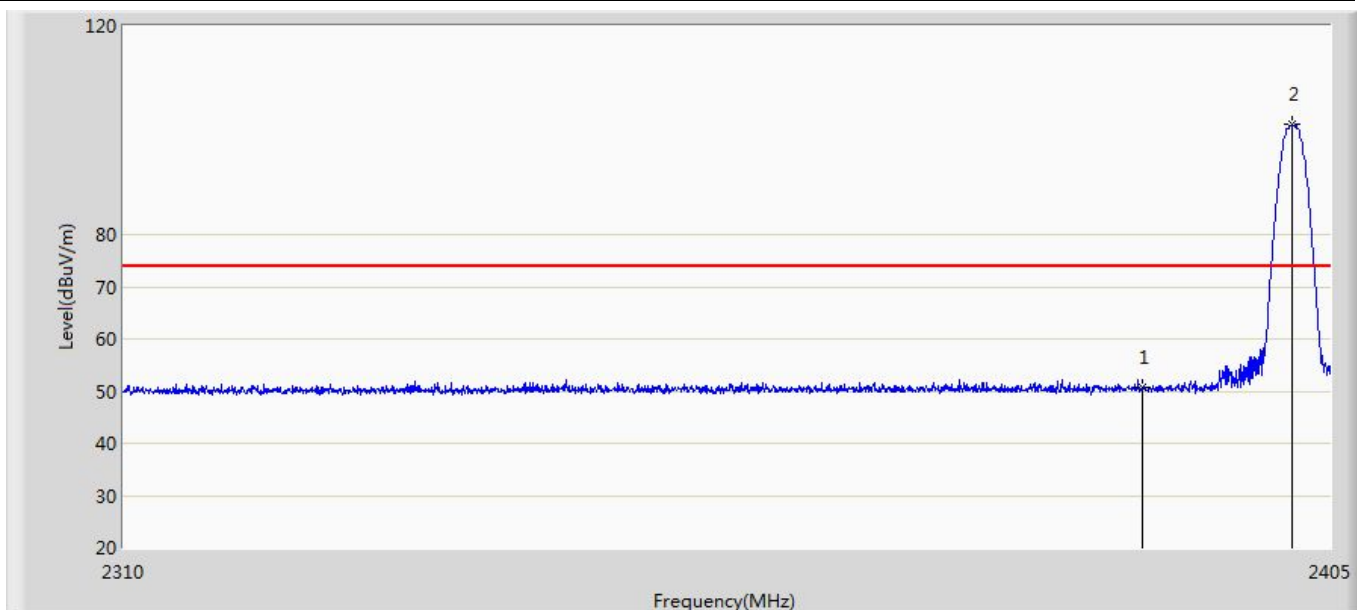

No	Mark	Frequency (MHz)	Measure Level (dBuV/m)	Reading Level (dBuV)	Over Limit (dB)	Limit (dBuV/m)	Factor (dB)	Type
1		2390.000	50.816	15.134	-23.184	74.000	35.682	PK
2	*	2401.960	101.077	65.364	27.077	74.000	35.712	PK

Site: AC5	Time: 2017/03/23 - 11:19
Limit: FCC_Part15.209_RE(3m)	Margin: 0
Probe: Horn_3117_00167055(1-18GHz)	Polarity: Horizontal
EUT: Cassia Bluetooth Router	Power: 120V/60Hz
Note: Mode 1:Transmit at 2402MHz by BLE	

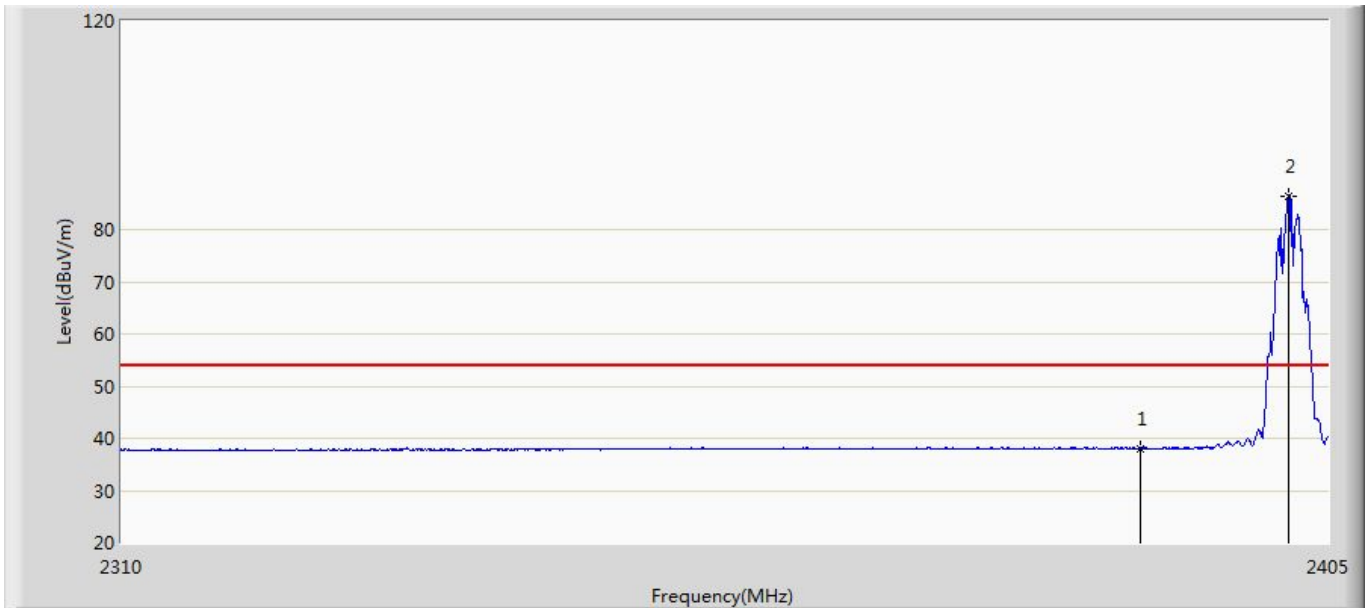

No	Mark	Frequency (MHz)	Measure Level (dBuV/m)	Reading Level (dBuV)	Over Limit (dB)	Limit (dBuV/m)	Factor (dB)	Type
1		2390.000	38.053	2.371	-15.947	54.000	35.682	AV
2	*	2401.817	86.468	50.756	32.468	54.000	35.712	AV

Site: AC5	Time: 2017/03/23 - 11:21
Limit: FCC_Part15.209_RE(3m)	Margin: 0
Probe: Horn_3117_00167055(1-18GHz)	Polarity: Vertical
EUT: Cassia Bluetooth Router	Power: 120V/60Hz
Note: Mode 1:Transmit at 2402MHz by BLE	

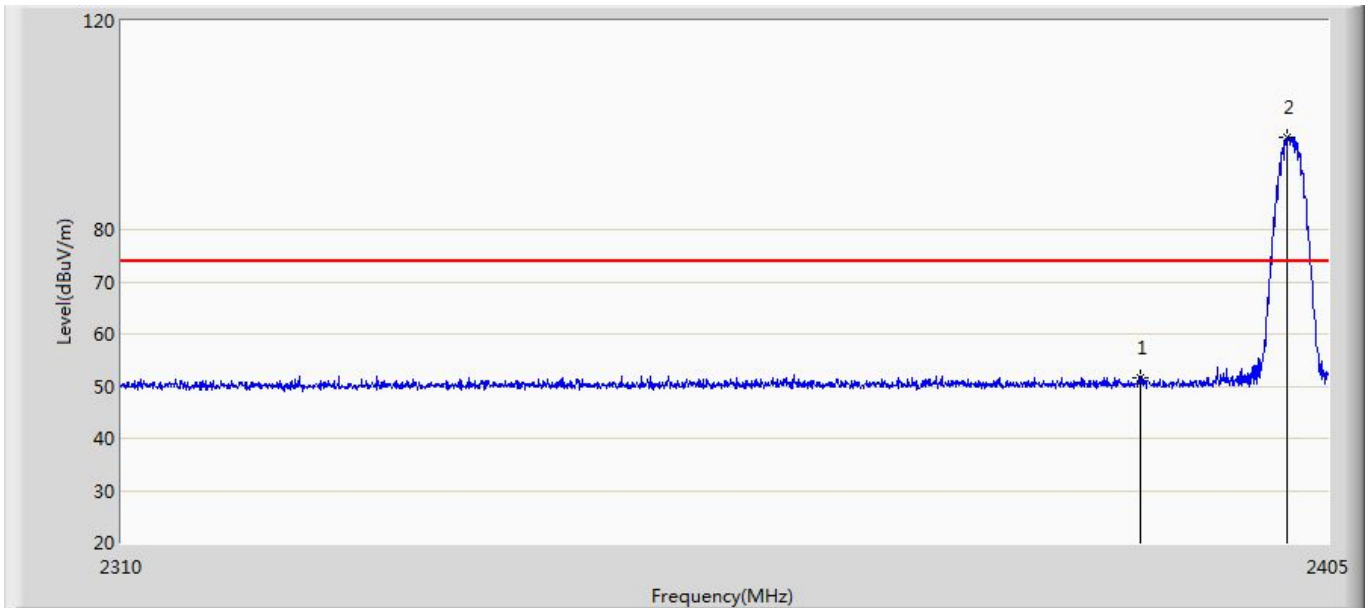

No	Mark	Frequency (MHz)	Measure Level (dBuV/m)	Reading Level (dBuV)	Over Limit (dB)	Limit (dBuV/m)	Factor (dB)	Type
1		2390.000	51.452	15.770	-22.548	74.000	35.682	PK
2	*	2401.770	97.553	61.841	23.553	74.000	35.712	PK

Site: AC5	Time: 2017/03/23 - 11:23
Limit: FCC_Part15.209_RE(3m)	Margin: 0
Probe: Horn_3117_00167055(1-18GHz)	Polarity: Vertical
EUT: Cassia Bluetooth Router	Power: 120V/60Hz
Note: Mode 1:Transmit at 2402MHz by BLE	

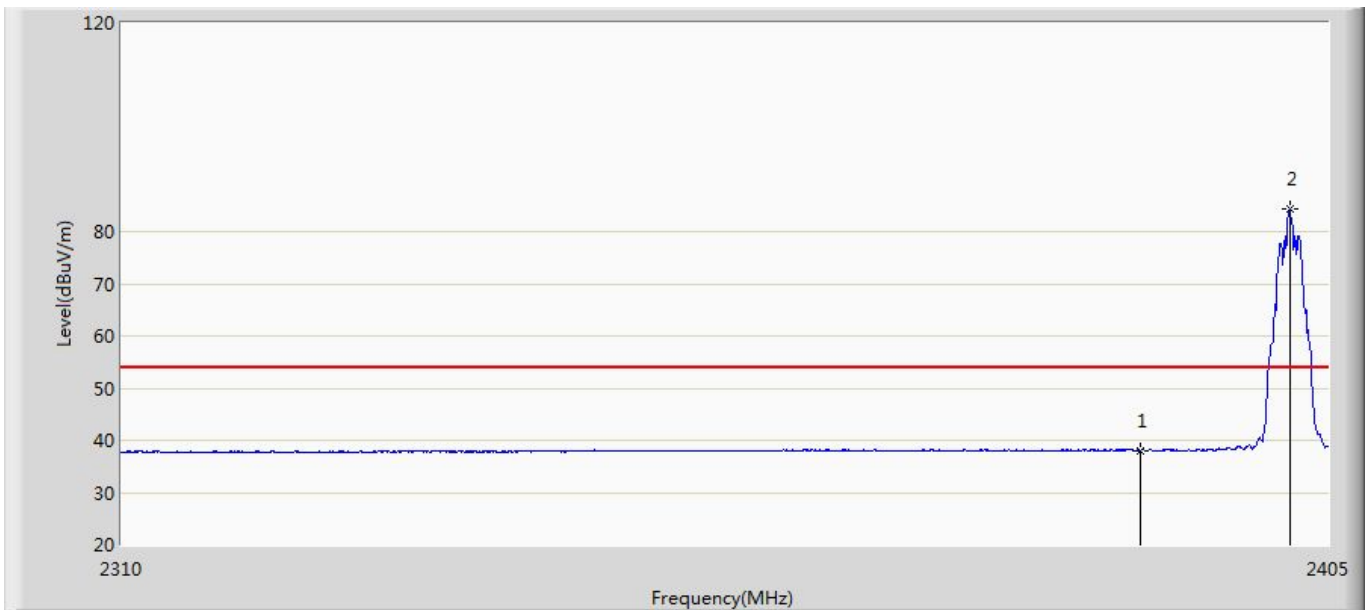

No	Mark	Frequency (MHz)	Measure Level (dBuV/m)	Reading Level (dBuV)	Over Limit (dB)	Limit (dBuV/m)	Factor (dB)	Type
1		2390.000	38.110	2.428	-15.890	54.000	35.682	AV
2	*	2401.913	84.232	48.520	30.232	54.000	35.712	AV

Site: AC5	Time: 2017/03/23 - 11:25
Limit: FCC_Part15.209_RE(3m)	Margin: 0
Probe: Horn_3117_00167055(1-18GHz)	Polarity: Horizontal
EUT: Cassia Bluetooth Router	Power: 120V/60Hz
Note: Mode 1:Transmit at 2480MHz by BLE	

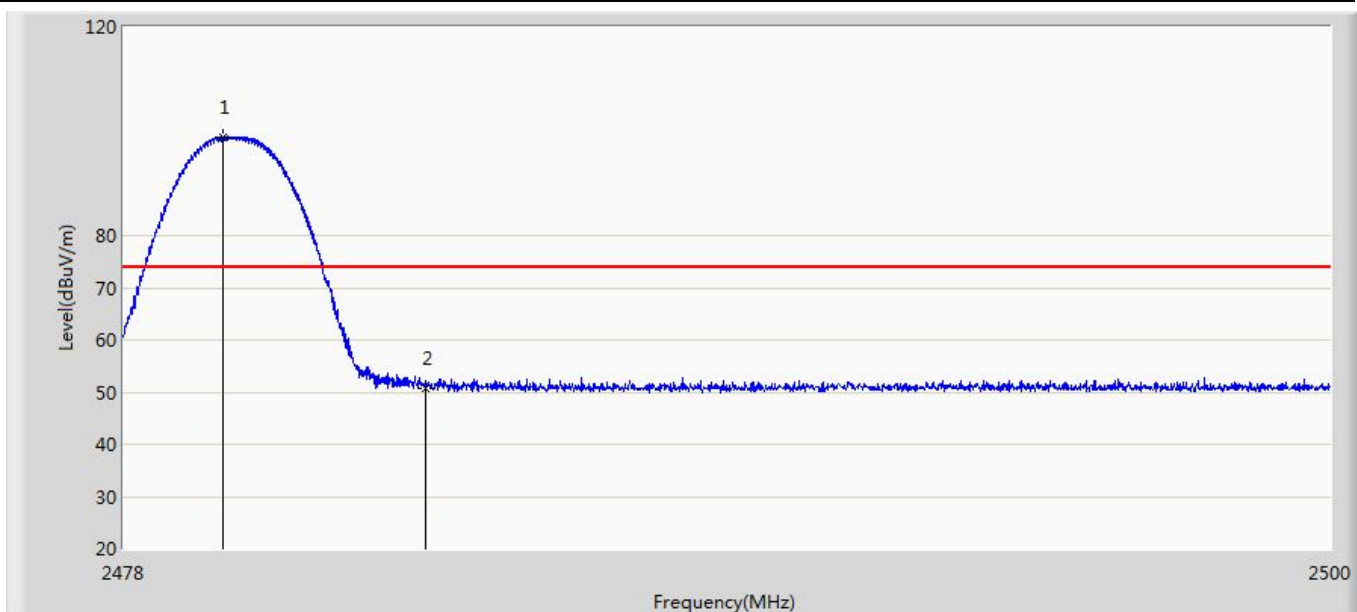

No	Mark	Frequency (MHz)	Measure Level (dBuV/m)	Reading Level (dBuV)	Over Limit (dB)	Limit (dBuV/m)	Factor (dB)	Type
1	*	2479.804	98.820	62.955	24.820	74.000	35.865	PK
2		2483.500	50.849	14.957	-23.151	74.000	35.891	PK

Site: AC5	Time: 2017/03/23 - 11:27
Limit: FCC_Part15.209_RE(3m)	Margin: 0
Probe: Horn_3117_00167055(1-18GHz)	Polarity: Horizontal
EUT: Cassia Bluetooth Router	Power: 120V/60Hz
Note: Mode 1:Transmit at 2480MHz by BLE	

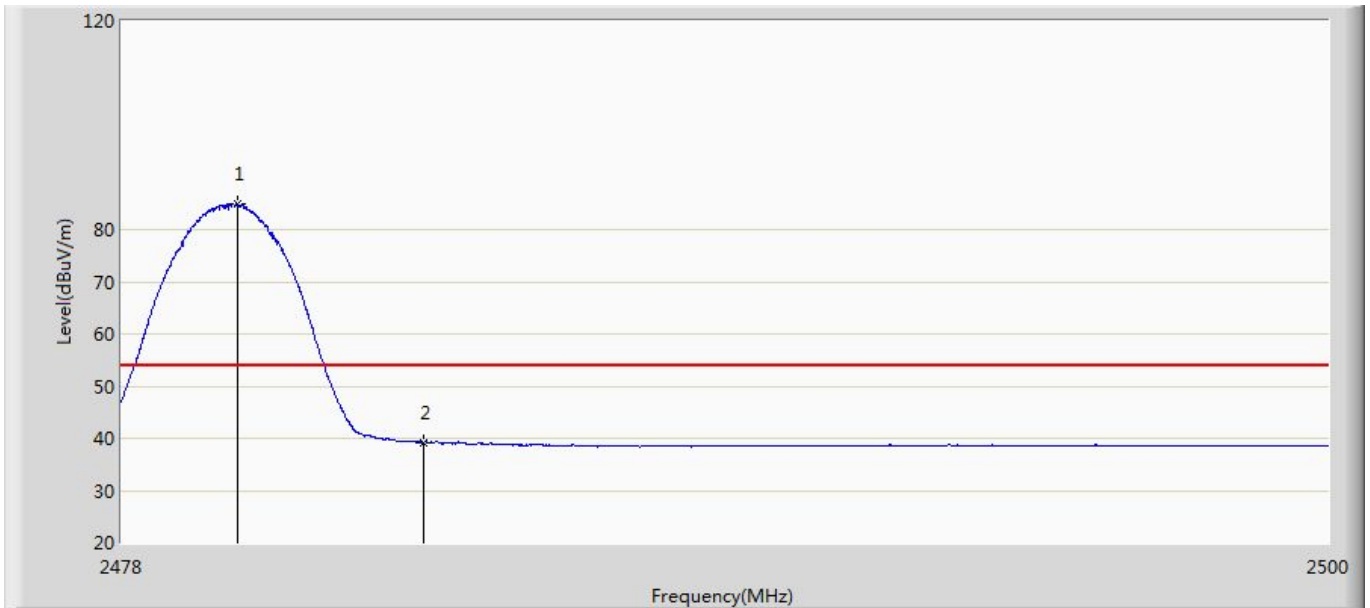

No	Mark	Frequency (MHz)	Measure Level (dBuV/m)	Reading Level (dBuV)	Over Limit (dB)	Limit (dBuV/m)	Factor (dB)	Type
1	*	2480.112	84.810	48.943	30.810	54.000	35.867	AV
2		2483.500	39.234	3.342	-14.766	54.000	35.891	AV

Site: AC5	Time: 2017/03/23 - 11:29
Limit: FCC_Part15.209_RE(3m)	Margin: 0
Probe: Horn_3117_00167055(1-18GHz)	Polarity: Vertical
EUT: Cassia Bluetooth Router	Power: 120V/60Hz
Note: Mode 1:Transmit at 2480MHz by BLE	

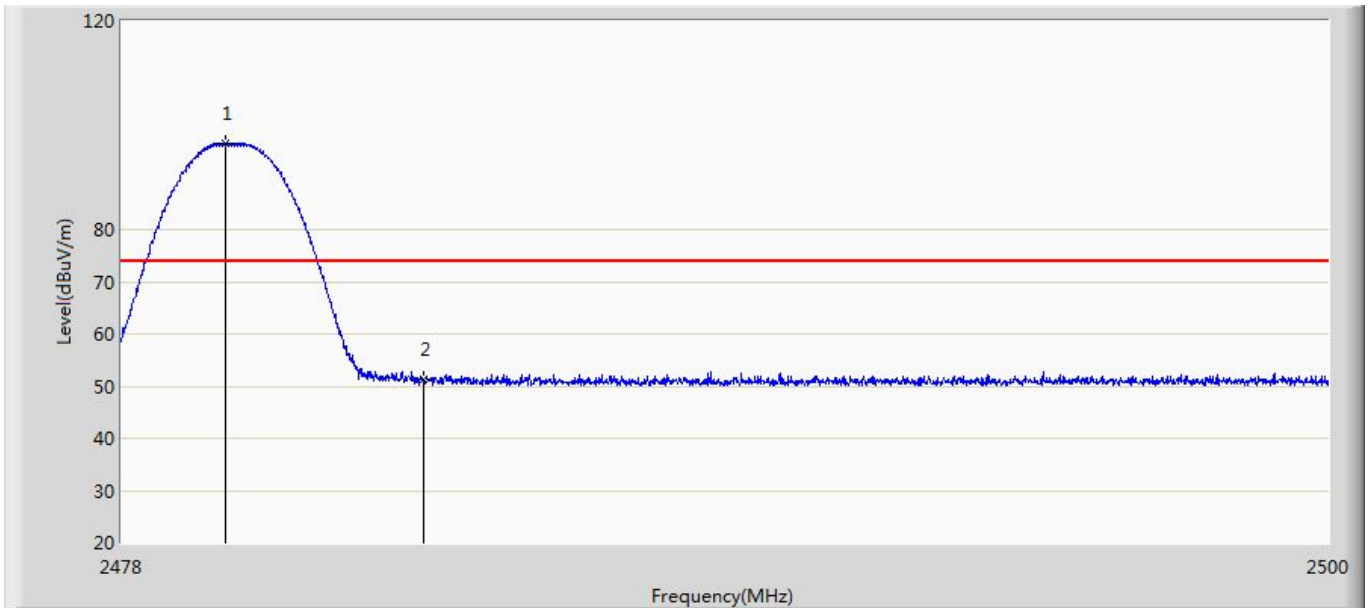

No	Mark	Frequency (MHz)	Measure Level (dBuV/m)	Reading Level (dBuV)	Over Limit (dB)	Limit (dBuV/m)	Factor (dB)	Type
1	*	2479.903	96.617	60.751	22.617	74.000	35.866	PK
2		2483.500	51.382	15.490	-22.618	74.000	35.891	PK

Site: AC5	Time: 2017/03/23 - 11:31
Limit: FCC_Part15.209_RE(3m)	Margin: 0
Probe: Horn_3117_00167055(1-18GHz)	Polarity: Vertical
EUT: Cassia Bluetooth Router	Power: 120V/60Hz
Note: Mode 1:Transmit at 2480MHz by BLE	

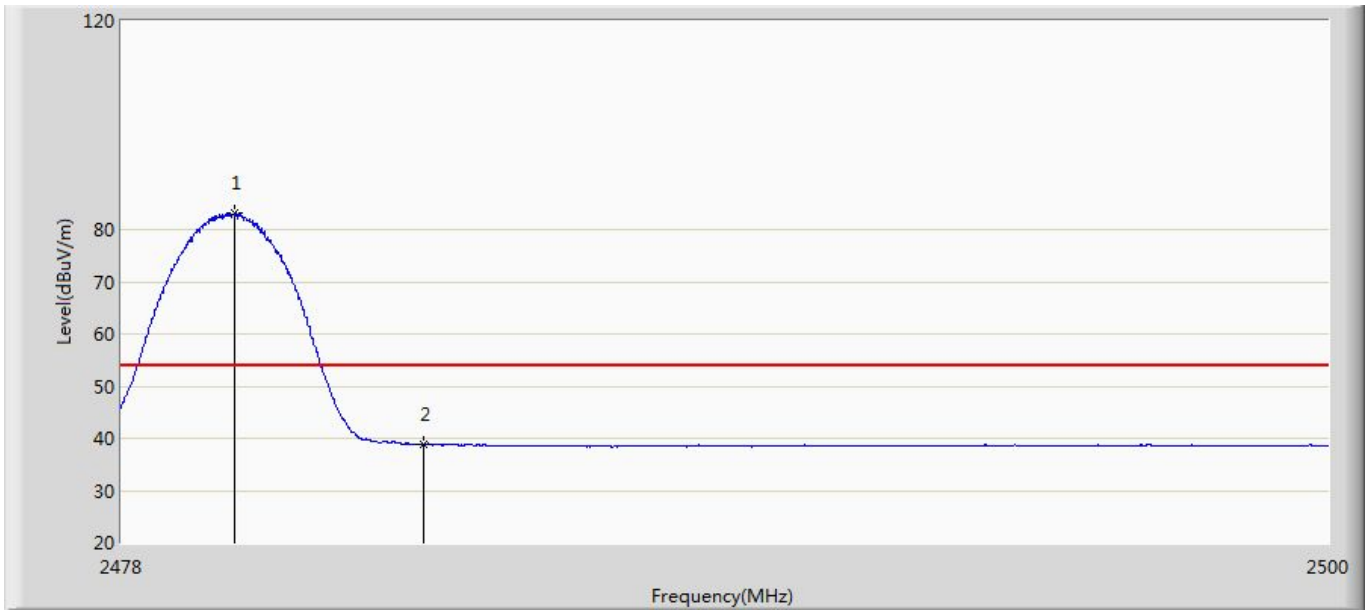

No	Mark	Frequency (MHz)	Measure Level (dBuV/m)	Reading Level (dBuV)	Over Limit (dB)	Limit (dBuV/m)	Factor (dB)	Type
1	*	2480.046	83.222	47.355	29.222	54.000	35.866	AV
2		2483.500	38.795	2.903	-15.205	54.000	35.891	AV

7. Occupied Bandwidth

7.1. Test Equipment

Occupied Bandwidth / TR-8					
Instrument	Manufacturer	Type No.	Serial No.	Cal. Date	Cal. Due Date
Spectrum Analyzer	Agilent	N9010A	MY48030494	2017.02.04	2018.02.03
EXA Spectrum Analyzer	Keysight	N9010A	MY55370495	2017.04.09	2018.04.08
MXA Signal Analyzer	Keysight	N9020A	MY56060147	2017.04.09	2018.04.08
Temperature/Humidity Meter	zhichen	ZC1-2	TR8-TH	2017.04.10	2018.04.09

Note: All equipment are calibrated with traceable calibrations. Each calibration is traceable to the national or international standards.

7.2. Test Setup

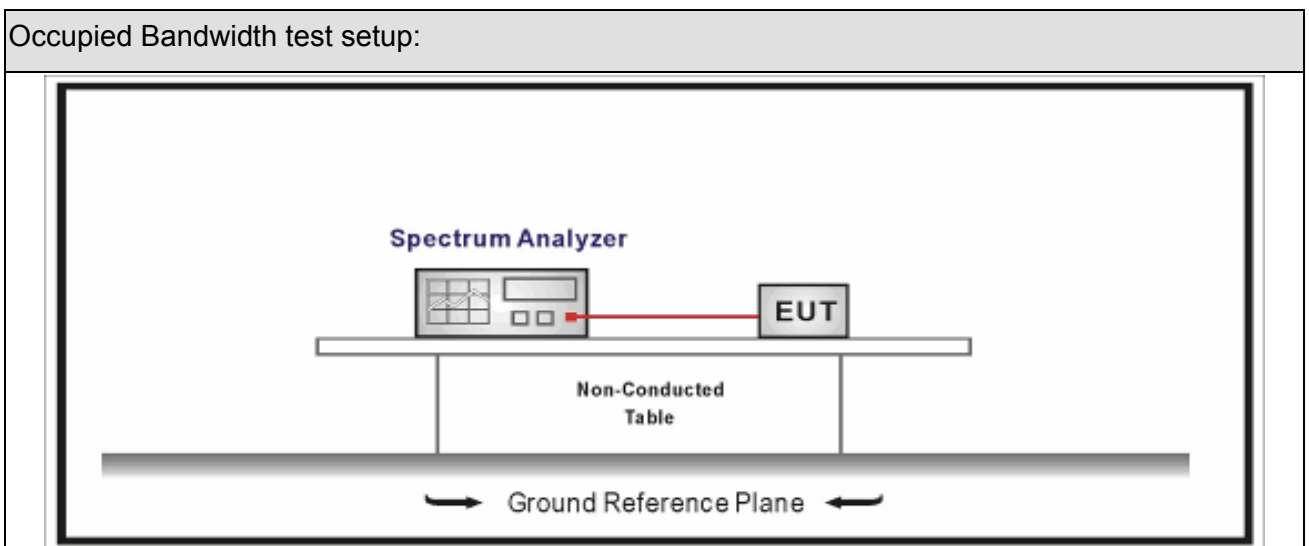



7.3. Limit

Occupied Bandwidth
Systems using digital modulation techniques operate in the 2400-2483.5 MHz .The minimum 6 dB bandwidth shall be at least 500 kHz

7.4. Test Procedure

Test Method			
	Reference Rule	Chapter	Description
<input checked="" type="checkbox"/>	ANSI C63.10	11.8	DTS bandwidth
	<input type="checkbox"/> ANSI C63.10	11.8.1	Option 1
	<input checked="" type="checkbox"/> ANSI C63.10	11.8.2	Option 2

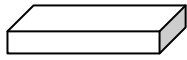
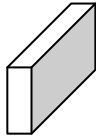
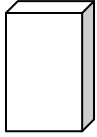
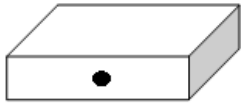
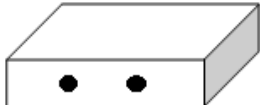
7.5. EUT test definition

Item	Occupied Bandwidth			
Device Category	<input type="checkbox"/>	Fixed point-to-point		
	<input type="checkbox"/>	Emit multiple directional beams, simultaneously or sequentially		
	<input checked="" type="checkbox"/>	Other cases		
Test mode	Mode 1			
Test method	<input type="checkbox"/>	Radiated		
		X Axis	Y Axis	Z Axis
				
		Worst Axis <input type="checkbox"/>	Worst Axis <input type="checkbox"/>	Worst Axis <input type="checkbox"/>
	<input checked="" type="checkbox"/>	Conducted		
	<input checked="" type="checkbox"/>	Chain 0		
				
	<input type="checkbox"/>	Chain 0	Chain 1	
				
	<input type="checkbox"/>	Chain 0	Chain 1	Chain 2
				

7.6. Test Result

Product Name	: Cassia Bluetooth Router	Power	: AC 120V/60Hz
Test Mode	: Mode 1	Test Site	: TR-8
Test Date	: 2017.05.25		

Mode	CH.	Test Freq. (MHz)	99% Occupied Bandwidth (kHz)	6dB Occupied Bandwidth (kHz)	Limit (kHz)	Result
1	00	2402	995.37	511.1	>500	Pass
1	19	2440	992.84	510.0	>500	Pass
1	39	2480	983.21	510.5	>500	Pass

Note : The worst case of Occupied Bandwidth as below:

Mode 1 CH19 (2440MHz)

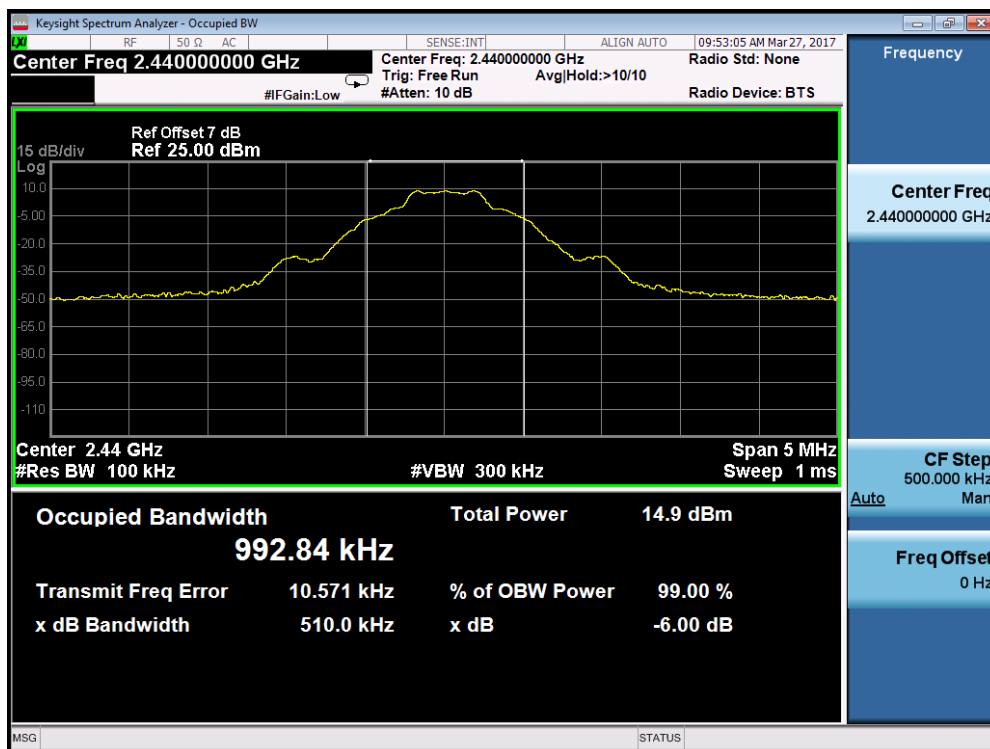

8. Fundamental emission output power

8.1. Test Equipment

Fundamental emission output power/ TR-8					
Instrument	Manufacturer	Type No.	Serial No.	Cal. Date	Cal. Due Date
Spectrum Analyzer	Agilent	E4446A	MY45300103	2017.01.04	2018.01.03
Spectrum Analyzer	Agilent	N9010A	MY48030494	2017.01.04	2018.01.03
Wideband Peak Power Meter	Anritsu	ML2495A	0905006	2016.10.14	2017.10.13
Power Sensor	Anritsu	MA2411B	0846014	2016.10.14	2017.10.13
Temperature/Humidity Meter	zhicheng	ZC1-2	TR8-TH	2017.04.10	2018.04.09

Note: All equipment are calibrated with traceable calibrations. Each calibration is traceable to the national or international standards.

8.2. Test Setup

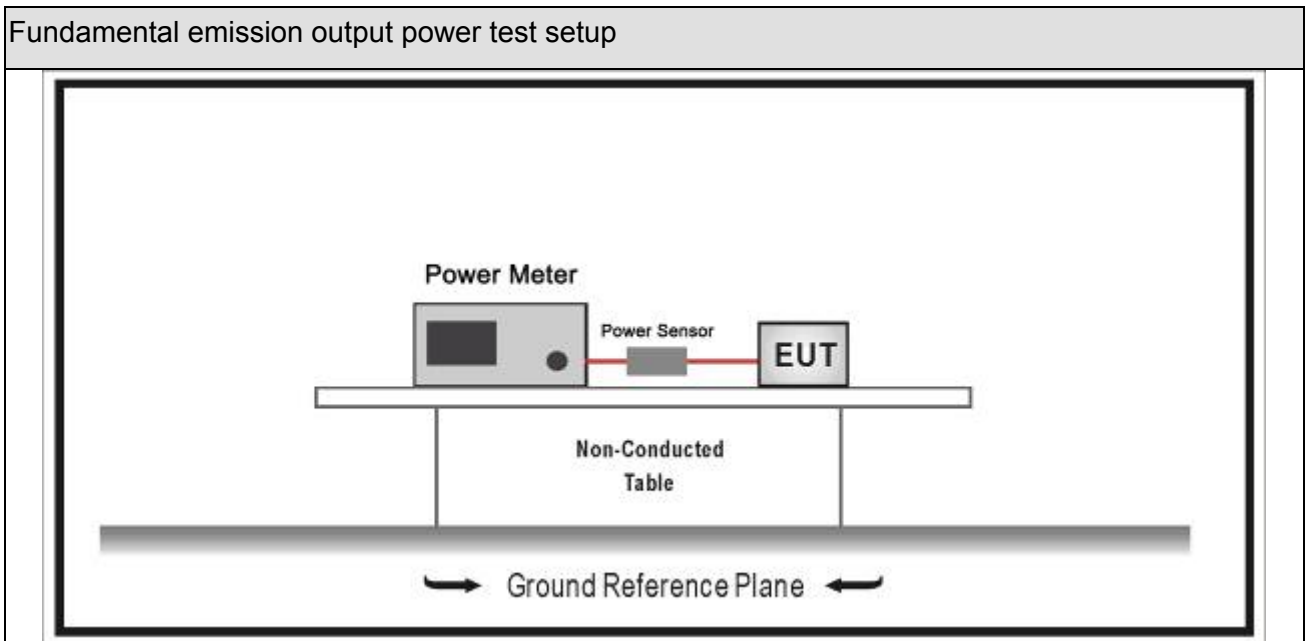



8.3. Limit

Fundamental emission output power Limit		
<input checked="" type="checkbox"/>	$G_{TX} < 6\text{dBi}$	$P_{out} \leq 30\text{dBm}$
<input type="checkbox"/>	$G_{TX} > 6\text{dBi}$	
<input type="checkbox"/>	Non-Fix point-point	$P_{out} \leq 30 - (G_{TX} - 6)$
<input type="checkbox"/>	Fix point-point	$P_{out} \leq 30 - [(G_{TX} - 6)]/3$
<input type="checkbox"/>	Point-to-multipoint	$P_{out} \leq 30 - (G_{TX} - 6)$
<input type="checkbox"/>	Overlap Beams	$P_{out} \leq 30 - [(G_{TX} - 6)]/3$
<input type="checkbox"/>	Aggregate power transmitted simultaneously on all beams	$P_{out} \leq 30 - [(G_{TX} - 6)]/3$
<input type="checkbox"/>	single directional beam	$P_{out} \leq 30 - [(G_{TX} - 6)]/3 + 8\text{dB}$
<p>Note 1 : G_{TX} directional gain of transmitting antennas.</p> <p>Note 2 : P_{out} is maximum peak conducted output power .</p>		

8.4. Test Procedure

Fundamental emission output power Test Method				
	References Rule		Chapter	Description
<input checked="" type="checkbox"/>	ANSI C63.10		11.9	Fundamental emission output power
	<input checked="" type="checkbox"/>	ANSI C63.10	11.9.1	Maximum peak conducted output power
	<input type="checkbox"/>	ANSI C63.10	11.9.1.1	RBW \geq DTS bandwidth
	<input type="checkbox"/>	ANSI C63.10	11.9.1.2	Integrated band power method
	<input checked="" type="checkbox"/>	ANSI C63.10	11.9.1.3	PKPM1 Peak power meter method
	<input type="checkbox"/>	ANSI C63.10	11.9.2	Maximum conducted (average) output power
	<input type="checkbox"/>	ANSI C63.10	11.9.2.2	Measurement using a spectrum analyzer (SA)
	<input type="checkbox"/>	ANSI C63.10	11.9.2.2.2	Method AVGSA-1(Duty cycle \geq 98%)
	<input type="checkbox"/>	ANSI C63.10	11.9.2.2.3	Method AVGSA-1A(Duty cycle \geq 98%)
	<input type="checkbox"/>	ANSI C63.10	11.9.2.2.4	Method AVGSA-2(Duty cycle \leq 98%)
	<input type="checkbox"/>	ANSI C63.10	11.9.2.2.5	Method AVGSA-2A(Duty cycle \leq 98%)
	<input type="checkbox"/>	ANSI C63.10	11.9.2.2.4	Method AVGSA-3
	<input type="checkbox"/>	ANSI C63.10	11.9.2.2.5	Method AVGSA-3A
	<input type="checkbox"/>	ANSI C63.10	11.9.2.3	Measurement using a power meter (PM)
	<input type="checkbox"/>	ANSI C63.10	11.9.2.3.1	Method AVGPM
	<input type="checkbox"/>	ANSI C63.10	11.9.2.3.2	Method AVGPM-G

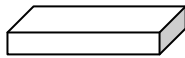
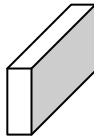
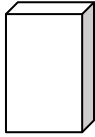
8.5. EUT test definition

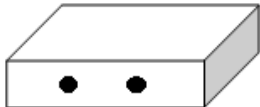
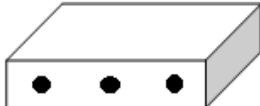
Item	Fundamental emission output power			
Device Category	<input type="checkbox"/>	Fixed point-to-point		
	<input type="checkbox"/>	Emit multiple directional beams, simultaneously or sequentially		
	<input checked="" type="checkbox"/>	Other cases		
Test mode	Mode 1			
Test method	<input type="checkbox"/>	Radiated		
		X Axis	Y Axis	Z Axis
				
		Worst Axis <input type="checkbox"/>	Worst Axis <input type="checkbox"/>	Worst Axis <input type="checkbox"/>
	<input checked="" type="checkbox"/>	Conducted		
	<input checked="" type="checkbox"/>	Chain 0		
				
	<input type="checkbox"/>	Chain 0	Chain 1	
				
	<input type="checkbox"/>	Chain 0	Chain 1	Chain 2
				

8.6. Test Result

Product Name	: Cassia Bluetooth Router	Power	: AC 120V/60Hz
Test Mode	: Mode 1	Test Site	: TR-8
Test Date	: 2017.03.25		

Mode	Channel	Test Frequency (MHz)	Measurement Power Output (dBm)	Limit (dBm)	Result
1	00	2402	7.884	30	Pass
1	19	2440	9.168	30	Pass
1	39	2480	8.304	30	Pass

Mode	Channel	Test Frequency (MHz)	Measurement Power Output (dBm)	Antenna Gain (dBi)	E.I.R.P	Limit (dBm)	Result
1	00	2402	7.884	5	12.884	36	Pass
1	19	2440	9.168	5	14.168	36	Pass
1	39	2480	8.304	5	13.304	36	Pass

E.I.R.P= Measurement Power Output + Antenna Gain

9. Power Spectral Density

9.1. Test Equipment

Power Spectral Density / TR-8					
Instrument	Manufacturer	Type No.	Serial No.	Cal. Date	Cal. Due Date
Spectrum Analyzer	Agilent	N9010A	MY48030494	2017.02.04	2018.02.03
EXA Spectrum Analyzer	Keysight	N9010A	MY55370495	2017.04.09	2018.04.08
MXA Signal Analyzer	Keysight	N9020A	MY56060147	2017.04.09	2018.04.08
Temperature/Humidity Meter	zhichen	ZC1-2	TR8-TH	2017.04.10	2018.04.09

Note: All equipment are calibrated with traceable calibrations. Each calibration is traceable to the national or international standards.

9.2. Test Setup

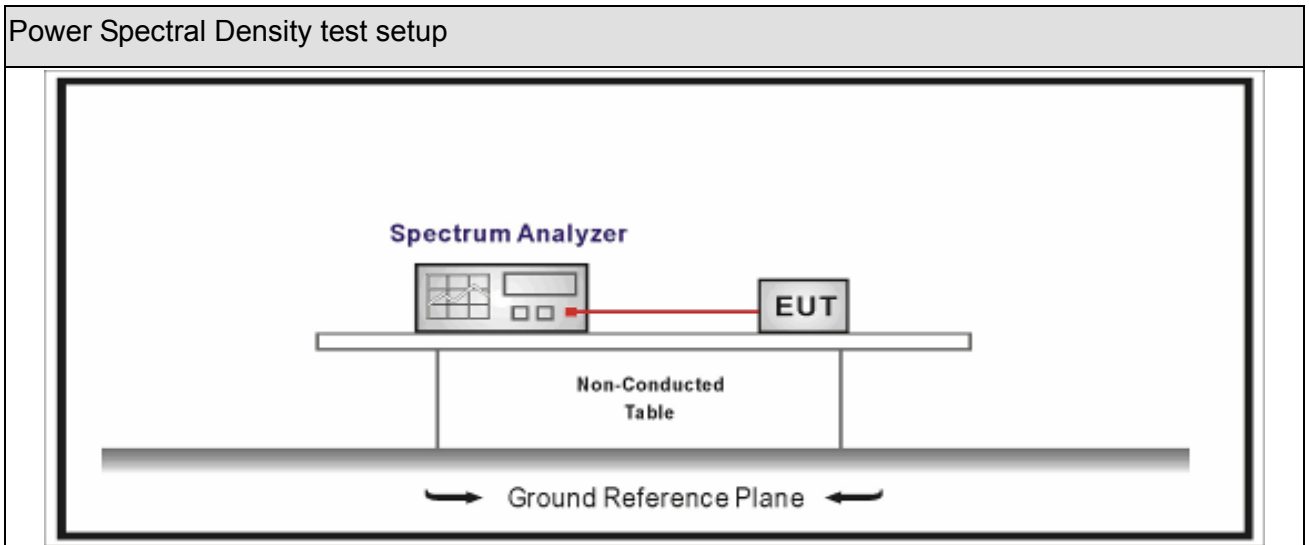

9.3. Limit

Power Spectral Density Limit
Power Spectral Density $\leq 8\text{dBm}/3\text{kHz}$

9.4. Test Procedure

Power Spectral Density Test Method			
	References Rule	Chapter	Description
<input checked="" type="checkbox"/>	ANSI C63.10	11.10	Maximum power spectral density level in the fundamental emission
<input checked="" type="checkbox"/>	ANSI C63.10	11.10.2	Method PKPSD (peak PSD)
<input type="checkbox"/>	ANSI C63.10	11.10.3	Method AVGPSD-1(Duty cycle \geq 98%)
<input type="checkbox"/>	ANSI C63.10	11.10.4	Method AVGPSD-1A(Duty cycle \geq 98%)
<input type="checkbox"/>	ANSI C63.10	11.10.5	Method AVGPSD-2(Duty cycle $<$ 98%)
<input type="checkbox"/>	ANSI C63.10	11.10.6	Method AVGPSD-2A(Duty cycle $<$ 98%)
<input type="checkbox"/>	ANSI C63.10	11.10.7	Method AVGPSD-3
<input type="checkbox"/>	ANSI C63.10	11.10.8	Method AVGPSD-3A

9.5. EUT test definition

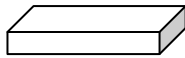
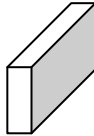
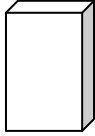
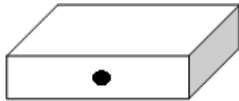
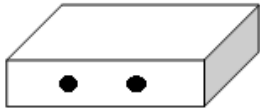
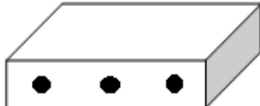
Item	Power Spectral Density Test Method			
Device Category	<input type="checkbox"/>	Fixed point-to-point		
	<input type="checkbox"/>	Emit multiple directional beams, simultaneously or sequentially		
	<input checked="" type="checkbox"/>	Other cases		
Test mode	Mode 1			
Test method	<input type="checkbox"/>	Radiated		
		X Axis	Y Axis	Z Axis
				
		Worst Axis <input type="checkbox"/>	Worst Axis <input type="checkbox"/>	Worst Axis <input type="checkbox"/>
	<input checked="" type="checkbox"/>	Conducted		
	<input checked="" type="checkbox"/>	Chain 0		
				
	<input type="checkbox"/>	Chain 0	Chain 1	
				
	<input type="checkbox"/>	Chain 0	Chain 1	Chain 2
				

9.6. Test Result

Product Name	: Cassia Bluetooth Router	Power	: AC 120V/60Hz
Test Mode	: Mode 1	Test Site	: TR-8
Test Date	: 2017.05.25		

Mode	Channel	Test Frequency (MHz)	Measurement PSD (dBm/3kHz)	Total PSD (dBm/3kHz)	Limit (dBm/3kHz)	Result
1	00	2402	-4.135	-4.135	8	Pass
1	19	2440	-2.853	-2.853	8	Pass
1	39	2480	-3.479	-3.479	8	Pass

Note : The worst case of Power Spectral Density as below:

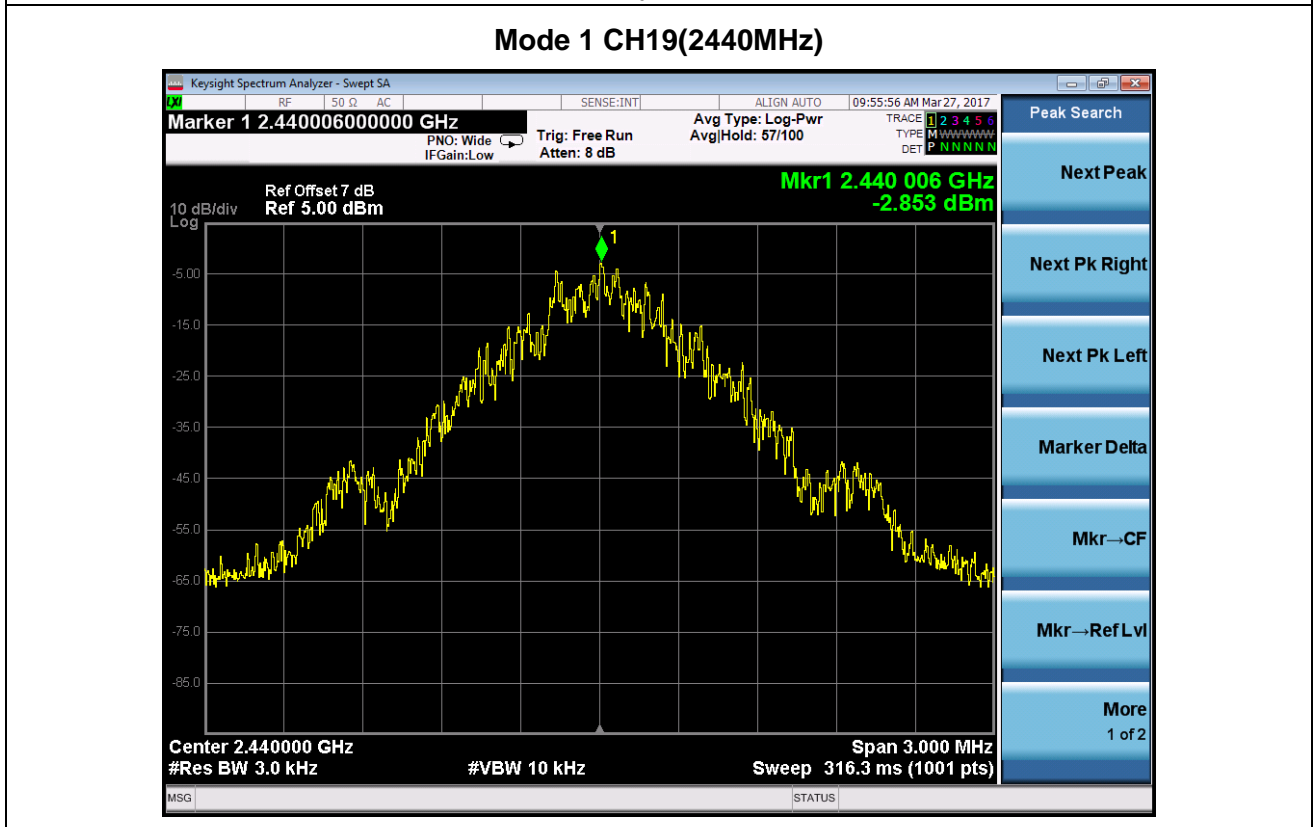

10. Antenna Requirement

10.1. Limit

Antenna Requirement Limit
<p>An intentional radiator shall be designed to ensure that no antenna other than that furnished by the responsible party shall be used with the device. The use of a permanently attached antenna or of an antenna that uses a unique coupling to the intentional radiator shall be considered sufficient to comply with the provisions of this section. The manufacturer may design the unit so that a broken antenna can be replaced by the user, but the use of a standard antenna jack or electrical connector is prohibited. This requirement does not apply to carrier current devices or to devices operated under the provisions of §15.211, §15.213, §15.217, §15.219, or §15.221. Further, this requirement does not apply to intentional radiators that must be professionally installed, such as perimeter protection systems and some field disturbance sensors, or to other intentional radiators which, in accordance with §15.31(d), must be measured at the installation site. However, the installer shall be responsible for ensuring that the proper antenna is employed so that the limits in this part are not exceeded.</p>

10.2. Antenna Connector Construction

Antenna Connector Construction	
<input checked="" type="checkbox"/>	The use of a permanently attached antenna
<input type="checkbox"/>	The antenna use of a unique coupling to the intentional radiator
<input type="checkbox"/>	The use of a nonstandard antenna jack or electrical connector
Please refer to the attached document "Internal Photograph" to show the antenna connector.	

_____ The End _____