

FCC PART 22/24 TEST REPORT

for

GPS Tracker

Model No.: RMBU_3GTR

FCC ID: 2ALG8RMBU3GTR

of

Applicant: **Roambee Corporation**

Address: **3120 De La Cruz Blvd. Suite 121, Santa Clara,
California 95054 United States**

Tested and Prepared

by

Worldwide Testing Services (Taiwan) Co., Ltd.

FCC Registration No.: 930600

Industry Canada filed test laboratory Reg. No. IC 5679A-1, IC 5107A-1

A2LA Accredited No.: 2732.01



Report No.: W6M21703-16710-P-2224

6F, NO. 58, LANE 188, RUEY-KUANG RD., NEIHU TAIPEI 114, TAIWAN, R.O.C.
TEL: 886-2-66068877 FAX: 886-2-66068879 E-mail: wts@wts-lab.com



Worldwide Testing Services(Taiwan) Co., Ltd.

Report Number: W6M21703-16710-P-2224
FCC ID: 2ALG8RMBU3GTR

Certification of Test Report

Applicant : Roambee Corporation
3120 De La Cruz Blvd. Suite 121, Santa Clara,
California 95054 United States
Manufacturer : VVDN Technologies Pvt. Ltd
B-22, Infocity Sector-34, Gurgaon-122001, Haryana, India

Tested Equipment :
Type Description : GPS Tracker
Model Number : RMBU_3GTR
Brand Name : ROAMBEE
Operation Frequency : Band: 850 MHz: 824.2 - 848.8 MHz
Band: 1900 MHz: 1850.2 - 1909.8 MHz
WCDMA Band II: 1852.4 – 1907.6 MHz
WCDMA Band V: 826.4 – 846.6 MHz
RF Output Power: : Band 850 MHz: 10.79 dBm (ERP)
Band 1900 MHz: 5.20 dBm (EIRP)
WCDMA Band II: 25.50 dBm (EIRP)
WCDMA Band V: 17.16 dBm (ERP)
Power Supply : Charge 120 VAC (Mode 2, Mode 3)
Battery: 6 VDC, 4500 mAh (Mode 1)
3.7 VDC, 1150 mAh (Mode 2)
3.7 VDC, 9300 mAh (Mode 3)

Regulation Applied : 47CFR Part 22 (2015-10) and Part 24 (2015-10)

Test Method : 47CFR Part 2 (2015), TIA/EIA-603C (2010) and
ANSI C63.4 (2014)

I HEREBY CERTIFY THAT: The test results written in this report were derived conscientiously in accordance with the requirements and procedures of 47CFR Part 2(2015), TIA/EIA-603C (2010), and it was found that the device described above is in compliance with the applicable limits specified in 47CFR Part 22/24.

Note:

1. The result of this test report is valid only in connection to the sample has been tested at the laboratory of Worldwide Testing Services (Taiwan) Co. Ltd.
2. This test report shall always be duplicated in full pages unless the written approval of the testing laboratory is obtained.

Test Engineer:

June 01, 2017 Mark Cheng

Date WTS-Lab. Name Signature

Technical responsibility for area of testing:

June 01, 2017 Kevin Wang

Date WTS Name Signature



Report Number: W6M21703-16710-P-2224

FCC ID: 2ALG8RMBU3GTR

TABLE OF CONTENTS

- 1. SUMMARY3**
 - 1.1 DESCRIPTION OF TESTED EQUIPMENT3
 - 1.2 DATE OF TESTING PROCESSING3
 - 1.3 MODIFICATION INFORMATION3
 - 1.4 TEST STANDARDS.....3
 - 1.5 SUMMARY OF TEST RESULT.....4
- 2. GENERAL INFORMATION5**
 - 2.1 TESTING LABORATORY5
 - 2.1.1 Location5
 - 2.1.2 Details of accreditation status5
 - 2.1.3 Test location, where different from Worldwide Testing Services (Taiwan) Co., Ltd.5
 - 2.2 DETAILS OF APPROVAL HOLDER.....5
 - 2.3 DESCRIPTION OF TESTED SYSTEM.....6
 - 2.4 TEST ENVIRONMENT6
 - 2.5 GENERAL TEST REQUIREMENT7
 - 2.6 TEST EQUIPMENT LIST8
- 3. RF POWER OUTPUT11**
 - 3.1 TEST PROCEDURE.....11
 - 3.1.1 Conducted Method.....11
 - 3.1.2 Radiated Method.....12
 - 3.2 TEST RESULTS14
- 4. MODULATION CHARACTERISTICS28**
 - 4.1 TEST PROCEDURE.....28
 - 4.2 TEST RESULTS28
- 5. OCCUPIED BANDWIDTH.....29**
 - 5.1 TEST PROCEDURE.....29
 - 5.2 TEST RESULTS29
- 6. SPURIOUS EMISSIONS AT ANTENNA TERMINALS42**
 - 6.1 TEST PROCEDURE.....42
 - 6.2 TEST RESULTS42
 - 6.3 EXPLANATION OF TEST RESULT.....90
 - 6.4 CALCULATION OF LIMIT FOR SPURIOUS AT ANTENNA TERMINALS.....90
- 7. FIELD STRENGTH OF SPURIOUS RADIATION.....91**
 - 7.1 TEST PROCEDURE.....91
 - 7.2 TEST RESULTS91
 - 7.3 EXPLANATION OF TEST RESULT.....91
 - 7.4 CALCULATION OF LIMIT FOR FIELD STRENGTH OF SPURIOUS91
 - 7.5 TEST RESULT OF BAND EDGE EMISSIONS92
- 8. FREQUENCY STABILITY108**
 - 8.1 TEST PROCEDURE.....108



Report Number: W6M21703-16710-P-2224

FCC ID: 2ALG8RMBU3GTR

8.2	TEST RESULTS	109
8.2.1	<i>Frequency Stability vs. Temperature</i>	109
9	MAXIMUM PERMISSIBLE EXPOSURE.....	111
9.1	APPLICABLE STANDARD	111
9.2	MPE CALCULATION METHOD	111

Appendix



Report Number: W6M21703-16710-P-2224

FCC ID: 2ALG8RMBU3GTR

1. Summary

1.1 Description of tested equipment

This test report only contains test requirements specified in 47CFR Part 22 and Part 24 for GSM function; please refer to separate test report with respect to the relevant test standard and specification.

1.2 Date of testing processing

Test sample received: April 06, 2017

Test finished: June 01, 2017

Other Information: None

1.3 Modification Information

No modification was made during the all test items been performed.

1.4 Test standards

Technical standard: **FCC Part 2(2015), TIA/EIA-603C (2010), ANSI C63.4 (2014)
47CFR Part 22 (2015-10), and Part 24 (2015-10)**

Deviation from test standard: None



Report Number: W6M21703-16710-P-2224

FCC ID: 2ALG8RMBU3GTR

1.5 Summary of test result

Band: 850 MHz

Section in this Report	Test Item	FCC relevant Section	Verdict
3.2	RF Power Output (Effective radiated power)	2.1046(a), 22.913(a)	Pass
4.2	Modulation characteristics	2.1047	Not Required
5.2	Occupied bandwidth	2.1049(h)	Pass
6.2	Spurious emissions at antenna terminals	22.917(a), 2.1051	Pass
7.2	Field strength of spurious radiation	22.917(a), 2.1053	Pass
7.5	Band Edge emissions	22.917(a)	Pass
8.2	Frequency stability	2.1055 22.355	Pass

Band: 1900 MHz

Section in this Report	Test Item	FCC Relevant Section	Verdict
3.2	RF Power Output (Equivalent isotropically radiated power)	2.1046(a), 24.232	Pass
4.2	Modulation characteristics	2.1047	Not Required
5.2	Occupied bandwidth	2.1049(h) 24.238(b)	Pass
6.2	Spurious emissions at antenna terminals	24.238(a), 2.1051	Pass
7.2	Field strength of spurious radiation	24.238(a), 2.1053	Pass
7.5	Band Edge emissions	24.238(b)	Pass
8.2	Frequency stability	2.1055 24.235	Pass



Report Number: W6M21703-16710-P-2224

FCC ID: 2ALG8RMBU3GTR

2. General Information

2.1 Testing laboratory

2.1.1 Location

OATS
No.5-1, Shuang Sing Village,
LiShuei Rd., Wanli Township,
Taipei County 207, Taiwan (R.O.C.)
Company
Worldwide Testing Services (Taiwan) Co., Ltd.
6F, NO. 58, LANE 188, RUEY-KUANG RD.
NEIHU, TAIPEI 114, TAIWAN R.O.C.
Tel : 886-2-66068877
Fax : 886-2-66068879

2.1.2 Details of accreditation status

Accredited testing laboratory
A2LA-registration number: 2732.01
FCC filed test laboratory Reg. No. 930600
Industry Canada filed test laboratory Reg. No. IC 5679A-1, IC 5107A-1

2.1.3 Test location, where different from Worldwide Testing Services (Taiwan) Co., Ltd.

Name: ./.
Accredited number: ./.
Street: ./.
Town: ./.
Country: ./.
Telephone: ./.
Fax: ./.

2.2 Details of approval holder

Name: Roambee Corporation
Street: 3120 De La Cruz Blvd. Suite 121,
Town: Santa Clara, California 95054
Country: United States
Telephone: +1 (408) 663 6655
Fax: +1 (408) 663 6655



Report Number: W6M21703-16710-P-2224
FCC ID: 2ALG8RMBU3GTR

Manufacturer: (if different from applicant)
Name: VVDN Technologies Pvt. Ltd
Street: B-22, Infocity Sector-34,
Town: Gurgaon-122001, Haryana,
Country: India

2.3 Description of Tested System

The EUT was tested alone without the Accessories or Peripherals.

Equipment	Model No.	Series No.	Software	Cable information	Note
No accessories were used with this EUT.					

Frequencies Selected to be investigated:

Band: 850 MHz

Low Frequency (ch 128): 824.2 MHz
Mid Frequency (ch 188): 836.2 MHz
High Frequency (ch 251): 848.8 MHz

Band: 1900 MHz

Low Frequency (ch 512): 1850.2 MHz
Mid Frequency (ch 661): 1880.0 MHz
High Frequency (ch 810): 1909.8 MHz

WCDMA Band II

Low Frequency (ch 9262): 1852.4 MHz
Mid Frequency (ch 9400): 1880.0 MHz
High Frequency (ch 9538): 1907.6 MHz

WCDMA Band V

Low Frequency (ch 4132): 826.4 MHz
Mid Frequency (ch 4183): 836.6 MHz
High Frequency (ch 4233): 846.6 MHz

Antenna Type: Armata 3G FPC Antenna

Antenna Gain: Band 850 MHz & WCDMA Band V: 2.46 dBi
Band: 1900 MHz & WCDMA Band II: 4.06 dBi

Power supply: Charge 120 VAC (Mode 2, Mode 3)
Battery: 6 VDC, 4500 mAh (Mode 1)
3.7 VDC, 1150 mAh (Mode 2)
3.7 VDC, 9300 mAh (Mode 3)

2.4 Test environment

Temperature: 27 °C
Relative humidity content: 54 %
Air pressure: 86-103 Kpa

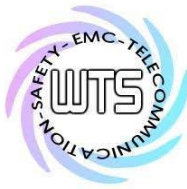

Report Number: W6M21703-16710-P-2224
FCC ID: 2ALG8RMBU3GTR

2.5 General Test Requirement

Radiated Emission: For investigated frequency is equal to or below 1GHz, the RBW and VBW of the spectrum analyzer was 100 kHz and 100 kHz respectively with an appropriate sweep speed.

For investigated frequency is above 1GHz, both of RBW and VBW of the spectrum analyzer were 1 MHz with an appropriate sweep speed. The analyzer was calibrated in dB above a microvolt at the output of the antenna.

The table used for radiated measurements is capable of continuous rotation. The spectrum was scanned from 30 MHz to the frequency specified as follows:

- (1) If the intentional radiator operates below 10 GHz: to the tenth harmonic of the highest fundamental frequency or to 40 GHz, whichever is lower.
- (2) If the intentional radiator operates at or above 10 GHz and below 30 GHz: to the fifth harmonic of the highest fundamental frequency or to 100 GHz, whichever is lower.
- (3) If the intentional radiator operates at or above 30 GHz: to the fifth harmonic of the highest fundamental frequency or to 200 GHz, whichever is lower, unless specified otherwise elsewhere in the rules.

For hand-held devices, a exploratory test was performed with three (3) orthogonal planes to determine the highest emissions.

When an emission was found, the table was rotated to produce the maximum signal strength. At this point, the antenna was raised and lowered from 1m to 4m. The antenna was placed in both the horizontal and vertical planes.

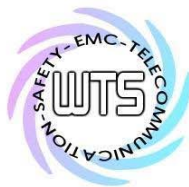

Worldwide Testing Services(Taiwan) Co., Ltd.

Report Number: W6M21703-16710-P-2224

FCC ID: 2ALG8RMBU3GTR

2.6 Test Equipment List

No.	Test equipment	Type	Serial No.	Manufacturer	Cal. Date	Next Cal. Date
ETSTW-CE 001	EMI TEST RECEIVER	ESHS10	842121/013	R&S	2017/5/19	2018/5/19
ETSTW-CE 003	AC POWER SOURCE	APS-9102	D161137	GW	Function Test	
ETSTW-CE 008	HF-EICHLITUNG RF STEP ATTENUATOR 139dB DPSP	334.6010.02	844581/024	R&S	Function Test	
ETSTW-CE 009	TEMP.&HUMIDITY CHAMBER	GTH-225-40-1P-U	MAA0305-009	GIANT FORCE	2016/7/15	2017/7/14
ETSTW-CE 016	TWO-LINE V-NETWORK	ENV216	100050	R&S	2016/9/12	2017/9/11
ETSTW-CE 028	MXE EMI Receiver	N9038A	MY53220110	Agilent	2016/8/26	2017/8/25
ETSTW-RE 003	EMI TEST RECEIVER	ESI 26	831438/001	R&S	2017/5/19	2018/5/18
ETSTW-RE 004	EMI TEST RECEIVER	ESI 40	832427/004	R&S	2017/5/19	2018/5/18
ETSTW-RE 005	EMI TEST RECEIVER	ESVS10	843207/020	R&S	2016/7/4	2017/7/3
ETSTW-RE 012	TUNABLE BANDREJECT FILTER	D.C 0309	146	K&L	Function Test	
ETSTW-RE 013	TUNABLE BANDREJECT FILTER	D.C 0336	397	K&L	Function Test	
ETSTW-RE 018	MICROWAVE HORN ANTENNA	AT4560	27212	AR	2016/6/24	2017/6/23
ETSTW-RE 027	Passive Loop Antenna	6512	00034563	ETS-Lindgren	2016/6/29	2017/6/28
ETSTW-RE 030	Double-Ridged Guide Horn Antenna	3117	00035224	ETS-Lindgren	2017/3/22	2018/3/21
ETSTW-RE 042	Biconical Antenna	HK116	100172	R&S	2017/2/7	2018/2/6
ETSTW-RE 043	Log-Periodic Dipole Antenna	HL223	100166	R&S	2017/4/10	2018/4/9
ETSTW-RE 044	Log-Periodic Antenna	HL050	100094	R&S	2017/4/27	2018/4/26
ETSTW-RE 045	ESA-E SERIES SPECTRUM ANALYZER	E4404B	MY45111242	Agilent	Pre-test Use	
ETSTW-RE 050	Attenuator 10dB	50HF-010-1	None	JFW	2017/3/1	2018/2/28
ETSTW-RE 051	Attenuator 6dB	50HF-006-1	None	JFW	2017/3/1	2018/2/28
ETSTW-RE 053	Attenuator 3dB	50HF-003-1	None	JFW	2017/3/1	2018/2/28
ETSTW-RE 055	SPECTRUM ANALYZER	FSU 26	200074	R&S	2017/3/1	2018/2/28
ETSTW-RE 060	Attenuator 30dB	5015-30	F651012z-01	ATM	2017/3/1	2018/2/28
ETSTW-RE 062	Amplifier Module	CHC 2	None	KMIC	2017/4/12	2018/4/11
ETSTW-RE 064	Bluetooth Test Set	MT8852B-042	6K00005709	Anritsu	Function Test	
ETSTW-RE 069	Double-Ridged Guide Horn Antenna	3117	00069377	ETS-Lindgren	Function Test	
ETSTW-RE 072	CELL SITE TEST SET	8921A	3339A00375	HP	2016/9/8	2017/9/7
ETSTW-RE 088	SOLID STATE AMPLIFIER	KMA180265A01	99057	KMIC	2016/9/20	2017/9/19
ETSTW-RE 091	Match Pad	MDCS1500	None	WOKEN	2017/4/6	2018/4/5
ETSTW-RE 099	DC Block	50DB-007-1	None	JFW	2017/3/1	2018/2/28
ETSTW-RE 112	AC POWER SOURCE	TFC-1005	T-0A023536	T-Power	Function test	
ETSTW-RE 115	2.4GHz Notch Filter	N0124411	473874	MICROWAVE CIRCUITS	2017/1/12	2018/1/11
ETSTW-RE 120	RF Player	MP9200	MP9210-111022	ADIVIC	Function test	



Worldwide Testing Services(Taiwan) Co., Ltd.

Report Number: W6M21703-16710-P-2224

FCC ID: 2ALG8RMBU3GTR

ETSTW-RE 122	SIGNAL GENERATOR	SMF100A	102149	R&S	2017/5/19	2018/5/18
ETSTW-RE 125	5GHz Notch filter	5NSL11-5200/E221.3-O/O	1	K&L Microwave	2016/8/10	2017/8/9
ETSTW-RE 126	5GHz Notch filter	5NSL12-5800/E221.3-O/O	1	K&L Microwave	2016/8/10	2017/8/9
ETSTW-RE 127	RF Switch Box	RFS-01	None	WTS	2017/3/1	2018/2/28
ETSTW-RE 128	5.3GHz Notch filter	N0153001	SN487233	Microwave Circuits	2016/8/10	2017/8/9
ETSTW-RE 129	5.5GHz Notch filter	N0555984	SN487234	Microwave Circuits	2016/8/10	2017/8/9
ETSTW-RE 130	Handheld RF Spectrum Analyzer	N9340A	CN0147000204	Agilent	Pre-test Use	
ETSTW-RE 142	Amplifier	8447D	2805A03378	Agilent	2017/4/12	2018/4/11
ETSTW-RE 143	Humidity Temperature Meter	TES-1260	110104623	TES	2016/8/19	2017/8/18
ETSTW-RE 147	Bi-log Hybrid Antenna	MCTD 2786B	BLB16M04005	ETC	2017/3/22	2018/3/21
ETSTW-EMI 011	USB Compact Modulator	SFC-U	101689	R&S	2017/5/10	2018/5/9
ETSTW-GSM 002	Universal Radio Communication Tester	CMU 200	109439	R&S	2017/2/24	2018/2/23
ETSTW-GSM 003	Radio Communication Analyzer	MT8820C	6201342073	Anritsu	2017/2/10	2018/2/9
ETSTW-GSM 004	Wideband Radio Communication Tester	CMW500	128092	R&S	2016/12/15	2017/12/14
ETSTW-GSM 019	Band Reject Filter	WRCTF824/849-822/851-40/12+9SS	3	WI	2017/1/12	2018/1/11
ETSTW-GSM 020	Band Reject Filter	WRCD1747/1748-1743/1752-32/5SS	1	WI	2017/1/12	2018/1/11
ETSTW-GSM 021	Band Reject Filter	WRCD1879.5/1880.5-1875.5/1884.5-32/5SS	3	WI	2017/1/12	2018/1/11
ETSTW-GSM 022	Band Reject Filter	WRCT901.9/903.1-904.25-50/8SS	1	WI	2017/1/12	2018/1/11
ETSTW-GSM 023	Power Divider	4901.19.A	None	SUHNER	2016/9/14	2017/9/13
ETSTW-Cable 010	BNC Cable	RGS-142	None	THERMAX	2016/9/12	2017/9/11
ETSTW-Cable 011	SMA to N type Cable	RGU-400	None	THERMAX	Pre-test Use NCR	
ETSTW-Cable 012	BNC Cable	RGS-400	None	THERMAX	2016/9/12	2017/9/11
ETSTW-Cable 016	BNC Cable	Switch Box	B Cable 1	Schwarz beck	2017/2/23	2018/2/22
ETSTW-Cable 017	BNC Cable	X Cable	B Cable 2	Schwarz beck	2017/2/23	2018/2/22
ETSTW-Cable 018	BNC Cable	Y Cable	B Cable 3	Schwarz beck	2017/2/23	2018/2/22
ETSTW-Cable 019	BNC Cable	Z Cable	B Cable 4	Schwarz beck	2017/2/23	2018/2/22
ETSTW-Cable 020	N TYPE Cable	OATS Cable 1	N30N30-L335-15M	JYE BAO CO.,LTD.	2017/4/21	2018/4/20
ETSTW-Cable 022	N TYPE Cable	5006	0002	JYE BAO CO.,LTD.	2017/4/6	2018/4/5
ETSTW-Cable 026	Microwave Cable	SUCOFLEX 104	279075	HUBER+SUHNER	2017/3/1	2018/2/28
ETSTW-Cable 027	Microwave Cable	SUCOFLEX 104	279083	HUBER+SUHNER	2017/5/3	2018/5/2
ETSTW-Cable 028	Microwave Cable	FA147A0015M2020	30064-2	UTIFLEX	2016/9/20	2017/9/19
ETSTW-Cable 029	Microwave Cable	FA147A0015M2020	30064-3	UTIFLEX	2016/9/20	2017/9/19
ETSTW-Cable 030	Microwave Cable	SUCOFLEX 104 (S Cable 9)	279067	HUBER+SUHNER	2017/3/1	2018/2/28
ETSTW-Cable 031	Microwave Cable	SUCOFLEX 104 (S Cable 10)	238092	HUBER+SUHNER	2017/4/12	2018/4/11
ETSTW-Cable 043	Microwave Cable	SUCOFLEX 104	317576	HUBER+SUHNER	2017/4/12	2018/4/11
ETSTW-Cable 048	Microwave Cable	SUCOFLEX 104	325519	HUBER+SUHNER	2017/4/12	2018/4/11



Worldwide Testing Services(Taiwan) Co., Ltd.

Report Number: W6M21703-16710-P-2224

FCC ID: 2ALG8RMBU3GTR

ETSTW-Cable 058	Microwave Cable	SUCOFLEX 104	none	HUBER+SUHNER	2017/2/20	2018/2/19
ETSTW-Cable 064	Microwave Cable	SUCOFLEX 104	MY28891	HUBER+SUHNER	2017/4/12	2018/4/11
ETSTW-Cable 066	SMA type cable	32022	None	ASTROLAB	2016/9/12	2017/9/11
ETSTW-Cable 071	N TYPE CABLE	EMCCFD400-NM- NM-25000	170239	EMCI	2017/2/20	2018/2/19
WTSTW-SW 002	EMI TEST SOFTWARE	EZ EMC	None	Farad	Version ETS-03A1	
WTSTW-SW 006	EMI TEST SOFTWARE	e3	None	AUDIX	Version 9.161014	
WTSTW-SW 008	Signal studio	Agilent	None	AUDIX	Version 2.0.0.1	

Report Number: W6M21703-16710-P-2224

FCC ID: 2ALG8RMBU3GTR

3. RF Power Output

3.1 Test procedure

3.1.1 Conducted Method

Per 47CFR Part 2.1046, the RF power output shall be measured at the RF output terminals and following procedure is employed:

The transmitter output was connected as the following figure:

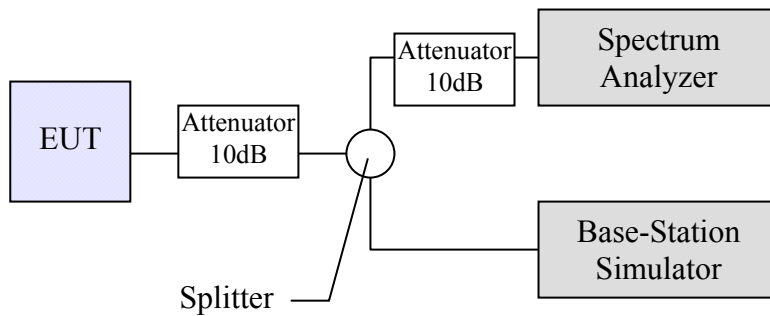

The whole connection system is calibrated with a standard signal generator. Power on and make a link form simulator to EUT and then set the EUT to maximum output power.

Measure the RF power with the spectrum analyzer in accordance the following settings:

RBW: 300 kHz for Frequency below 1GHz and 1MHz for Frequency equal to and above 1GHz.

VBW: 300 kHz for Frequency below 1GHz and 1MHz for Frequency equal to and above 1GHz.

Span: 2MHz

Sweep: 3s

The power output at the transmitter antenna terminal is then determined by assign the value of the corrected factor to the spectrum analyzer reading.

Tests were performed at three frequencies (low, middle and high channels) and operation mode selected.

Report Number: W6M21703-16710-P-2224
 FCC ID: 2ALG8RMBU3GTR

3.1.2 Radiated Method

If the conducted measurement is not practical due to the integral antenna, the radiated measurement will be performed in accordance the following procedure:

The EUT was positioned on a non-conductive turntable, 0.8m above the ground on an open test site.

The radiated emission at the fundamental frequency was measured at 3m distance with a test antenna and spectrum analyzer.

Worst case emission was recorded with the rotation of the turntable and the raising and lowering of the test antenna.

Substitution RF power Measurement at WTS Taiwan
 General:

The applied substitution method follows ANSI/TIA/EIA-603,ANSI/TIA/EIA-102.CAAA or the appropriate ETSI rules respectively.

The actual signal generated by the EUT can be determined by means of a substitution measurement in which a known signal source replaces the device to be measured.

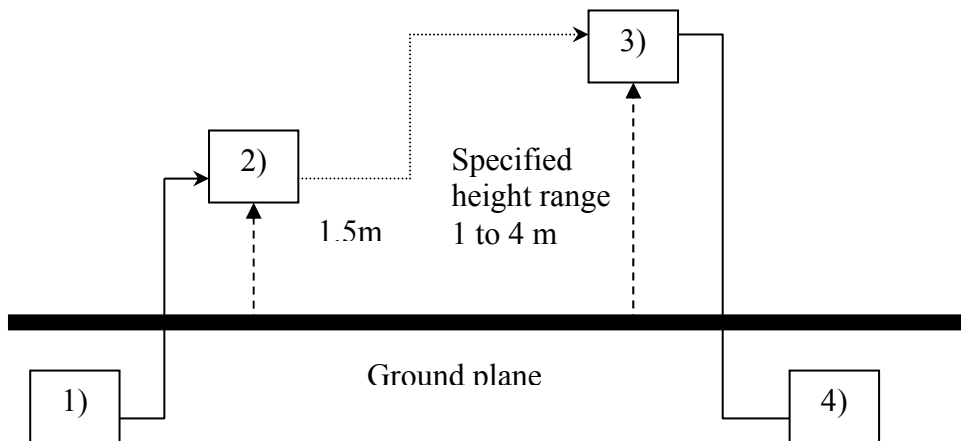

- 1) Signal generator;
- 2) Substitution antenna;
- 3) Test antenna;
- 4) Spectrum analyzer or selective voltmeter.

The substitution antenna replaces the transmitter antenna at the same position and in vertical polarization. The frequency of the signal generator shall be adjusted to the measurement frequency.



Report Number: W6M21703-16710-P-2224

FCC ID: 2ALG8RMBU3GTR

The test antenna shall be raised or lowered, if necessary, to ensure that the maximum signal is still received. The input signal to the substitution antenna shall be adjusted in level until an equal or a known related level to that detected from the transmitter is obtained in the measurement receiver.

If a fully anechoic chamber is used as test site in order to provide free space conditions there is no need to change the height of the antenna.

The measurement will be repeated in horizontal position.

Calibration:

In order to make this kind of measurement more effective and to avoid subjective measurement faults ETS has installed automatic computer controlled measurement procedures.

With the above described substitution method a test site is calibrated over the full frequency range which is used in suitable frequency steps. For a certain power level on the substitution antenna the received power over the whole frequency range is documented. All necessary antenna gains, cable losses, filter losses and amplifications of preamplifiers are taken in

consideration. The summary of this calibration measurement performs a transducer factor that is related to the considered test site and a certain measurement distance. Differences of the radiated power levels of different test samples are determined by internal attenuation of measurement receiver. The proper function of such test site will be maintained by short term plausibility checks and periodical re-calibration.

Testing:

The test sample will be putted on the table at the defined position and the radiated power will be receiver and documented by the measurement receiver.

On test sites with ground plane the measurement antenna will be lowered and raised to maximum values at significant frequencies.

For peak power measurements the sample is turned by the turntable over 360 degree in order to find the direction with the maximum radiation or to document the max reading with the MAXHOLD function during the rotation.



Report Number: W6M21703-16710-P-2224

FCC ID: 2ALG8RMBU3GTR

3.2 Test Results

- Conducted Measurement
 - Radiated Measurement
- Band 850 MHz
4.07 V

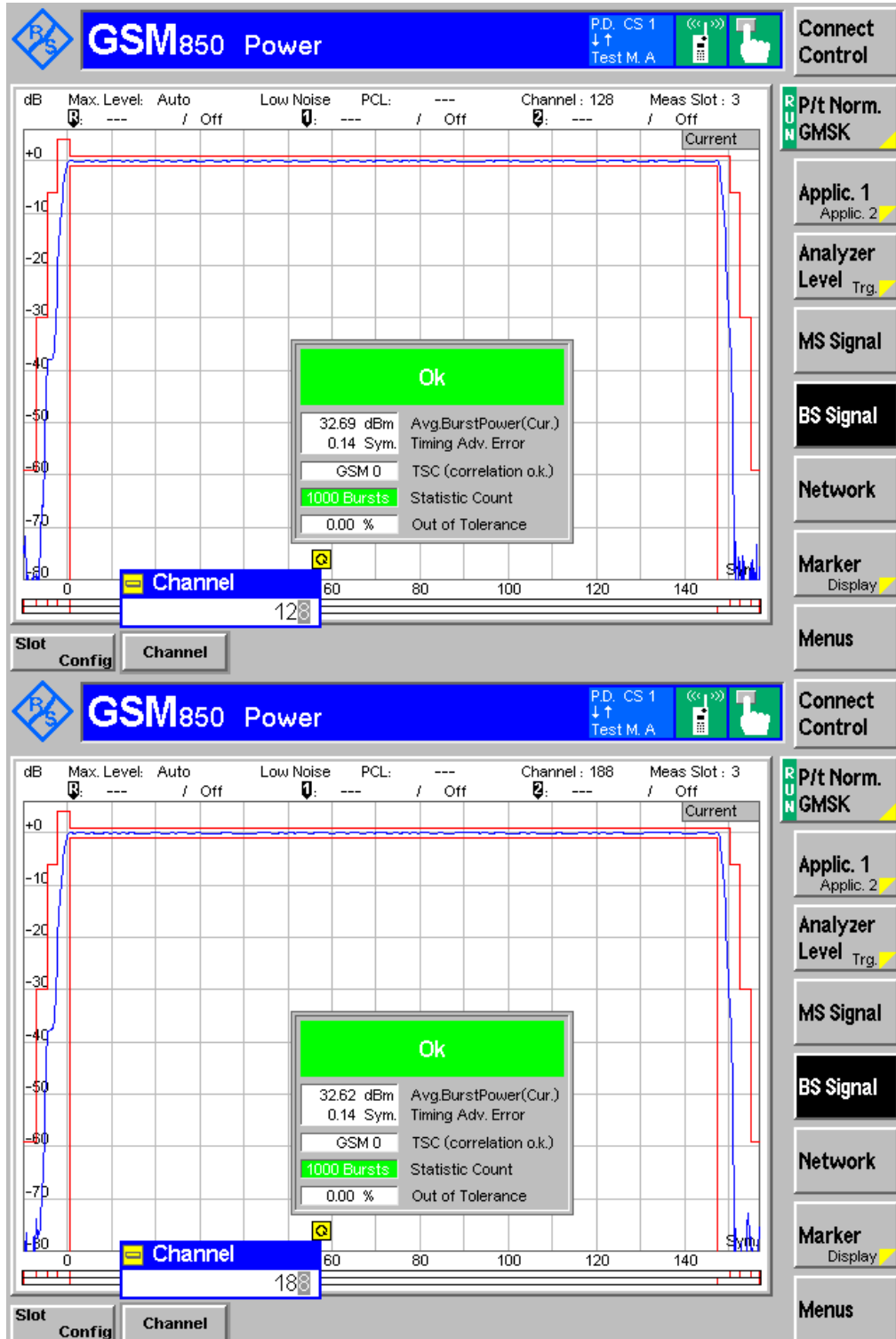

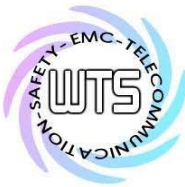

Report Number: W6M21703-16710-P-2224
FCC ID: 2ALG8RMBU3GTR

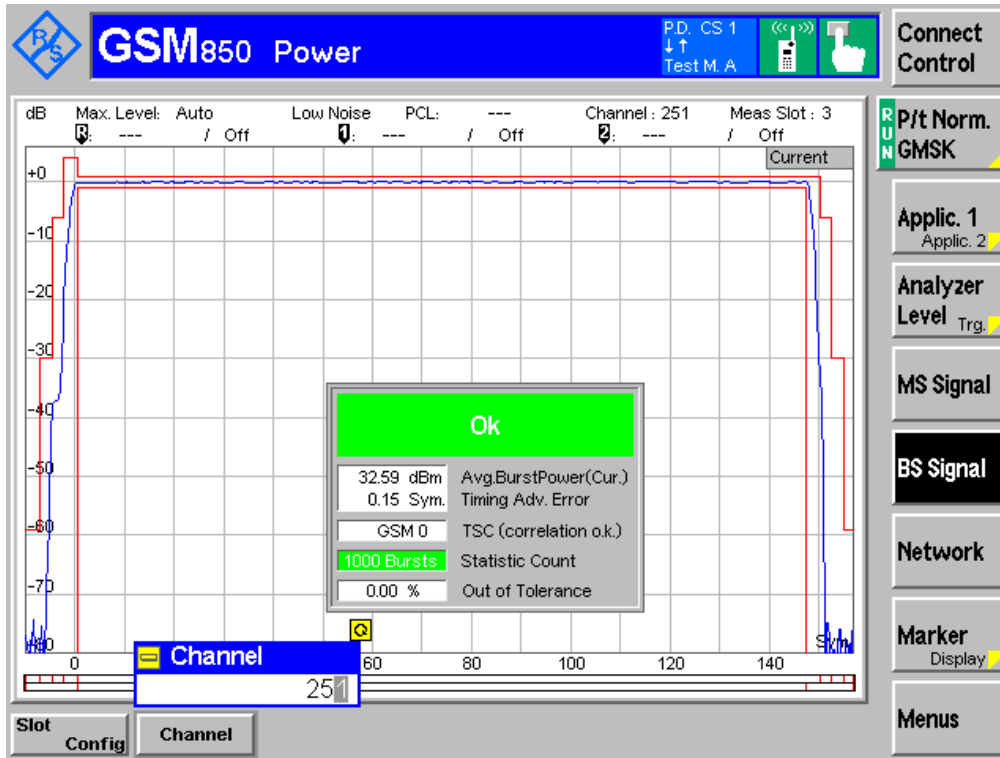

3.33 V

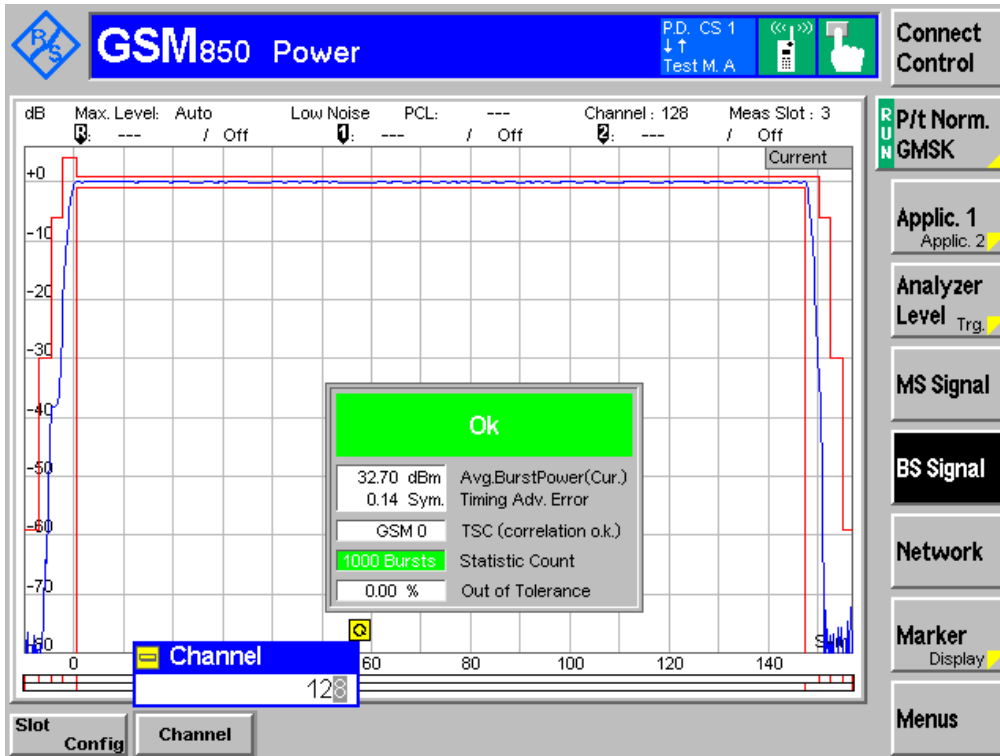

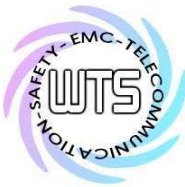

Report Number: W6M21703-16710-P-2224
FCC ID: 2ALG8RMBU3GTR

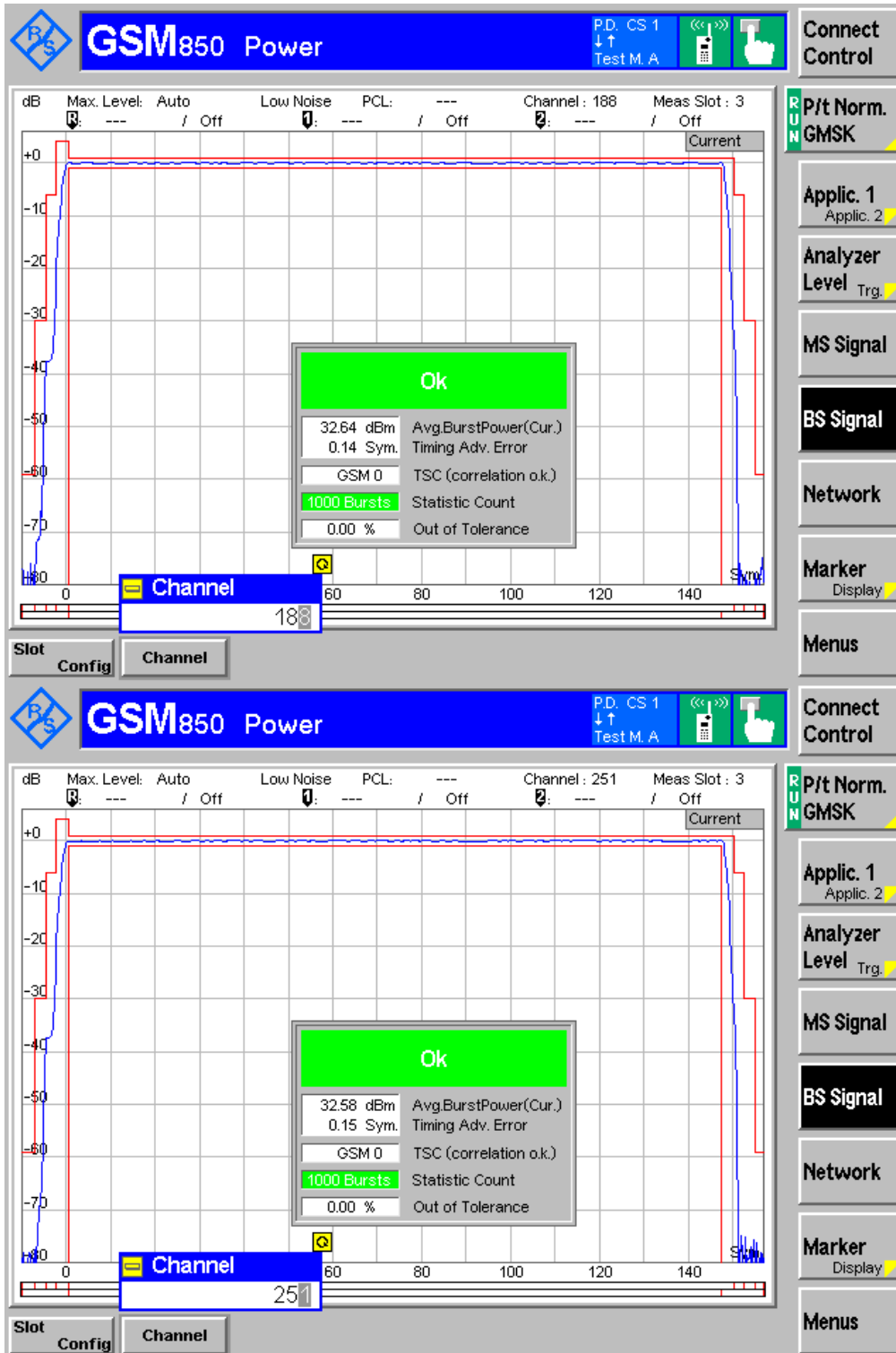



Worldwide Testing Services(Taiwan) Co., Ltd.

Report Number: W6M21703-16710-P-2224

FCC ID: 2ALG8RMBU3GTR

Band 1900 MHz

4.07 V

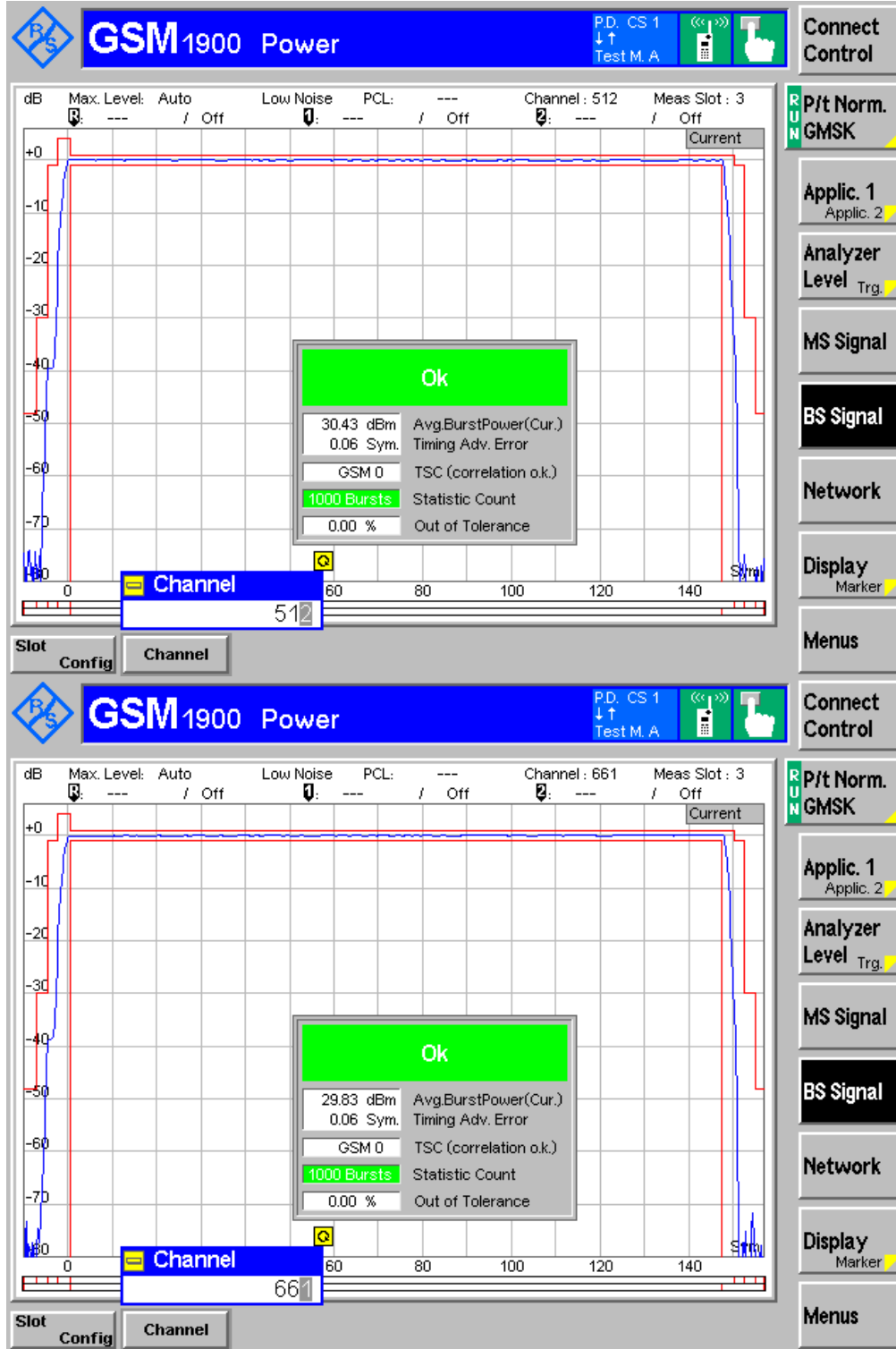

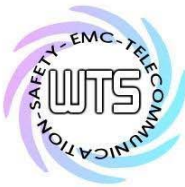

Report Number: W6M21703-16710-P-2224
FCC ID: 2ALG8RMBU3GTR

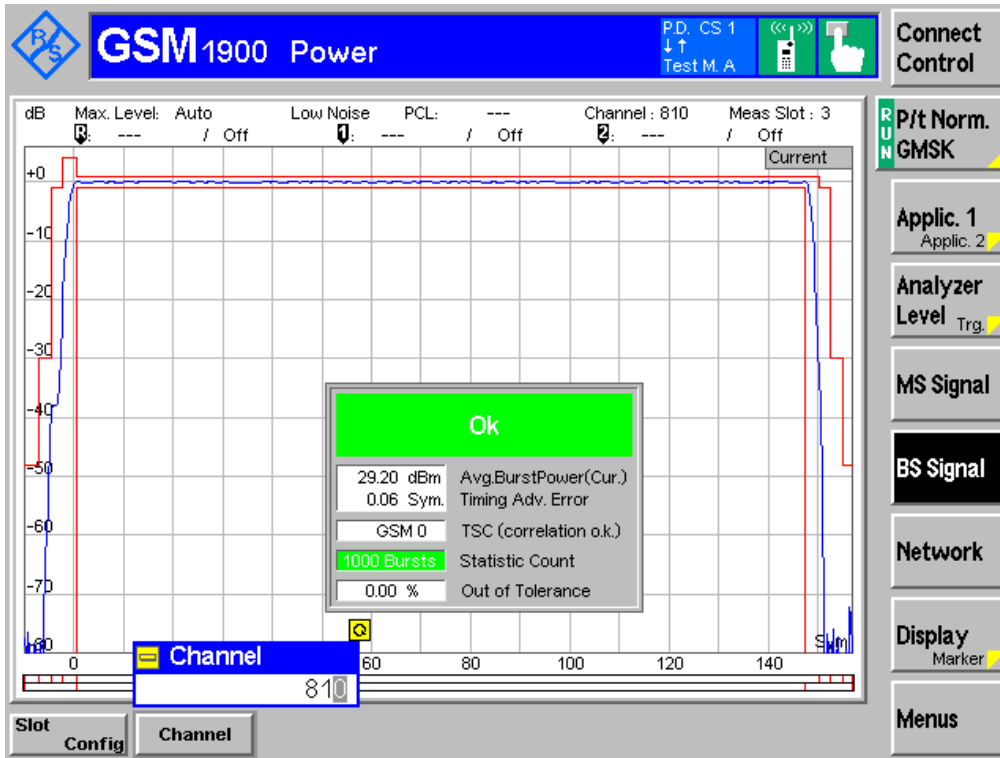

3.33 V

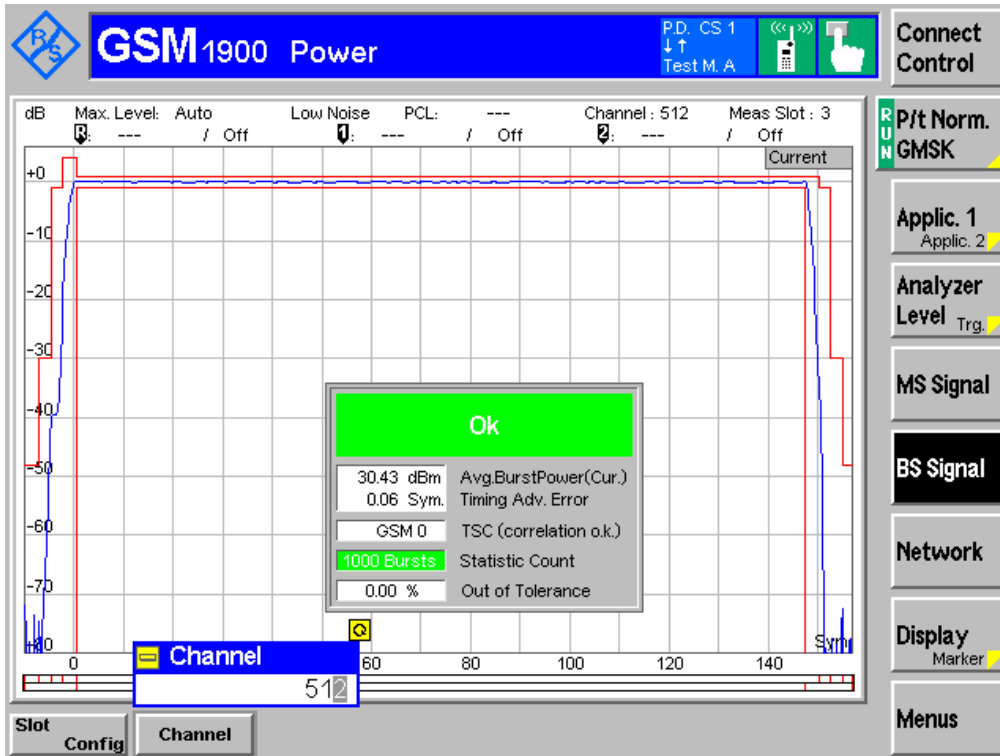

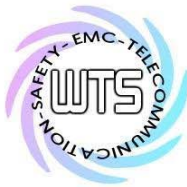

Report Number: W6M21703-16710-P-2224
FCC ID: 2ALG8RMBU3GTR

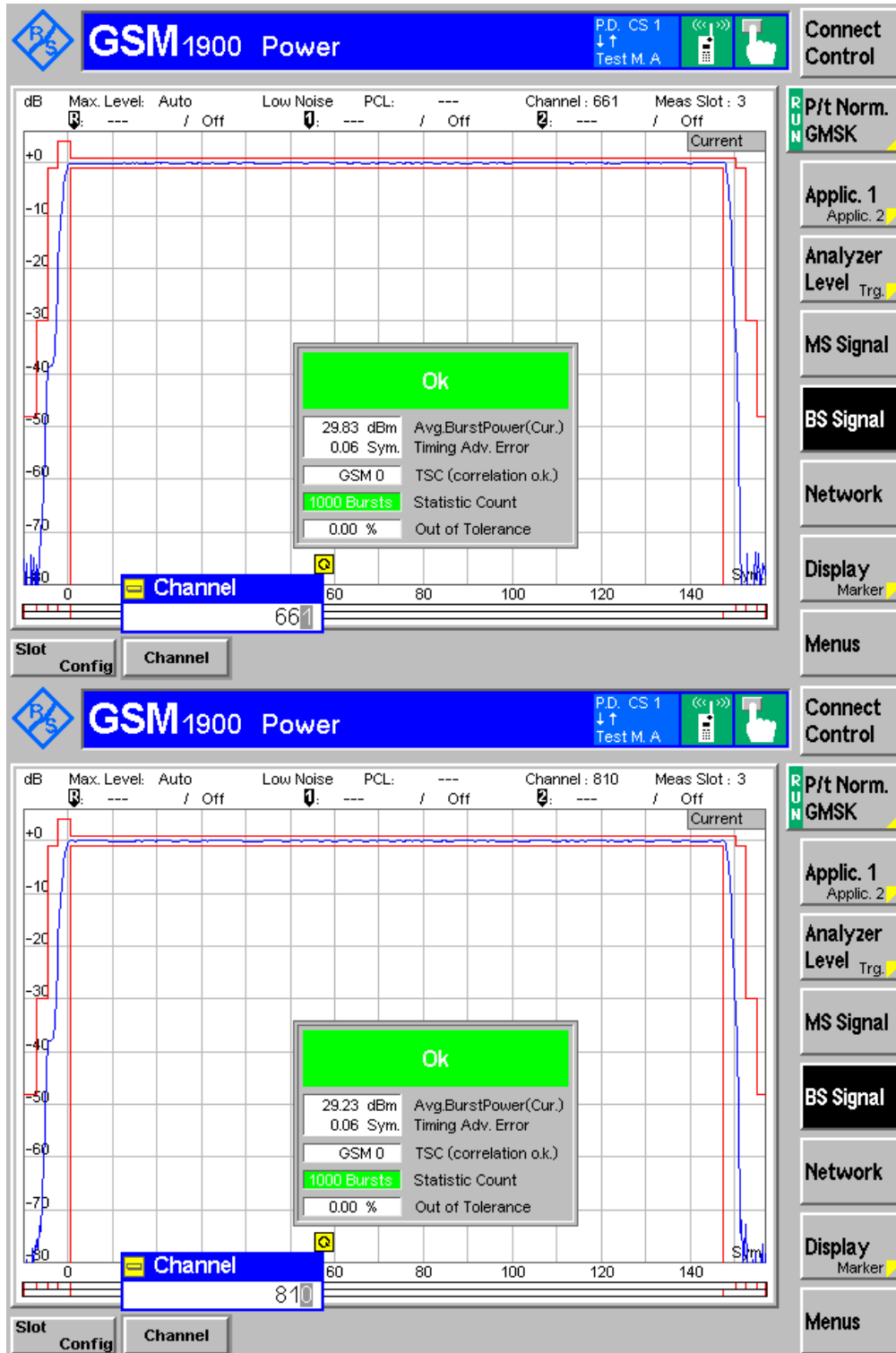

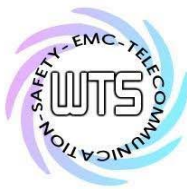

Worldwide Testing Services(Taiwan) Co., Ltd.

Report Number: W6M21703-16710-P-2224

FCC ID: 2ALG8RMBU3GTR

Band II

4.07 V

WCDMA FDD Band II Power (Channel 926)

Max.Level: Auto Low noise Freq.Offset: + 0.000 kHz Chan./Freq.: 9262 /1852.4 MHz

	Current	Average	Maximum	Minimum
UE Power (Peak)	24.60 dBm	24.61 dBm	24.82 dBm	20.41 dBm
UE Power (RMS)	21.33 dBm	21.36 dBm	21.46 dBm	20.41 dBm

Statistic Count: 1000
100.00 % Out of Tolerance

RF Channel: 926

RF Channel | RF Frequency | RF Freq. Offset | Release 5 Guard Per.

WCDMA FDD Band II Power (Channel 940)

Max.Level: Auto Low noise Freq.Offset: + 0.000 kHz Chan./Freq.: 9400 /1880.0 MHz

	Current	Average	Maximum	Minimum
UE Power (Peak)	24.46 dBm	24.50 dBm	24.77 dBm	20.14 dBm
UE Power (RMS)	21.25 dBm	21.16 dBm	21.30 dBm	20.14 dBm

Statistic Count: 1000
100.00 % Out of Tolerance

RF Channel: 940

RF Channel | RF Frequency | RF Freq. Offset | Release 5 Guard Per.



Report Number: W6M21703-16710-P-2224
 FCC ID: 2ALG8RMBU3GTR

WCDMA FDD Band II Power | CM OFF HSUPA HSDPA | Connect Control

Max.Level: Auto | Low noise | Freq.Offset: + 0.000 kHz | Chan./Freq.: 9538 /1907.6 MHz

	Current	Average	Maximum	Minimum
UE Power (Peak)	24.39 dBm	24.31 dBm	24.52 dBm	
UE Power (RMS)	21.22 dBm	21.15 dBm	21.26 dBm	20.26 dBm

1000
Statistic Count

100.00 %
Out of Tolerance

Buttons: Power, Modulation, Spectrum, Code Dom. Power, Receiver Quality, Connect Control, Maximum Power, Application, Analyzer Lev. Trigg, Ana.Set. UE Signal, HSUPA BS Sig. Lvl. HSDPA, BS Signal Settings, Menu

3.33 V

WCDMA FDD Band II Power | CM OFF HSUPA HSDPA | Connect Control

Max.Level: Auto | Low noise | Freq.Offset: + 0.000 kHz | Chan./Freq.: 9262 /1852.4 MHz

	Current	Average	Maximum	Minimum
UE Power (Peak)	24.71 dBm	24.51 dBm	24.82 dBm	
UE Power (RMS)	21.40 dBm	21.36 dBm	21.46 dBm	20.41 dBm

1000
Statistic Count

100.00 %
Out of Tolerance

RF Channel: 9262

Buttons: RF Channel, RF Frequency, RF Freq.Off set, Release 5 Guard Per., Connect Control, Maximum Power, Application, Analyzer Lev. Trigg, Ana.Set. UE Signal, HSUPA BS Sig. Lvl. HSDPA, BS Signal Settings, Menu



Report Number: W6M21703-16710-P-2224
 FCC ID: 2ALG8RMBU3GTR

WCDMA FDD Band II Power
CM OFF HSUPA HSDPA

Max.Level: Auto Low noise Freq.Offset: + 0.000 kHz Chan./Freq.: 9400 /1880.0 MHz

	Current	Average	Maximum	Minimum
UE Power (Peak)	24.41 dBm	24.49 dBm	24.73 dBm	
UE Power (RMS)	21.26 dBm	21.18 dBm	21.29 dBm	20.20 dBm

1000
 Statistic Count

100.00 %
 Out of Tolerance

RF Channel

940

RF Channel
RF Frequency
RF Freq.Offset
Release 5 Guard Per.

WCDMA FDD Band II Power
CM OFF HSUPA HSDPA

Max.Level: Auto Low noise Freq.Offset: + 0.000 kHz Chan./Freq.: 9538 /1907.6 MHz

	Current	Average	Maximum	Minimum
UE Power (Peak)	23.50 dBm	24.30 dBm	24.55 dBm	
UE Power (RMS)	20.30 dBm	21.14 dBm	21.28 dBm	20.21 dBm

1000
 Statistic Count

100.00 %
 Out of Tolerance

RF Channel

953

RF Channel
RF Frequency
RF Freq.Offset
Release 5 Guard Per.

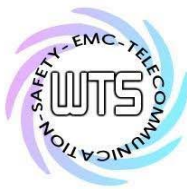

Worldwide Testing Services(Taiwan) Co., Ltd.

Report Number: W6M21703-16710-P-2224

FCC ID: 2ALG8RMBU3GTR

Band V

4.07 V

WCDMA FDD Band **V** Power
CM OFF HSPA HSDPA

Max.Level: Auto Low noise Freq.Offset: + 0.000 kHz Chan./Freq.: 4132 /826.4 MHz

	Current	Average	Maximum	Minimum
UE Power (Peak)	26.17 dBm	26.17 dBm	26.37 dBm	
UE Power (RMS)	22.80 dBm	22.75 dBm	22.86 dBm	21.85 dBm

1000
 Statistic Count

0.00 %
 Out of Tolerance

RF Channel 413

RF Channel
RF Frequency
RF Freq.Offset
Release 5 Guard Per.

WCDMA FDD Band **V** Power
CM OFF HSPA HSDPA

Max.Level: Auto Low noise Freq.Offset: + 0.000 kHz Chan./Freq.: 4183 /836.6 MHz

	Current	Average	Maximum	Minimum
UE Power (Peak)	26.49 dBm	26.46 dBm	26.81 dBm	
UE Power (RMS)	22.96 dBm	22.89 dBm	23.00 dBm	21.09 dBm

1000
 Statistic Count

0.00 %
 Out of Tolerance

RF Channel 418

RF Channel
RF Frequency
RF Freq.Offset
Release 5 Guard Per.

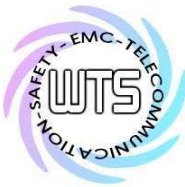

Report Number: W6M21703-16710-P-2224
 FCC ID: 2ALG8RMBU3GTR

WCDMA FDD Band v Power CM OFF HSUPA HSDPA

Max.Level: Auto Low noise Freq.Offset: + 0.000 kHz Chan./Freq.: 4233 /846.6 MHz

	Current	Average	Maximum	Minimum
UE Power (Peak)	26.00 dBm	25.98 dBm	26.20 dBm	
UE Power (RMS)	22.70 dBm	22.64 dBm	22.75 dBm	21.70 dBm

Statistic Count: 1000

Out of Tolerance: 0.00 %

RF Channel: 423.3

RF Channel RF Frequency RF Freq.Offset Release 5 Guard Per. Menus

3.33 V

WCDMA FDD Band v Power CM OFF HSUPA HSDPA

Max.Level: Auto Low noise Freq.Offset: + 0.000 kHz Chan./Freq.: 4132 /826.4 MHz

	Current	Average	Maximum	Minimum
UE Power (Peak)	26.13 dBm	26.10 dBm	26.34 dBm	
UE Power (RMS)	22.84 dBm	22.76 dBm	22.85 dBm	21.85 dBm

Statistic Count: 1000

Out of Tolerance: 0.00 %

RF Channel: 413.3

RF Channel RF Frequency RF Freq.Offset Release 5 Guard Per. Menus



Report Number: W6M21703-16710-P-2224
 FCC ID: 2ALG8RMBU3GTR

WCDMA FDD Band **V** Power
CM OFF HSUPA HSDPA

Max.Level: Auto Low noise Freq.Offset: + 0.000 kHz Chan./Freq.: 4183 /836.6 MHz

	Current	Average	Maximum	Minimum
UE Power (Peak)	26.51 dBm	26.49 dBm	26.77 dBm	
UE Power (RMS)	22.98 dBm	22.92 dBm	23.00 dBm	22.04 dBm

1000
 Statistic Count

0.00 %
 Out of Tolerance

WCDMA FDD Band **V** Power
CM OFF HSUPA HSDPA

Max.Level: Auto Low noise Freq.Offset: + 0.000 kHz Chan./Freq.: 4233 /846.6 MHz

	Current	Average	Maximum	Minimum
UE Power (Peak)	25.93 dBm	25.98 dBm	26.16 dBm	
UE Power (RMS)	22.72 dBm	22.65 dBm	22.73 dBm	21.73 dBm

1000
 Statistic Count

0.00 %
 Out of Tolerance

RF Channel

RF Frequency

RF Freq.Offset

Release 5

RF Channel

RF Frequency

RF Freq.Offset

Release 5

Connect Control

Maximum Power

Application

Trigger
 Ana. Lev.

Ana.Set.
 UE Signal

HSUPA
 BS Sig. Lvl. HSDPA

BS Signal Settings

Menus

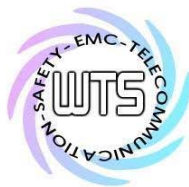

Report Number: W6M21703-16710-P-2224
 FCC ID: 2ALG8RMBU3GTR

- Conducted Measurement
- Radiated Measurement

Band 850 MHz & 1900 MHz

4.07 V

Frequency (MHz)	ERP (dBm)	EIRP (dBm)	Limit (dBm)	Result
824.1108	5.90	8.05	38.45	Pass
836.1028	10.79	12.94	38.45	Pass
837.0411	10.28	12.43	38.45	Pass
1850.135	2.42	4.57	33	Pass
1879.965	3.05	5.20	33	Pass
1909.705	2.65	4.80	33	Pass

3.33 V

Frequency (MHz)	ERP (dBm)	EIRP (dBm)	Limit (dBm)	Result
824.1068	6.30	8.45	38.45	Pass
836.2351	10.72	12.87	38.45	Pass
837.0411	10.41	12.56	38.45	Pass
1850.245	0.22	2.37	33	Pass
1879.995	0.45	2.60	33	Pass
1909.705	2.16	4.31	33	Pass

Band II & Band V

4.07 V

Frequency (MHz)	ERP (dBm)	EIRP (dBm)	Limit (dBm)	Result
1852.385	23.35	25.50	38.45	Pass
1879.384	20.60	22.75	38.45	Pass
1906.533	18.47	20.62	38.45	Pass
825.6831	15.60	17.75	33	Pass
837.5168	16.00	18.15	33	Pass
845.5330	17.16	19.31	33	Pass

3.33 V

Frequency (MHz)	ERP (dBm)	EIRP (dBm)	Limit (dBm)	Result
1851.122	23.14	25.29	38.45	Pass
1879.173	20.68	22.83	38.45	Pass
1906.563	18.53	20.68	38.45	Pass
826.5850	16.02	18.17	33	Pass
837.1261	15.91	18.06	33	Pass
845.4427	17.05	19.20	33	Pass



Worldwide Testing Services(Taiwan) Co., Ltd.

Report Number: W6M21703-16710-P-2224
FCC ID: 2ALG8RMBU3GTR

Test equipment: ETSTW-RE 004, ETSTW-RE 030, ETSTW-RE 062, ETSTW-RE 142, ETSTW-RE 147,
ETSTW-GSM 002

Note: Please refer to appendix for plot data.

Report Number: W6M21703-16710-P-2224

FCC ID: 2ALG8RMBU3GTR

4. Modulation Characteristics

4.1 Test procedure

- A curve or equivalent data showing the frequency response of the audio modulating circuit over a range of 100 to 5000 Hz shall be submitted.
The audio signal generator is connected to the audio input of the EUT with its full rating. The modulation response is measured at certain modulation frequencies, related to 1000Hz reference signal. Tests are performed for positive and negative modulation.

- Equipment which employs modulation Limiting: A curve or family of curves showing the percentage of modulation versus the modulation input voltage shall be supplied. The audio signal generator is connected to the audio input of the EUT with its full rating. The modulation limiting is measured at certain modulation frequencies from 100Hz to 15kHz.

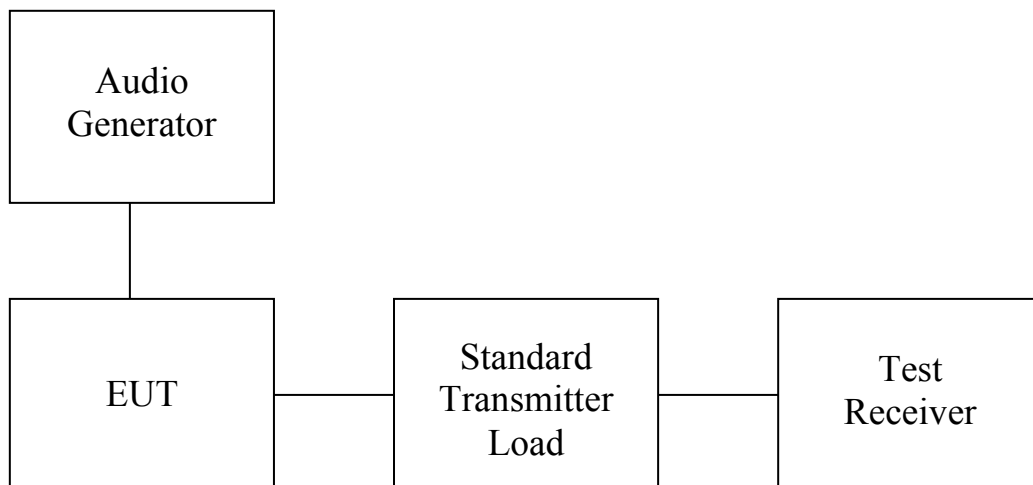

4.2 Test Results

For digital modulation employed, this test item is not applicable.

Report Number: W6M21703-16710-P-2224

FCC ID: 2ALG8RMBU3GTR

5. Occupied Bandwidth

The occupied bandwidth, that is the frequency bandwidth such that, below its lower and above its upper frequency limits, the mean powers radiated are each equal to 0.5 percent of the total mean power. Near the carrier an Emission Mask is defined by the standard.

5.1 Test procedure

The RF output of the transceiver was connected as the following figure.

Occupied Bandwidth was measured with a occupied bandwidth function of the analyzer at 99% power was occupied. Then set the spectrum analyzer to cover the upper and lower band edges to measure emission mask.

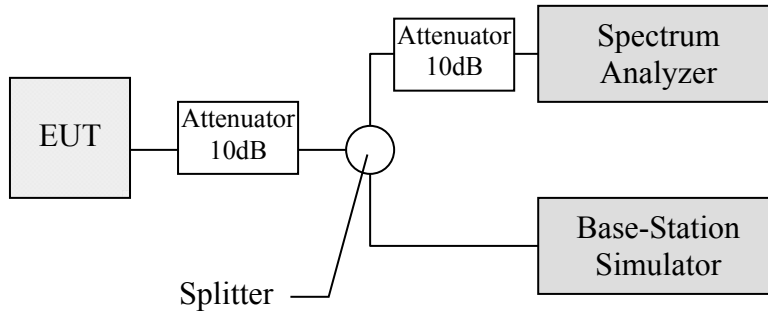

5.2 Test Results

Occupied Channel Bandwidth

Band 850 MHz

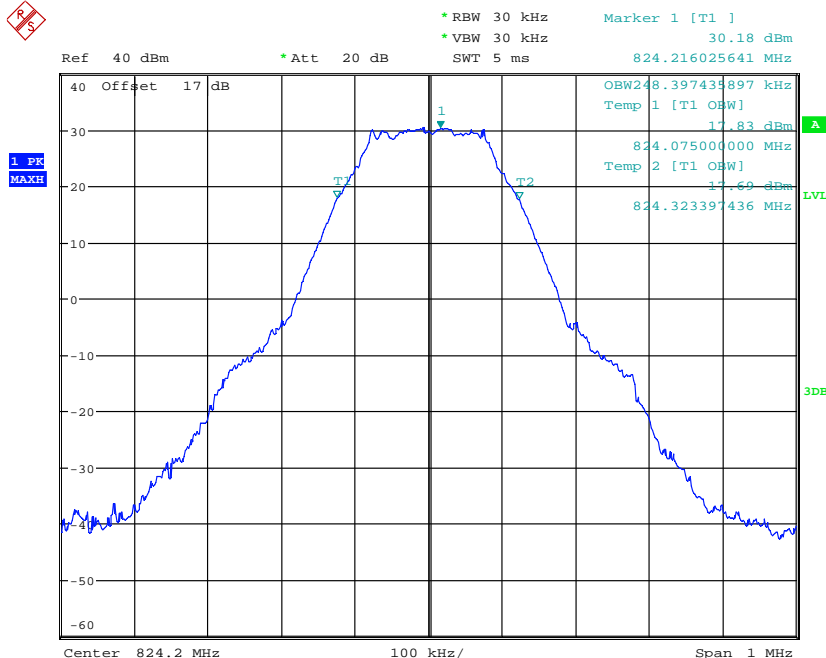

OCCUPIED BANDWIDTH GSM850 CH128

Date: 18.APR.2017 15:18:30



Report Number: W6M21703-16710-P-2224
 FCC ID: 2ALG8RMBU3GTR

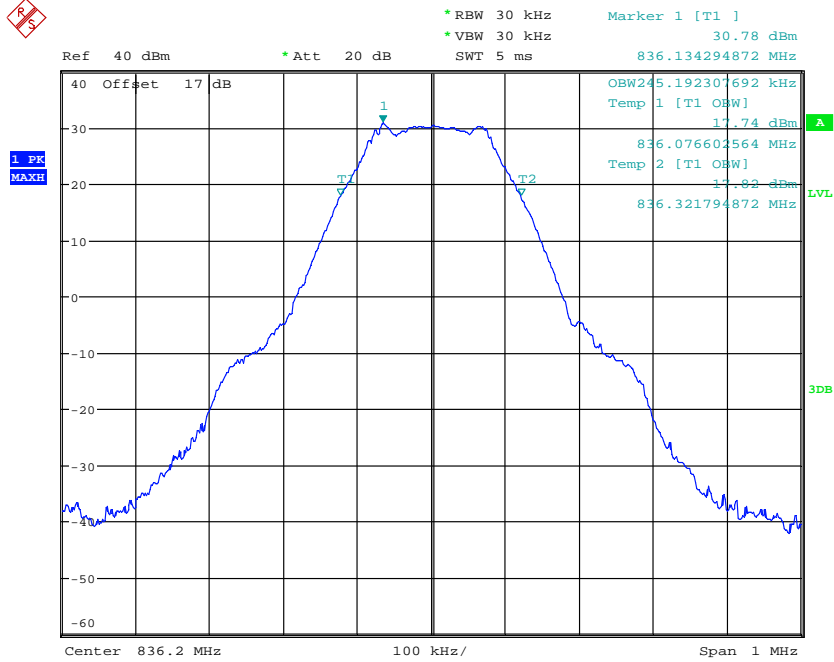

OCCUPIED BANDWIDTH GSM850 CH188
 Date: 18.APR.2017 15:20:24

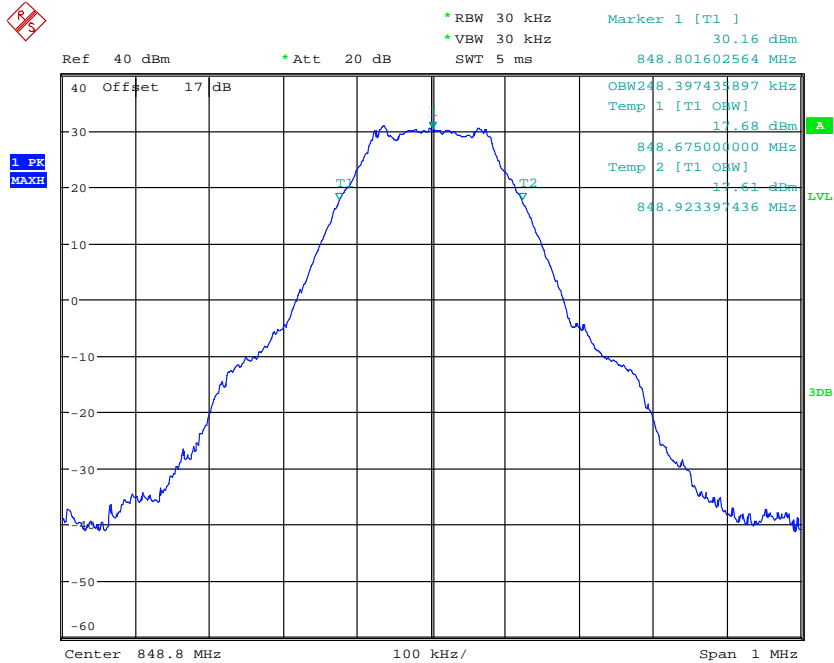

OCCUPIED BANDWIDTH GSM850 CH251
 Date: 18.APR.2017 15:21:40



Report Number: W6M21703-16710-P-2224
 FCC ID: 2ALG8RMBU3GTR
 Band 1900 MHz

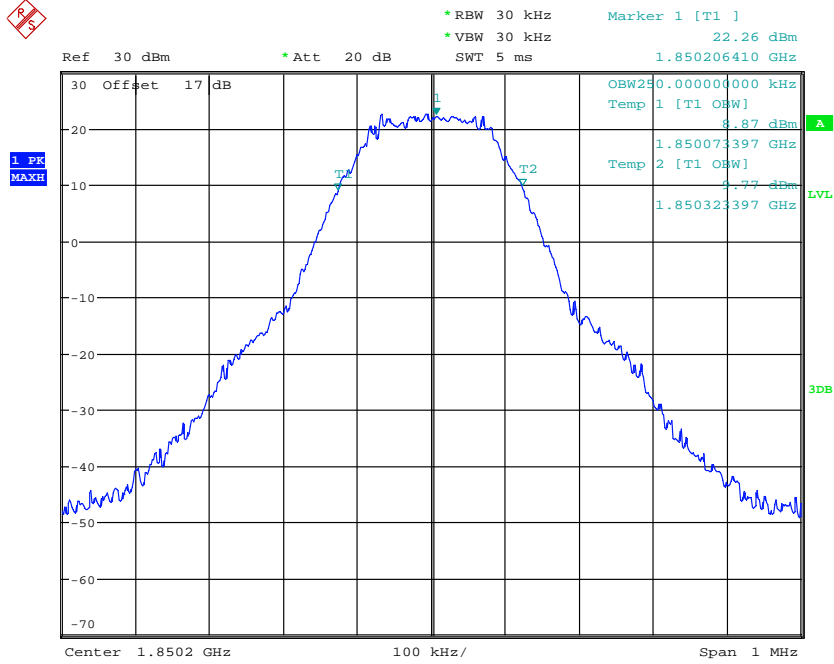

OCCUPIED BANDWIDTH DCS1900 CH512
 Date: 18.APR.2017 15:10:44

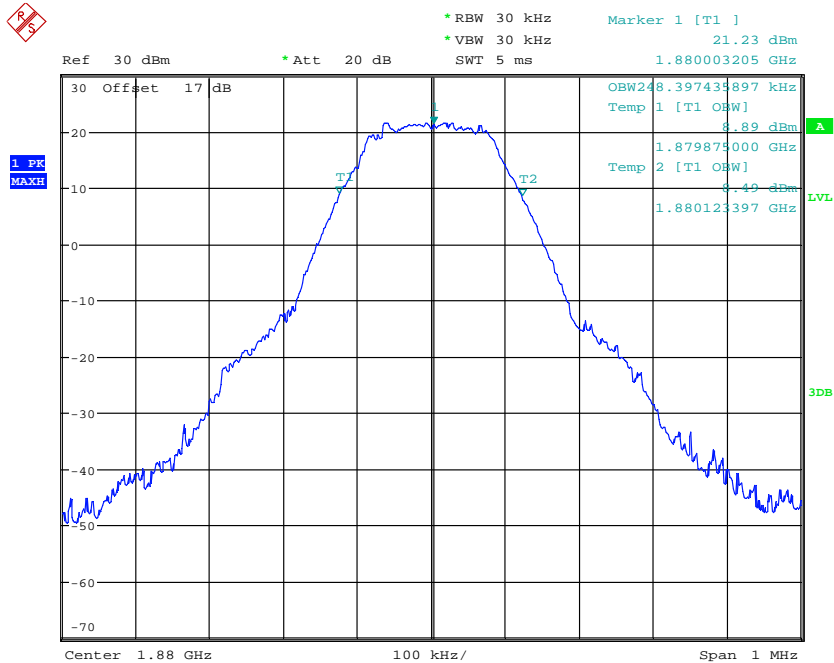

OCCUPIED BANDWIDTH DCS1900 CH661
 Date: 18.APR.2017 15:09:59



Report Number: W6M21703-16710-P-2224
 FCC ID: 2ALG8RMBU3GTR

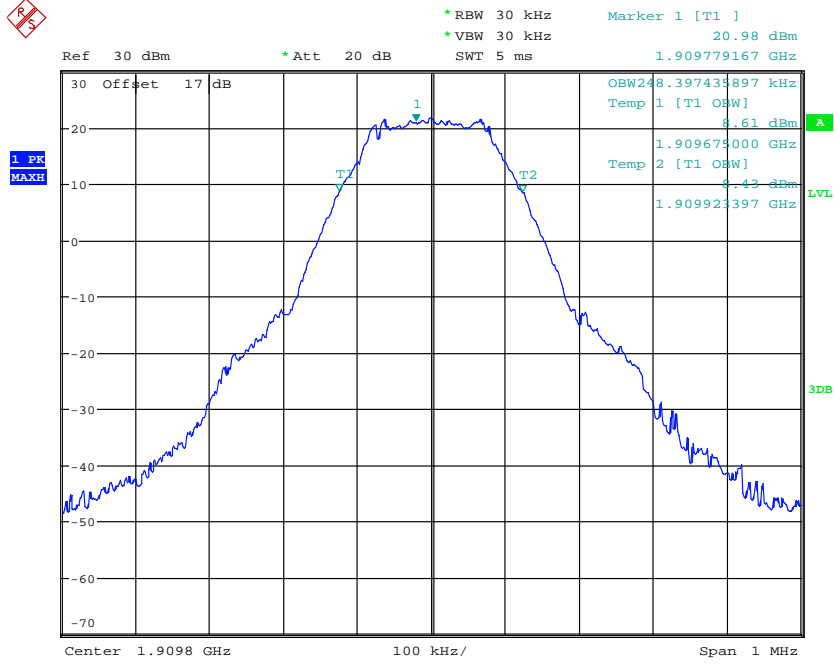

OCCUPIED BANDWIDTH DCS1900 CH810
 Date: 18.APR.2017 15:09:20

Band II

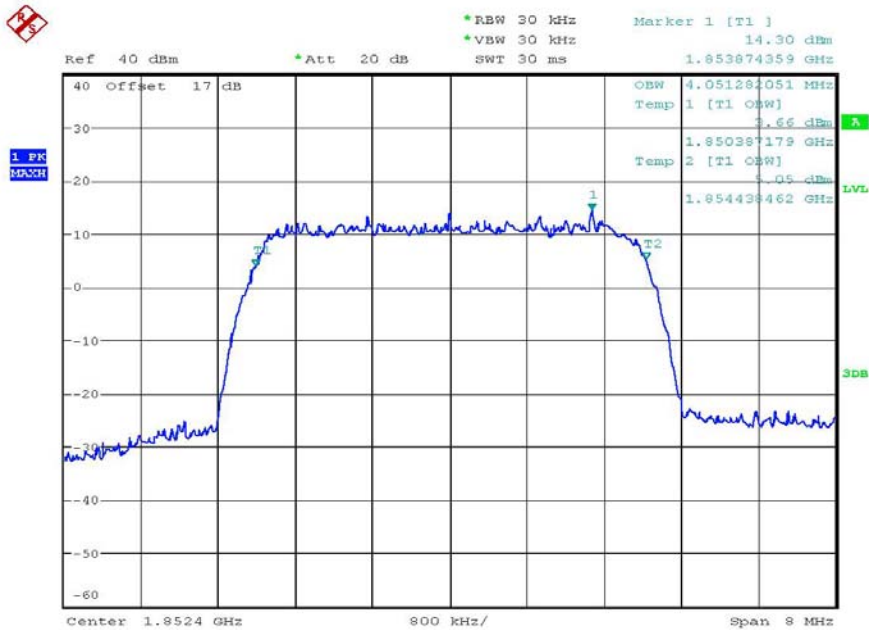

OCCUPIED BANDWIDTH WCDMA BANDII CH9262
 Date: 22.APR.2017 09:45:45



Worldwide Testing Services(Taiwan) Co., Ltd.

Report Number: W6M21703-16710-P-2224
FCC ID: 2ALG8RMBU3GTR

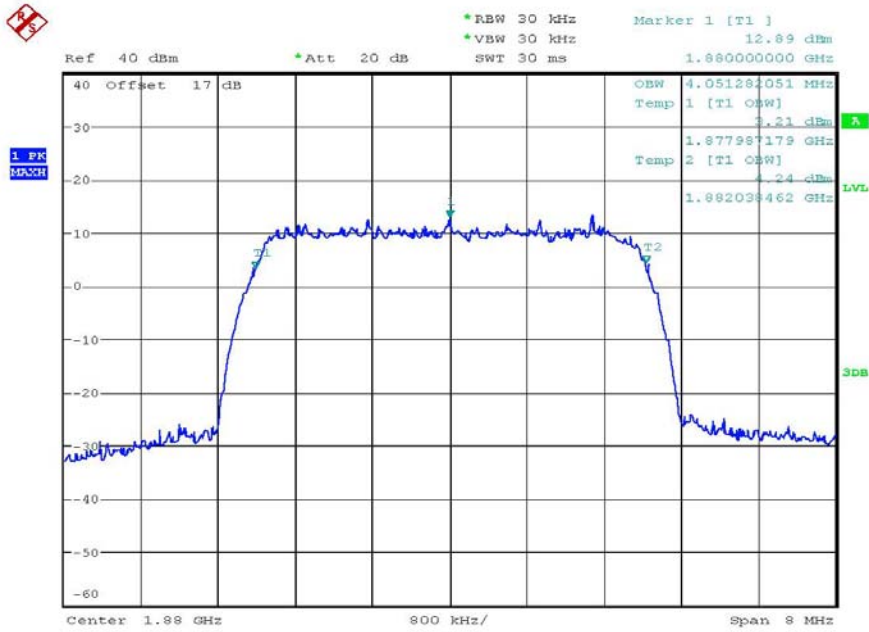

OCCUPIED BANDWIDTH WCDMA BANDII CH9400
Date: 22.APR.2017 09:46:15

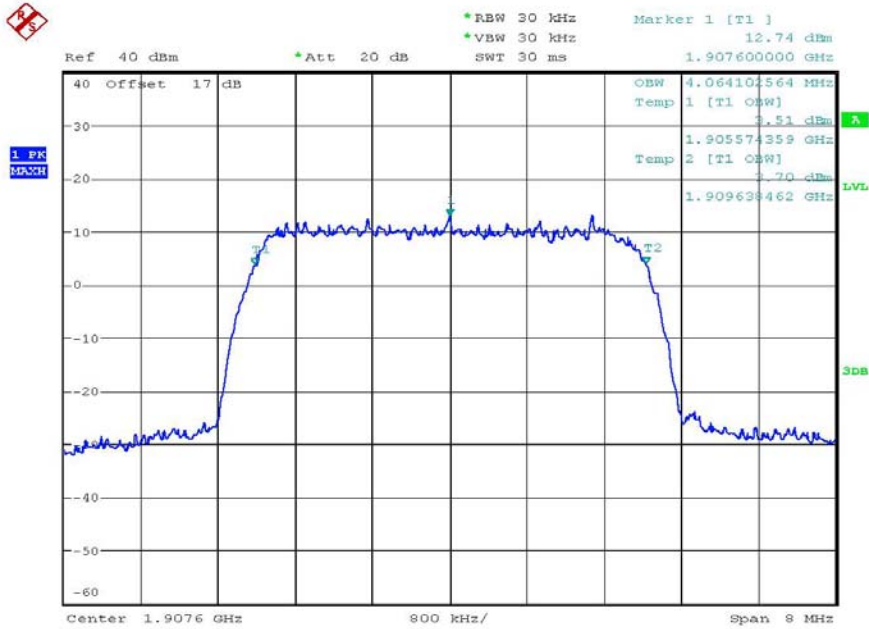

OCCUPIED BANDWIDTH WCDMA BANDII CH9538
Date: 22.APR.2017 09:47:28



Report Number: W6M21703-16710-P-2224
 FCC ID: 2ALG8RMBU3GTR
 Band V

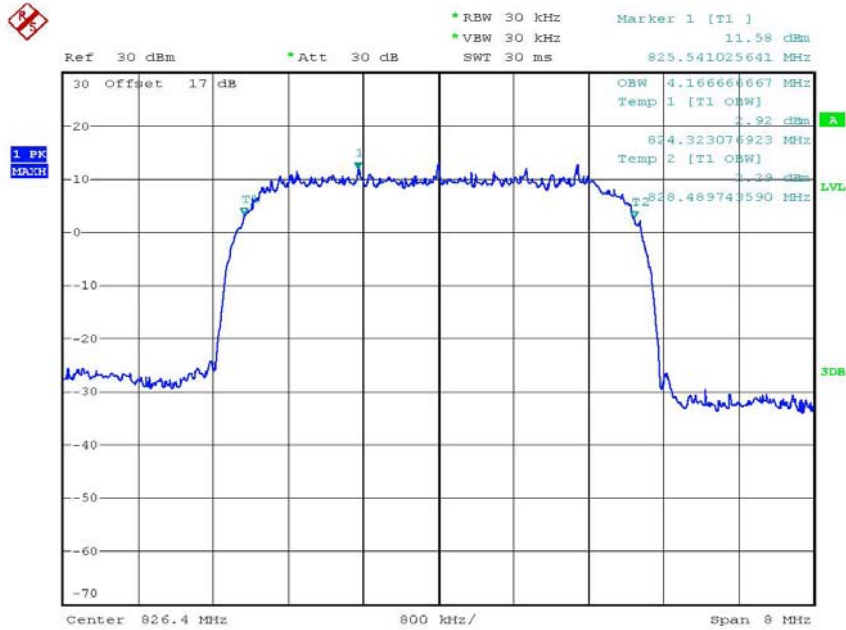

OCCUPIED BANDWIDTH WCDMA BAND V CH4132
 Date: 22.APR.2017 18:00:10

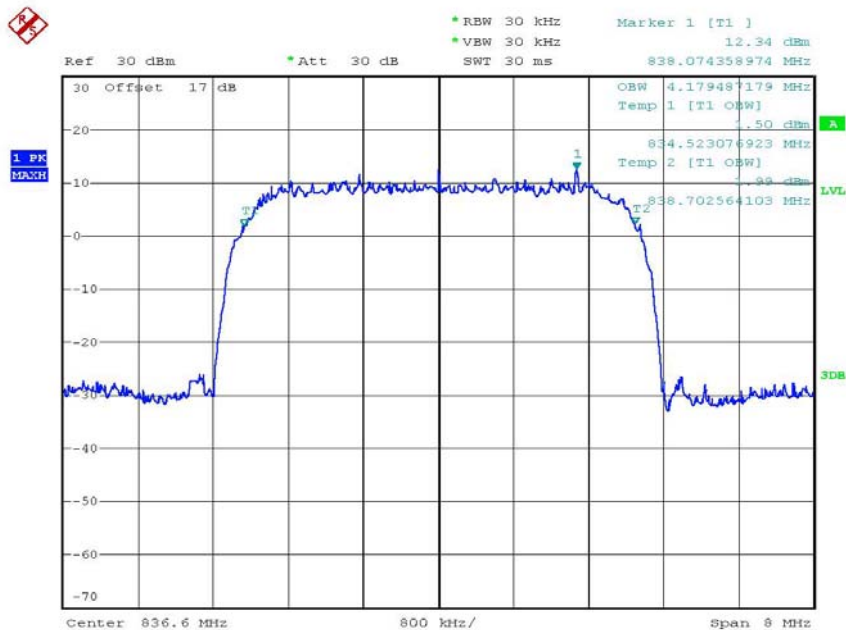

OCCUPIED BANDWIDTH WCDMA BAND V CH4183
 Date: 22.APR.2017 18:00:50



Report Number: W6M21703-16710-P-2224
 FCC ID: 2ALG8RMBU3GTR

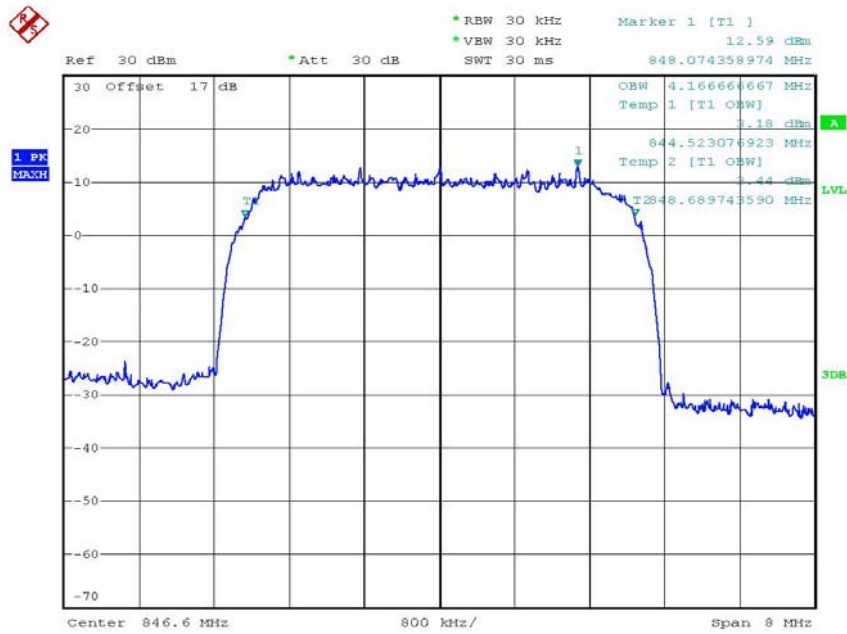

OCCUPIED BANDWIDTH WCDMA BAND V CH4233
 Date: 22.APR.2017 17:58:17

26dB Channel Bandwidth Band 850 MHz

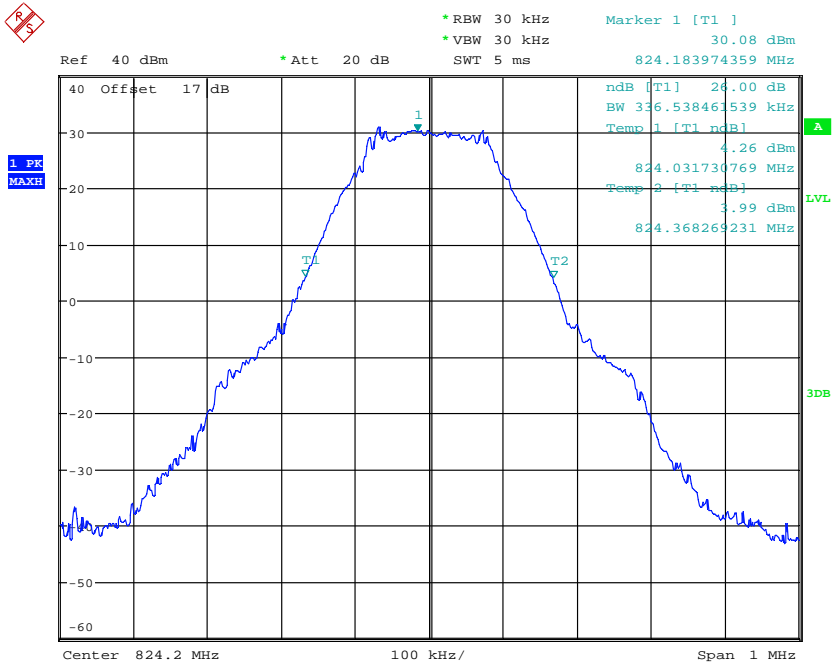

26DB BANDWIDTH GSM850 CH128
 Date: 18.APR.2017 15:24:49

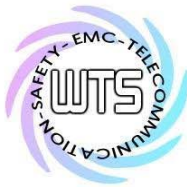

Report Number: W6M21703-16710-P-2224
FCC ID: 2ALG8RMBU3GTR

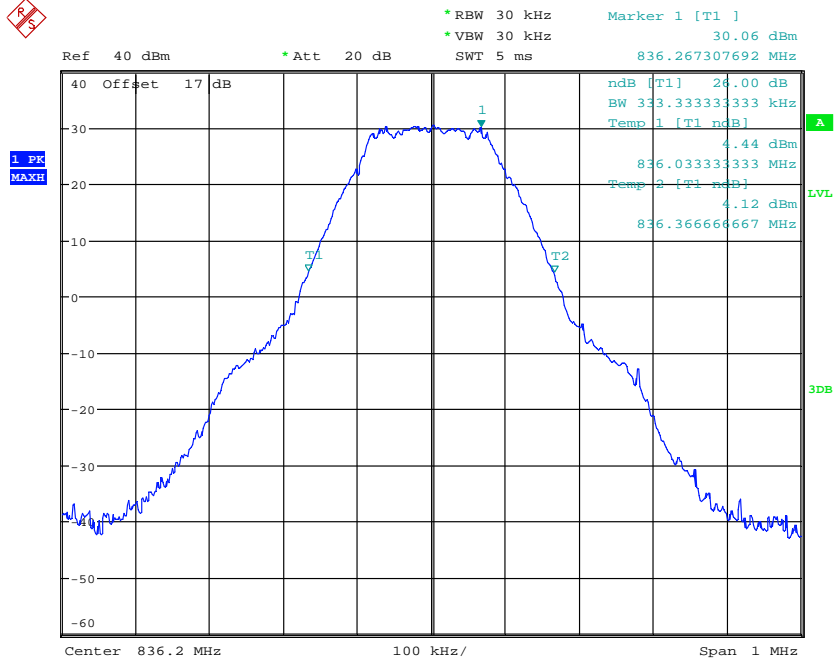

26DB BANDWIDTH GSM850 CH188
Date: 18.APR.2017 15:24:12

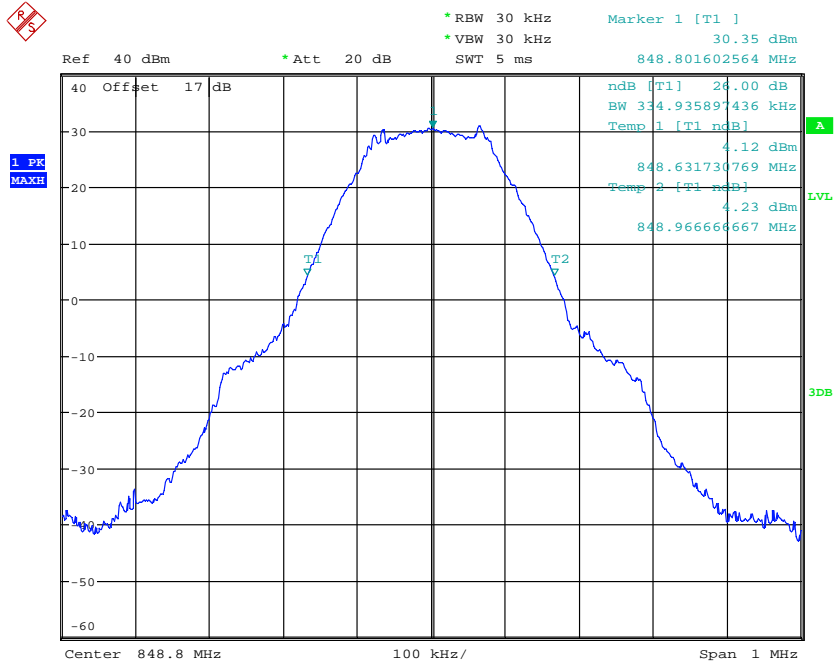

26DB BANDWIDTH GSM850 CH251
Date: 18.APR.2017 15:22:17



Report Number: W6M21703-16710-P-2224

FCC ID: 2ALG8RMBU3GTR

Band 1900 MHz

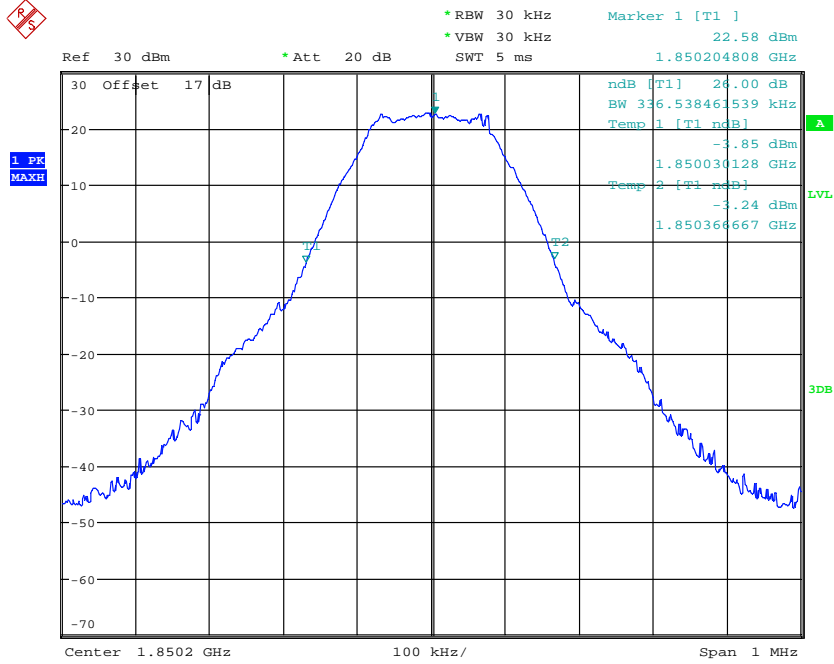

26DB BANDWIDTH DCS1900 CH512

Date: 18.APR.2017 15:06:44

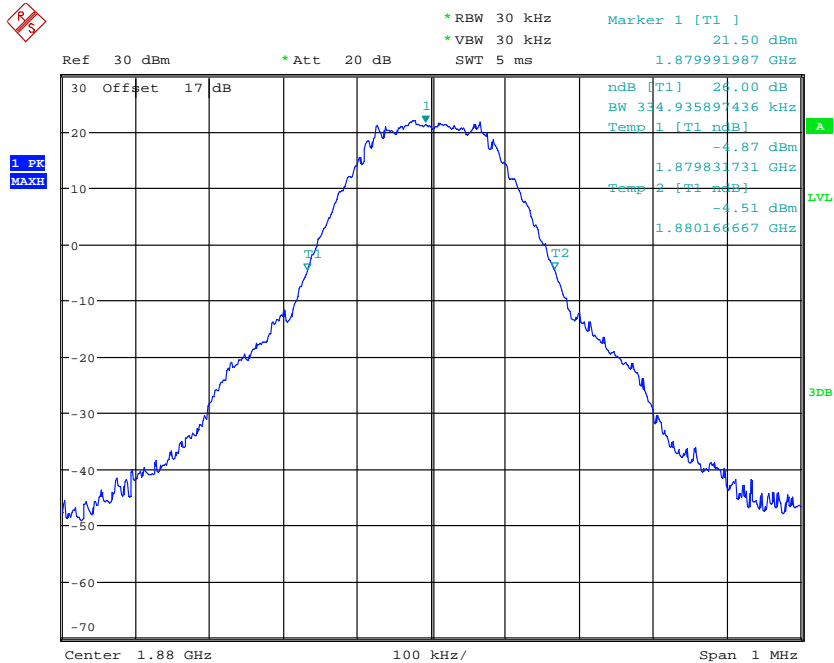

26DB BANDWIDTH DCS1900 CH661

Date: 18.APR.2017 15:07:13

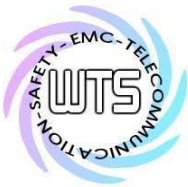

Report Number: W6M21703-16710-P-2224
 FCC ID: 2ALG8RMBU3GTR

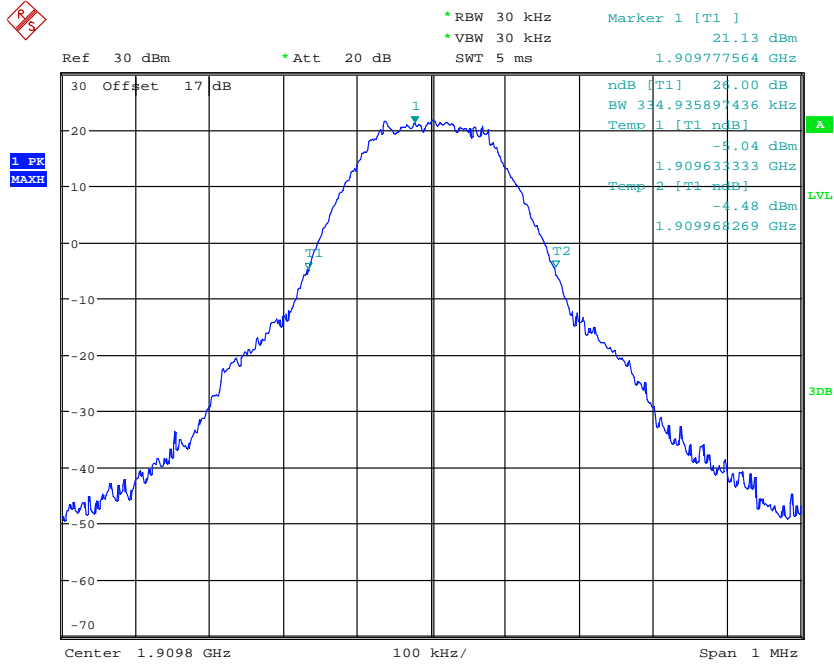

26DB BANDWIDTH DCS1900 CH810
 Date: 18.APR.2017 15:07:50

Band II

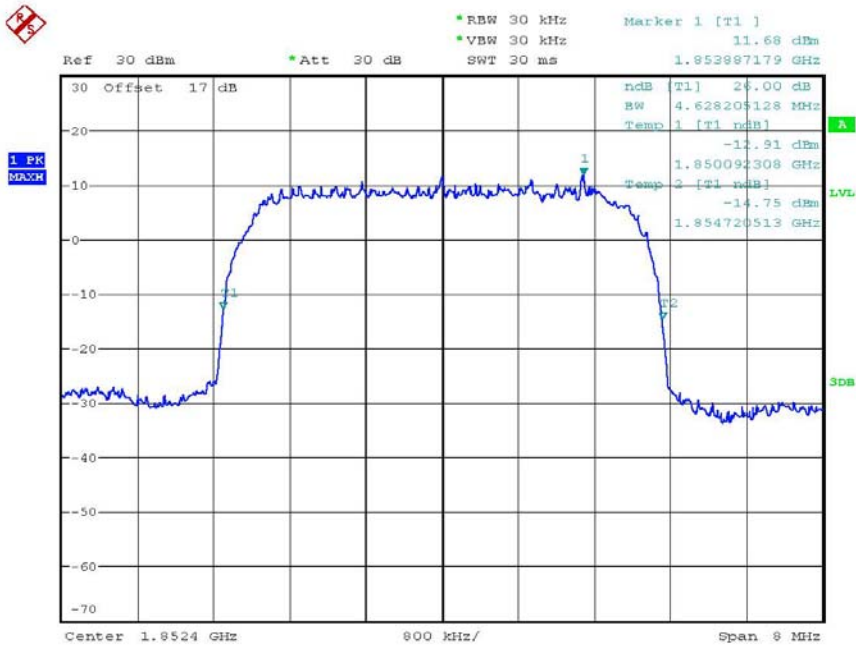

26DB BANDWIDTH WCDMA BAND 2 CH9262
 Date: 22.APR.2017 16:32:51

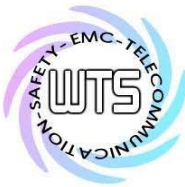

Worldwide Testing Services(Taiwan) Co., Ltd.

Report Number: W6M21703-16710-P-2224
 FCC ID: 2ALG8RMBU3GTR

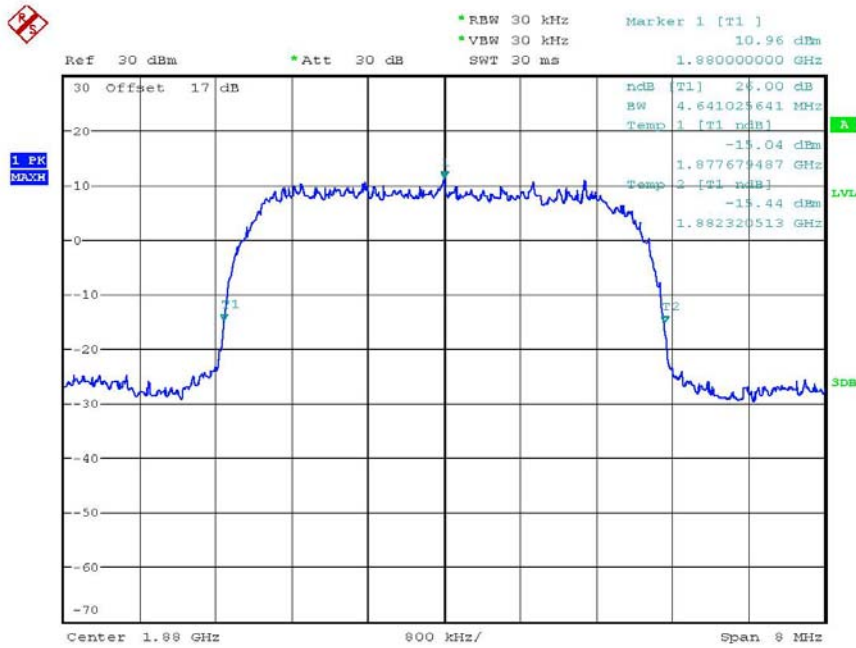

26DB BANDWIDTH WCDMA BAND 2 CH9400
 Date: 22.APR.2017 16:33:42

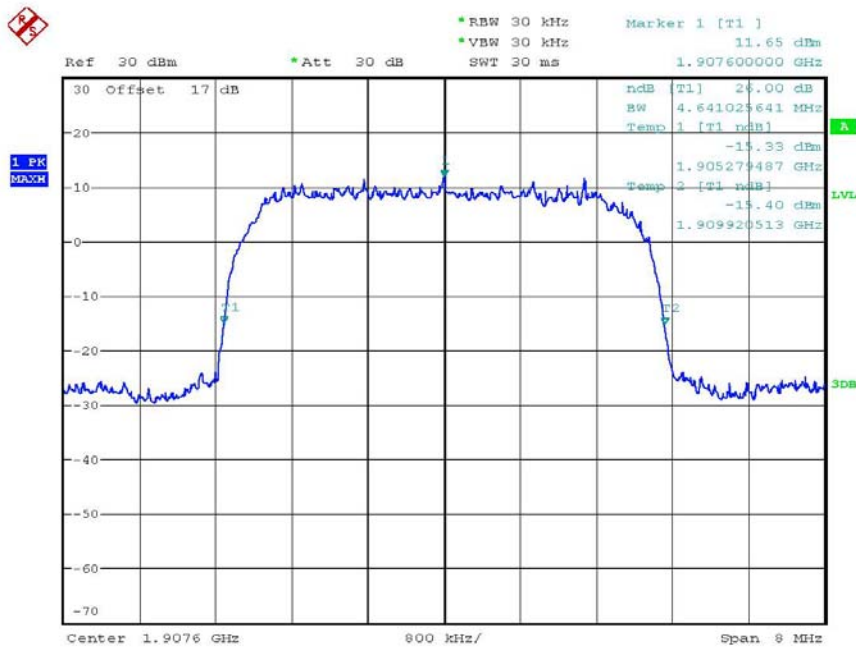

26DB BANDWIDTH WCDMA BAND 2 CH9538
 Date: 22.APR.2017 16:34:35



Worldwide Testing Services(Taiwan) Co., Ltd.

Report Number: W6M21703-16710-P-2224
FCC ID: 2ALG8RMBU3GTR
Band V

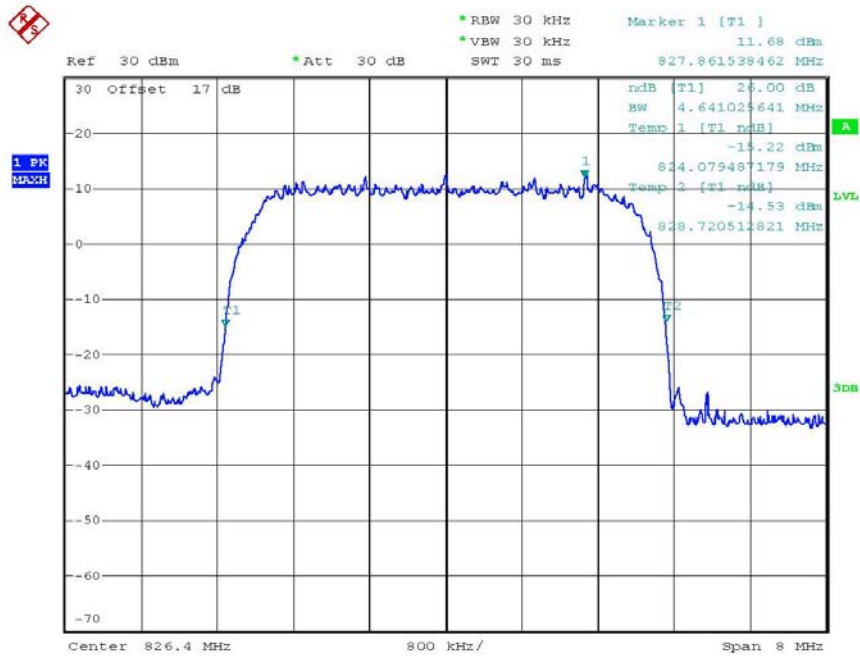

26DB BANDWIDTH WCDMA BAND V CH4132
Date: 22.APR.2017 16:30:50

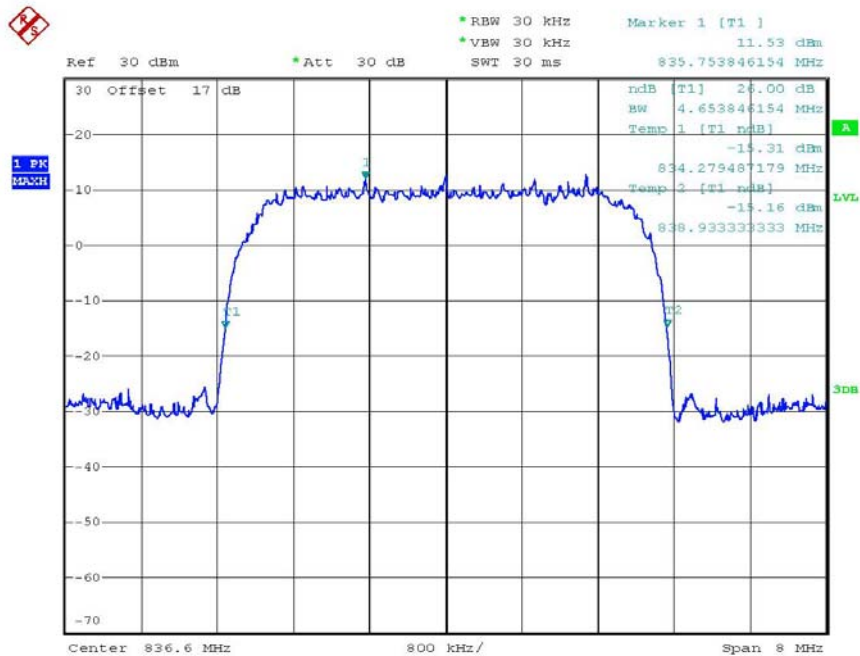

26DB BANDWIDTH WCDMA BAND V CH4183
Date: 22.APR.2017 16:29:54



Report Number: W6M21703-16710-P-2224
FCC ID: 2ALG8RMBU3GTR

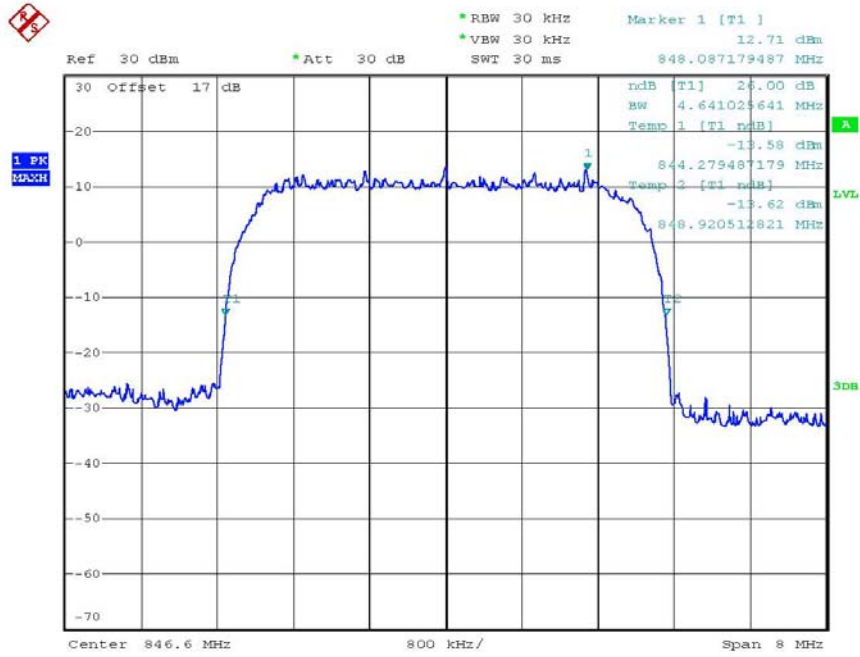

26DB BANDWIDTH WCDMA BAND V CH4233
Date: 22.APR.2017 16:28:52

Test equipment: ETSTW-RE 055, ETSTW-GSM 002



Report Number: W6M21703-16710-P-2224
FCC ID: 2ALG8RMBU3GTR

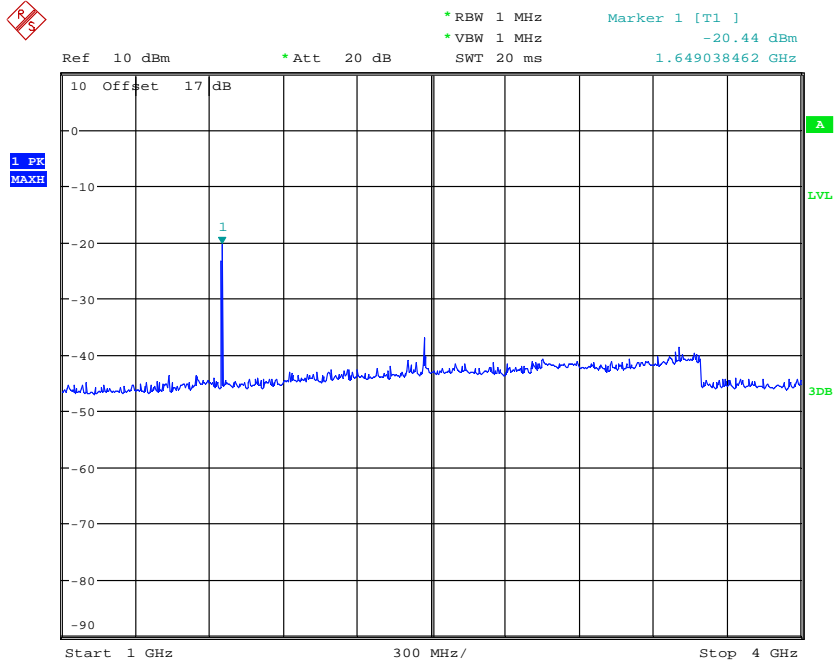

CONDUCTED SPURIOUS EMISSION GSM850 CH128
Date: 18.APR.2017 15:39:50

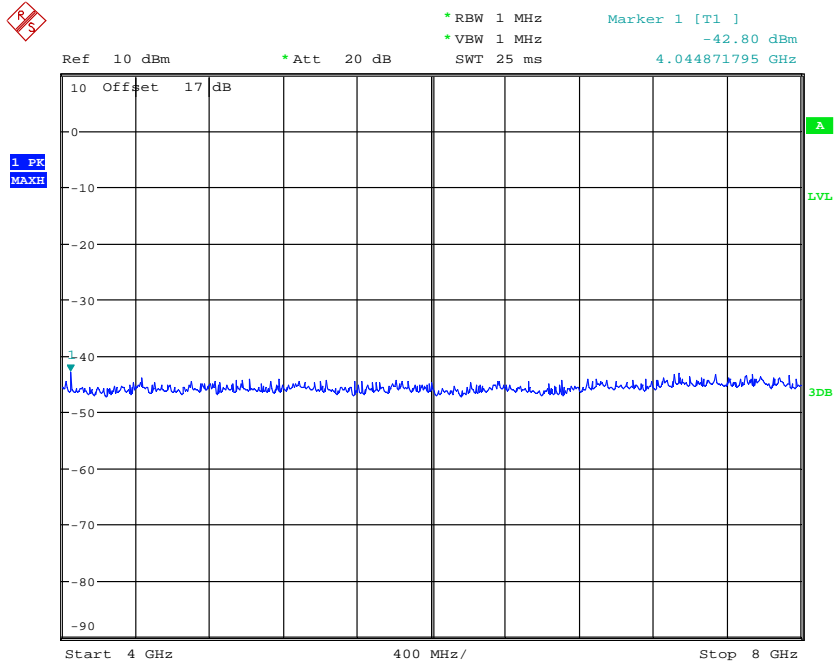

CONDUCTED SPURIOUS EMISSION GSM850 CH128
Date: 18.APR.2017 15:42:01



Report Number: W6M21703-16710-P-2224
FCC ID: 2ALG8RMBU3GTR

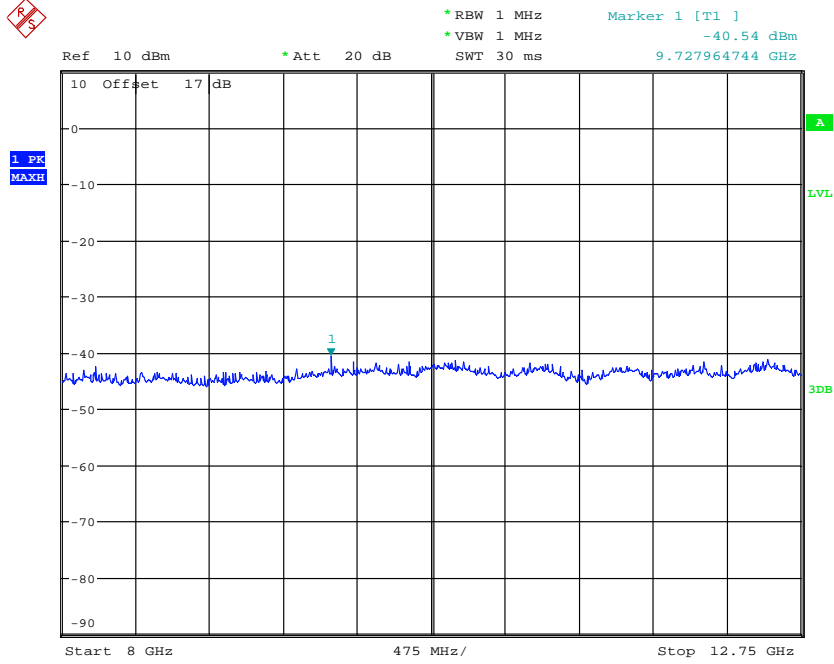

CONDUCTED SPURIOUS EMISSION GSM850 CH128
Date: 18.APR.2017 15:42:57

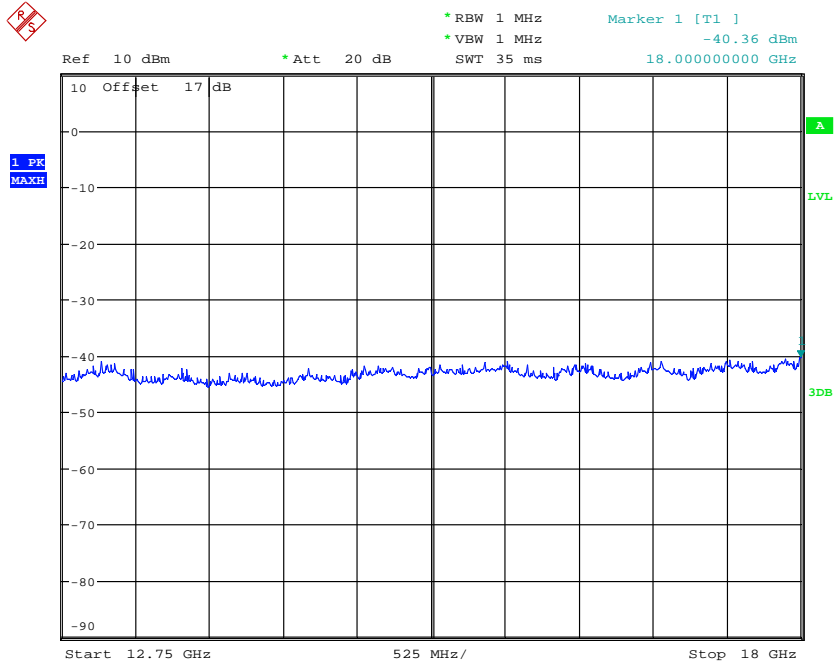

CONDUCTED SPURIOUS EMISSION GSM850 CH128
Date: 18.APR.2017 15:44:34



Report Number: W6M21703-16710-P-2224
FCC ID: 2ALG8RMBU3GTR

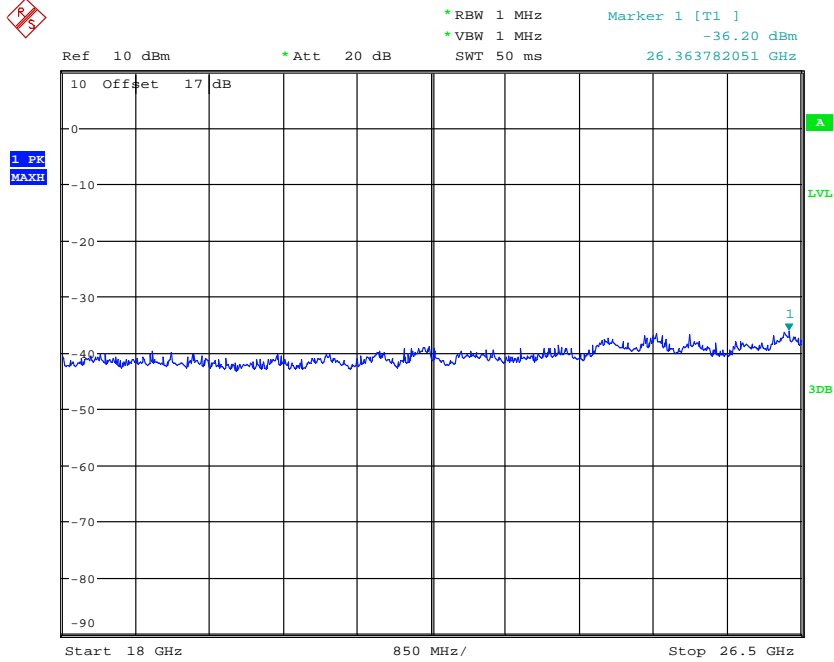

CONDUCTED SPURIOUS EMISSION GSM850 CH128
Date: 18.APR.2017 15:44:55

CH188

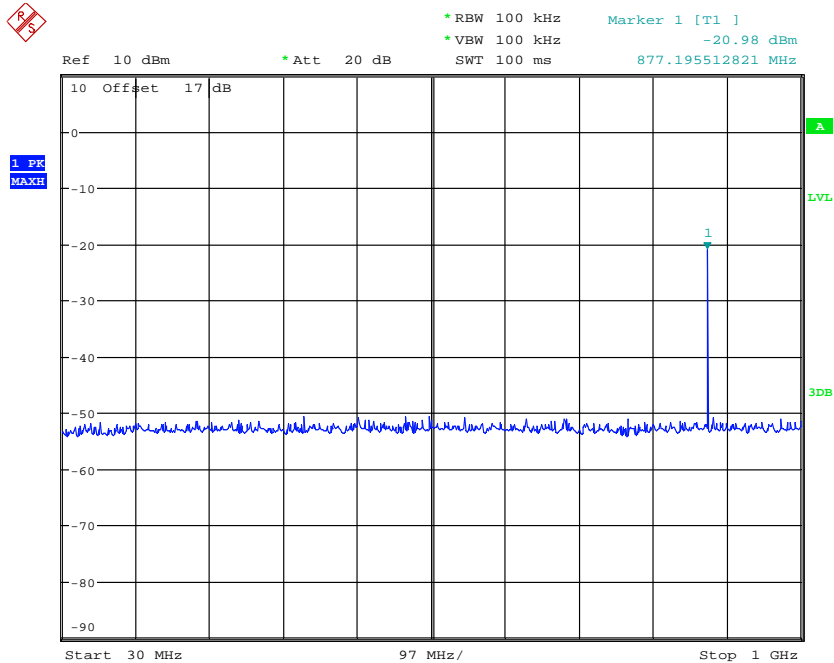

CONDUCTED SPURIOUS EMISSION GSM850 CH188
Date: 18.APR.2017 15:48:30



Report Number: W6M21703-16710-P-2224
FCC ID: 2ALG8RMBU3GTR

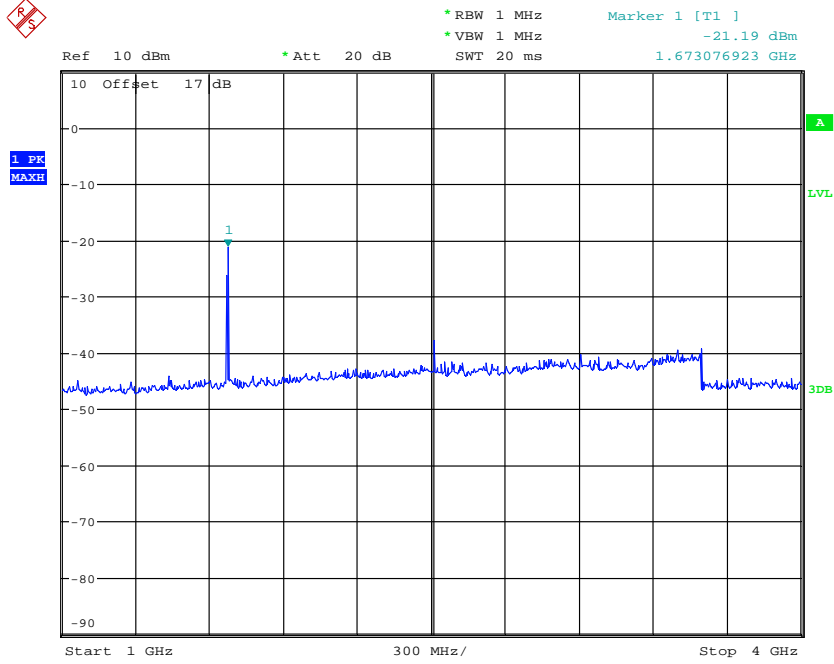

CONDUCTED SPURIOUS EMISSION GSM850 CH188
Date: 18.APR.2017 15:39:04

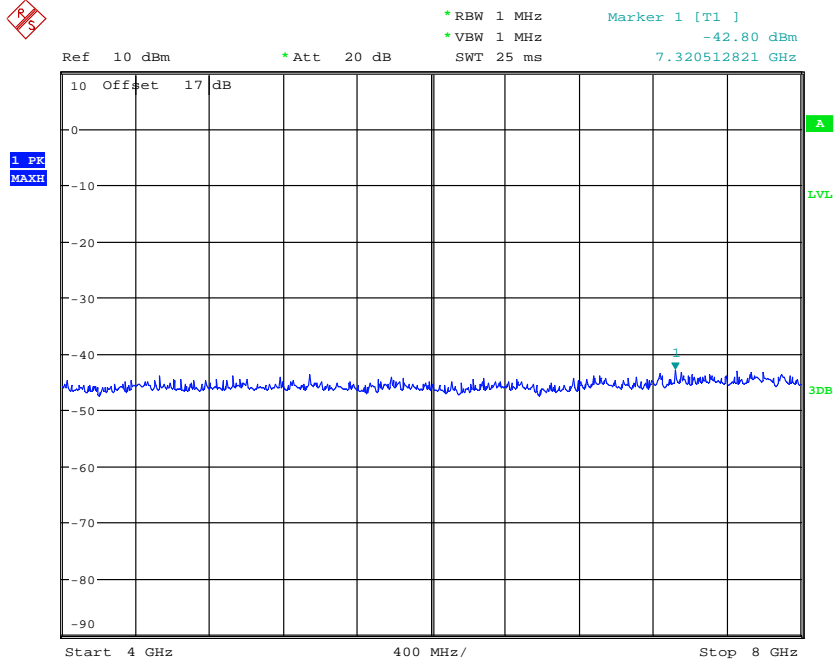

CONDUCTED SPURIOUS EMISSION GSM850 CH188
Date: 18.APR.2017 15:41:46



Report Number: W6M21703-16710-P-2224
FCC ID: 2ALG8RMBU3GTR

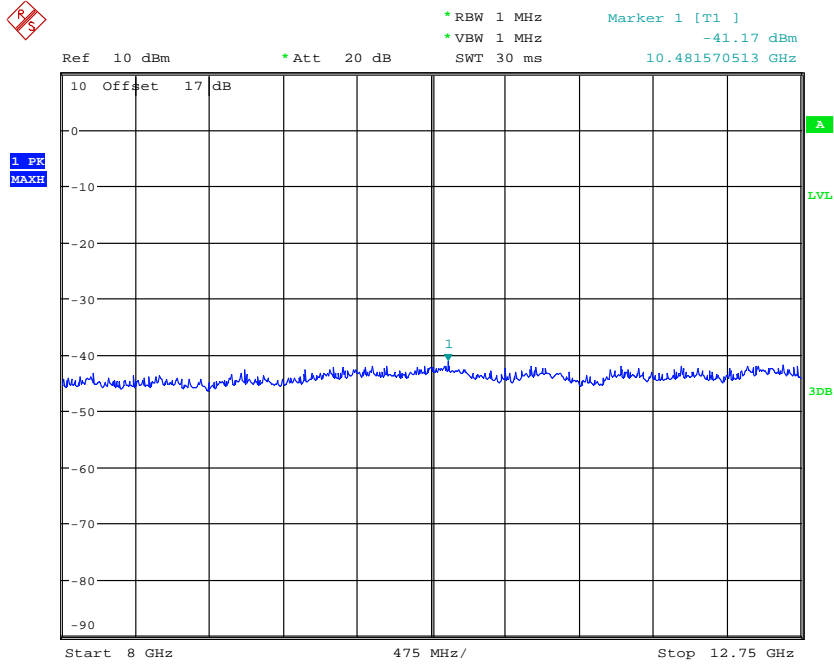

CONDUCTED SPURIOUS EMISSION GSM850 CH188
Date: 18.APR.2017 15:43:13

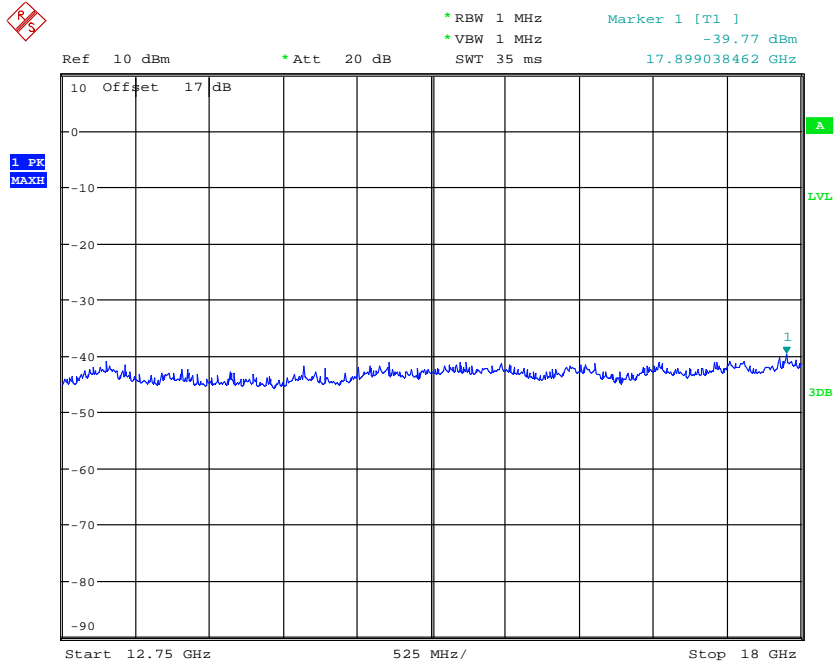

CONDUCTED SPURIOUS EMISSION GSM850 CH188
Date: 18.APR.2017 15:44:14

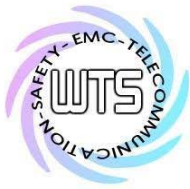

Report Number: W6M21703-16710-P-2224
FCC ID: 2ALG8RMBU3GTR

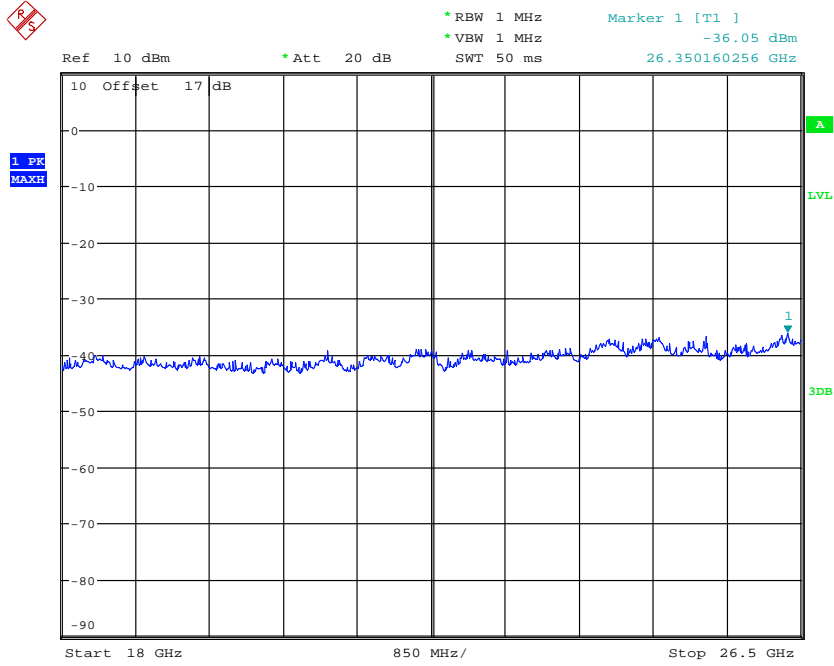

CONDUCTED SPURIOUS EMISSION GSM850 CH188
Date: 18.APR.2017 15:45:10

CH251

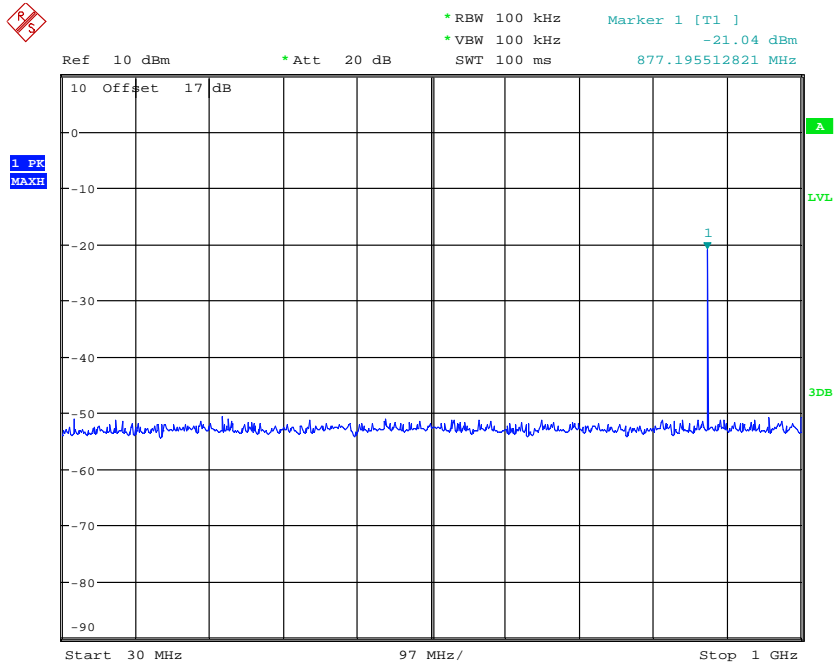

CONDUCTED SPURIOUS EMISSION GSM850 CH251
Date: 18.APR.2017 15:48:50



Report Number: W6M21703-16710-P-2224
FCC ID: 2ALG8RMBU3GTR

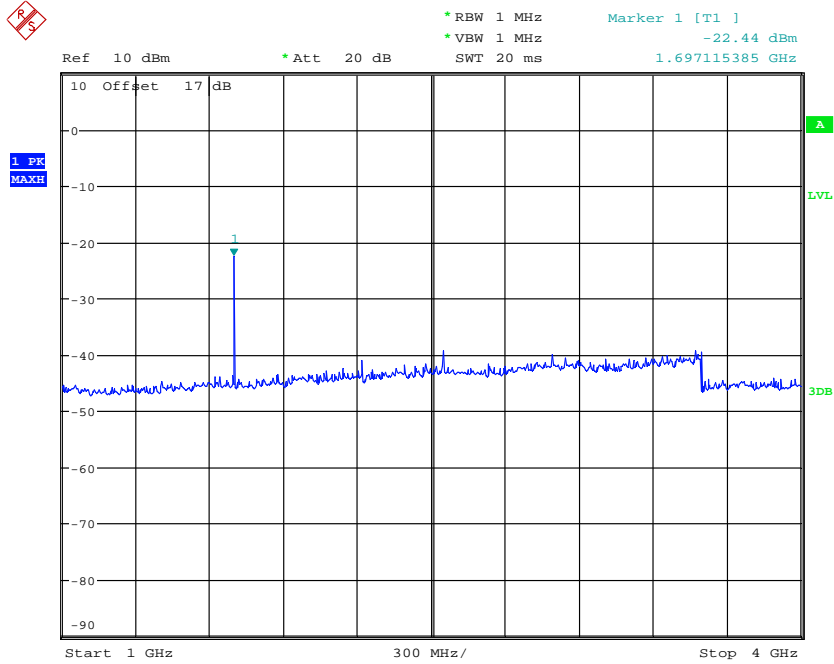

CONDUCTED SPURIOUS EMISSION GSM850 CH251
Date: 18.APR.2017 15:40:23

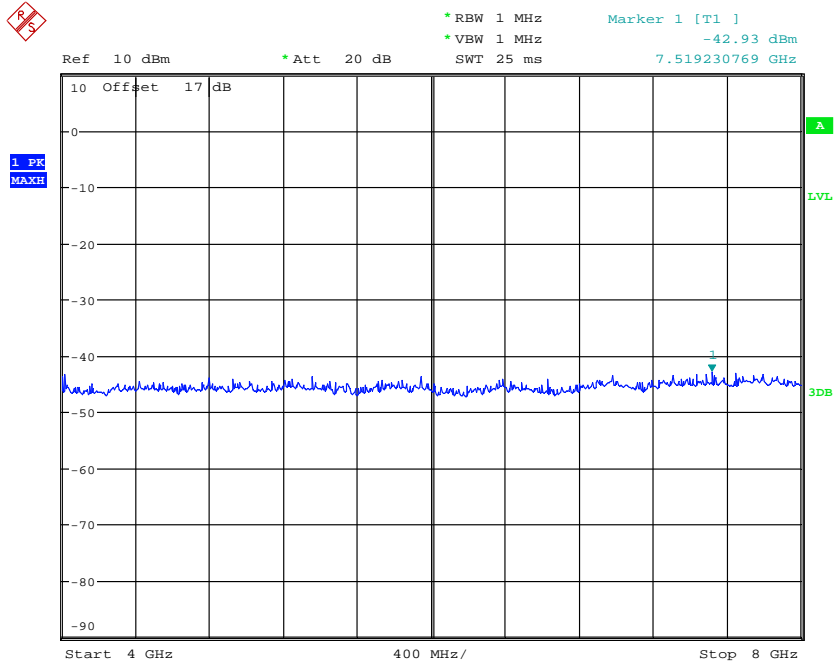

CONDUCTED SPURIOUS EMISSION GSM850 CH251
Date: 18.APR.2017 15:41:32



Report Number: W6M21703-16710-P-2224
FCC ID: 2ALG8RMBU3GTR

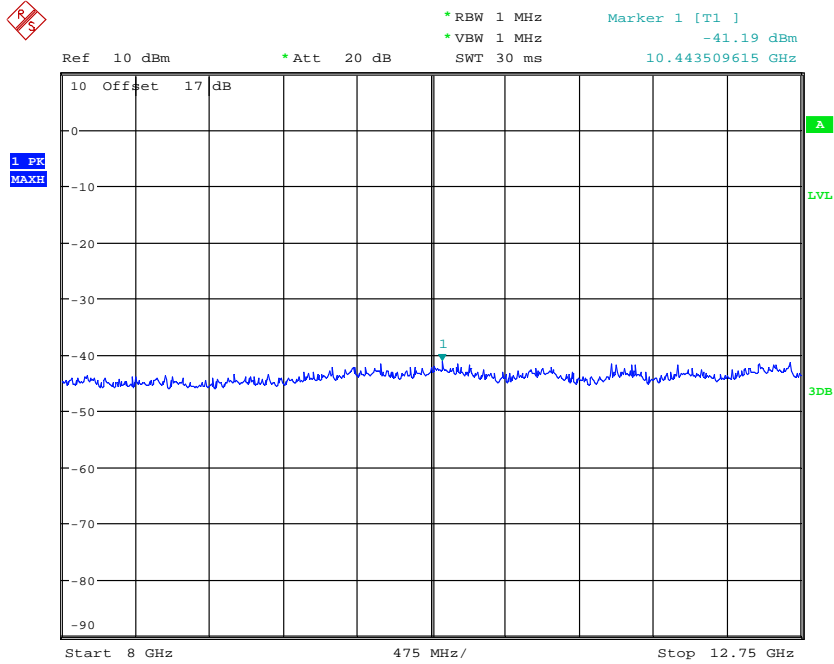

CONDUCTED SPURIOUS EMISSION GSM850 CH251
Date: 18.APR.2017 15:43:28

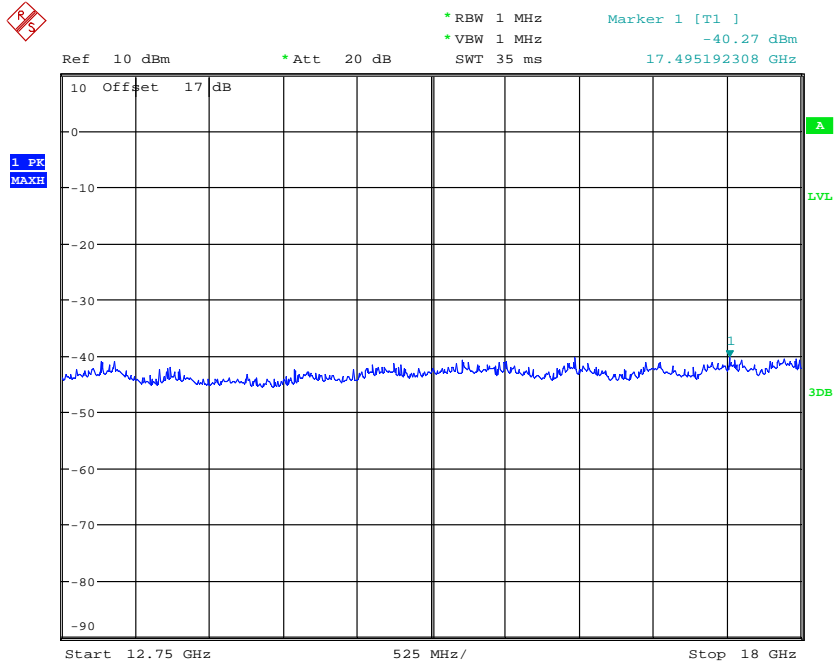

CONDUCTED SPURIOUS EMISSION GSM850 CH251
Date: 18.APR.2017 15:43:54



Report Number: W6M21703-16710-P-2224
FCC ID: 2ALG8RMBU3GTR

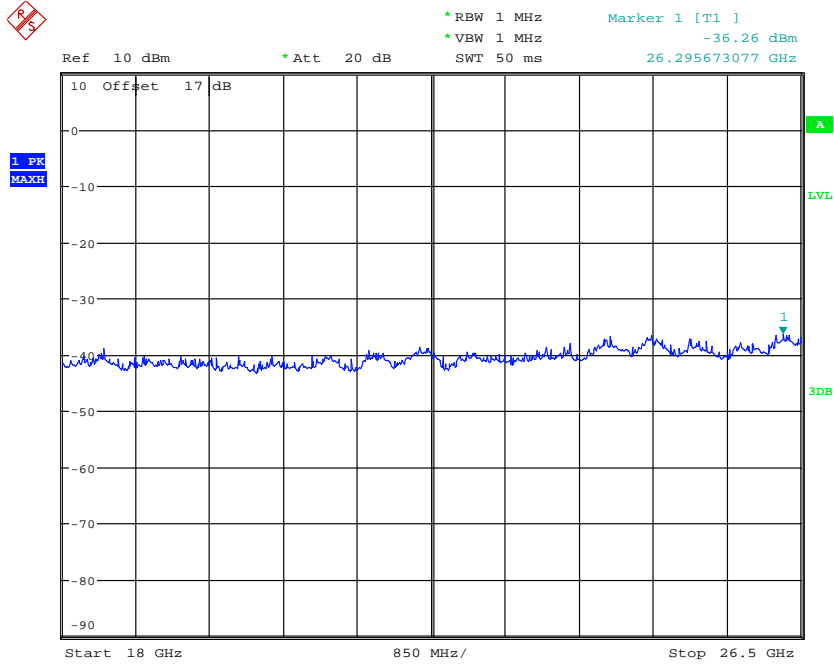

CONDUCTED SPURIOUS EMISSION GSM850 CH251
Date: 18.APR.2017 15:45:27

850 Band Idle

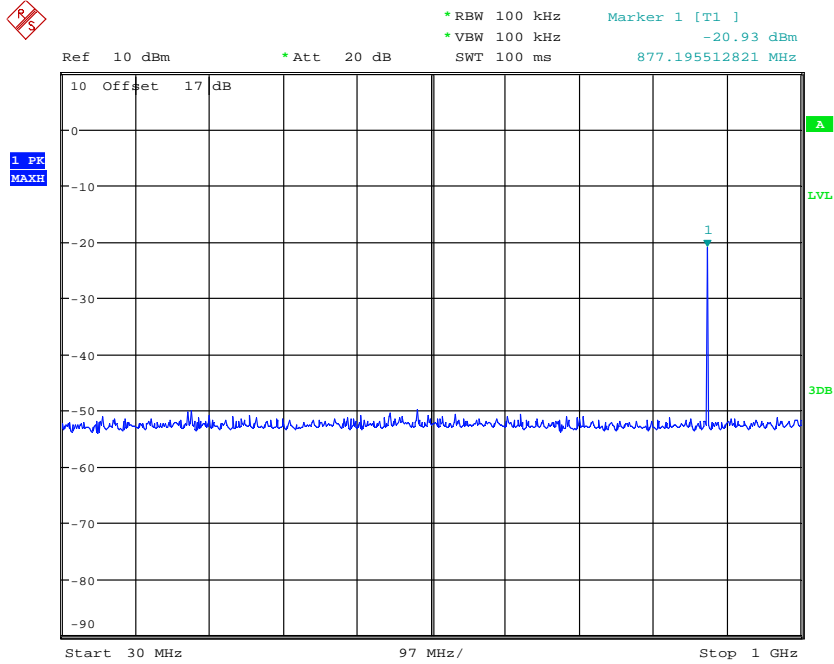

CONDUCTED SPURIOUS EMISSION GSM850 IDLE
Date: 18.APR.2017 15:49:54



Report Number: W6M21703-16710-P-2224
FCC ID: 2ALG8RMBU3GTR

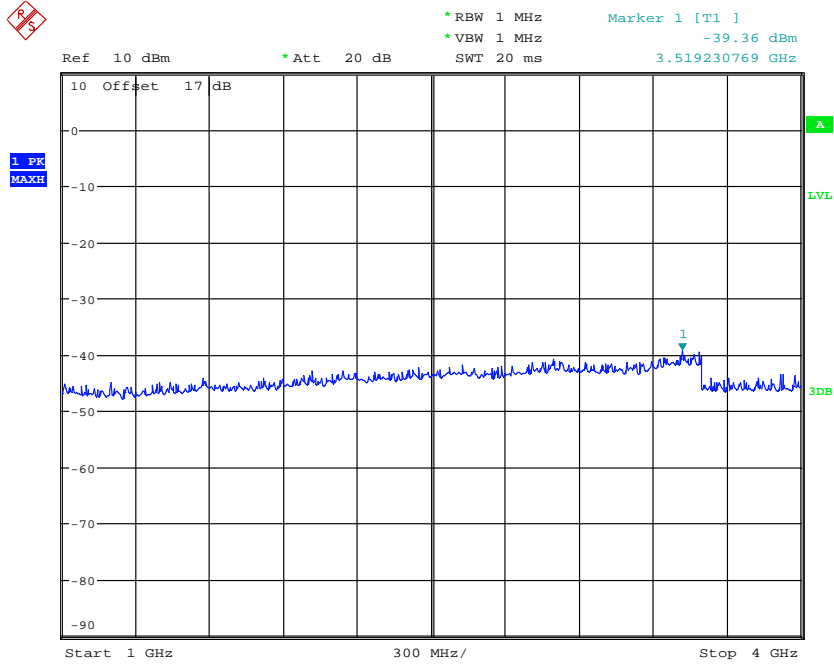

CONDUCTED SPURIOUS EMISSION GSM850 IDLE
Date: 18.APR.2017 15:50:21

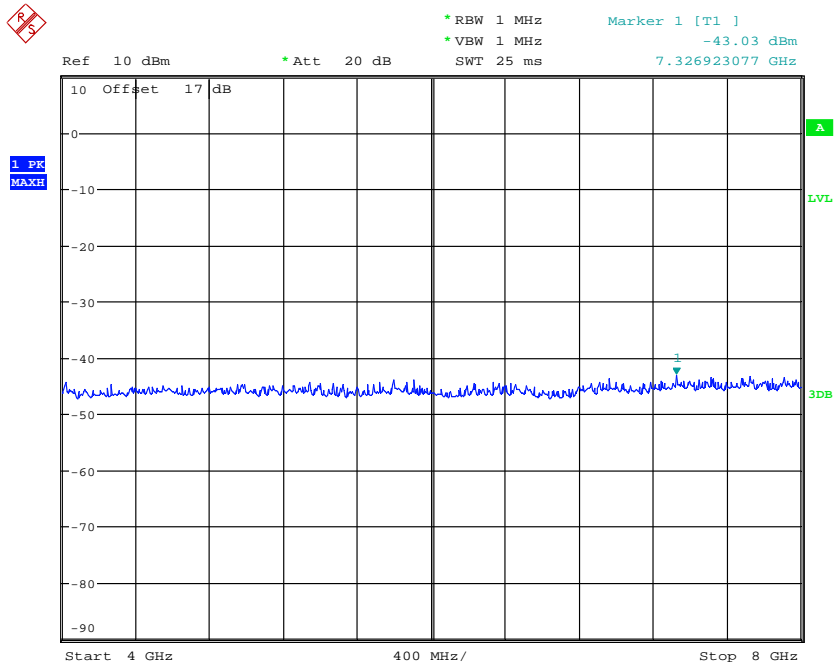

CONDUCTED SPURIOUS EMISSION GSM850 IDLE
Date: 18.APR.2017 15:50:36



Report Number: W6M21703-16710-P-2224
FCC ID: 2ALG8RMBU3GTR

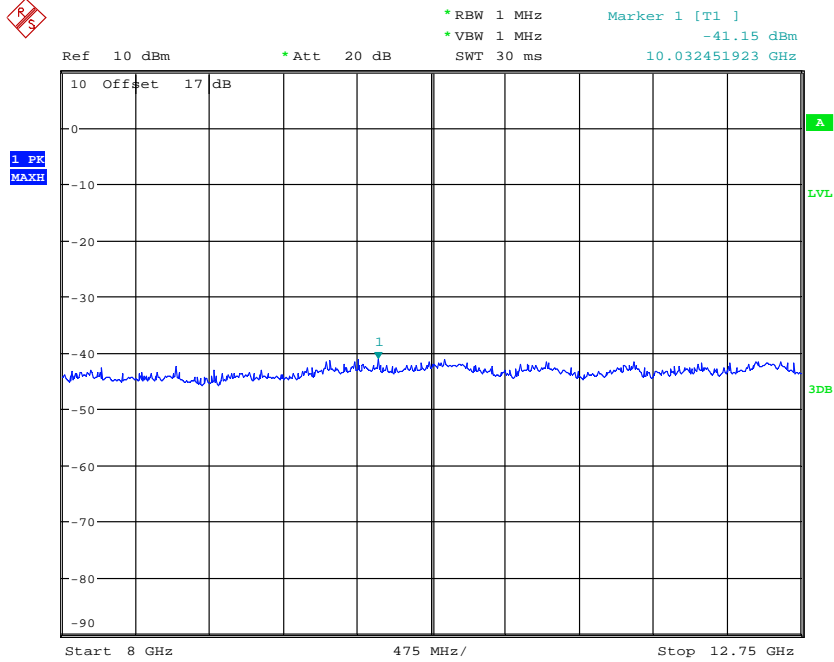

CONDUCTED SPURIOUS EMISSION GSM850 IDLE
Date: 18.APR.2017 15:51:28

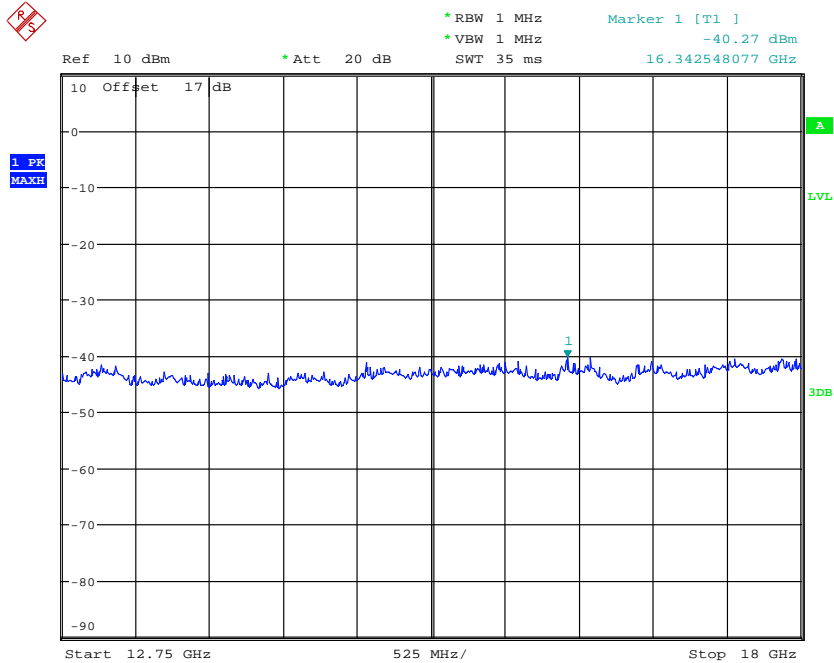

CONDUCTED SPURIOUS EMISSION GSM850 IDLE
Date: 18.APR.2017 15:51:45



Report Number: W6M21703-16710-P-2224
FCC ID: 2ALG8RMBU3GTR

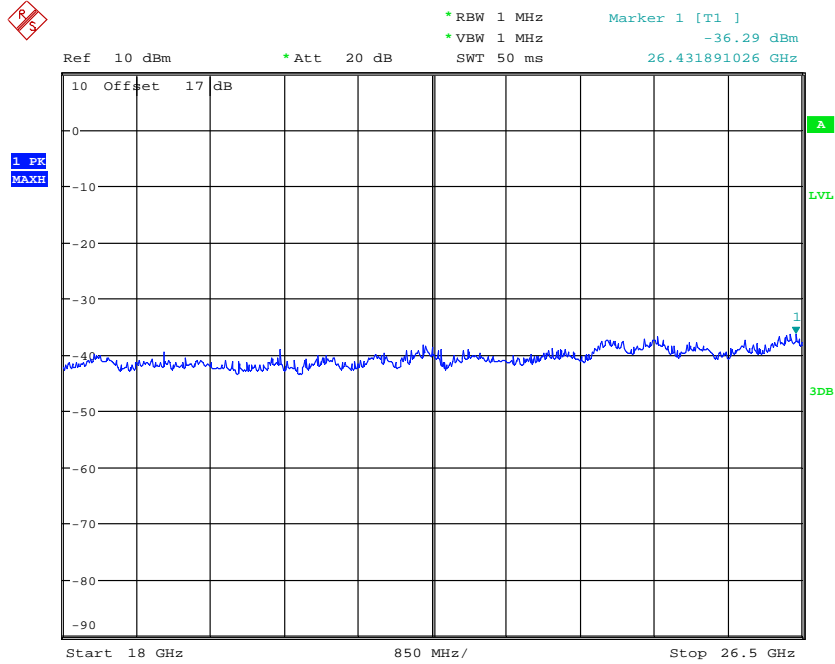

CONDUCTED SPURIOUS EMISSION GSM850 IDLE
Date: 18.APR.2017 15:52:03

Band 1900 MHz
CH512

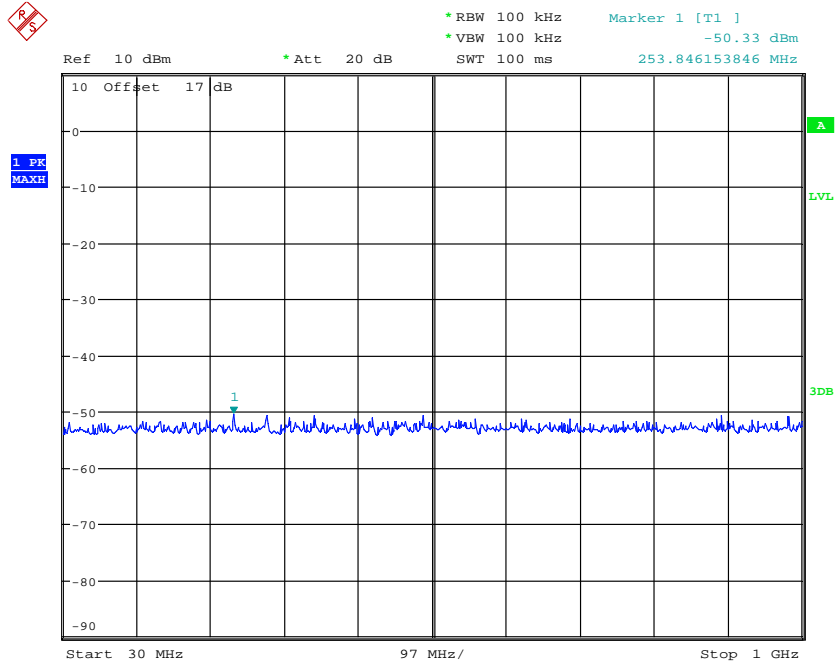

CONDUCTED SPURIOUS EMISSION DCS1900 CH512
Date: 18.APR.2017 16:00:18



Report Number: W6M21703-16710-P-2224
FCC ID: 2ALG8RMBU3GTR

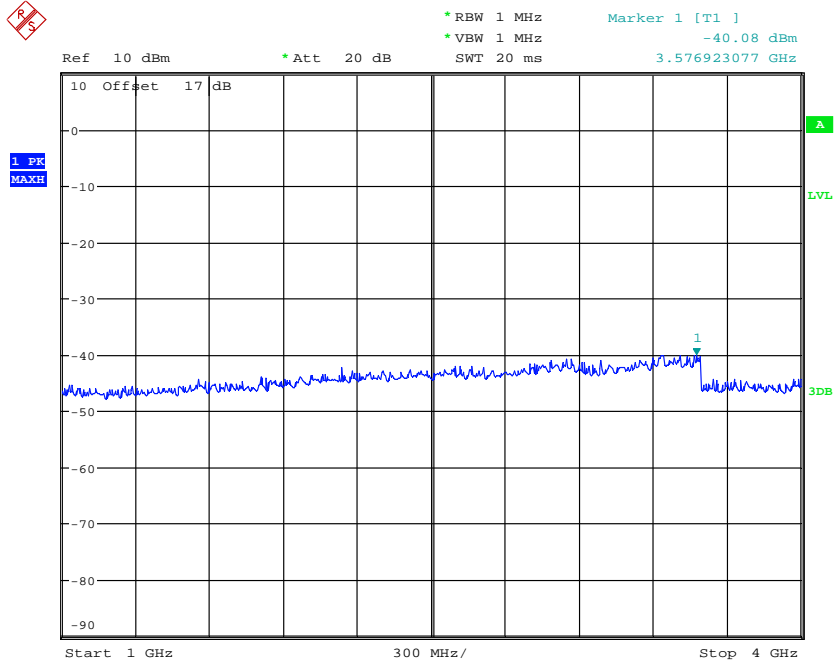

CONDUCTED SPURIOUS EMISSION DCS1900 CH512
Date: 18.APR.2017 16:01:56

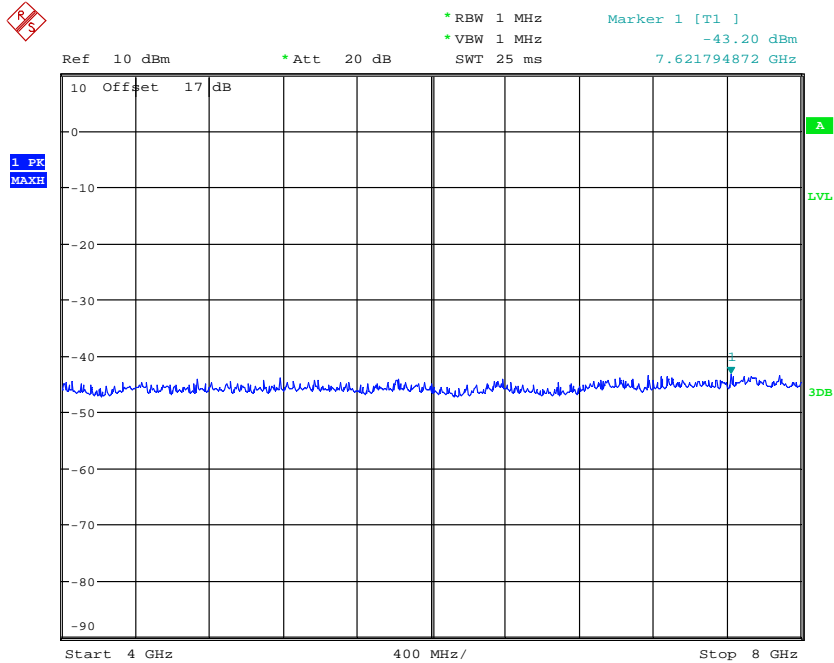

CONDUCTED SPURIOUS EMISSION DCS1900 CH512
Date: 18.APR.2017 16:02:15



Report Number: W6M21703-16710-P-2224
FCC ID: 2ALG8RMBU3GTR

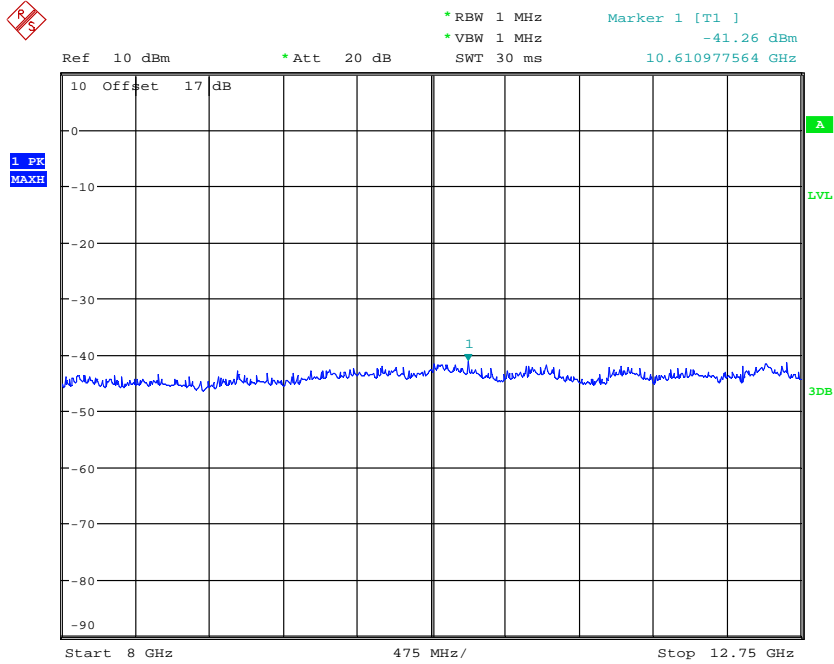

CONDUCTED SPURIOUS EMISSION DCS1900 CH512
Date: 18.APR.2017 16:03:46

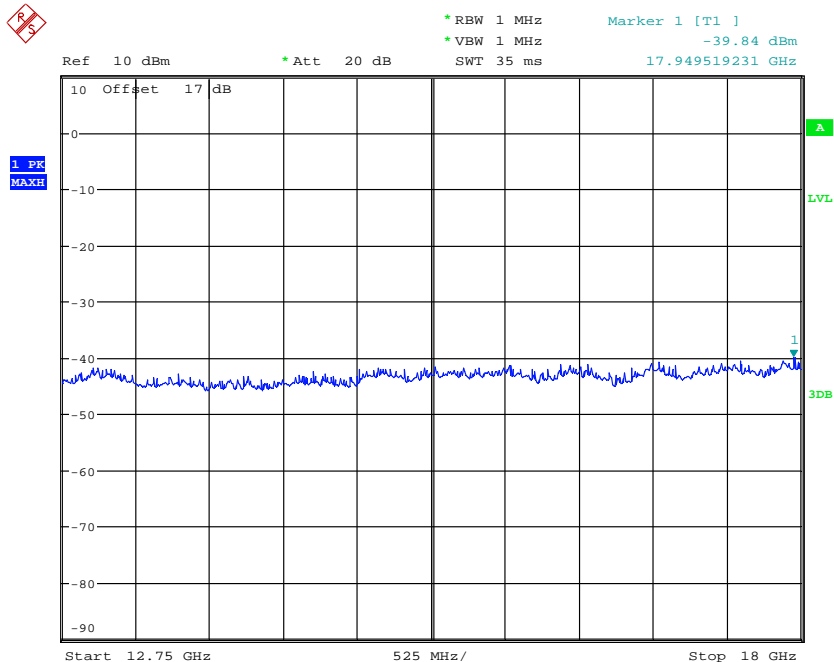

CONDUCTED SPURIOUS EMISSION DCS1900 CH512
Date: 18.APR.2017 16:04:20



Report Number: W6M21703-16710-P-2224
FCC ID: 2ALG8RMBU3GTR

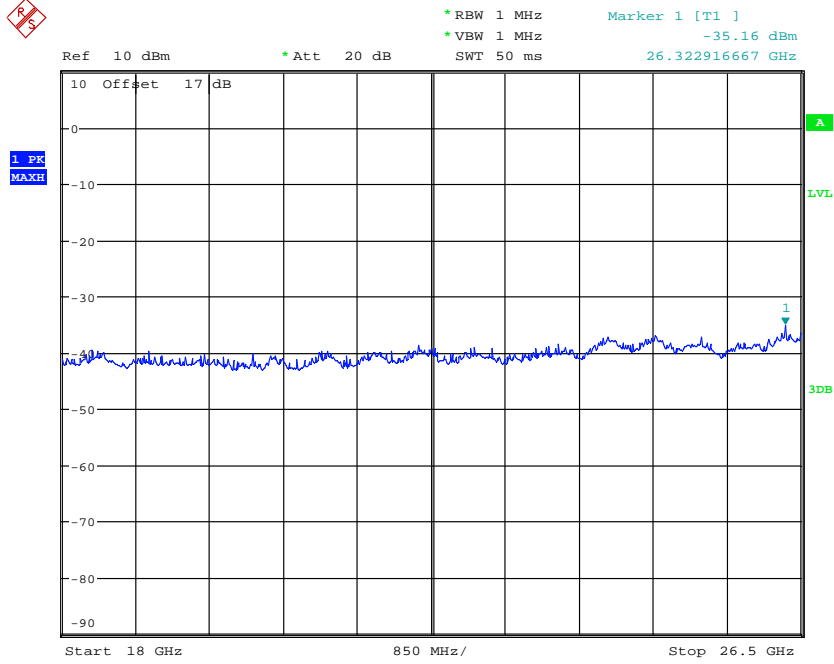

CONDUCTED SPURIOUS EMISSION DCS1900 CH512
Date: 18.APR.2017 16:06:15

CH661

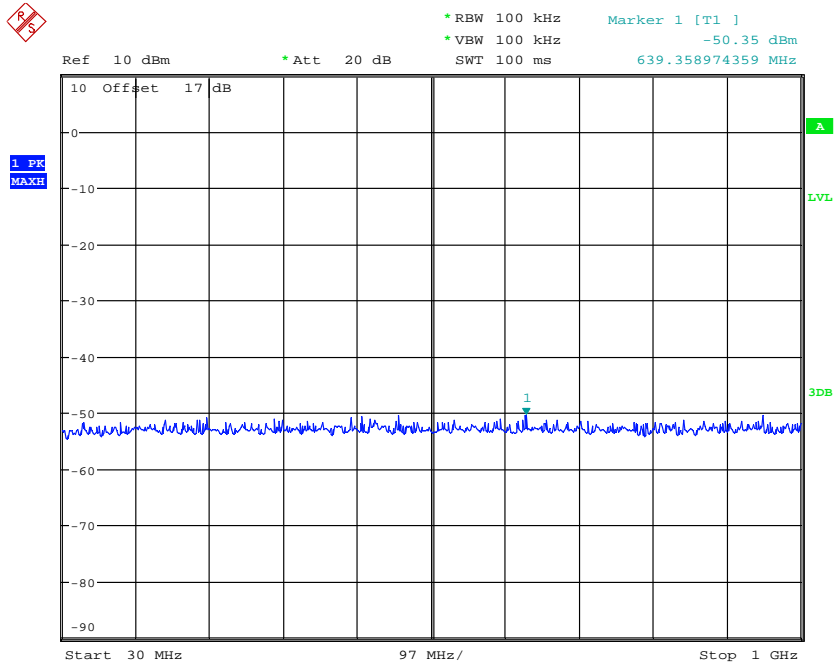

CONDUCTED SPURIOUS EMISSION DCS1900 CH661
Date: 18.APR.2017 16:00:34



Report Number: W6M21703-16710-P-2224
FCC ID: 2ALG8RMBU3GTR

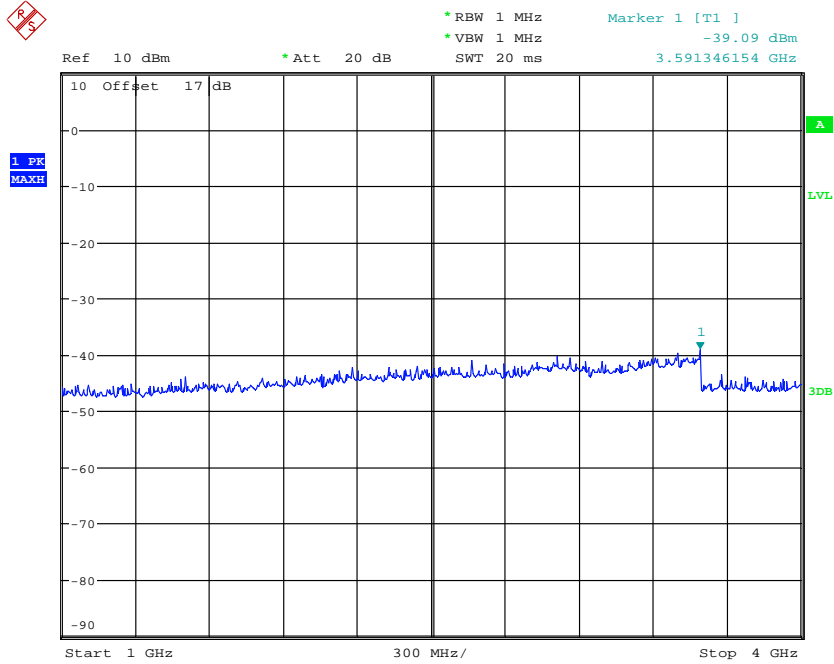

CONDUCTED SPURIOUS EMISSION DCS1900 CH661
Date: 18.APR.2017 16:01:41

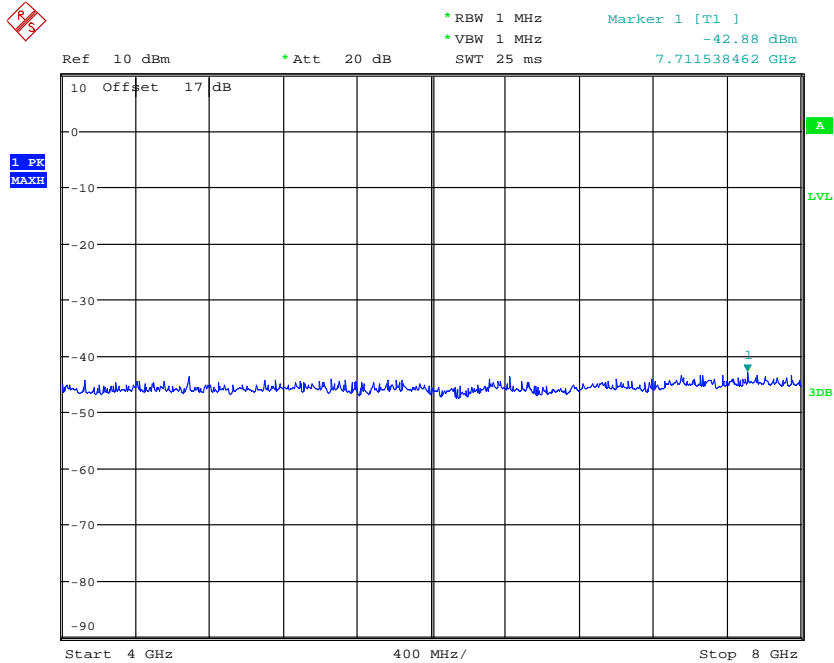

CONDUCTED SPURIOUS EMISSION DCS1900 CH661
Date: 18.APR.2017 16:02:30



Report Number: W6M21703-16710-P-2224
FCC ID: 2ALG8RMBU3GTR

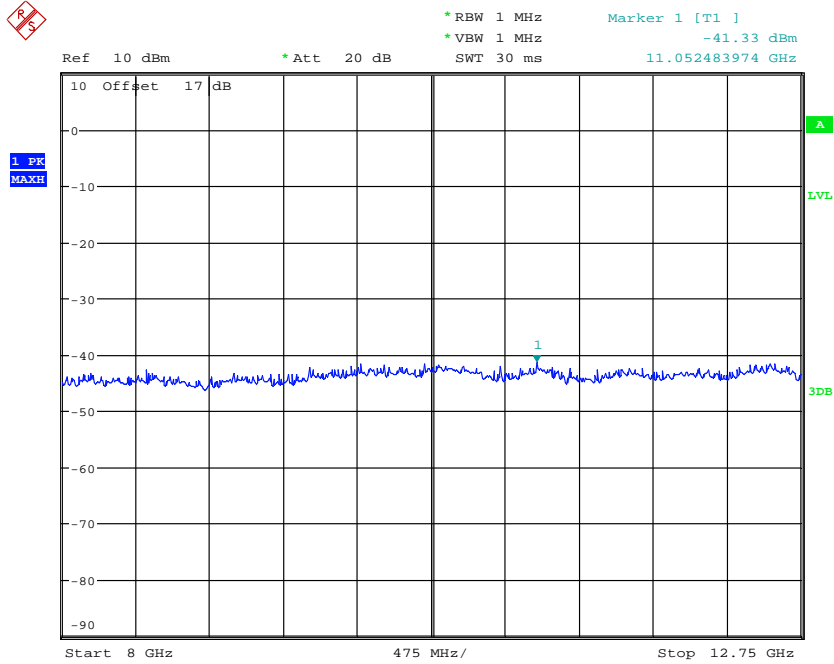

CONDUCTED SPURIOUS EMISSION DCS1900 CH661
Date: 18.APR.2017 16:03:29

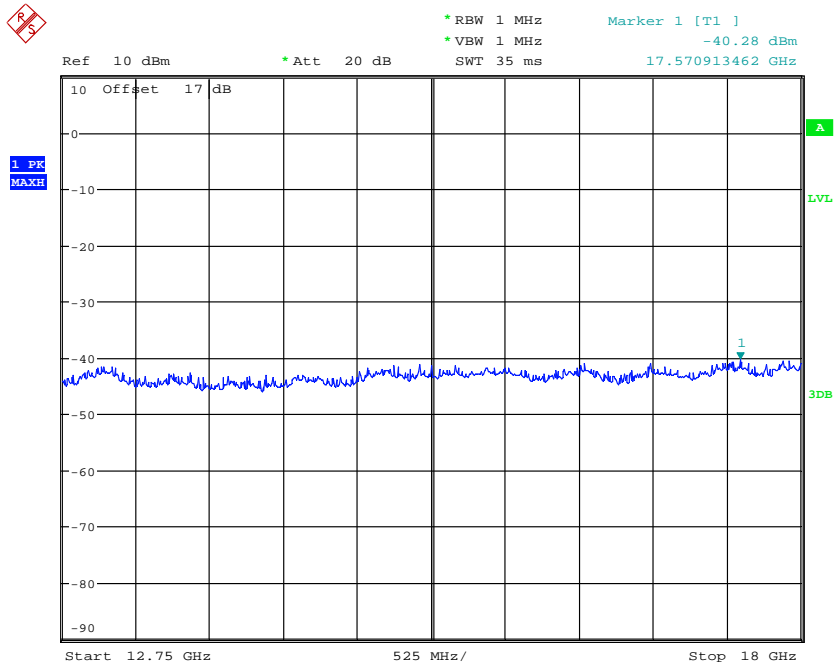

CONDUCTED SPURIOUS EMISSION DCS1900 CH661
Date: 18.APR.2017 16:04:37

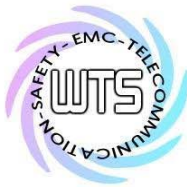

Report Number: W6M21703-16710-P-2224
 FCC ID: 2ALG8RMBU3GTR

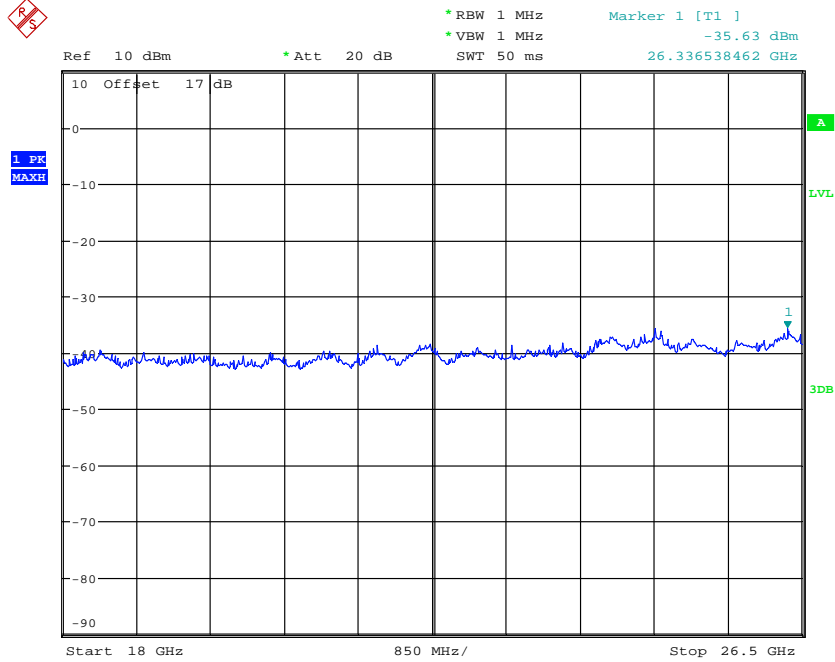

CONDUCTED SPURIOUS EMISSION DCS1900 CH661
 Date: 18.APR.2017 16:05:56

CH810

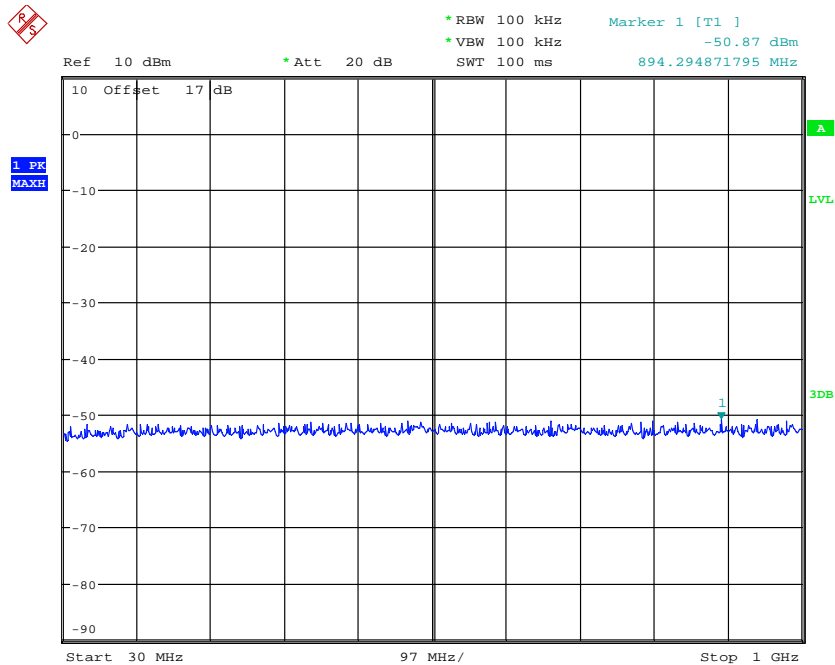

CONDUCTED SPURIOUS EMISSION DCS1900 CH810
 Date: 18.APR.2017 16:00:50



Report Number: W6M21703-16710-P-2224
FCC ID: 2ALG8RMBU3GTR

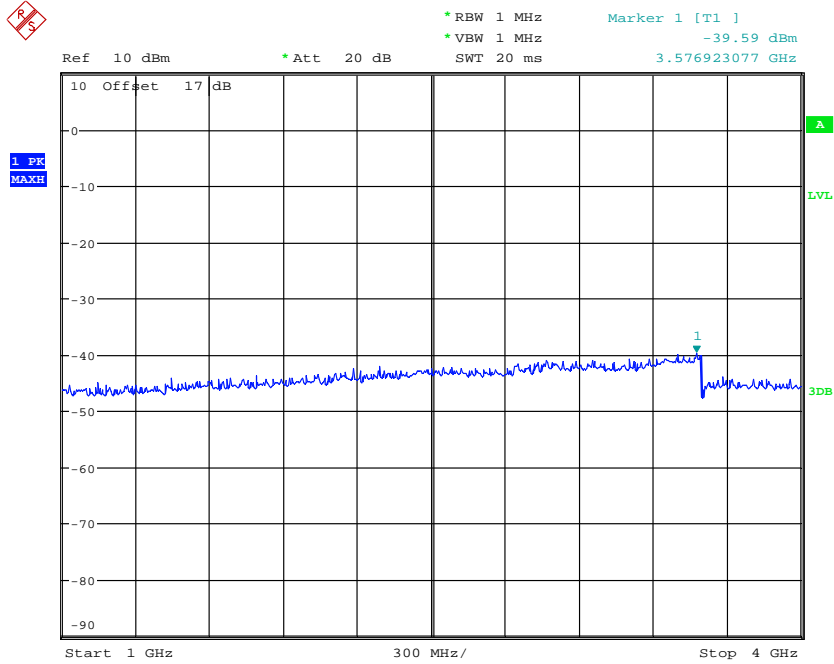

CONDUCTED SPURIOUS EMISSION DCS1900 CH810
Date: 18.APR.2017 16:01:24

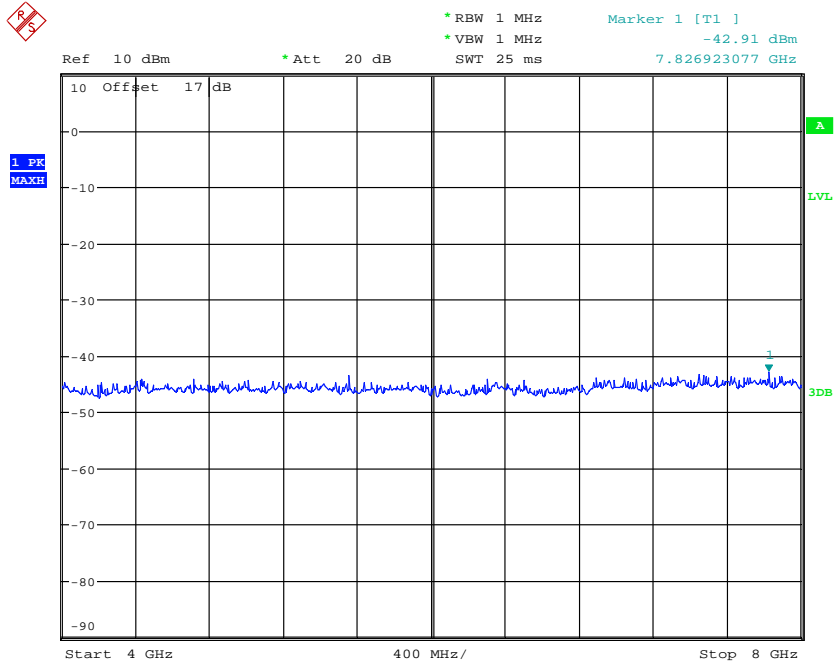

CONDUCTED SPURIOUS EMISSION DCS1900 CH810
Date: 18.APR.2017 16:02:45

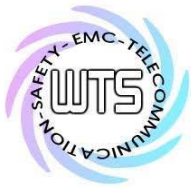

Report Number: W6M21703-16710-P-2224
FCC ID: 2ALG8RMBU3GTR

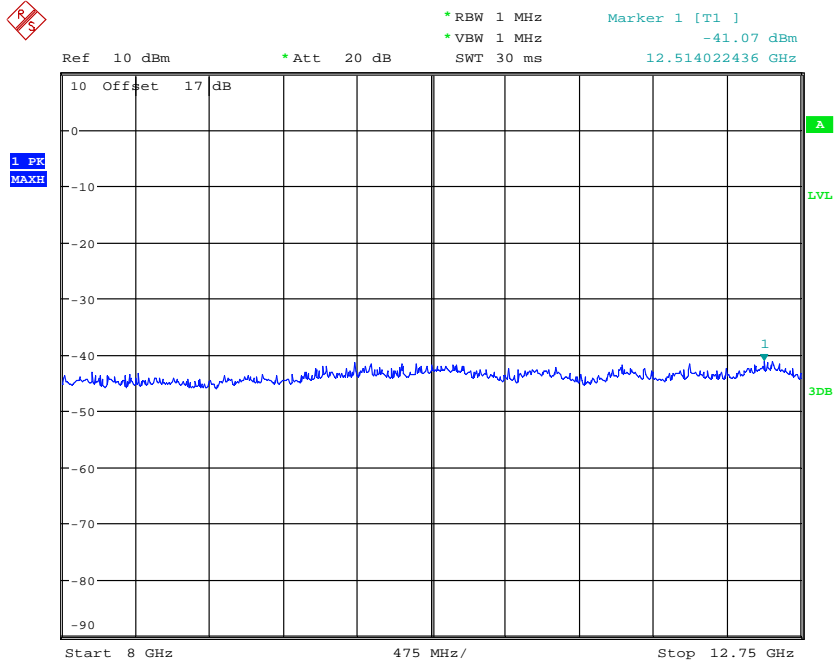

CONDUCTED SPURIOUS EMISSION DCS1900 CH810
Date: 18.APR.2017 16:03:08

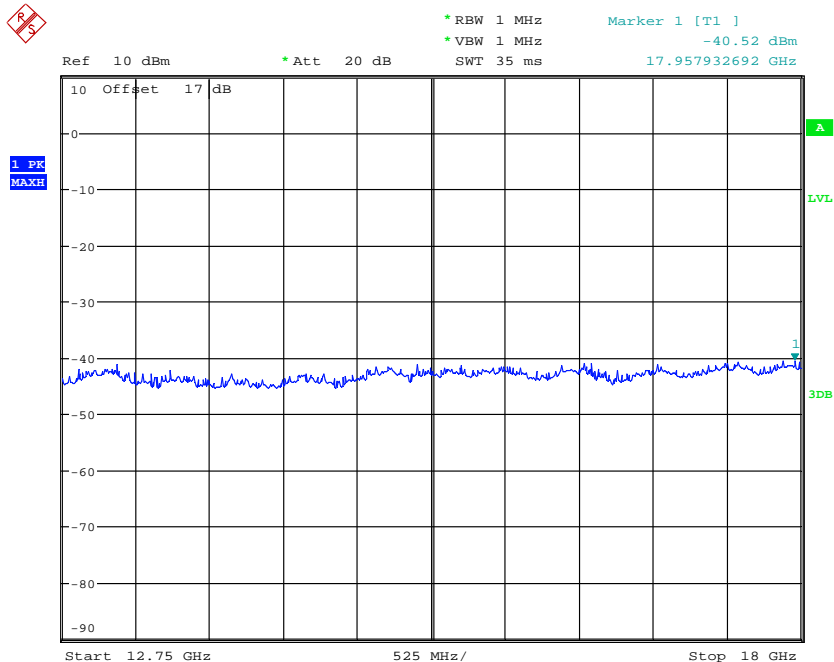

CONDUCTED SPURIOUS EMISSION DCS1900 CH810
Date: 18.APR.2017 16:04:58



Report Number: W6M21703-16710-P-2224
FCC ID: 2ALG8RMBU3GTR

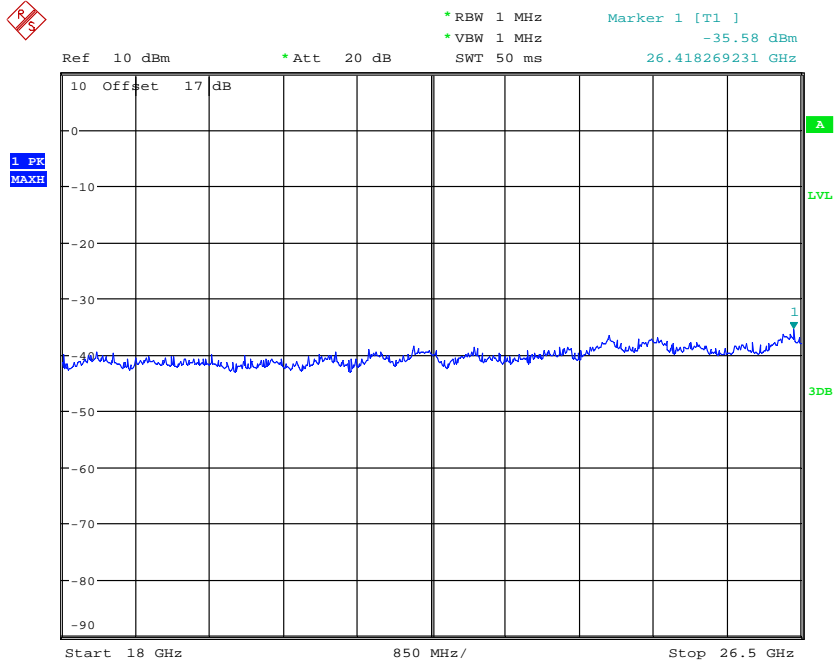

CONDUCTED SPURIOUS EMISSION DCS1900 CH810
Date: 18.APR.2017 16:05:29

1900 Band Idle

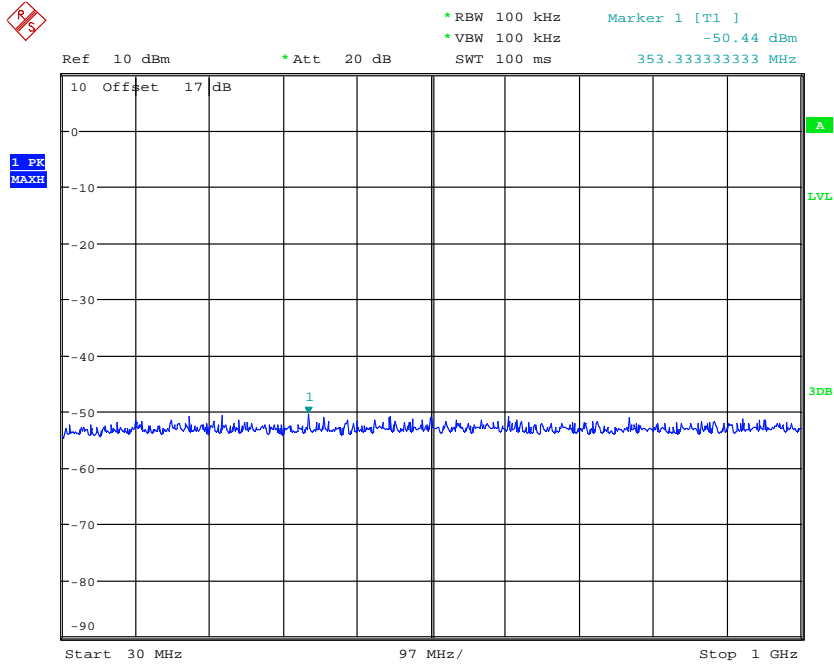

CONDUCTED SPURIOUS EMISSION DCS1900 IDLE
Date: 18.APR.2017 15:59:56



Report Number: W6M21703-16710-P-2224
FCC ID: 2ALG8RMBU3GTR

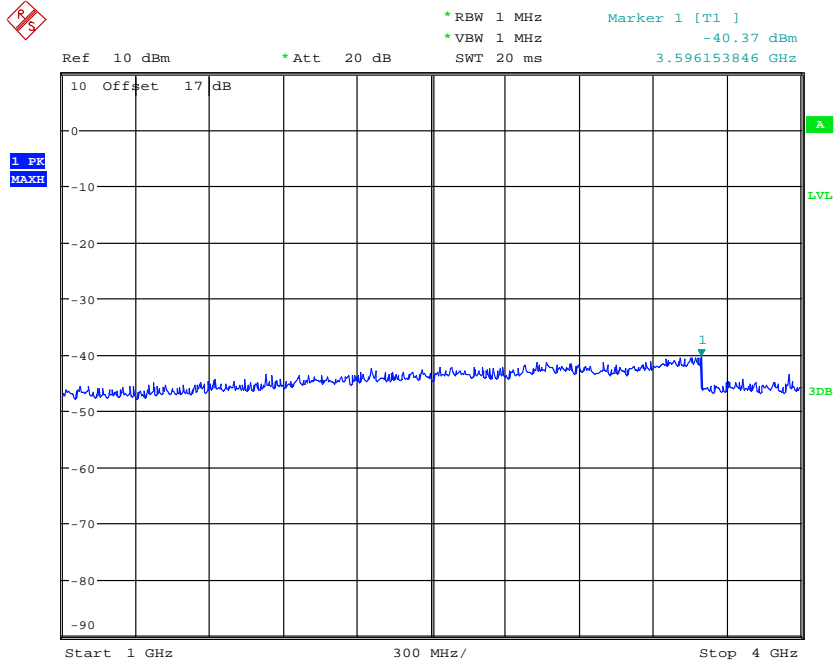

CONDUCTED SPURIOUS EMISSION DCS1900 IDLE
Date: 18.APR.2017 15:55:00

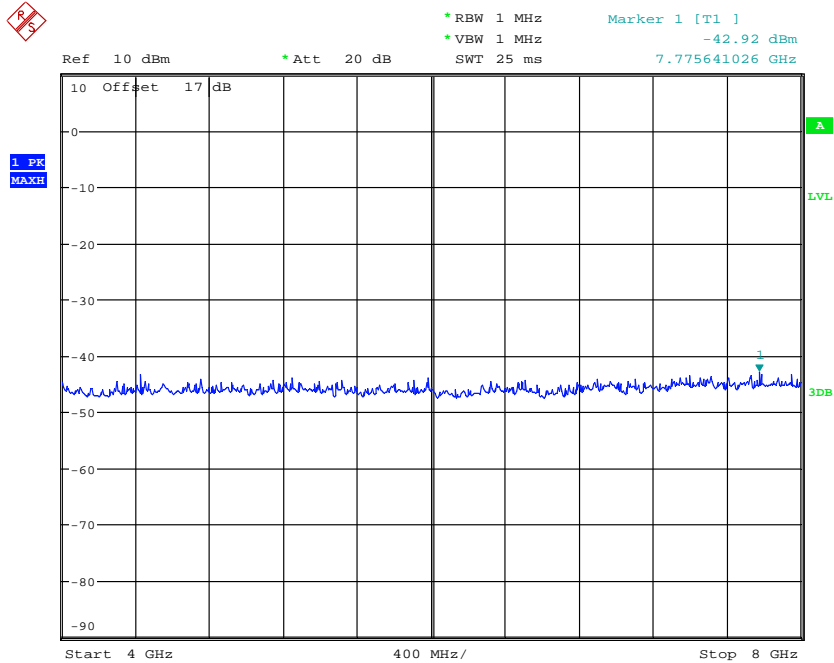

CONDUCTED SPURIOUS EMISSION DCS1900 IDLE
Date: 18.APR.2017 15:54:44



Report Number: W6M21703-16710-P-2224
FCC ID: 2ALG8RMBU3GTR

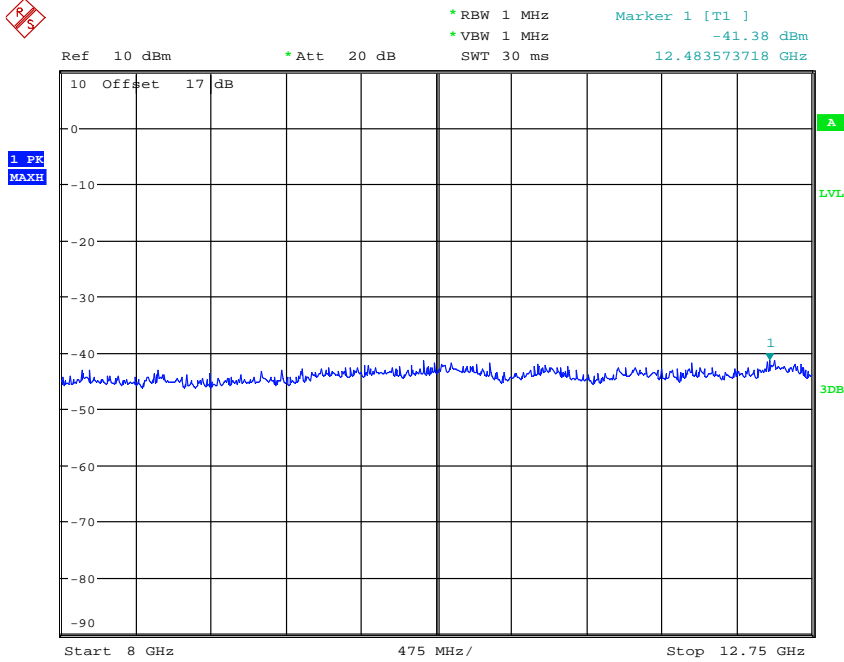

CONDUCTED SPURIOUS EMISSION DCS1900 IDLE
Date: 18.APR.2017 15:54:30

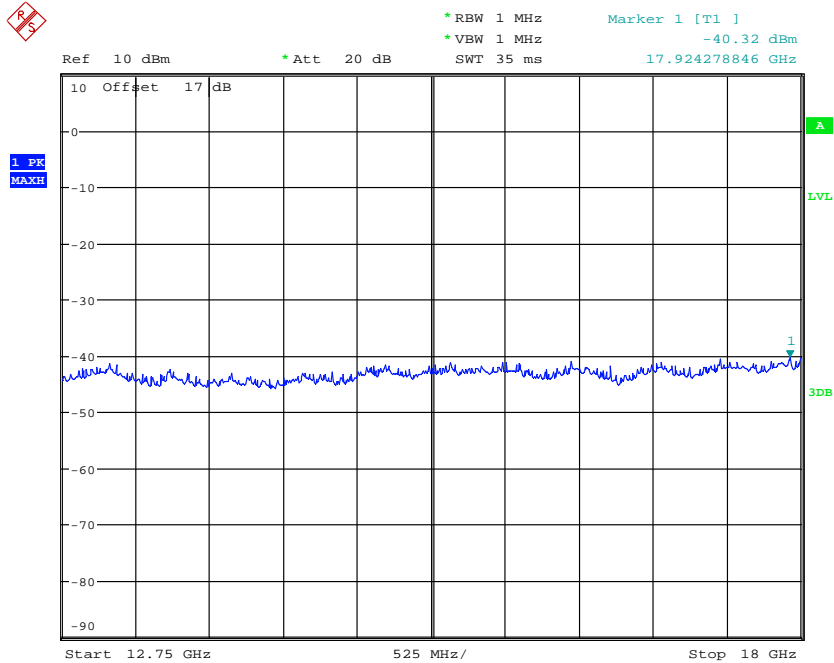

CONDUCTED SPURIOUS EMISSION DCS1900 IDLE
Date: 18.APR.2017 15:54:14



Report Number: W6M21703-16710-P-2224
FCC ID: 2ALG8RMBU3GTR

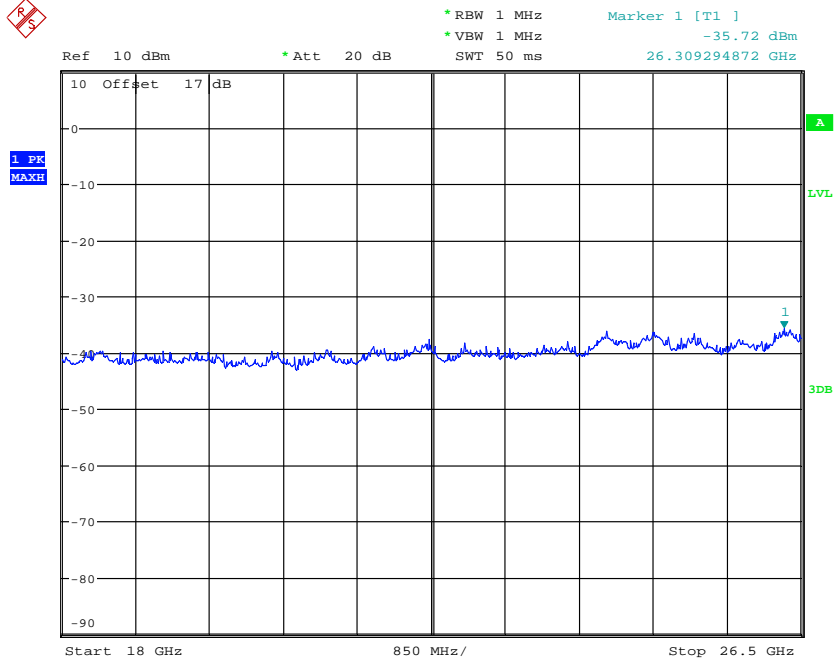

CONDUCTED SPURIOUS EMISSION DCS1900 IDLE
Date: 18.APR.2017 15:53:51

Band II
CH9262

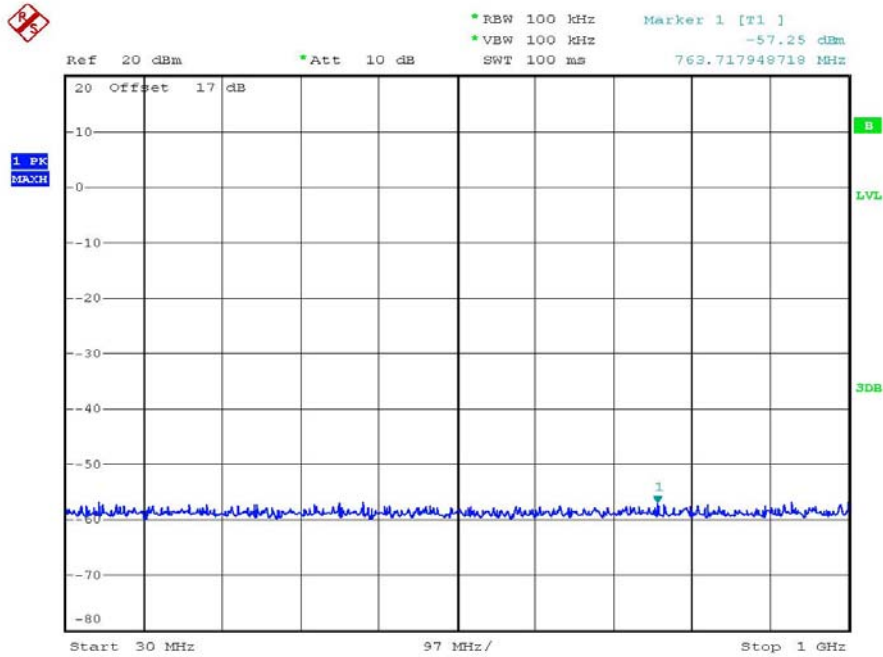

CONDUCTED SPURIOUS EMISSION WCDMA BAND II CH9262
Date: 22.APR.2017 21:19:20



Worldwide Testing Services(Taiwan) Co., Ltd.

Report Number: W6M21703-16710-P-2224
FCC ID: 2ALG8RMBU3GTR

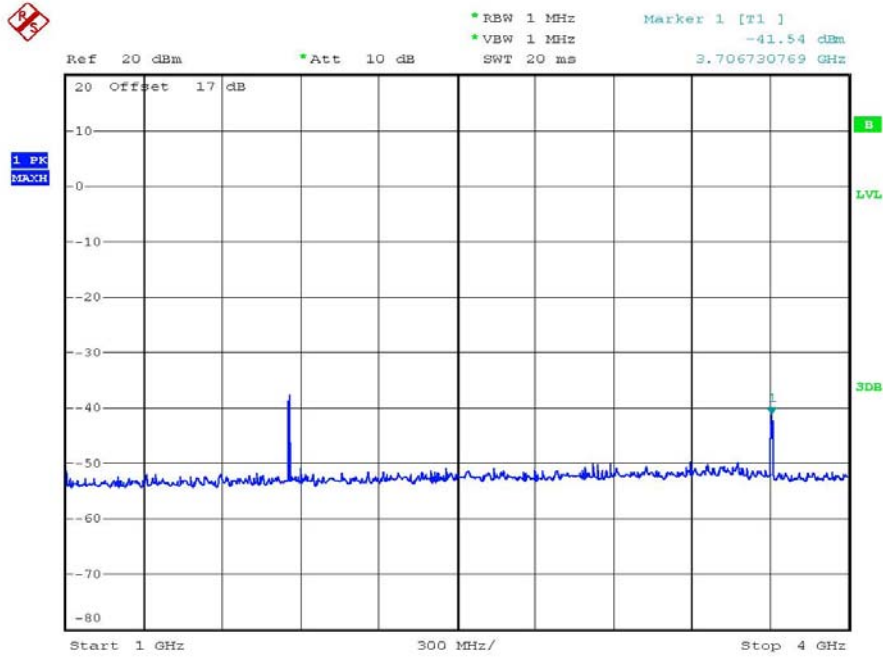

CONDUCTED SPURIOUS EMISSION WCDMA BAND II CH9262
Date: 22.APR.2017 21:23:08

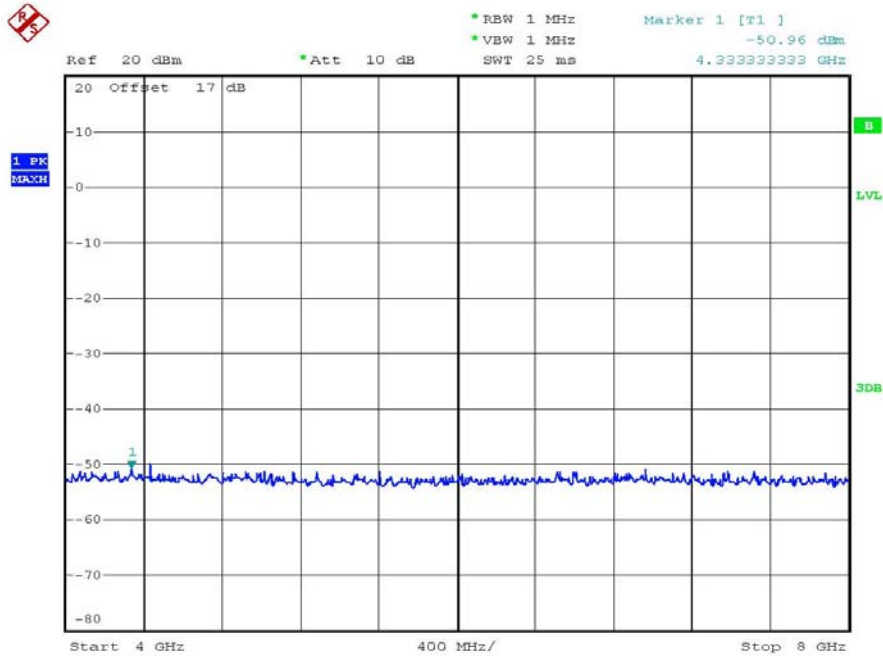

CONDUCTED SPURIOUS EMISSION WCDMA BAND II CH9262
Date: 22.APR.2017 21:27:15



Report Number: W6M21703-16710-P-2224
FCC ID: 2ALG8RMBU3GTR

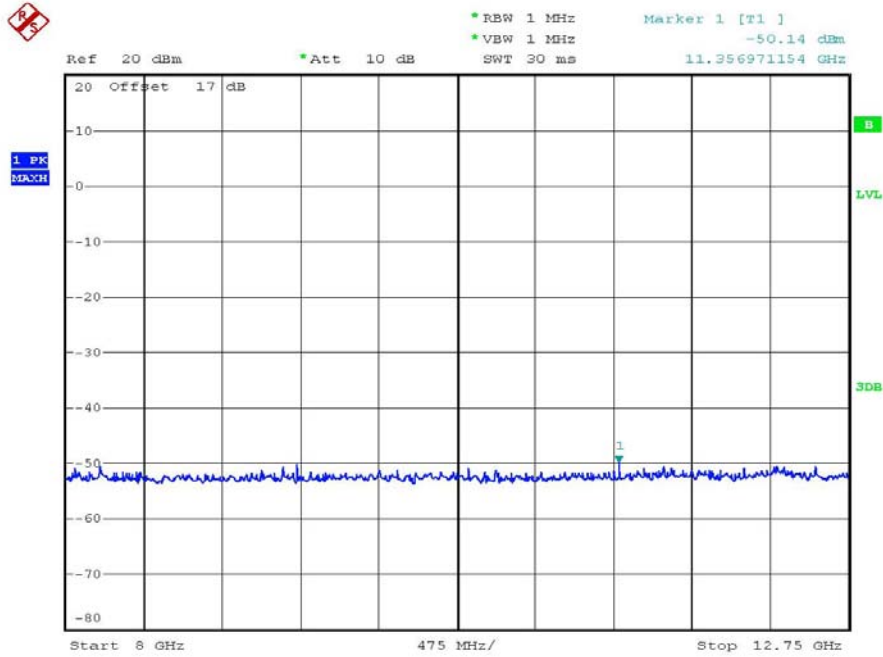

CONDUCTED SPURIOUS EMISSION WCDMA BAND II CH9262
Date: 22.APR.2017 21:28:23

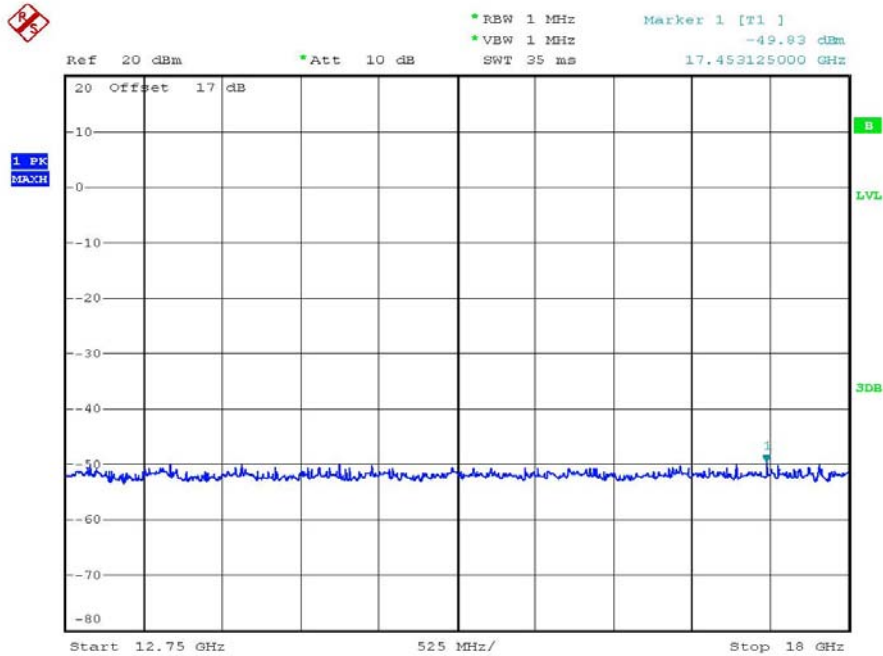

CONDUCTED SPURIOUS EMISSION WCDMA BAND II CH9262
Date: 22.APR.2017 21:30:03

Report Number: W6M21703-16710-P-2224
 FCC ID: 2ALG8RMBU3GTR

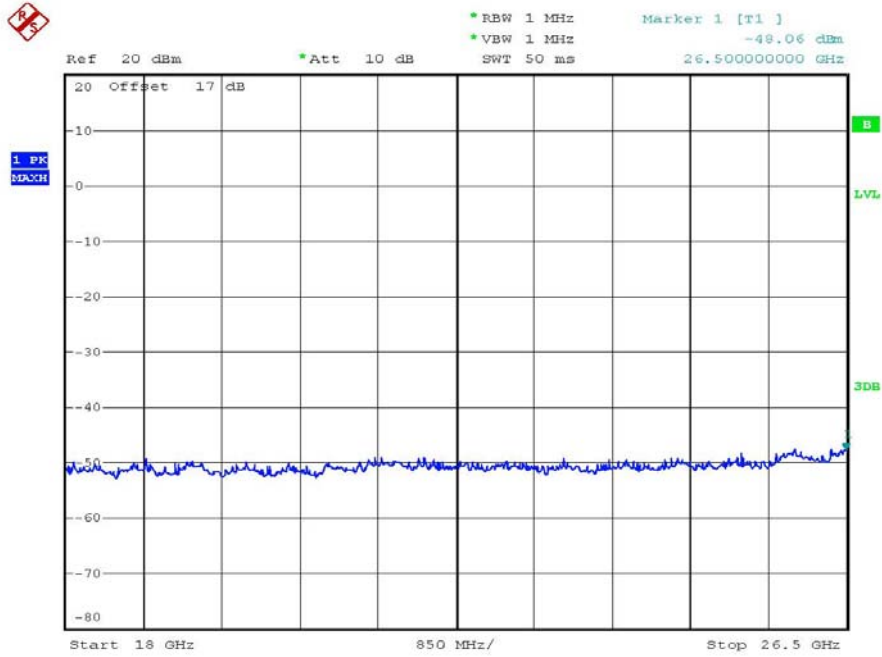

CONDUCTED SPURIOUS EMISSION WCDMA BAND II CH9262
 Date: 22.APR.2017 21:32:01

CH 9400

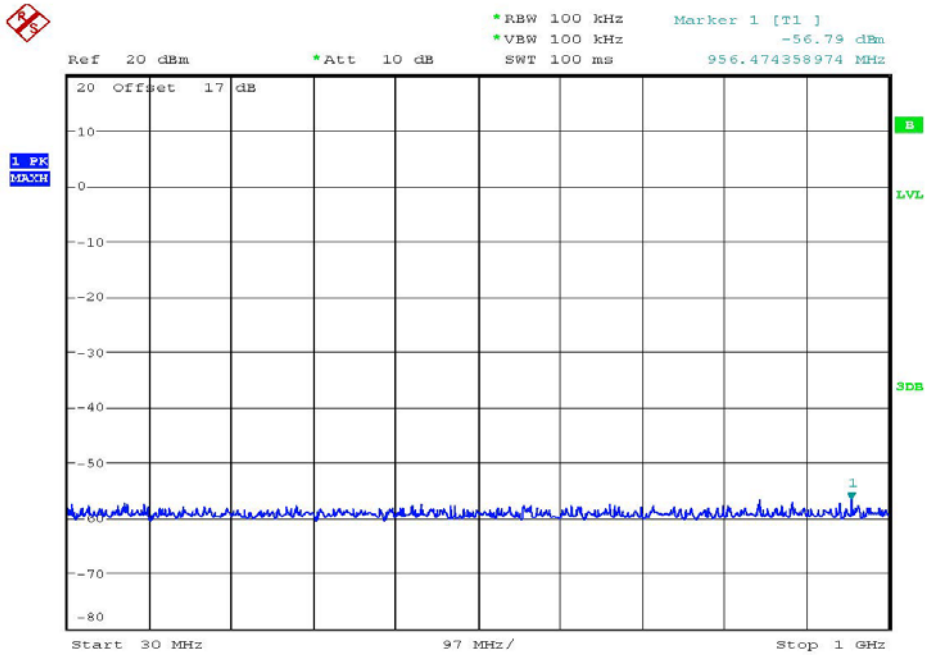

CONDUCTED SPURIOUS EMISSION WCDMA BAND II CH9400
 Date: 22.APR.2017 21:19:48

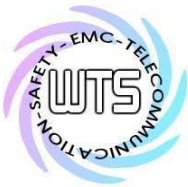

Worldwide Testing Services(Taiwan) Co., Ltd.

Report Number: W6M21703-16710-P-2224
FCC ID: 2ALG8RMBU3GTR

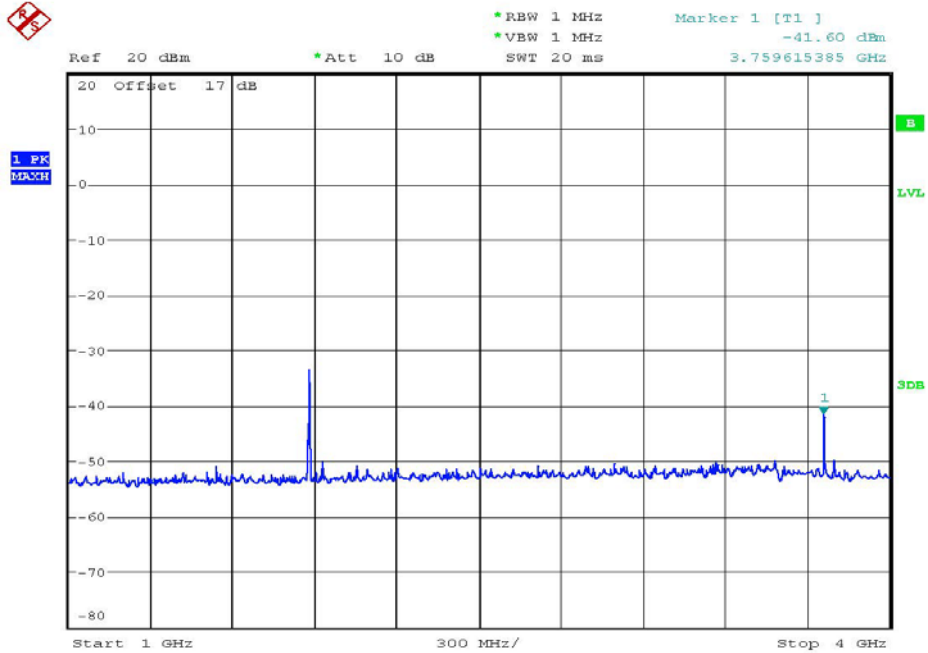

CONDUCTED SPURIOUS EMISSION WCDMA BAND II CH9400
Date: 22.APR.2017 21:23:48

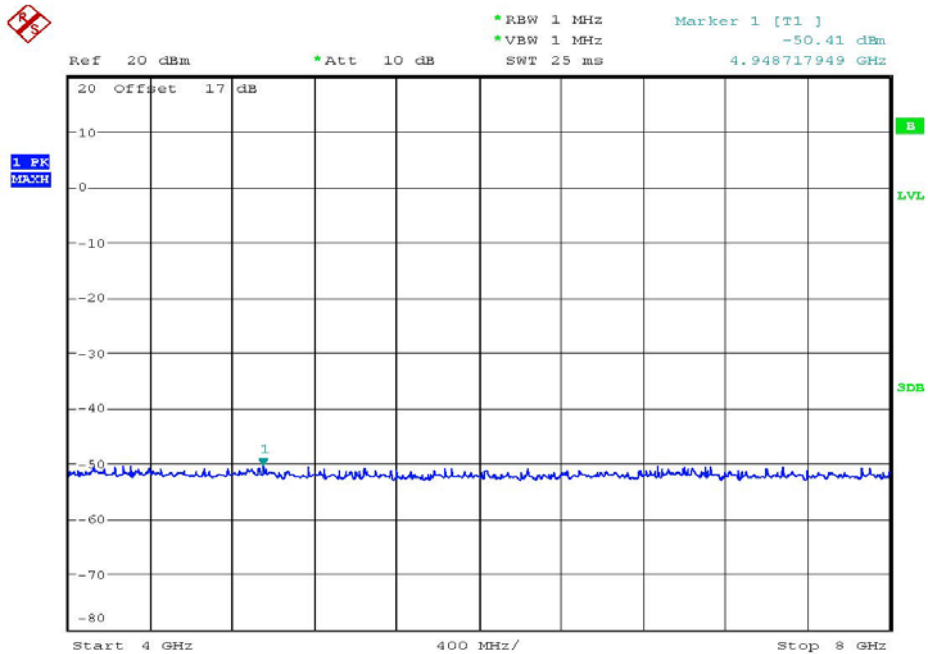

CONDUCTED SPURIOUS EMISSION WCDMA BAND II CH9400
Date: 22.APR.2017 21:26:51



Worldwide Testing Services(Taiwan) Co., Ltd.

Report Number: W6M21703-16710-P-2224
FCC ID: 2ALG8RMBU3GTR

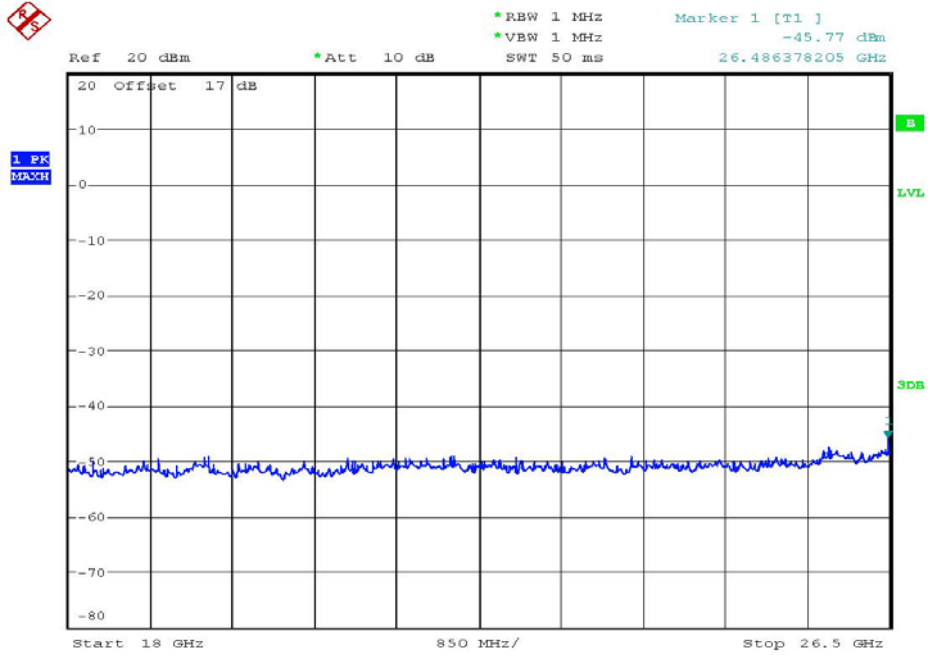

CONDUCTED SPURIOUS EMISSION WCDMA BAND II CH9400
Date: 22.APR.2017 21:31:31

CH 9538

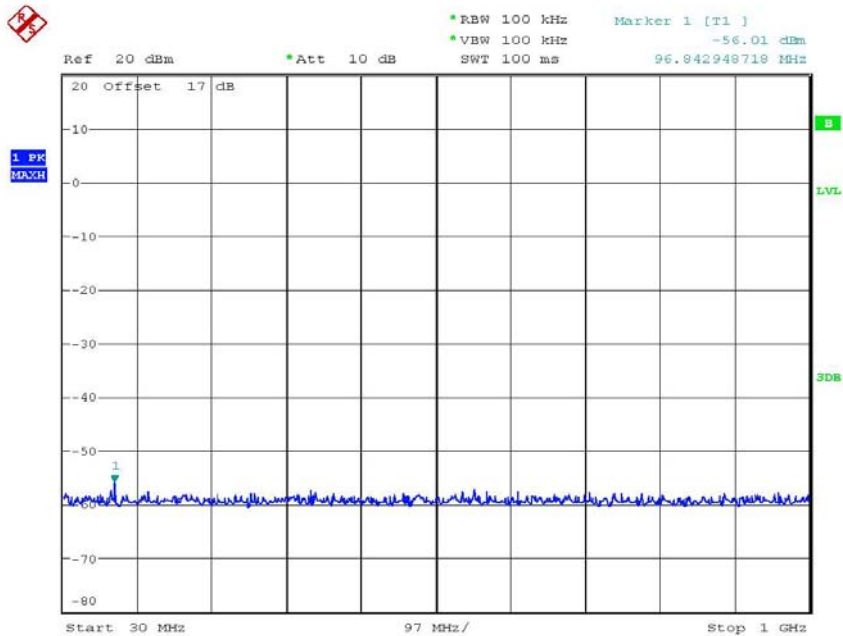

CONDUCTED SPURIOUS EMISSION WCDMA BAND II CH9538
Date: 22.APR.2017 21:20:12



Report Number: W6M21703-16710-P-2224
FCC ID: 2ALG8RMBU3GTR

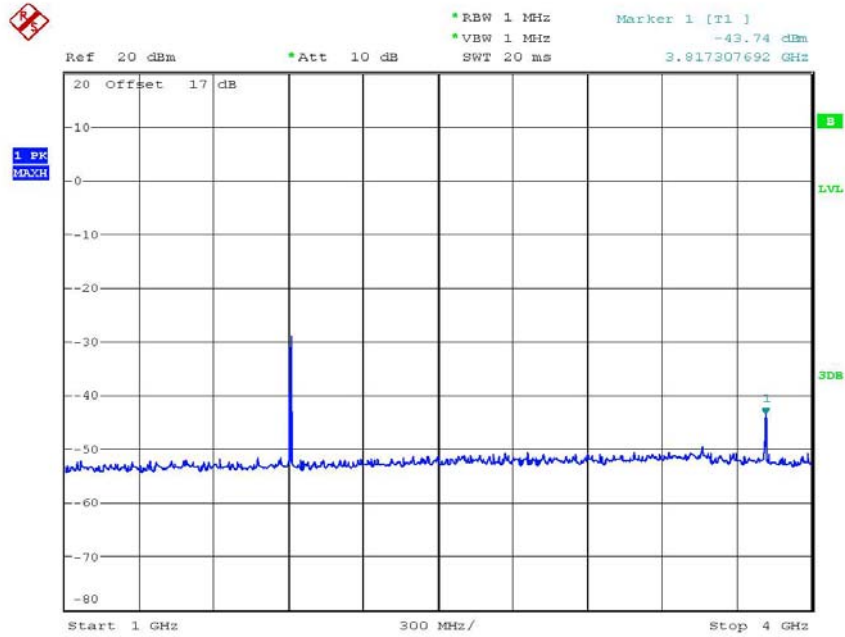

CONDUCTED SPURIOUS EMISSION WCDMA BAND II CH9538
Date: 22.APR.2017 21:22:32

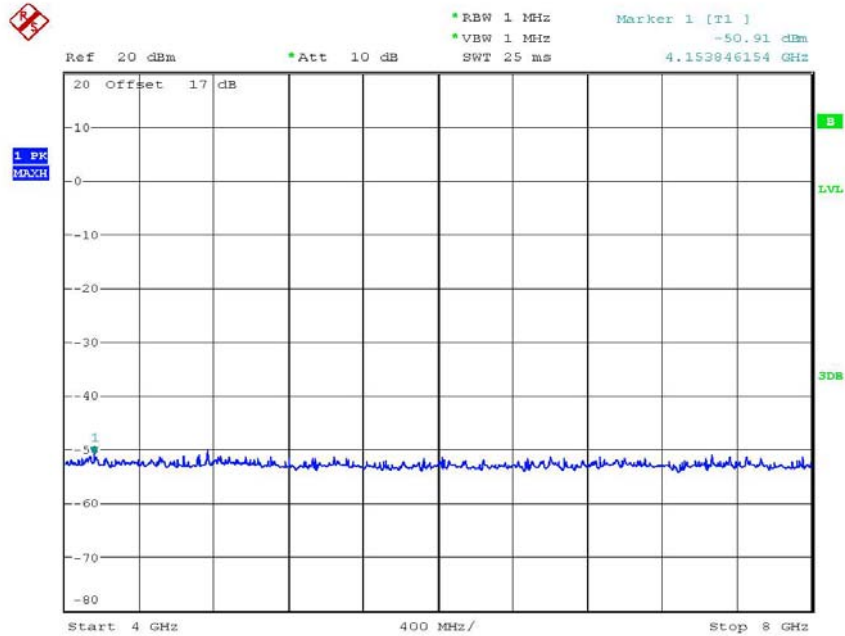

CONDUCTED SPURIOUS EMISSION WCDMA BAND II CH9538
Date: 22.APR.2017 21:27:36



Report Number: W6M21703-16710-P-2224
FCC ID: 2ALG8RMBU3GTR

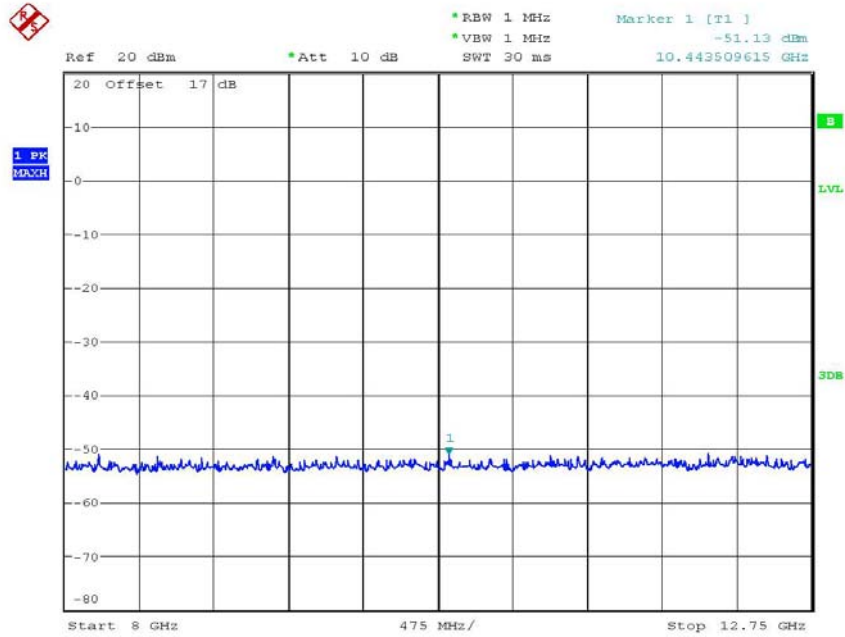

CONDUCTED SPURIOUS EMISSION WCDMA BAND II CH9538
Date: 22.APR.2017 21:27:55

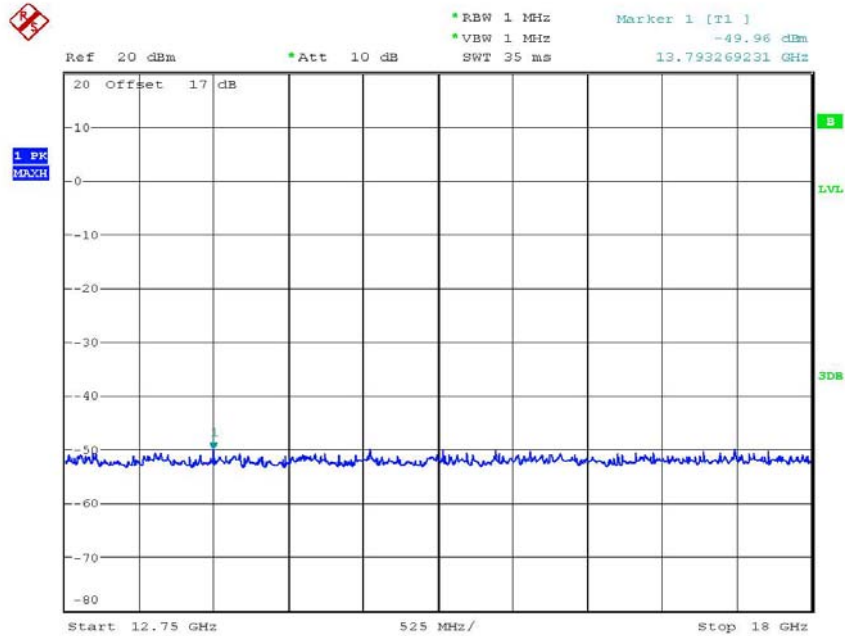

CONDUCTED SPURIOUS EMISSION WCDMA BAND II CH9538
Date: 22.APR.2017 21:30:38



Report Number: W6M21703-16710-P-2224
FCC ID: 2ALG8RMBU3GTR

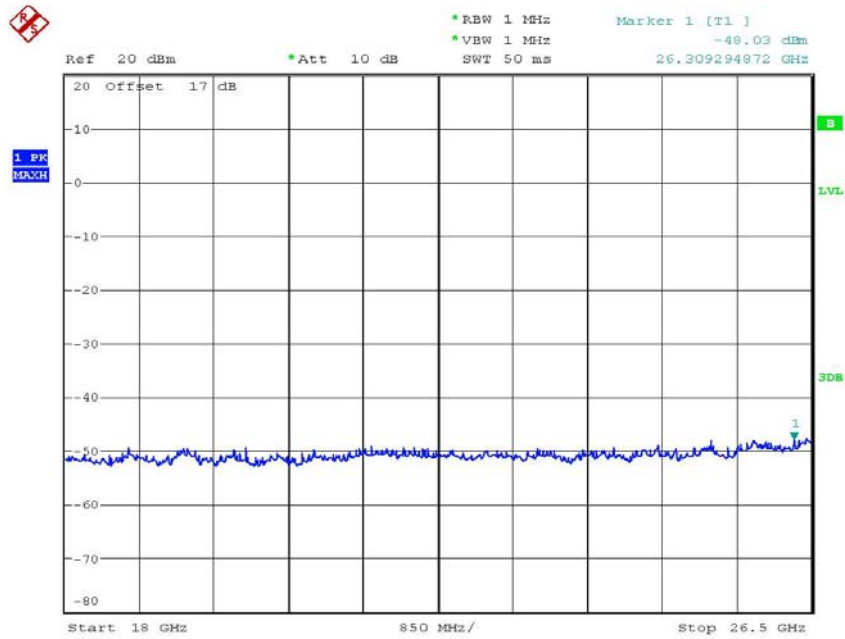

CONDUCTED SPURIOUS EMISSION WCDMA BAND II CH9538
Date: 22.APR.2017 21:31:13

Band II Idle

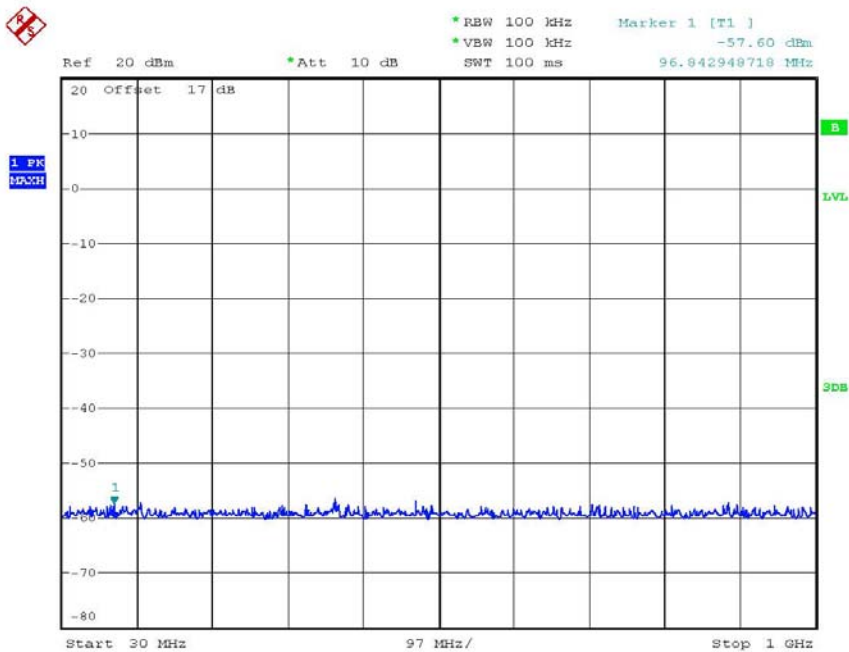

CONDUCTED SPURIOUS EMISSION WCDMA BAND II IDLE
Date: 22.APR.2017 21:20:34



Report Number: W6M21703-16710-P-2224
FCC ID: 2ALG8RMBU3GTR

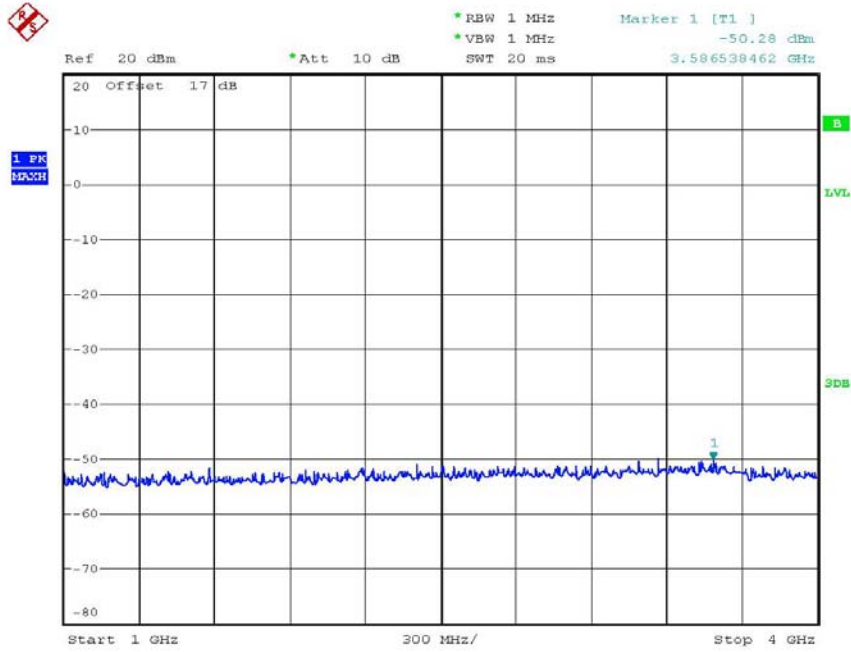

CONDUCTED SPURIOUS EMISSION WCDMA BAND II IDLE
Date: 22.APR.2017 21:24:29

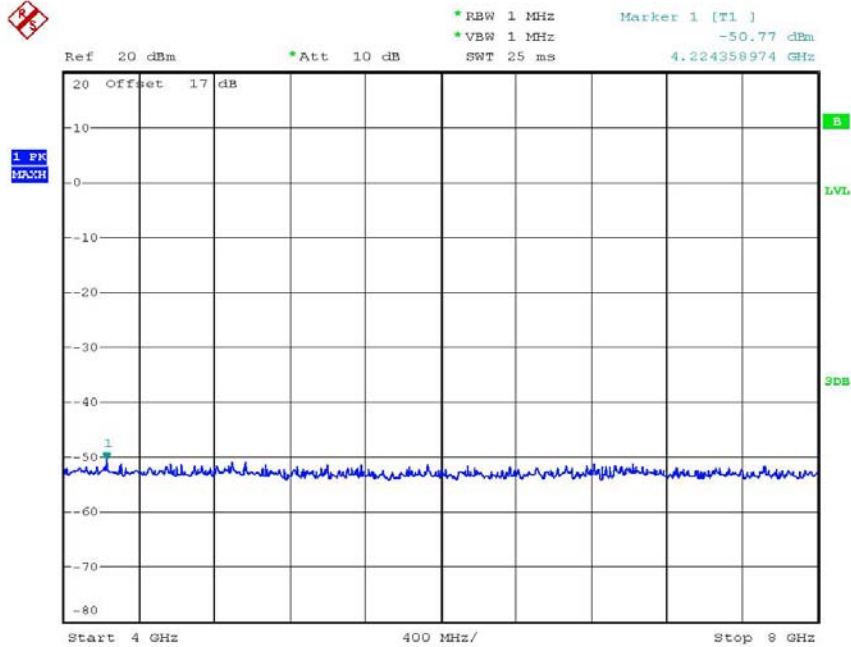

CONDUCTED SPURIOUS EMISSION WCDMA BAND II IDLE
Date: 22.APR.2017 21:24:50



Worldwide Testing Services(Taiwan) Co., Ltd.

Report Number: W6M21703-16710-P-2224
FCC ID: 2ALG8RMBU3GTR

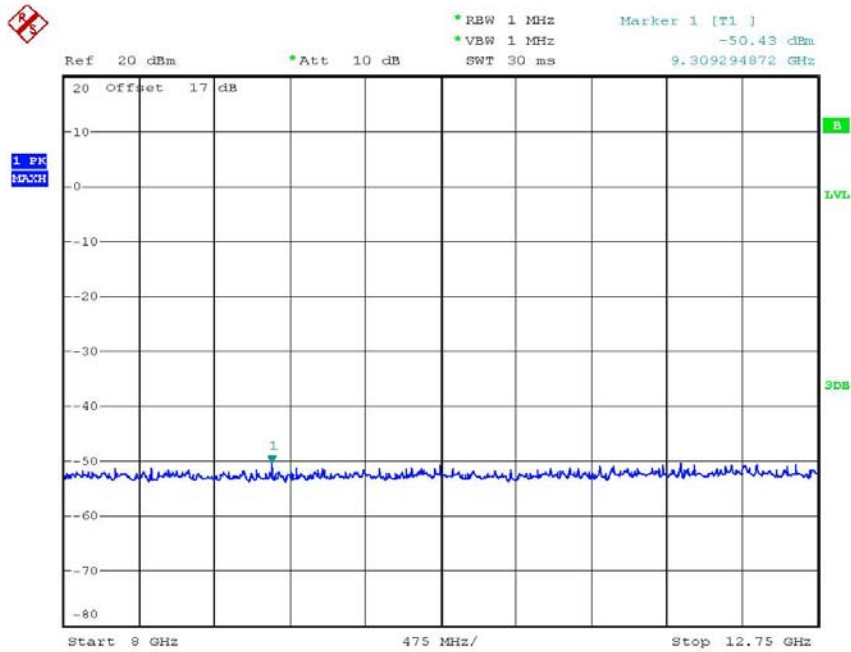

CONDUCTED SPURIOUS EMISSION WCDMA BAND II IDLE
Date: 22.APR.2017 21:29:16

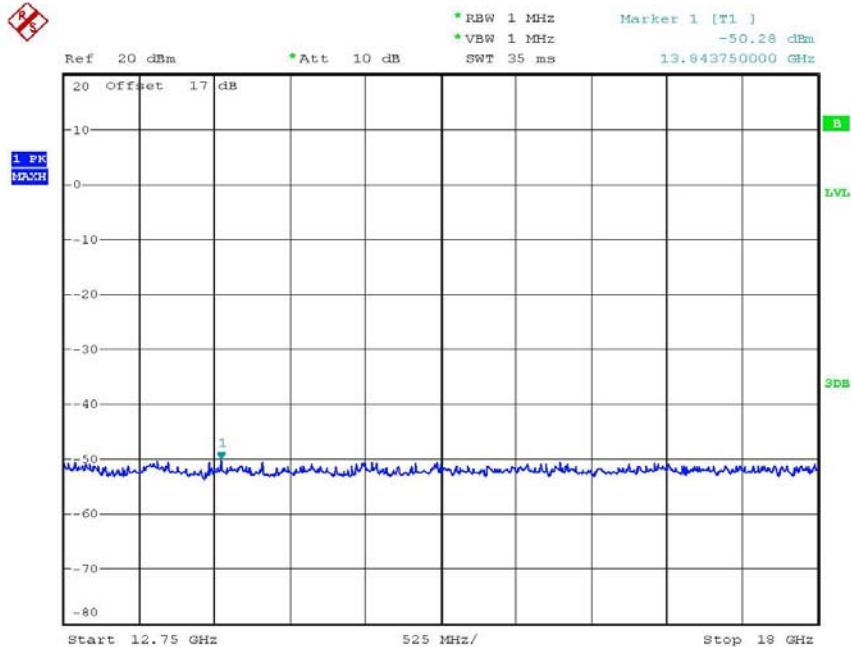

CONDUCTED SPURIOUS EMISSION WCDMA BAND II IDLE
Date: 22.APR.2017 21:29:41



Report Number: W6M21703-16710-P-2224
FCC ID: 2ALG8RMBU3GTR

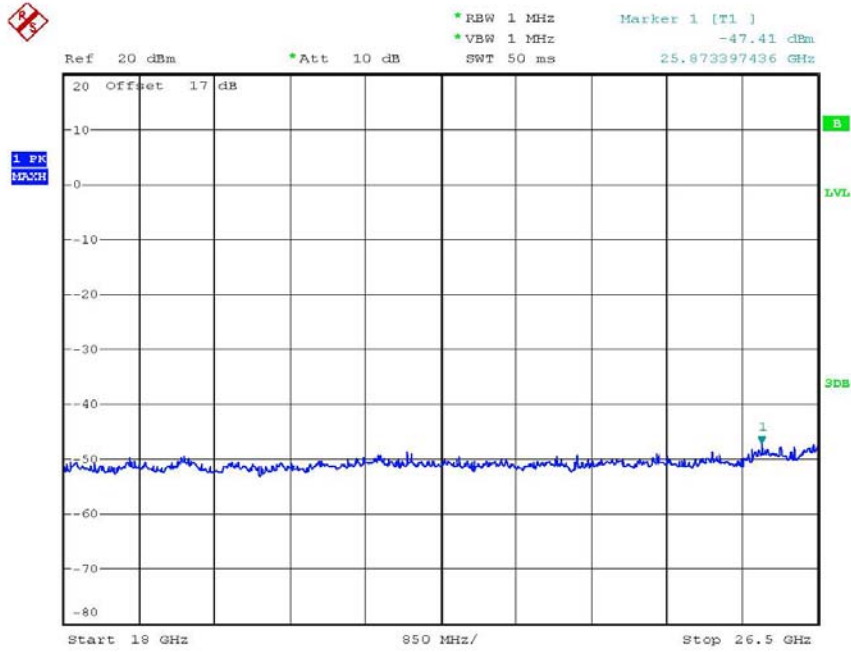

CONDUCTED SPURIOUS EMISSION WCDMA BAND II IDLE
Date: 22.APR.2017 21:32:21

Band V
CH 4132

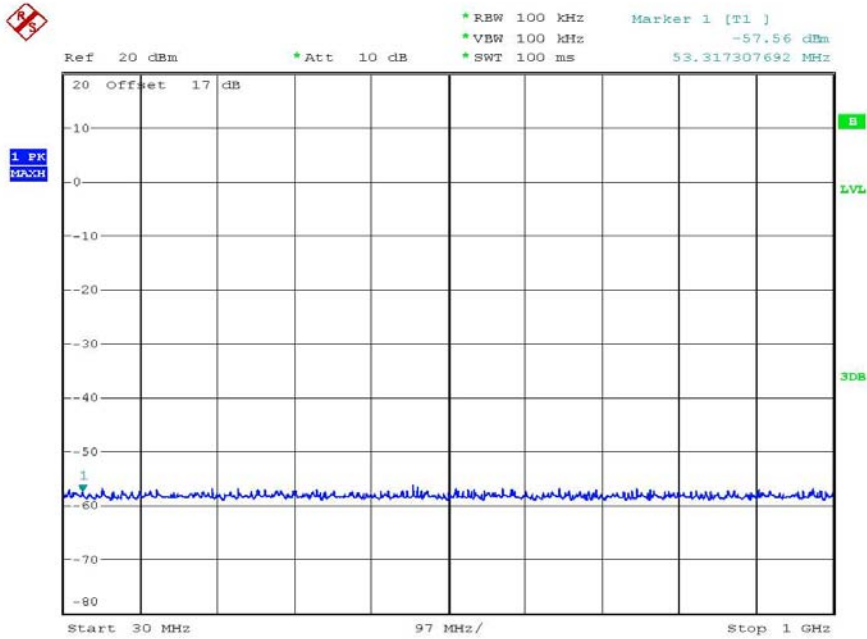

CONDUCTED SPURIOUS EMISSION WCDMA BAND V CH4132
Date: 22.APR.2017 19:52:35



Report Number: W6M21703-16710-P-2224
FCC ID: 2ALG8RMBU3GTR

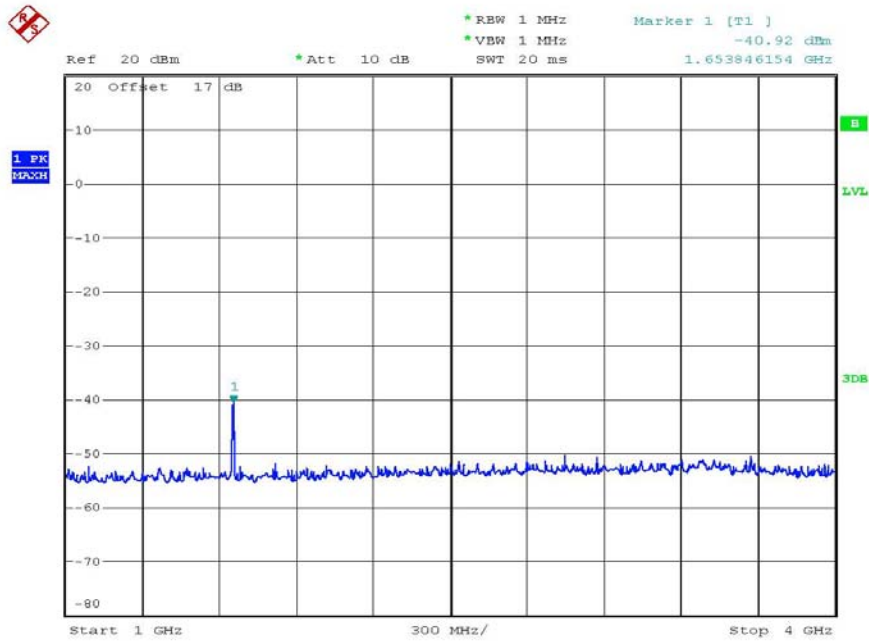

CONDUCTED SPURIOUS EMISSION WCDMA BAND V CH4132
Date: 22.APR.2017 21:16:31

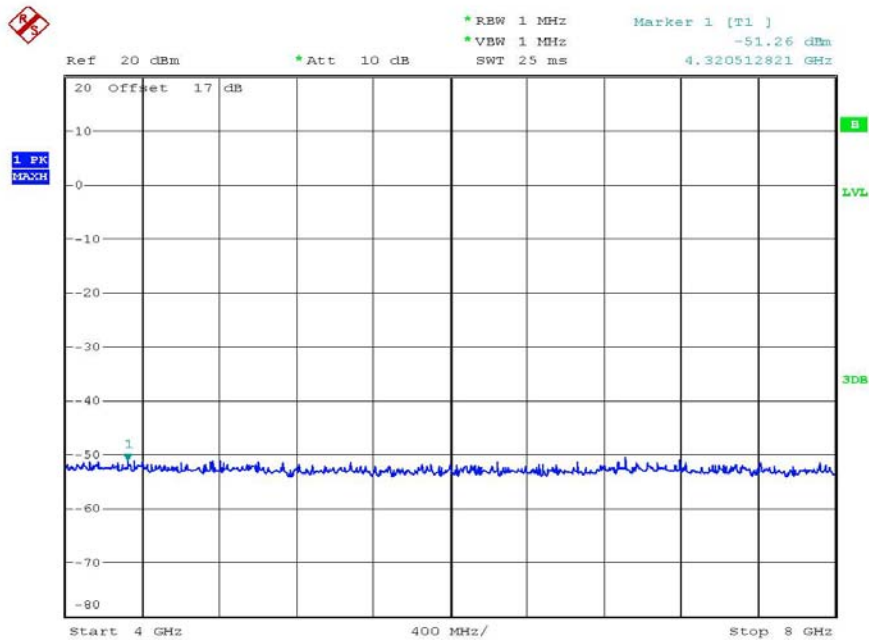

CONDUCTED SPURIOUS EMISSION WCDMA BAND V CH4132
Date: 22.APR.2017 20:01:33



Report Number: W6M21703-16710-P-2224
FCC ID: 2ALG8RMBU3GTR

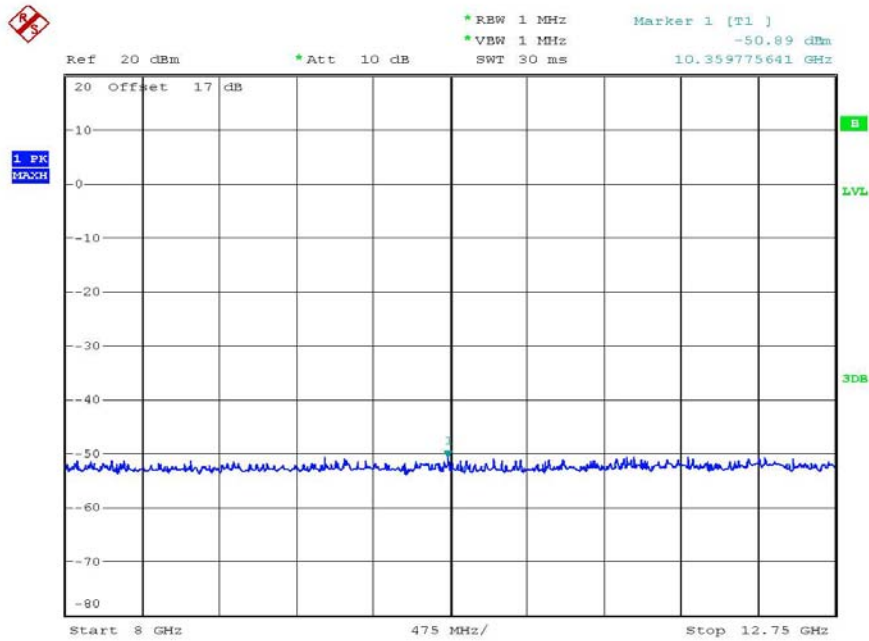

CONDUCTED SPURIOUS EMISSION WCDMA BAND V CH4132
Date: 22.APR.2017 20:02:51

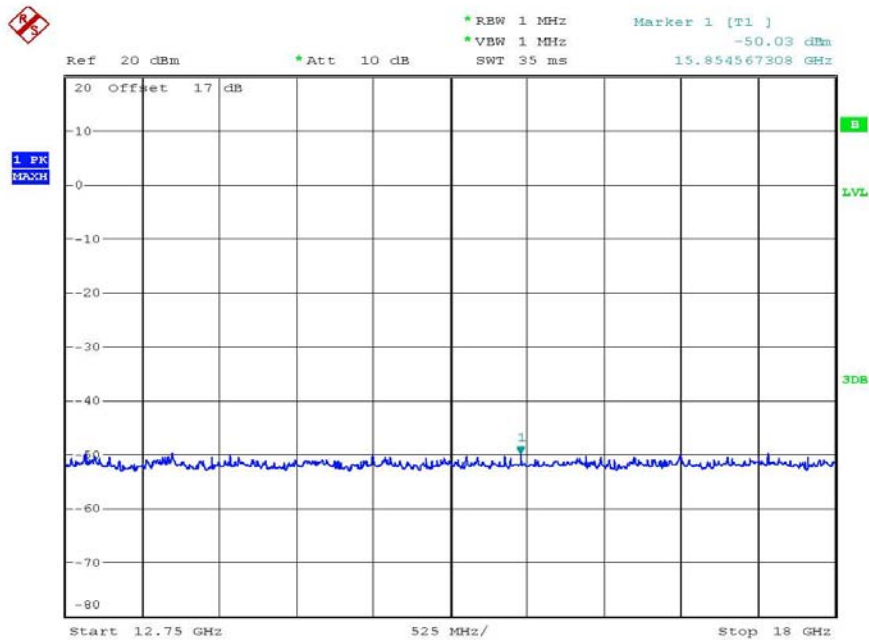

CONDUCTED SPURIOUS EMISSION WCDMA BAND V CH4132
Date: 22.APR.2017 20:45:40



Report Number: W6M21703-16710-P-2224
FCC ID: 2ALG8RMBU3GTR

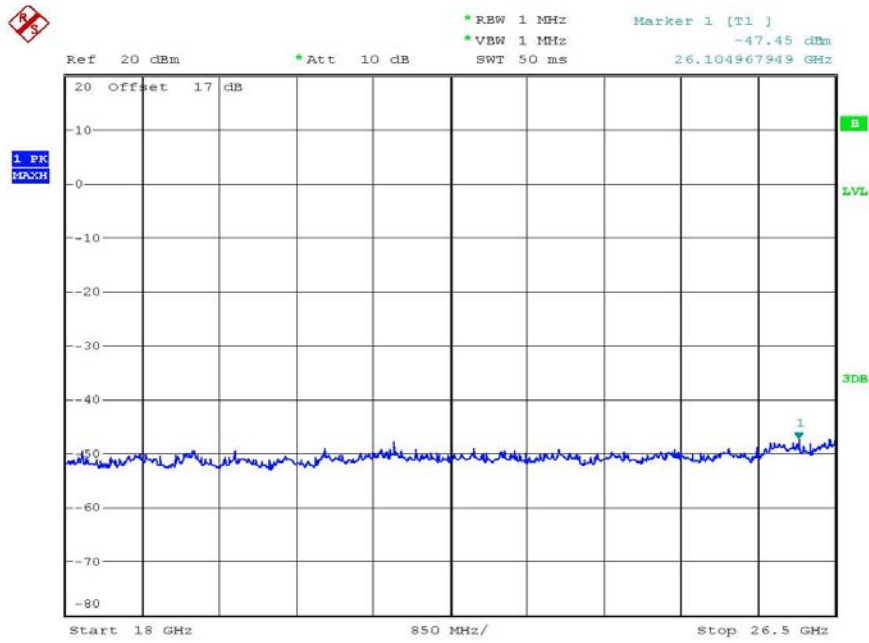

CONDUCTED SPURIOUS EMISSION WCDMA BAND V CH4132
Date: 22.APR.2017 20:48:10

CH 4183

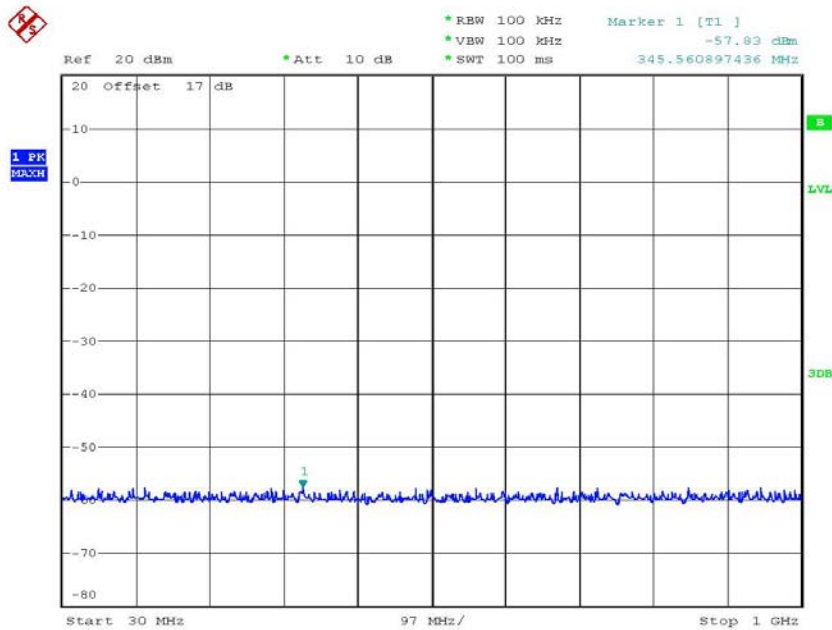

CONDUCTED SPURIOUS EMISSION WCDMA BAND V CH4183
Date: 22.APR.2017 19:53:23



Worldwide Testing Services(Taiwan) Co., Ltd.

Report Number: W6M21703-16710-P-2224
FCC ID: 2ALG8RMBU3GTR

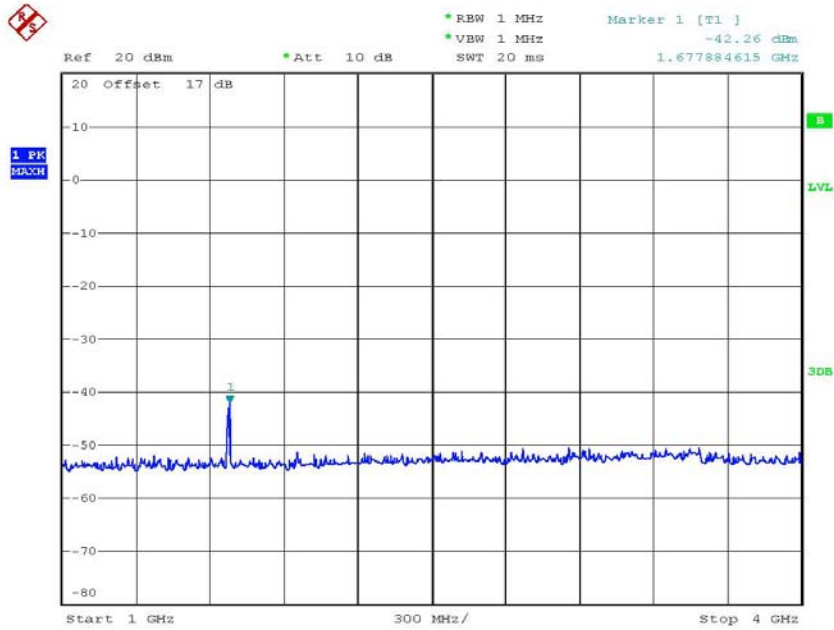

CONDUCTED SPURIOUS EMISSION WCDMA BAND V CH4183
Date: 22.APR.2017 20:00:17

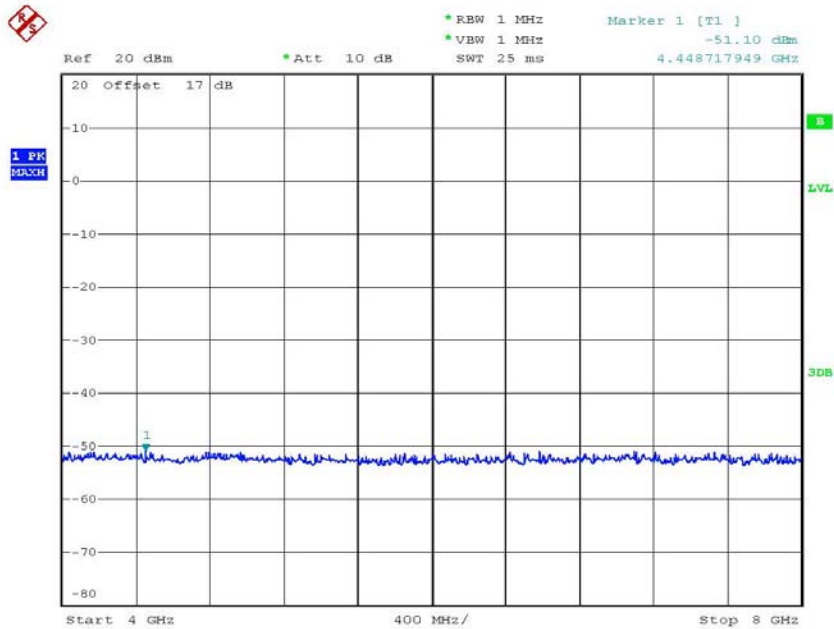

CONDUCTED SPURIOUS EMISSION WCDMA BAND V CH4183
Date: 22.APR.2017 20:01:02



Report Number: W6M21703-16710-P-2224
FCC ID: 2ALG8RMBU3GTR

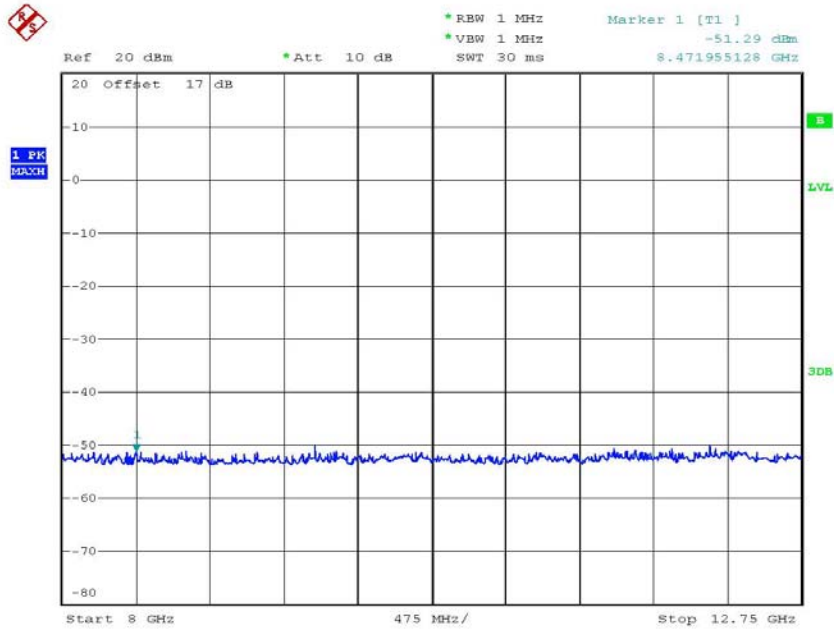

CONDUCTED SPURIOUS EMISSION WCDMA BAND V CH4183
Date: 22.APR.2017 20:03:11

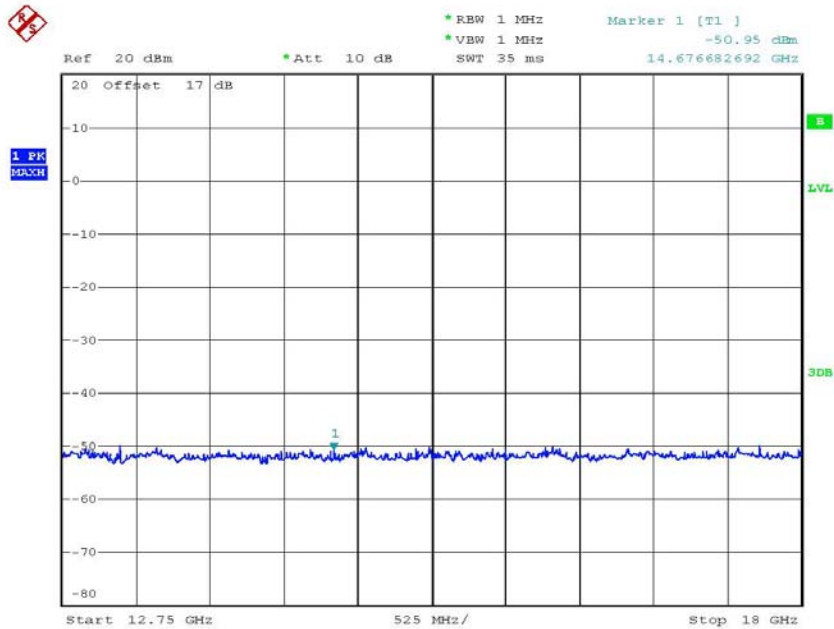

CONDUCTED SPURIOUS EMISSION WCDMA BAND V CH4183
Date: 22.APR.2017 20:46:09



Report Number: W6M21703-16710-P-2224
FCC ID: 2ALG8RMBU3GTR

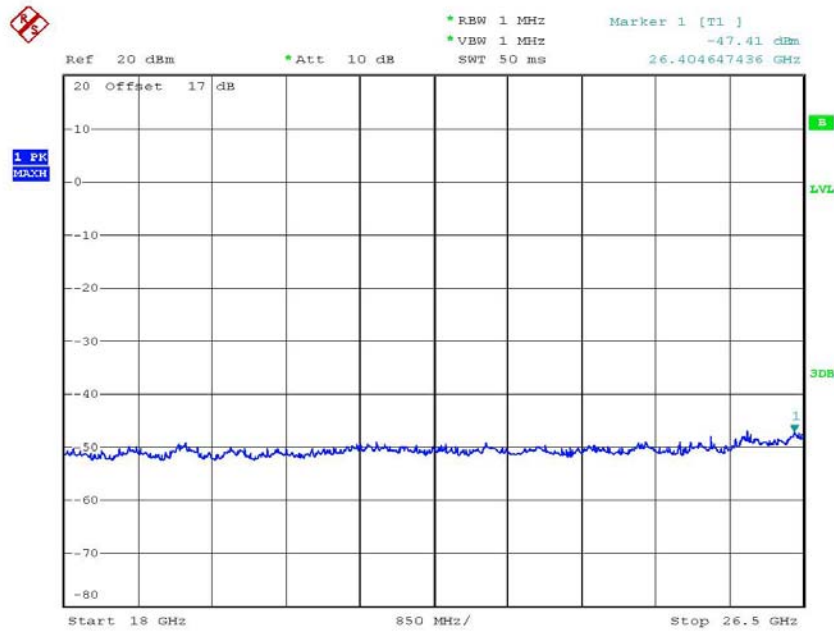

CONDUCTED SPURIOUS EMISSION WCDMA BAND V CH4183
Date: 22.APR.2017 20:47:48

CH 4233

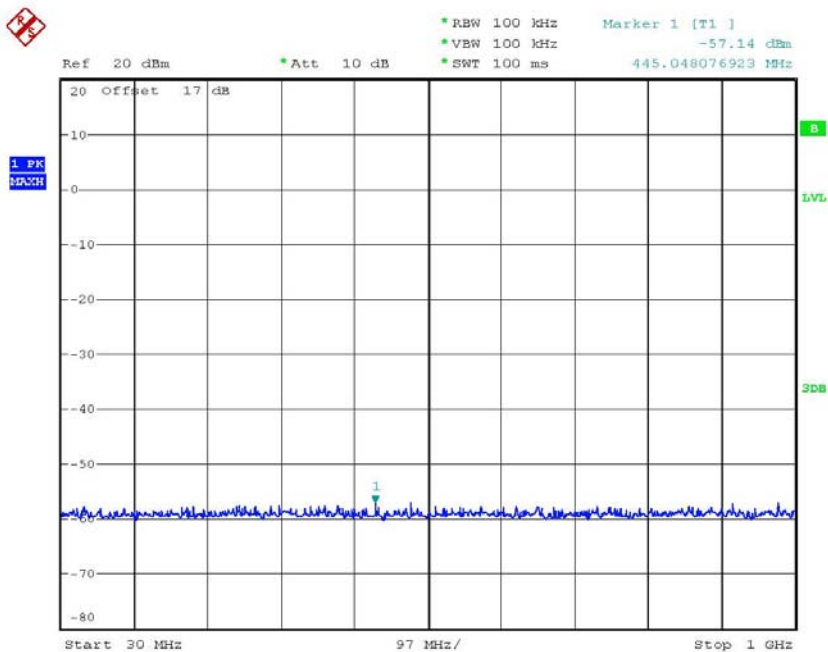

CONDUCTED SPURIOUS EMISSION WCDMA BAND V CH4233
Date: 22.APR.2017 19:53:55



Report Number: W6M21703-16710-P-2224
FCC ID: 2ALG8RMBU3GTR

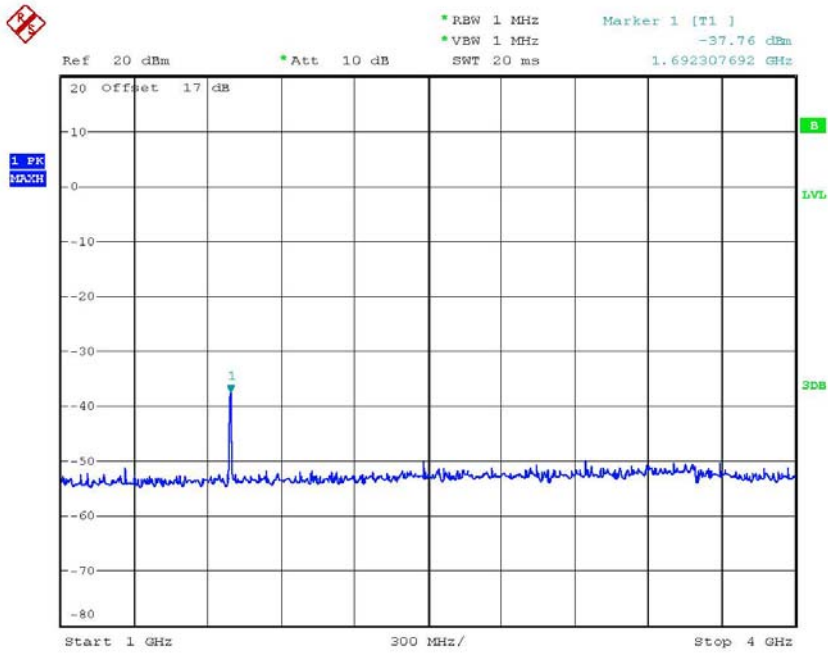

CONDUCTED SPURIOUS EMISSION WCDMA BAND V CH4233
Date: 22.APR.2017 19:58:26

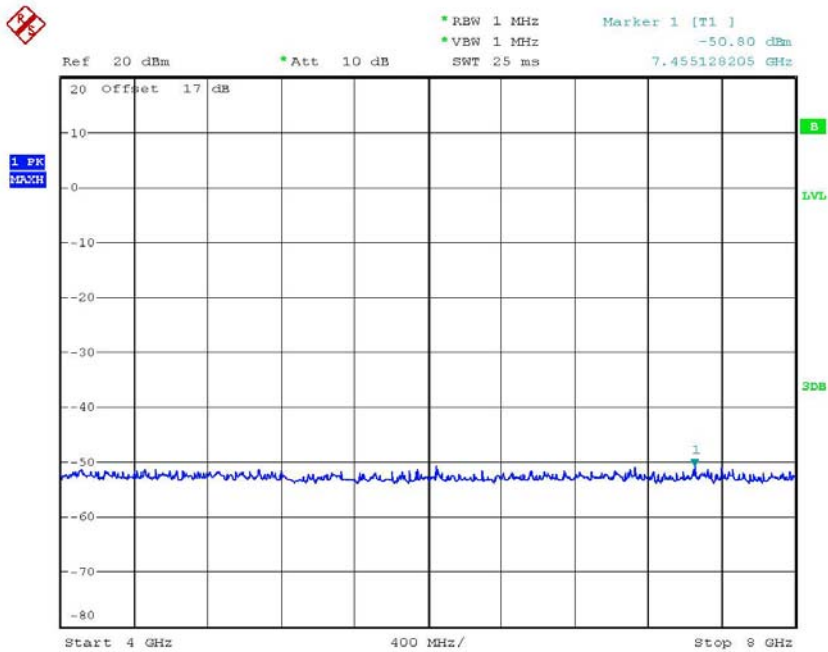

CONDUCTED SPURIOUS EMISSION WCDMA BAND V CH4233
Date: 22.APR.2017 20:01:56



Report Number: W6M21703-16710-P-2224
FCC ID: 2ALG8RMBU3GTR

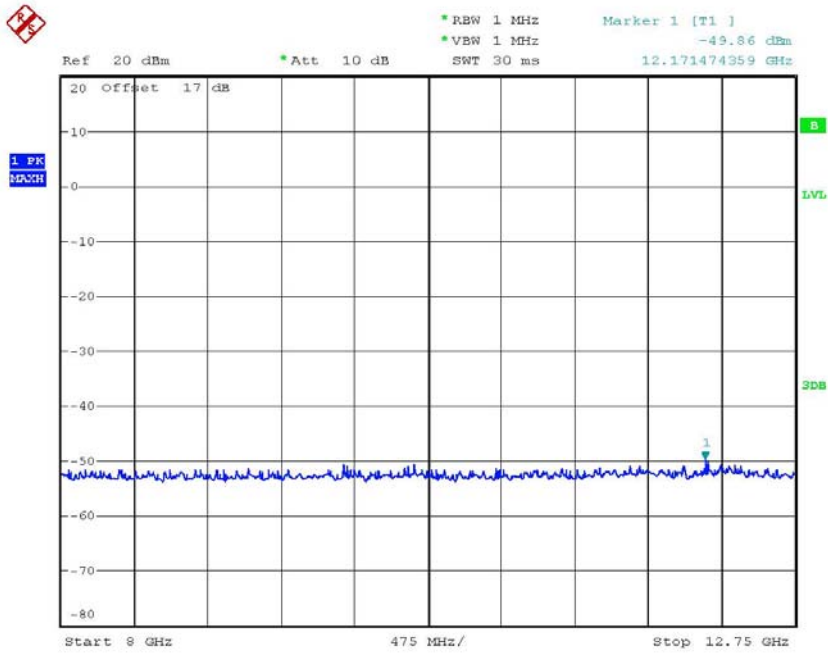

CONDUCTED SPURIOUS EMISSION WCDMA BAND V CH4233
Date: 22.APR.2017 20:02:26

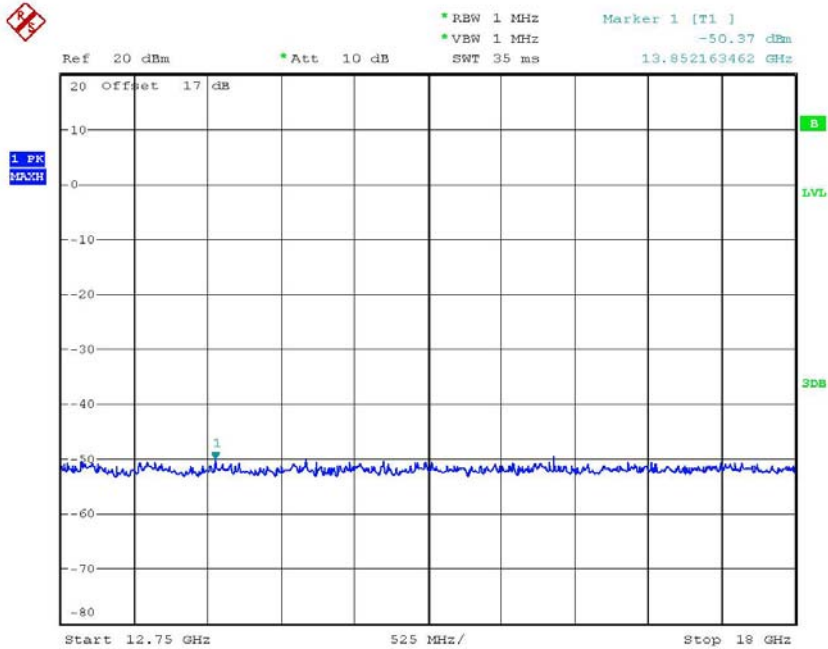

CONDUCTED SPURIOUS EMISSION WCDMA BAND V CH4233
Date: 22.APR.2017 20:46:36



Report Number: W6M21703-16710-P-2224
FCC ID: 2ALG8RMBU3GTR

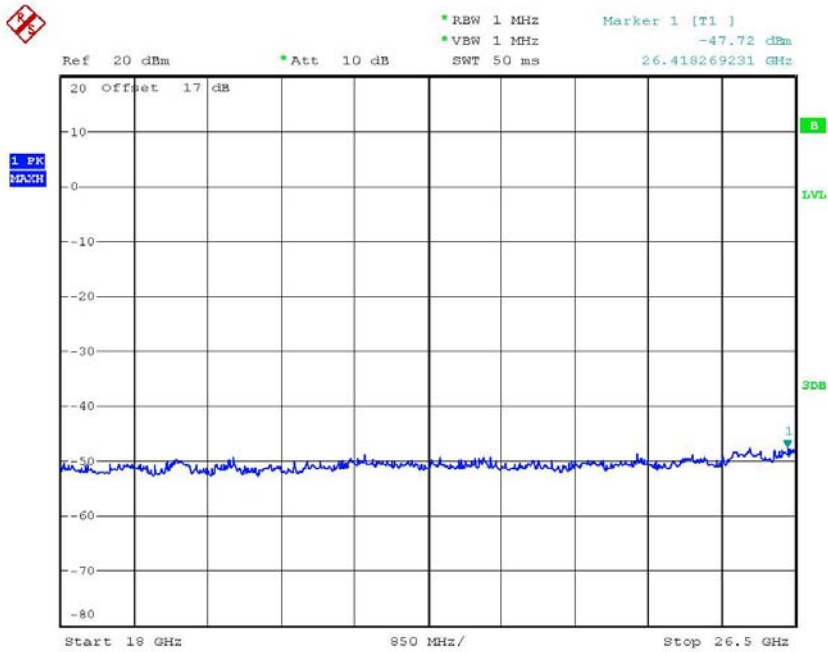

CONDUCTED SPURIOUS EMISSION WCDMA BAND V CH4233
Date: 22.APR.2017 20:47:15

Band V Idle

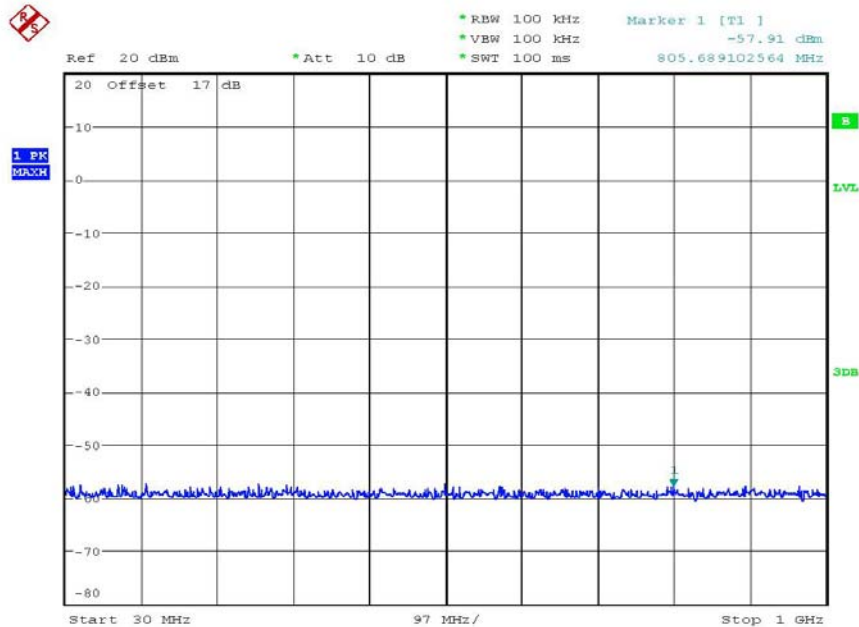

CONDUCTED SPURIOUS EMISSION WCDMA BAND V IDLE
Date: 22.APR.2017 19:54:26



Worldwide Testing Services(Taiwan) Co., Ltd.

Report Number: W6M21703-16710-P-2224
FCC ID: 2ALG8RMBU3GTR

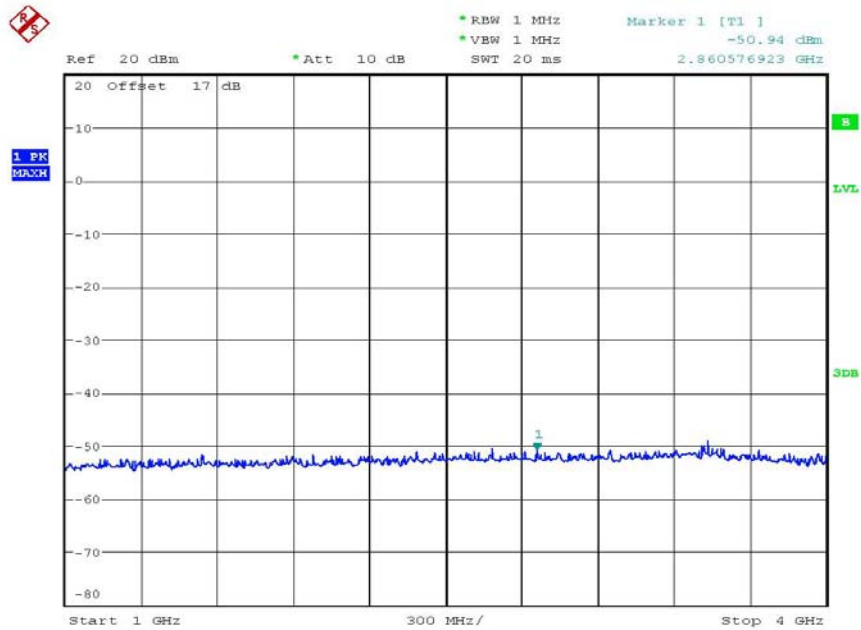

CONDUCTED SPURIOUS EMISSION WCDMA BAND V IDLE
Date: 22.APR.2017 21:12:45

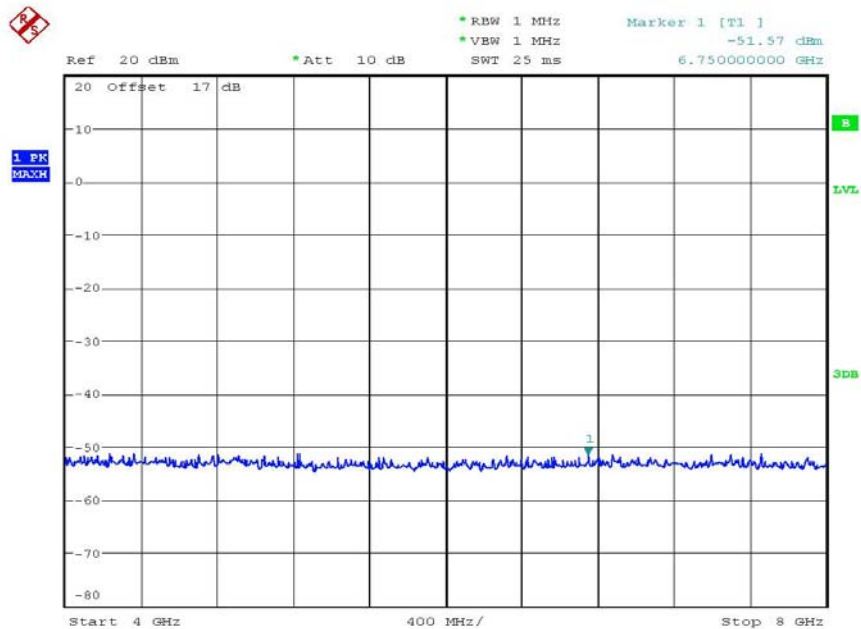

CONDUCTED SPURIOUS EMISSION WCDMA BAND V IDLE
Date: 22.APR.2017 21:13:01



Worldwide Testing Services(Taiwan) Co., Ltd.

Report Number: W6M21703-16710-P-2224
FCC ID: 2ALG8RMBU3GTR

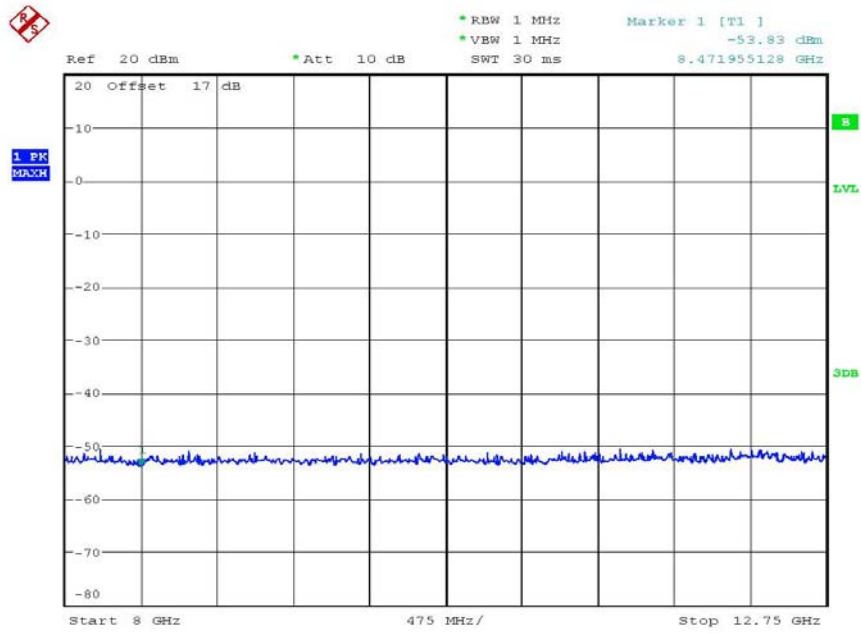

CONDUCTED SPURIOUS EMISSION WCDMA BAND V IDLE
Date: 22.APR.2017 20:03:36

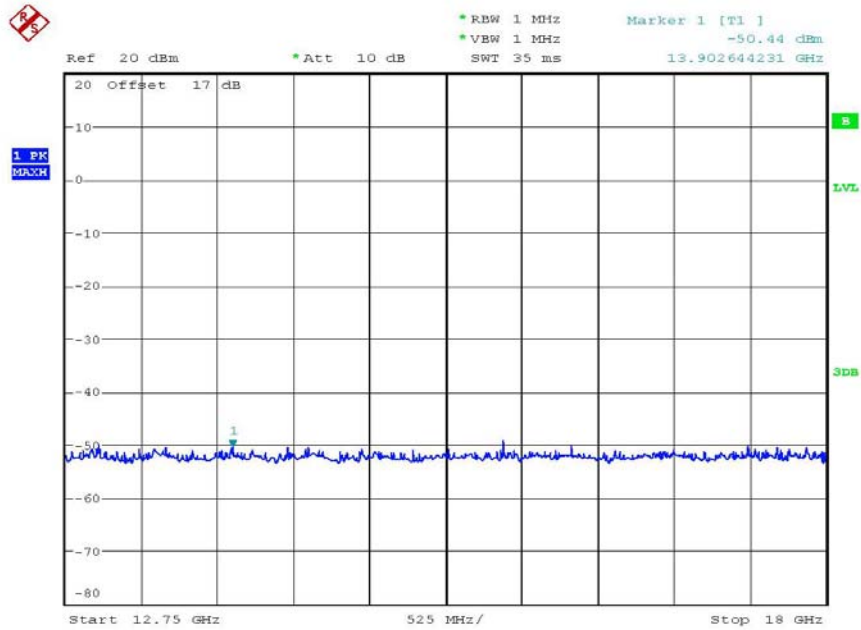

CONDUCTED SPURIOUS EMISSION WCDMA BAND V IDLE
Date: 22.APR.2017 20:04:02



Report Number: W6M21703-16710-P-2224
FCC ID: 2ALG8RMBU3GTR

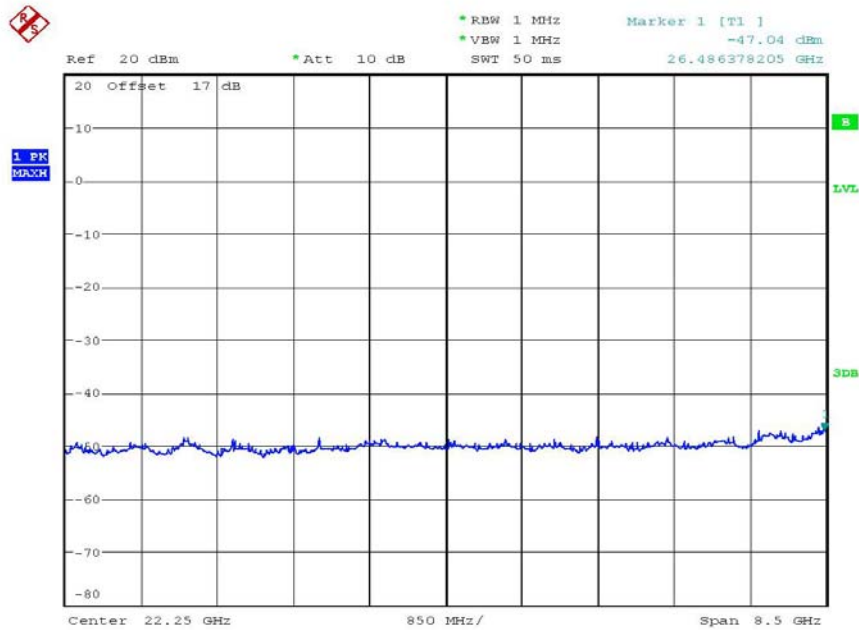

CONDUCTED SPURIOUS EMISSION WCDMA BAND V IDLE
Date: 22.APR.2017 20:55:49

Test equipment: ETSTW-RE 055, ETSTW-GSM 002

6.3 Explanation of test result

All factors like cable loss and external attenuation etc. are already included in the provided measurement results. This is done by using validated test software and calibrated test system according to the accreditation requirements.

6.4 Calculation of Limit for Spurious at Antenna Terminals

Compliance with § 22.917(a) requires that any emission be attenuated below the transmitter power at least $43 + 10 \log P$ (P = transmitter power in Watts).

Limit for Spurious Emissions at Antenna Terminals: $L=P-A=-13\text{dBm}$

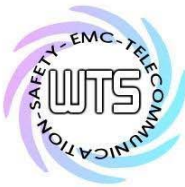

Report Number: W6M21703-16710-P-2224

FCC ID: 2ALG8RMBU3GTR

7. Field Strength of Spurious Radiation

7.1 Test procedure

The test procedure for filed strength measurement is same as radiated power except for a notch filter or band pass filter is used to avoid the influence of fundamental to the pre-amplifier. The measurements below 1GHz were performed with a measurement bandwidth of 100kHz, above 1GHz with a bandwidth of 1 MHz.

7.2 Test Results

The measurements of the spurious emission are at the upper, center and lower channel.

Model: RMBU_3GTR Date: --
 Mode: -- Temperature: -- °C Engineer: --
 Polarization: Horizontal Humidity: -- %

Frequency (MHz)	Reading (dBm) Peak	Factor (dB) Corr.	Result (dBm)	Limit (dBm)	Margin (dB)	Table Degree (Deg.)	Ant. High (cm)
--	--	--	--	--	--	--	--
--	--	--	--	--	--	--	--

Polarization: Vertical

Frequency (MHz)	Reading (dBm) Peak	Factor (dB) Corr.	Result (dBm)	Limit (dBm)	Margin (dB)	Table Degree (Deg.)	Ant. High (cm)
--	--	--	--	--	--	--	--
--	--	--	--	--	--	--	--

- Note**
1. Correction Factor = Antenna factor + Cable loss - Preamplifier
 2. The formula of measured value as: Test Result = Reading + Correction Factor
 3. Detector function in the form : PK = Peak, QP = Quasi Peak, AV = Average
 4. All not in the table noted test results are more than 20 dB below the relevant limits.
 5. Measurement uncertainty 30-1000 MHz = ±3.30 dB, 1-18 GHz = ± 2.28 dB, 18-40 GHz = ± 2.19 dB ; Reported uncertainties represent expanded uncertainties expressed at approximately the 95% confidence level using a coverage factor of k = 2.
 6. See attached diagrams in appendix.

7.3 Explanation of test result

Result Level = Reading Level + Corrected Factor

Corrected Factor = SG level – Received level-Cable loss + substitution antenna gain

7.4 Calculation of Limit for Field Strength of Spurious

Compliance with § 24.238(a) requires that any emission be attenuated below the transmitter power at least $43 + 10 \log P$ (P = transmitter power in Watts).

Limit for Spurious Emissions at Antenna Terminals: $L=P-A=-13\text{dBm}$

Test equipment: ETSTW-RE 004, ETSTW-RE 018, ETSTW-RE 030, ETSTW-RE 062, ETSTW-RE 142, ETSTW-RE 147, ETSTW-GSM 002



Report Number: W6M21703-16710-P-2224

FCC ID: 2ALG8RMBU3GTR

7.5 Test result of band edge emissions

Band 850 MHz

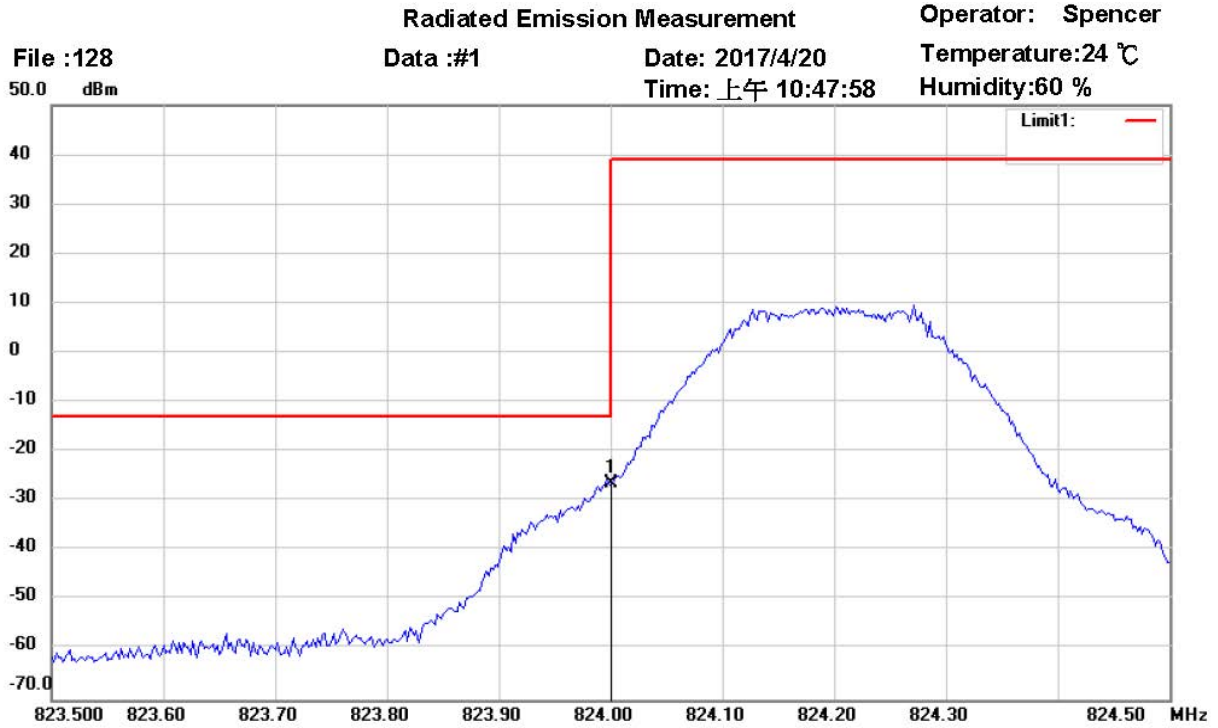

Site : Chamber

Condition : FCC_part 22 Bandedge

EUT : W6M21703-16710

M/N:

Test Mode : GSM850 CH128 BANDEDGE

Note :

Polarization: *Horizontal*

Power : 3.7V d.c.

Distance: 3m

Mk.	Frequency (MHz)	Reading (dBm)	Detector	Corr. factor (dB)	Result (dBm)	Limit (dBm)	Ant.Pos (cm)	Tab.Pos (deg.)	Margin (dB)	Comment
*	824.0000	-62.12	peak	35.63	-26.49	-13.00	150	10	-13.49	



Worldwide Testing Services(Taiwan) Co., Ltd.

Report Number: W6M21703-16710-P-2224
 FCC ID: 2ALG8RMBU3GTR

Radiated Emission Measurement

Operator: Spencer

File :128
 50.0 dBm

Data :#2

Date: 2017/4/20

Temperature:24 °C

Time: 上午 10:56:53

Humidity:60 %

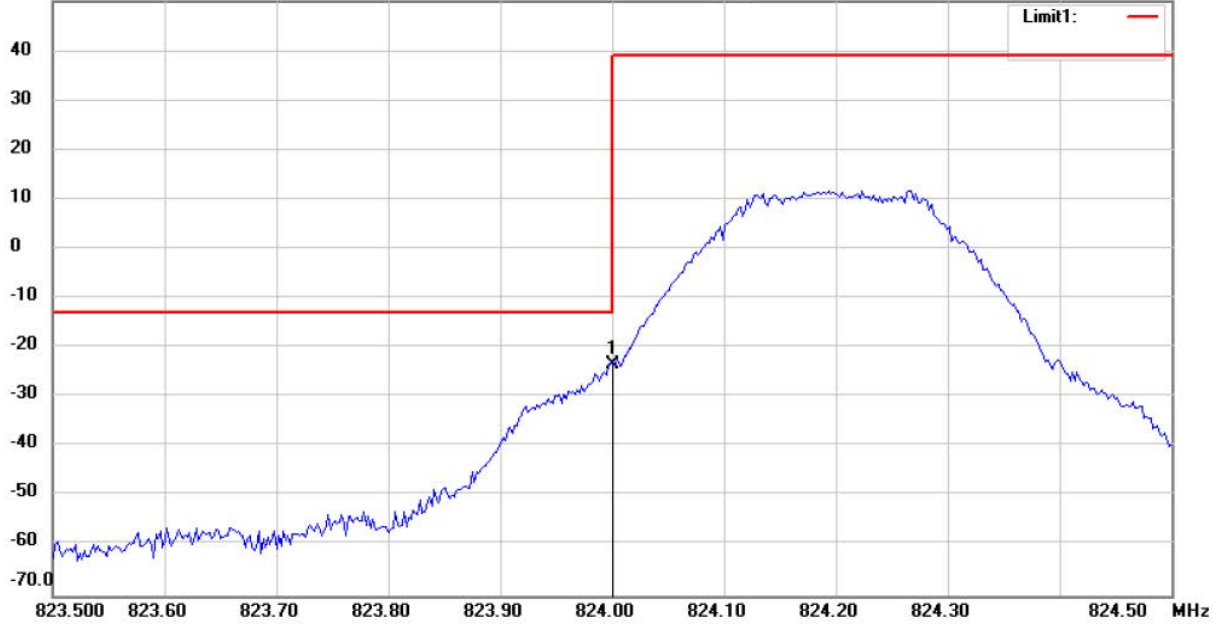

Site : Chamber

Condition : FCC_part 22 Bandedge

Polarization: *Vertical*

EUT : W6M21703-16710

Power : 3.7V d.c.

M/N:

Distance: 3m

Test Mode : GSM850 CH128 BANDEDGE

Note :

Mk.	Frequency (MHz)	Reading (dBm)	Detector	Corr. factor (dB)	Result (dBm)	Limit (dBm)	Ant.Pos (cm)	Tab.Pos (deg.)	Margin (dB)	Comment
*	824.0000	-58.89	peak	35.56	-23.33	-13.00	150	240	-10.33	