

FCC RADIO TEST REPORT

FCC 47 CFR PART 15 SUBPART C

Test Standard	FCC Part 15.231
FCC ID	2ALECSENSE100
Trade name	Buddy
Product name	Ohm Sense 100
Model No.	Ohm Sense 100
Operation Freq.	434.00MHz
Test Result	Pass

The test Result was tested by Compliance Certification Services Inc. The test data, data evaluation, test procedures, and equipment configurations shown in this report were given in ANSI C63.10: 2013 and compliance standards.

The test results of this report relate only to the tested sample (EUT) identified in this report.

The test Report of full or partial shall not copy. Without written approval of Compliance Certification Services Inc.(Wugu Laboratory)



Approved by:

A handwritten signature in black ink, appearing to read "Sam Chuang".

Sam Chuang
Manager

Reviewed by:

A handwritten signature in black ink, appearing to read "ED. Chiang".

ED Chiang
Engineer

Revision History

Rev.	Issue Date	Revisions	Revised By
00	May 2, 2017	Initial Issue	Angel Cheng
01	May 12, 2017	<ol style="list-style-type: none">1. Modify antenna type in page 5.2. Revise Section 2 in page 93. Revise 99% occupied BW and 20dB Bandwidth in page 13-144. Revise detector in page 17	Angel Cheng
02	May 19, 2017	<ol style="list-style-type: none">1. Revise section 4.3.4 in page 16,17.	Angel Cheng

Table of contents

1. GENERAL INFORMATION	4
1.1 EUT INFORMATION.....	4
1.2 EUT CHANNEL INFORMATION	5
1.3 ANTENNA INFORMATION	5
1.4 MEASUREMENT UNCERTAINTY.....	6
1.5 FACILITIES AND TEST LOCATION	7
1.6 INSTRUMENT CALIBRATION	7
1.7 SUPPORT AND EUT ACCESSORIES EQUIPMENT.....	8
1.8 TEST METHODOLOGY AND APPLIED STANDARDS	8
1.9 TABLE OF ACCREDITATIONS AND LISTINGS	8
2. TEST SUMMERY.....	9
3. DESCRIPTION OF TEST MODES	10
3.1 THE WORST MODE OF OPERATING CONDITION.....	10
3.2 THE WORST MODE OF MEASUREMENT	10
3.3 EUT DUTY CYCLE	11
4. TEST RESULT.....	12
4.1 AC POWER LINE CONDUCTED EMISSION	12
4.2 EMISSION BANDWIDTH.....	13
4.3 FIELD STRENGTH OF FUNDAMENTAL.....	15
4.4 RADIATION UNWANTED EMISSION.....	18
4.5 OPERATION RESTRICTION.....	26

APPENDIX 1 – PHOTOGRAPHS OF EUT

1. GENERAL INFORMATION

1.1 EUT INFORMATION

Applicant	Buddy Platform, Inc. 217 Pine Street, Suite 700 Seattle, WA 98101, USA
Equipment	Ohm Sense 100
Model Name	Ohm Sense 100
Model Discrepancy	N/A
Received Date	April 18, 2017
Date of Test	April 20 ~ 26, 2017
Maximum Output Power	1mW
Periodic operation	<input type="checkbox"/> (1) A manually operated transmitter shall employ a switch that will automatically deactivate the transmitter within not more than 5 seconds of being released. <input type="checkbox"/> (2) A transmitter activated automatically shall cease transmission within 5 seconds after activation <input type="checkbox"/> (3) Periodic transmissions at regular predetermined intervals are not permitted. <input checked="" type="checkbox"/> (4) Periodic transmissions (lower field strength): each transmission is not greater than 1 sec and the silent period between transmissions is at least 30 times the duration of the transmission but in no case less than 10 sec.
Power Operation	<input type="checkbox"/> AC <input checked="" type="checkbox"/> DC Type : <input checked="" type="checkbox"/> Battery : 3V <input type="checkbox"/> DC Power Supply <input type="checkbox"/> External DC adapter

1.2 EUT CHANNEL INFORMATION

Frequency Range	434.00 MHz
Modulation Type	GFSK
Bandwidth	118.96 KHz
Number of Channels	1 channel

Remark:

Refer as ANSI 63.10:2013 clause 5.6.1 Table 4 for test channels

Number of frequencies to be tested		
Frequency range in which device operates	Number of frequencies	Location in frequency range of operation
<input checked="" type="checkbox"/> 1 MHz or less	1	Middle
<input type="checkbox"/> 1 MHz to 10 MHz	2	1 near top and 1 near bottom
<input type="checkbox"/> More than 10 MHz	3	1 near top, 1 near middle, and 1 near bottom

1.3 ANTENNA INFORMATION

Antenna Type	Whip Antenna
Antenna Gain	2 dBi

1.4 MEASUREMENT UNCERTAINTY

PARAMETER	UNCERTAINTY
AC Powerline Conducted Emission	+/- 1.2575
Emission bandwidth, 20dB bandwidth	+/- 1.4003
RF output power, conducted	+/- 1.1372
Power density, conducted	+/- 1.4003
3M Semi Anechoic Chamber / 30M~200M	+/- 4.0138
3M Semi Anechoic Chamber / 200M~1000M	+/- 3.9483
3M Semi Anechoic Chamber / 1GHz~8GHz	+/- 2.5975
3M Semi Anechoic Chamber / 8GHz~18GHz	+/- 2.6112
3M Semi Anechoic Chamber / 18GHz~26GHz	+/- 2.7389
3M Semi Anechoic Chamber / 26GHz~40GHz	+/- 2.9683
3M Semi Anechoic Chamber / 40GHz~60GHz	+/- 1.8509
3M Semi Anechoic Chamber / 60GHz~75GHz	+/- 1.9869
3M Semi Anechoic Chamber / 75GHz~110GHz	+/- 2.9651
3M Semi Anechoic Chamber / 110GHz~170GHz	+/- 2.7807
3M Semi Anechoic Chamber / 170GHz~220GHz	+/- 3.6437
3M Semi Anechoic Chamber / 220GHz~325GHz	+/- 4.2982

Remark:

1. This uncertainty represents an expanded uncertainty expressed at approximately the 95% confidence level using a coverage factor of $k=2$
2. ISO/IEC 17025 requires that an estimate of the measurement uncertainties associated with the emissions test results be included in the report.

1.5 FACILITIES AND TEST LOCATION

All measurement facilities used to collect the measurement data are located at
No.11, Wugong 6th Rd., Wugu Dist., New Taipei City 24891, Taiwan. (R.O.C.)

Test site	Test Engineer	Remark
AC Conduction Room	N/A	Not applicable
Radiation	ED Chiang	-
RF Conducted	Eric Lee	-

Remark: The sites are constructed in conformance with the requirements of ANSI C63.7, ANSI C63.4 and CISPR Publication 22.

1.6 INSTRUMENT CALIBRATION

RF Conducted Test Site					
Equipment	Manufacturer	Model	S/N	Cal Date	Cal Due
Spectrum Analyzer	R&S	FSV 40	101073	10/5/2016	10/4/2017

3M 966 Chamber Test Site					
Equipment	Manufacturer	Model	S/N	Cal Date	Cal Due
Bilog Antenna	Sunol Sciences	JB3	A030105	07/03/2016	07/02/2017
Horn Antenna	EMCO	3117	00055165	02/20/2017	02/19/2018
Pre-Amplifier	EMCI	EMC 012635	980151	06/23/2016	06/22/2017
Pre-Amplifier	EMEC	EM330	060609	06/08/2016	06/07/2017
Spectrum Analyzer	Agilent	E4446A	US42510252	12/05/2016	12/04/2017
Antenna Tower	CCS	CC-A-1F	N/A	N.C.R	N.C.R
Controller	CCS	CC-C-1F	N/A	N.C.R	N.C.R
Turn Table	CCS	CC-T-1F	N/A	N.C.R	N.C.R
Bilog Antenna	Sunol Sciences	JB3	A030105	07/03/2016	07/02/2017

Remark: Each piece of equipment is scheduled for calibration once a year.

1.7 SUPPORT AND EUT ACCESSORIES EQUIPMENT

There are no accessories and support equipment be used during the test.

EUT Accessories Equipment					
No.	Equipment	Brand	Model	Series No.	FCC ID
	N/A				

Support Equipment					
No.	Equipment	Brand	Model	Series No.	FCC ID
	N/A				

1.8 TEST METHODOLOGY AND APPLIED STANDARDS

The test methodology, setups and results comply with all requirements in accordance with ANSI C63.10:2013, FCC 15.231 Rules.

1.9 TABLE OF ACCREDITATIONS AND LISTINGS

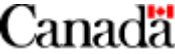
Country	Agency	Scope of Accreditation	Logo
USA	FCC	3M Semi Anechoic Chamber (FCC MRA: TW1039) to perform FCC Part 15 measurements	 FCC MRA: TW1039
Canada	Industry Canada	3M Semi Anechoic Chamber (IC 2324G-1 / IC 2324G-2) to perform	 IC 2324G-1 IC 2324G-2

** No part of this report may be used to claim or imply product endorsement by A2LA or any agency of the US Government.*

2. TEST SUMMERY

Standard Sec.	Chapter	Test Item	Result
15.203	1.3	Antenna Requirement	Pass
15.207	4.1	AC Power-line Conducted Emission	Not applicable
15.231(c)	4.2	Emission Bandwidth	Pass
15.231(e)	4.3	Fundamental Emission	Pass
15.231(e)	4.4	Transmitter Radiated Emission	Pass
15.231(a)	4.5	Operation Restriction	Pass

3. DESCRIPTION OF TEST MODES

3.1 THE WORST MODE OF OPERATING CONDITION

Operation mode	434.00 MHz
RF Filed strength	Peak: 82.59 dBuv/m Average : 42.67 dBuv/m

Remark: Field strength performed Average level at 3m.

3.2 THE WORST MODE OF MEASUREMENT

Radiated Emission Measurement Above 1GHz	
Test Condition	Band edge, Emission for Unwanted and Fundamental
DC Voltage	3V DC
Test Mode	Mode 1:EUT power by Battery.
Worst Mode	<input checked="" type="checkbox"/> Mode 1 <input type="checkbox"/> Mode 2 <input type="checkbox"/> Mode 3 <input type="checkbox"/> Mode 4
Worst Position	<input type="checkbox"/> Placed in fixed position. <input checked="" type="checkbox"/> Placed in fixed position at X-Plane (E2-Plane) <input type="checkbox"/> Placed in fixed position at Y-Plane (E1-Plane) <input type="checkbox"/> Placed in fixed position at Z-Plane (H-Plane)
Worst Polarity	<input checked="" type="checkbox"/> Horizontal <input type="checkbox"/> Vertical

Radiated Emission Measurement Below 1GHz	
Test Condition	Radiated Emission Below 1GHz
DC Voltage	3V DC
Test Mode	Mode 1:EUT power by Battery.
Worst Mode	<input checked="" type="checkbox"/> Mode 1 <input type="checkbox"/> Mode 2 <input type="checkbox"/> Mode 3 <input type="checkbox"/> Mode 4

Remark:

1. The worst mode was record in this test report.
2. EUT pre-scanned in three axis ,X, Y, Z and two polarity, Horizontal and Vertical for radiated measurement. The worst case(X-Plane and Horizontal) were recorded in this report

3.3 EUT DUTY CYCLE

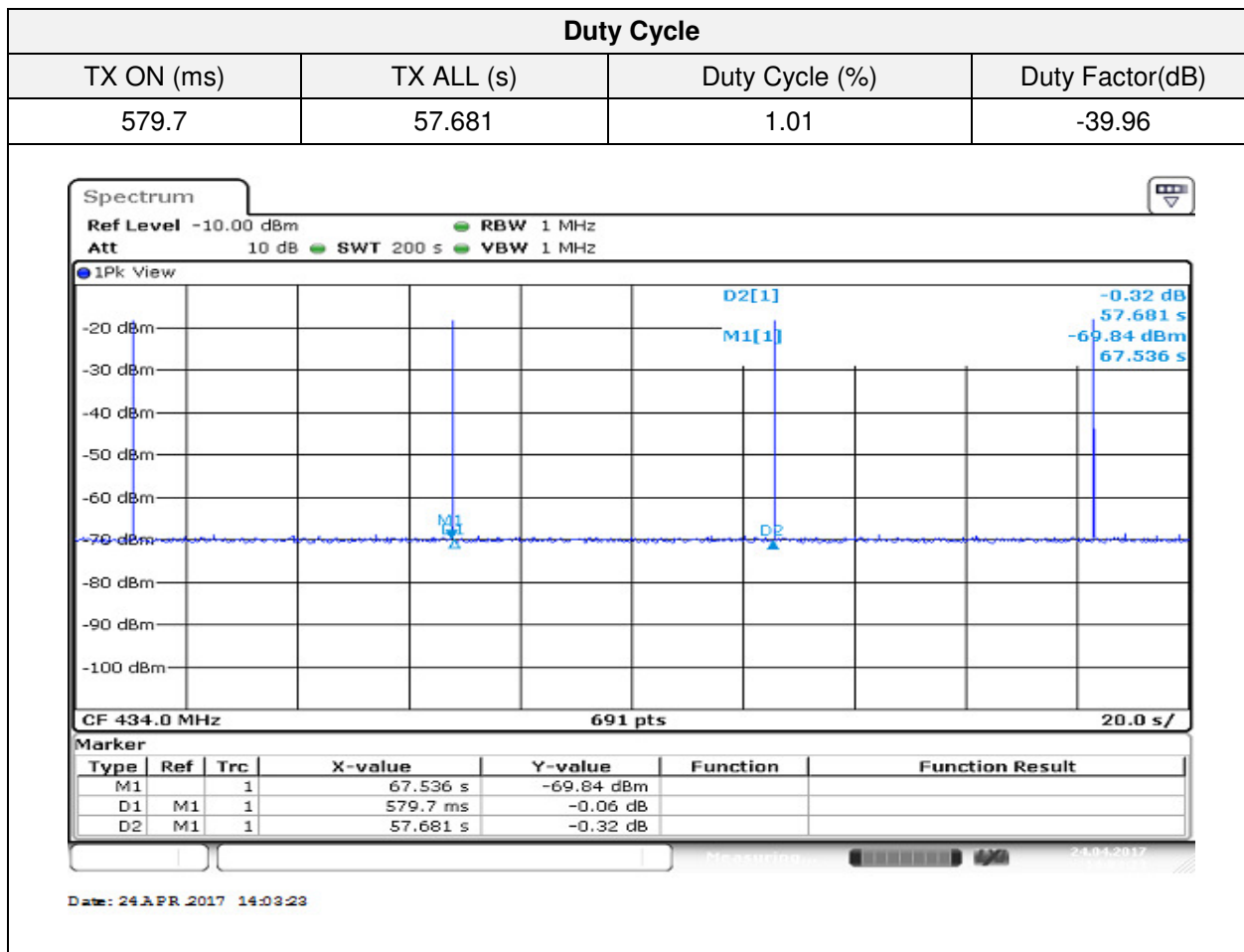

4. TEST RESULT

4.1 AC POWER LINE CONDUCTED EMISSION

4.1.1 Test Limit

According to §15.207(a) ,

Frequency Range (MHz)	Limits(dBμV)	
	Quasi-peak	Average
0.15 to 0.50	66 to 56*	56 to 46*
0.50 to 5	56	46
5 to 30	60	50

* Decreases with the logarithm of the frequency.

4.1.2 Test Procedure

Test method Refer as ANSI 63.10:2013 clause 6.2,

1. The EUT was placed on a table, which is 0.8m above ground plane.
2. Maximum procedure was performed on the six highest emissions to ensure EUT compliance.
3. Repeat above procedures until all frequency measured were complete

4.1.3 Test Setup

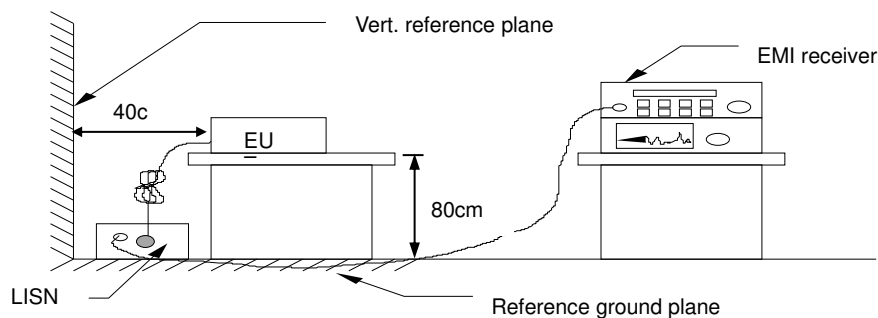

4.1.4 Test Result

Not applicable

4.2 EMISSION BANDWIDTH

4.2.1 Test Limit

According to §15.231(c) ,

Limit	<input checked="" type="checkbox"/> 70 MHz - 900 MHz : $F_c * 0.25 \%$ <input type="checkbox"/> Above 900 MHz : $F_c * 0.5 \%$
-------	---

4.2.2 Test Procedure

Test method Refer as ANSI 63.10:2013 clause 6.9.2,

The Loop antenna connected to the spectrum analyzer, was touching to the transmitter antenna. Set the RBW=10KHz, VBW ≥ 3 x RBW, Detector = Peak, Trace mode = Max hold, Sweep = Auto. Measure the maximum width of the emission that is constrained by the frequencies associated with the 20dB Bandwidth and Occupied Bandwidth(99%).

4.2.3 Test Setup

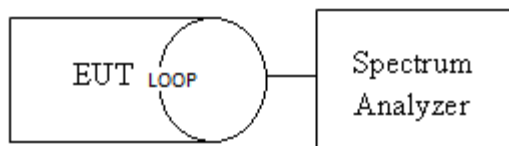

4.2.4 Test Result

Spectrum Bandwidth			
Frequency (MHz)	99% Occupied BW (KHz)	20dB Bandwidth (KHz)	20dB Bandwidth Limits (MHz)
434.00	88.1331	84.660	1.08

Test Data

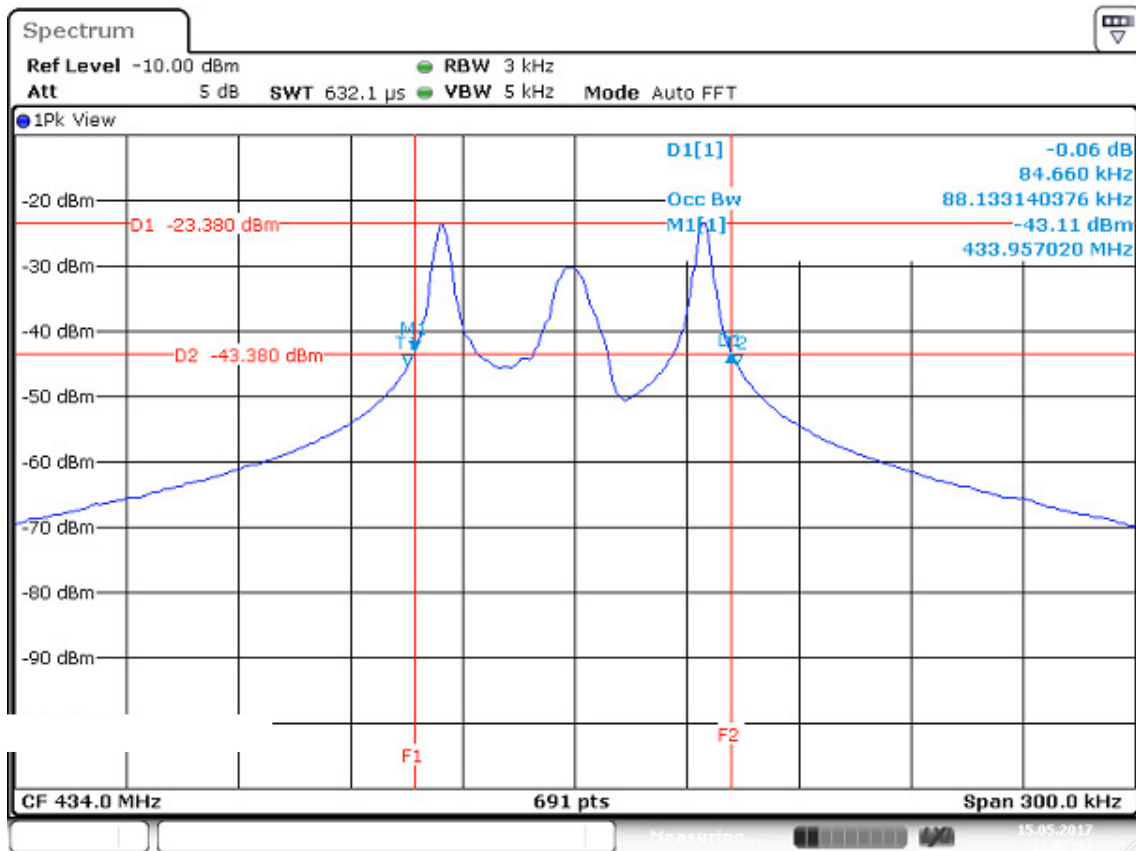

Date: 15 MAY 2017 11:07:48

4.3 FIELD STRENGTH OF FUNDAMENTAL

4.3.1 Test Limit

According to §15.231(e), For Periodic transmissions (lower field strength): each transmission is not greater than 1 sec and the silent period between transmissions is at least 30 times the duration of the transmission but in no case less than 10 sec.

Fundamental frequency (MHz)	Field strength of fundamental (microvolts/meter)	Field strength of spurious emission (microvolts/meter)
40.66-40.70	1,000	100
70-130	500	50
130-174	500 to 1,500 ¹	50 to 150 ¹
174-260	1,500	150
260-470	1,500 to 5,000 ¹	150 to 500 ¹
Above 470	5,000	500

REMARK:

1. Linear interpolations
2. Based on the average value of the measured Field strength of fundamental.

4.3.2 Test Procedure

Test method Refer as ANSI 63.10:2013 clause 4.1.4 and clause 6.5

clause 4.1.4	<input checked="" type="checkbox"/> 4.1.4.2.2: Measurement Peak value. <input type="checkbox"/> 4.1.4.2.3: Duty cycle ≥ 100%. <input checked="" type="checkbox"/> 4.1.4.2.4: Measurement Average value.
--------------	---

REMARK:

1. Duty factor = $20 \log(\text{dwell time})$
2. Average emission = Peak emission + $20 \log(\text{duty cycle})$.

4.3.3 Test Setup

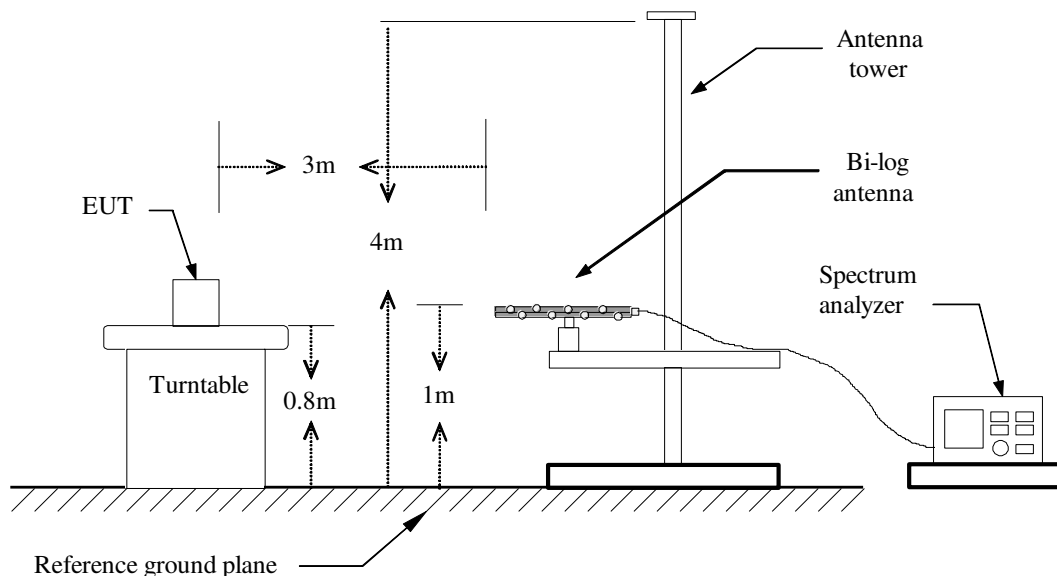

4.3.4 Test Result

Field Strength					
Frequency (MHz)	Fundamental (dBuV/m) at 3m	Limit (dBuV/m) at 3m	Margin (dB)	Axis/Pol.	Remark
434.00	42.67	72.87	-30.2	X/H	Avg

Remark

1. Average results = actual peak readings + correction factor (-39.96 dB).
2. The correction factor can be referring duty factor of section 3.3.
3. Fundamental measured method setting on spectrum, RBW=100 kHz, VBW=100kHz and Detector=Peak.

Test Data

Test Mode:	TX	Temp/Hum	27(°C)/ 53%RH
Test Item	Fundamental	Test Date	2017/04/26
Axis/Polarize	X-Plane/Hor	Test Engineer	ED Chiang.
Detector	Peak	Test Voltage:	3Vdc

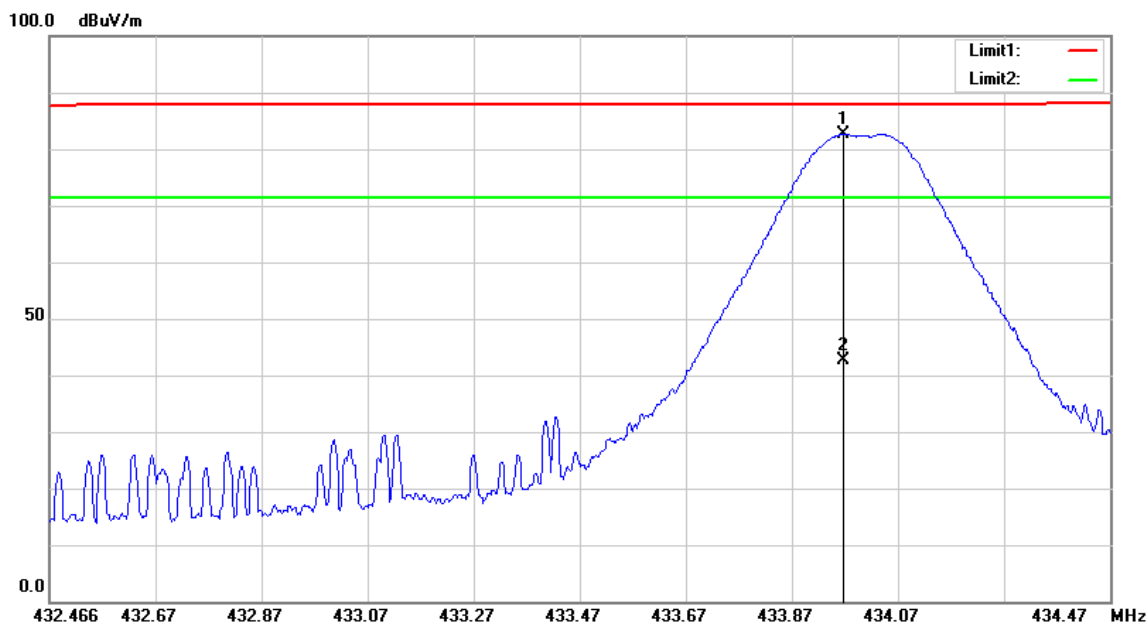

No.	Frequency (MHz)	Reading (dBuV)	Correct Factor(dB/m)	Result (dBuV/m)	Limit (dBuV/m)	Margin (dB)	Remark
1	433.9640	95.69	-13.10	82.59	92.87	-10.28	peak
2	433.9640	55.77	-13.10	42.67	72.87	-30.2	AVG

Average results = actual peak readings + correction factor (-39.96 dB).

4.4 RADIATION UNWANTED EMISSION

4.4.1 Test Limit

According to §15.231(e) and §15.209

Unwanted emissions limit follow the table or the FCC Part 15.209.

According to §15.231(e), For Periodic transmissions (lower field strength): each transmission is not greater than 1 sec and the silent period between transmissions is at least 30 times the duration of the transmission but in no case less than 10 sec.

Fundamental frequency (MHz)	Field strength of fundamental (microvolts/meter)	Field strength of spurious emission (microvolts/meter)
40.66-40.70	1,000	100
70-130	500	50
130-174	500 to 1,500 ¹	50 to 150 ¹
174-260	1,500	150
260-470	1,500 to 5,000 ¹	150 to 500 ¹
Above 470	5,000	500

REMARK:

1. Linear interpolations
2. Based on the average value of the measured Field strength of fundamental.

Below 30MHz

Frequency (MHz)	Field Strength				
	(μ V/m)	(dB μ V/m)	Measurement Distance (meter)	(dB μ V/m)	Measurement Distance (meter)
0.009 - 0.490	2400/F(kHz)	48.52 – 13.80	300	128.52–104.84	3
0.490 - 1.705	24000/F(kHz)	33.80 – 22.97	30	73.80– 62.97	3
1.705 – 30.0	30	29.54	30	69.54	3

Above 30MHz

Frequency (MHz)	Field Strength		Measurement Distance (meter)
	(μ V/m)	(dB μ V/m)	
30-88	100	40.0	3
88-216	150	43.5	3
216-960	200	46.0	3
Above 960	500	54.0	3

4.4.3 Test Setup

9kHz ~ 30MHz

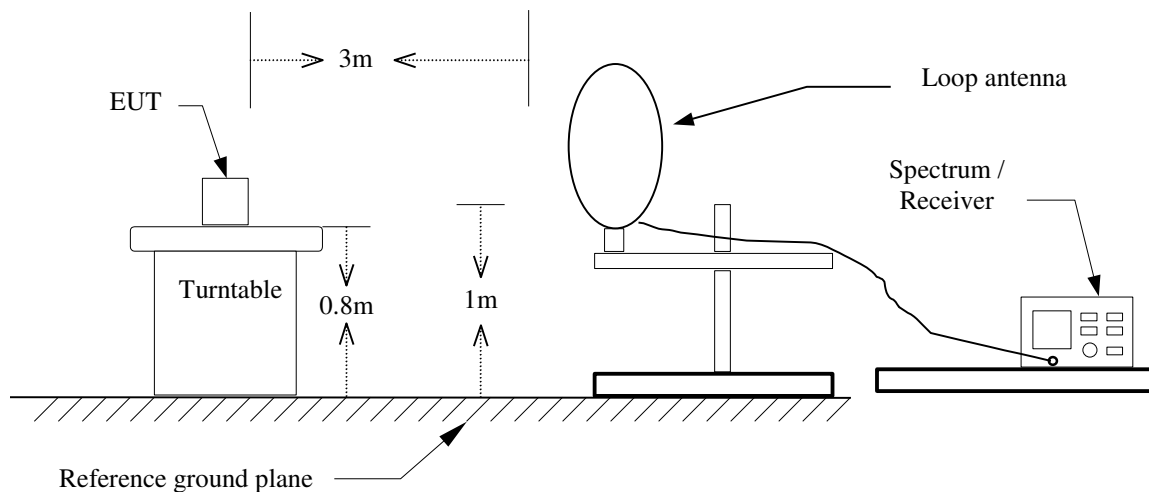

30MHz ~ 1 GHz

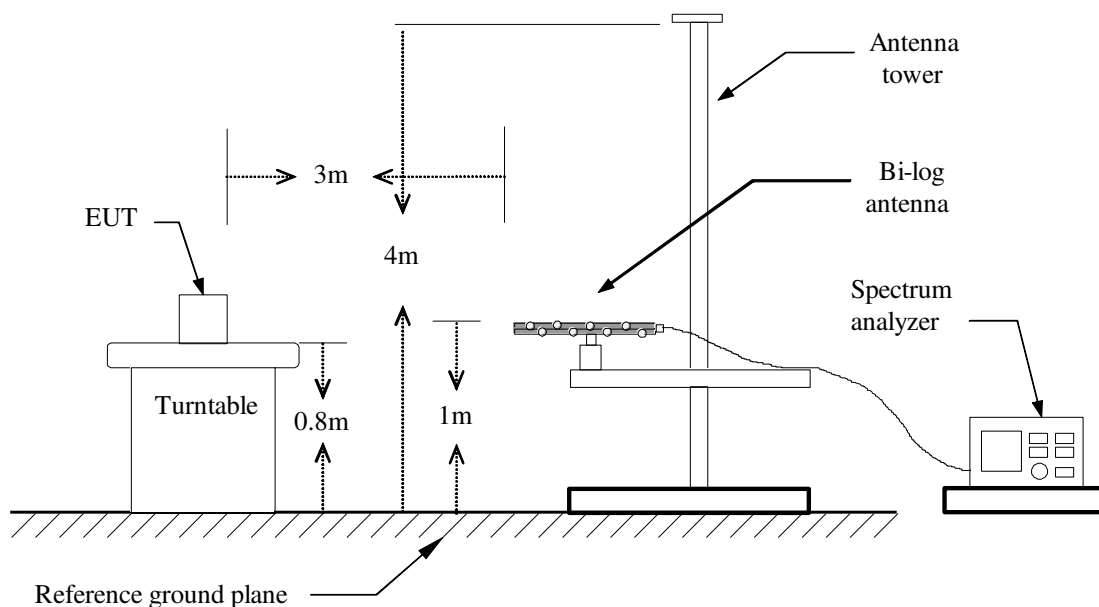

Above 1 GHz

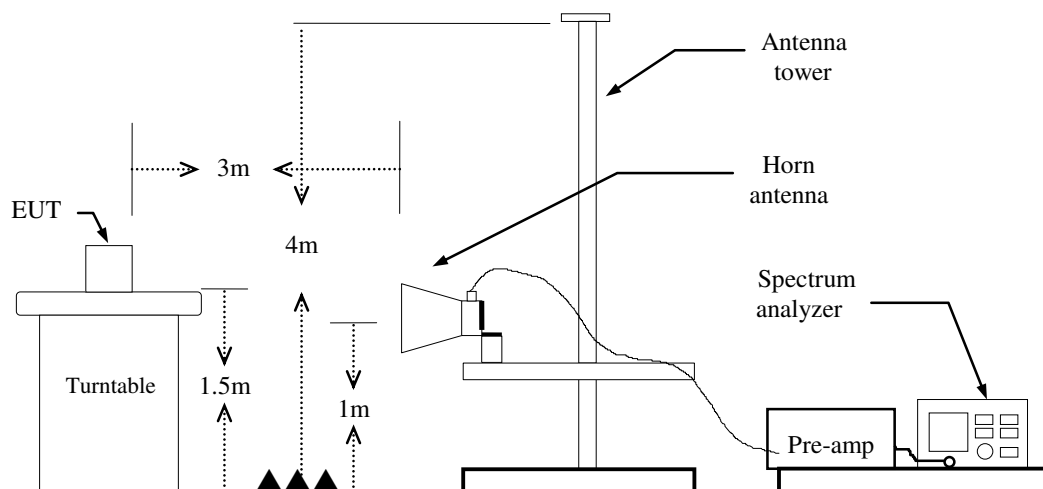

4.4.4 Test Result

Pass.

Test Data

Below 1GHz

Test Mode:	TX	Temp/Hum	27(°C)/ 53%RH
Test Item	Below 1GHz	Test Date	2017/04/20
Polarize	Vertical	Test Engineer	ED Chiang.
Detector	Peak	Test Voltage:	3Vdc

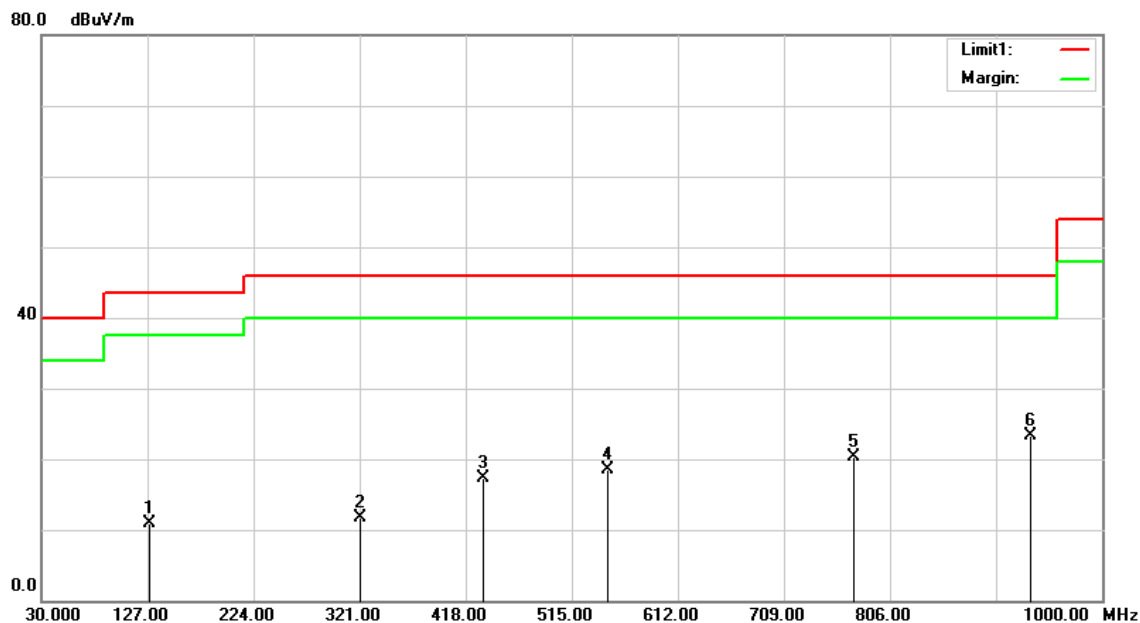

Frequency (MHz)	Reading (dBuV)	Correction Factor (dB/m)	Result (dBuV/m)	Limit (dBuV/m)	Margin (dB)	Remark
128.9400	26.58	-15.63	10.95	43.50	-32.55	peak
321.0000	25.39	-13.67	11.72	46.00	-34.28	peak
434.4900	27.94	-10.66	17.28	46.00	-28.72	peak
547.9800	26.95	-8.52	18.43	46.00	-27.57	peak
773.0200	25.00	-4.73	20.27	46.00	-25.73	peak
934.0400	25.91	-2.65	23.26	46.00	-22.74	peak

Test Mode:	TX	Temp/Hum	27(°C)/ 53%RH
Test Item	Below 1GHz	Test Date	2017/04/20
Polarize	Horizontal	Test Engineer	ED Chiang.
Detector	Peak	Test Voltage:	3Vdc

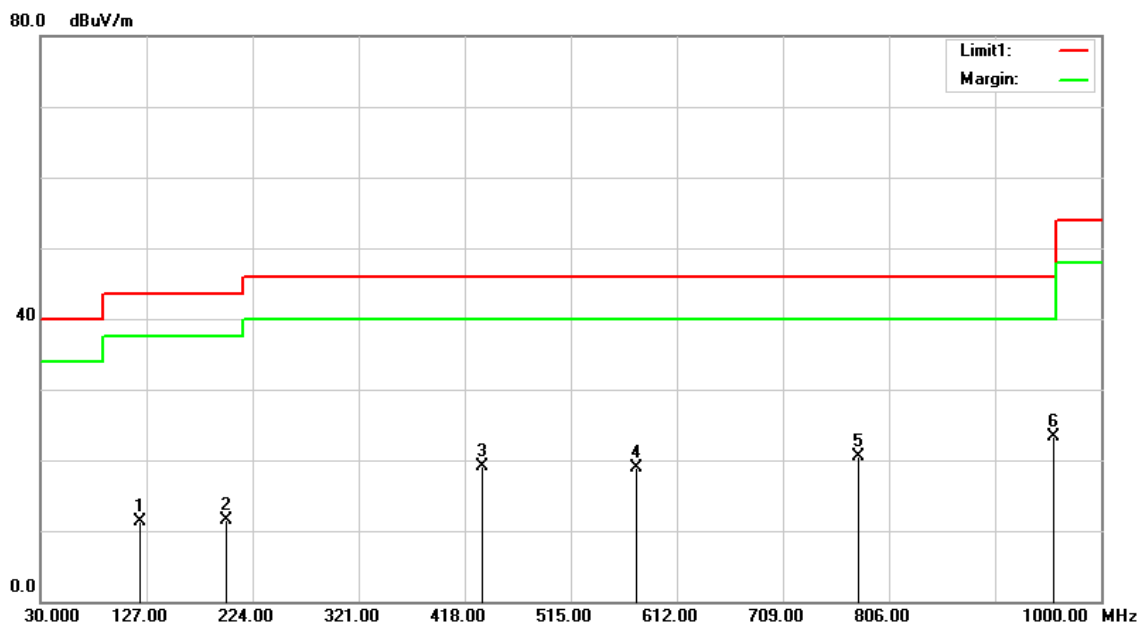

Frequency (MHz)	Reading (dBuV)	Correction Factor (dB/m)	Result (dBuV/m)	Limit (dBuV/m)	Margin (dB)	Remark
121.1800	26.77	-15.52	11.25	43.50	-32.25	peak
199.7500	27.10	-15.57	11.53	43.50	-31.97	peak
433.5200	29.87	-10.69	19.18	46.00	-26.82	peak
575.1400	27.04	-8.12	18.92	46.00	-27.08	peak
777.8700	25.17	-4.69	20.48	46.00	-25.52	peak
956.3500	25.67	-2.30	23.37	46.00	-22.63	peak

Above 1GHz

Test Mode:	TX	Temp/Hum	27(°C)/ 53%RH
Test Item	Above 1GHz	Test Date	2017/04/20
Polarize	Vertical	Test Engineer	ED Chiang.
Detector	Peak	Test Voltage:	3Vdc

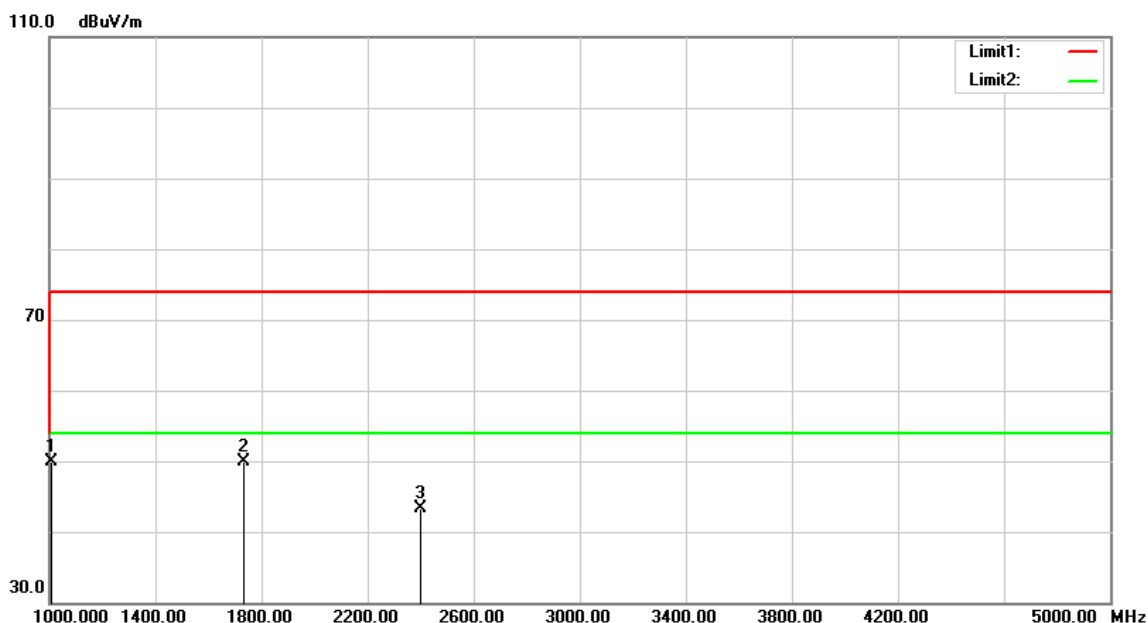

Frequency (MHz)	Reading (dBuV)	Correction Factor (dB/m)	Result (dBuV/m)	Limit (dBuV/m)	Margin (dB)	Remark
1008.000	57.84	-7.91	49.93	74.00	-24.07	peak
1732.000	54.83	-4.99	49.84	74.00	-24.16	peak
2400.000	45.74	-2.41	43.33	74.00	-30.67	peak

Remark:

1. Measuring frequencies from 1 GHz to the 10th harmonic of highest fundamental frequency.

Test Mode:	TX	Temp/Hum	27(°C)/ 53%RH
Test Item	Above 1GHz	Test Date	2017/04/20
Polarize	Horizontal	Test Engineer	ED Chiang.
Detector	Peak	Test Voltage:	3Vdc

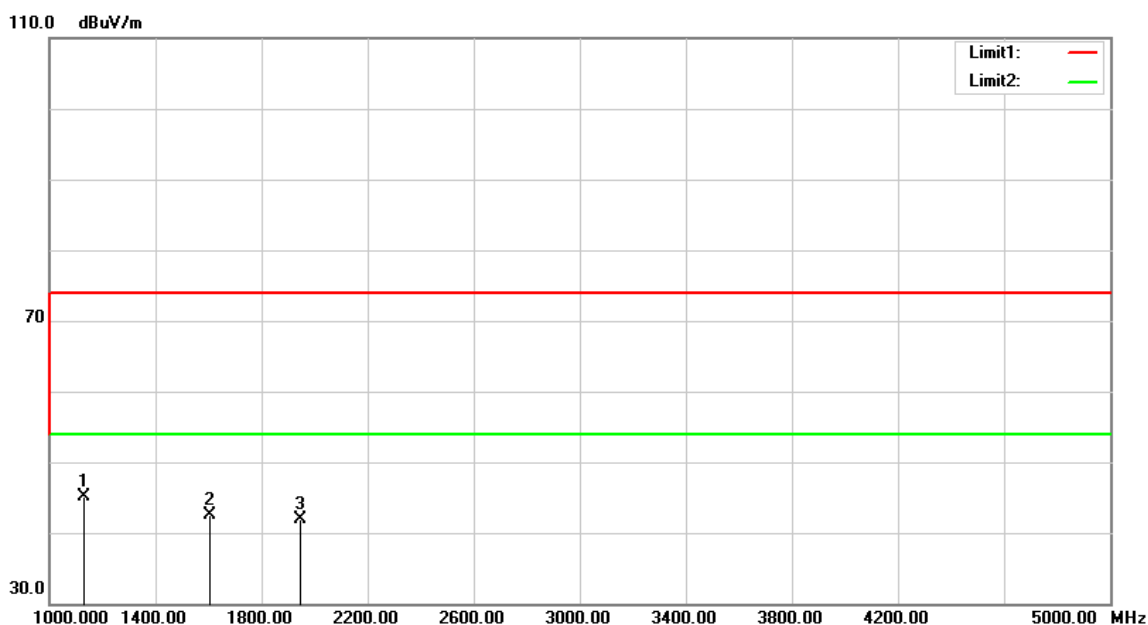

Frequency (MHz)	Reading (dBuV)	Correction Factor (dB/m)	Result (dBuV/m)	Limit (dBuV/m)	Margin (dB)	Remark
1132.000	52.54	-7.48	45.06	74.00	-28.94	peak
1604.000	48.12	-5.65	42.47	74.00	-31.53	peak
1948.000	45.78	-3.87	41.91	74.00	-32.09	peak

Remark:

1. Measuring frequencies from 1 GHz to the 10th harmonic of highest fundamental frequency.

4.5 OPERATION RESTRICTION

4.5.1 Test Limit

According to §15.231(a) (e).

Devices operated under the provisions of this paragraph shall be provided with a means for automatically limiting operation so that the duration of each transmission shall not be greater than one second and the silent period between transmissions shall be at least 30 times the duration of the transmission but in no case less than 10 seconds.

4.5.2 Test Procedure

Test method Refer as ANSI 63.10:2013 clause 7.4

The Loop antenna connected to the spectrum analyzer, was touching to the transmitter antenna. Set the RBW=1MHz, VBW ≥ 3 x RBW, Detector = Peak, Trace mode = Max hold, Sweep = 200s.Measure

4.5.3 Test Setup

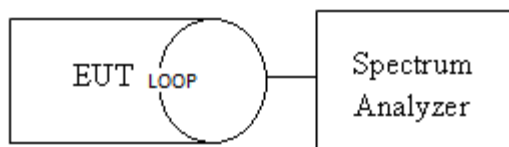

4.5.4 Test Result

Dwell Time		
Operation condition	Burst Duration	Limits
Automatically Operated	579.7 ms	1 sec

Test Data

