

Antenna specification

CUSTOMER: **Shenzhen WanLIWEI Electronics Co., LTD**

DESC: **A11 50*0.8 10UH L 45MM**

DATE: **2022/11/1**

Version: **A.0**

PREPARED BY	CHECKED BY	APPROVED BY	CUSTOMER APPROVE
Xiang Wang	Nengke Chen	Shuguang Huang	

Shenzhen HUA SHUNWEI Electronics Co., LTD

Address: 2F, Building B, Hubin Science Park, Xintian Community, Fuhai Street,
Baoan District, Shenzhen City

Tel:13682365956 contact:Mr.Lei

E - m a i l :

leizheng1987@126.com

Version Change History

Rev.	Before Change	After Change	Change Date	Approved By
------	---------------	--------------	-------------	-------------

A.0	New publish	----	2022/07/11	Shuguang Huang

SPECIFICATION

DESC	A11 50*0.8 10UH L45MM	Rev: A.0	CUST:	
			CUST P/N:	
1. DIMENSION:(mm)			A	49.5.0±0.5
			B	5.0±1.0
			C	45MM±2

2. SCHEMATIC DIAGRAM:

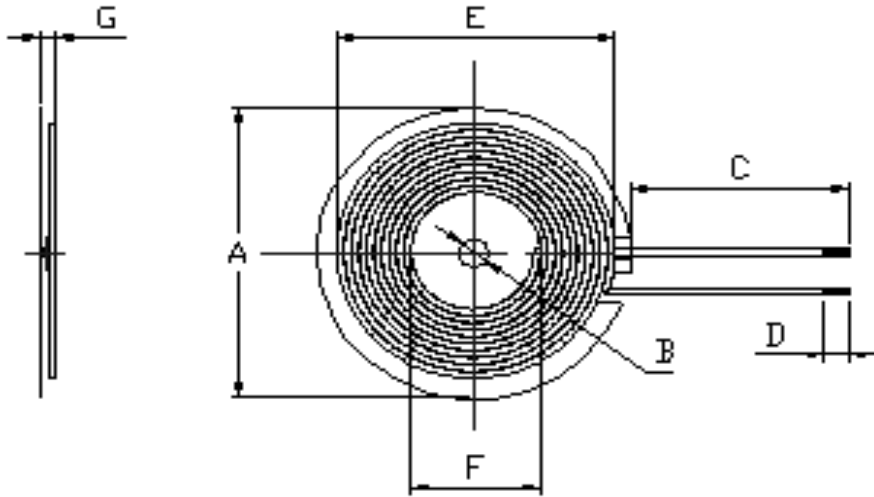

D	4.5±2
E	46.5±0.5
F	20.5±0.5
G	2.0MM±0.2

Note:

1. Cross out cables;
2. Wrap 8mm high temperature adhesive paper 1-2Ts in the outlet position (ref);
3. The coil is attached to the circular hard magnetic sheet with groove, the size of the magnetic sheet is 49.5±0.5mm, the inner hole is 5mm, and the thickness is 0.8±0.2mm.

3. Winding Specification:

NO.	TERMINAL		WIRE	Turns	Winding Direction
1	S	F	0.08*105P	12Ts	CCW

Antenna gain:0dBi

4. ELECTRICAL CHARACTERISTICS:

TEMPERATURE:25±10°C, RELATIVE HUMIDITY:65±20%

NO.	ITEM	TERMINAL	SPECIFICATION	TEST FREQUENCY	TEST EQUIPMENTS
1	IND.	S-F	4.6uH ±20% Individual coil	100KHz/1.0V	LCZ METER 1062B
2	IND.	S-F	10uH ±10%Magnetic plate	100KHz/1.0V	LCZ METER 1062B
3	DCR	S-F	≤50mΩ		LCZ METER 502B

PREPARED BY/DATE	CHECKED BY/DATE
Xiang Wang 2022/11/1	Shuguang Huang 2022/11/1