

DESC	Φ 20.5x43-6.8uH-0.08x105	Rev: A.0	客户料号CUSTP/N:
------	--------------------------	----------	--------------

一、尺寸DIMENSION:(mm)

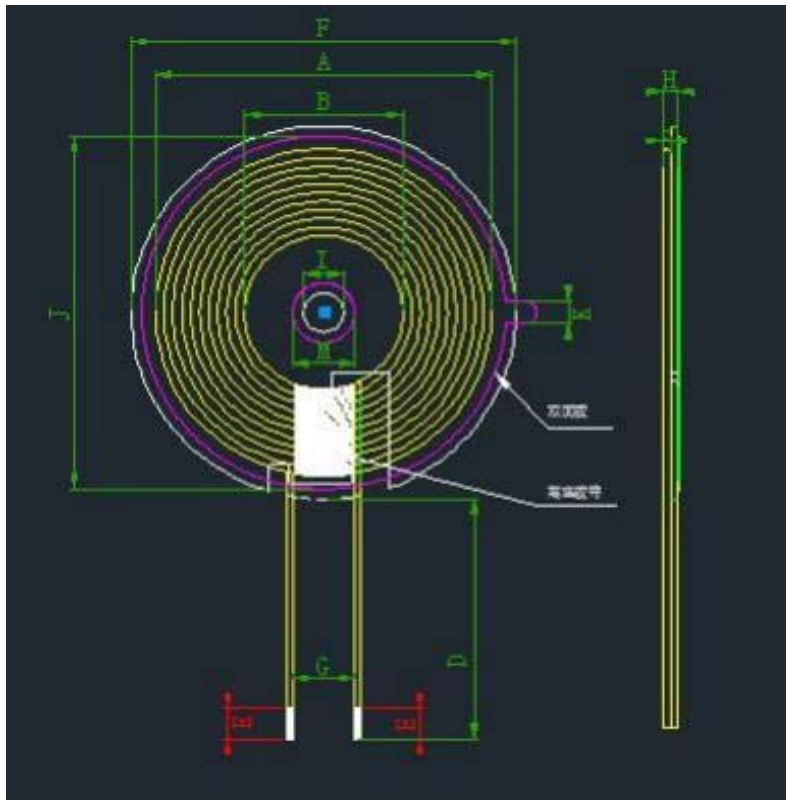

A	43.0±1.5
B	20.5±0.5
C	1.25 Max
D	50±2
E	4±2
F	50±1
G	10.0ref
H	2.2 Max
I	5.3ref
M	8.0ref
J	47±1
K	3.0±1

Remarks:

- 交叉出线Cross outgoing line;
- 出线位置缠8mm(ref)宽度高温胶纸1-2Ts; high-temperature adhesive tape 1-2Ts around the outlet position
- 线圈贴圆形硬磁片带槽, Coil mounted on circular hard magnetic disc with slot
磁片尺寸 magnetic disc Size:50±1mm,
内孔dia of inner hole: 5.3mm,
厚度Thickness: 1.0±0.2mm。

二、原理图SCHEMATIC DIAGRAM:



三、绕线参数Winding Specification:

序号 NO.	端子 TERMINAL	线径 WIRE	圈数 Turns	绕线方向 Winding Direction
1	S F	丝包线0.08*105P	10Ts	CCW

四、电气特性ELECTRICAL CHARACTERISTICS:

温度TEMPERATURE:25±10°C, 湿度RELATIVE HUMIDITY:65±20%

序号 NO.	项目 ITEM	端子 TERMINAL	标准 SPECIFICATION	测试条件 TEST FREQUENCY	测试仪器 TEST EQUIPMENTS
1	IND.	S-F	3.8uH ±20% Coil only	100KHz/1.0V	LCZMETER1062B
2	IND.	S-F	6.8uH ±10% with magnetic disc added	100KHz/1.0V	LCZMETER1062B
3	DCR	S-F	≤50mΩ		LCZMETER502B