

LED LANTERN WIRELESS SPEAKER

VIVITAR®

 Bluetooth®



Connect
Wirelessly

Built-in
Speaker

600
Lumens



Important Safety Precautions

When using your Realtree LED Lantern Wireless Speaker, basic safety precautions should always be followed, including the following:

1. READ ALL INSTRUCTIONS BEFORE USING YOUR SPEAKER.
2. Clean using a soft cloth or paper towel.
3. Do not allow children or the infirm to play with your speaker without adult supervision.
4. Do not expose your speaker to excessive heat, flames or fire.
5. Always press all buttons or switches carefully. Do not manhandle your speaker.
6. Do not use in extremely dry environments, as this can lead to static discharge during usage.
7. Do not expose your speaker to temperatures above 40°C.
8. Do not attempt to repair this product yourself. Contact a qualified service center if your speaker is in need of service.
9. Do not drop, puncture or expose your speaker to excessive trauma.
10. Your speaker is not intended for commercial use.
11. Do not place near objects that generate a strong magnetic field.
12. Unplug this device when not in use for long periods of time or during lightning storms.
13. Please recycle or dispose of your speaker properly based on the laws and rules of your municipality. Contact local recycling facilities and/or the manufacturer of your speaker for further information.



CAUTION

BATTERY WARNING:

- The device is equipped with an integrated lithium ion battery. The battery cannot be replaced.
Do not attempt to remove the battery from the device.
- Do not dispose of in fire or expose to excessive heat.
- Do not crush, puncture, incinerate, or short circuit external contacts.
- Please recycle or dispose of the battery properly. Contact your local recycling facilities and/or the manufacturer for further information.

Introduction

Thank you for purchasing the Realtree LED Lantern Wireless Speaker, item RLT6006-CM. You can use your speaker with most smartphones and Bluetooth devices to stream music wirelessly. In order to get the best results when using this device, please read this manual first before using.

Package Contents

- RLT6006-CM Realtree LED Lantern Wireless Speaker
- USB Charging Cable
- User's Manual with Warranty Information

Specifications

Bluetooth Version: JL5.1

Bluetooth Range: Approximately 10 meters

Battery; 3.7V 1200mAh rechargeable lithium-ion

Charge Time: Approximately 3 hours

Speaker Power: 3W

Input : DC 5V

Weight: 407g

Product Size: 96 x 96 x 183mm

Working Time in Different Mode:

Yellow Light Only = Up to 10 hours

White Light Only = Up to 6 Hours

Music Only = Up to 12 Hours

White Light + Music = Up to 8 hours

Yellow Light + Music = Up to 9 Hours

*Applicable at 50% of maximum volume. Results will be lower when volume is higher.

A Quick Look at Your Device

Front View

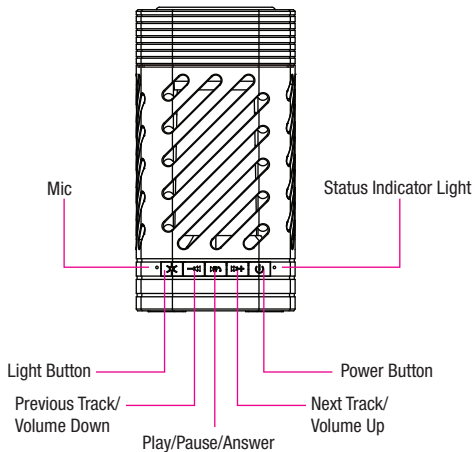

Rear View

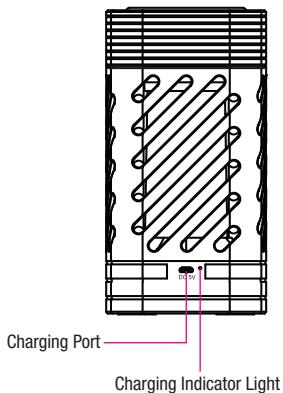

Charging Your Speaker

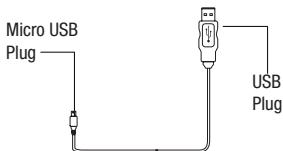

1. The USB charging cable has a Micro USB plug and a standard USB plug.

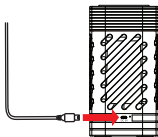

2. Insert the USB charging cable's Micro USB plug into the Charging Port on the back of your speaker.

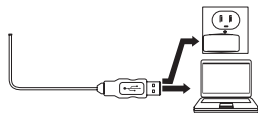

3. Insert the USB charging cable's standard USB plug into the USB port of a computer or suitable USB charging adapter.

4. The Charging Indicator Light turns red while the speaker is charging. And turns off when it is fully charged.

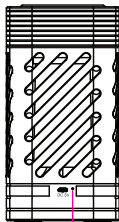

CHARGING INDICATOR LIGHT

- (red) = Charging
- (off) = Charged

NOTES:

--Charging can take approximately 3 hours to complete when the battery is fully drained.

--Remove the charging cable once charging is complete.

--Overcharging could reduce the life of the battery.

--A charged battery will lose its capacity if it is not used on a regular basis.

Important: To avoid a complete discharge of the battery, charge your speaker at least once every six months.

Bluetooth Pairing

Power Button

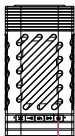

1. Press and hold the Power Button to turn on your speaker.

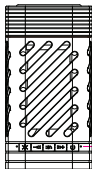

Pairing Mode
Blue Flashing



2. The Status Indicator Light will turn blue and flash rapidly to indicate that your speaker is in pairing mode.



3. Go to the Bluetooth settings menu on your phone. Make sure that Bluetooth is turned on. Connect to the device listed as "RLT6006."

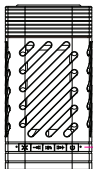

Paired
Blue



4. The Status Indicator Light will stop flashing and remain blue to indicate that your speaker is paired with your phone. Note that the light may flash slowly while music is playing.

TWS Pairing

You can use the TWS feature to pair two of the same model speakers together. To do so, follow the steps below.

1. Turn on both speakers by press and hold their Power Buttons.
2. Press one of the speaker's Play/Pause Button once to let them pair each other.
3. Go to the Bluetooth settings menu on your phone. Make sure that Bluetooth is turned on. Connect to the device listed as "RLT6006."

NOTE:

--If the two speakers have been previously paired together, they will pair together automatically when powered on.

--Press and hold the Power button on a speaker to unpair it with the other speaker.

Using Your Wireless Speaker

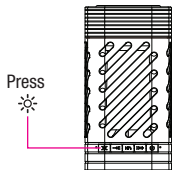

1. Press the Light button repeatedly to turn the lantern's light on or off.

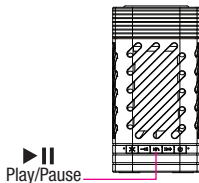

2. Press the Play/Pause button to play a track. Press it again to pause a track.

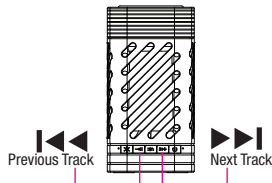

3. Press the Next Track, or Previous Track buttons to skip ahead to the next track or return to the previous track.

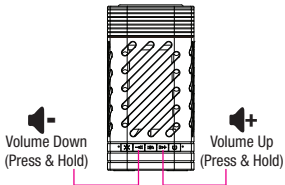

4. Press and hold the + Button to increase the volume. Press and hold the - Button to decrease the volume.

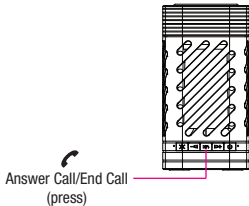

5. Press the Answer button to answer an incoming call or end a call.

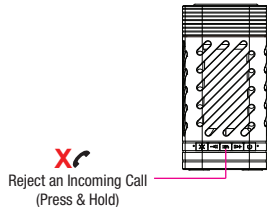

6. Press and hold the Answer button to reject an incoming call.

FCC Statement

Changes or modifications not expressly approved by the party responsible for compliance could void the user's authority to operate the equipment.

This device complies with Part 15 of the FCC Rules. Operation is subject to the following two conditions: (1) this device may not cause harmful interference, and (2) this device must accept any interference received, including interference that may cause undesired operation.

This equipment has been tested and found to comply with the limits for a Class B digital device, pursuant to Part 15 of the FCC Rules. These limits are designed to provide reasonable protection against harmful interference in a residential installation. This equipment generates, uses and can radiate radio frequency energy and, if not installed and used in accordance with the instructions, may cause harmful interference to radio communications. However, there is no guarantee that interference will not occur in a particular installation. If this equipment does cause harmful interference to radio or television reception, which can be determined by turning the equipment off and on, the user is encouraged to try to correct the interference by one or more of the following measures:

- Reorient or relocate the receiving antenna.
- Increase the separation between the equipment and receiver.
- Connect the equipment into an outlet on a circuit different from that to which the receiver is connected.
- Consult the dealer or an experienced radio/TV technician for help.

Vivitar One Year Warranty (continued)

This warranty covers the original consumer purchaser only and is not transferable. This warranty covers products that fail to function properly UNDER NORMAL USAGE, due to defects in material or workmanship. Your product will be repaired or replaced at no charge for parts or labor for a period of one year.

What Is Not Covered by Warranty

Damages or malfunctions not resulting from defects in material or workmanship and damages or malfunctions from other than normal use, including but limited to, repair by unauthorized parties, tampering, modification or accident.

To Obtain Warranty Service and Troubleshooting Information:

Call 1-800-592-9541 or visit our website at www.vivitar.com.

To receive warranty service along with the name and address of an authorized product service center, the original consumer purchaser must contact us for problem determination and service procedures. Proof of purchase in the form of a bill of sale or receipted invoice, evidencing that the product is within the applicable warranty period(s), MUST be presented in order to obtain the requested service. It is your responsibility to properly package and send any defective products along with a dated copy of proof of purchase, a written explanation of the problem, and a valid return address to the authorized service center at your expense. Do not include any other items or accessories with the defective product. Any products received by the authorized service center that are not covered by warranty will be returned unrepaid.

NO WARRANTIES, WHETHER EXPRESS OR IMPLIED, INCLUDING, BUT NOT LIMITED TO, ANY IMPLIED WARRANTIES OF MERCHANTABILITY OR FITNESS FOR A PARTICULAR PURPOSE, OTHER THAN THOSE EXPRESSLY DESCRIBED ABOVE SHALL APPLY. DISTRIBUTOR FURTHER DISCLAIMS ALL WARRANTIES AFTER THE EXPRESS WARRANTY PERIOD STATED ABOVE. NO OTHER EXPRESS WARRANTY OR GUARANTY GIVEN BY ANY PERSON, FIRM OR ENTITY WITH RESPECT TO THE PRODUCT SHALL BE BINDING ON DISTRIBUTOR. REPAIR, REPLACEMENT, OR REFUND OF THE ORIGINAL PURCHASE PRICE - AT DISTRIBUTOR'S SOLE DISCRETION - ARE THE EXCLUSIVE REMEDIES OF THE CONSUMER. IN NO EVENT WILL DISTRIBUTOR, ITS MANUFACTURERS, OR SAKAR INT. BE LIABLE FOR ANY INCIDENTAL, DIRECT, INDIRECT, SPECIAL, PUNITIVE OR CONSEQUENTIAL DAMAGES (SUCH AS, BUT NOT LIMITED TO, DAMAGES FOR LOSS OF PROFITS, BUSINESS, SAVINGS, DATA OR RECORDS) CAUSED BY THE USE, MISUSE OR INABILITY TO USE THE PRODUCT. EXCEPT AS STATED HEREIN, NO OTHER WARRANTIES SHALL APPLY. NOTWITHSTANDING THE FOREGOING, CONSUMER'S RECOVERY AGAINST DISTRIBUTOR SHALL NOT EXCEED THE PURCHASE PRICE OF THE PRODUCT SOLD BY DISTRIBUTOR. THIS WARRANTY SHALL NOT EXTEND TO ANYONE OTHER THAN THE ORIGINAL CONSUMER WHO PURCHASED THE PRODUCT AND IS NOT TRANSFERABLE.

Some countries, states or provinces do not allow the exclusion or limitation of incidental or consequential damages or allow limitations on warranties, so limitation or exclusions may not apply to you. This warranty gives you specific legal rights, and you may have other rights that vary from state to state or province to province. Contact your authorized retailer to determine if another warranty applies.

The Bluetooth® word mark and logos are registered trademarks owned by the Bluetooth SIG, Inc. and any use of such marks by Sakar International is under license. Other trademarks and trade names are those of their respective owners.